

General Description

The 8343-01 is a low skew, 1-to-16 LVCMOS/LVTTTL Fanout Buffer. The 8343-01 single ended clock input accepts LVCMOS or LVTTTL input levels. The ICS8343-01 operates at 3.3V, 2.5V and mixed 3.3V input and 2.5V supply modes over the commercial temperature range. Guaranteed output and part-to-part skew characteristics make the 8343-01 ideal for those clock distribution applications demanding well defined performance and repeatability.

Features

- 16 LVCMOS/LVTTTL outputs
- One LVCMOS/LVTTTL clock input
- CLK can accept the following input levels: LVCMOS, LVTTTL
- Maximum output frequency: 200MHz
- Dual output enable inputs facilitates 1-to-16 or 1-to-8 input to output modes
- All inputs are 5V tolerant
- Output skew: 250ps (maximum)
- Part-to-part skew: 700ps (maximum)
- Full 3.3V and 2.5V or mixed 3.3V core/2.5V operating supply
- 0°C to 70°C ambient operating temperature
- Lead-Free packaging
- Industrial temperature information available upon request

Block Diagram

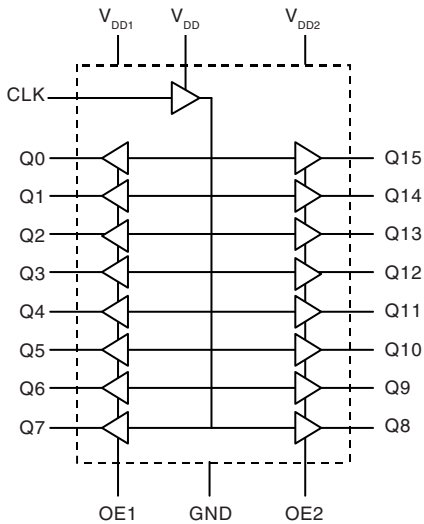

Pin Assignment

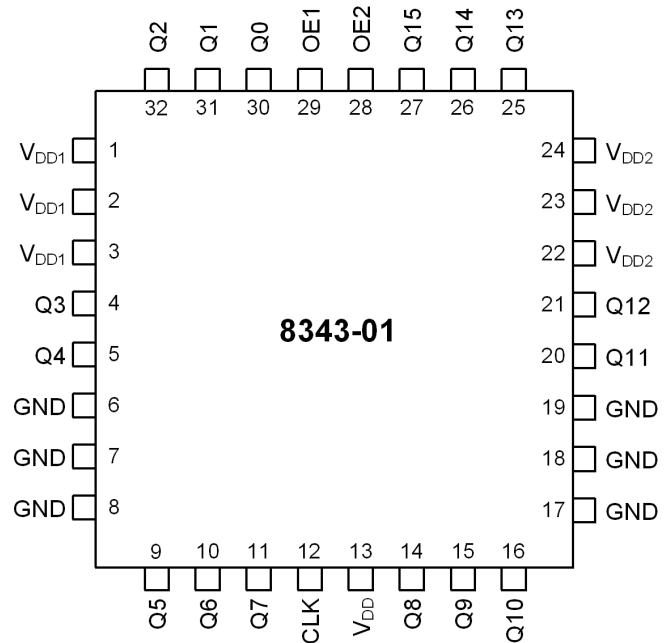

32-Lead LQFP
7mm x 7mm x 1.4mm body package
Y Package
 (Top View)

Pin Descriptions and Characteristics

Table 1. Pin Descriptions¹

Number	Name	Type		Description
1	V _{DD1}	Power		Q0 through Q7 output supply pin.
2	V _{DD1}	Power		Q0 through Q7 output supply pin.
3	V _{DD1}	Power		Q0 through Q7 output supply pin.
4	Q3	Output		LVC MOS/LVTTL clock output. 7Ω typical output impedance.
5	Q4	Output		LVC MOS/LVTTL clock output. 7Ω typical output impedance.
6	GND	Power		Power supply ground.
7	GND	Power		Power supply ground.
8	GND	Power		Power supply ground.
9	Q5	Output		LVC MOS/LVTTL clock output. 7Ω typical output impedance.
10	Q6	Output		LVC MOS/LVTTL clock output. 7Ω typical output impedance.
11	Q7	Output		LVC MOS/LVTTL clock output. 7Ω typical output impedance.
12	CLK	Input	Pulldown	LVC MOS/LVTTL clock input / 5V tolerant.
13	V _{DD}	Power		Core supply pin.
14	Q8	Output		LVC MOS/LVTTL clock output. 7Ω typical output impedance.
15	Q9	Output		LVC MOS/LVTTL clock output. 7Ω typical output impedance.
16	Q10	Output		LVC MOS/LVTTL clock output. 7Ω typical output impedance.
17	GND	Power		Power supply ground.
18	GND	Power		Power supply ground.
19	GND	Power		Power supply ground.
20	Q11	Output		LVC MOS/LVTTL clock output. 7Ω typical output impedance.
21	Q12	Output		LVC MOS/LVTTL clock output. 7Ω typical output impedance.
22	V _{DD2}	Power		Q8 through Q15 output supply pin.
23	V _{DD2}	Power		Q8 through Q15 output supply pin.
24	V _{DD2}	Power		Q8 through Q15 output supply pin.
25	Q13	Output		LVC MOS/LVTTL clock output. 7Ω typical output impedance.
26	Q14	Output		LVC MOS/LVTTL clock output. 7Ω typical output impedance.
27	Q15	Output		LVC MOS/LVTTL clock output. 7Ω typical output impedance.
28	OE2	Input	Pullup	Output enable. When low forces outputs Q8 through Q15 to HiZ state. 5V tolerant. LVC MOS/LVTTL interface levels.
29	OE1	Input	Pullup	Output enable. When low forces outputs Q0 through Q7 to HiZ state. 5V tolerant. LVC MOS/LVTTL interface levels.
30	Q0	Output		LVC MOS/LVTTL clock output. 7Ω typical output impedance.
31	Q1	Output		LVC MOS/LVTTL clock output. 7Ω typical output impedance.
32	Q2	Output		LVC MOS/LVTTL clock output. 7Ω typical output impedance.

NOTE 1: *Pullup* and *Pulldown* refer to internal input resistors. See Table 2, *Pin characteristics*, for typical values.

Table 2. Pin Characteristics

Symbol	Parameter	Test Conditions	Minimum	Typical	Maximum	Units
C_{IN}	Input Capacitance			4		pF
C_{PD}	Power Dissipation Capacitance (per output)	$V_{DD}, V_{DD1}, V_{DD2} = 3.465V$		11		pF
		$V_{DD1}, V_{DD2} = 2.63V$		9		pF
R_{PULLUP}	Input Pullup Resistor			51		k Ω
$R_{PULLDOWN}$	Input Pulldown Resistor			51		k Ω
R_{OUT}	Output Impedance	$V_{DD}, V_{DD1}, V_{DD2} = 3.3V$	5	7	12	Ω

Table 3. Function Table¹

Inputs		Outputs	
OE1	OE2	Q0:Q7	Q8:Q15
0	0	HiZ	HiZ
1	0	Active	HiZ
0	1	HiZ	Active
1	1	Active	Active

NOTE 1: OE1 and OE2 are 5V tolerant.

Absolute Maximum Ratings

NOTE: Stresses beyond those listed under *Absolute Maximum Ratings* may cause permanent damage to the device. These ratings are stress specifications only. Functional operation of product at these conditions or any conditions beyond those listed in the *Section , "DC Electrical Characteristics" or AC Electrical Characteristics* is not implied. Exposure to absolute maximum rating conditions for extended periods may affect product reliability.

Item	Rating
Supply Voltage, V_{DD}	4.6V
Inputs, V_I	-0.5V to $V_{DD} + 0.5V$
Outputs, V_O	-0.5V to $V_{DDx} + 0.5V$
Storage Temperature, T_{STG}	-65°C to 150°C
Maximum Junction Temperature, T_{JMAX}	125°C

DC Electrical Characteristics

Table 4A. Power Supply DC Characteristics, $V_{DD} = 3.3V \pm 5\%$, $V_{DD1} = V_{DD2} = 3.3V \pm 5\%$ or $2.5V \pm 5\%$, $T_A = 0^\circ C$ to $70^\circ C$

Symbol	Parameter	Test Conditions	Minimum	Typical	Maximum	Units
V_{DD}	Core Supply Voltage		3.135	3.3	3.465	V
V_{DDx}	Output Supply Voltage ¹		3.135	3.3	3.465	V
			2.375	2.5	2.625	V
I_{DD}	Power Supply Current				35	mA
I_{DDx}	Output Supply Current ²				14	mA

NOTE 1: V_{DDx} denotes V_{DD1} and V_{DD2} .

NOTE 2: I_{DDx} denotes the sum of I_{DD1} and I_{DD2} .

Table 4B. Power Supply DC Characteristics, $V_{DD} = V_{DD1} = V_{DD2} = 2.5V \pm 5\%$, $T_A = 0^\circ C$ to $70^\circ C$

Symbol	Parameter	Test Conditions	Minimum	Typical	Maximum	Units
V_{DD}	Core Supply Voltage		2.375	2.5	2.625	V
V_{DDx}	Output Supply Voltage ¹		2.375	2.5	2.625	V
I_{DD}	Power Supply Current				34	mA
I_{DDx}	Output Supply Current ²				13	mA

NOTE 1: V_{DDx} denotes V_{DD1} and V_{DD2} .

NOTE 2: I_{DDx} denotes the sum of I_{DD1} and I_{DD2} .

Table 4C. LVCMOS / LVTTTL DC Characteristics, $V_{DD} = V_{DD1} = V_{DD2} = 3.3V \pm 5\%$ or $2.5V \pm 5\%$, $V_{DD} = 3.3V \pm 5\%$, $V_{DD1} = V_{DD2} = 2.5V \pm 5\%$, $T_A = 0^\circ C$ to $70^\circ C$

Symbol	Parameter	Test Conditions	Minimum	Typical	Maximum	Units
V_{IH}	Input High Voltage	OE1, OE2	2		$V_{DD} + 0.3$	V
		CLK	2		$V_{DD} + 0.3$	V
V_{IL}	Input Low Voltage	OE1, OE2	-0.3		0.8	V
		CLK	-0.3		1.3	V
I_{IH}	Input High Current	OE1, OE2	$V_{DD} = V_{IN} = 3.465V$ or $2.625V$		5	μA
		CLK	$V_{DD} = V_{IN} = 3.465V$ or $2.625V$		150	μA
I_{IL}	Input Low Current	OE1, OE2	$V_{DD} = 3.465V$ or $2.625V$, $V_{IN} = 0V$	-150		μA
		CLK	$V_{DD} = 3.465V$ or $2.625V$, $V_{IN} = 0V$	-5		μA
V_{OH}	Output High Voltage ¹	$V_{DD1} = V_{DD2} = 3.465V$	2.6			V
		$V_{DD1} = V_{DD2} = 2.625V$	1.8			V
V_{OL}	Output Low Voltage	$V_{DD1} = V_{DD2} = 3.465V$ or $2.625V$			0.5	V
I_{OZL}	Output Tristate Current Low				5	μA
I_{OZH}	Output Tristate Current High				5	μA

NOTE 1: Outputs terminated with 50Ω to $V_{DDx}/2$. See Parameter Measurement Information, "Output Load Test Circuit Diagrams".

AC Electrical Characteristics

Table 5A. AC Electrical Characteristics, $V_{DD} = V_{DD1} = V_{DD2} = 3.3V \pm 5\%$, $T_A = 0^\circ C$ to $70^\circ C$ ¹

Symbol	Parameter	Test Conditions	Minimum	Typical	Maximum	Units
f_{MAX}	Output Frequency				200	MHz
t_{pLH}	Propagation Delay ²	$f \leq 200MHz$	2.0		4.0	ns
$t_{sk(o)}$	Output Skew ^{3, 4}	Measured on rising edge @ $V_{DDx}/2$			250	ps
$t_{sk(pp)}$	Part-to-Part Skew ^{4, 5}	Measured on rising edge @ $V_{DDx}/2$			700	ps
t_R / t_F	Output Rise/ Fall Time	20% to 80%	0.4		1.5	ns
odc	Output Duty Cycle	$f \leq 133MHz$	45		55	%
t_{PW}	Output Pulse Width	$f > 133MHz$	$t_{PERIOD}/2 - 0.25$	$t_{PERIOD}/2$	$t_{PERIOD}/2 + 0.25$	ns

NOTE 1: All parameters measured at f_{MAX} unless noted otherwise.

NOTE 2: Measured from $V_{DD}/2$ of the input to $V_{DDx}/2$ of the output.

NOTE 3: Defined as skew between outputs at the same supply voltage and with equal load conditions. Measured at $V_{DDx}/2$.

NOTE 4: This parameter is defined in accordance with JEDEC Standard 65.

NOTE 5: Defined as skew between outputs on different devices operating at the same supply voltages and with equal load conditions. Using the same type of inputs on each device, the outputs are measured at $V_{DDx}/2$.

Table 5B. AC Electrical Characteristics, $V_{DD} 3.3V \pm 5\%$, $V_{DD1} = V_{DD2} = 2.5V \pm 5\%$, $T_A = 0^\circ C$ to $70^\circ C$ ¹

Symbol	Parameter	Test Conditions	Minimum	Typical	Maximum	Units
f_{MAX}	Output Frequency				200	MHz
t_{pLH}	Propagation Delay ²	$f \leq 200MHz$	2.0		4.5	ns
$t_{sk(o)}$	Output Skew ^{3, 4}	Measured on rising edge @ $V_{DDx}/2$			250	ps
$t_{sk(pp)}$	Part-to-Part Skew ^{4, 5}	Measured on rising edge @ $V_{DDx}/2$			700	ps
t_R / t_F	Output Rise/ Fall Time	20% to 80%	0.4		1.0	ns
odc	Output Duty Cycle	$f \leq 133MHz$	40		60	%

NOTE 1: All parameters measured at f_{MAX} unless noted otherwise.

NOTE 2: Measured from $V_{DD}/2$ of the input to $V_{DDx}/2$ of the output.

NOTE 3: Defined as skew between outputs at the same supply voltage and with equal load conditions. Measured at $V_{DDx}/2$.

NOTE 4: This parameter is defined in accordance with JEDEC Standard 65.

NOTE 5: Defined as skew between outputs on different devices operating at the same supply voltages and with equal load conditions. Using the same type of inputs on each device, the outputs are measured at $V_{DDx}/2$.

Table 5C. AC Electrical Characteristics, $V_{DD} = V_{DD2} = 3.3V \pm 5\%$, $V_{DD1} = 2.5V \pm 5\%$, $T_A = 0^\circ C$ to $70^\circ C$ ¹

Symbol	Parameter	Test Conditions	Minimum	Typical	Maximum	Units
f_{MAX}	Output Frequency				200	MHz
$t_{sk(o)}$	Output Skew ²	Measured on rising edge @ $V_{DDx}/2$			250	ps

NOTE 1: All parameters measured at f_{MAX} unless noted otherwise.

NOTE 2: Defined as skew across outputs at the same supply voltages within a bank, and with equal load conditions.

Table 5D. AC Electrical Characteristics, $V_{DD} 3.3V \pm 5\%$, $V_{DD1} = V_{DD2} = 2.5V \pm 5\%$, $T_A = 0^\circ C$ to $70^\circ C$ ¹

Symbol	Parameter	Test Conditions	Minimum	Typical	Maximum	Units
f_{MAX}	Output Frequency				133	MHz
t_{pLH}	Propagation Delay ²	$f \leq 200MHz$	2.0		4.0	ns
$t_{sk(o)}$	Output Skew ^{3, 4}	Measured on rising edge @ $V_{DDx}/2$			250	ps
$t_{sk(pp)}$	Part-to-Part Skew ^{4, 5}	Measured on rising edge @ $V_{DDx}/2$			1	ns
t_R / t_F	Output Rise/ Fall Time	20% to 80%	0.4		1.0	ns
odc	Output Duty Cycle	$f \leq 133MHz$	40		60	%

NOTE 1: All parameters measured at f_{MAX} unless noted otherwise.

NOTE 2: Measured from $V_{DD}/2$ of the input to $V_{DDx}/2$ of the output.

NOTE 3: Defined as skew between outputs at the same supply voltage and with equal load conditions. Measured at $V_{DDx}/2$.

NOTE 4: This parameter is defined in accordance with JEDEC Standard 65.

NOTE 5: Defined as skew between outputs on different devices operating at the same supply voltages and with equal load conditions. Using the same type of inputs on each device, the outputs are measured at $V_{DDx}/2$.

Parameter Measurement Information

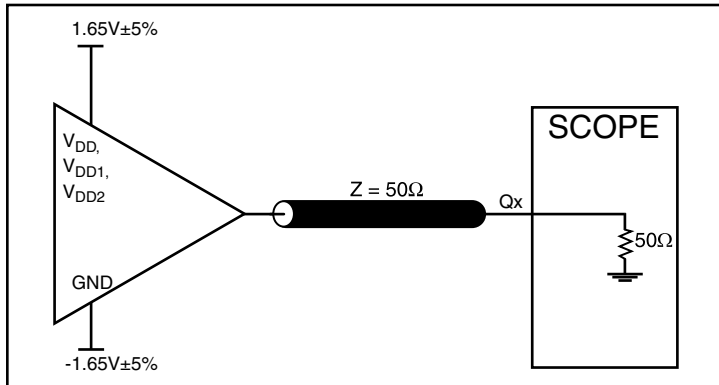

3.3V Core/3.3V Output Load Test Circuit

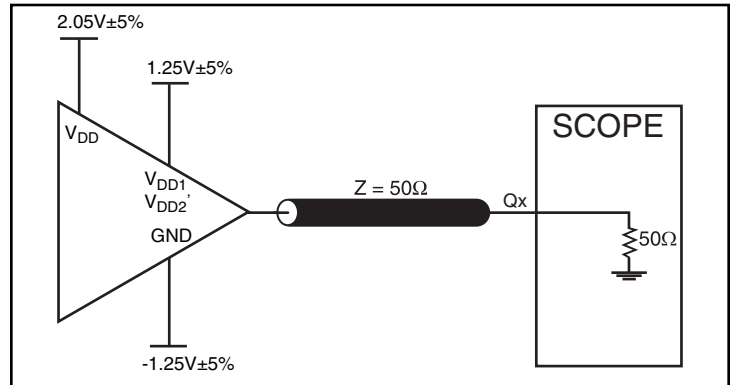

3.3V Core/2.5V Output Load Test Circuit

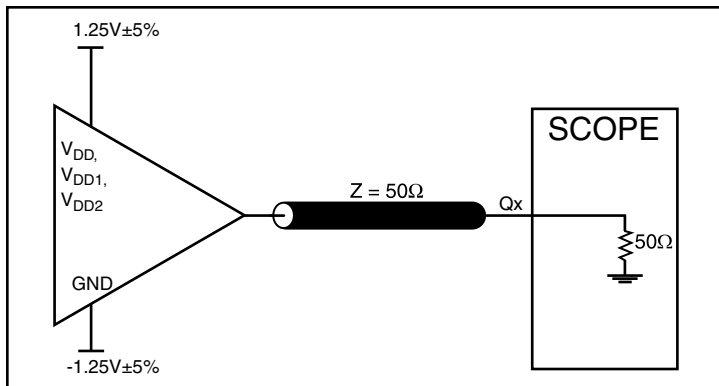

2.5V Core/2.5V Output Load Test Circuit

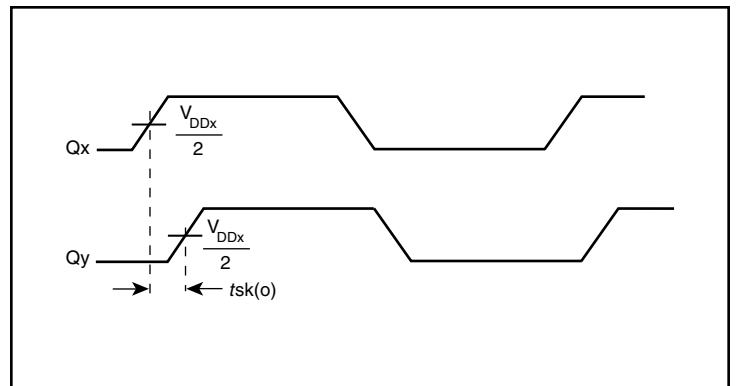

Output Skew

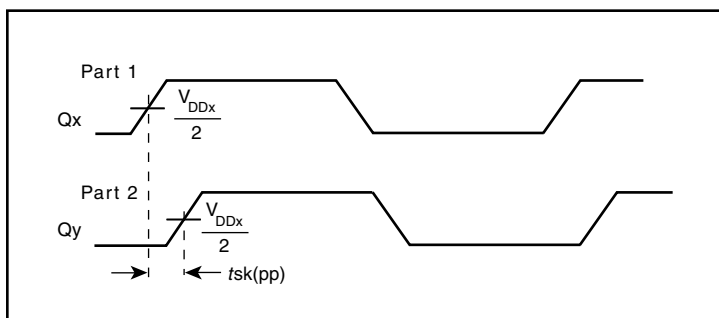

Part-to-Part Skew

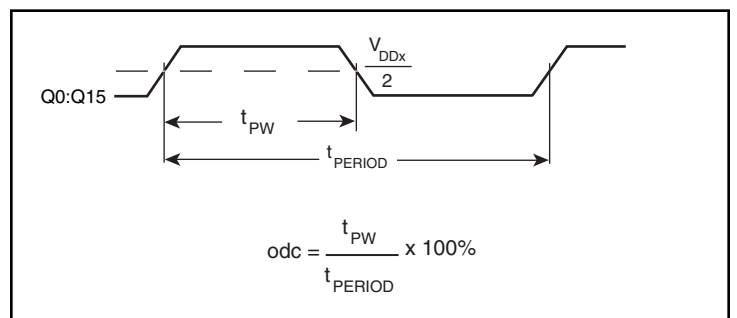

Output Duty Cycle/Pulse Width/Period

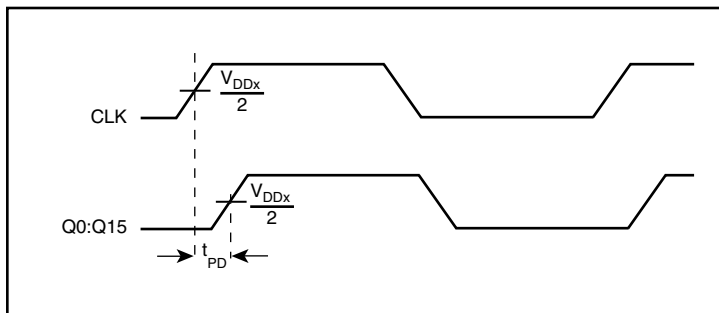

Propagation Delay

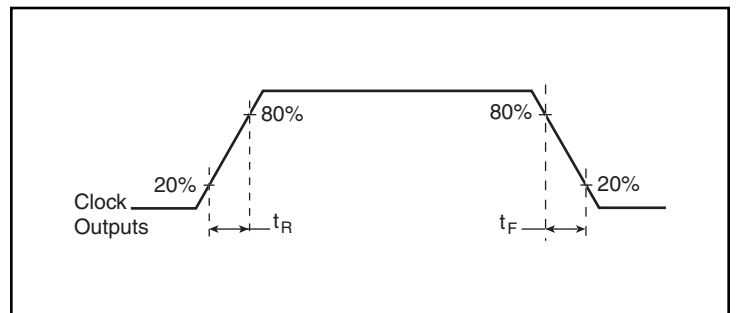

Output Rise/Fall Time

Reliability Information

Table 6. θ_{JA} vs. Air Flow Table for a 32-Lead LQFP¹

θ_{JA} by Velocity			
Linear Feet per Minute	0	200	500
Single-Layer PCB, JEDEC Standard Test Boards	67.8°C/W	55.9°C/W	50.1°C/W
Multi-Layer PCB, JEDEC Standard Test Boards	47.9°C/W	42.1°C/W	39.4°C/W

NOTE 1: Most modern PCB designs use multi-layered boards. The data in the second row pertains to most designs.

Transistor Count

The transistor count for 8343-01 is 985.

Package Outline and Package Dimensions

Package Outline - Y Suffix for 32-Lead LQFP

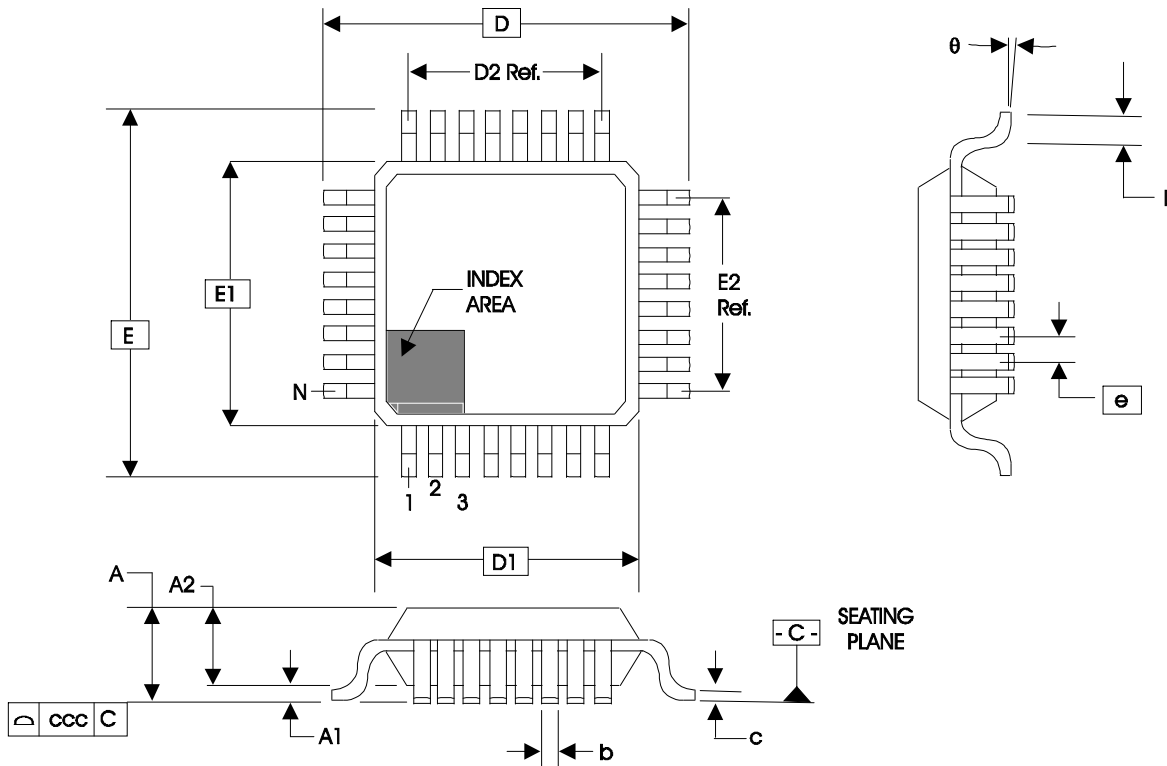

Table 7. Package Dimensions

JEDEC Variation All Dimensions in Millimeters			
Symbol	Minimum	Nominal	Maximum
N		32	
A	–	–	1.60
A1	0.05	–	0.15
A2	1.35	1.40	1.45
b	0.30	0.37	0.45
c	0.09	–	0.20
D	9.00 Basic		
D1	7.00 Basic		
D2	5.60 Ref.		
E	9.00 Basic		
E1	7.00 Basic		
E2	5.60 Ref.		
e	0.80 Basic		
L	0.45	0.60	0.75
θ	0°	–	7°
ccc	–	–	0.10

Ordering Information

Table 8. Ordering Information

Part/Order Number	Marking	Package	Shipping Packaging	Temperature
8343AY-01LF	ICS8343AY01L	"Lead-Free" 32-Lead LQFP	Tray	0°C to 70°C
8343AY-01LFT	ICS8343AY01L	"Lead-Free" 32-Lead LQFP	Tape & Reel	0°C to 70°C

Revision History Sheet

Rev	Table	Page	Description of Change	Date
A	T2	2	Pin Characteristics Table - changed C_{IN} 4pF max to 4pF typical. Added to R_{OUT} , 5 Ω min. and 12 Ω max.	9/18/03
	T8	11	Ordering Information correct package column from 48 Lead to 32 Lead.	
B	T5C	5	Added Mixed AC Characteristics Table. Updated format.	8/13/04
B	T8	9	Added Lead-Free marking to Ordering Information Table.	9/16/04
B		1	Updated format and contact information. General Description: Deleted HiPerClockS reference.	8/25/14
	T1	2	Re-organized table sequentially.	
	T8	10	Removed leaded option.	



Corporate Headquarters
6024 Silver Creek Valley Road
San Jose, CA 95138 USA

Sales
1-800-345-7015 or 408-284-8200
Fax: 408-284-2775
www.IDT.com

Tech Support
email: clocks@idt.com

DISCLAIMER Integrated Device Technology, Inc. (IDT) and its subsidiaries reserve the right to modify the products and/or specifications described herein at any time and at IDT's sole discretion. All information in this document, including descriptions of product features and performance, is subject to change without notice. Performance specifications and the operating parameters of the described products are determined in the independent state and are not guaranteed to perform the same way when installed in customer products. The information contained herein is provided without representation or warranty of any kind, whether express or implied, including, but not limited to, the suitability of IDT's products for any particular purpose, an implied warranty of merchantability, or non-infringement of the intellectual property rights of others. This document is presented only as a guide and does not convey any license under intellectual property rights of IDT or any third parties.

IDT's products are not intended for use in applications involving extreme environmental conditions or in life support systems or similar devices where the failure or malfunction of an IDT product can be reasonably expected to significantly affect the health or safety of users. Anyone using an IDT product in such a manner does so at their own risk, absent an express, written agreement by IDT.

While the information presented herein has been checked for both accuracy and reliability, Integrated Device Technology (IDT) assumes no responsibility for either its use or for the infringement of any patents or other rights of third parties, which would result from its use. No other circuits, patents, or licenses are implied. This product is intended for use in normal commercial applications. Any other applications, such as those requiring extended temperature ranges, high reliability or other extraordinary environmental requirements are not recommended without additional processing by IDT. IDT reserves the right to change any circuitry or specifications without notice. IDT does not authorize or warrant any IDT product for use in life support devices or critical medical instruments.

Integrated Device Technology, IDT and the IDT logo are registered trademarks of IDT. Product specification subject to change without notice. Other trademarks and service marks used herein, including protected names, logos and designs, are the property of IDT or their respective third party owners.

Copyright ©2014 Integrated Device Technology, Inc.. All rights reserved.



Стандарт Электрон Связь

Мы молодая и активно развивающаяся компания в области поставок электронных компонентов. Мы поставляем электронные компоненты отечественного и импортного производства напрямую от производителей и с крупнейших складов мира.

Благодаря сотрудничеству с мировыми поставщиками мы осуществляем комплексные и плановые поставки широчайшего спектра электронных компонентов.

Собственная эффективная логистика и склад в обеспечивает надежную поставку продукции в точно указанные сроки по всей России.

Мы осуществляем техническую поддержку нашим клиентам и предпродажную проверку качества продукции. На все поставляемые продукты мы предоставляем гарантию .

Осуществляем поставки продукции под контролем ВП МО РФ на предприятия военно-промышленного комплекса России , а также работаем в рамках 275 ФЗ с открытием отдельных счетов в уполномоченном банке. Система менеджмента качества компании соответствует требованиям ГОСТ ISO 9001.

Минимальные сроки поставки, гибкие цены, неограниченный ассортимент и индивидуальный подход к клиентам являются основой для выстраивания долгосрочного и эффективного сотрудничества с предприятиями радиоэлектронной промышленности, предприятиями ВПК и научно-исследовательскими институтами России.

С нами вы становитесь еще успешнее!

Наши контакты:

Телефон: +7 812 627 14 35

Электронная почта: sales@st-electron.ru

Адрес: 198099, Санкт-Петербург,
Промышленная ул, дом № 19, литера Н,
помещение 100-Н Офис 331