



STK672-630CN-E

Thick-Film Hybrid IC

2-phase Stepper Motor Driver

ON Semiconductor®

<http://onsemi.com>

Overview

The STK672-630CN-E is a hybrid IC for use as a unipolar, 2-phase stepper motor driver with PWM current control.

Applications

- Office photocopiers, printers, etc.

Features

- Built-in motor terminal open detection function(output current OFF).
There is a terminal to coordinate motor terminal open detection current.
- Built-in overcurrent detection function, overheat detection function (output current OFF).
- FAULT1 signal (active low) is output when any of motor terminal open, overcurrent or overheat is detected.
The FAULT2 signal is used to output the result of activation of protection circuit detection at 3 levels.
- Built-in power on reset function.
- The motor speed is controlled by the frequency of an external clock signal.
- 2 phase or 1-2 phase excitation switching function.
- Using either or both edges of the clock signal switching function.
- Phase is maintained even when the excitation mode is switched.
- Rotational direction switching function.
- Supports schmitt input for 2.5V high level input.
- Incorporating a current detection resistor (0.141Ω: resistor tolerance $\pm 2\%$), motor current can be set using two external resistors.
- The ENABLE pin can be used to cut output current while maintaining the excitation mode.
- With a wide current setting range, power consumption can be reduced during standby.
- No motor sound is generated during hold mode due to external excitation current control.
- Supports compatible pins with STK672-640CN-E.

Specifications

Absolute Maximum Ratings at Tc = 25°C

Parameter	Symbol	Conditions	Ratings	Unit
Maximum supply voltage 1	V _{CC} max	ENABLE=GND	50	V
Maximum supply voltage 2	V _{DD} max	No signal	-0.3 to 6.0	V
Input voltage	V _{in} max	Logic input pins	-0.3 to 6.0	V
Output current 1	IOP max	10μs 1 pulse (resistance load)	10	A
Output current 2	IOH max	V _{DD} = 5V, CLOCK ≥ 200Hz	2.65	A
Output current 3	IOF max	16pin Output current	10	mA
Allowable power dissipation 1	PdMF max	With an arbitrarily large heat sink. Per MOSFET	7.3	W
Allowable power dissipation 2	PdPK max	No heat sink	3.1	W
Operating substrate temperature	T _c max		105	°C
Junction temperature	T _j max		150	°C
Storage temperature	T _{stg}		-40 to 125	°C

Stresses exceeding those listed in the Maximum Ratings table may damage the device. If any of these limits are exceeded, device functionality should not be assumed, damage may occur and reliability may be affected.

ORDERING INFORMATION

See detailed ordering and shipping information on page 31 of this data sheet.

STK672-630CN-E

Allowable Operating Ranges at $T_c=25^\circ\text{C}$

Parameter	Symbol	Conditions	Ratings	unit
Operating supply voltage 1	V_{CC}	With signals applied	0 to 46	V
Operating supply voltage 2	V_{DD}	With signals applied	$5\pm 5\%$	V
Input high voltage	V_{IH}	Pins 10, 12, 13, 14, 15, 17, $V_{DD}=5\pm 5\%$	2.5 to V_{DD}	V
Input low voltage	V_{IL}	Pins 10, 12, 13, 14, 15, 17, $V_{DD}=5\pm 5\%$	0 to 0.8	V
Output current 1	I_{OH1}	$T_c=105^\circ\text{C}$, $CLOCK\geq 200\text{Hz}$, Continuous operation, duty=100%	2.0	A
Output current 2	I_{OH2}	$T_c=80^\circ\text{C}$, $CLOCK\geq 200\text{Hz}$, Continuous operation, duty=100%, See the motor current (I_{OH}) derating curve	2.2	A
CLOCK frequency	f_{CL}	Minimum pulse width: at least $10\mu\text{s}$	0 to 50	kHz
Recommended operating substrate temperature	T_c	No condensation	0 to 105	$^\circ\text{C}$
Recommended Vref range	Vref	$T_c=105^\circ\text{C}$	0.14 to 1.38	V

Functional operation above the stresses listed in the Recommended Operating Ranges is not implied. Extended exposure to stresses beyond the Recommended Operating Ranges limits may affect device reliability.

Electrical Characteristics at $T_c=25^\circ\text{C}$, $V_{CC}=24\text{V}$, $V_{DD}=5.0\text{V}$ *1

Parameter	Symbol	Conditions	min	typ	max	unit	
V_{DD} supply current	I_{CCO}	Pin 9 current, ENABLE=Low		5.0	8.0	mA	
Output average current *2	I_{oave}	$R/L=1\Omega/0.62\text{mH}$ in each phase	0.32	0.38	0.45	A	
FET diode forward voltage	Vdf	$I_f=1\text{A}$ ($R_L=23\Omega$)		0.92	1.6	V	
Output saturation voltage	Vsat	$R_L=23\Omega$		0.33	0.48	V	
Control Input pin	Input high voltage	V_{IH}	Pins 10, 12, 13, 14, 15, 17	2.5		V_{DD}	V
	Input low voltage	V_{IL}	Pins 10, 12, 13, 14, 15, 17	-0.3		0.8	V
	5V level input current	I_{ILH}	Pins 10, 12, 13, 14, 15, 17=5V		50	75	μA
	GND level input current	I_{ILL}	Pins 10, 12, 13, 14, 15, 17=GND			10	μA
FAULT 1 pin	Output low voltage	V_{OLF}	Pin 16 ($I_O=5\text{mA}$)		0.25	0.5	V
	5V level leakage current	I_{ILF}	Pin 16 =5V			10	μA
FAULT 2 pin	FAULT2 opened motor pin detection output voltage	V_{OF1}	Pin 8 (when all protection functions have been activated)	0.0	0.01	0.2	V
	FAULT2 Overcurrent detection output voltage	V_{OF2}		2.4	2.5	2.6	
	FAULT2 Overheat detection output voltage	V_{OF3}		3.1	3.2	3.5	
Vref input bias current	I_{IB}	Pin 19 =1.0V			1	μA	
PWM frequency	f_c		29	45	61	kHz	
Overheat detection temperature	TSD	Design guarantee		144		$^\circ\text{C}$	
Drain-source cut-off current	I_{DSS}	$V_{DS}=100\text{V}$, Pins 2, 6, 9, 18=GND			1	μA	

Notes

- *1: A fixed-voltage power supply must be used.
- *2: The value for I_{oave} assumes that the lead frame of the product is soldered to the mounting circuit board.
- *3: Maximum value of operating supply voltage 1 (V_{CC}) can not supply to STK672-6** series, depending on motor current value. Refer to "8. Other usage notes" of Technical data.

Product parametric performance is indicated in the Electrical Characteristics for the listed test conditions, unless otherwise noted. Product performance may not be indicated by the Electrical Characteristics if operated under different conditions.

STK672-630CN-E

Derating Curve of Motor Current, I_{OH} , vs. STK672-630CN-E Operating Substrate Temperature, T_c

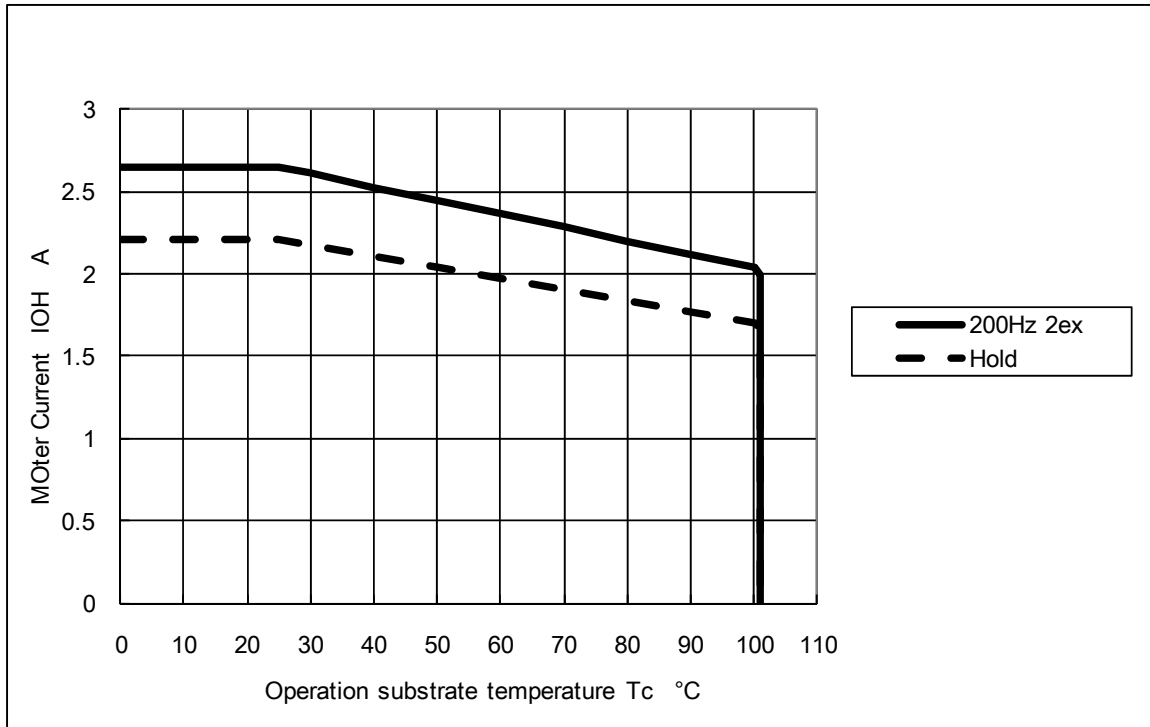

Notes

- The current range given above represents conditions when output voltage is not in the avalanche state.
- If the output voltage is in the avalanche state, see the allowable avalanche energy for STK672-6** series hybrid ICs given in a separate document.
- The operating substrate temperature, T_c , given above is measured while the motor is operating. Because T_c varies depending on the ambient temperature, T_a , the value of I_{OH} , and the continuous or intermittent operation of I_{OH} , always verify this value using an actual set.
- The T_c temperature should be checked in the center of the metal surface of the product package.

Block Diagram

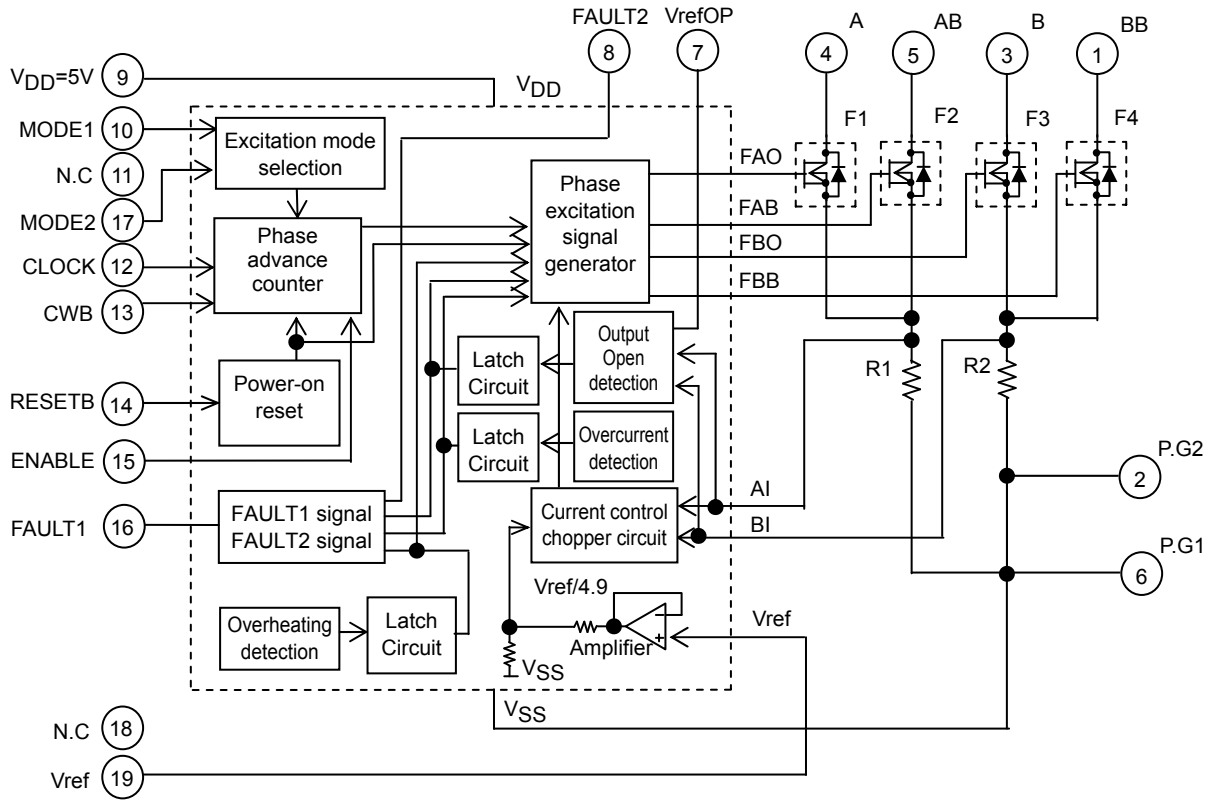

Measurement Circuit

(The terminal which is not appointed is open. The measurement circuit of STK672-630CN-E is the same as STK672-640CN-E.)

1. Vdf

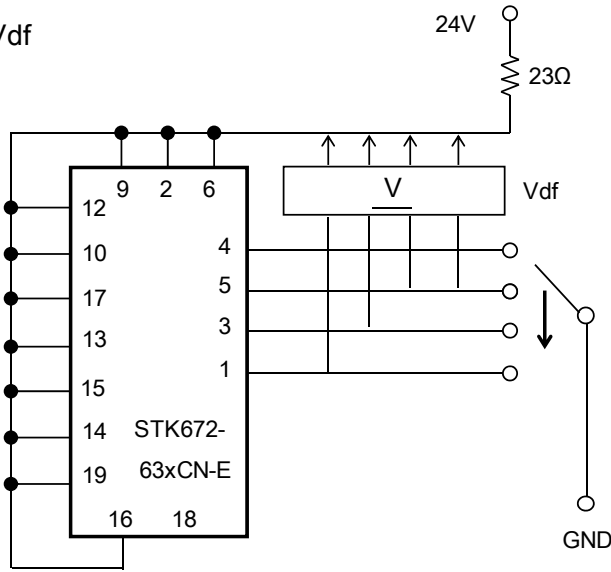

2. IILF, IILH, IILL, IIB

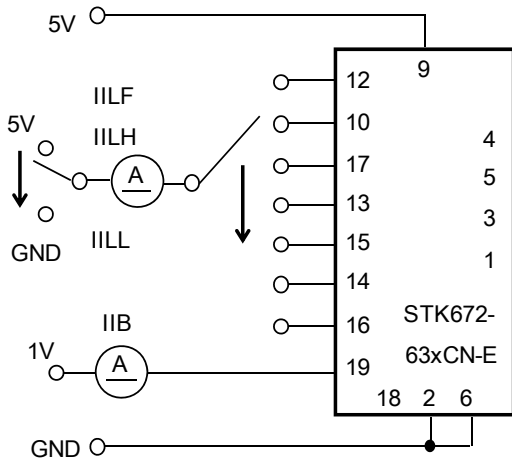

3. Vsat

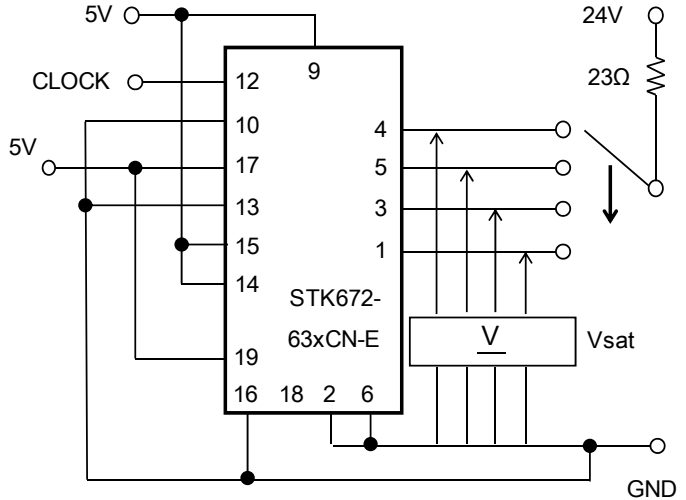

4. Icco, loave, fc, VOLF

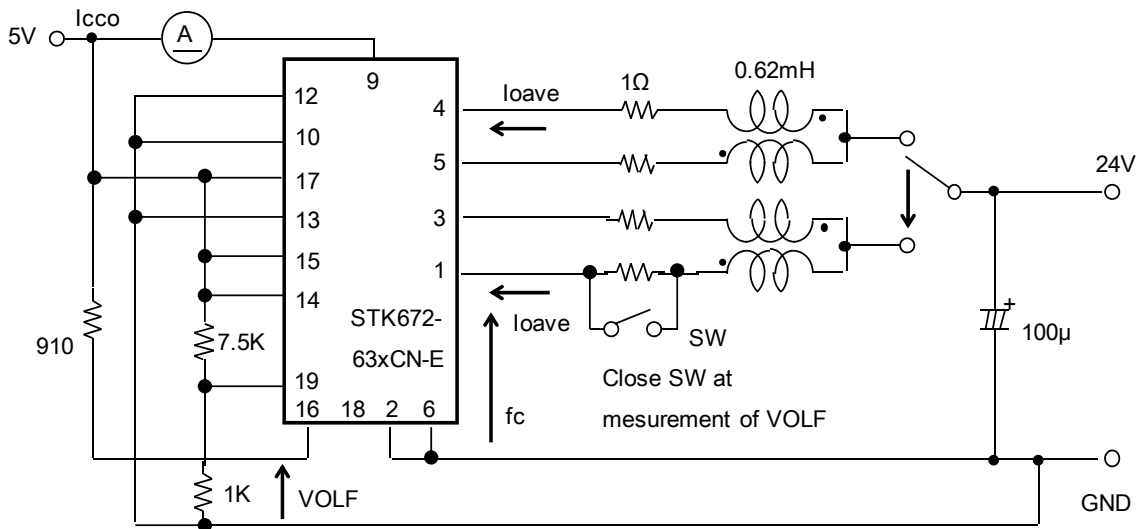

Sample Application Circuit

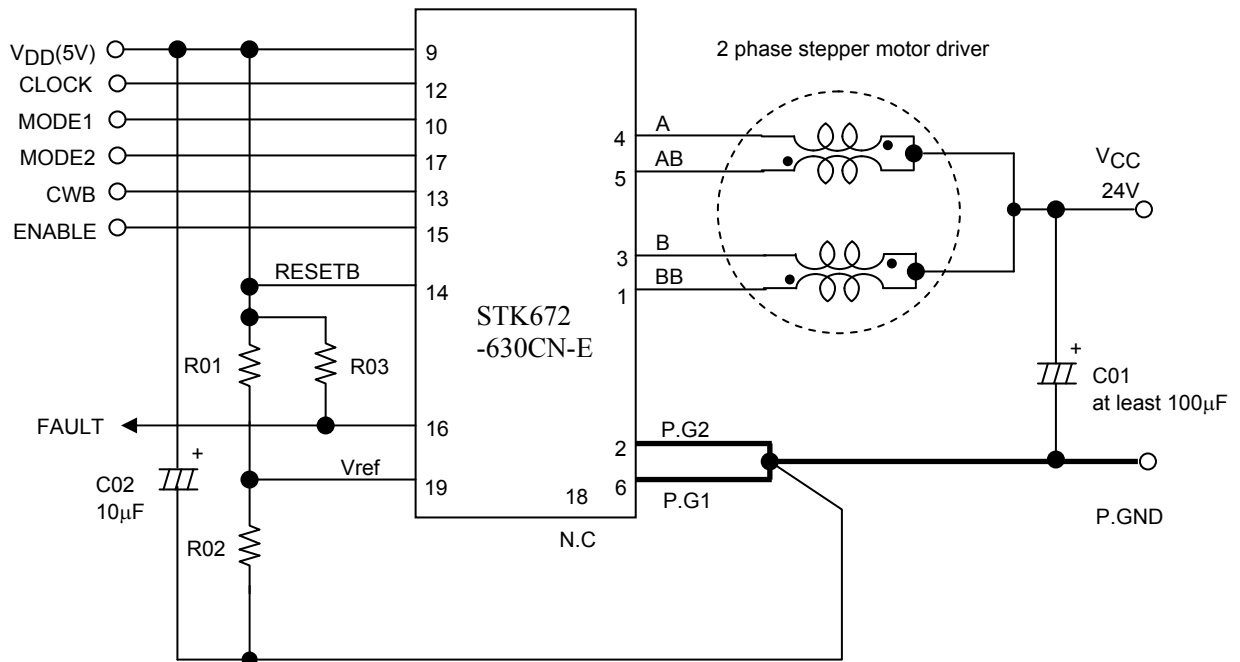

Precautions

[GND wiring]

- To reduce noise on the 5V/24V system, be sure to place the GND of C01 in the circuit given above as close as possible to Pin 2 and Pin 6 of the hybrid IC.
- In addition, in order to set the current accurately, the GND side of R02 of Vref must be connected to the shared ground terminal used by the Pin P.G1 and P.G2.

[Input pins]

- If VDD is being applied, use care that each input pin does not apply a negative voltage less than -0.3V to P. GND, Pin 2,6. Measures must also be taken so that a voltage equal to or greater than VDD is not input.
- Do not wire by connecting the circuit pattern on the P.C.B side to N.C Pins. shown in the internal block diagram.
- Apply 2.5V high level input to pins 10, 12, 13, 14, 15, and 17.
- Since the input pins do not have built-in pull-up resistors, when the open-collector type pins 10, 12, 13, 14, 15, and 17 are used as inputs, a 1 to 20kΩ pull-up resistor (to VDD) must be used.

At this time, use a device for the open collector driver that has output current specifications that pull the voltage down to less than 0.8V at Low level (less than 0.8V at Low level when $I_{OL}=5mA$).

[Current setting Vref]

Considering the specifications for the Vref input bias current IIB, we recommend a value 1kΩ or less for R02. If the motor current is temporarily reduced, the circuit given below(STK672-630CN-E: $I_{OH}>0.2A$) is recommended.

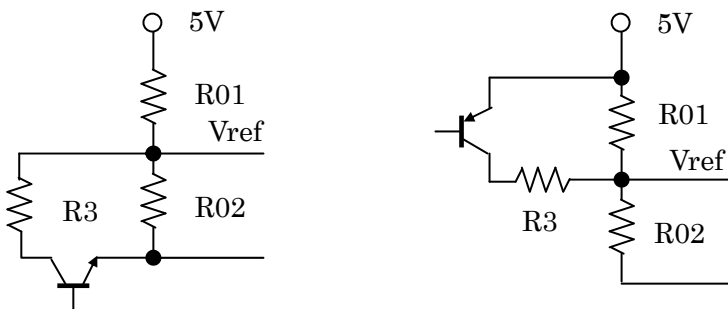

STK672-630CN-E

[Setting the motor current]

The motor current, I_{OH} , is set using the Pin 19 voltage, V_{ref} , of the hybrid IC.

Equations related to I_{OH} and V_{ref} are given below.

$$V_{ref} \approx (RO2 \div (RO2+RO1)) \times V_{DD}(5V) \quad \dots\dots\dots (1)$$

$$I_{OH} \approx (V_{ref} \div 4.9) \div R_s \quad \dots\dots\dots (2)$$

The value of 4.9 in Equation (2) above represents the V_{ref} voltage as divided by a circuit inside the control IC.

R_s : 0.141Ω (Current detection resistor inside the hybrid IC)

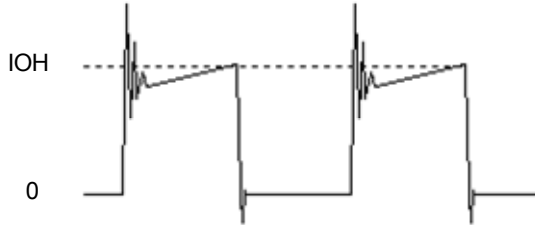

Input Pin Functions

Pin Name	Pin No.	Function	Input Conditions When Operating
CLOCK	12	Reference clock for motor phase current switching	Operates on the rising edge of the signal (MODE2=H)
MODE1	10	Excitation mode selection	Low: 2-phase excitation High: 1-2 phase excitation
MODE2	17		High: Rising edge Low: Rising and falling edge
CWB	13	Motor direction switching	Low: CW (forward) High: CCW (reverse)
RESETB	14	System reset Initial state of A and BB phase excitation in the timing charts is set by switching from low to high.	A reset is applied by a low level
ENABLE	15	The A, AB, B, and BB outputs are turned off, and after operation is restored by returning the ENABLE pin to the high level, operation continues with the same excitation timing as before the low-level input.	The A, AB, B, and BB outputs are turned off by a low-level input.

Output Pin Functions

Pin Name	Pin No.	Function	Input Conditions When Operating
FAULT1	16	Monitor pin used when over-current detection or overheat detection function is activated.	Low level is output when detected.
FAULT2	8	The result of activation of protection circuit detection is output.	3 levels output voltage
VrefOP	7	Monitor pin of reference voltage used when opened motor terminal detection.	Normal DC voltage output (typ98mV)

Note : See the timing chart for the concrete details on circuit operation.

Timing Charts

2-phase excitation

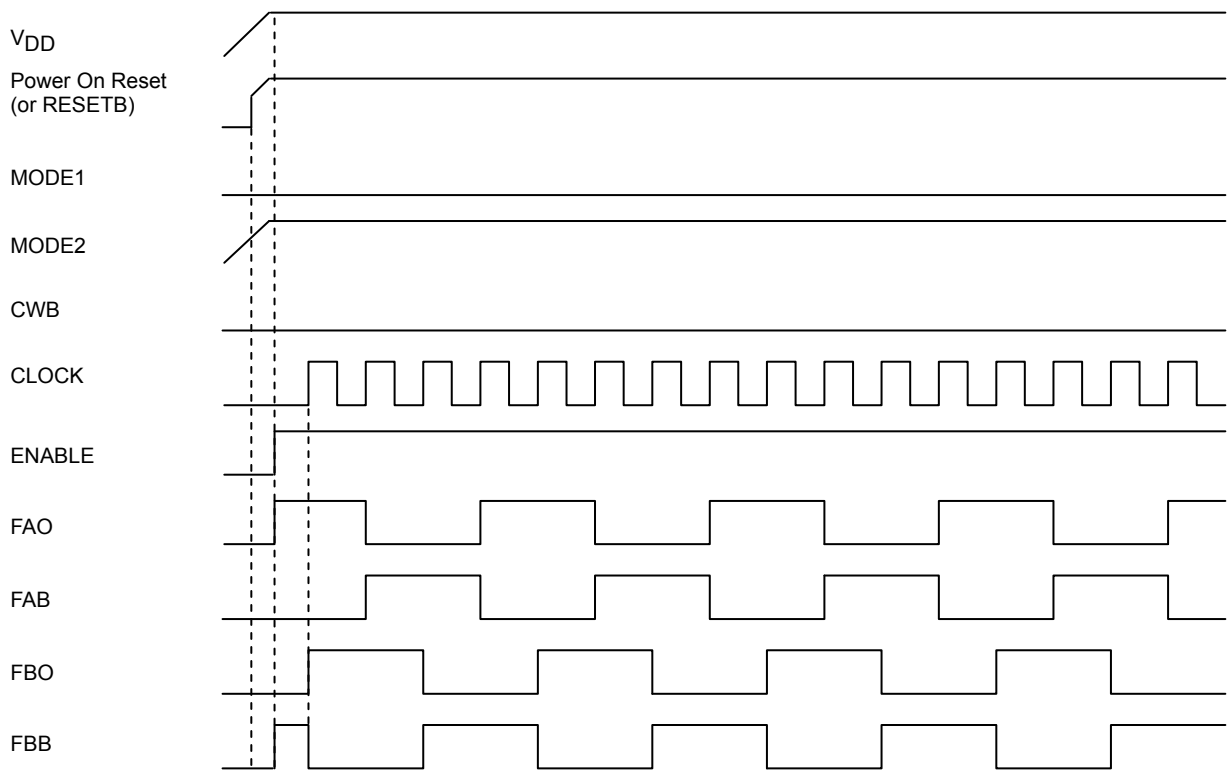

1-2 phase excitation

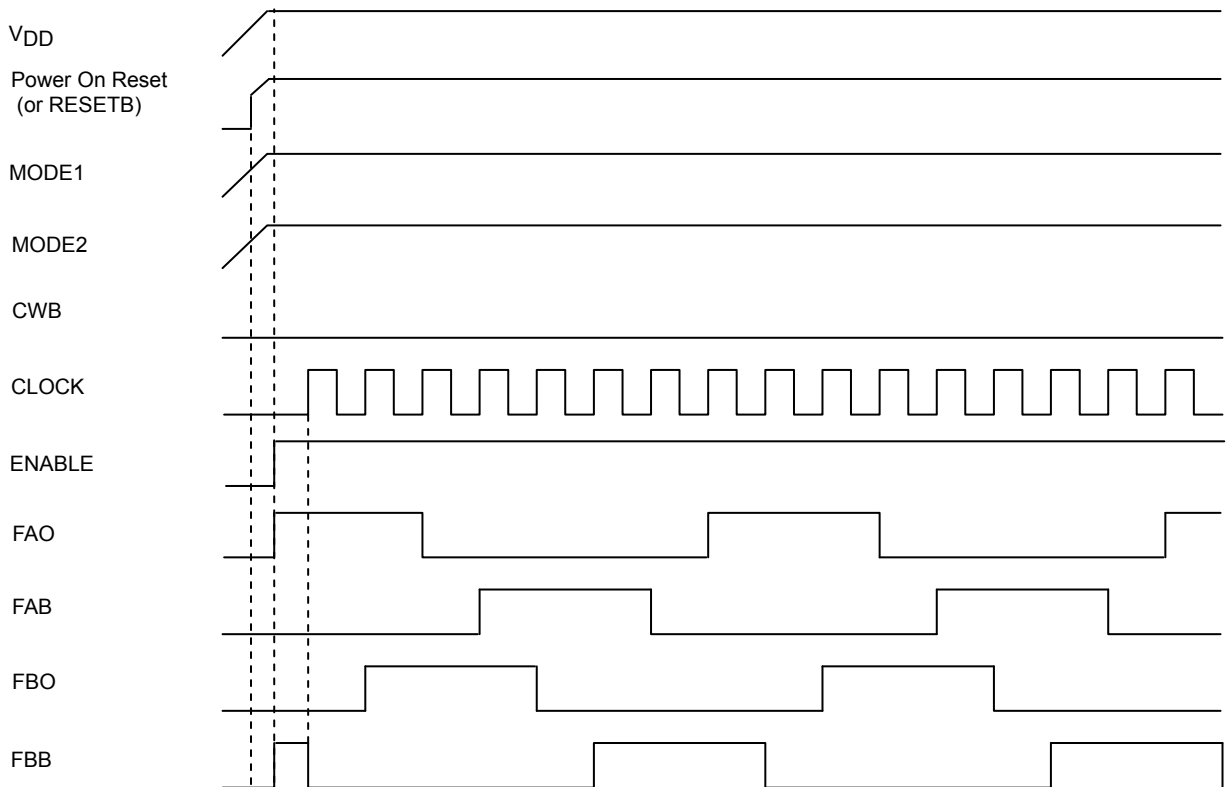

STK672-630CN-E

1-2 phase excitation (CWB)

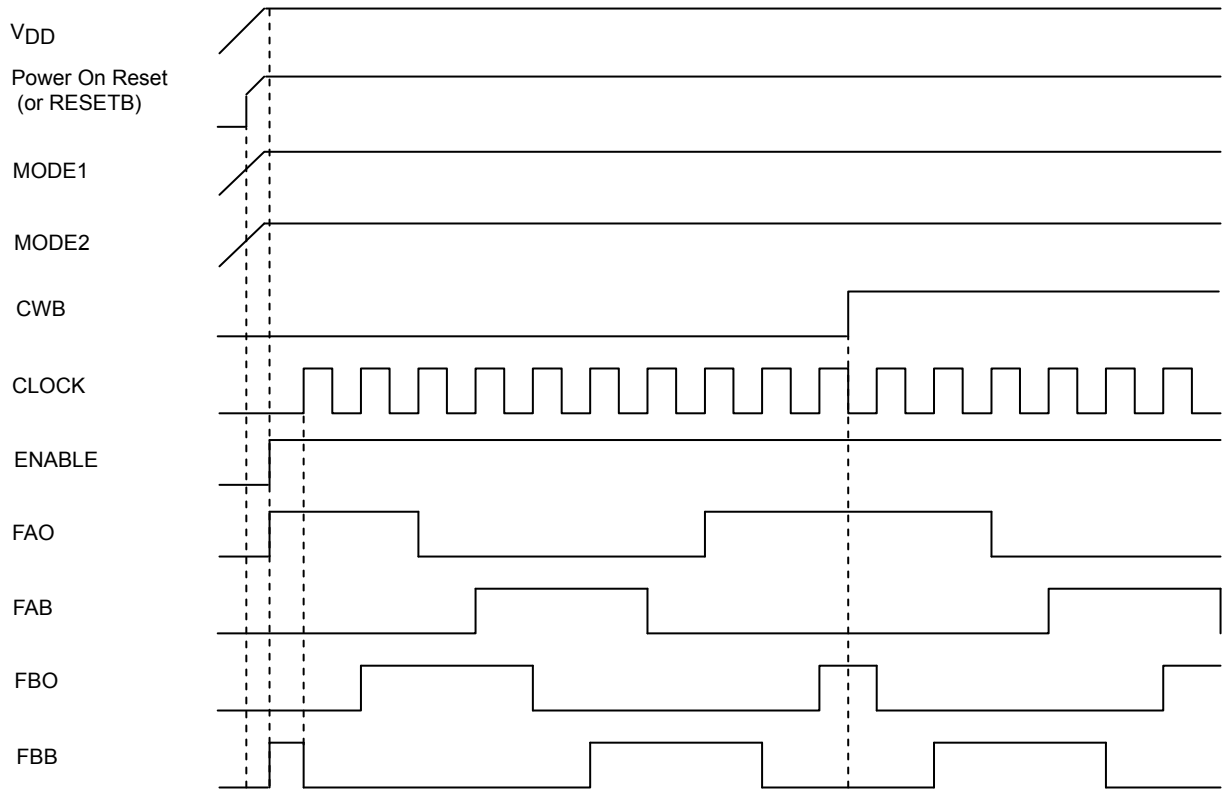

2 phase excitation → Switch to 1-2 phase excitation

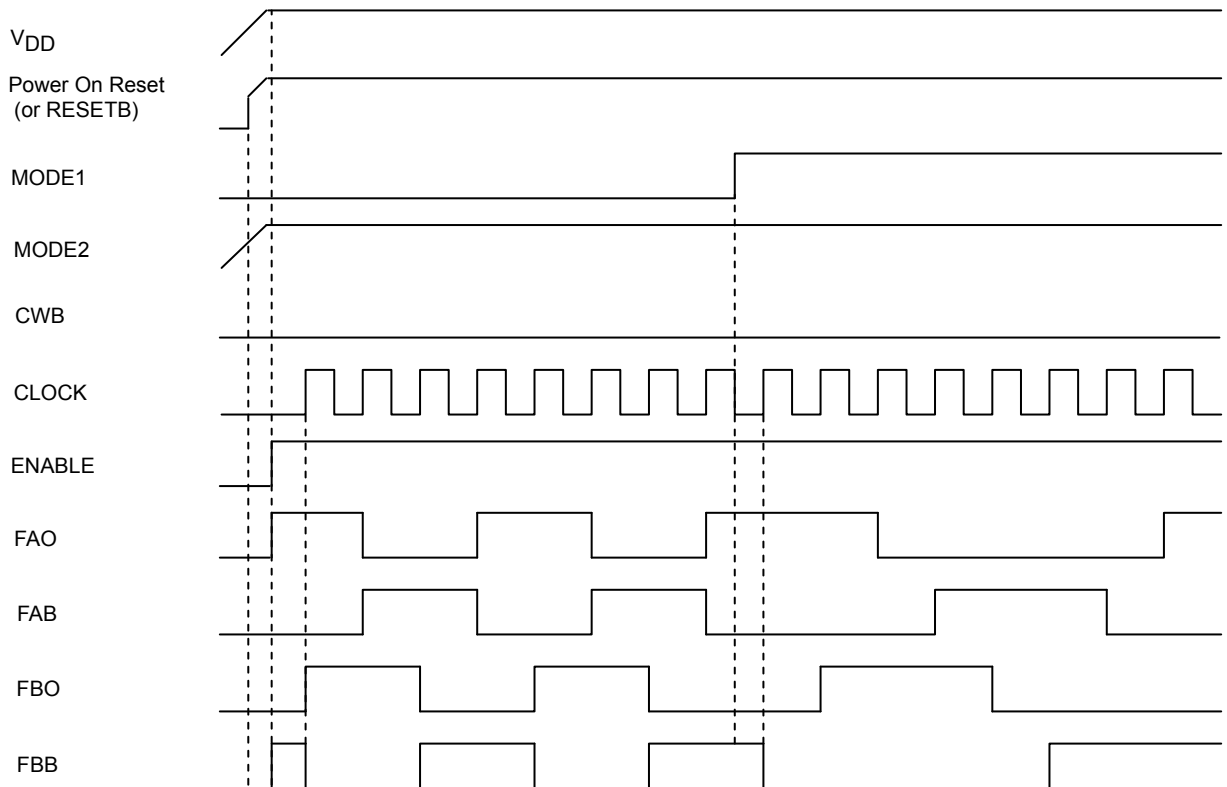

STK672-630CN-E

1-2 phase excitation (ENABLE)

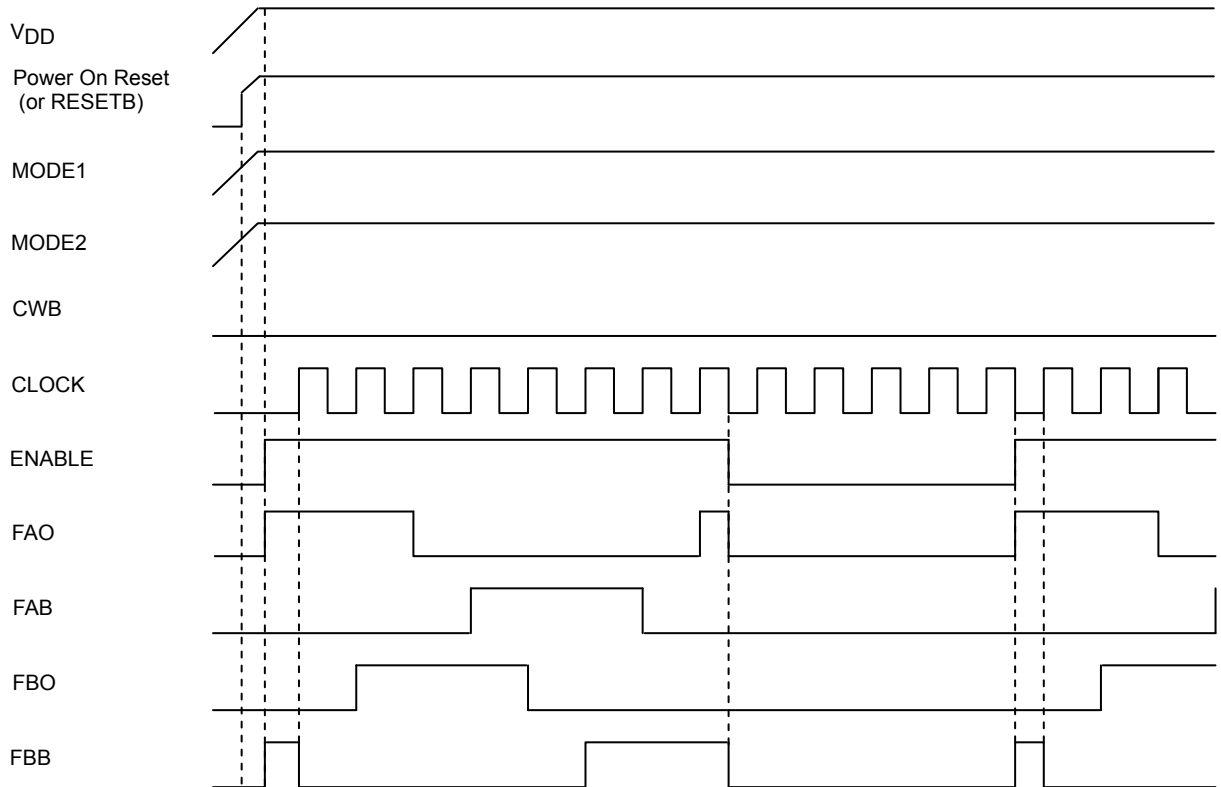

1-2 phase excitation (Hold operation results during fixed CLOCK)

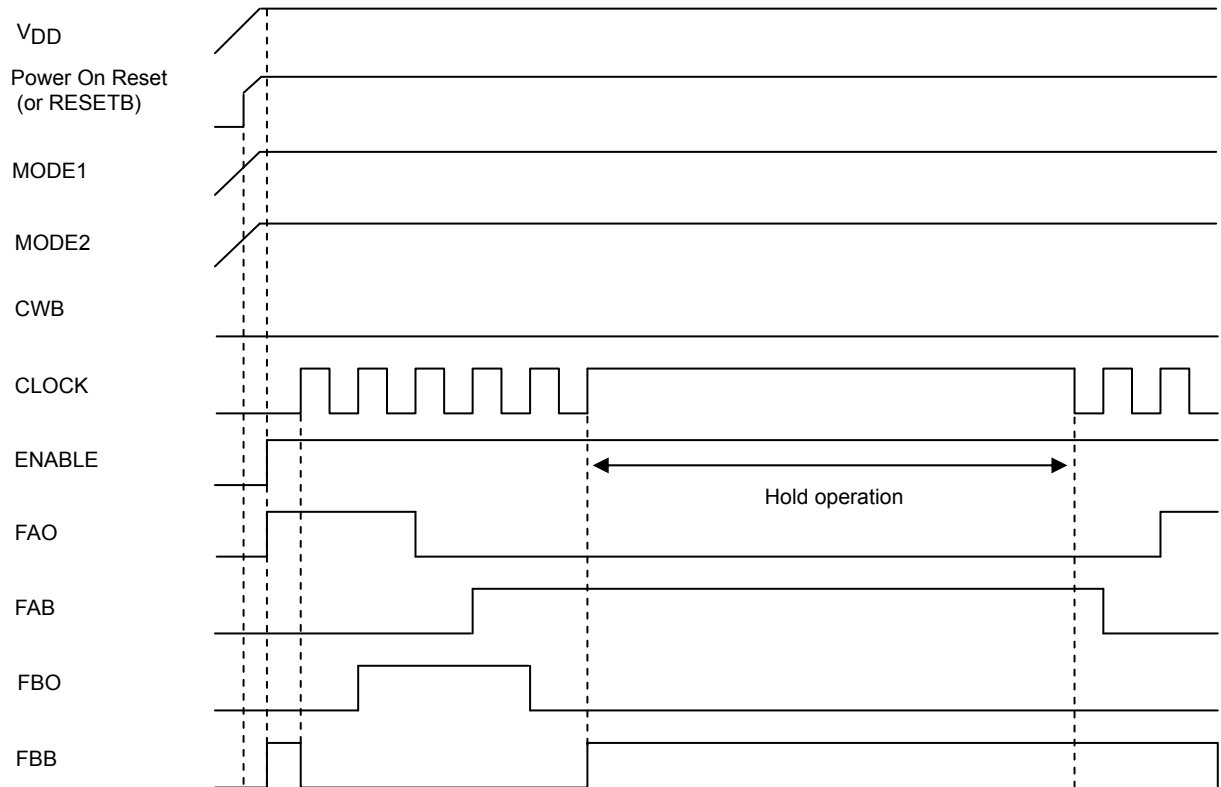

2 phase excitation (MODE 2)

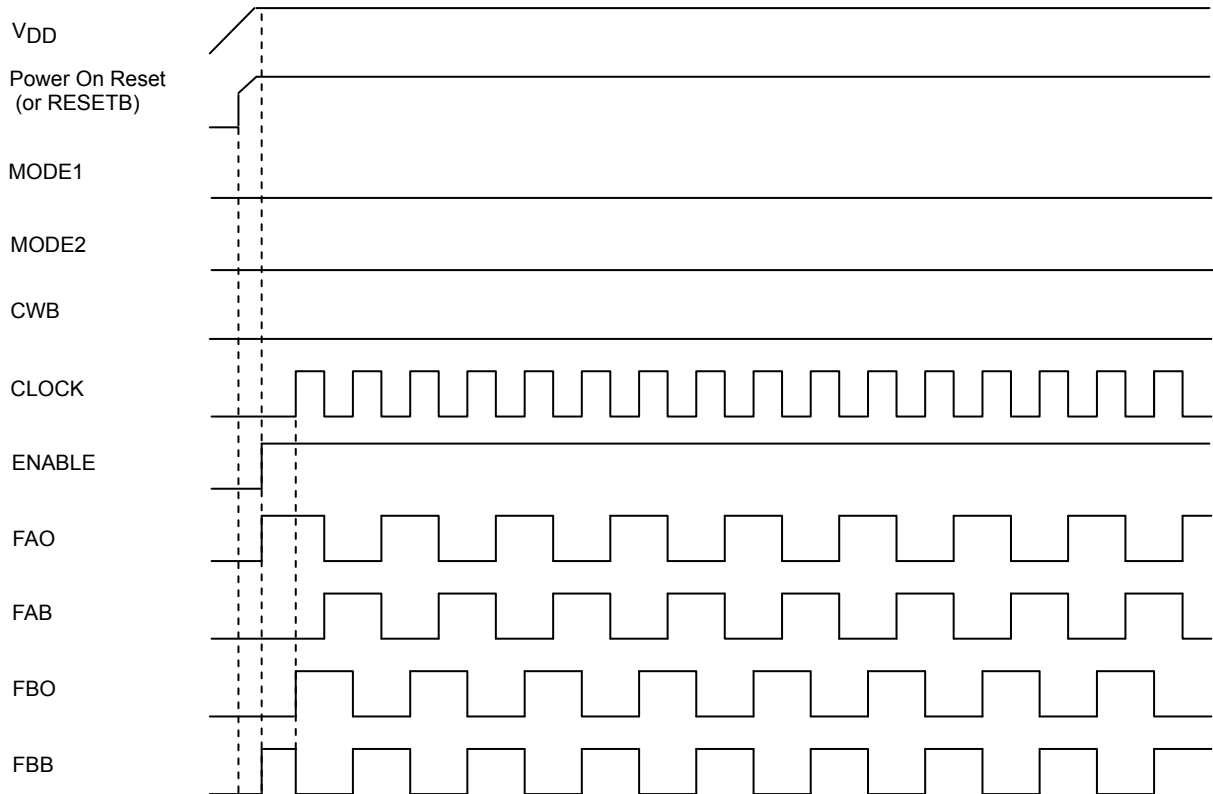

1-2 phase excitation (MODE 2)

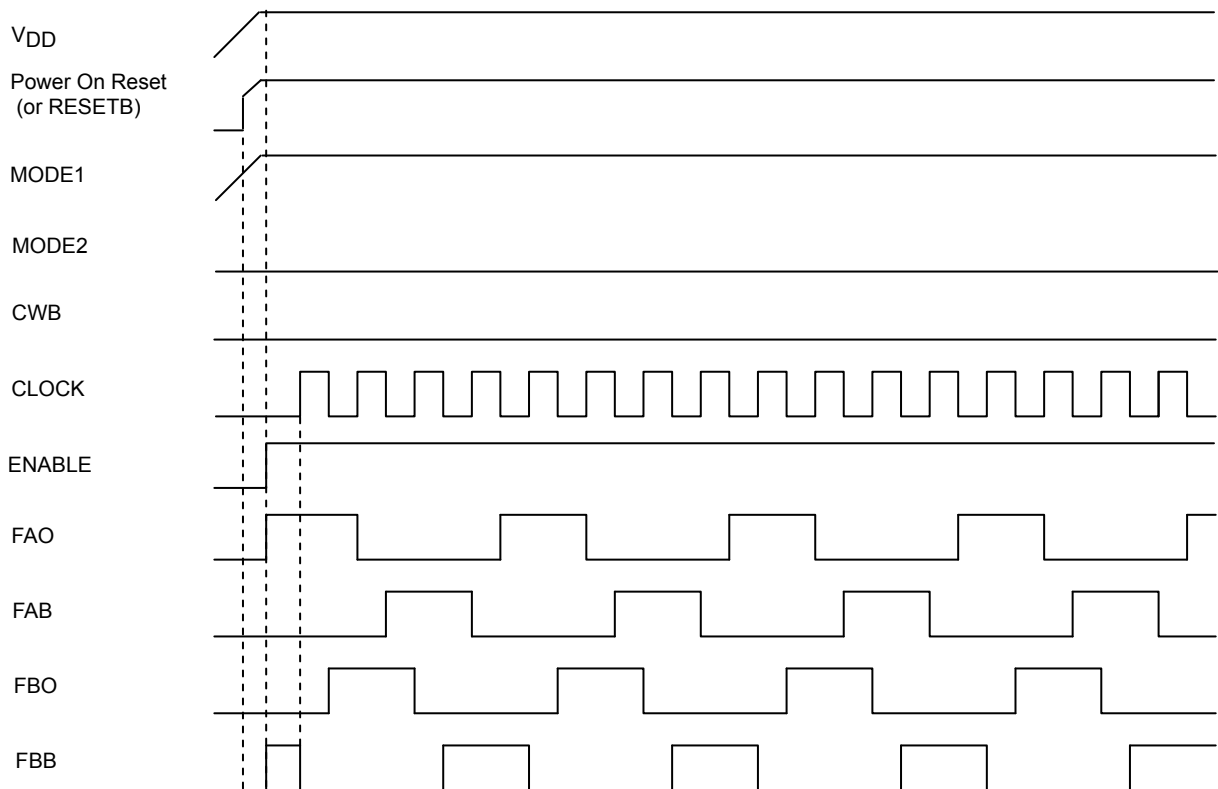

STK672-630CN-E

Package Dimensions

unit : mm

SIP19 29.2x14.4

CASE 127CF

ISSUE 0

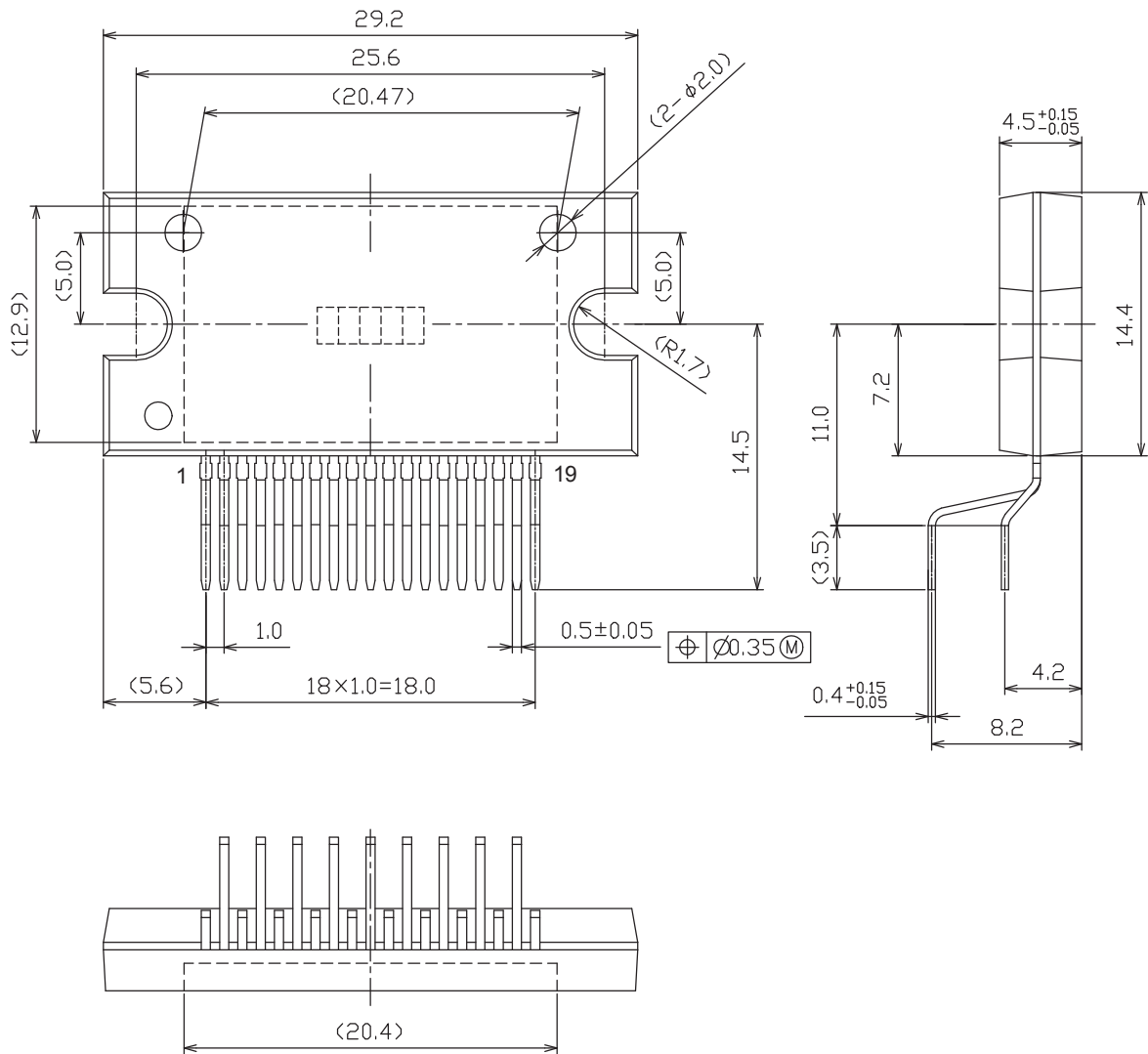

STK672-630CN-E
Technical data

1. Input Pins and Functional Overview
2. STK672-630CN-E over current detection, thermal shutdown detection.
3. STK672-630CN-E Allowable Avalanche Energy
4. STK672-630CN-E Internal Loss Calculation
5. Thermal Design
6. Package Power Loss PdPK Derating Curve for the Ambient Temperature Ta
7. Example of Stepper Motor Driver Output Current Path (1-2 phase excitation)
8. Other usage notes

STK672-630CN-E

1. I/O Pins and Functions of the Control Block

[Pin description]

HIC pin	Pin Name	Function
10	MODE1	Excitation mode selection
17	MODE2	
12	CLOCK	External CLOCK (motor rotation instruction)
13	CWB	Sets the direction of rotation of the motor axis
14	RESETB	System reset
15	ENABLE	Motor current OFF
16	FAULT1	Motor terminal open /Overcurrent /over-heat detection output
8	FAULT2	
7	VrefOP	Monitor pin of reference voltage used when opened motor terminal detection.
19	Vref	Current value setting

Description of each pin

1-1. [MODE1, MODE2 (Selecting the excitation mode, and selecting one edge or both edges of the CLOCK)]

Excitation select mode terminal (7pages of input pin functions for excitation mode selection), selecting the CLOCK input edge(s).Mode setting active timing

MODE1=0: 2-phase excitation

MODE2=1: Rising edge of CLOCK

MODE1=1: 1-2 phase excitation

MODE2=0: Rising and falling edges of CLOCK

See the timing charts for details on output operation in these modes.

Note: Do not change the mode within 5 μ s of the input rising or falling edge of the CLOCK signal.

1-2.[CLOCK (Phase switching clock)]

Input frequency: DC-20kHz (when using both edges) or DC-50kHz (when using one edge)

Minimum pulse width: 20 μ s (when using both edges) or 10 μ s (when using one edge)

Pulse width duty: 40% to 50% (when using both edges)

Both edge, single edge operation

MODE2:1 The excitation phase moves one step at a time at the rising edge of the CLOCK pulse.

MODE2:0 The excitation phase moves alternately one step at a time at the rising and falling edges of the CLOCK pulse.

1-3.[CWB (Motor direction setting)]

When CWB=0: The motor rotates in the clockwise direction.

When CWB=1: The motor rotates in the counterclockwise direction.

See the timing charts for details on the operation of the outputs.

Note: Do not allow CWB input to vary during the 6.25 μ s interval before and after the rising and falling edges of CLOCK input.

1-4.[RESETB (System-wide reset)]

The reset signal is formed by the power-on reset function built into the HIC and the RESETB terminal.

When activating the internal circuits of the HIC using the power-on reset signal within the HIC, be sure to connect Pin 14 of the HIC to V_{DD}.

1-5. [ENABLE (Forcible OFF control of excitation drive output A, AB, B, and BB, and selecting operation/hold status inside the HIC)]

ENABLE=1: Normal operation

When ENABLE=0: Motor current goes OFF, and excitation drive output is forcibly turned OFF.

The system clock inside the HIC stops at this time, with no effect on the HIC even if input pins other than RESET input vary. In addition, since current does not flow to the motor, the motor shaft becomes free.

If the CLOCK signal used for motor rotation suddenly stops, the motor shaft may advance beyond the control position due to inertia. A SLOW DOWN setting where the CLOCK cycle gradually decreases is required in order to stop at the control position.

1-6. [FAULT1]

FAULT1 is an open drain output. It outputs low level when any of motor terminal open, overcurrent, or overheat is detected.

1-7. [FAULT2]

Output is resistance divided (3 levels) and the type of abnormality detected is converted to the corresponding output voltage.

- Motor terminal open: 10mV (typ)
- Overcurrent: 2.5V (typ)
- Overheat: 3.3V (typ)

Abnormality detection can be released by a RESETB operation or turning V_{DD} voltage on/off.

1-8. [VrefOP]

To set the motor current detection circuit operates when pin is open, to monitor the reference voltage VrefOP terminal. It is also possible to set any detectable current by connecting an external pull-up resistor to 5V supply.

<I_{OHd} by setting pull-up resistor current sensing pin 7 open>

When 7 pins open, VrefOP (typ) is 98mV. In this case, detection current I_{OHd} is expressed as follows.

$$V_{refOP} = I_{OHd} \times R_s \quad (R_s: \text{Current detection resistor})$$

Detection current is 0.7A for the STK672-630CN-E, 1.1A for the STK672-640CN-E motor drivers.

Note: Detective current IOHdX is greatly set when used 5V pulling up resistance.

Reference voltage VrefOPX is calculated as above. Pull-up resistor Rdx by pin 7 is calculated as follows.

$$R_{dX} = (180 \times R_{TX}) \div (180 - R_{TX})$$

$$R_{TX} = (5.0V - V_{refOPX}) \div ((1.0588 \times V_{refOPX}) - 0.0765) \quad (R_{dX} \text{ and } R_{TX} \text{ unit is } k\Omega)$$

*To disable pin open detection, please connect a 5V pull-up resistor of 10k to 15k Ω .

1-9.[Vref (Voltage setting to be used for the current setting reference)]

Input voltage is in the voltage range of 0.14V to 1.38V.

The recommended Vref voltage is 0.14V or higher because the output offset voltage of Vref/4.9 amplifier cannot be controlled down to 0V.

Note: Pin type is analog input configuration.

1-10. [Input timing]

The control IC of the driver is equipped with a power on reset function capable of initializing internal IC operations when power is supplied. A 4V typ setting is used for power on reset. Because the specification for the MOSFET gate voltage is 5V \pm 5%, conduction of current to output at the time of power on reset adds electromotive stress to the MOSFET due to lack of gate voltage. To prevent electromotive stress, be sure to set ENABLE=Low while V_{DD}, which is outside the operating supply voltage, is less than 4.75V.

In addition, if the RESETB terminal is used to initialize output timing, be sure to allow at least 10 μ s until CLOCK input.

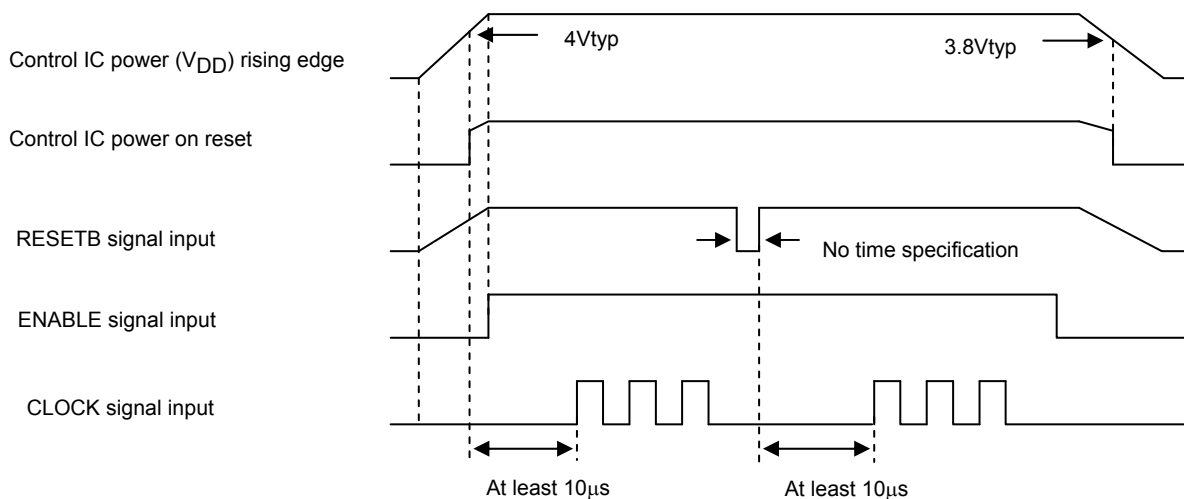

ENABLE, CLOCK, and RESETB Signals Input Timing

1-11. [Configuration of control block I/O pins]

<Configuration of the MODE1, MODE2, CLOCK, CWB, ENABLE, and RESETB input pins>
 Input pins 10,12,13,14,15,17pin

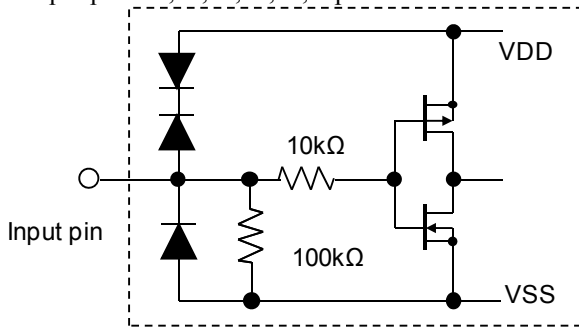

<Configuration of the FAULT2 pin>

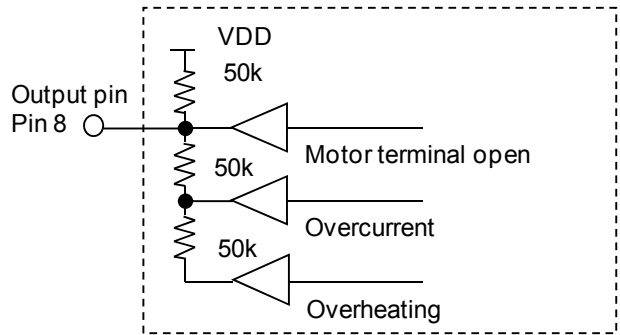

(The buffer has an open drain configuration.)

The input pins of this driver all use Schmitt input. Typical specifications at $T_c=25^\circ\text{C}$ are given below. Hysteresis voltage is 0.3V ($V_{IHa}-V_{ILa}$).

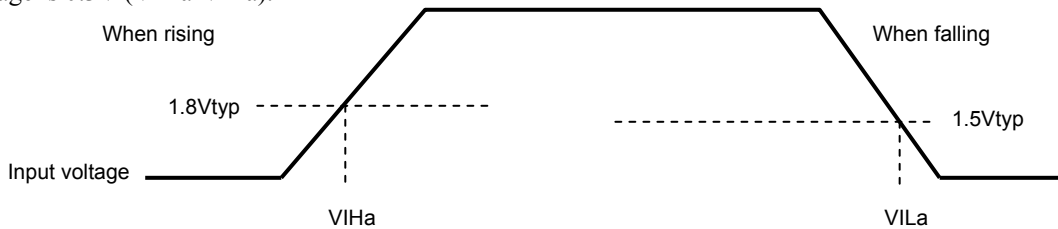

Input voltage specifications are as follows.

$V_{IH}=2.5\text{Vmin}$
 $V_{IL}=0.8\text{Vmax}$

<Configuration of the Vref input pin>

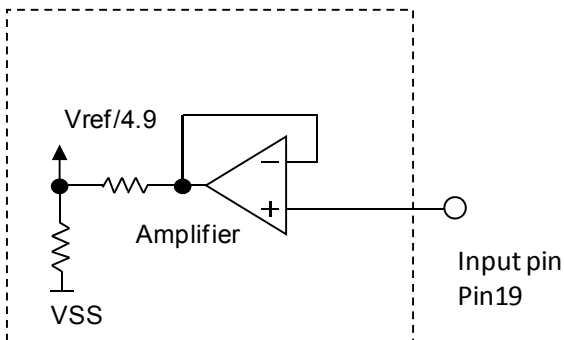

<Configuration of the FAULT output pin>

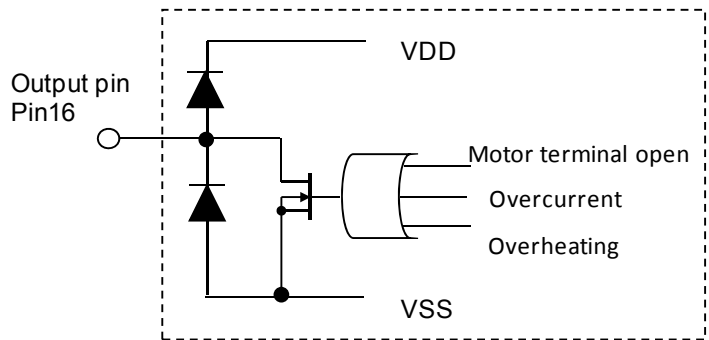

<Configuration of the VrefOP output pin>

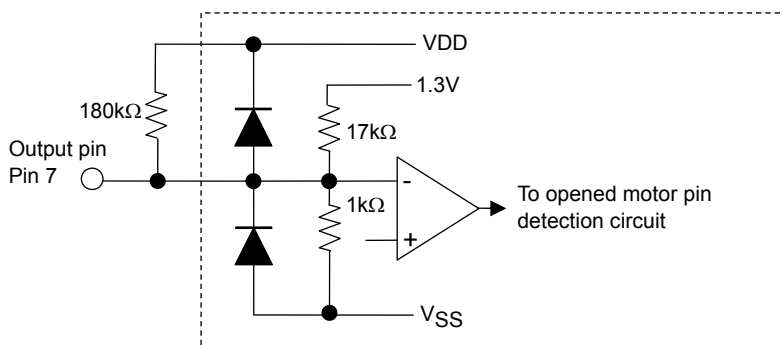

2. Overcurrent detection, overheat detection, and motor terminal open functions

Each detection function operates using a latch system and turns output off. Because a RESET signal is required to restore output operations, once the power supply, VDD, is turned off, you must either again apply power on reset with VDDON or apply a RESETB=High→Low→High signal.

2-1.[Motor terminal open detection]

This hybrid IC is equipped with a function for detecting open output terminals to prevent thermal destruction of the MOSFET due to repeated avalanche operation that occurs when an output terminal connected to the motor is open. The open condition is determined by checking the presence or absence of the flyback current that flows in the motor inductance during the off period of the PWM cycle.

Detection is performed by using the fact that the flyback current does not flow when a motor terminal is open.

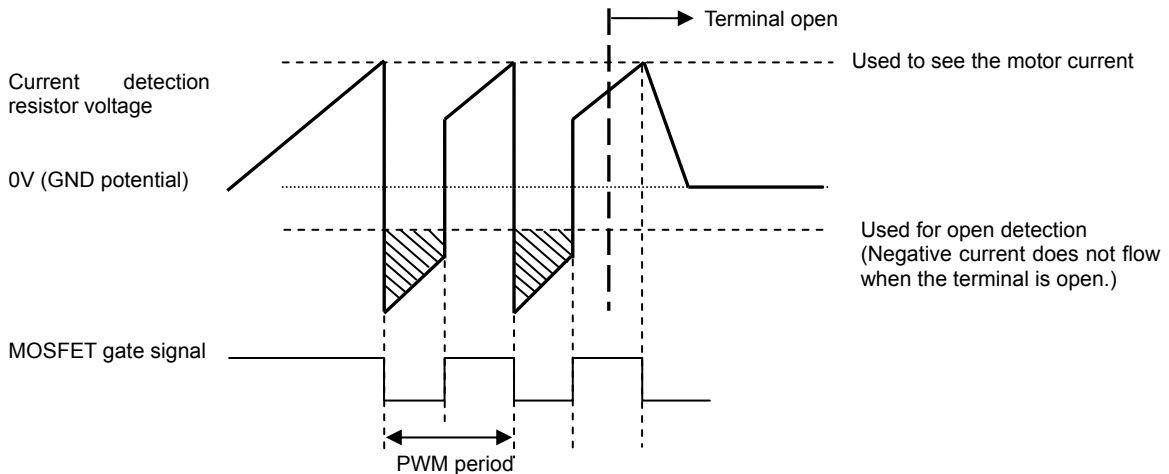

When the current level drops, the difference with the GND potential decreases, making detection difficult.

The motor current that can be detected by motor terminal open detection is 0.7A for the STK672-630CN-E, 1.1A for the STK672-640CN-E motor drivers

<Notes on the ENABLE high edge>

When ENABLE changes from low to high and the STK672-6xxCN-E performs constant-current PWM operation that flows a negative current during the 30μs period after the high edge, open detection may activate and stop the driver. The motor current setting voltage Vref must be set so that PWM operation is not performed within a period of 30μs after the high edge.

If the motor current setup voltage is set for the rated motor current, PWM operation is not performed during this 30μs period after the high edge, so this is not a problem.

In addition, there is no problem with operation that lowers the current setting Vref after the motor rated current is reached as shown in the diagram on the following page.

Whether constant-current PWM operation is performed during the 30μs period after the high edge can be judged by substituting the motor L and R values into the formula on the following page.

$$V_{ref} = (R02 \div (R01+R02)) \times 5V \text{ (or } 3.3V)$$

$$I_{OH1} = (V_{ref} \div 4.9) \div R_s \quad I_{OH1}: \text{ Motor current value to be set}$$

$$I_{OH2} = (V_{CC} \div R) \times (1 - e^{-tR/L}) \quad I_{OH2}: \text{ Current value } 30\mu s \text{ after the ENABLE high edge}$$

$$\Rightarrow \text{Judgment standard: } I_{OH1} > I_{OH2}$$

R01, R02, 5V (or 3.3V): See the Sample Application Circuit documents.

Rs: Current detection resistance value (Ω)

VCC: Motor supply voltage (V)

R: Motor winding resistance (Ω)

L: Motor winding inductance (H)

⇒ There is no problem if the IOH2 obtained by substituting t = 30μs and the motor L and R values is smaller than the current setting value IOH1.

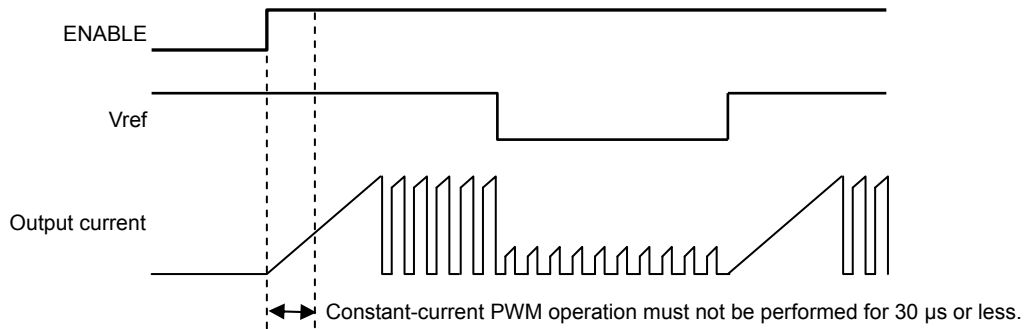

<Connection of capacitors between output pins and GND prohibited>

Capacitors must not be connected between the phase A (pin 4), phase AB (pin 5), phase B (pin 3) and phase BB (pin 1) outputs and GND. What happens if capacitors are connected is that open-circuit detection may be triggered by the discharge current of the capacitors when the internal MOSFET is set ON. This current is not an inductance current generated by the motor winding but a capacitor current so a negative current will not flow to the other phase in each pair of phases, possibly causing the driver to shut down.

<Excessive external noise>

If, when the motor current rises prior to the PWM operation, a spike-shaped current exceeding the Vref-setting current is generated by excessive external noise, for instance, before the current level (0.7A for the STK672-630CN-E, 1.1A for the STK672-640CN-E motor drivers) at which motor pin open-circuiting can be detected is reached, the internal MOSFET is set OFF.

Since the MOSFET has been set OFF before the actual motor current reaches 0.7A (or 1.1A), the level of the negative current subsequently flowing to the other phase in each pair of phases is low, and it may be judged that no negative current is flowing, possibly causing open-circuit detection to be triggered.

During normal constant-current PWM operation, the duration of 5.5μs, which is equivalent to 25% of the initial operation in the PWM period, corresponds to the section where the current is not detected, and this ensures that no current is detected for the linking part of the current that is generated in this section. The no-current detection section is not synchronized at the current rise prior to the PWM operation so when a spike-shaped current exceeding the Vref-setting current is generated, the MOSFET is set OFF at the stage where the level of the actual motor current is low. As a result, the level of the negative current subsequently flowing to the other phase in each pair of phases is low, and it may be judged that no negative current is flowing, possibly causing open-circuit detection to be triggered.

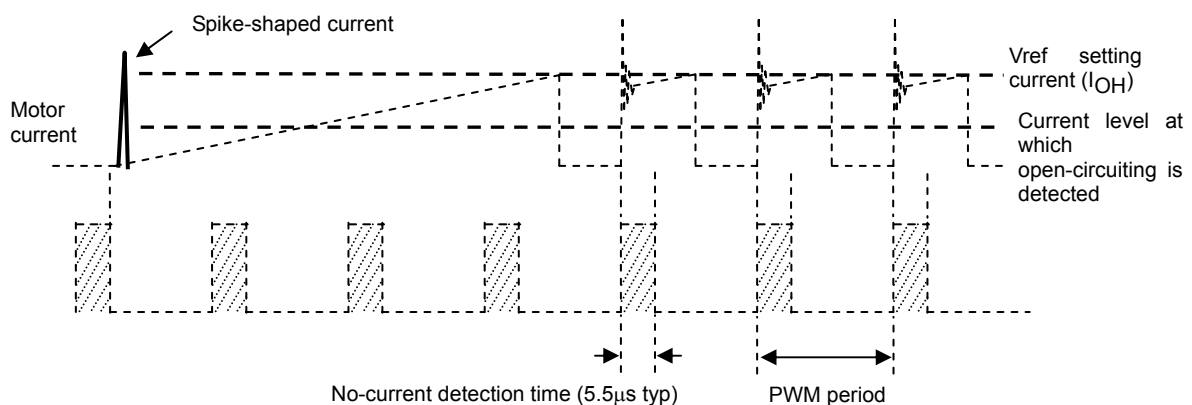

2-2. [Overcurrent detection]

This hybrid IC is equipped with a function for detecting overcurrent that arises when the motor burns out or when there is a short between the motor terminals.

Overcurrent detection occurs at 3.5A typ with the STK672-630CN-E, and 5.5A typ with the STK672-640CN-E.

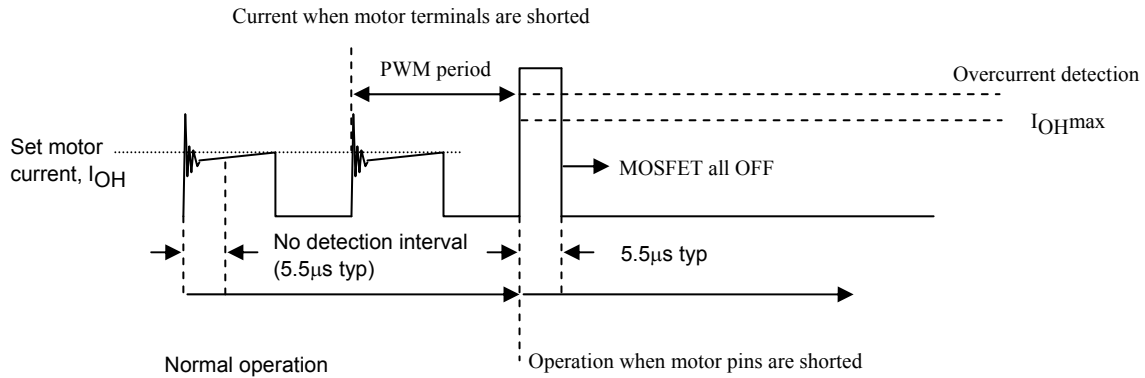

Overcurrent detection begins after an interval of no detection (a dead time of 5.5 μ s typ) during the initial ringing part during PWM operations. The no detection interval is a period of time where overcurrent is not detected even if the current exceeds I_{OH} .

2-3. [Overheat detection]

Rather than directly detecting the temperature of the semiconductor device, overheat detection detects the temperature of the aluminum substrate (144 $^{\circ}$ C typ).

Within the allowed operating range recommended in the specification manual, if a heat sink attached for the purpose of reducing the operating substrate temperature, T_c , comes loose, the semiconductor can operate without breaking.

However, we cannot guarantee operations without breaking in the case of operations other than those recommended, such as operations at a current exceeding I_{OHmax} that occurs before overcurrent detection is activated.

3. Allowable Avalanche Energy Value

(1) Allowable Range in Avalanche Mode

When driving a 2-phase Stepper motor with constant current chopping using an STK672-6** Series hybrid IC, the waveforms shown in Figure 1 below result for the output current, I_D , and voltage, V_{DS} .

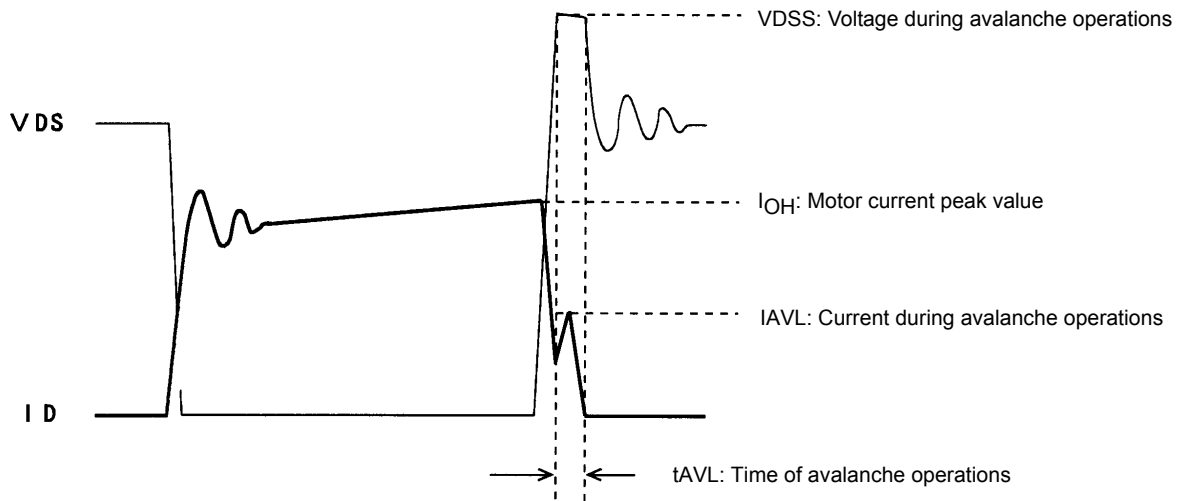

Figure 1 Output Current, I_D , and Voltage, V_{DS} , Waveforms 1 of the STK672-6** Series when Driving a 2-Phase Motor with Constant Current Chopping

When operations of the MOSFET built into STK672-6** Series ICs is turned off for constant current chopping, the I_D signal falls like the waveform shown in the figure above. At this time, the output voltage, V_{DS} , suddenly rises due to electromagnetic induction generated by the motor coil.

In the case of voltage that rises suddenly, voltage is restricted by the MOSFET V_{DSS} . Voltage restriction by V_{DSS} results in a MOSFET avalanche. During avalanche operations, I_D flows and the instantaneous energy at this time, E_{AVL1} , is represented by Equation (3-1).

$$E_{AVL1} = V_{DSS} \times I_{AVL} \times 0.5 \times t_{AVL} \text{ ----- (3-1)}$$

V_{DSS} : V units, I_{AVL} : A units, t_{AVL} : sec units

The coefficient 0.5 in Equation (3-1) is a constant required to convert the I_{AVL} triangle wave to a square wave.

During STK672-6** Series operations, the waveforms in the figure above repeat due to the constant current chopping operation. The allowable avalanche energy, E_{AVL} , is therefore represented by Equation (3-2) used to find the average power loss, P_{AVL} , during avalanche mode multiplied by the chopping frequency in Equation (3-1).

$$P_{AVL} = V_{DSS} \times I_{AVL} \times 0.5 \times t_{AVL} \times f_c \text{ ----- (3-2)}$$

f_c : Hz units (f_c is set to the PWM frequency of 50kHz.)

For V_{DSS} , I_{AVL} , and t_{AVL} , be sure to actually operate the STK672-6** Series and substitute values when operations are observed using an oscilloscope.

Ex. If $V_{DSS}=110V$, $I_{AVL}=1A$, $t_{AVL}=0.2\mu s$, the result is:
 $P_{AVL}=110 \times 1 \times 0.5 \times 0.2 \times 10^{-6} \times 50 \times 10^3 = 0.55W$
 $V_{DSS}=110V$ is a value actually measured using an oscilloscope.

The allowable loss range for the allowable avalanche energy value, P_{AVL} , is shown in the graph in Figure 3. When examining the avalanche energy, be sure to actually drive a motor and observe the I_D , V_{DSS} , and t_{AVL} waveforms during operation, and then check that the result of calculating Equation (3-2) falls within the allowable range for avalanche operations.

(2) I_D and V_{DS} Operating Waveforms in Non-avalanche Mode

Although the waveforms during avalanche mode are given in Figure 1, sometimes an avalanche does not result during actual operations.

Factors causing avalanche are listed below.

- Poor coupling of the motor's phase coils (electromagnetic coupling of A phase and AB phase, B phase and BB phase).
- Increase in the lead inductance of the harness caused by the circuit pattern of the board and motor.
- Increases in V_{DS} , t_{AVL} , and I_{AVL} in Figure 1 due to an increase in the supply voltage from 24V to 36V.

If the factors above are negligible, the waveforms shown in Figure 1 become waveforms without avalanche as shown in Figure 2.

Under operations shown in Figure 2, avalanche does not occur and there is no need to consider the allowable loss range of $PAVL$ shown in Figure 3.

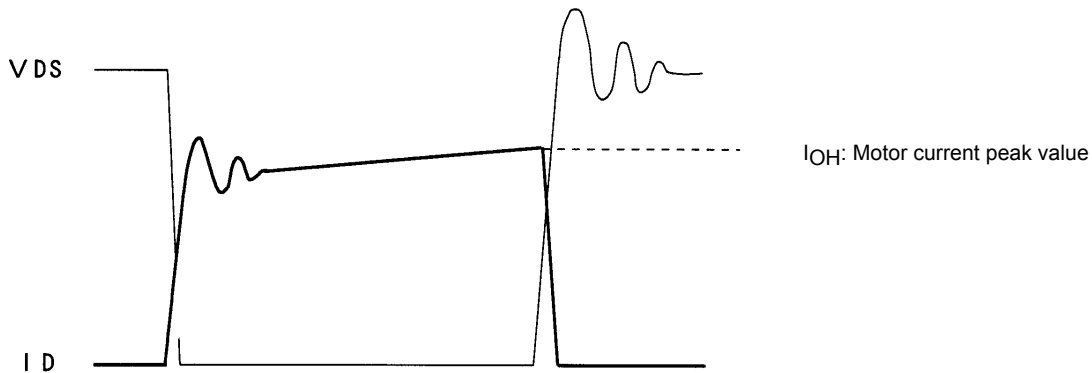
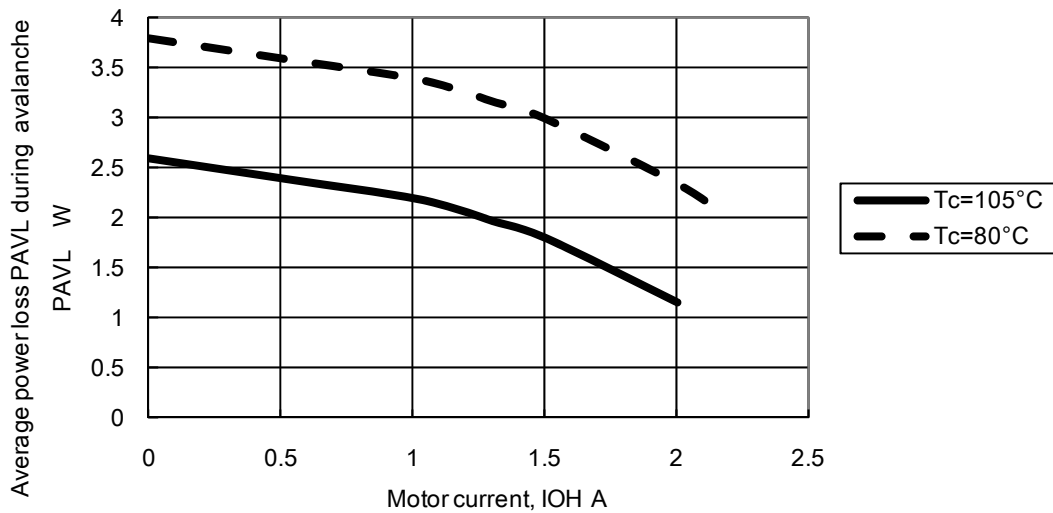

Figure 2 Output Current, I_D , and Voltage, V_{DS} , Waveforms 2 of the STK672-6** Series when Driving a 2-Phase Stepper Motor with Constant Current Chopping

Figure 3 Allowable Loss Range, $PAVL-I_{OH}$ During STK672-630CN-E Avalanche Operations
 $PAVL-I_{OH}$



Note :

The operating conditions given above represent a loss when driving a 2-phase stepper motor with constant current chopping.

Because it is possible to apply 2.6W or more at $I_{OH}=0A$, be sure to avoid using the MOSFET body diode that is used to drive the motor as a zener diode.

4. Calculating STK672-630CN-E HIC Internal Power Loss

The average internal power loss in each excitation mode of the STK672-630CN-E can be calculated from the following formulas. *1

Each excitation mode

2-phase excitation mode

$$2PdAVex=(V_{sat}+V_{df}) \times 0.5 \times \text{CLOCK} \times I_{OH} \times t_2 + 0.5 \times \text{CLOCK} \times I_{OH} \times (V_{sat} \times t_1 + V_{df} \times t_3)$$

1-2 Phase excitation mode

$$1-2PdAVex=(V_{sat}+V_{df}) \times 0.25 \times \text{CLOCK} \times I_{OH} \times t_2 + 0.25 \times \text{CLOCK} \times I_{OH} \times (V_{sat} \times t_1 + V_{df} \times t_3)$$

Motor hold mode

$$\text{HoldPdAVex} = (V_{sat} + V_{df}) \times I_{OH}$$

Vsat : Combined voltage represented by the Ron voltage drop+shunt resistor

Vdf : Combined voltage represented by the MOSFET body diode+shunt resistor *1

CLOCK: Input CLOCK (CLOCK pin signal frequency)

t1, t2, and t3 represent the waveforms shown in the figure below.

t1 : Time required for the winding current to reach the set current (IOH)

t2 : Time in the constant current control (PWM) region

t3 : Time from end of phase input signal until inverse current regeneration is complete

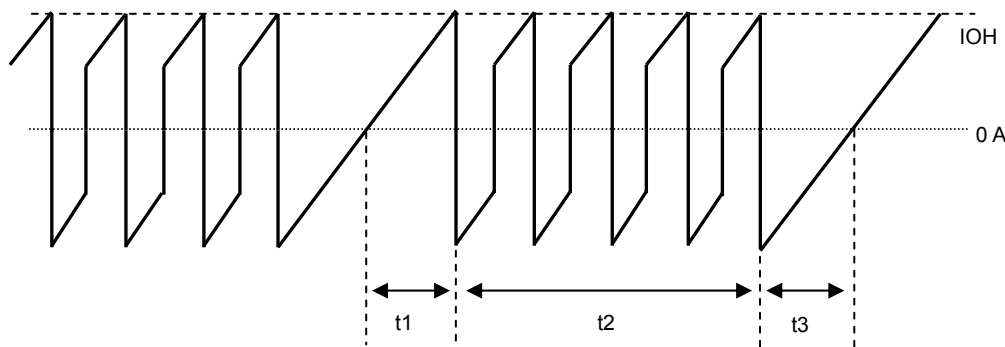

Motor COM Current Waveform Model

$$t1 = (-L / (R + 0.33)) \ln (1 - ((R + 0.33) / V_{CC}) \times I_{OH})$$

$$t3 = (-L / R) \ln ((V_{CC} + 0.33) / (I_{OH} \times R + V_{CC} + 0.33))$$

VCC : Motor supply voltage (V)

L : Motor inductance (H)

R : Motor winding resistance (Ω)

IOH : Motor set output current crest value (A)

Relationship of CLOCK, t1, t2, and t3 in each excitation mode

2-phase excitation mode : $t_2 = (2 / \text{CLOCK}) - (t_1 + t_3)$

1-2 phase excitation mode : $t_2 = (3 / \text{CLOCK}) - t_1$

For the values of Vsat and Vdf, be sure to substitute from Vsat vs IOH and Vdf vs IOH at the setting current value IOH. (See pages to follow)

Then, determine if a heat sink is necessary by comparing with the ΔTc vs Pd graph (see next page) based on the calculated average output loss, HIC.

For heat sink design, be sure to see ‘5. Thermal Design’.

The HIC average power, PdAVex described above, represents loss when not in avalanche mode.

To add the loss in avalanche mode, be sure to add PAVL using the formula (for average power loss , PAVL, for STK672-6** during avalanche mode, described below to PdAVex described above.)

When using this IC without a fin, always check for temperature increases in the set, because the HIC substrate temperature, Tc, varies due to effects of convection around the HIC.

STK672-630CN-E

4-2. [Calculating the average power loss, PAVL, during avalanche mode]

The allowable avalanche energy, EAVL, during fixed current chopping operation is represented by Equation (3-2) used to find the average power loss, PAVL, during avalanche mode that is calculated by multiplying Equation (3-1) by the chopping frequency.

$$\text{PAVL} = V_{\text{DSS}} \times \text{IAVL} \times 0.5 \times t_{\text{AVL}} \times f_c \dots\dots\dots (3-2)$$

f_c : Hz units (f_c is set to the PWM frequency of 50kHz.)

Be sure to actually operate an STK672-6** series and substitute values found when observing operations on an oscilloscope for V_{DSS} , IAVL, and tAVL.

The sum of PAVL values for each excitation mode is multiplied by the constants given below and added to the average internal HIC loss equation, except in the case of 2-phase excitation.

$$\text{1-2 excitation mode and higher: PAVL(1)} = 0.7 \times \text{PAVL} \dots\dots\dots (4-1)$$

$$\text{During 2-phase excitation mode and motor hold: PAVL(1)} = 1 \times \text{PAVL} \dots\dots\dots (4-2)$$

STK672-630CN-E

STK672-630CN-E Output Saturation Voltage V_{sat} vs. Output Current

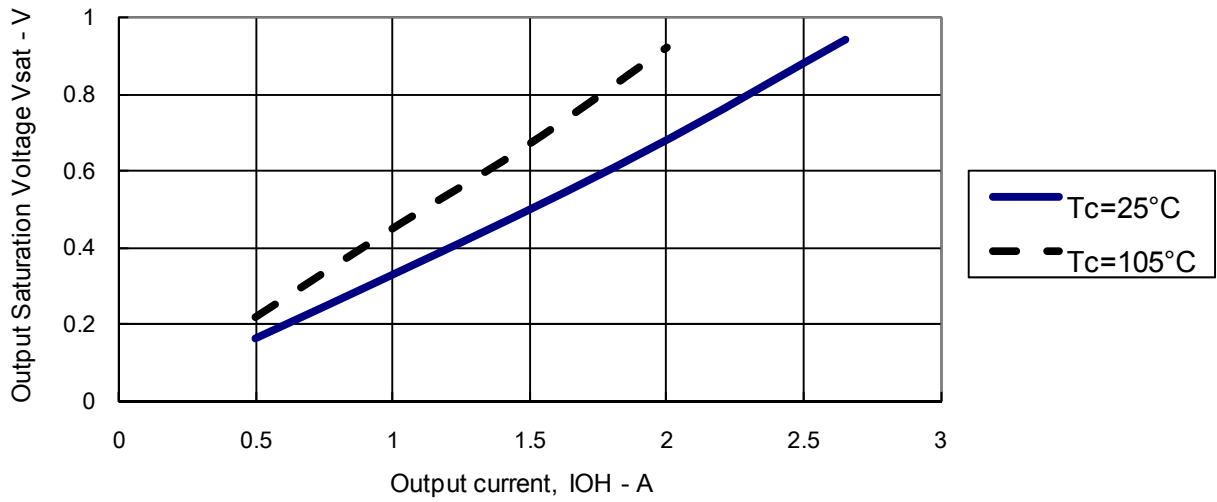

STK672-630CN-E Forward voltage, V_{df} - Output current, I_{OH}

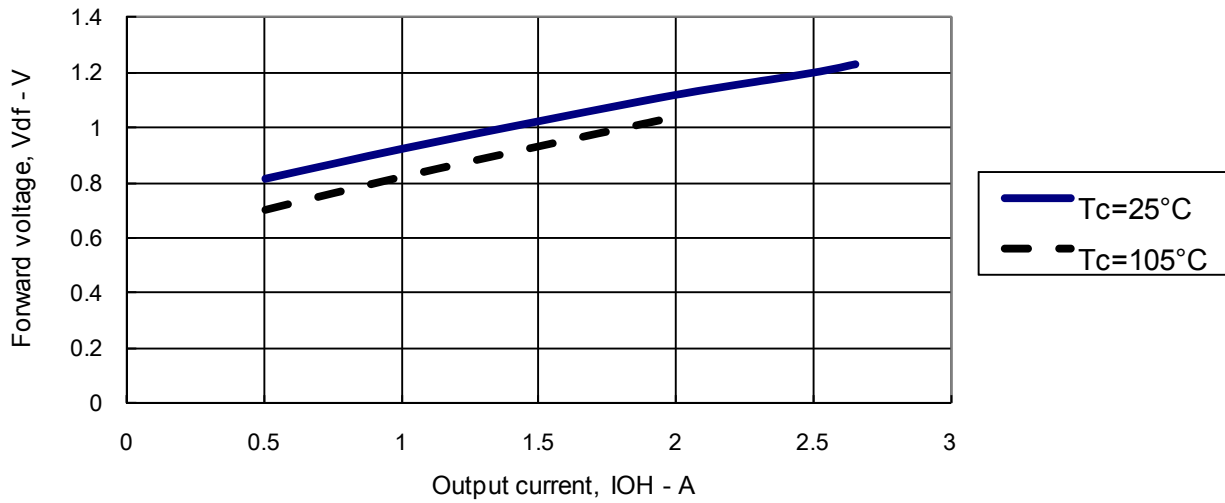

Substrate temperature rise, ΔT_c (no heat sink) - Internal average power dissipation, PdAV

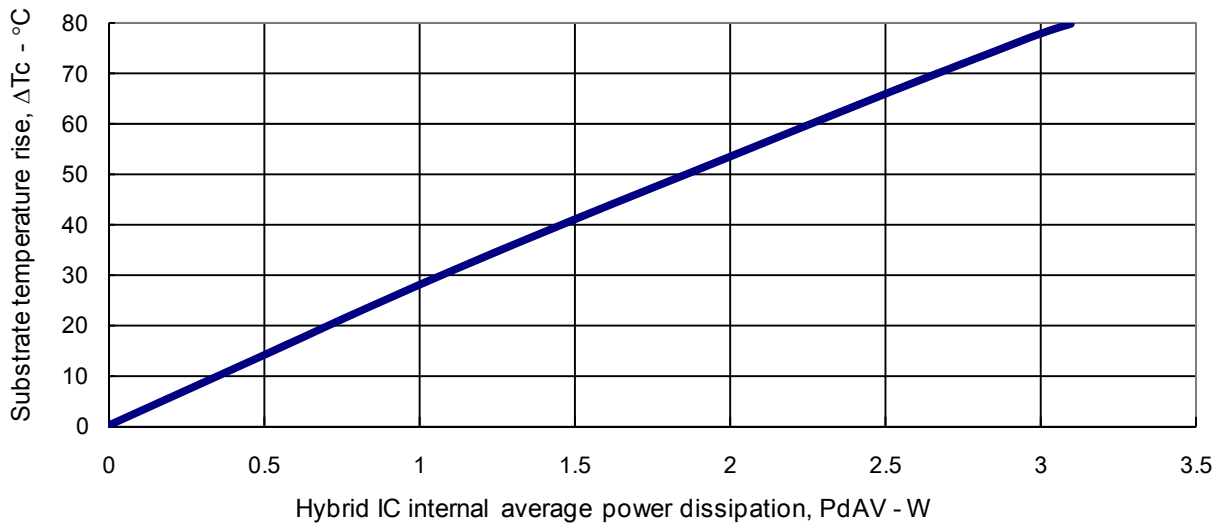

5. Thermal design

[Operating range in which a heat sink is not used]

Use of a heat sink to lower the operating substrate temperature of the HIC (Hybrid IC) is effective in increasing the quality of the HIC.

The size of heat sink for the HIC varies depending on the magnitude of the average power loss, PdAV, within the HIC. The value of PdAV increases as the output current increases. To calculate PdAV, refer to “Calculating Internal HIC Loss” in the specification document.

Calculate the internal HIC loss, PdAV, assuming repeat operation such as shown in Figure 1 below, since conduction during motor rotation and off time both exist during actual motor operations,

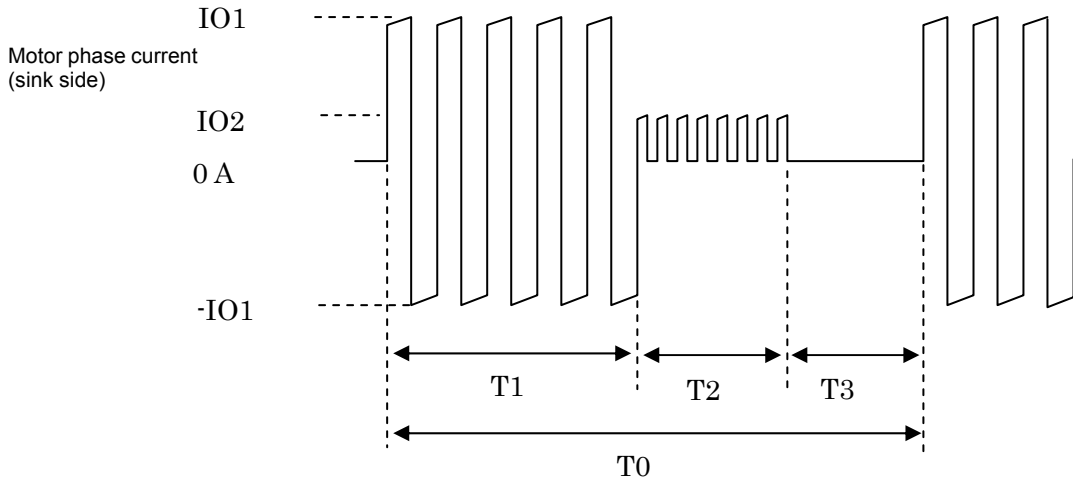

Figure 1 Motor Current Timing

T1 : Motor rotation operation time

T2 : Motor hold operation time

T3 : Motor current off time

T2 may be reduced, depending on the application.

T0 : Single repeated motor operating cycle

IO1 and IO2 : Motor current peak values

Due to the structure of motor windings, the phase current is a positive and negative current with a pulse form.

Note that figure 1 presents the concepts here, and that the on/off duty of the actual signals will differ.

The hybrid IC internal average power dissipation PdAV can be calculated from the following formula.

$$PdAV = (T1 \times P1 + T2 \times P2 + T3 \times 0) \div T0 \text{ ----- (I)}$$

(Here, P1 is the PdAV for IO1 and P2 is the PdAV for IO2)

If the value calculated using Equation (I) is 1.5W or less, and the ambient temperature, Ta, is 60°C or less, there is no need to attach a heat sink. Refer to Figure 2 for operating substrate temperature data when no heat sink is used.

[Operating range in which a heat sink is used]

Although a heat sink is attached to lower Tc if PdAV increases, the resulting size can be found using the value of θc-a in Equation (II) below and the graph depicted in Figure 3.

$$\theta_{c-a} = (Tc \text{ max} - Ta) \div PdAV \text{ ----- (II)}$$

Tc max : Maximum operating substrate temperature = 105°C

Ta: HIC ambient temperature

Although a heat sink can be designed based on equations (I) and (II) above, be sure to mount the HIC in a set and confirm that the substrate temperature, Tc, is 105°C or less.

The average HIC power loss, PdAV, described above represents the power loss when there is no avalanche operation. To add the loss during avalanche operations, be sure to add Equation (3-2), “Allowable STK672-6** Avalanche Energy Value”, to PdAV.

Figure 2

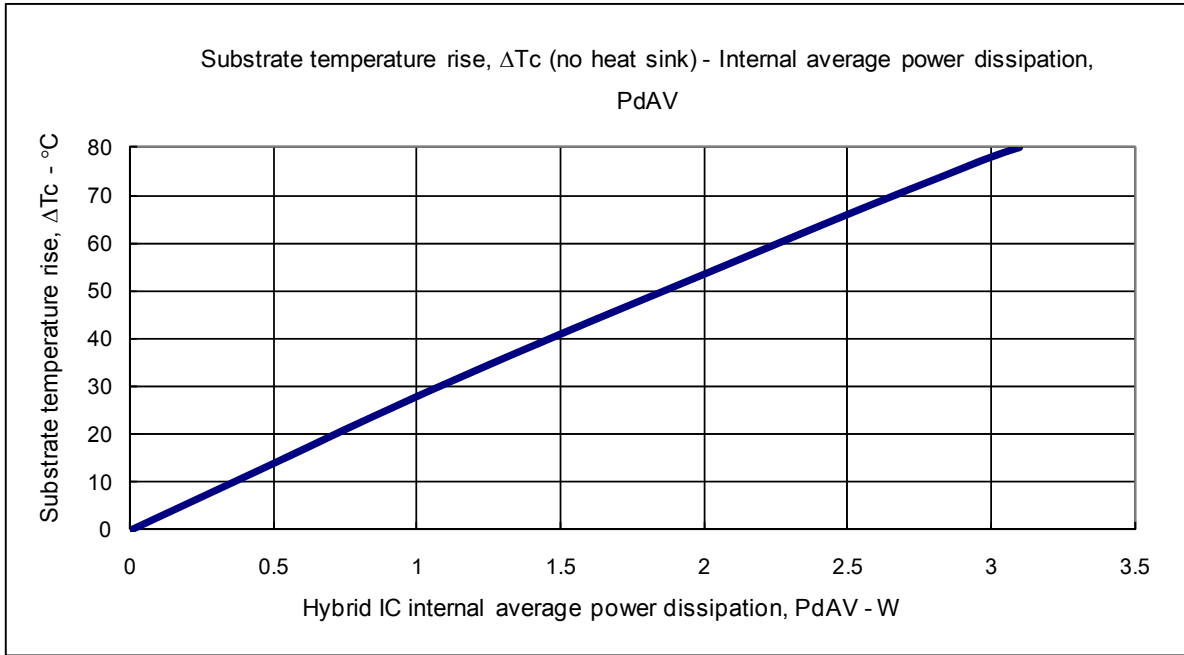
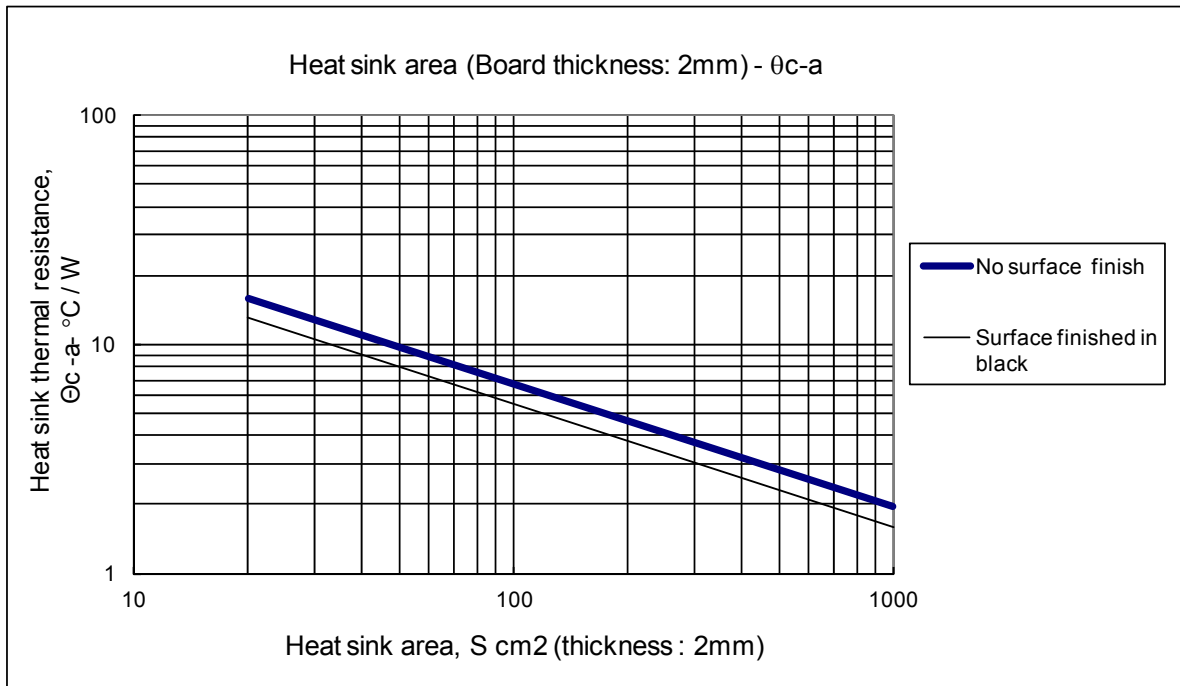

Figure 3



STK672-630CN-E

6. Mitigated Curve of Package Power Loss, PdPK, vs. Ambient Temperature, Ta

Package power loss, PdPK, refers to the average internal power loss, PdAV, allowable without a heat sink. The figure below represents the allowable power loss, PdPK, vs. fluctuations in the ambient temperature, Ta. Power loss of up to 3.1W is allowable at Ta=25°C, and of up to 1.75W at Ta=60°C.

* The package thermal resistance θ_{c-a} is 25.8°C/W.

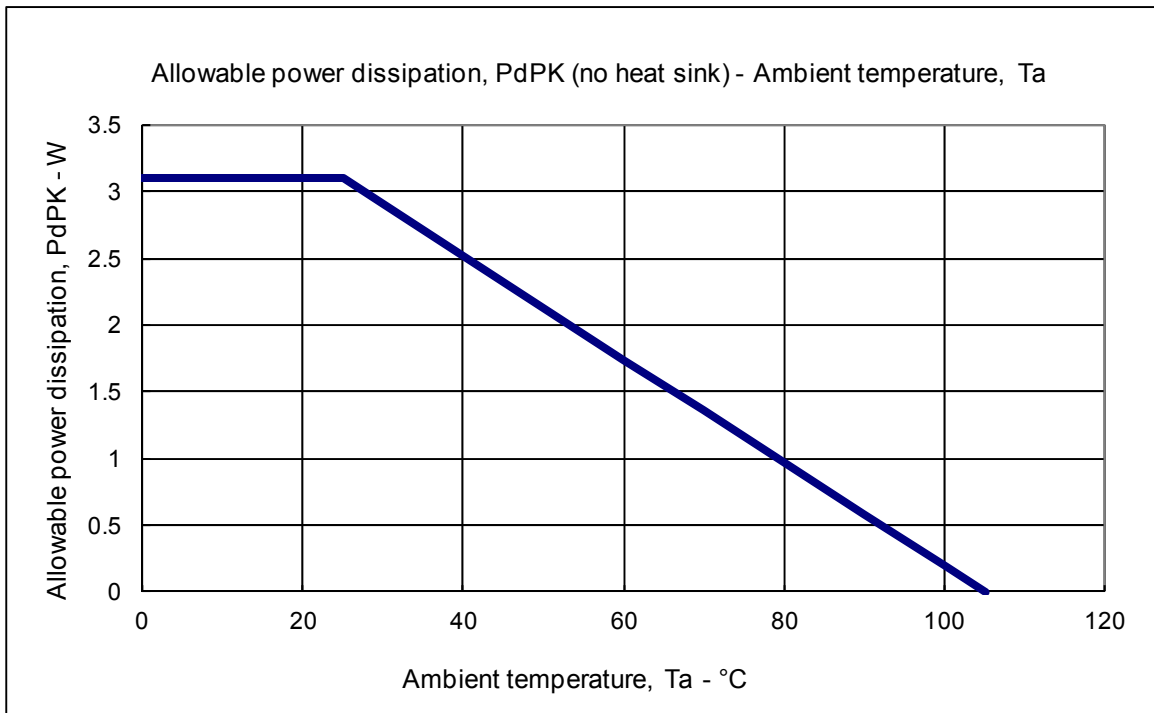

7. Example of Stepper Motor Driver Output Current Path (1-2 phase excitation)

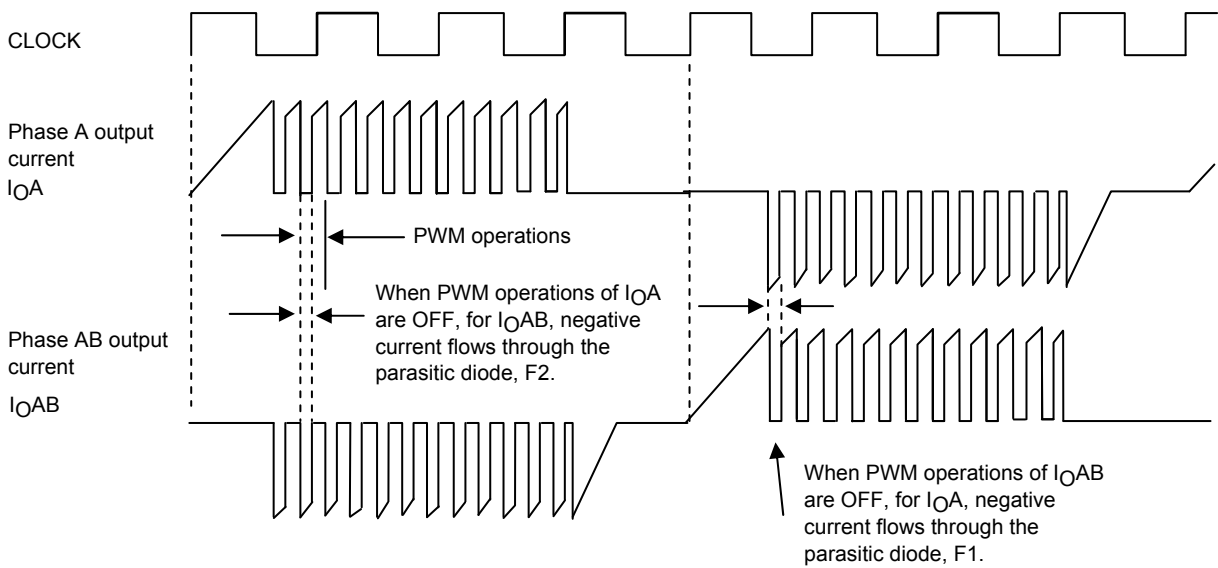
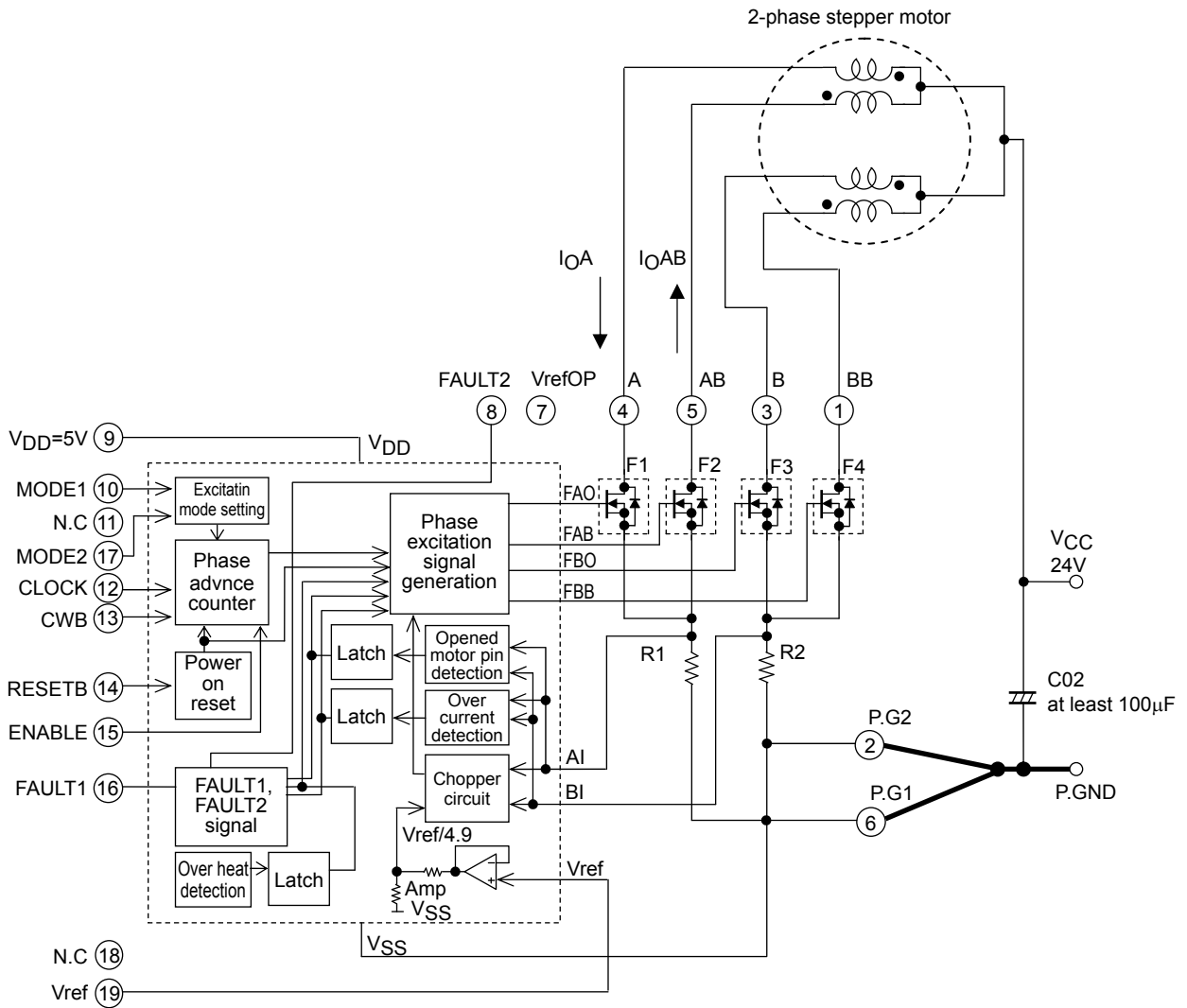

8. Other usage notes

In addition to the “Notes” indicated in the Sample Application Circuit, care should also be given to the following contents during use.

(1) Allowable operating range

Operation of this product assumes use within the allowable operating range. If a supply voltage or an input voltage outside the allowable operating range is applied, an overvoltage may damage the internal control IC or the MOSFET.

If a voltage application mode that exceeds the allowable operating range is anticipated, connect a fuse or take other measures to cut off power supply to the product.

(2) Input pins

If the input pins are connected directly to the board connectors, electrostatic discharge or other overvoltage outside the specified range may be applied from the connectors and may damage the product. Current generated by this overvoltage can be suppressed to effectively prevent damage by inserting 100Ω to 1kΩ resistors in lines connected to the input pins.

Take measures such as inserting resistors in lines connected to the input pins.

(3) Power connectors

If the motor power supply V_{CC} is applied by mistake without connecting the GND part of the power connector when the product is operated, such as for test purposes, an overcurrent flows through the V_{CC} decoupling capacitor, C1, to the parasitic diode between the V_{DD} of the internal control IC and GND, and may damage the power supply pin block of the internal control IC.

To prevent damage in this case, connect a 10Ω resistor to the V_{DD} pin, or insert a diode between the V_{CC} decoupling capacitor C1 GND and the V_{DD} pin.

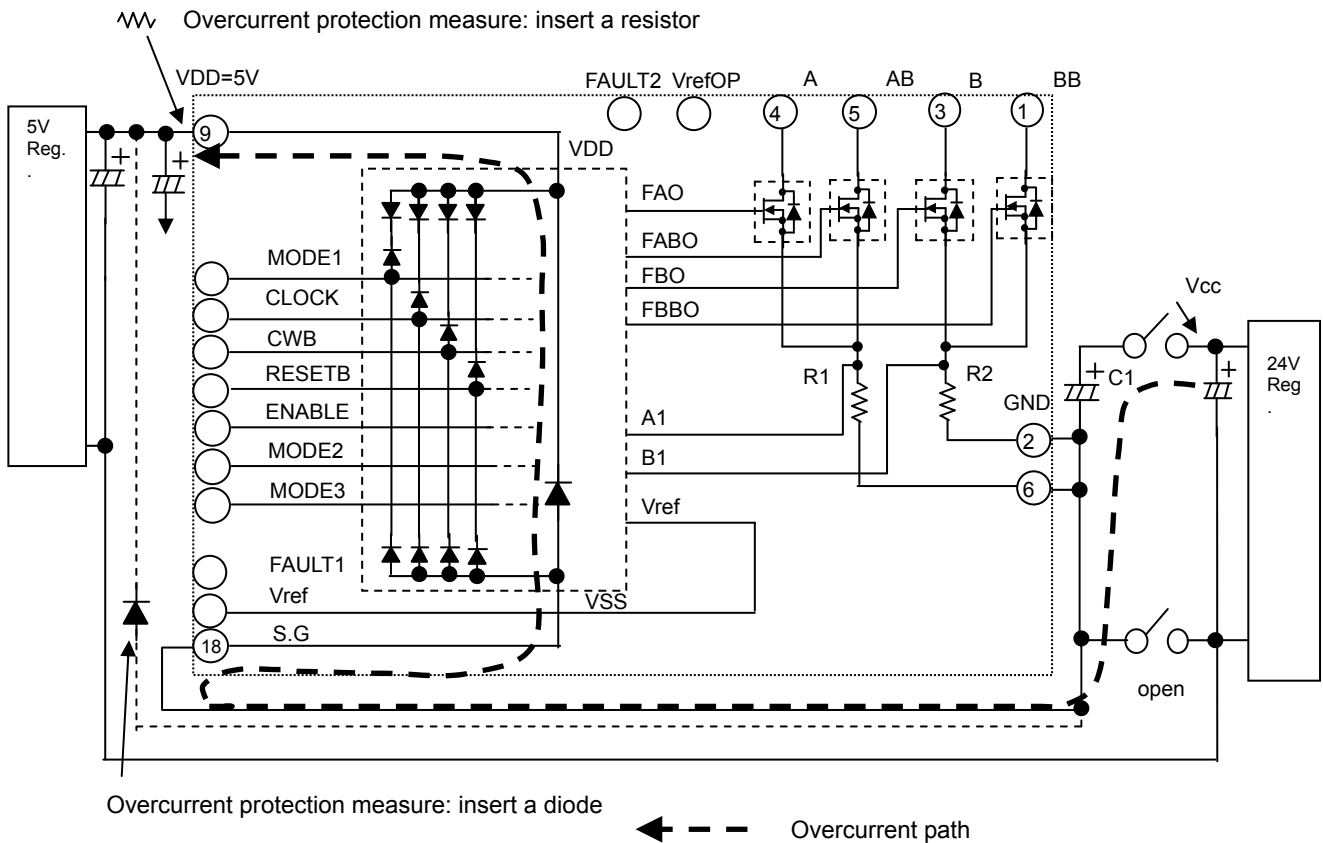

(4) Input Signal Lines

- 1) Do not use an IC socket to mount the driver, and instead solder the driver directly to the board to minimize fluctuations in the GND potential due to the influence of the resistance component and inductance component of the GND pattern wiring.
- 2) To reduce noise caused by electromagnetic induction to small signal lines, do not design small signal lines (sensor signal lines, and 5V or 3.3V power supply signal lines) that run parallel in close proximity to the motor output line A (Pin 4), AB (Pin 5), B (Pin 3), or BB (Pin 1) phases.

(5) When mounting multiple drivers on a single board

When mounting multiple drivers on a single board, the GND design should mount a V_{CC} decoupling capacitor, C1, for each driver to stabilize the GND potential of the other drivers. The key wiring points are as follows.

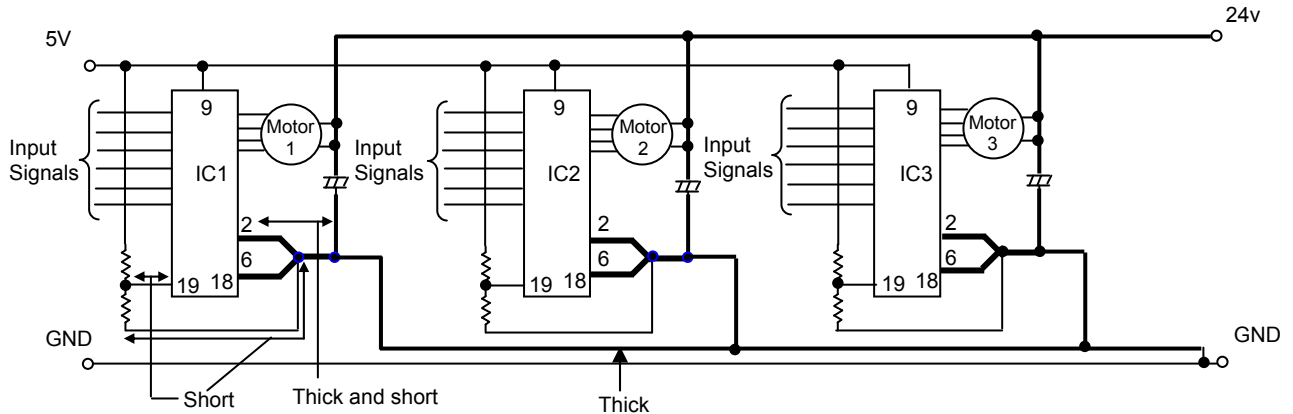

(6) V_{CC} operating limit

When the output (for example F1) of a 2-phase stepper motor driver is turned OFF, the AB phase back electromotive force e_{ab} produced by current flowing to the paired F2 parasitic diode is induced in the F1 side, causing the output voltage V_{FB} to become twice or more the V_{CC} voltage. This is expressed by the following formula.

$$V_{FB} = V_{CC} + e_{ab}$$

$$= V_{CC} + V_{CC} + I_{OH} \times R_M + V_{df} (1.6V)$$

V_{CC} : Motor supply voltage, I_{OH} : Motor current set by V_{ref}

V_{df} : Voltage drop due to F2 parasitic diode and current detection resistor R1, R_M : Motor winding resistance value

Using the above formula, make sure that V_{FB} is always less than the MOSFET withstand voltage of 100V. This is because there is a possibility that operating limit of V_{CC} falls below the allowable operating range of 46V, due to the R_M and I_{OH} specifications.

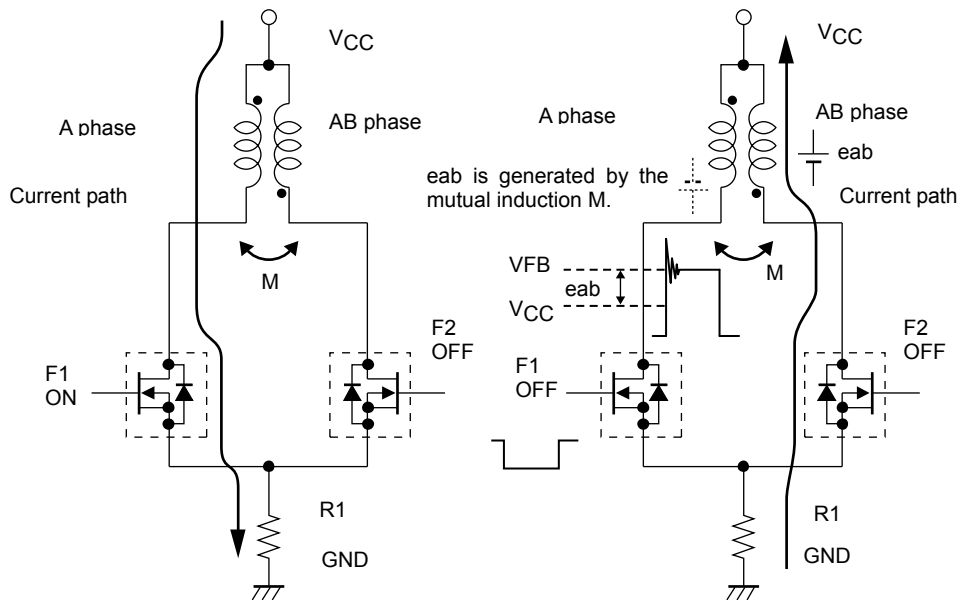

The oscillating voltage in excess of V_{FB} is caused by LCRM (inductance, capacitor, resistor, mutual inductance) oscillation that includes micro capacitors C , not present in the circuit. Since M is affected by the motor characteristics, there is some difference in oscillating voltage according to the motor specifications. In addition, constant voltage drive without constant current drive enables motor rotation at $V_{CC} \geq 0V$.

ORDERING INFORMATION

Device	Package	Shipping (Qty / Packing)
STK672-630CN-E	SIP-19 (Pb-Free)	15 / Tube

ON Semiconductor and the ON logo are registered trademarks of Semiconductor Components Industries, LLC (SCILLC). SCILLC owns the rights to a number of patents, trademarks, copyrights, trade secrets, and other intellectual property. A listing of SCILLC's product/patent coverage may be accessed at www.onsemi.com/site/pdf/Patent-Marking.pdf. SCILLC reserves the right to make changes without further notice to any products herein. SCILLC makes no warranty, representation or guarantee regarding the suitability of its products for any particular purpose, nor does SCILLC assume any liability arising out of the application or use of any product or circuit, and specifically disclaims any and all liability, including without limitation special, consequential or incidental damages. "Typical" parameters which may be provided in SCILLC data sheets and/or specifications can and do vary in different applications and actual performance may vary over time. All operating parameters, including "Typicals" must be validated for each customer application by customer's technical experts. SCILLC does not convey any license under its patent rights nor the rights of others. SCILLC products are not designed, intended, or authorized for use as components in systems intended for surgical implant into the body, or other applications intended to support or sustain life, or for any other application in which the failure of the SCILLC product could create a situation where personal injury or death may occur. Should Buyer purchase or use SCILLC products for any such unintended or unauthorized application, Buyer shall indemnify and hold SCILLC and its officers, employees, subsidiaries, affiliates, and distributors harmless against all claims, costs, damages, and expenses, and reasonable attorney fees arising out of, directly or indirectly, any claim of personal injury or death associated with such unintended or unauthorized use, even if such claim alleges that SCILLC was negligent regarding the design or manufacture of the part. SCILLC is an Equal Opportunity/Affirmative Action Employer. This literature is subject to all applicable copyright laws and is not for resale in any manner.



Стандарт Электрон Связь

Мы молодая и активно развивающаяся компания в области поставок электронных компонентов. Мы поставляем электронные компоненты отечественного и импортного производства напрямую от производителей и с крупнейших складов мира.

Благодаря сотрудничеству с мировыми поставщиками мы осуществляем комплексные и плановые поставки широчайшего спектра электронных компонентов.

Собственная эффективная логистика и склад в обеспечивает надежную поставку продукции в точно указанные сроки по всей России.

Мы осуществляем техническую поддержку нашим клиентам и предпродажную проверку качества продукции. На все поставляемые продукты мы предоставляем гарантию .

Осуществляем поставки продукции под контролем ВП МО РФ на предприятия военно-промышленного комплекса России , а также работаем в рамках 275 ФЗ с открытием отдельных счетов в уполномоченном банке. Система менеджмента качества компании соответствует требованиям ГОСТ ISO 9001.

Минимальные сроки поставки, гибкие цены, неограниченный ассортимент и индивидуальный подход к клиентам являются основой для выстраивания долгосрочного и эффективного сотрудничества с предприятиями радиоэлектронной промышленности, предприятиями ВПК и научно-исследовательскими институтами России.

С нами вы становитесь еще успешнее!

Наши контакты:

Телефон: +7 812 627 14 35

Электронная почта: sales@st-electron.ru

Адрес: 198099, Санкт-Петербург,
Промышленная ул, дом № 19, литера Н,
помещение 100-Н Офис 331