

ZCU102 Evaluation Board

User Guide

UG1182 (v1.6) June 12, 2019



Revision History

The following table shows the revision history for this document.

Date	Version	Revision
06/12/2019	1.6	Chapter 3, Board Component Descriptions . Replaced Table 3-7 . Updated HDMI Video Output in Chapter 3 . Updated Figure 3-23 . Updated Table 3-30 for pin B1. Added HDMI Video Input section. Enhanced Figure A-1 .
01/11/2019	1.5	Changed DDR4 72-bit to DDR4 64-bit in Figure 1-1 and PS-Side: DDR4 SODIMM Socket in Chapter 3 . Removed ECC from Board Features . Updated Table 2-1 , callout 2, with DDR4 SODIMM and updated the Micron part number (MTA4ATF51264HZ-2G6E1). Updated Markings .
10/04/2018	1.4	<ul style="list-style-type: none"> Updated Figure 2-1 and Figure 2-2. Added Electrostatic Discharge Caution in Chapter 2. Updated schematic number in Table 2-1. Updated SFP0-SFP3 functions in Table 2-3. Updated callout in Cooling Fan Connector in Chapter 3. Updated descriptions in PS-Side: DDR4 SODIMM Socket and PL-Side: DDR4 Component Memory in Chapter 3. Updated Ports 0 and 4 I2C address in Table 3-23. Added Note in SFP/SFP+ Connector in Chapter 3. Updated Bank info in SFP+ in Chapter 3. Updated I/O Standard for AE5 and AF5 in Table 3-52. Updated Appendix B, Xilinx Design Constraints. Updated Appendix C, Regulatory and Compliance Information. Updated XTP433 and XTP435 links and added DS925 and ZCU102 Design Hub link in Appendix D, Additional Resources and Legal Notices.
08/02/2017	1.3	Updated logic cell and CLB flip-flop resource count in Table 1-1 . Added Note 2 to Table 2-2 . Changed maximum PL internal supply voltage from 0.875V to 0.876V in Table 3-1 . Updated GTR_REF_CLK_USB3 frequency in Table 3-12 . Added I2C addresses to Table 3-23 and Table 3-24 . Clarified third paragraph under HDMI Clock Recovery in Chapter 3 .
03/20/2017	1.2	Added notes to Dimensions in Chapter 1 . Updated SW6 default switch setting in Table 2-2 and SD configuration setting in Table 2-4 . Clarified SW6[4:1] boot mode pin settings under Quad-SPI and SD in Chapter 2 . Changed "DDR SODIMM Memory J1" heading to "DDR Component Memory" in Table 3-4 . Changed PS_REF_CLK frequency from 33 MHz to 33.33 MHz in Table 3-12 . Changed "UART2_RTS_O_B" to "UART2_CTS_O_B" in Table 3-16 . Replaced Figure 3-16 . Changed "QSPI119 (LWR), U120 (UPR)" heading to "MSP430 U41" in Figure 3-17 . Clarified references to Figure 3-17 in Table 3-19 and Table 3-20 . Added addresses to titles in Table 3-21 and Table 3-22 and headings in Table 3-23 and Table 3-24 . Changed "22" to "L22" in Table 3-28 . Updated GTH connectivity for Quad 128, Quad 228, Quad 229, and Quad 23 under GTH Transceivers in Chapter 3 . Updated bank assignments in Figure 3-36 . Added callout 44 to Switches in Chapter 3 . Updated Xilinx websites in Appendix D, Additional Resources and Legal Notices .

Date	Version	Revision
11/16/2016	1.1	Updated device part number from XCZU9EG-2FFVB1156 to XCZU9EG-2FFVB1156I throughout document. Updated board photos (Figure 2-1 and Figure 2-2) to rev 1.0. Updated Table 2-1 and Table 2-3 . Updated Component Descriptions in Chapter 3 . Updated Appendix B, Xilinx Design Constraints .
05/11/2016	1.0	Initial Xilinx release - limited distribution.

Table of Contents

Revision History	2
Chapter 1: Introduction	
Overview	7
Block Diagram	8
Board Features	9
Board Specifications	11
Dimensions	11
Environmental	11
Operating Voltage	11
Chapter 2: Board Setup and Configuration	
Board Component Location	12
Electrostatic Discharge Caution	12
Default Switch and Jumper Settings	16
Switches	18
Jumpers	18
MPSoC Device Configuration	21
Chapter 3: Board Component Descriptions	
Overview	22
Component Descriptions	22
Zynq UltraScale XCZU9EG MPSoC	22
PS-Side: DDR4 SODIMM Socket	27
PL-Side: DDR4 Component Memory	31
PSMIO	34
Quad-SPI Flash Memory (MIO 0–12)	34
USB 3.0 Transceiver and USB 2.0 ULPI PHY	36
SD Card Interface	40
Programmable Logic JTAG Programming Options	42
EMIO Arm Trace Port	44
Clock Generation	46
GEM3 Ethernet (MIO 64-77)	51
10/100/1000 MHz Tri-Speed Ethernet PHY	52
CP2108 USB UART Interface	54
GPIO (MIO 13, 38)	57
I2C0 (MIO 14-15)	57
I2C1 (MIO 16-17)	62

UART0 (MIO 18-19)	63
UART1 (MIO 20-21)	64
GPIO (MIO 22-23)	64
CAN1 (MIO 24-25)	65
PMU GPI (MIO 26)	65
DPAUX (MIO 27-30)	66
PCIe Reset (MIO 31)	67
PMU GPO (MIO 32-37)	68
HDMI Video Output	68
HDMI Video Input	69
HDMI Clock Recovery	72
SFP/SFP+ Connector	73
SFP/SFP+ Clock Recovery	75
User PMOD GPIO Headers	76
Prototype Header	78
User I2C0 Receptacle	79
User I/O	79
Power and Status LEDs	82
GTH Transceivers	84
PS-Side: GTR Transceivers	93
PCIe (MIO 31)	96
PCI Express Root Port Slot	96
FPGA Mezzanine Card Interface	97
FMC HPC0 Connector J5	97
FMC HPC1 Connector J4	102
Cooling Fan Connector	108
VADJ_FMC Power Rail	108
TI MSP430 System Controller	109
Switches	111
ZCU102 Board Power System	114
Monitoring Voltage and Current	116

Appendix A: VITA 57.1 FMC Connector Pinouts

Overview	118
----------------	-----

Appendix B: Xilinx Design Constraints

Overview	119
----------------	-----

Appendix C: Regulatory and Compliance Information

Overview	120
CE Directives	120
CE Standards	120
Electromagnetic Compatibility	120
Safety	121
Markings	121

Appendix D: Additional Resources and Legal Notices

Xilinx Resources	122
------------------------	-----

Solution Centers	122
Documentation Navigator and Design Hubs	122
References	123
Please Read: Important Legal Notices	124

Introduction

Overview

The ZCU102 is a general purpose evaluation board for rapid-prototyping based on the Zynq[®] UltraScale+[™] XCZU9EG-2FFVB1156E MPSoC (multiprocessor system-on-chip). High speed DDR4 SODIMM and component memory interfaces, FMC expansion ports, multi-gigabit per second serial transceivers, a variety of peripheral interfaces, and FPGA logic for user customized designs provides a flexible prototyping platform.

Block Diagram

The ZCU102 board block diagram is shown in [Figure 1-1](#). Page numbers in the block diagram reference the corresponding page number(s) of schematic 0381701.

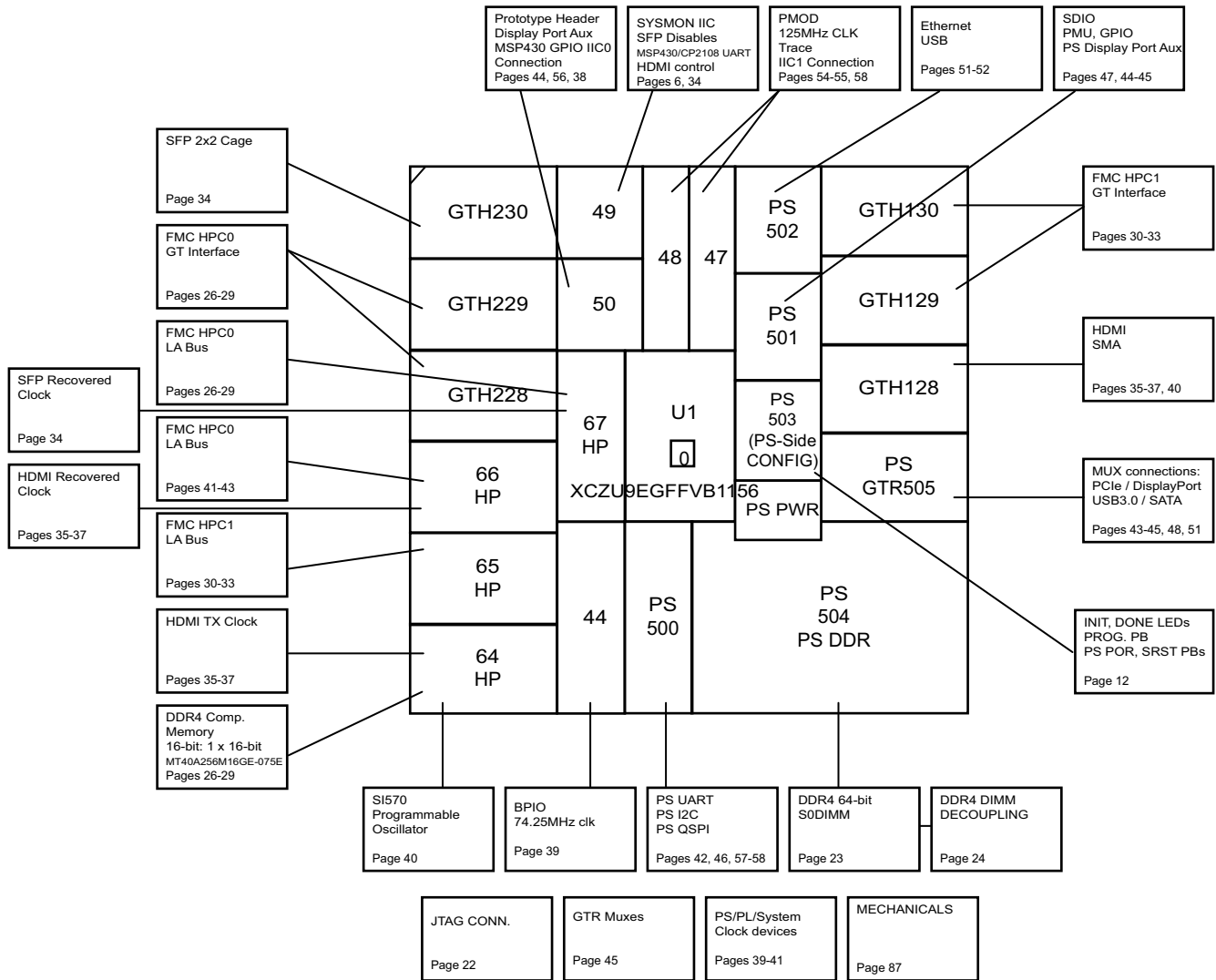

X16522-122118

Figure 1-1: ZCU102 Evaluation Board Block Diagram

Board Features

The ZCU102 evaluation board features are listed here. Detailed information for each feature is provided in [Chapter 3, Board Component Descriptions](#).

- XCZU9EG-2FFVB1156E MPSoC
- PL V_{CCINT} for range in datasheet
- Form factor for PCIe Gen2x4 Host, Micro-ATX chassis footprint
- Configuration from QSPI
- Configuration from SD card
- Configuration over JTAG with PC4 header
- Configuration over JTAG with Arm 20-pin header
- Configuration over USB-to-JTAG Bridge
- Clocks (PL-system, PS_CLK, Programmable Clock, SMA, SMA_GT_REF, Ethernet, USB)
- PS DDR4 64-bit SODIMM
- PL DDR4 component (16-bit)
- PS GTR assignment
 - SATA
 - DisplayPort
 - USB3
 - PCIe Gen2x4 Root Port
- PL GTH assignment
 - FMC #1 (8 GTH) and FMC #2 (8 GTH) PL GT assignment
 - High-Definition Multimedia Interface (HDMI™) technology (3 GTH) PL GT assignment
 - SFP+ (4 GTH) PL GT assignment
 - SMA (1 GTH) PL GT assignment
- PL FMC HPC #1 Connectivity - Full LA Bus
- PL FMC HPC #2 Connectivity - Partial LA Bus
- PS MIO: QSPI
- PS MIO: Ethernet
- PS MIO: USB2 (same connector as USB3)

- PS MIO: SD
- PS MIO: CAN
- PS MIO: UART (using USB-to-UART bridge)
- PS MIO: second UART
- PS MIO: I2C shared across PS and PL
- PS/PL EMIO: Trace
- PL-side UART
- PL-side LEDs (8)
- PL-side DIP switch (8-position)
- PL-side pushbuttons (5)
- PS-side pushbutton (1)
- PS-side LED (1)
- System user switches (PROG, CPU Reset)
- PJTAG
- Security - PSBATT button battery backup
- SYSMON
- Operational switches (Power on/off, PROG, Boot mode)
- Operational status LEDs (power supply status, INIT, DONE, PG, JTAG status, DDR power good)
- Power Management

The ZCU102 evaluation board provides designers a rapid prototyping platform using the XCZU9EG-2FFVB1156E device. The ZU9EG contains many useful processor system (PS) hard block peripherals exposed through the Multi-use I/O (MIO) interface and a variety of FPGA programmable logic (PL), high-density (HD) and high-performance (HP) banks. [Table 1-1](#) lists a brief summary of the resources available within the ZU9EG. A feature set overview, description, and ordering information is provided in the *Zynq UltraScale+ MPSoC Data Sheet: Overview* (DS891) [[Ref 1](#)].

Table 1-1: Zynq UltraScale+ MPSoC ZCU9EG Features and Resources

Feature	Resource Count
HD banks	5 banks, total of 120 pins
HP banks	4 banks, total of 208 pins
MIO banks	3 banks, total of 78 pins
PS-side GTR 6 Gb/s transceivers	4 PS-GTRs

Table 1-1: Zynq UltraScale+ MPSoC ZCU9EG Features and Resources (Cont'd)

Feature	Resource Count
PL-side GTH 16.3 Gb/s transceivers	24 GTHs
Logic cells	599,550
CLB flip-flops	548,160
Max. distributed RAM	8.8 Mb
Total block RAM	32.1 Mb
DSP slices	2,520

Board Specifications

Dimensions

Width: 9.350 in. (23.749 cm)

Length: 9.600 in. (24.384 cm)

Thickness: 0.104 in. (0.2642 cm)

Notes:

- A 3D model of this board is not available.
- ZCU102 board documentation (xdc listing, schematics, layout files and board outline/fab drawings, etc.) is available on the web at www.xilinx.com/zcu102.

Environmental

Temperature

Operating: 0°C to +45°C

Storage: -25°C to +60°C

Humidity

10% to 90% non-condensing

Operating Voltage

+12 V_{DC}

Board Setup and Configuration

Board Component Location

Figure 2-1 shows the ZCU102 board component locations. Each numbered component shown in Figure 2-1 is keyed to Table 2-1. Table 2-1 identifies the components, references the respective schematic page numbers, and links to a detailed functional description of the components and board features in Chapter 3.



IMPORTANT: *Figure 2-1 is for visual reference only and might not reflect the latest revision of the board. (This user guide documents ZCU102 Rev. 1.0 and later.)*



IMPORTANT: *There could be multiple revisions of this board. The specific details concerning the differences between revisions is not captured in this document. This document is not intended to be a reference design guide and the information herein should not be used as such. Always refer to the schematic and xdc of the specific ZCU102 version of interest for such details.*

Electrostatic Discharge Caution



CAUTION! *ESD can damage electronic components when they are improperly handled, and can result in total or intermittent failures. Always follow ESD-prevention procedures when removing and replacing components.*

To prevent ESD damage:

- Use an ESD wrist or ankle strap and ensure that it makes skin contact. Connect the equipment end of the strap to an unpainted metal surface on the chassis.
- Avoid touching the adapter against your clothing. The wrist strap protects components from ESD on the body only.
- Handle the adapter by its bracket or edges only. Avoid touching the printed circuit board or the connectors.
- Put the adapter down only on an antistatic surface such as the bag supplied in your kit.

- If you are returning the adapter to Xilinx Product Support, place it back in its antistatic bag immediately.

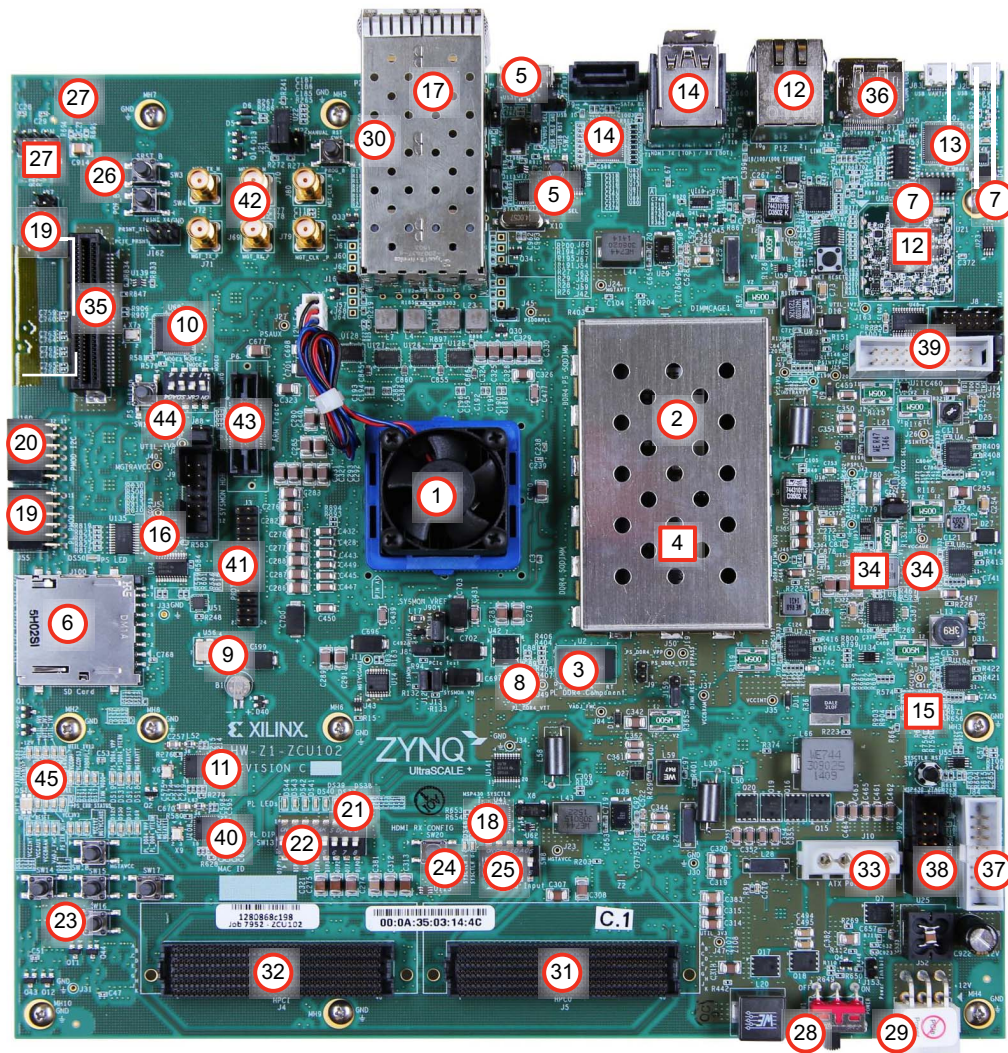

00 Round callout references a component On the front side of the board

00 Square callout references a component On the back side of the board

X16618-091718

Figure 2-1: ZCU102 Evaluation Board Components

Table 2-1: ZCU102 Board Components

Callout	Ref. Des.	Feature/Component	Notes	Schematic 0381701 Page Number
1	U1	Zynq UltraScale XCZU9EG MPSoC with fan sink on soldered FPGA	XCZU9EG-2FFVB1156E Radian FA35+K52B+T710	
2	J1	PS-Side: DDR4 SODIMM Socket with DDR4 SODIMM	OTES ADDR0067-P001A Micron MTA4ATF51264HZ-2G6E1	23
3	U2	PL-Side: DDR4 Component Memory, (4 Gb)	Micron MT40A256M16GE-075E:B	25
4	U119, U120	Quad-SPI Flash Memory (MIO 0–12) (1 Gb total)	Micron MT25QU512ABB8ESF-OSIT	46
5	U116, J96	USB 3.0 Transceiver and USB 2.0 ULPI PHY (USB micro-AB connector)	SMCS USB3320-EZK, KYON KMMX-AB10-SMT1SB30TR	51
6	J100	SD Card Interface (connector)	Hirose DMIAA-SF-PET(21)	47
7	U21/J2	Programmable Logic JTAG Programming Options (module with separate USB Micro-B conn.)	Digilent JTAG_2_NC, Hirose ZX62D-AB-5P8	22
8	U42	Programmable User Clock (300 MHz default, 3.3V LVDS)	Silicon Labs SI570BAB001614DG	40
9	U56	Programmable User MGT Clock (156.250 MHz default, 3.3V LVDS)	Silicon Labs SI SI570BAB001544DG	40
10	U69	SI5341B 10 Independent Output Any-Frequency Clock Generator (PS Reference Clock) (I2C programmable any frequency clock generator)	Silicon Labs SI5341B-B05071-GM	39
11	U20	SFP/SFP+ Clock Recovery (jitter attenuated clock)	Silicon Labs SI5328B-C-GMR	41
12	U98/P12	Ethernet PHY LED Interface Ethernet PHY U98 with P12 RJ45 with magnetics	TI DP83867IRPAP, Würth 7499111221A	52
13	U40/J83	CP2108 USB UART Interface (bridge IC/USB Micro-B connector)	Silicon Labs CP2108-B02-GM, Hirose ZX62D-AB-5P8	42
14	U94/P7	HDMI Video Output (controller/connector)	TI SN65DP159RGZ, TEC Connectivity 1888811-1	35
15	U60, U61, U97	I2C0 (MIO 14-15) bus switch and expanders)	TI PCA9544ARGYR, 2 ea. TI TCA6416APWR	57
16	U34, U135	I2C1 (MIO 16-17) bus switches	TI TCA9548APWR, 2ea.	58
17	J54	SFP/SFP+ Connector (quad)	Allbest R-OP-008080-6-F-N-26-F63	34
18	U41	TI MSP430 System Controller	TI MSP430F5342	38
19	J55/J87	User PMOD GPIO Headers (PMOD0-RA receptacle/PMOD1-vert. male pin hdr.)	SULLINS PPPO062LJBN-RC, SULLINS PBC36DAAN	55

Table 2-1: ZCU102 Board Components (Cont'd)

Callout	Ref. Des.	Feature/Component	Notes	Schematic 0381701 Page Number
20	J160	For more information about PMOD connector compatible PMOD modules, see [Ref 30]. (PMOD I2C RA receptacle)	SULLINS PPPO062LJBN-RC	49
21	DS37-DS44	User I/O (8 LEDs)	GPIO LEDs, GREEN 0603	53
22	SW13	User I/O (8-pole DIP switch)	C&K SDA08H1SBD	53
23	SW14-SW18	User I/O (pushbutton switches, active-High)	E-Switch TL3301EP100QG placed in N, S, W, E, C pattern	53
24	SW20	User I/O (CPU_RESET pushbutton switch, active-High)	E-Switch TL3301EP100QG	53
25	SW8	DIP Switch, 5-pole, GPIO (TI MSP430 System Controller)	5 pole C&K SDA05H1SBD	38
26	SW3, SW4	Switches (SRST_RESET, POR_B pushbutton switches, active-Low)	E-Switch TL3301EP100QG	12
27	U122, J98	CAN1 (MIO 24-25) (bus transceiver/2x4 male header)	TI SN65HVD232, SULLINS PBC36DAAN	50
28	SW1	Power On/Off Slide Switch (Power On/Off slide switch)	C&K 1201M2S3AQE2	59
29	J52	Power connector (Power On/Off Slide Switch)	MOLEX 39-30-1060	59
30	SW5	Program_B Pushbutton (FPGA program)	E-Switch TL3301EP100QG	12
31	J5	FMC HPC0 Connector J5	Samtec ASP_134486_01	26-29
32	J4	FMC HPC1 Connector J4	Samtec ASP_134486_01	30-33
33	J10	Switched output power connector	TEC Connectivity 794285-1	59
34	-	Power management system (top and bottom)	Maxim Regulators	59-86
35	P1	PCI Express Root Port Slot (PCIe 4-lane connector)	FCI 10061913-101CLF	43
36	P11	DPAUX (MIO 27-30) (DisplayPort)	MOLEX 0472720001	44
37	J84	PMBus connector (Monitoring Voltage and Current)	ASSMANN AWHW16G-0202-T-R	57
38	J92	JTAG connector (TI MSP430 System Controller)	TYCO 5103308-2	38
39	J6	Arm JTAG connector (Programmable Logic JTAG Programming Options)	ASSMANN AWHW20G-0202-T-R	22
40	U108	HDMI Clock Recovery (High-Definition Multimedia Interface (HDMI™) jitter-attenuated clock)	Silicon Labs SI 5324C-C-GMR	37
41	J3	For more information about PMOD connector compatible PMOD modules, see [Ref 30]. MPSoC U1 Bank 50 GPIO 2x12 male pin proto header	SULLINS PBC36DAAN	56

Table 2-1: ZCU102 Board Components (Cont'd)

Callout	Ref. Des.	Feature/Component	Notes	Schematic 0381701 Page Number
42	J70-J72 J79-J80	SMA (MGTH interface SMA connectors)	ROSENBERGER 32K10K-400L5	40
43	P6	EMIO Arm Trace Port (Arm Trace receptacle)	MICTOR 2-5767004-2	54
44	SW6	Switches (mode 4-pole DIP switch)	4-pole C&K SDA04H1SBD	12
45	(Misc. DSnn)	Power and Status LEDs (Misc. LEDs)	Miscellaneous LEDs	86

Default Switch and Jumper Settings

Figure 2-2 shows the board jumper header and DIP switch locations. Each numbered component shown in the figure is keyed to Table 2-2 (for default switch settings) or Table 2-3 (for default jumper settings). Both tables reference the respective schematic page numbers.

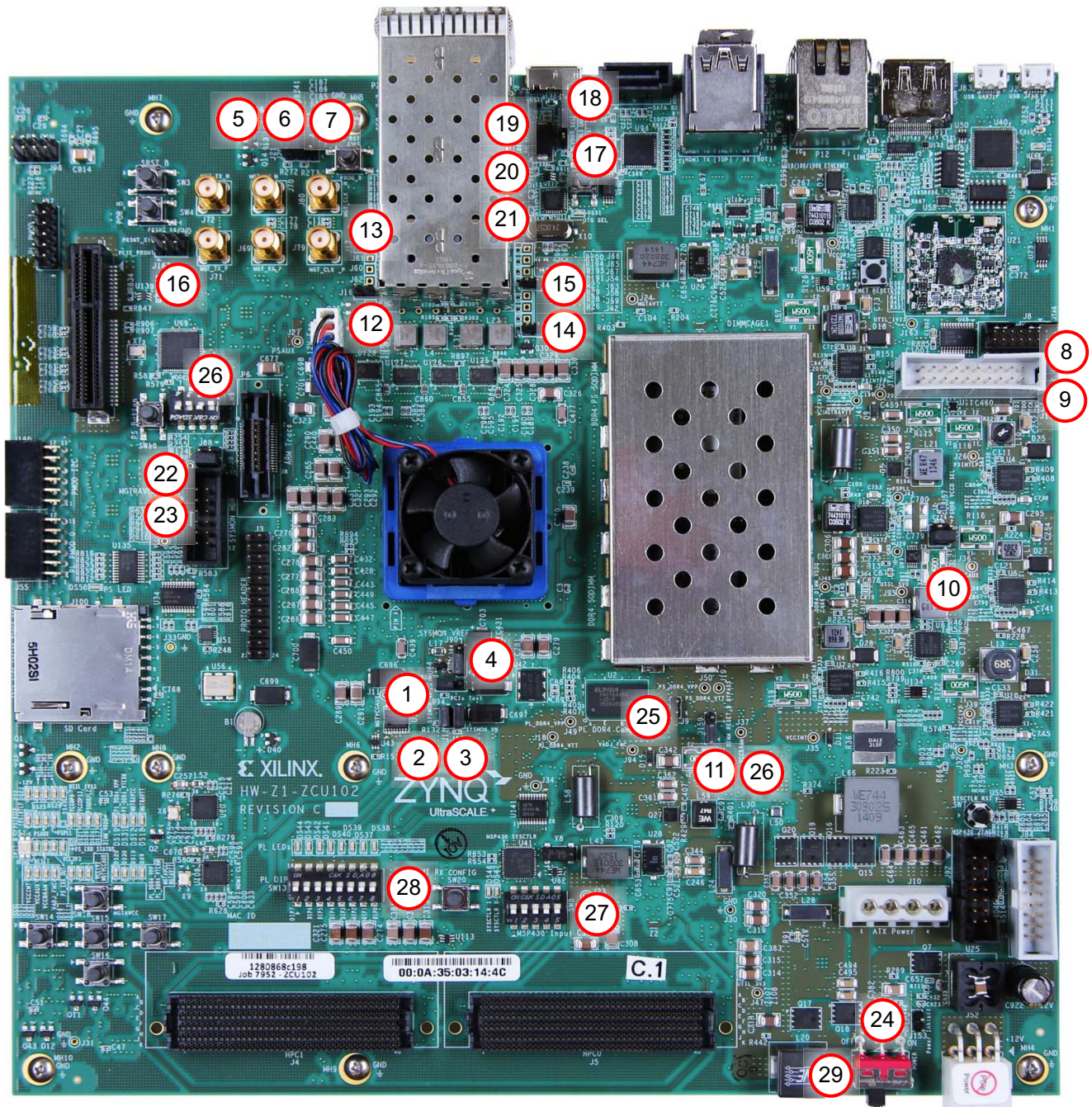

X16617-091718

Figure 2-2: DIP Switch and Board Header Jumper Locations

Switches

Table 2-2: Default Switch Settings

DIP Switch	Function	Default	Figure 2-2 Callout	Schematic Page
SW1	Main Power Switch	OFF	29	59
SW6	Switch PS_MODE select <ul style="list-style-type: none"> ON = pull down = 0 OFF = pull up = 1 MODE[3:0] = 0010 (selects QSPI32) 4: PS_MODE3 3: PS_MODE2 2: PS_MODE1 1: PS_MODE0	ON ON OFF ON	26	12
SW8	MSP430 GPIO 5-POLE <ul style="list-style-type: none"> ON = GND OFF = Open 1: SW0 2: SW1 3: SW2 4: SW3 5: SW4	OFF OFF OFF OFF OFF	27	38
SW13	GPIO 8-POLE <ul style="list-style-type: none"> OFF = pull down ON = pull up 	All OFF	28	53

Jumpers

Table 2-3: Default Jumper Settings

Jumper	Function	Default	Figure 2-2 Callout	Schematic Page
J85	POR_OVERRIDE <ul style="list-style-type: none"> 1-2: Enable 2-3: Disable 	2-3	1	3
J12	SYSMON I2C Address <ul style="list-style-type: none"> Open: SYSMON_VP_R floating 1-2: SYSMON_VP_P pulled down 	1-2	2	3
J13	SYSMON I2C Address <ul style="list-style-type: none"> Open: SYSMON_VN_R floating 1-2: SYSMON_VP_N pulled down 	1-2	3	3

Table 2-3: Default Jumper Settings (Cont'd)

Jumper	Function	Default	Figure 2-2 Callout	Schematic Page
J90	SYSMON VREFP <ul style="list-style-type: none"> • 1-2: 1.25V VREFP connected to FPGA • 2-3: VREFP connected to GND 	1-2	4	3
J20	Reset Sequencer PS_POR_B <ul style="list-style-type: none"> • OFF: No sequencer control of PS_POR_B • 1-2: Sequencer can control PS_POR_B 	1-2	5	12
J21	Reset Sequencer PS_SRST_B <ul style="list-style-type: none"> • OFF: No sequence control of PS_SRST_B • 1-2: Sequencer can control PS_SRST_B 	1-2	6	12
J22	Reset Sequencer inhibit <ul style="list-style-type: none"> • OFF: Sequencer normal operation • 1-2: Sequencer inhibit (resets will stay asserted) 	OFF	7	12
J14	Arm Debug VTREF <ul style="list-style-type: none"> • Open: VTREF floating • 1-2: VTREF = VCCOPS3 (1.8V) 	1-2	8	22
J15	Arm Debug VSUPPLY <ul style="list-style-type: none"> • OFF: VSUPPLY floating • 1-2: VSUPPLY = VCCOPS3 (1.8V) 	OFF	9	22
J56	VCCO_PSDDR_504 select <ul style="list-style-type: none"> • 1-2: Switched DDR4 VDDQ • 3-4: Direct DDR4 VDDQ 	1-2	10	24
J159	DDR4 Reset Suspend Enable <ul style="list-style-type: none"> • 1-2: Suspend disabled (Gate bypass) • 2-3: Suspend enabled 	1-2	11	24
J16	SFP0 TX: ON = SFP TX Enabled; OFF = SFP TX Disabled, allows FPGA Control	OFF	12	34
J17	SFP1 TX: ON = SFP TX Enabled; OFF = SFP TX Disabled, allows FPGA Control	OFF	12	34
J42	SFP2 TX: ON = SFP TX Enabled; OFF = SFP TX Disabled, allows FPGA Control	OFF	14	34
J54	SFP3 TX: ON = SFP TX Enabled; OFF = SFP TX Disabled, allows FPGA Control	OFF	15	34
J162	PCIe PRSNT select <ul style="list-style-type: none"> • 1-2: x1 • 3-4: x4 • 5-6: GND (not used) 	5-6	16	43

Table 2-3: Default Jumper Settings (Cont'd)

Jumper	Function	Default	Figure 2-2 Callout	Schematic Page
J110	USB ULPI CVBUS Select <ul style="list-style-type: none"> • 1-2: DEVICE or OTG Mode • 2-3: Host Mode 	1-2	17	51
J109	USB ULPI ID select <ul style="list-style-type: none"> • 1-2: Connector ID • 2-3: VDD33 ID 	2-3	18	51
J112	USB ULPI Shield GND select <ul style="list-style-type: none"> • 1-2: Capacitor • 2-3: GND 	1-2	19	51
J7	USB ULPI Device or Host select <ul style="list-style-type: none"> • 1-2: HOST/OTG • Open: Device 	OPEN	20	51
J113	USB ULPI Device/Host or OTG select <ul style="list-style-type: none"> • 1-2: Device or Host • 2-3: OTG 	1-2	21	51
J88	Arm Trace VTREF <ul style="list-style-type: none"> • 1-2: 3.3V • Open: 0V 	1-2	22	54
J38	Arm Trace power <ul style="list-style-type: none"> • 1-2: 3.3V • Open: 0V 	1-2	23	54
J153	Power inhibit <ul style="list-style-type: none"> • OFF: rails power on normally • 1-2: all rails (except UTIL) OFF 	OFF	24	59
J9	PS_DDR4_VPP_2V5 power inhibit (U39) <ul style="list-style-type: none"> • OFF: rail powers on normally • 1-2: PS_DDR4_VPP_2V5 OFF 	OFF	25	77
J164	MSP430 firmware upgrade header	OFF	26	38

MPSoC Device Configuration

Zynq UltraScale+ XCZU9EG MPSoC devices use a multi-stage boot process documented in the Boot and Configuration chapter of the *Zynq UltraScale+ MPSoC Technical Reference Manual* (UG1085) [Ref 3].

Switch SW6 configuration option settings are identified in [Table 2-4](#).

Table 2-4: Switch SW6 Configuration Option Settings

Boot Mode	Mode Pins [3:0]	Mode SW6 [4:1]
JTAG	0000	on, on, on, on
QSPI32	0010 ⁽¹⁾	on, on, off, on
SD	1110	off, off, off, on

Notes:

1. Default switch setting.
2. For this DIP switch, in relation to the arrow, moving the switch toward the label ON is a 0. DIP switch labels 1 through 4 are equivalent to Mode pins 0 through 3.

JTAG

Vivado, SDK, or third-party tools can establish a JTAG connection to the Zynq UltraScale+ MPSoC through one of the three provided JTAG interfaces:

1. Xilinx platform USB or cable PC4 connector (J8)
2. Arm 20-pin JTAG connector (J6)
3. Digilent SMT2.5 USB-to-JTAG module with off-module micro-USB connector (J2)

Quad-SPI

Booting from the dual Quad-SPI nonvolatile configuration memory is accomplished by storing a valid Zynq UltraScale+ MPSoC boot image into the Quad-SPI flash devices connected to the MIO Quad-SPI interface, setting the boot mode pins SW6 [4:1] = QSPI32 (see [Table 2-4](#)), then either power-cycling or pressing the power-on reset (POR) pushbutton. SW6 is callout 23 in [Figure 2-1](#).

SD

Booting from an SD card is accomplished by storing a valid Zynq UltraScale+ MPSoC boot image file onto an SD card (plugged into SD socket J100) connected to the MIO SD interface, setting the boot mode pins SW6 [4:1] = SD (see [Table 2-4](#)), then either power-cycling or pressing the power-on reset (POR) pushbutton.

See the *Zynq UltraScale+ MPSoC Technical Reference Manual* (UG1085) [Ref 3] for more information about Zynq UltraScale+ MPSoC configuration options.

Board Component Descriptions

Overview

This chapter provides a detailed functional description of the board’s components and features. [Table 2-1](#) identifies the components, references the respective schematic page numbers, and links to the corresponding detailed functional description in this chapter. Component locations are shown in [Figure 2-1](#).

Component Descriptions

Zynq UltraScale XCZU9EG MPSoC

[[Figure 2-1](#), callout 1]

The ZCU102 board is populated with the Zynq UltraScale+ XCZU9EG-2FFVB1156E MPSoC which combines a powerful processing system (PS) and user-programmable logic (PL) into the same device. The processing system in a Zynq UltraScale+ MPSoC features the Arm® flagship Cortex®-A53 64-bit quad-core processor and Cortex-R5 dual-core real-time processor.

Production ZCU102 Evaluation boards will ship with -2 speed grade devices. Support of multiple speed grades requires voltage adjustments.

The PL-side V_{CCINT} supply will be user adjustable via PMBUS with the voltage ranges shown in [Table 3-1](#) to support multiple Zynq UltraScale+ MPSoC speed grades.

Table 3-1: Recommended Operating Conditions

Symbol	Description	Min.	Typ.	Max.	Units
Programmable Logic (PL)					
V_{CCINT}	PL internal supply voltage.	0.825	0.850	0.876	V
	For -1LI and -2LE ($V_{CCINT} = 0.72V$) devices: PL internal supply voltage.	0.698	0.720	0.742	V
	For -3E devices: PL internal supply voltage.	0.873	0.900	0.927	V

The top-level block diagram is shown in Figure 3-1.

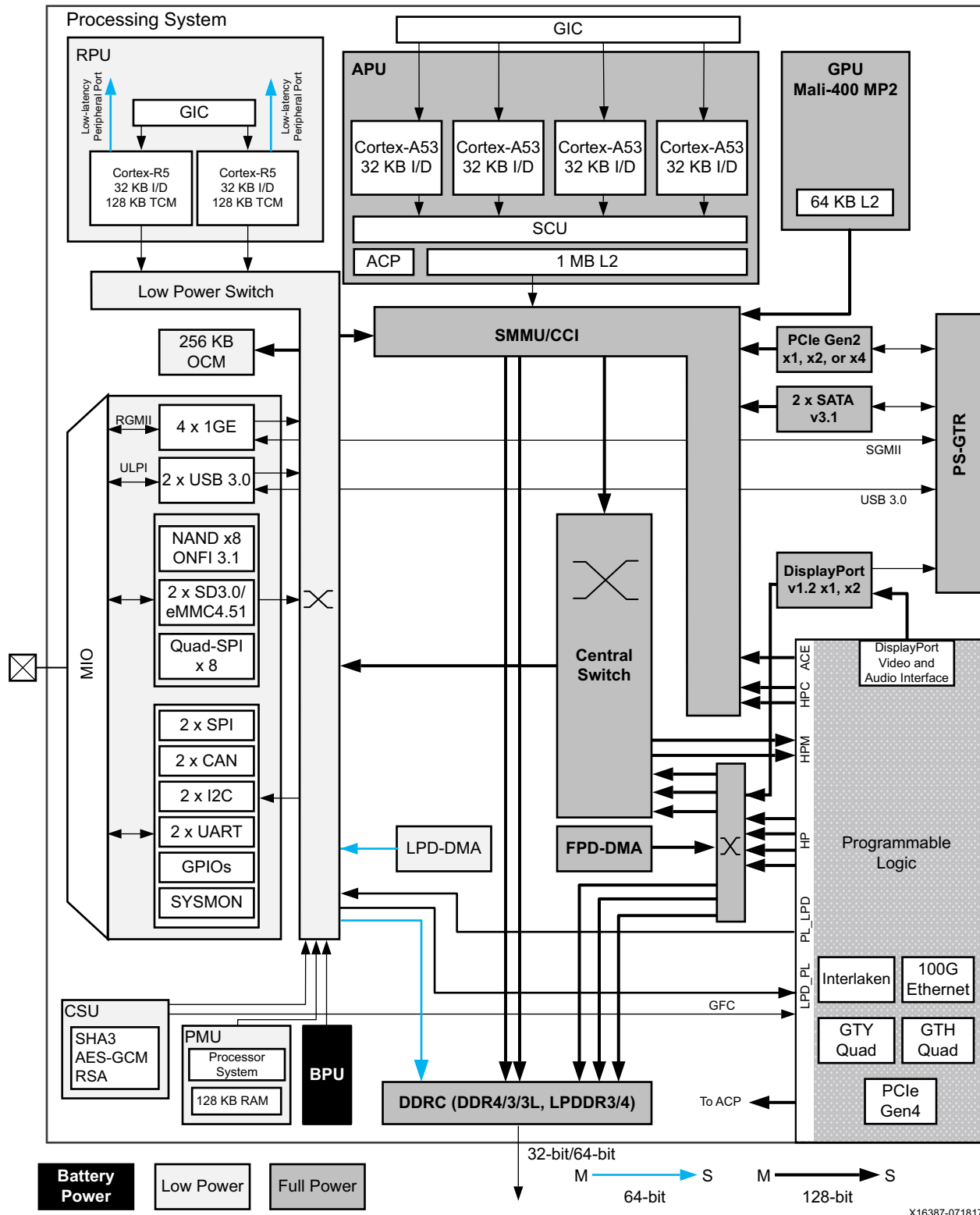

Figure 3-1: Zynq UltraScale+ MPSoC Top-Level Block Diagram

The Zynq UltraScale+ MPSoC PS block has three major processing units:

- Cortex-A53 application processing unit (APU)-Arm v8 architecture-based 64-bit quad-core multiprocessing CPU.
- Cortex-R5 real-time processing unit (RPU)-Arm v7 architecture-based 32-bit dual real-time processing unit with dedicated tightly coupled memory (TCM).
- Mali-400 graphics processing unit (GPU)-graphics processing unit with pixel and geometry processor and 64 KB L2 cache.

The Zynq UltraScale+ MPSoC PS has four high-speed serial I/O (HSSIO) interfaces supporting the following protocols:

- Integrated block for PCI Express® interface-PCIe™ base specification version 2.1 compliant.
- SATA 3.1 specification compliant interface.
- DisplayPort interface-implements a DisplayPort source-only interface with video resolution up to 4K x 2K-30 (300 MHz pixel rate).
- USB 3.0 interface-compliant to USB 3.0 specification implementing a 5 Gb/s line rate.
- Serial GMII interface-supports a 1 Gb/s SGMII interface.

The PS and PL can be coupled with multiple interfaces and other signals to effectively integrate user-created hardware accelerators and other functions in the PL logic that are accessible to the processors. They can also access memory resources in the processing system. The PS I/O peripherals, including the static/flash memory interfaces share a multiplexed I/O (MIO) of up to 78 MIO pins. Zynq UltraScale+ MPSoCs can also use the I/O in the PL domain for many of the PS I/O peripherals. This is done through an extended multiplexed I/O interface (EMIO).and boots at power-up or reset.

For additional information on Zynq UltraScale+ MPSoC devices, see the *Zynq UltraScale+ MPSoC Data Sheet: Overview* (DS891) [Ref 1], and the *Zynq UltraScale+ MPSoC Technical Reference Manual* (UG1085) [Ref 3] for more information about Zynq UltraScale+ MPSoC configuration options.

Encryption Key Backup Circuit

The XCZU9EG MPSoC U1 implements bitstream encryption key technology. The ZCU102 board provides the encryption key backup battery circuit shown in Figure 3-2.

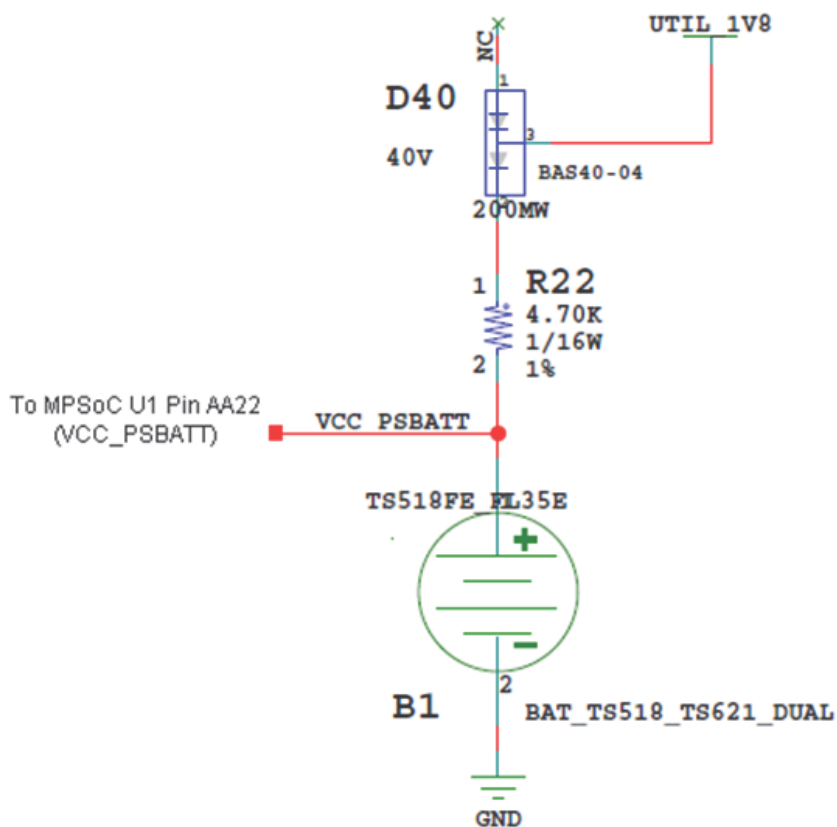

X16523-071817

Figure 3-2: Encryption Key Backup Circuit

The Seiko TS518FE rechargeable 1.5V lithium button-type battery B1 is soldered to the board with the positive output connected to the XCZU9EG MPSoC U1 V_{CC_PSBATT} pin AA22. The battery supply current I_{BATT} specification is 150 nA maximum when board power is off. B1 is charged from the UTIL_1V8 1.8V rail through a series diode with a typical forward voltage drop of 0.38V and 4.7 kΩ current limit resistor. The nominal charging voltage is 1.42V.

I/O Voltage Rails

There are nine PL I/O banks available on the XCZU9EG MPSoC. The voltages applied to the XCZU9EG MPSoC I/O banks used by the ZCU102 board are listed in [Table 3-2](#).

Table 3-2: I/O Voltage Rails

XCZU9EG	Power Net Name	Voltage	Connected To
PL Bank 0	NA	NA	MPSoC Configuration Bank 0
PL Bank 44	V _{CC3V3}	3.3V	GPIO DIP SW, PB SW, LEDs, 74.25 MHz CLK
PL Bank 47	V _{CC3V3}	3.3V	GPIO PMOD0 (RT-ANG. FEMALE), PMOD1 (STR. MALE), PL I2C1, TRACEDATA, 125 MHz CLK
PL Bank 48	V _{CC3V3}	3.3V	TRACEDATA
PL Bank 49	V _{CC3V3}	3.3V	High-Definition Multimedia Interface (HDMI™) Codec, SYSMON I2C, SFP CTRL, UART2, MSP430 UCA1
PL Bank 50	V _{CC3V3}	3.3V	HDMI Codec, MSP430 GPIO, PL I2C0, PROTO. HDR. IO
PL Bank 64	V _{CC1V2}	1.2V	DDR4 DQ[0:15], DDR4 ADDR/CTRL, USER_SI570 CLK
PL Bank 65	V _{ADJ_FMC} ⁽¹⁾	1.8V	FMC_HPC1 LA BUS, HDMI TX
PL Bank 66	V _{ADJ_FMC} ⁽¹⁾	1.8V	FMC_HPC0 LA BUS, HDMI REC CLK
PL Bank 67	V _{ADJ_FMC} ⁽¹⁾	1.8V	FMC_HPC0 LA BUS, SFP REC CLK
PS Bank 500	V _{CCOPS}	1.8V	QSPI LWR, QSPI UPR, UART1, MIO_I2C0, MIO_I2C1, MIO_RXD/TXD, CAN IF
PS Bank 501	V _{CCOPS}	1.8V	MIO_SD IF, MIO_PMU IF, MIO_DP IF
PS Bank 502	V _{CCOPS}	1.8V	MIO_ENET, MIO_USB
PS Bank 503	V _{CCOPS3}	1.81V	PS CONFIGURATION IF
PS DDR Bank 504	V _{CCO_PSDDR_504}	1.2V	DDR4 SODIMM IF

Notes:

1. The ZCU102 board is shipped with V_{ADJ_FMC} set to 1.8V by the MSP430 system controller.

PS-Side: DDR4 SODIMM Socket

[Figure 2-1, callout 2]

The PS-side memory is wired to the Zynq UltraScale+ DDRC hard memory controller. The PS-side memory interface supports a 260-pin DDR4 SODIMM socket J1. The ZCU102 is shipped with a DDR4 SODIMM installed:

- Manufacturer: Micron
- Part Number: MTA4ATF51264HZ-2G6E1
- Description:
 - 4 GB DDR4 SODIMM, 260-pin
 - Single Rank x16
 - 512 Mbit x 64-bit
 - Supports up to DDR4-2666

The ZCU102 XCZU9EG FFVB MPSoC PS DDR interface performance is documented in the *Zynq UltraScale+ MPSoC Data Sheet: DC and AC Switching Characteristics (DS925)* [Ref 2].

The ZCU102 supports full power-off suspend mode where only the system controller and the PS-side DDR4 SODIMM memory are powered. The DDR4 memory is kept in a self-refresh state and has its reset input controlled by the system controller such that the memory is not reset when waking-up from suspend mode. DDR4 SODIMM standard right angle Socket J1 connections are identified in Table 3-3.

Table 3-3: DDR4 SODIMM Socket J1 Connections to FPGA PS DDR Bank 504

XCZU9EG (U1) Pin	Net Name	DDR4 SODIMM Memory J1	
		Pin Number	Pin Name
AP29	DDR4_SODIMM_A0	144	A0
AP30	DDR4_SODIMM_A1	133	A1
AP26	DDR4_SODIMM_A2	132	A2
AP27	DDR4_SODIMM_A3	131	A3
AP25	DDR4_SODIMM_A4	128	A4
AN24	DDR4_SODIMM_A5	126	A5
AM29	DDR4_SODIMM_A6	127	A6
AM28	DDR4_SODIMM_A7	122	A7
AM26	DDR4_SODIMM_A8	125	A8
AM25	DDR4_SODIMM_A9	121	A9
AL28	DDR4_SODIMM_A10	146	A10/AP
AK27	DDR4_SODIMM_A11	120	A11

Table 3-3: DDR4 SODIMM Socket J1 Connections to FPGA PS DDR Bank 504 (Cont'd)

XCZU9EG (U1) Pin	Net Name	DDR4 SODIMM Memory J1	
		Pin Number	Pin Name
AJ25	DDR4_SODIMM_A12	119	A12
AL25	DDR4_SODIMM_A13	158	A13
AH26	DDR4_SODIMM_BA0	150	BA0
AG26	DDR4_SODIMM_BA1	145	BA1
AK28	DDR4_SODIMM_BG0	115	BG0
AH27	DDR4_SODIMM_BG1	113	BG1
AP20	DDR4_SODIMM_DQ0	8	DQ0
AP18	DDR4_SODIMM_DQ1	7	DQ1
AP19	DDR4_SODIMM_DQ2	20	DQ2
AP17	DDR4_SODIMM_DQ3	21	DQ3
AM20	DDR4_SODIMM_DQ4	4	DQ4
AM19	DDR4_SODIMM_DQ5	3	DQ5
AM18	DDR4_SODIMM_DQ6	16	DQ6
AL18	DDR4_SODIMM_DQ7	17	DQ7
AP22	DDR4_SODIMM_DQ8	28	DQ8
AP21	DDR4_SODIMM_DQ9	29	DQ9
AP24	DDR4_SODIMM_DQ10	41	DQ10
AN23	DDR4_SODIMM_DQ11	42	DQ11
AL21	DDR4_SODIMM_DQ12	24	DQ12
AL22	DDR4_SODIMM_DQ13	25	DQ13
AM23	DDR4_SODIMM_DQ14	38	DQ14
AL23	DDR4_SODIMM_DQ15	37	DQ15
AL20	DDR4_SODIMM_DQ16	50	DQ16
AK20	DDR4_SODIMM_DQ17	49	DQ17
AJ20	DDR4_SODIMM_DQ18	62	DQ18
AK18	DDR4_SODIMM_DQ19	63	DQ19
AG20	DDR4_SODIMM_DQ20	46	DQ20
AH18	DDR4_SODIMM_DQ21	45	DQ21
AG19	DDR4_SODIMM_DQ22	58	DQ22
AG18	DDR4_SODIMM_DQ23	59	DQ23
AG21	DDR4_SODIMM_DQ24	70	DQ24
AH21	DDR4_SODIMM_DQ25	71	DQ25
AG24	DDR4_SODIMM_DQ26	83	DQ26
AG23	DDR4_SODIMM_DQ27	84	DQ27

Table 3-3: DDR4 SODIMM Socket J1 Connections to FPGA PS DDR Bank 504 (Cont'd)

XCZU9EG (U1) Pin	Net Name	DDR4 SODIMM Memory J1	
		Pin Number	Pin Name
AK22	DDR4_SODIMM_DQ28	66	DQ28
AJ21	DDR4_SODIMM_DQ29	67	DQ29
AJ22	DDR4_SODIMM_DQ30	79	DQ30
AK23	DDR4_SODIMM_DQ31	80	DQ31
AG31	DDR4_SODIMM_DQ32	174	DQ32
AG30	DDR4_SODIMM_DQ33	173	DQ33
AG29	DDR4_SODIMM_DQ34	187	DQ34
AG28	DDR4_SODIMM_DQ35	186	DQ35
AJ30	DDR4_SODIMM_DQ36	170	DQ36
AK29	DDR4_SODIMM_DQ37	169	DQ37
AK30	DDR4_SODIMM_DQ38	183	DQ38
AJ29	DDR4_SODIMM_DQ39	182	DQ39
AE27	DDR4_SODIMM_DQ40	195	DQ40
AF28	DDR4_SODIMM_DQ41	194	DQ41
AF30	DDR4_SODIMM_DQ42	207	DQ42
AF31	DDR4_SODIMM_DQ43	208	DQ43
AD28	DDR4_SODIMM_DQ44	191	DQ44
AD27	DDR4_SODIMM_DQ45	190	DQ45
AD29	DDR4_SODIMM_DQ46	203	DQ46
AD30	DDR4_SODIMM_DQ47	204	DQ47
AH33	DDR4_SODIMM_DQ48	216	DQ48
AJ34	DDR4_SODIMM_DQ49	215	DQ49
AH34	DDR4_SODIMM_DQ50	228	DQ50
AH32	DDR4_SODIMM_DQ51	229	DQ51
AK34	DDR4_SODIMM_DQ52	211	DQ52
AK33	DDR4_SODIMM_DQ53	212	DQ53
AL32	DDR4_SODIMM_DQ54	224	DQ54
AL31	DDR4_SODIMM_DQ55	225	DQ55
AG33	DDR4_SODIMM_DQ56	237	DQ56
AG34	DDR4_SODIMM_DQ57	236	DQ57
AF32	DDR4_SODIMM_DQ58	249	DQ58
AF33	DDR4_SODIMM_DQ59	250	DQ59
AD31	DDR4_SODIMM_DQ60	232	DQ60
AD32	DDR4_SODIMM_DQ61	233	DQ61

Table 3-3: DDR4 SODIMM Socket J1 Connections to FPGA PS DDR Bank 504 (Cont'd)

XCZU9EG (U1) Pin	Net Name	DDR4 SODIMM Memory J1	
		Pin Number	Pin Name
AD34	DDR4_SODIMM_DQ62	245	DQ62
AD33	DDR4_SODIMM_DQ63	246	DQ63
AN31	DDR4_SODIMM_CB0	92	CB0/NC
AP31	DDR4_SODIMM_CB1	91	CB1/NC
AP32	DDR4_SODIMM_CB2	101	CB2/NC
AP33	DDR4_SODIMM_CB3	105	CB3/NC
AM31	DDR4_SODIMM_CB4	88	CB4/NC
AM33	DDR4_SODIMM_CB5	87	CB5/NC
AM34	DDR4_SODIMM_CB6	100	CB6/NC
AL33	DDR4_SODIMM_CB7	104	CB7/NC
AN17	DDR4_SODIMM_DM0_B	12	DM0_N/DBI0_N
AM21	DDR4_SODIMM_DM1_B	33	DM1_N/DBI1_N
AK19	DDR4_SODIMM_DM2_B	54	DM2_N/DBI2_N
AH24	DDR4_SODIMM_DM3_B	75	DM3_N/DBI3_N
AH31	DDR4_SODIMM_DM4_B	178	DM4_N/DBI4_N
AE30	DDR4_SODIMM_DM5_B	199	DM5_N/DBI5_N
AJ31	DDR4_SODIMM_DM6_B	220	DM6_N/DBI6_N
AE34	DDR4_SODIMM_DM7_B	241	DM7_N/DBI7_N
AN34	DDR4_SODIMM_DM8_B	96	DM8_N/DBI8_N/NC
AN18	DDR4_SODIMM_DQS0_T	13	DQS0_T
AN19	DDR4_SODIMM_DQS0_C	11	DQS0_C
AN21	DDR4_SODIMM_DQS1_T	34	DQS1_T
AN22	DDR4_SODIMM_DQS1_C	32	DQS1_C
AH19	DDR4_SODIMM_DQS2_T	55	DQS2_T
AJ19	DDR4_SODIMM_DQS2_C	53	DQS2_C
AH22	DDR4_SODIMM_DQS3_T	76	DQS3_T
AH23	DDR4_SODIMM_DQS3_C	74	DQS3_C
AH28	DDR4_SODIMM_DQS4_T	179	DQS4_T
AH29	DDR4_SODIMM_DQS4_C	177	DQS4_C
AE28	DDR4_SODIMM_DQS5_T	200	DQS5_T
AE29	DDR4_SODIMM_DQS5_C	198	DQS5_C
AJ32	DDR4_SODIMM_DQS6_T	221	DQS6_T
AK32	DDR4_SODIMM_DQS6_C	219	DQS6_C
AE32	DDR4_SODIMM_DQS7_T	242	DQS7_T

Table 3-3: DDR4 SODIMM Socket J1 Connections to FPGA PS DDR Bank 504 (Cont'd)

XCZU9EG (U1) Pin	Net Name	DDR4 SODIMM Memory J1	
		Pin Number	Pin Name
AE33	DDR4_SODIMM_DQS7_C	240	DQS7_C
AN32	DDR4_SODIMM_DQS8_T	97	DQS8_T
AN33	DDR4_SODIMM_DQS8_C	95	DQS8_C
AN27	DDR4_SODIMM_CK0_C	139	CK0_C
AN26	DDR4_SODIMM_CK0_T	137	CK0_T
AL27	DDR4_SODIMM_CK1_C	140	CK1_C/NF
AL26	DDR4_SODIMM_CK1_T	138	CK1_T/NF
AN29	DDR4_SODIMM_CKE0	109	CKE0
AJ27	DDR4_SODIMM_CKE1	110	CKE1
AM30	DDR4_SODIMM_ODT0	155	ODT0
AJ26	DDR4_SODIMM_ODT1	161	ODT1
AM24	DDR4_SODIMM_RAS_B	152	RAS_N/A16
AK24	DDR4_SODIMM_CAS_B	156	CAS_N/A15
AK25	DDR4_SODIMM_WE_B	151	WE_N/A14
AG25	DDR4_SODIMM_ACT_B	114	ACT_N
AF22	DDR4_SODIMM_ALERT_B	116	ALERT_N
AF20	DDR4_SODIMM_PARITY	143	PARITY
AN28	DDR4_SODIMM_CS0_B	149	CS0_N
AL30	DDR4_SODIMM_CS1_B	157	CS1_N

The ZCU102 DDR4 SODIMM interface adheres to the constraints guidelines documented in the PCB Guidelines for DDR4 section of *UltraScale Architecture PCB Design Guide* (UG583) [Ref 5]. The ZCU102 DDR4 SODIMM interface is a 40Ω impedance implementation. Other memory interface details are also available in the *UltraScale Architecture FPGAs Memory Interface Solutions Guide* (PG150) [Ref 6].

PL-Side: DDR4 Component Memory

[Figure 2-1, callout 3]

The 4 Gb, 16-bit wide DDR4 memory system is comprised of one 256 Mb x 16 SDRAM at U2.

- Manufacturer: Micron
- Part Number: MT40A256M16GE-075E

- Description:
 - 4 Gb (256 Mb x16)
 - 1.2V 96 ball TFBGA
 - DDR4-2666

The ZCU102 XCZU9EG FFVB MPSoC PL DDR interface performance is documented in the *Zynq UltraScale+ MPSoC Data Sheet: DC and AC Switching Characteristics (DS925)* [Ref 2].

This memory system is connected to the XCZU9EG device bank 64. The DDR4 0.6V VTT termination voltage (net DDR4_VTT) is sourced from the TI TPS51200DR linear regulator U35. The connections between the DDR4 component memory and XCZU9EG device bank 64 are listed in [Table 3-4](#).

Table 3-4: DDR4 Component Memory Connection to the XCZU9EG MPSoC

XCZU9EG (U1) Pin	Net Name	I/O Standard	DDR4 Component Memory	
			Pin Number	Pin Name
AM8	DDR4_A0	SSTL12_DCI	P3	A0
AM9	DDR4_A1	SSTL12_DCI	P7	A1
AP8	DDR4_A2	SSTL12_DCI	R3	A2
AN8	DDR4_A3	SSTL12_DCI	N7	A3
AK10	DDR4_A4	SSTL12_DCI	N3	A4
AJ10	DDR4_A5	SSTL12_DCI	P8	A5
AP9	DDR4_A6	SSTL12_DCI	P2	A6
AN9	DDR4_A7	SSTL12_DCI	R8	A7
AP10	DDR4_A8	SSTL12_DCI	R2	A8
AP11	DDR4_A9	SSTL12_DCI	R7	A9
AM10	DDR4_A10	SSTL12_DCI	M3	A10/AP
AL10	DDR4_A11	SSTL12_DCI	T2	A11
AM11	DDR4_A12	SSTL12_DCI	M7	A12/BC_B
AL11	DDR4_A13	SSTL12_DCI	T8	A13
AK12	DDR4_BA0	SSTL12_DCI	N2	BA0
AJ12	DDR4_BA1	SSTL12_DCI	N8	BA1
AK7	DDR4_BG0	SSTL12_DCI	M2	BG0
AJ7	DDR4_A14_WE_B	SSTL12_DCI	L2	WE_B/A14
AJ9	DDR4_A16_RAS_B	SSTL12_DCI	L8	RAS_B/A16
AL5	DDR4_A15_CAS_B	SSTL12_DCI	M8	CAS_B/A15
AN7	DDR4_CK_T	DIFF_SSTL12	K7	CK_T
AP7	DDR4_CK_C	DIFF_SSTL12	K8	CK_C

Table 3-4: DDR4 Component Memory Connection to the XCZU9EG MPSoC (Cont'd)

XCZU9EG (U1) Pin	Net Name	I/O Standard	DDR4 Component Memory	
			Pin Number	Pin Name
AM3	DDR4_CKE	SSTL12_DCI	K2	CKE
AK8	DDR4_ACT_B	SSTL12_DCI	L3	ACT_B
AP1	DDR4_PAR	SSTL12_DCI	T3	PAR
AH9	DDR4_RESET_B_LS	LVC MOS18	P1	RESET_B
AK9	DDR4_ODT	SSTL12_DCI	K3	ODT
AP2	DDR4_CS_B	SSTL12_DCI	L7	CS_B
AK4	DDR4_DQ0	POD12_DCI	G2	DQL0
AK5	DDR4_DQ1	POD12_DCI	F7	DQL1
AN4	DDR4_DQ2	POD12_DCI	H3	DQL2
AM4	DDR4_DQ3	POD12_DCI	H7	DQL3
AP4	DDR4_DQ4	POD12_DCI	H2	DQL4
AP5	DDR4_DQ5	POD12_DCI	H8	DQL5
AM5	DDR4_DQ6	POD12_DCI	J3	DQL6
AM6	DDR4_DQ7	POD12_DCI	J7	DQL7
AK2	DDR4_DQ8	POD12_DCI	A3	DQU0
AK3	DDR4_DQ9	POD12_DCI	B8	DQU1
AL1	DDR4_DQ10	POD12_DCI	C3	DQU2
AK1	DDR4_DQ11	POD12_DCI	C7	DQU3
AN1	DDR4_DQ12	POD12_DCI	C2	DQU4
AM1	DDR4_DQ13	POD12_DCI	C8	DQU5
AP3	DDR4_DQ14	POD12_DCI	D3	DQU6
AN3	DDR4_DQ15	POD12_DCI	D7	DQU7
AN6	DDR4_DQS0_T	DIFF_POD12	G3	DQSL_T
AP6	DDR4_DQS0_C	DIFF_POD12	F3	DQSL_C
AL3	DDR4_DQS1_T	DIFF_POD12	B7	DQSU_T
AL2	DDR4_DQS1_C	DIFF_POD12	A7	DQSU_C
AL6	DDR4_DM0	POD12_DCI	E7	DML_B/DBIL_B
AN2	DDR4_DM1	POD12_DCI	E2	DMU_B/DBIU_B

Note: The ZCU102 board DDR4 16-bit component memory interface adheres to the constraints guidelines documented in the PCB Guidelines for DDR4 section of *UltraScale Architecture PCB Design User Guide* (UG583) [Ref 5]. The ZCU102 DDR4 component interface is a 40Ω impedance implementations. Other memory interface details are also available in the *UltraScale Architecture FPGAs Memory Interface Solutions Product Guide* (PG150) [Ref 6]. For more details, see the Micron MT40A256M16GE-075E data sheet at the Micron website [Ref 20].

PSMIO

Table 3-5 provides PS MIO peripheral mapping implemented on the ZCU102 board. See the *Zynq UltraScale+ MPSoC Technical Reference Manual (UG1085)* [Ref 3] for more information on PS MIO peripheral mapping.

Table 3-5: ZCU102 MIO Connections

MIO [25:0] Bank 500	ZU7EV U1 Pin No.	Schematic Net Name	Type	MIO [51:26] Bank 501	ZU7EV U1 Pin No.	Schematic Net Name	Type	MIO [77:52] Bank 502	ZU7EV U1 Pin No.	Schematic Net Name	Type
MIO25	AE19	MIO25_CAN_RX	CAN1	MIO51	N25	MIO51_SDIO_CLK_R	SD1	MIO77	F25	MIO77_ENET_MDIO	MDIO3
MIO24	AE20	MIO24_CAN_TX	CAN1	MIO50	P25	MIO50_SDIO_CMD_R	SD1	MIO76	H25	MIO76_ENET_MDC	MDIO3
MIO23	AD19	MIO23_LED	GPIO	MIO49	K25	MIO49_SDIO_DAT3_R	SD1	MIO75	D25	MIO75_ENET_RX_CTRL	GEM3
MIO22	AD20	MIO22_BUTTON	GPIO	MIO48	M25	MIO48_SDIO_DAT2_R	SD1	MIO74	G25	MIO74_ENET_RX_D3	GEM3
MIO21	AF18	MIO21_UART1_RXD	UART1	MIO47	L25	MIO47_SDIO_DAT1_R	SD1	MIO73	H24	MIO73_ENET_RX_D2	GEM3
MIO20	AD18	MIO20_UART1_TXD	UART1	MIO46	J25	MIO46_SDIO_DAT0_R	SD1	MIO72	E25	MIO72_ENET_RX_D1	GEM3
MIO19	AL17	MIO19_UART0_TXD	UART0	MIO45	P24	MIO45_SDIO_DETECT	SD1	MIO71	C27	MIO71_ENET_RX_D0	GEM3
MIO18	AE18	MIO18_UART0_RXD	UART0	MIO44	N24	MIO44_SDIO_PROTECT	SD1	MIO70	C26	MIO70_ENET_RX_CLK	GEM3
MIO17	AP16	MIO17_I2C1_SDA	I2C1	MIO43	K24	Not Connected	NC	MIO69	B27	MIO69_ENET_TX_CTRL	GEM3
MIO16	AM16	MIO16_I2C1_SCL	I2C1	MIO42	M24	MIO42_SDIO_DIR_DAT1	SD1	MIO68	B26	MIO68_ENET_TX_D3	GEM3
MIO15	AN16	MIO15_I2C0_SDA	I2C0	MIO41	J24	MIO41_SDIO_DIR_DAT0	SD1	MIO67	B25	MIO67_ENET_TX_D2	GEM3
MIO14	AL16	MIO14_I2C0_SCL	I2C0	MIO40	M23	MIO40_SDIO_DIR_CMD	SD1	MIO66	A27	MIO66_ENET_TX_D1	GEM3
MIO13	AK17	MIO13_PS_GPIO2	GPIO	MIO39	N23	MIO39_SDIO_SEL	SD1	MIO65	A26	MIO65_ENET_TX_D0	GEM3
MIO12	AJ17	MIO12_QSPI_UPR_CLK	QSP1	MIO38	L23	MIO38_PS_GPIO1	GPIO	MIO64	A25	MIO64_ENET_TX_CLK	GEM3
MIO11	AF17	MIO11_QSPI_UPR_DQ3	QSP1	MIO37	N22	MIO37_PMU_GPO5	PM OUT	MIO63	D24	MIO63_USB_DATA7_R	USB0
MIO10	AH17	MIO10_QSPI_UPR_DQ2	QSP1	MIO36	K23	MIO36_PMU_GPO4	PM OUT	MIO62	G24	MIO62_USB_DATA6_R	USB0
MIO9	AP15	MIO9_QSPI_UPR_DQ1	QSP1	MIO35	P22	MIO35_PMU_GPO3	PM OUT	MIO61	C24	MIO61_USB_DATA5_R	USB0
MIO8	AE17	MIO8_QSPI_UPR_DQ0	QSP1	MIO34	L22	MIO34_PMU_GPO2	PM OUT	MIO60	E24	MIO60_USB_DATA4_R	USB0
MIO7	AD17	MIO7_QSPI_UPR_CS_B	QSP1	MIO33	H23	MIO33_PMU_GPO1	PM OUT	MIO59	B24	MIO59_USB_DATA3_R	USB0
MIO6	AL15	Not Connected	NC	MIO32	H22	MIO32_PMU_GPO0	PM OUT	MIO58	G23	MIO58_USB_STP_R	USB0
MIO5	AM15	MIO5_QSPI_LWR_CS_B	QSP1	MIO31	J22	MIO31_PCIE_RESET_N	PCIE	MIO57	A23	MIO57_USB_DATA1_R	USB0
MIO4	AH16	MIO4_QSPI_LWR_DQ0	QSP1	MIO30	L21	MIO30_DP_AUX_IN	DPAUX	MIO56	C23	MIO56_USB_DATA0_R	USB0
MIO3	AG16	MIO3_QSPI_LWR_DQ3	QSP1	MIO29	K22	MIO29_DP_OE	DPAUX	MIO55	B23	MIO55_USB_NXT	USB0
MIO2	AD16	MIO2_QSPI_LWR_DQ2	QSP1	MIO28	N21	MIO28_DP_HPD	DPAUX	MIO54	F23	MIO54_USB_DATA2_R	USB0
MIO1	AJ16	MIO1_QSPI_LWR_DQ1	QSP1	MIO27	M21	MIO27_DP_AUX_OUT	DPAUX	MIO53	E23	MIO53_USB_DIR	USB0
MIO0	AF16	MIO0_QSPI_LWR_CLK	QSP1	MIO26	P21	MIO26_PMU_INPUT	PMU IN	MIO52	F22	MIO52_USB_CLK	USB0

Quad-SPI Flash Memory (MIO 0–12)

[Figure 2-1, callout 4]

The Micron dual MT25QU512ABB8ESF serial NOR flash Quad-SPI memories are capable of holding the boot image for the MPSoC system. To achieve higher performance two Quad-SPI devices are connected in parallel and provide an 8-bit data bus for booting and

configuration. This interface is used to support QSPI32 boot mode as defined in the *Zynq UltraScale+ MPSoC Technical Reference Manual* (UG1085) [Ref 3].

The dual Quad-SPI flash memory located at U119/U120 provides 1 Gb of non-volatile storage that can be used for configuration and data storage.

- Part number: MT25QU512ABB8ESF-0SIT (Micron)
- Supply voltage: 1.8V
- Datapath width: 8 bits
- Data rate: Various depending on Single/Dual/Quad mode

The connections between the SPI flash memory and the XCZU9EG MPSoC are listed in [Table 3-6](#).

Table 3-6: Quad-SPI Component Connections to FPGA U1

XCZU9EG (U1) Pin	Net Name	Quad-SPI U119 (LWR), U120 (UPR)	
		Pin Number	Pin Name
AH16	MIO4_QSPI_LWR_DQ0	15	DQ0
AJ16	MIO1_QSPI_LWR_DQ1	8	DQ1
AD16	MIO2_QSPI_LWR_DQ2	9	DQ2_WP_B
AG16	MIO3_QSPI_LWR_DQ3	1	DQ3_RST_HOLD_B
AF16	MIO0_QSPI_LWR_CLK	16	C
AM15	MIO5_QSPI_LWR_CS_B	7	S_B
AE17	MIO8_QSPI_UPR_DQ0	15	DQ0
AP15	MIO9_QSPI_UPR_DQ1	8	DQ1
AH17	MIO10_QSPI_UPR_DQ2	9	DQ2_WP_B
AF17	MIO11_QSPI_UPR_DQ3	1	DQ3_RST_HOLD_B
AJ17	MIO12_QSPI_UPR_CLK	16	C
AD17	MIO7_QSPI_UPR_CS_B	7	S_B

The configuration and Quad-SPI section of the *Zynq UltraScale+ MPSoC Technical Reference Manual* (UG1085) [Ref 3] provides details on using the Quad-SPI flash memory. For more QSPI details, see the Micron MT25QU512ABB8ESF-0SIT data sheet at the Micron website [Ref 20].

USB0 (MIO 52-63)

The USB interface on the PS-side serves multiple roles as a host, device, and OTG controller. The USB 3.0 interface is supported by the MPSoC GTR interface while the USB 2.0

capabilities of the SMSC USB3320C controller are shared on a common USB 3.0 micro USB type AB connector (J96).

USB 3.0 Transceiver and USB 2.0 ULPI PHY

[Figure 2-1, callout 5]

The ZCU102 board uses a Standard Microsystems Corporation USB3320 USB 2.0 ULPI Transceiver at U116 to support a USB connection to the host computer (see Figure 3-3). A USB cable is supplied in the ZCU102 Evaluation Kit (standard-A connector to host computer, micro-B connector to ZCU102 board connector J96). The USB3320 is a high-speed USB 2.0 PHY supporting the UTMI+ low pin interface (ULPI) interface standard. The ULPI standard defines the interface between the USB controller IP and the PHY device which drives the physical USB bus. Use of the ULPI standard reduces the interface pin count between the USB controller IP and the PHY device.

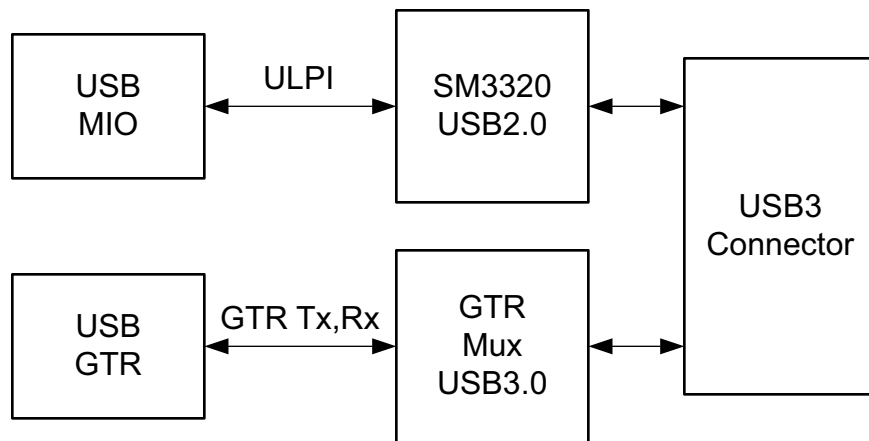

X16524-122118

Figure 3-3: USB Interface

The USB3320 is clocked by a 24 MHz crystal. Consult the Standard Microsystems Corporation (SMSC) USB3320 data sheet for clocking mode details [Ref 21].

The interface to the USB3320 PHY is implemented through the IP in the XCZU9EG MPSoC Processor System (PS).

Table 3-7 describes the jumper settings for the USB 2.0 circuit. The default shunt positions are set for Device mode.

Table 3-7: USB Jumper Settings

Header	Function	Shunt Position	Shunt Position	Shunt Position	Notes
		Device Mode	Host Mode	OTG Mode	
J7	V _{BUS} 5V supply	OFF	ON	ON	Shunt ON = Host or OTG mode Shunt OFF = Device mode
J109	Cable ID select	2-3	2-3	1-2	Position 1-2 = A/B cable detect Position 2-3 = ID not used
J110	CV _{BUS} select	1-2	2-3	1-2	Position 1-2 = OTG and Device mode (1 μF) Position 2-3 = Host mode (120 μF)
J112	USB J96 shield connection	1-2	1-2	1-2	Position 1-2 = Shield floating Position 2-3 = Shield connected to GND
J113	RV _{BUS} select	1-2	1-2	2-3	Position 1-2 = Host or Device mode (10 kΩ) Position 2-3 = OTG mode (1 kΩ)

The connections between the USB 2.0 PHY at U116 and the XCZU9EG MPSoC are listed in Table 3-8.

Table 3-8: USB 2.0 ULPI Transceiver Connections to the XCZU9EG MPSoC

XCZU9EG (U1) Pin	Net Name	USB3320 U116	
		Pin Number	Pin Name
U117.4 ⁽¹⁾	ULPI0_RST_B	27	RESET_B
G23	MIO58_USB_STP	29	STP
E23	MIO53_USB_DIR	31	DIR
F22	MIO52_USB_CLK	1	CLKOUT
B23	MIO55_USB_NXT	2	NXT
C23	MIO56_USB_DATA0	3	DATA0
A23	MIO57_USB_DATA1	4	DATA1
F23	MIO54_USB_DATA2	5	DATA2
B24	MIO59_USB_DATA3	6	DATA3
E24	MIO60_USB_DATA4	7	DATA4
C24	MIO61_USB_DATA5	9	DATA5
G24	MIO62_USB_DATA6	10	DATA6
D24	MIO63_USB_DATA7	13	DATA7

Notes:

1. PS_POR_B (U1.V23) or PS_MODE1 (DIP SW6.2) or PB SW2 drive U116 RST_B via OR gate U117.

Note that the shield for the USB 3.0 micro-B connector (J96) can be tied to GND by a jumper on header J112 pins 2-3. The USB shield can optionally be connected through a capacitor to GND by installing a capacitor (body size 0402) at location C887 and jumping pins 1-2 on header J112.

The USB3320 ULPI U116 transceiver circuit (see [Figure 3-4](#)) has a Micrel MIC2544 high-side programmable current limit switch (U121). This switch has an open-drain output fault flag on pin 2, which will turn on LED DS51 if overcurrent or thermal shutdown conditions are detected. DS51 is located in the U116 circuit area near push-button SW2 ([Figure 2-1](#), callout 5).

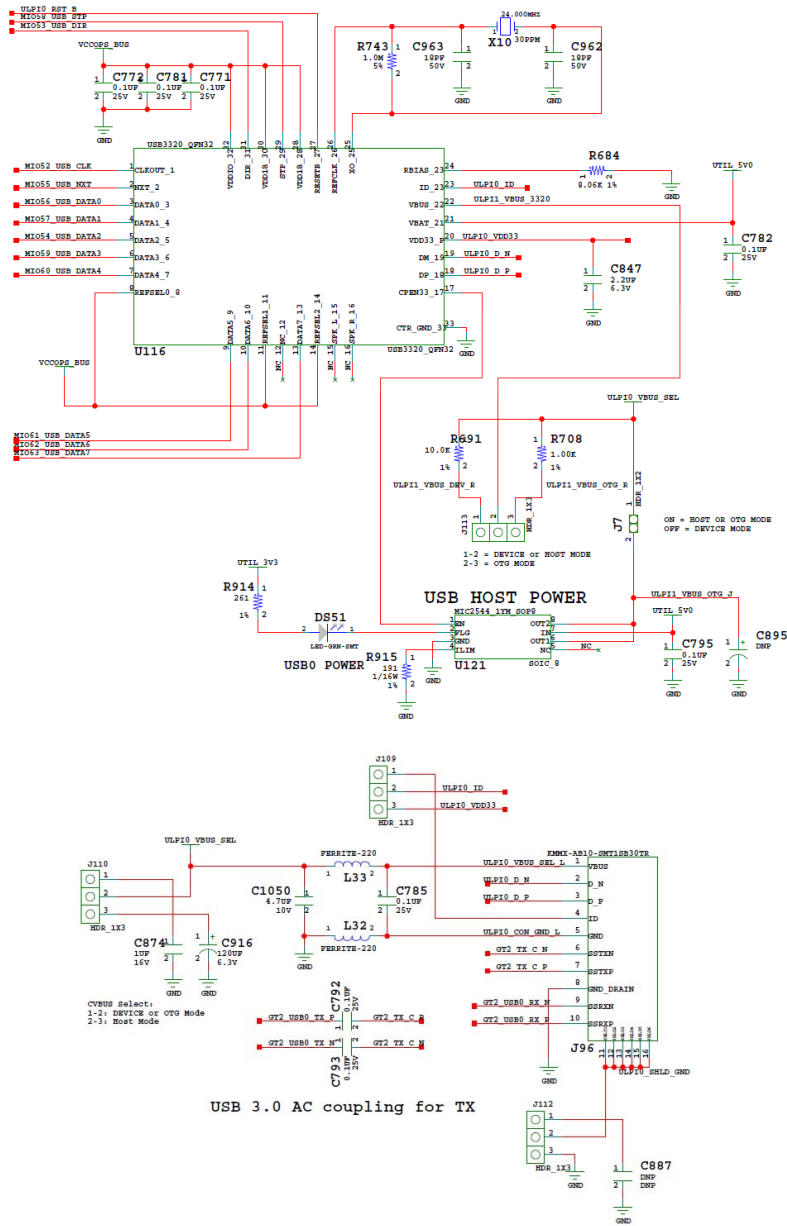

Figure 3-4: ULPI U116 Transceiver Circuit

SD1 (MIO 39-51)

A PS-side interface to an SD card connector is provided for booting and file system storage. This interface is used for the SD boot mode and supports SD3.0 access post boot.

SD Card Interface

[Figure 2-1, callout 6]

The ZCU102 board includes a secure digital input/output (SDIO) interface to provide access to general purpose non-volatile SDIO memory cards and peripherals. Information for the SD I/O card specification can be found at the SanDisk Corporation [Ref 22] or SD Association [Ref 23] websites. The ZCU102 SD card interface supports the SD1_LS configuration boot mode documented in the *Zynq UltraScale+ MPSoC Technical Reference Manual* (UG1085) [Ref 3].

The SDIO signals are connected to XCZU9EG MPSoC PS bank 501 which has its V_{CCMIO} set to 1.8V. Each of the six MIOxx_SDIO_* nets has a series 30 ohm resistor at the source. An NXP IP4856CX25 SD 3.0-compliant voltage level-translator U133 is present between the XCZU9EG MPSoC and the SD card connector (J100). The NXP IP4856CX25 U133 device provides SD3.0 capability with SDR104 performance. The NXP SD3.0 level shifter is mounted on an Aries adapter board that has the pin mapping shown in Table 3-9.

Table 3-9: U133 IP4856CX25 Adapter Pin-Out

Aries Adapter Pin Number	IP4856CX25 U133 Pin Number	IP4856CX25 U133 Pin Name
1	C1	CLK_IN
2	C3	GND
3	D3	CD
4	D2	CMD_H
5	E2	CLK_FB
6	E4	WP
7	B4	VLDO
8	C4	V_{SD_REF}
9	A3	DIR_0
10	A4	V_{SUPPLY}
11	B3	V_{CCA}
12	A2	DIR_CMD
13	D1	DATA0_H
14	B2	SEL
15	B1	DATA3_H
16	E1	DATA1_H
17	E3	DIR_1_3
18	A1	DATA2_H
19	E5	DATA1_SD
20	D5	DATA0_SD

Table 3-9: U133 IP4856CX25 Adapter Pin-Out (Cont'd)

Aries Adapter Pin Number	IP4856CX25 U133 Pin Number	IP4856CX25 U133 Pin Name
21	C5	CLK_SD
22	D4	CMD_SD
23	B5	DATA3_SD
24	A5	DATA2_SD
25	C2	ENABLE

Figure 3-5 shows the connections of the SD card interface on the ZCU102 board.

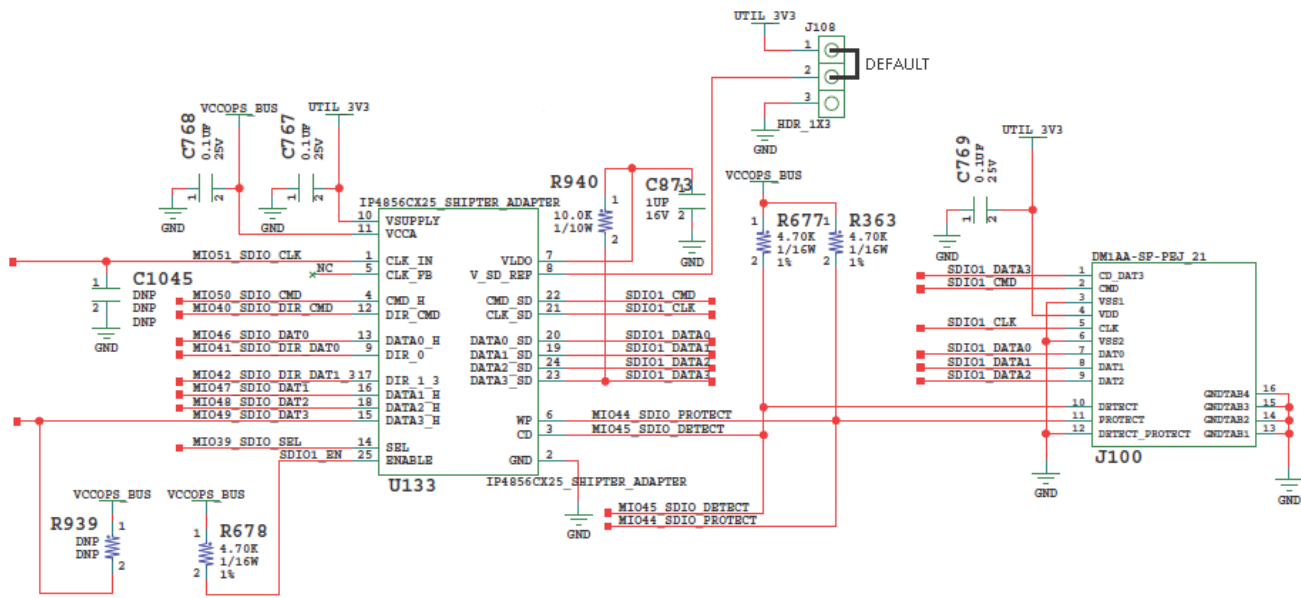

X16378-071817

Figure 3-5: SD Card Interface

Table 3-10 lists the SD card interface connections to the XCZU9EG MPSoC.

Table 3-10: SD Interface Connections to the XCZU9EG MPSoC

XCZU9EG (U1) Pin	Net Name	U133 IP4856CX25 Adapter	
		Pin Number	Pin Name
N23	MIO39_SDIO_SEL	14	SEL
M23	MIO40_SDIO_DIR_CMD	12	DIR_CMD
J24	MIO41_SDIO_DIR_DAT0	9	DIR_0
M24	MIO42_SDIO_DIR_DAT1_3	17	DIR_1_3
J25	MIO46_SDIO_DAT0	13	DATA0_H
L25	MIO47_SDIO_DAT1	16	DATA1_H
M25	MIO48_SDIO_DAT2	18	DATA2_H
K25	MIO49_SDIO_DAT3	15	DATA3_H
P25	MIO50_SDIO_CMD	4	CMD_H
N25	MIO51_SDIO_CLK	1	CLK_IN
N24	MIO44_SDIO_PROTECT	6	WP
P24	MIO45_SDIO_DETECT	3	CD

Programmable Logic JTAG Programming Options

[Figure 2-1, callouts 7 and 39]

ZCU102 JTAG chain:

- J2 USB micro AB connector connected to U21 Digilent USB JTAG
- J8 2x7 2 mm shrouded, keyed JTAG pod flat cable connector
- J6 2x10 Arm JTAG male pin header

The ZCU102 board JTAG chain is shown in Figure 3-6.

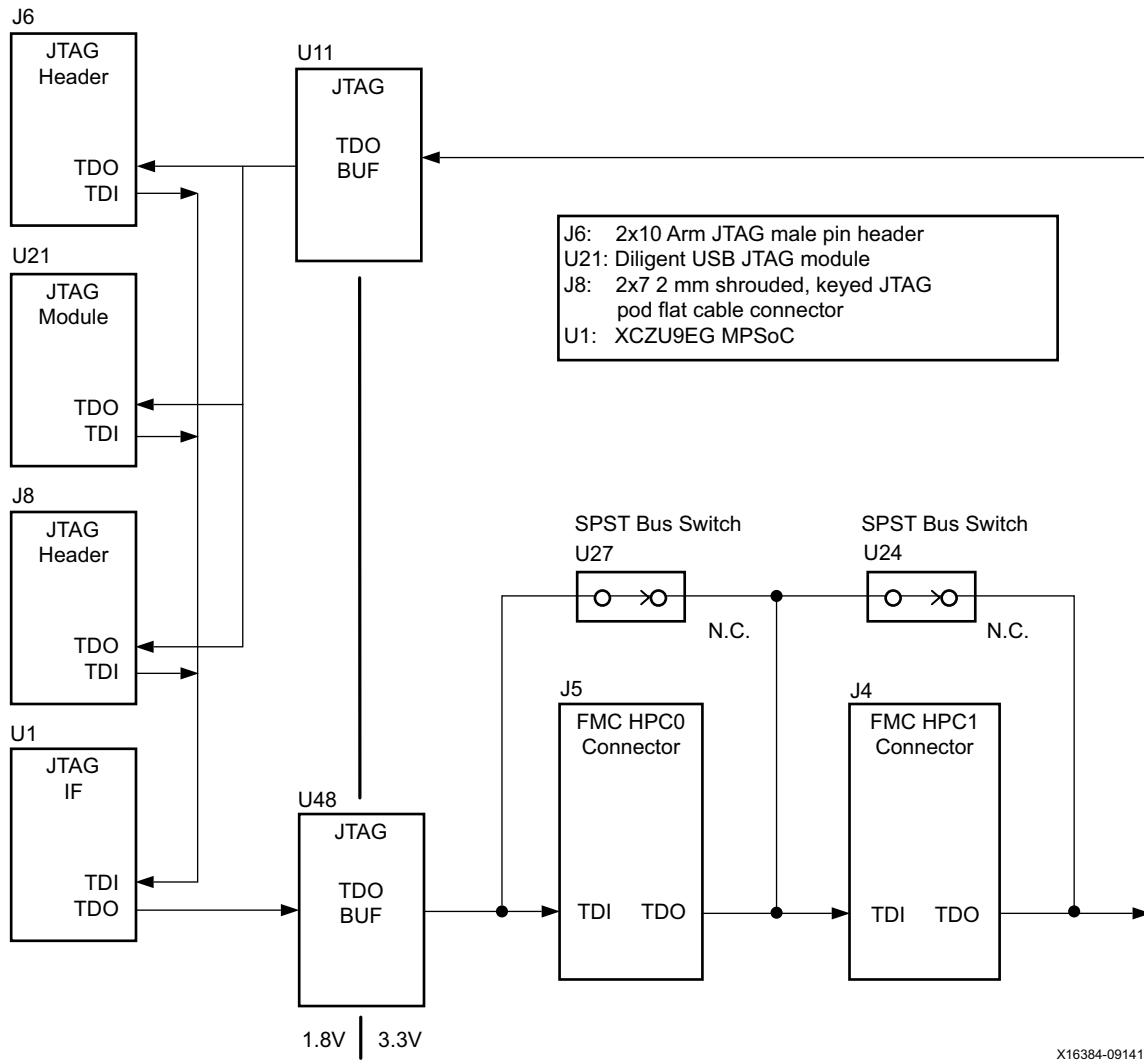

Figure 3-6: JTAG Chain Block Diagram

FMC Connector JTAG Bypass

When an FPGA mezzanine card (FMC) is attached to J5 or J4 it is automatically added to the JTAG chain through electronically controlled single-pole single-throw (SPST) switches U27 and U24. The SPST switches are normally closed and transition to an open state when an FMC is attached. Switch U27 adds an attached FMC to the JTAG chain as determined by the FMC_HPC0_PRSENT_M2C_B signal. Switch U24 adds an attached FMC to the JTAG chain as determined by the FMC_HPC1_PRSENT_M2C_B signal. The attached FMC card must implement a TDI-to-TDO connection using a device or bypass jumper to ensure that the JTAG chain connects to the XCZU9EG MPSoC.

EMIO Arm Trace Port

[Figure 2-1, callout 43]

The ZCU102 evaluation board provides a trace/debug 38-pin Mictor connector, P6. Figure 3-7 shows connector P6 with its MPSoC Bank 47/48 connections.

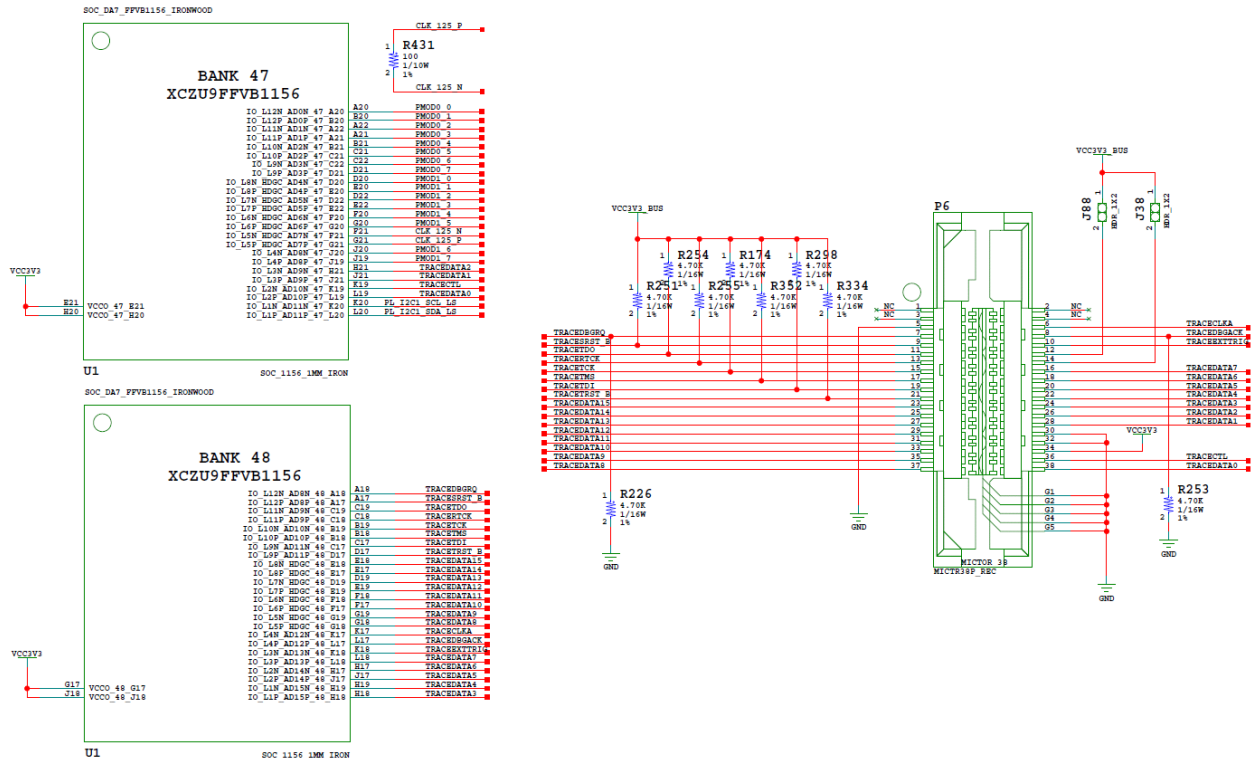

Figure 3-7: EMIO Arm Trace Port Interface

The P6 connector to MPSoC connections are listed in Table 3-11.

Table 3-11: Trace/Debug Conn. P6 Connections to the XCZU9EG MPSoC

XCZU9EG (U1) Pin	Schematic Net Name	I/O Standard	Trace/Debug P6 Pin
L19	TRACEDATA0	LVC MOS33	38
J21	TRACEDATA1	LVC MOS33	28
H21	TRACEDATA2	LVC MOS33	26
H18	TRACEDATA3	LVC MOS33	24
H19	TRACEDATA4	LVC MOS33	22
J17	TRACEDATA5	LVC MOS33	20
H17	TRACEDATA6	LVC MOS33	18
L18	TRACEDATA7	LVC MOS33	16

Table 3-11: Trace/Debug Conn. P6 Connections to the XCZU9EG MPSoC (Cont'd)

XCZU9EG (U1) Pin	Schematic Net Name	I/O Standard	Trace/Debug P6 Pin
G18	TRACEDATA8	LVC MOS33	37
G19	TRACEDATA9	LVC MOS33	35
F17	TRACEDATA1	LVC MOS33	33
F18	TRACEDATA11	LVC MOS33	31
E19	TRACEDATA12	LVC MOS33	29
D19	TRACEDATA13	LVC MOS33	27
E17	TRACEDATA14	LVC MOS33	25
E18	TRACEDATA15	LVC MOS33	23
K17	TRACECLKA	LVC MOS33	6
C18	TRACERTCK	LVC MOS33	13
A18	TRACEDBGRQ	LVC MOS33	7
L17	TRACEDBGACK	LVC MOS33	8
K19	TRACECTL	LVC MOS33	36
K18	TRACEEXTTRIG	LVC MOS33	10
B19	TRACETCK	LVC MOS33	15
C17	TRACETDI	LVC MOS33	19
C19	TRACETDO	LVC MOS33	11
B18	TRACETMS	LVC MOS33	17
D17	TRACETRST_B	LVC MOS33	21
A17	TRACESRST_B	LVC MOS33	9

For more information about managing the Zynq MPSoC extended MIO (EMIO) trace port connections refer to the *Zynq UltraScale+ MPSoC Technical Reference Manual (UG1085)* [Ref 3].

Clock Generation

The ZCU102 board provides fixed and variable clock sources for the XCZU9EG MPSoC. [Table 3-12](#) lists the source devices for each clock.

Table 3-12: ZCU102 Board Clock Sources

Clock Name	Frequency	Clock Source
Fixed Frequency Clocks		
PS_REF_CLK	33.33 MHz	U69 SI5341B Clock Generator
CLK_74_25	74.25 MHz	
CLK_125	125 MHz	
GTR_REF_CLK_PCIE	100 MHz	
PCIE_SLOT_CLK	100 MHz	
GTR_REF_CLK_SATA	125 MHz	
GTR_REF_CLK_USB3	26 MHz	
GTR_REF_CLK_DP	27 MHz	
Programmable Frequency Clocks		
USER_SI570	300 MHz (Default)	U42 SI570 I2C PROG. OSC.
USER_MGT_SI570	156.2 MHz (Default)	U56 SI570 I2C PROG. OSC.
USER_MGT_SMA	User-Provided Source	J79 (P)/J80 (N) SMA CONN.
HDMI_SI5324_OUT	Variable	U108 Clock Recovery
SFP_SI5328_OUT	Variable	U20 Clock Recovery

[Table 3-13](#) lists the source devices for each clock.

Table 3-13: Clock Connections, Source to XCZU9EG MPSoC

Clock Source Ref. Des. and Pin	Schematic Net Name	I/O Standard	FPGA (U1) Pin
U69.59	PS_REF_CLK	(1)	U24
U69.45	CLK_125_P	LVDS_25	G21
U69.44	CLK_125_N	LVDS_25	F21
U69.51	CLK_74_25_P	LVDS_25	AK15
U69.50	CLK_74_25_N	LVDS_25	AK14
U69.38	PCIE_SLOT_CLK_P	N/A	(PCIE CONNECTOR) P1.A13
U69.37	PCIE_SLOT_CLK_N	N/A	(PCIE CONNECTOR) P1.A14
U69.42	GTR_REF_CLK_PCIE_P	(2)	AA27
U69.41	GTR_REF_CLK_PCIE_N	(2)	AA28

Table 3-13: Clock Connections, Source to XCZU9EG MPSoC (Cont'd)

Clock Source Ref. Des. and Pin	Schematic Net Name	I/O Standard	FPGA (U1) Pin
U69.35	GTR_REF_CLK_SATA_P	(2)	W27
U69.34	GTR_REF_CLK_SATA_N	(2)	W28
U69.31	GTR_REF_CLK_USB3_P	(2)	U27
U69.30	GTR_REF_CLK_USB3_N	(2)	U28
U69.24	GTR_REF_CLK_DP_P	(2)	U31
U69.23	GTR_REF_CLK_DP_N	(2)	U32
U42.4	USER_SI570_P	DIFF_SSTL12	AL8
U42.5	USER_SI570_N	DIFF_SSTL12	AL7
U56.4	USER_MGT_SI570_P	(2)	(1-to-2 CLOCK BUFFER) U51.6
U56.5	USER_MGT_SI570_N	(2)	(1-to-2 CLOCK BUFFER) U51.7
U51.11	USER_MGT_SI570_CLOCK1_P	(2)	L27
U51.12	USER_MGT_SI570_CLOCK1_N	(2)	L28
U51.13	USER_MGT_SI570_CLOCK2_P	(2)	C8
U51.14	USER_MGT_SI570_CLOCK2_N	(2)	C7
J79.1	USER_SMA_MGT_CLOCK_P	(2)	N27
J80.1	USER_SMA_MGT_CLOCK_N	(2)	N28
U108.28	HDMI_SI5324_OUT_P	(2)	R27
U108.29	HDMI_SI5324_OUT_N	(2)	R28
U20.28	SFP_SI5328_OUT_P	(2)	B10
U20.29	SFP_SI5328_OUT_N	(2)	B9

Notes:

1. U1 XCZU9EG Bank 503 supports LVCMOS level inputs.
2. U1 MGT (I/O standards do not apply).

SI5341B 10 Independent Output Any-Frequency Clock Generator (PS Reference Clock)

[Figure 2-1, callout 10]

- Clock generator: Silicon Labs SI5341B-B05071-GM
- Jitter: <100 fs RMS typical
- Differential and single-ended outputs

The SI5341B is a one-time programmable clock source. For more details refer to the SI5341B data sheet [Ref 24] for more details. The clock circuit is shown in Figure 3-8.

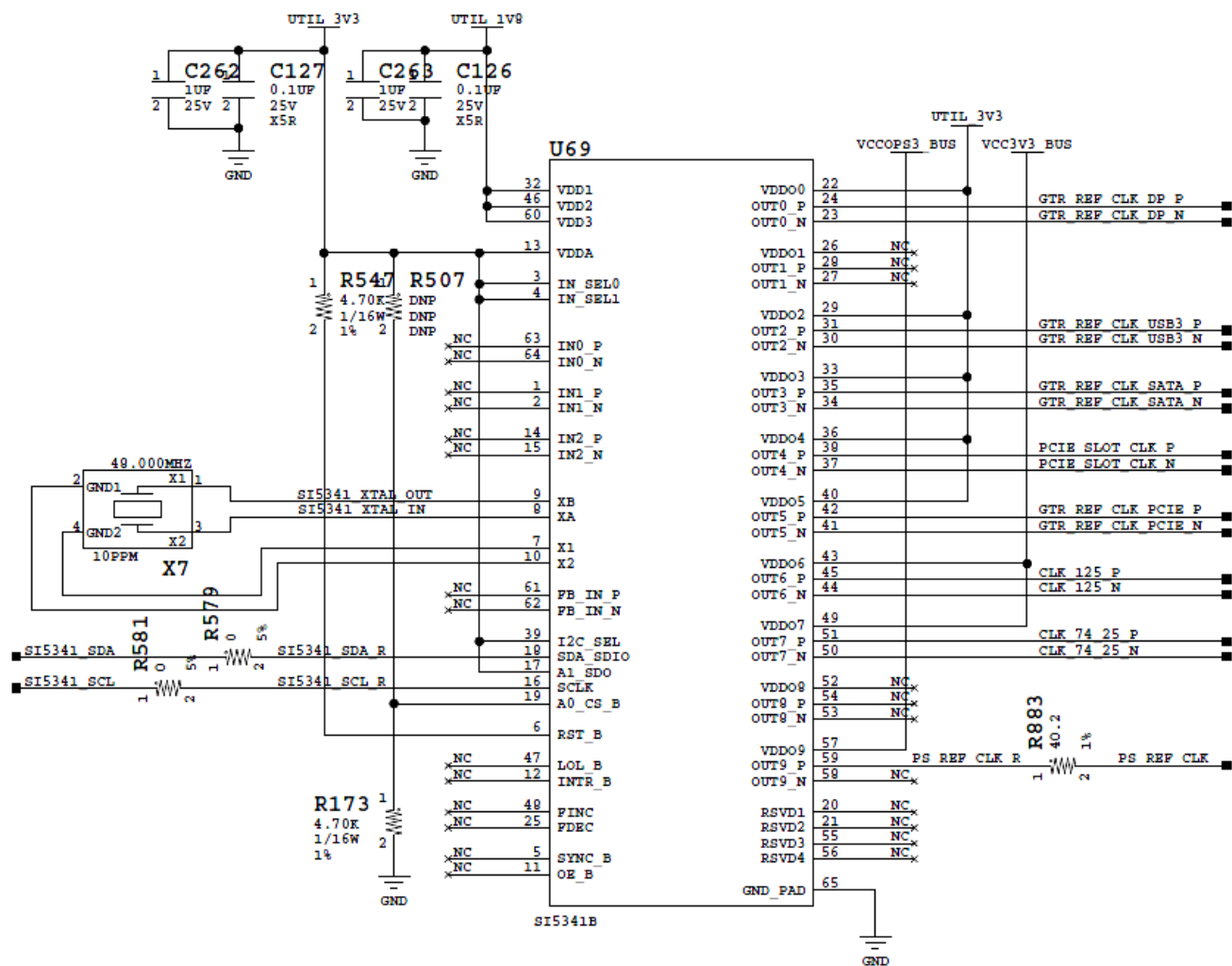

X16386-071817

Figure 3-8: SI5341B Clock Generator

Programmable User Clock

[Figure 2-1, callout 8]

The ZCU102 board has an I2C programmable SI570 low-jitter 3.3V LVDS differential oscillator (U42) connected to the GC inputs of PL bank 64. This USER_SI570_P and USER_SI570_N clock signal pair is connected to XCZU9EG MPSoC U1 pins AL8 and AL7 respectively. On power-up the user clock defaults to an output frequency of 300.000 MHz. User applications can change the output frequency within the range of 10 MHz to 810 MHz through an I2C interface. Power cycling the ZCU102 board reverts this user clock to the default frequency of 300.000 MHz.

This oscillator can be reprogrammed from MSP430 system controller U41 (see [TI MSP430 System Controller](#) for more information).

- Programmable oscillator: Silicon Labs Si570BAB001614DG (10 MHz-810 MHz)
- LVDS differential output
- Total Stability: 61.5 ppm

The user clock circuit is shown in [Figure 3-9](#). The Silicon Labs Si570 and Si53340 data sheets are available on the Silicon Labs website [\[Ref 24\]](#).

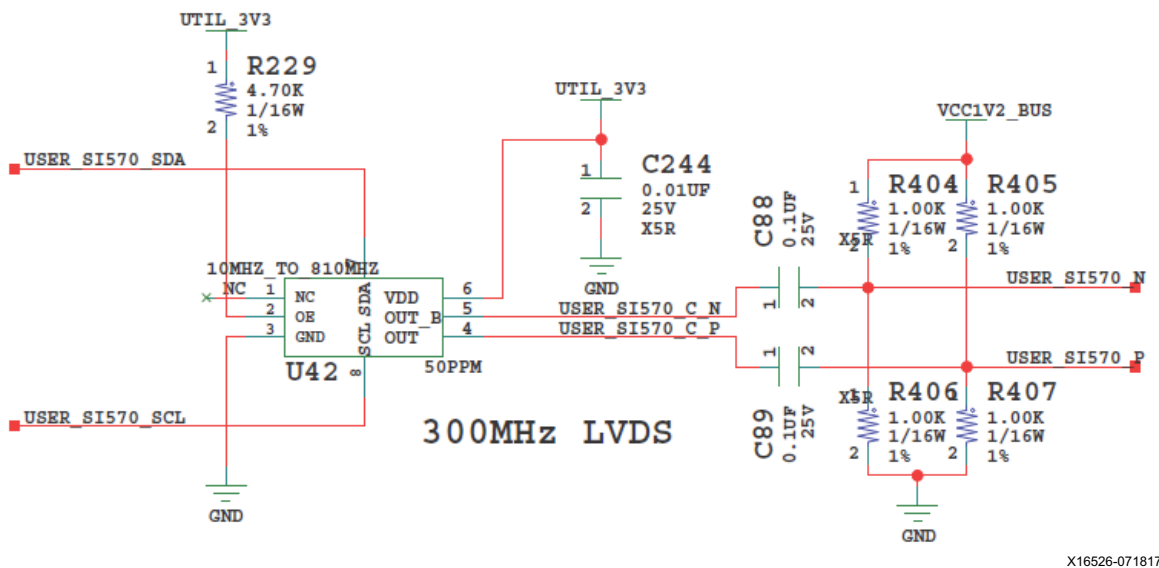

X16526-071817

Figure 3-9: Programmable User Clock

Programmable User MGT Clock

[Figure 2-1, callout 9]

The ZCU102 board has a programmable low-jitter 3.3V LVDS SI570 differential oscillator (U56) connected to a 1-to-2 SI53340 clock driver (U51). On power-up the user clock defaults to an output frequency of 156.250 MHz. User applications can change the output frequency within the range of 10 MHz to 810 MHz through an I2C interface. Power cycling the ZCU102 board reverts this user clock to the default frequency of 156.250 MHz.

This oscillator can be reprogrammed from MSP430 system controller U41 (see [TI MSP430 System Controller](#) for more information).

- Programmable oscillator: Silicon Labs Si570BAB000544DG (10 MHz-810 MHz)
- LVDS differential output
- Total stability: 61.5 ppm

The user clock MGT circuit is shown in [Figure 3-10](#). The Silicon Labs Si570 and Si53340 data sheets are available on the Silicon Labs website [[Ref 24](#)].

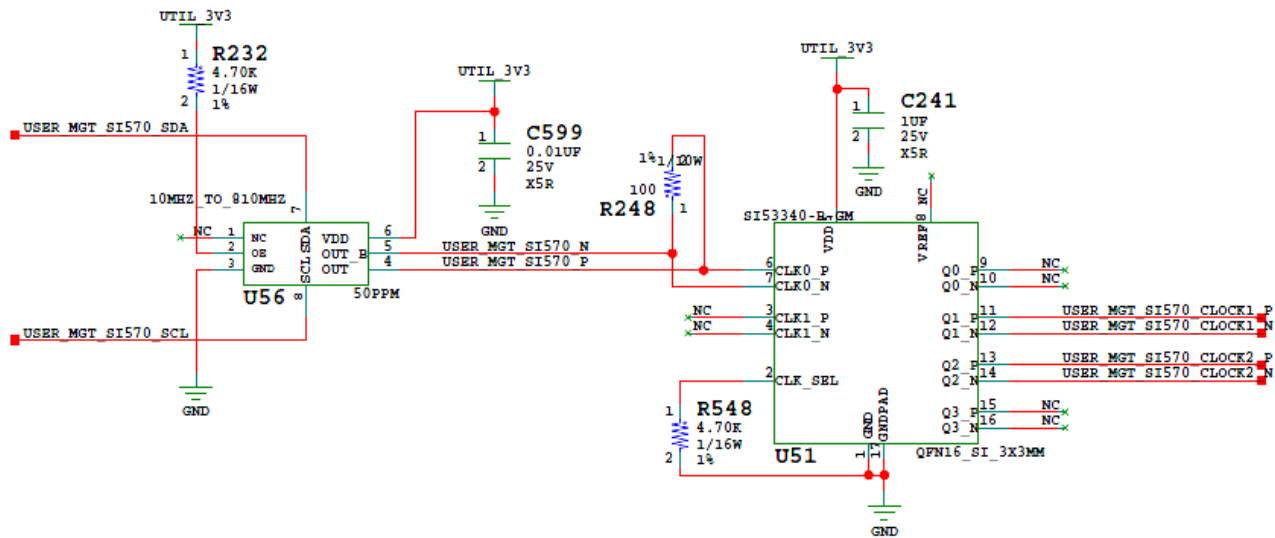

X16379-071817

Figure 3-10: Programmable User MGT Clock

User SMA MGT Clock

[Figure 2-1, callout 42]

The ZCU102 board provides a pair of SMAs for differential AC coupled user MGT clock input into FPGA U1 MGTH bank 129. This differential signal pair is series-capacitor coupled. The P-side SMA J79 signal USER_SMA_MGT_CLOCK_P is connected to U1 MGTREFCLK0P pin J27, with the N-side SMA J80 signal USER_SMA_MGT_CLOCK_N connected to U1 MGTREFCLK0N pin J28. The user SMA MGT clock circuit is shown in Figure 3-11.

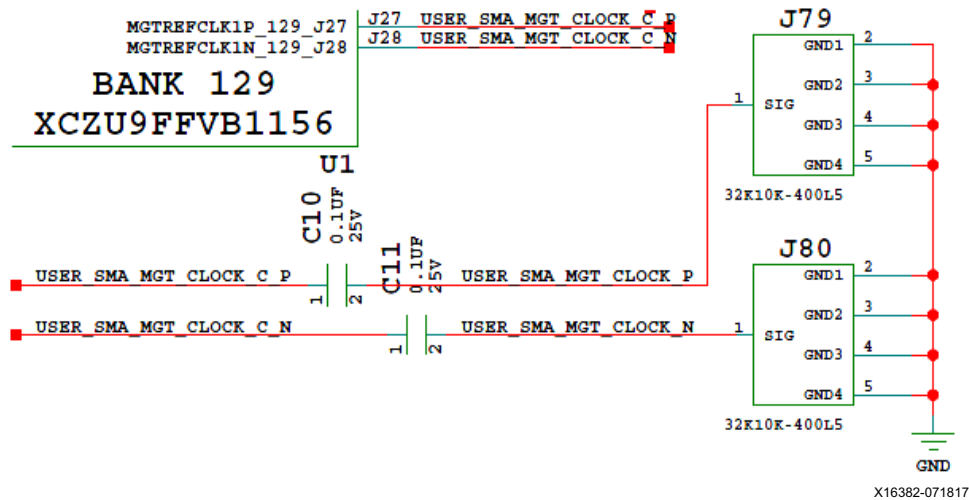
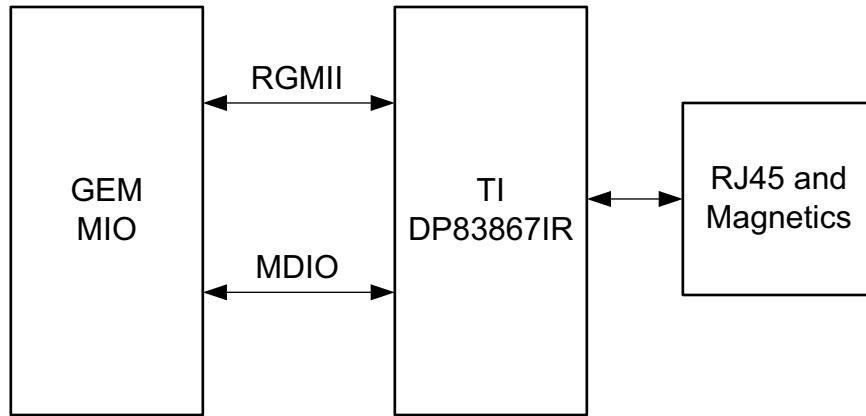

Figure 3-11: User SMA MGT Clock

GEM3 Ethernet (MIO 64-77)

[Figure 2-1, callout 12]

The PS-side Gigabit Ethernet MAC (GEM) implements a 10/100/1000 Mb/s Ethernet interface, shown in Figure 3-12, which connects to a TI DP83867IRPAP Ethernet RGMII PHY before being routed to an RJ45 Ethernet connector. The RGMII Ethernet PHY is boot strapped to PHY address 5'b01100 (0x0C) and Auto Negotiation set to *Enable*. Communication with the device is covered in the DP83867 RGMII PHY data sheet [Ref 25].



X16527-071817

Figure 3-12: Ethernet Block Diagram

10/100/1000 MHz Tri-Speed Ethernet PHY

[Figure 2-1, callout 12]

The ZCU102 board uses the TIDP83867IRPAP Ethernet RGMII PHY [Ref 25] at U98 for Ethernet communications at 10 Mb/s, 100 Mb/s, or 1000 Mb/s. The board supports RGMII mode only. The PHY connection to a user-provided Ethernet cable is through a Würth 7499111221A RJ-45 connector (P12) with built-in magnetics.

The Ethernet connections from XCZU9EG MPSoC U1 to the DP83867IRPAP PHY device at U98 are listed in Table 3-14.

Table 3-14: Ethernet Connections, XCZU9EG MPSoC to the PHY Device

XCZU9EG (U1) Pin	Schematic Net Name	DP83867 PHY U98	
		Pin	Name
A25	MIO64_ENET_TX_CLK	40	GTX_CLK
A26	MIO65_ENET_TX_D0	38	TX_DO
A27	MIO66_ENET_TX_D1	37	TX_D1
B25	MIO67_ENET_TX_D2	36	TX_D2
B26	MIO68_ENET_TX_D3	35	TX_D3
B27	MIO69_ENET_TX_CTRL	52	TX_EN_TX_CTRL
C26	MIO70_ENET_RX_CLK	43	RX_CLK
C27	MIO71_ENET_RX_D0	44	RX_DO
E25	MIO72_ENET_RX_D1	45	RX_D1
H24	MIO73_ENET_RX_D2	46	RX_D2
G25	MIO74_ENET_RX_D3	47	RX_D3
D25	MIO75_ENET_RX_CTRL	53	RX_DV_RX_CTRL

Table 3-14: Ethernet Connections, XCZU9EG MPSoC to the PHY Device (Cont'd)

XCZU9EG (U1) Pin	Schematic Net Name	DP83867 PHY U98	
		Pin	Name
H25	MIO76_ENET_MDC	20	MDC
F25	MIO77_ENET_MDIO	21	MDIO

Ethernet PHY Reset

The DP83867IRPAP PHY U98 reset circuit is shown in Figure 3-13. The DP83867IRPAP can be reset by the SW9 push-button (U59.6), the MAX16025 U22 MPSoC PS-side POR reset device (U59.1), or the I2C0 connected U97 TCA6416A I/O expander port P06 pin 10 (U59.3).

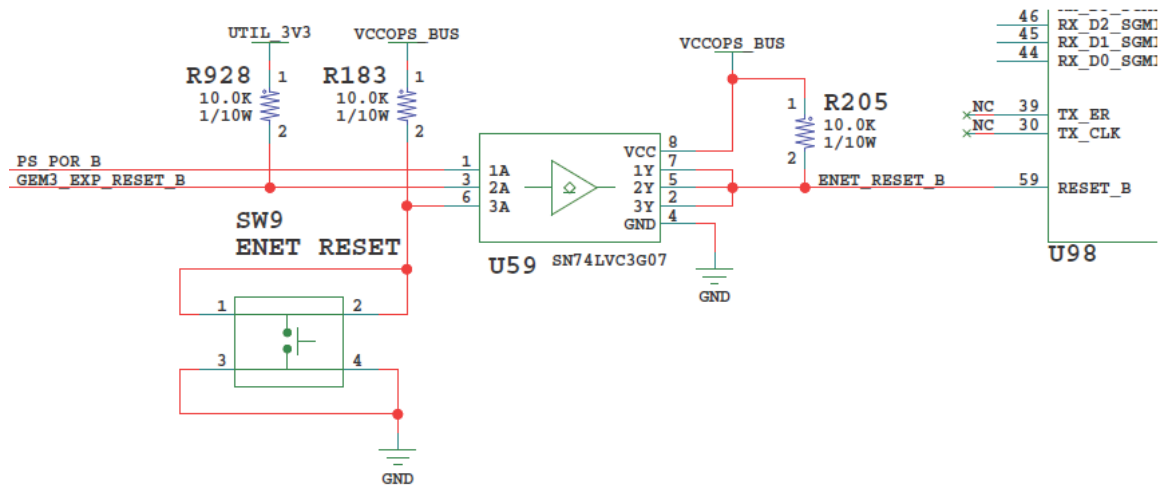

X16528-071817

Figure 3-13: Ethernet PHY Reset Circuit

Ethernet PHY LED Interface

[Figure 2-1, callout 12]

The DP83867IRPAP PHY U98 LED interface (LED_0, LED_2) uses the two LEDs embedded in the P12 RJ45 connector bezel. The LED functional description is show in [Table 3-15](#).

Table 3-15: Ethernet PHY LED Functional Description

Pin		Type	Description
Name	No.		
LED_2	61	S, I/O, PD	By default, this pin indicates receive or transmit activity. Additional functionality is configurable by means of LEDCR1[11:8] register bits. Note: This pin is a strap configuration pin for RGZ devices only.
LED_1	62	S, I/O, PD	By default, this pin indicates that 100BASE-T link is established. Additional functionality is configurable by means of LEDCR1[7:4] register bits.
LED_0	63	S, I/O, PD	By default, this pin indicates that link is established. Additional functionality is configurable by means of LEDCR1[3:0] register bits.

The LED functions can be re-purposed with a LEDCR1 register write available through the PHY's management Data Interface, MDIO/MDC. LED_2 is assigned to ACT (activity indicator) and LED_0 indicates link established. For more Ethernet PHY details, see the TI DS83867 data sheet [\[Ref 25\]](#).

CP2108 USB UART Interface

[Figure 2-1, callout 13]

The CP2108 quad USB-UART on the ZCU102 board provides four level-shifted UART connections through single micro-B USB connector J83. Channel 0 and 1 are PS-side MIO connections described in the MIO section. Channel 2 is a PL-side connection and Channel 3 is connected to MSP430 system controller U41. The USB UART interface circuit is shown in [Figure 3-14](#). The Silicon Labs CP2108 data sheet is available on the Silicon Labs website [\[Ref 24\]](#).

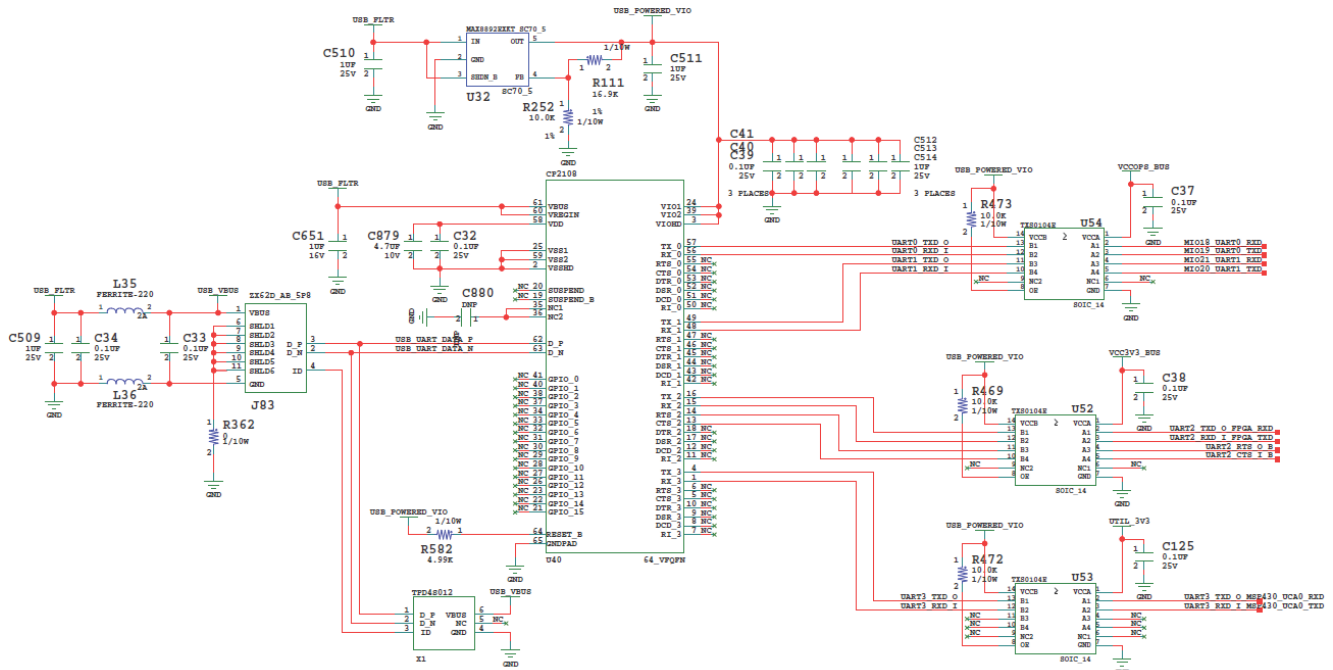

X16529-071817

Figure 3-14: USB UART Interface

CP2108 Channel 2 PL-Side UART Interface

The CP2108 channel 2 PL-side UART interface circuit is shown in Figure 3-15. The connections from XCZU9EG MPSoC U1 to CP2108 U40 via TSX0104E level shifter U52 are listed in Table 3-16.

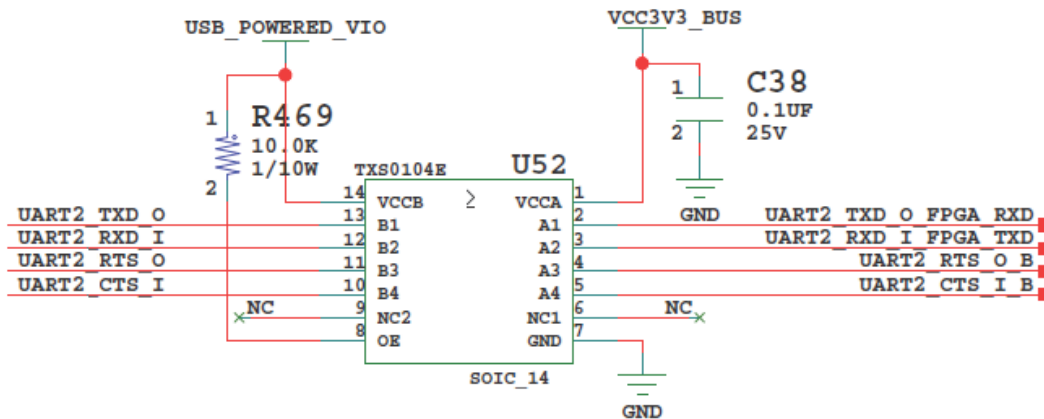

X16530-071817

Figure 3-15: PL-Side USB UART Interface

GPIO (MIO 13, 38)

These two (2) GPIO bits are connected to the U41 MSP430 system controller for general purpose signaling or communications between the Zynq UltraScale+ MPSoC and the MSP430 system controller. These signals are level-shifted by TSX0108E U141. The connections between the U41 system controller and the XCZU9EG MPSoC are listed in [Table 3-18](#).

Table 3-18: System Controller U41 GPIO Connections to XCZU9EG U1

XCZU9EG (U1) Pin	Net Name	MSP430 U41	
		Pin Name	Pin No.
AK17	MIO13_PS_GPIO2	20	P1_7
L23	MIO38_PS_GPIO1	19	P1_6

I2C0 (MIO 14-15)

I2C0 connects to MPSoC U1 PS Bank 500 and PL bank 50, and to system controller U41, as shown in [Figure 3-17](#). I2C0 connects to two GPIO 16-bit port expanders (TCA6416A U61 and U97) and an I2C SWITCH (PCA9544A U60) for controlling resets, GTR multiplexer settings, and power system enable pins, without requiring the PL-side to be configured. TCA6416A U97 is pin-strapped to respond to I2C address `0x20`, and U61 to `0x21`. The PCA9544A multiplexer is set to `0x75`.

The I2C0 bus also provides access to the PMBUS power controllers and PS-side and PL-side INA226 power monitors via the U60 PCA9544A bus switch. All PMBus controlled Maxim regulators are tied to the MAXIM_PMBUS, while the INA226 power monitors are separated on to PS_PMBUS and PL_PMBUS. [Figure 3-17](#) shows the I2C0 bus topology.

[Table 3-19](#) lists the I2C0 port expander TCA6416A U61 connections and [Table 3-20](#) the TCA6416A U97 connections. The devices on each bus of the I2C0 multiplexer U60 are identified in [Table 3-21](#) and the multiplexer bus connections are listed in [Table 3-22](#).

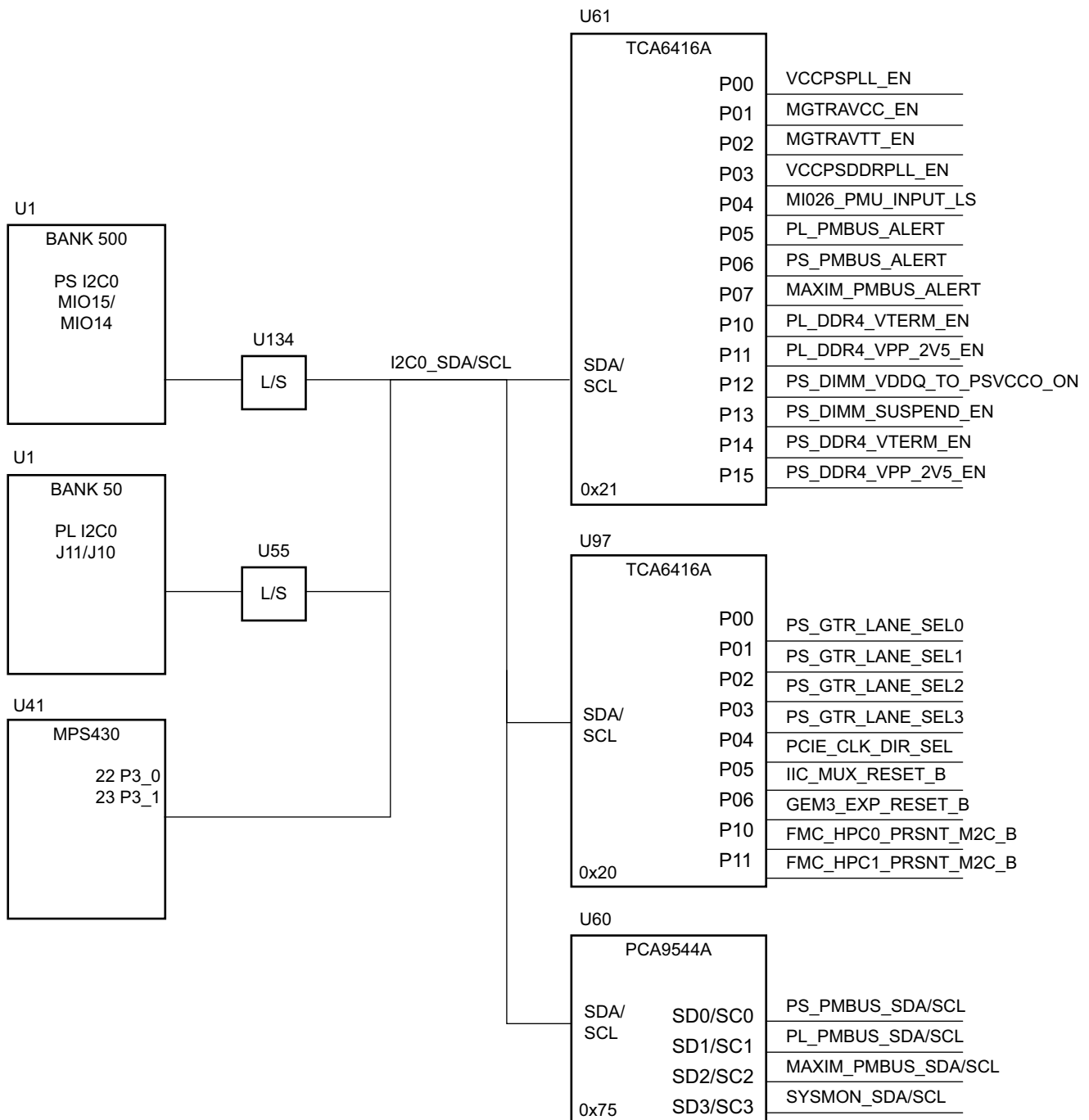

X16381-071817

Figure 3-17: I2C0 Bus Topology

Table 3-19: I2C0 Port Expander TCA6416A U61 Connections

TCA6416A U61		Schematic Net Name	Connected To			
Pin Name	Pin No.		Pin Name	Pin No.	Reference Designation	Device
SDA	23	I2C0_SDA	Refer to connections shown in Figure 3-17 . (TCA6416A U61 Addr. 0x21)			
SCL	22	I2C0_SCL				
P00	4	VCCPSPLL_EN	B	2	U140	SN74LVC1G08
P01	5	MGTRAVCC_EN	B	2	U112	SN74LVC1G08
P02	6	MGTRAVTT_EN	B	2	U130	SN74LVC1G08
P03	7	VCCPSDDRPLL_EN	B	2	U142	SN74LVC1G08
P04	8	MIO26_PMU_INPUT_LS	B	4	U147	SN74AVC1T45
P05	9	PL_PMBUS_ALERT	ALERT	3	U16, U65, U74, U75, U79, U80, U81, U84	INA226 Op amps
P06	10	PS_PMBUS_ALERT	ALERT	3	U15, U76, U77, U78, U87, U85, U86, U88, U92, U93	INA226 Op amps
P07	11	MAXIM_PMBUS_ALERT	ALERT	9, 11, 13	J84.7, U4, U8, U7, U9, U10, U13, U18, U46, U47, U49, U63, U95, U96	MAX15301:9, MAX15303:11, MAX20751:13
P10	13	PL_DDR4_VTERM_EN	EN	7	U35	TPS51200
P11	14	PL_DDR4_VPP2V5_EN	EN	5	U38	MAX15027
P12	15	PS_DIMM_VDDQ_TO_PSVCCO_ON	ON	C2	U57	TPS22924
P13	16	PS_DIMM_SUSPEND_EN	A	1	U26	SN74AUC1G32 OR-gate
P14	17	PS_DDR4_VTERM_EN	EN	7	U36	TPS51200
P15	18	PS_DDR4_VPP_2V5_EN	EN	5	U39	MAX15027

Table 3-20: I2C0 Port Expander TCA6416A U97 Connections

TCA6416A U97		Schematic Net Name	Connected To			
Pin Name	Pin No.		Pin Name	Pin No.	Reference Designation	Device
SDA	23	I2C0_SDA	Refer to connections shown in Figure 3-17 . (TCA6416A U97 Addr. 0x20)			
SCL	22	I2C0_SCL				
P00	4	PS_GTR_LANE_SEL0	SEL	3	U125	PI2DBS6212
P01	5	PS_GTR_LANE_SEL1	SEL	3	U126	PI2DBS6212
P02	6	PS_GTR_LANE_SEL2	SEL	3	U127	PI2DBS6212
P03	7	PS_GTR_LANE_SEL3	SEL	3	U128	PI2DBS6212
P04	8	PCIE_CLK_DIR_SEL	DIR	5	U139	SN74AVC1T45

Table 3-20: I2C0 Port Expander TCA6416A U97 Connections (Cont'd)

TCA6416A U97		Schematic Net Name	Connected To			
Pin Name	Pin No.		Pin Name	Pin No.	Reference Designation	Device
P05	9	IIC_MUX_RESET_B	RESET_B	3	U34, U135	TCA9548A
P06	10	GEM3_EXP_RESET_B	2A	3	U59	SN74LVC3G07
P10	13	FMC_HPC0_PRSNT_M2C_B	OE	4	U27, J5.H2	NC7SZ66, FMC0
P11	14	FMC_HPC1_PRSNT_M2C_B	OE	4	U24, J4.H2	NC7SZ66, FMC1

Table 3-21: I2C0 Multiplexer PCA9544A U60 (Addr. 0x75) Connections

U60 I2C Mux	MUX'd I2C Bus	Reference Designation	Device(s)
0	PS_PMBUS	U76, U77, U78, U87, U85, U86, U93, U88, U15, U92	INA226 Op amps
1	PL_PMBUS	U79, U81, U80, U84, U16, U65, U74, U75	INA226 Op amps
2	MAXIM_PMBUS	J84.3, U47, U7, U6, U10, U9, U63, U95, U96, U46, U4, U18, U13, U49	PMBUS connector, Voltage regulators
3	SYSMON	U135, U1	I2C1MUX, MPSoC

Table 3-22: I2C0 U60 (Addr. 0x75) Mux Target Bus Connections

Reference Designation	Address	Device(s)
PS_PMBUS		
U76	0X40	INA226 VCCPSINTFP
U77	0X41	INA226 VCCPSINTLP
U78	0X42	INA226 VCCPSAUX
U87	0X43	INA226 VCCPSPLL
U85	0X44	INA226 MGTRAVCC
U86	0X45	INA226 MGTRAVTT
U93	0X46	INA226 VCCO_PSDDR_504
U88	0X47	INA226 VCCOPS
U15	0X4A	INA226 VCCOPS3
U92	0X4B	INA226 VCCPSDDRPLL
PL_PMBUS		
U79	0X40	INA226 VCCINT
U81	0X41	INA226 VCCBRAM
U80	0X42	INA226 VCCAUX
U84	0X43	INA226 VCC1V2

Table 3-22: I2C0 U60 (Addr. 0x75) Mux Target Bus Connections (Cont'd)

Reference Designation	Address	Device(s)
U16	0X44	INA226 VCC3V3
U65	0X45	INA226 VADJ_FMC
U74	0X46	INA226 MGTAVCC
U75	0X47	INA226 MGTAVTT
MAXIM_PMBUS		
J84	N/A	PMBUS Conn SDA Pin 3/SCL Pin 1
U47	0X13	MAX15301 VCCINT
U7	0X14	MAX15303 VCCBRAM
U6	0X15	MAX15303 VCCAUX
U10	0X16	MAX15303 VCC1V2
U9	0X17	MAX15303 VCC3V3
U63	0X18	MAX15301 VADJ_FMC
U95	0X72	MAX20751 MGTAVCC
U96	0X73	MAX20751 MGTAVTT
U46	0X0A	MAX15301 VCCPSINTFP
U4	0X0B	MAX15303 VCCPSINTLP
U18	0X1D	MAX15303 DDR4_DIMM_VDDQ
U13	0X10	MAX15303 VCCOPS
U49	0X1A	MAX15301 UTIL_3V3
U8	0X1B	MAX15301 UTIL_5V0
SYSMON		
U1	N/A	U1 BANK 49 SDA Pin B14/SCL Pin C14
U135	N/A	TCA9548A Mux I2C1 Bus Port 2

I2C1 (MIO 16-17)

The PS-side I2C1 interface provides access to I2C peripherals through a set of I2C switches. The I2C connection is shared with the PL-side and the system controller. Figure 3-18 shows a high-level view of the I2C1 bus connectivity represented in Table 3-23 and Table 3-24. TCA9548A U34 is set to **0x74** and TCA9548A U135 is set to **0x75**.

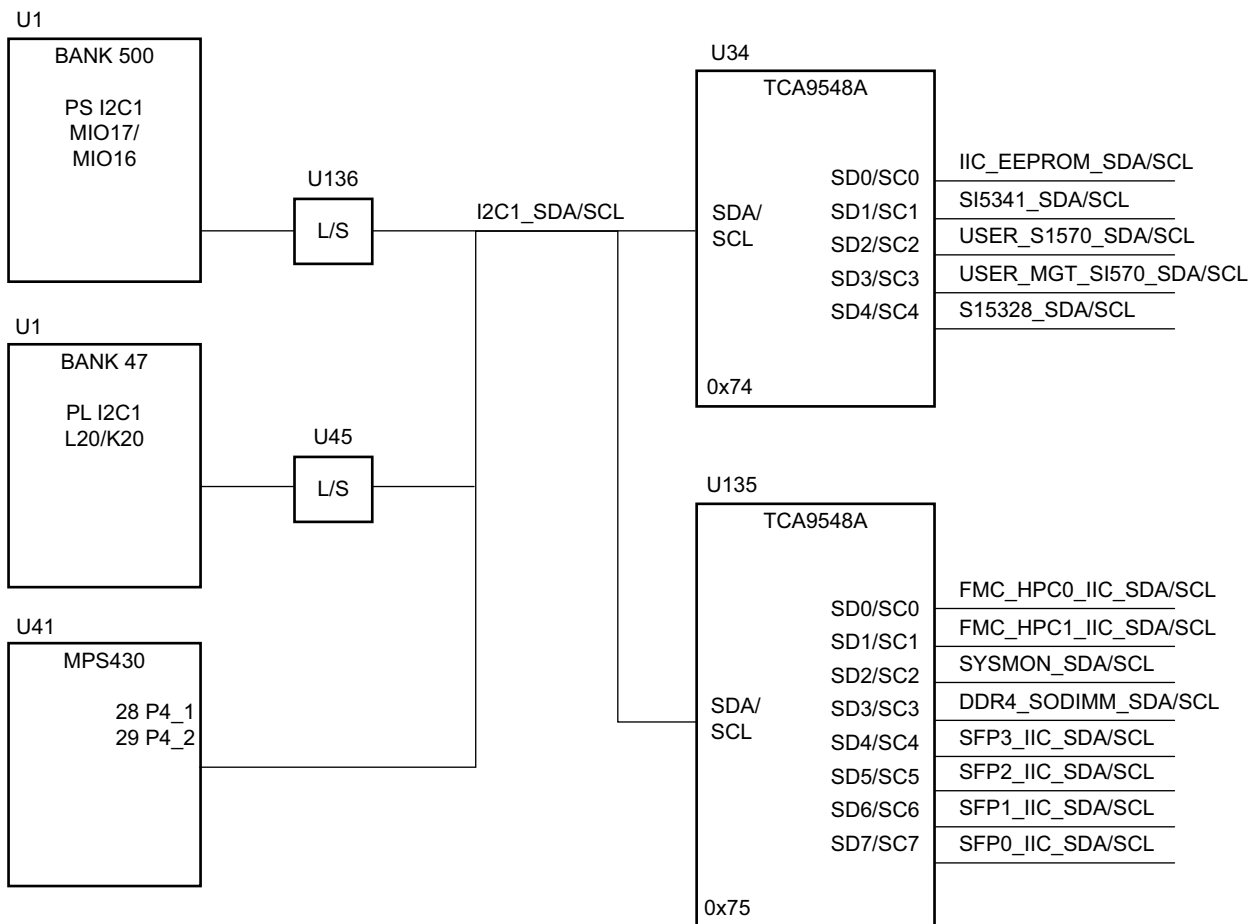

X16375-122118

Figure 3-18: I2C1 Bus Topology

Table 3-23: I2C1 TCA9548A U34 Multiplexer Connections

U34 I2C Mux (Addr 0x74) Port	I2C BUS 1 Device(s)	I2C Address
0	EEPROM U23	0x54
1	Si5341 clock U69	0x36
2	USER Si570 clock U42	0x5D
3	USER MGT Si570 clock U56	0x5D
4	Si5328 (clock recovery) U20	0x69

Table 3-23: I2C1 TCA9548A U34 Multiplexer Connections (Cont'd)

U34 I2C Mux (Addr 0x74) Port	I2C BUS 1 Device(s)	I2C Address
5	No connection	N/A
6	No connection	N/A
7	No connection	N/A

Table 3-24: I2C1 TCA9548A U135 Multiplexer Connections

U135 I2C Mux (Addr 0x75) Port	I2C BUS 1 Device(s)	I2C Address
0	FMC HPC_0	0x##
1	FMC HPC_1	0x##
2	SYSMON	0x32
3	DDR4 SODIMM	0x51
4	SFP_3	0x50
5	SFP_2	0x50
6	SFP_1	0x50
7	SFP_0	0x50

UART0 (MIO 18-19)

This is the primary Zynq UltraScale+ MPSoC PS-side UART interface and is connected to the U40 CP2108 USB-to-Quad-UART bridge with port assignments as listed in [Table 3-25](#). PS-side UART0 is accessed through the U40 CP2108 USB-to-Quad-UART bridge port 0.



IMPORTANT: Use SiLabs CP210X VCP driver version 6.7.0 or later for proper USB enumeration as identified in [Table 3-25](#).

Table 3-25: CP2108 UART Assignments

CP2108 U40	Zynq UltraScale+ MPSoC
UART0	PS_UART0 (MIO 18-19)
UART1	PS_UART1 (MIO 20-21)
UART2	PL-UART (HD Bank 49)
UART3	U41 System Controller UART

UART1 (MIO 20-21)

PS-side UART1 is accessed through the U40 CP2108 USB-to-Quad-UART Bridge port 1. The CP2108 Channel 1 PS-side UART interface circuit is shown in Figure 3-19. The connections from XCZU9EG U1 to CP2108 U40 via L/S U54 are listed in Table 3-26.

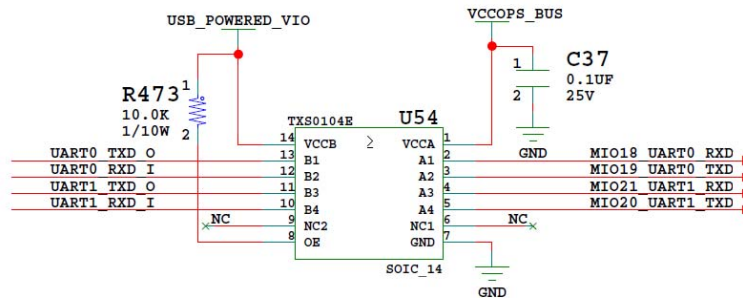

X16374-071817

Figure 3-19: CP2108 Channel 1 PS-Side UART Interface

Table 3-26: XCZU9EG U1 to CP2108 U40 Connections via L/S U54

XCZU9EG U1		Schematic Net Name	CP2108 U40	
Pin Name	Pin No.		Pin Name	Pin No.
PS_MIO18_AE18	AE18	MIO18_UART0_RXD	TX_0	57
PS_MIO19_AL17	AL17	MIO19_UART0_TXD	RX_0	56
PS_MIO21_AF18	AF18	MIO21_UART1_RXD	TX_1	49
PS_MIO20_AD18	AD18	MIO20_UART1_TXD	RX_1	48

GPIO (MIO 22-23)

PS-side pushbutton SW19 is connected to MIO22 (pin U1.AD20). PS-side LED DS50, placed next to the pushbutton, is connected to MIO23 (pin U1.AD19).

CAN1 (MIO 24-25)

The PS-side CAN bus TX and RX MIO pins go through TXS0104E level-translator U33 and TI SN65HVD232 CAN-bus transceiver U122 before being presented to the user on 0.1 inch centered 8-pin male header J98 (see [Figure 3-20](#) and [Figure 3-21](#)).

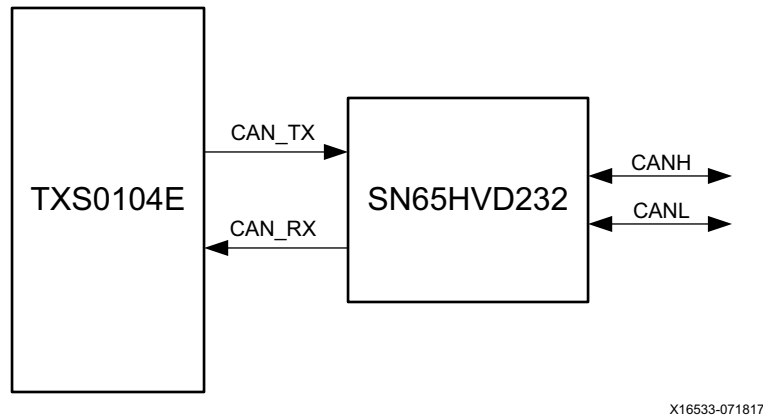

Figure 3-20: PS-Side CAN Bus Interface Diagram

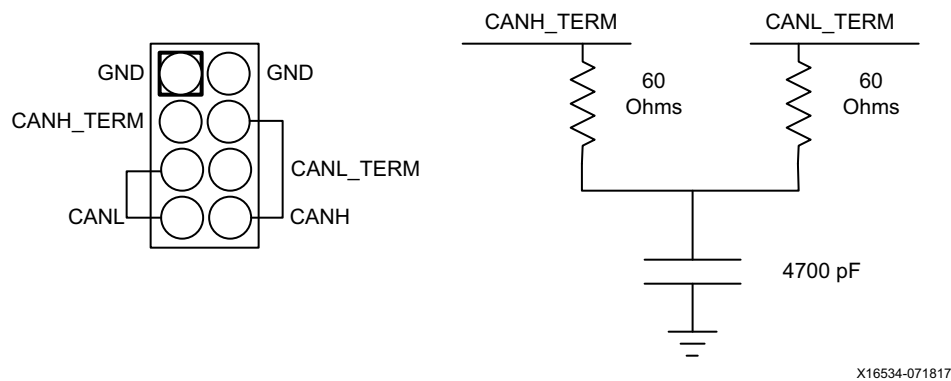

Figure 3-21: PS-Side Can Bus Interface Connector

PMU GPI (MIO 26)

PS-side MIO 26 is reserved as an input to the PMU for indicating a warm boot. PS bank 501 MIO26 (U1.P21) is connected to the I2C0 U61 TCA6416APWR bus expander (port P04 U61.8) through L/S U147 SN74AVC1T45. Refer the *Zynq UltraScale+ MPSoC Technical Reference Manual* (UG1085) [\[Ref 3\]](#) for more details about the PMU interface.

DPAUX (MIO 27-30)

The Zynq UltraScale+ MPSoC provides a VESA DisplayPort 1.2 source-only controller that supports up to two lanes of main link data at rates of 1.62 Gb/s, 2.70 Gb/s, or 5.40 Gb/s. The DisplayPort standard defines an auxiliary channel that uses LVDS signaling at a 1 Mb/s data rate, which is translated from single-ended MIO signals to the differential DisplayPort AUX channel, DPAUX (see [Table 3-27](#)). The DisplayPort circuit is shown in [Figure 3-22](#).

Table 3-27: DPAUX/MIO Connections

XCZU9EG (U1) Pin	Schematic Net Name	Level Shifter U114	
		Pin Name	Pin No.
L21	MIO30_DP_AUX_IN	2A1	8
K22	MIO29_DP_OE	1A2	7
N21	MIO28_DP_HPD	2A2	9
M21	MIO27_DP_AUX_OUT	1A1	6

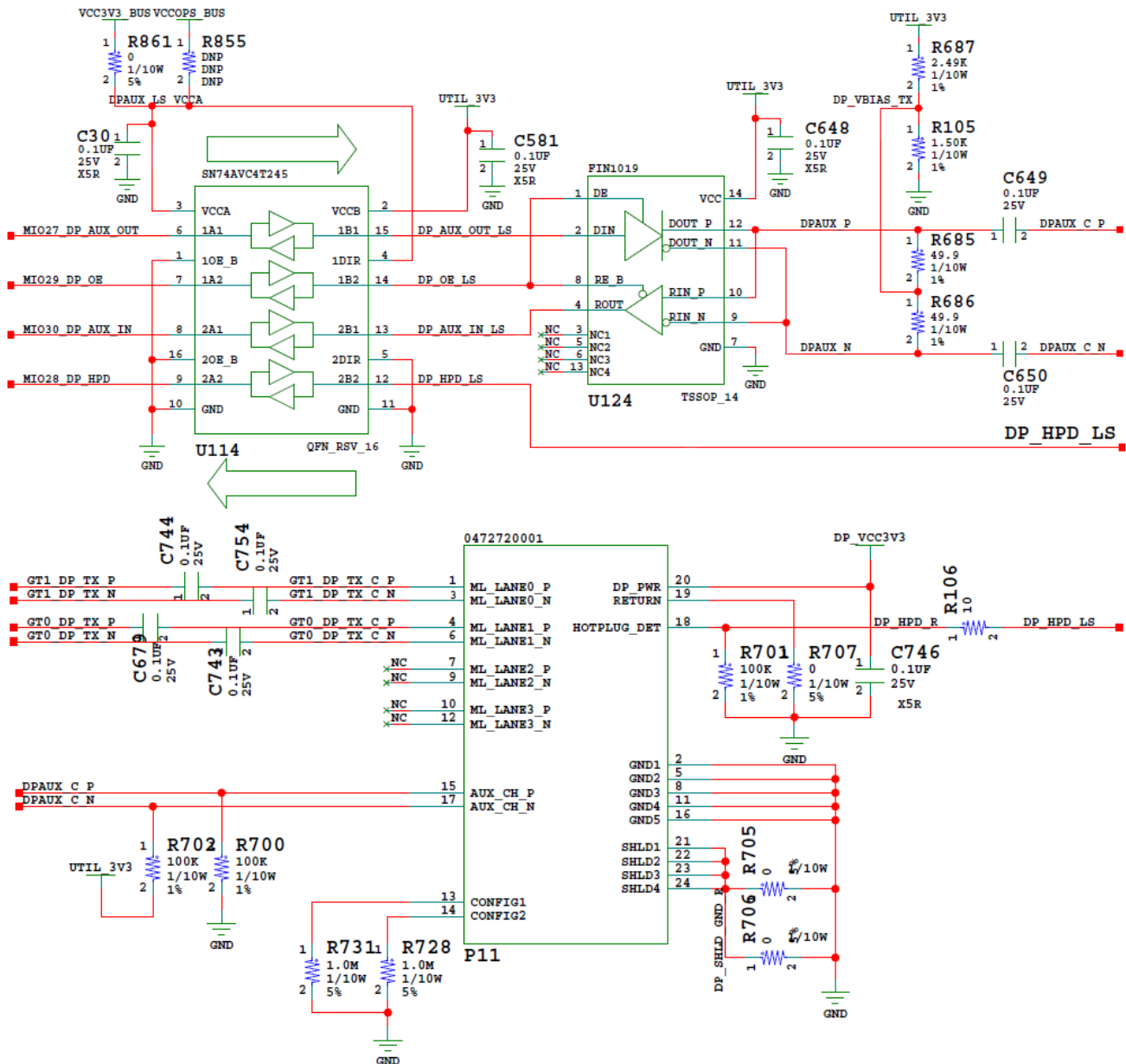

X16547-122118

Figure 3-22: DisplayPort Circuit

PCIe Reset (MIO 31)

The Zynq UltraScale+ MPSoC contains an integrated block for PCI Express interface based on the PCIe base v2.1 specification. The PS-side PCIe reset signal is wired to the PCIe Gen2 x4 root port slot P1. The MIO31 pin is an output for PCIe Root Port mode operation on the ZCU102.

PMU GPO (MIO 32-37)

The platform management unit (PMU) within the Zynq UltraScale+ MPSoC signals power domain changes using the PMU output pins for deep-sleep mode. The Zynq UltraScale+ MPSoC PMU GPO pins are connected to inputs of the MSP430 system controller via TXS0108E level-shifter U141. The connections from MPSoC U1 Bank 501 to MSP430 U41 are listed in [Table 3-28](#).

Table 3-28: XCZU9EG U1 to MSP430 Connections

XCZU9EG (U1) Pin	Schematic Net Name	MSP430 U41	
		Pin Name	Pin No.
N22	MIO37_PMU_GPO5	P1_0	13
K23	MIO36_PMU_GPO4	P1_1	14
P22	MIO35_PMU_GPO3	P1_2	15
L22	MIO34_PMU_GPO2	P1_3	16
H23	MIO33_PMU_GPO1	P1_4	17
H22	MIO32_PMU_GPO0	P1_5	18

Through the I2C0 Bus MPSoC MIO pins, the PMU has access to the board power controllers and power monitors. See [Figure 3-17](#) for more details.

Refer the *Zynq UltraScale+ MPSoC Technical Reference Manual* (UG1085) [\[Ref 3\]](#) for more details about the PMU interface.

HDMI Video Output

[\[Figure 2-1, callout 14\]](#)

The ZCU102 board provides a High-Definition Multimedia Interface (HDMI™) video output using a TI SN65DP159RGZ HDMI retimer at U94. The HDMI output is provided on a TE Connectivity 1888811-1 right-angle dual-stacked HDMI type-A receptacle at P7 (upper port). The SN65DP159RGZ device is a dual mode DisplayPort to transition-minimized differential signal (TMDS) retimer supporting digital video interface (DVI) 1.0 and HDMI 1.4b and 2.0 output signals. The SN65DP159RGZ device supports the dual mode standard version 1.1 type 1 and type 2 through the DDC link or AUX channel. The SN65DP159RGZ device supports data rates up to 6 Gb/s per data lane to support Ultra HD (4K x 2K / 60 Hz) 8-bits per color high-resolution video and HDTV with 16-bit color depth at 1080p (1920 x 1080 / 60 Hz). The SN65DP159RGZ device can automatically configure itself as a re-driver at data rates <1 Gb/s, or as a retimer at more than this data rate. This feature can be turned off through I2C programming.

The HDMI video transmit/receive block diagram is shown in [Figure 3-23](#). The connections between the codec and the XCZU9EG MPSoC are listed in [Table 3-29](#).

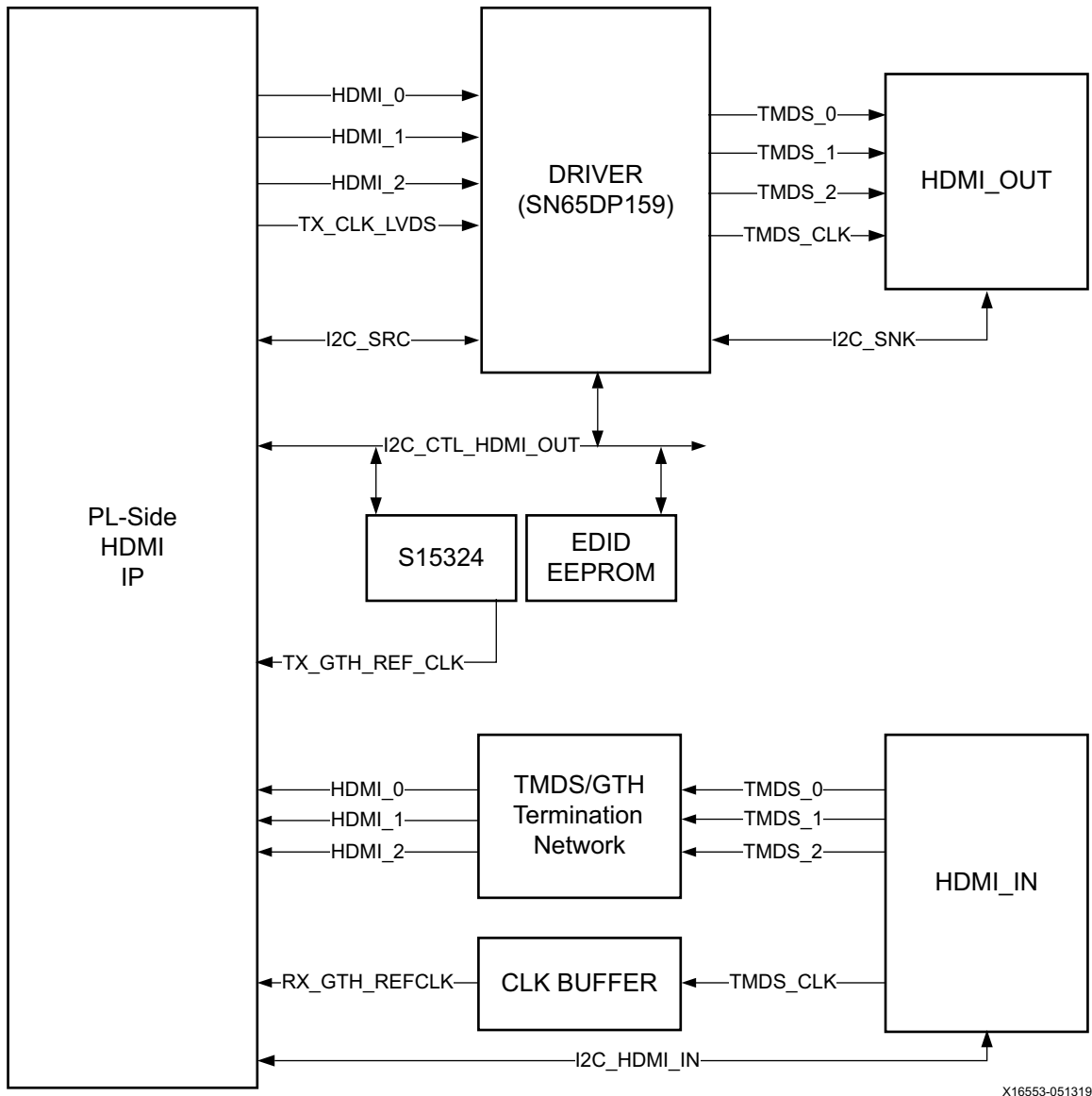

Figure 3-23: HDMI Interface Block Diagram

HDMI Video Input

[Figure 2-1, callout 14]

The ZCU102 board accepts HDMI video input on the TE Connectivity 1888811-1 right-angle dual-stacked HDMI type-A receptacle P7 (lower port). The series capacitor-connected HDMI RX signals are connected to U1 XCZU9F MGTH bank 128.

The ZCU102 HDMI RX interface supports up to 4K 60-Hz resolutions. See the Xilinx HDMI IP documentation for more details about resolutions, color spaces, and optional HDCP features supported by the Zynq® UltraScale+™ device [Ref 4].

Table 3-29: HDMI Retimer U94 Connections to FPGA U1

XCZU9EG (U1) Pin	Schematic Net Name	I/O Standard	Connected Component		
			Pin No.	Pin Name	Device
T29	HDMI_TX0_P	(1)	8	IN_D0P	SN65DP159 (U94)
T30	HDMI_TX0_N	(1)	9	IN_D0N	
R31	HDMI_TX1_P	(1)	5	IN_D1P	
R32	HDMI_TX1_N	(1)	6	IN_D1N	
P29	HDMI_TX2_P	(1)	2	IN_D2P	
P30	HDMI_TX2_N	(1)	3	IN_D2N	
AF6	HDMI_TX_LVDS_OUT_P	LVDS	11	IN_CLKP	
AG6	HDMI_TX_LVDS_OUT_N	LVDS	12	IN_CLKN	
C16	HDMI_TX_SRC_SCL	LVC MOS33	46	SCL_SRC	
D16	HDMI_TX_SRC_SDA	LVC MOS33	47	SDA_SRC	
B15	HDMI_TX_EN	LVC MOS33	42	OE	
F15	HDMI_CTL_SCL	LVC MOS33	15	SCL_CTL	(2)
F16	HDMI_CTL_SDA	LVC MOS33	16	SDA_CTL	
D15	HDMI_RX_CEC_SINK	LVC MOS33	24	CEC_A	TPD12S016RK (U110)
E15	HDMI_RX_SNK_SCL	LVC MOS33	1	SCL_A	
A15	HDMI_RX_SNK_SDA	LVC MOS33	1	SDA_A	
A16	HDMI_TX_CEC	LVC MOS33	24	CEC_A	TPD12S016RK (U70)
B16	HDMI_TX_HPD	LVC MOS33	3	HPD_A	
H12	HDMI_SI5324_LOL	LVC MOS33	18	LOL	SI5324C (U108)
J12	HDMI_SI5324_RST	LVC MOS33	1	RST_B	
F11	HDMI_SI5324_INT_ALM	LVC MOS33	3	INT_C1B	
AG5	HDMI_REC_CLOCK_C_P	LVDS	16	CKIN1_P	
AG4	HDMI_REC_CLOCK_C_N	LVDS	17	CKIN1_N	
R27	HDMI_SI5324_OUT_C_P	(1)	28	CKOUT1_P	
R28	HDMI_SI5324_OUT_C_N	(1)	29	CKOUT1_N	
T33	HDMI_RX0_C_P	(1)	B7	TMDS_DATA0_P	HDMI BOTTOM PORT(P7)
T34	HDMI_RX0_C_N	(1)	B9	TMDS_DATA0_N	
P33	HDMI_RX1_C_P	(1)	B4	TMDS_DATA1_P	
P34	HDMI_RX1_C_N	(1)	B6	TMDS_DATA1_N	
N31	HDMI_RX2_C_P	(1)	B1	TMDS_DATA2_P	
N32	HDMI_RX2_C_N	(1)	B3	TMDS_DATA2_N	
N27	HDMI_RX_CLK_C_P	(1)	B10	TMDS_CLK_P	
N28	HDMI_RX_CLK_C_N	(1)	B12	TMDS_CLK_N	

Table 3-29: HDMI Retimer U94 Connections to FPGA U1 (Cont'd)

XCZU9EG (U1) Pin	Schematic Net Name	I/O Standard	Connected Component		
			Pin No.	Pin Name	Device
D14	HDMI_RX_PWR_DET	LVC MOS33	3	D	Q46
E14	HDMI_RX_HPD	LVC MOS33	1	G	Q41

Notes:

1. U1 MGT (I/O standards do not apply).
2. SN65DP159 (U94), M24C64-W (U109), SI5324C (U108).

HDMI Clock Recovery

[Figure 2-1, callout 40]

The ZCU102 board includes a Silicon Labs Si5324C jitter attenuator U70 (2 kHz - 945 MHz). The FPGA can output the RX recovered clock to a differential I/O pair on I/O bank 66 (HDMI_REC_CLOCK_C_P, pin Y8 and HDMI_REC_CLOCK_C_N, pin Y7) for jitter attenuation.

The jitter attenuated clock (HDMI_SI5324_OUT_C_P (U108 pin 28), HDMI_SI5324_OUT_C_N (U108 pin 29) is then routed as a reference clock to GTH Quad 128 inputs MGTREFCLK0P (U1 pin R27) and MGTREFCLK0N (U1 pin R28).

The Si5324 jitter attenuator is used to generate the reference clock for the HDMI Transmitter Subsystem. When the HDMI transmitter is used standalone, the Si5324 operates in free running mode and uses an external oscillator as the reference. When the HDMI is in pass-through mode, the Si5324 generates a jitter-attenuated reference clock to drive the HDMI Transmitter Subsystem with a phase-aligned version of the HDMI RX Subsystem HDMI RX TMDS clock, so that they are phase aligned. SI5324 clock and jitter enable functions are controlled by HDMI IP. Communication with the SI5324 is available over the HDMI_CTL_SDA/SCL bus connected to the XCZU9 MPSoC U1 PL bank 49. The jitter attenuated clock circuit is shown in [Figure 3-26](#).



IMPORTANT: *The Silicon Labs Si5324C U108 pin 1 reset net HDMI_SI5324_RST must be driven High to enable the device. U108 pin 1 net HDMI_SI5324_RST is connected to FPGA U1 bank 50 pin J12.*

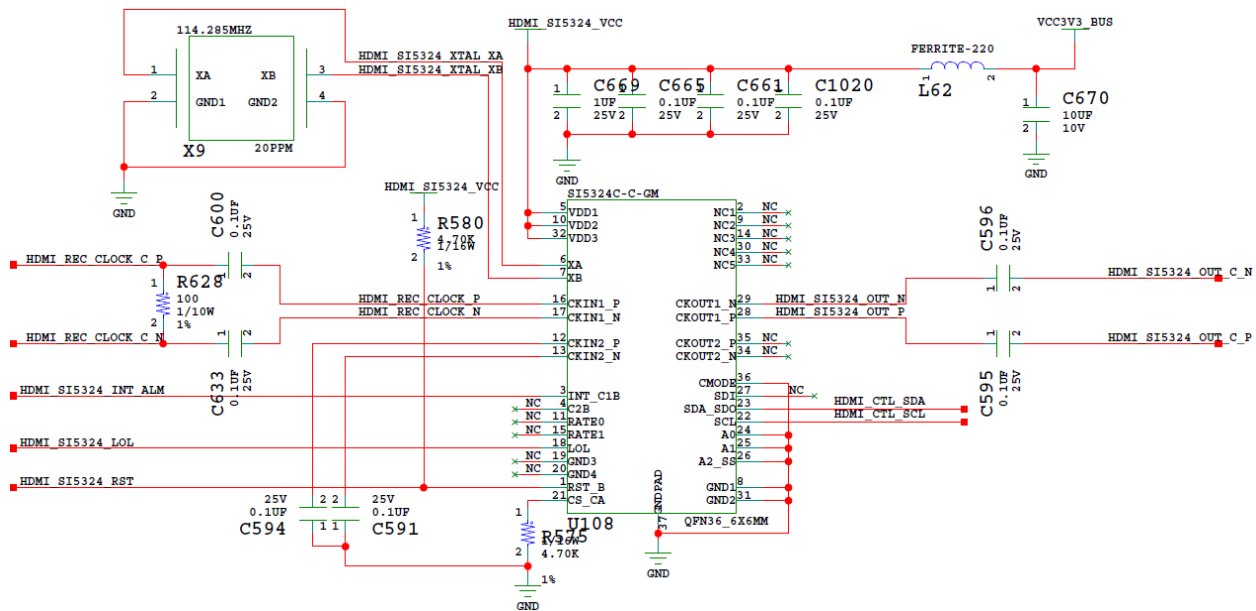

Figure 3-26: HDMI Interface Clock Recovery

For Xilinx HDMI IP details, see the *HDMI 1.4/2.0 Transmitter Subsystem LogiCORE IP Product Guide* (PG235) [Ref 13] and the *HDMI Transmitter and Receiver Subsystem Answer Record 70514* [Ref 14].

See the *HDMI Transmitter and Receiver Subsystem Answer Record 70514* [Ref 14] regarding HDMI-compliant references.

SFP/SFP+ Connector

[Figure 2-1, callout 17]

The ZCU102 board contains a small form-factor pluggable (SFP+) 2x2 quad-connector and cage assembly that accepts SFP or SFP+ modules. Figure 3-27 shows a typical SFP+ module connector circuitry implementation. Table 3-30 lists the connections between the connectors and the XCZU9EG MPSoC.

Note: The SFP module RT_TX_DISABLE pin 3:

- RT_TX_DISABLE module pin 3 SFP Enable 2-pin jumper OFF = logic High = SFP TX disabled, allows FPGA control.
- RT_TX_DISABLE module pin 3 SFP Enable 2-pin jumper ON = logic Low = SFP TX enabled, overrides FPGA control.

- Also, note that the SFPx_TX_DISABLE_TRANS default 2-pin jumper strapping is Open which means the SFPx_TX_DISABLE_TRANS net/SFP module pin 3 is pulled High. Hence, disabling the TX output of SFP module by default.
- The default open TX Enable jumpers allow user-FPGA IP to control activation of each modules' SFPx_TX_DISABLE_TRANS pin independently.
- User-FPGA logic can drive the TX control transistor base (net SFPx_TX_DISABLE) logic Low to disable the SFP module TX, or drive it High to enable the SFP module TX (because the TX control transistor is an inverter).

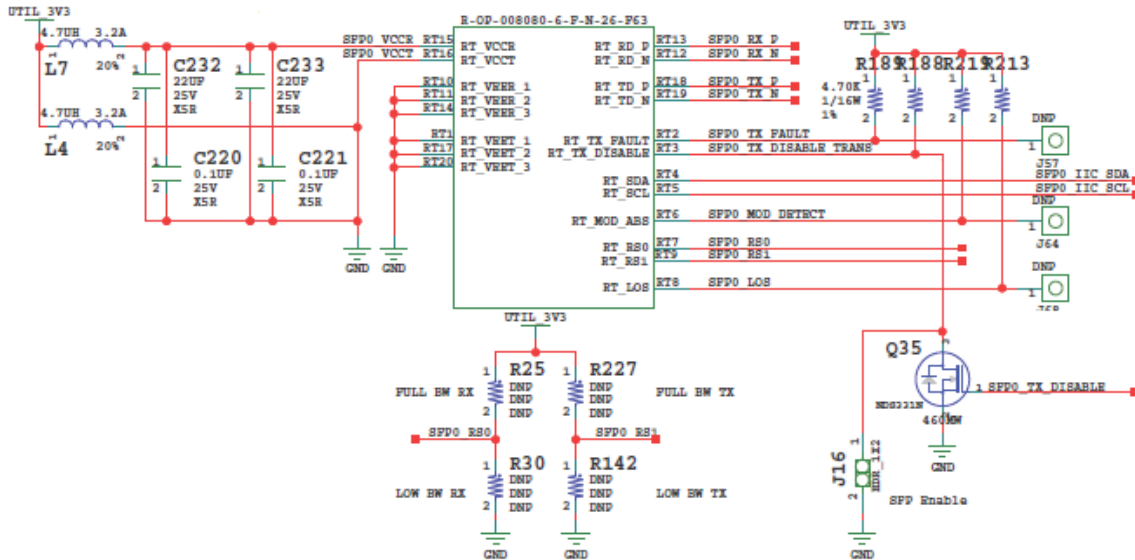

X16536-071817

Figure 3-27: Quad-SFP Interface

Table 3-30: XCZU9EG U1 to P2 SFP+ Module Quad-Connector

XCZU9EG (U1) Pin	Schematic Net Name	SFP+ Pin	SFP+ Pin Name
Location Right Top SFP0			
E4	SFP0_TX_P	RT18	RT_TD_P
E3	SFP0_TX_N	RT19	RT_TD_N
D2	SFP0_RX_P	RT13	RT_RD_P
D1	SFP0_RX_N	RT12	RT_RD_N
A12	SFP0_TX_DISABLE ⁽¹⁾	RT3	RT_TX_DISABLE
Location Right Lower SFP1			
D6	SFP1_TX_P	RL18	RL_TD_P
D5	SFP1_TX_N	RL19	RL_TD_N
C4	SFP1_RX_P	RL13	RL_RD_P
C3	SFP1_RX_N	RL12	RL_RD_N
A13	SFP1_TX_DISABLE ⁽¹⁾	RL3	RL_TX_DISABLE

Table 3-30: XCZU9EG U1 to P2 SFP+ Module Quad-Connector (Cont'd)

XCZU9EG (U1) Pin	Schematic Net Name	SFP+ Pin	SFP+ Pin Name
Location Left Top SFP2			
B6	SFP2_TX_P	LT18	LT_TD_P
B5	SFP2_TX_N	LT19	LT_TD_N
B2	SFP2_RX_P	LT13	LT_RD_P
B1	SFP2_RX_N	LT12	LT_RD_N
B13	SFP2_TX_DISABLE ⁽¹⁾	LT3	LT_TX_DISABLE
Location Left Lower SFP3			
A8	SFP3_TX_P	LL18	LL_TD_P
A7	SFP3_TX_N	LL19	LL_TD_N
A4	SFP3_RX_P	LL13	LL_RD_P
A3	SFP3_RX_N	LL12	LL_RD_N
C13	SFP3_TX_DISABLE ⁽¹⁾	LL3	LL_TX_DISABLE

Notes:

1. SFPx_TX_DISABLE pins should implement the LVCMOS33 I/O standard.

SFP/SFP+ Clock Recovery

[Figure 2-1, callout 11]

The ZCU102 board includes a Silicon Labs Si5328B jitter attenuator U20 (8 kHz - 808 MHz). The FPGA can output the RX recovered clock to a differential I/O pair on I/O bank 67 (SFP_REC_CLOCK_C_P, pin R10 and SFP_REC_CLOCK_C_N, pin R9) for jitter attenuation.

The jitter attenuated clock (SFP_SI5328_OUT_C_P (U20 pin 28), SFP_SI5328_OUT_C_N (U20 pin 29)) is then routed as a reference clock to GTH Quad 230 inputs MGTREFCLK1P (U1 pin B10) and MGTREFCLK1N (U1 pin B9).

The primary purpose of this clock is to support synchronous protocols such as CPRI or OBSAI to perform clock recovery from a user-supplied SFP/SFP+ module and use the jitter attenuated recovered clock to drive the reference clock inputs of a GTH transceiver. The system controller configures the SI5328B in free-run mode (see [TI MSP430 System Controller](#)). Enabling the jitter attenuation feature requires additional user programming

from the FPGA through the I2C bus. The jitter attenuated clock circuit is shown in Figure 3-29.

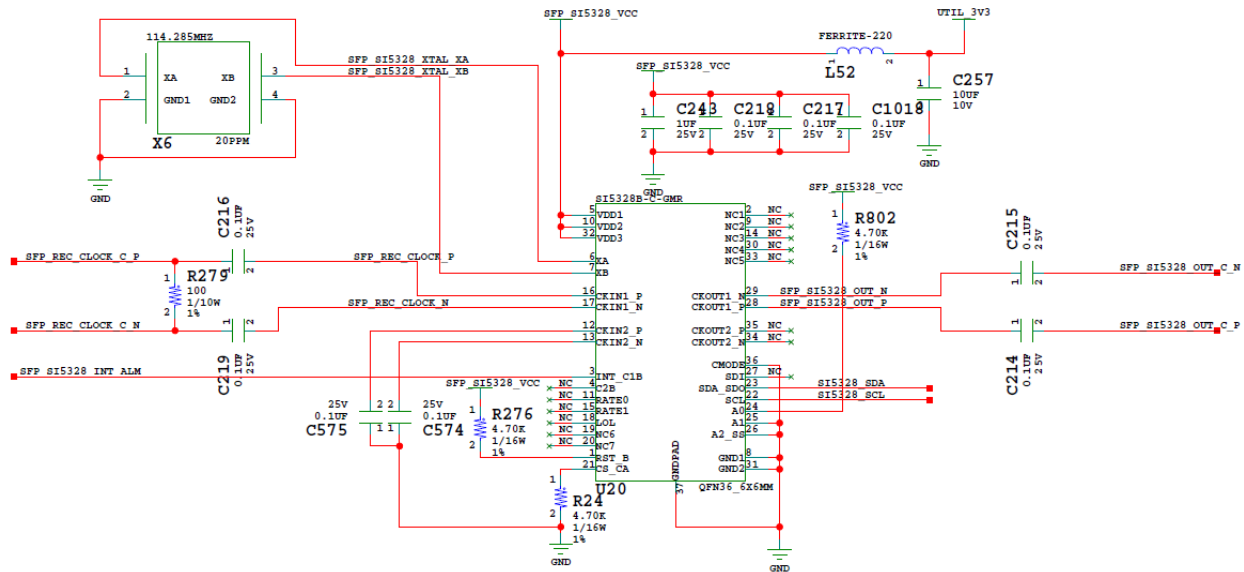
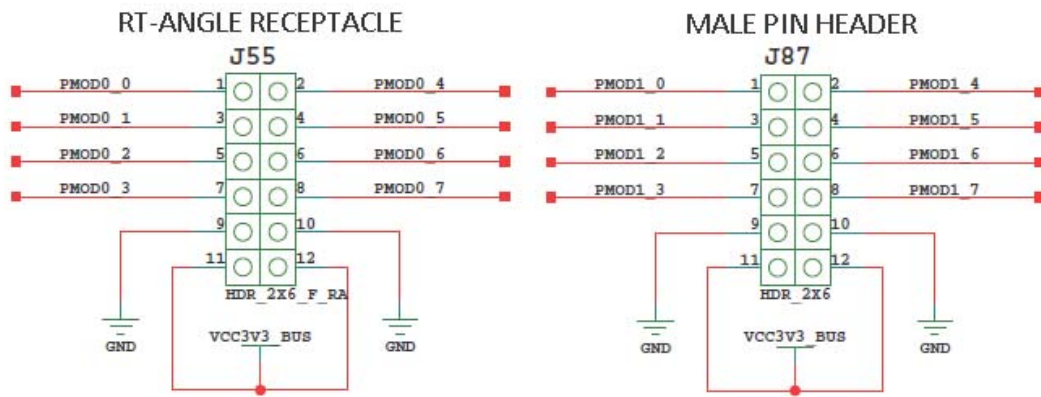

Figure 3-28: SFP/SFP+ Clock Recovery

User PMOD GPIO Headers

[Figure 2-1, callout 19]

The ZCU102 evaluation board supports two PMOD GPIO headers J55 (right-angle female) and J87 (vertical male). The PMOD nets are wired to the XCZU9EG device U1 bank 47. Figure 3-29 shows the GPIO PMOD headers J55 and J87. Table 3-31 lists the connections between the XCZU9EG MPSoC and the PMOD connectors.



X16537-071817

Figure 3-29: PMOD Connectors

Table 3-31: XCZU9EG U1 to PMOD Connections

XCZU9EG (U1) Pin	Schematic Net Name	I/O Standard	PMOD Pin
A20	PMOD0_0	LVC MOS33	J55.1
B20	PMOD0_1	LVC MOS33	J55.3
A22	PMOD0_2	LVC MOS33	J55.5
A21	PMOD0_3	LVC MOS33	J55.7
B21	PMOD0_4	LVC MOS33	J55.2
C21	PMOD0_5	LVC MOS33	J55.4
C22	PMOD0_6	LVC MOS33	J55.6
D21	PMOD0_7	LVC MOS33	J55.8
D20	PMOD1_0	LVC MOS33	J87.1
E20	PMOD1_1	LVC MOS33	J87.3
D22	PMOD1_2	LVC MOS33	J87.5
E22	PMOD1_3	LVC MOS33	J87.7
F20	PMOD1_4	LVC MOS33	J87.2
G20	PMOD1_5	LVC MOS33	J87.4
J20	PMOD1_6	LVC MOS33	J87.6
J19	PMOD1_7	LVC MOS33	J77.8

For more information about PMOD connector compatible PMOD modules, see [\[Ref 30\]](#).

Prototype Header

[Figure 2-1, callout 41]

The ZCU102 evaluation board provides a 2x12 male header prototype header J3 which makes ten Bank 50 GPIO connections available. Figure 3-30 shows connector J3 with its MPSoC (U1) Bank 50 connections.

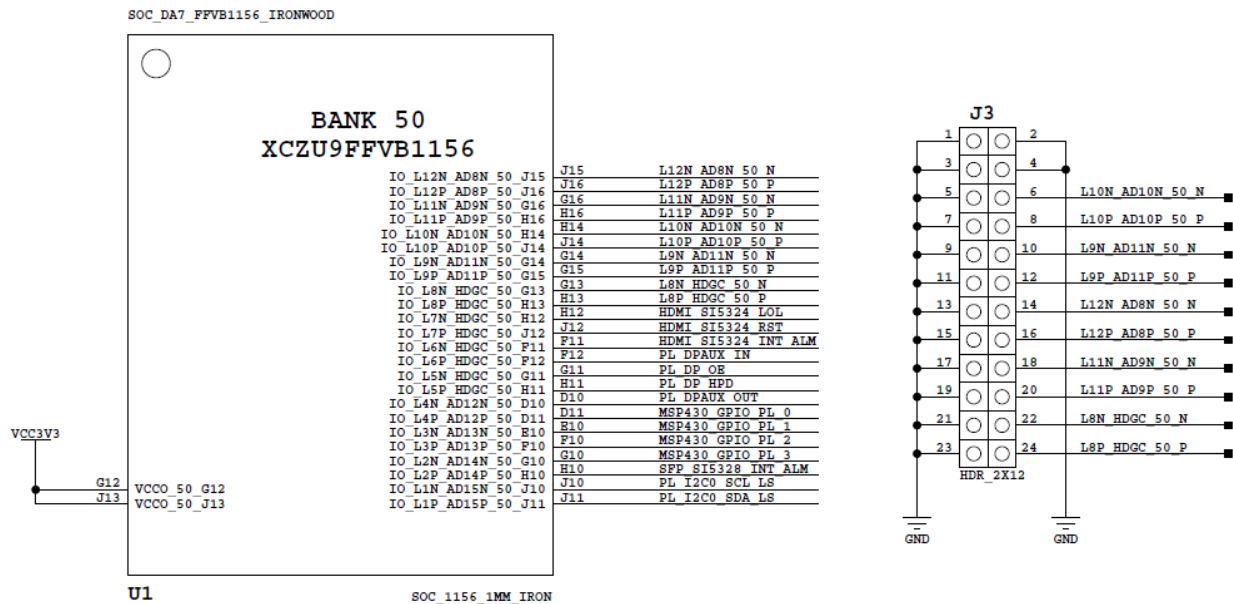

Figure 3-30: Prototype Header J3

The J3 connector to MPSoC connections are listed in Table 3-32.

Table 3-32: Prototype Header J3 Connections to the XCZU9EG MPSoC

XCZU9EG (U1) Pin	Schematic Net Name	I/O Standard	Prototype Header J3 Pin
J15	L12N_AD8N_50_N	LVC MOS33	14
J16	L12P_AD8P_50_P	LVC MOS33	16
G16	L11N_AD9N_50_N	LVC MOS33	18
H16	L11P_AD9P_50_P	LVC MOS33	20
H14	L10N_AD10N_50_N	LVC MOS33	6
J14	L10P_AD10P_50_P	LVC MOS33	8
G14	L9N_AD11N_50_N	LVC MOS33	10
G15	L9P_AD11P_50_P	LVC MOS33	12
G13	L8N_HDGC_50_P	LVC MOS33	22
H13	L8P_HDGC_50_N	LVC MOS33	24

User I2C0 Receptacle

[Figure 2-1, callout 20]

The ZCU102 evaluation board supports a PMOD 2X6 receptacle (right-angle female) J160. Figure 3-31 shows the I2C0 PMOD receptacle J160. The I2C0 nets are a branch of the I2C0 main bus (see Figure 3-17 and I2C0 (MIO 14-15) for more details).

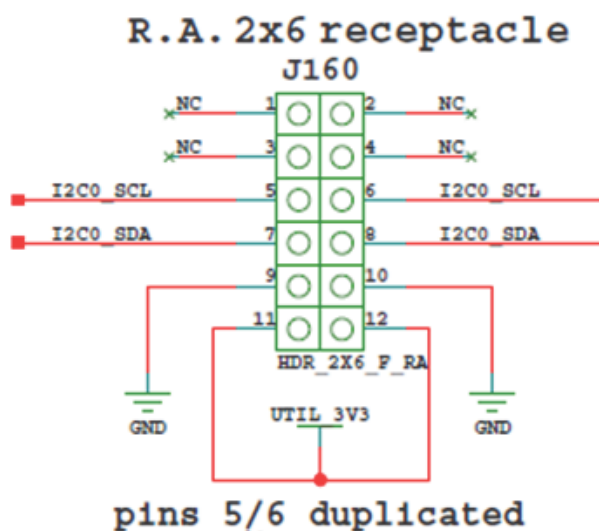

X16538-122118

Figure 3-31: J160 PMOD I2C0 R.A. Receptacle

User I/O

[Figure 2-1, callouts 21-23]

The ZCU102 board provides these user and general purpose I/O capabilities:

- Eight user LEDs (callout 21)
 - GPIO_LED[7:0]: DS38, DS37, DS39, DS40, DS41, DS42, DS43, DS44
- 8-position user DIP Switch (callout 22)
 - GPIO_DIP_SW[7:0]: SW13
- Five user pushbuttons and CPU reset switch (callout 23)
 - GPIO_SW_[NESWC]: SW18, SW17, SW16, SW14, SW15
 - CPU_RESET: SW20

Figures Figure 3-32 through Figure 3-34 show the GPIO circuits, and Table 3-33 lists the GPIO to XCZU9EG U1 connections.

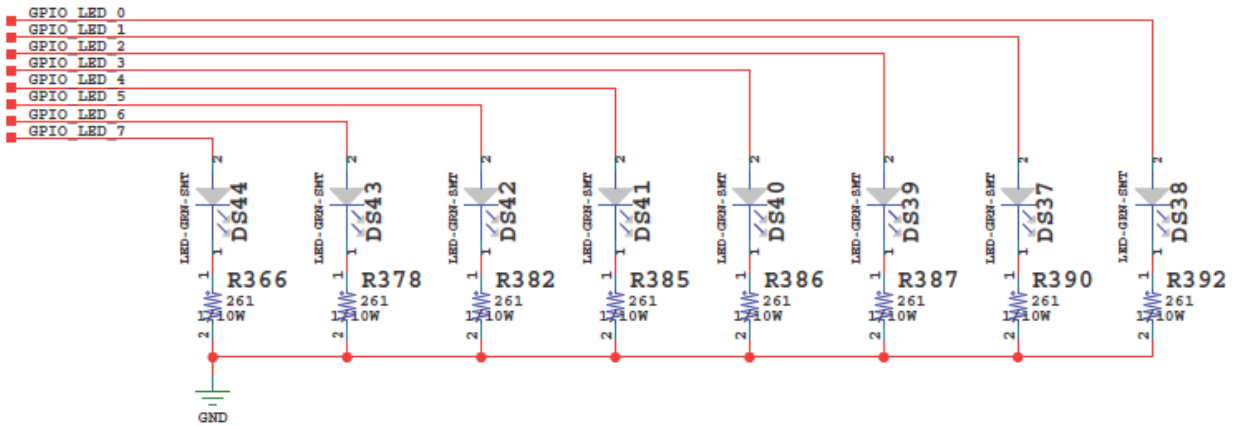

X16539-122118

Figure 3-32: GPIO LEDs

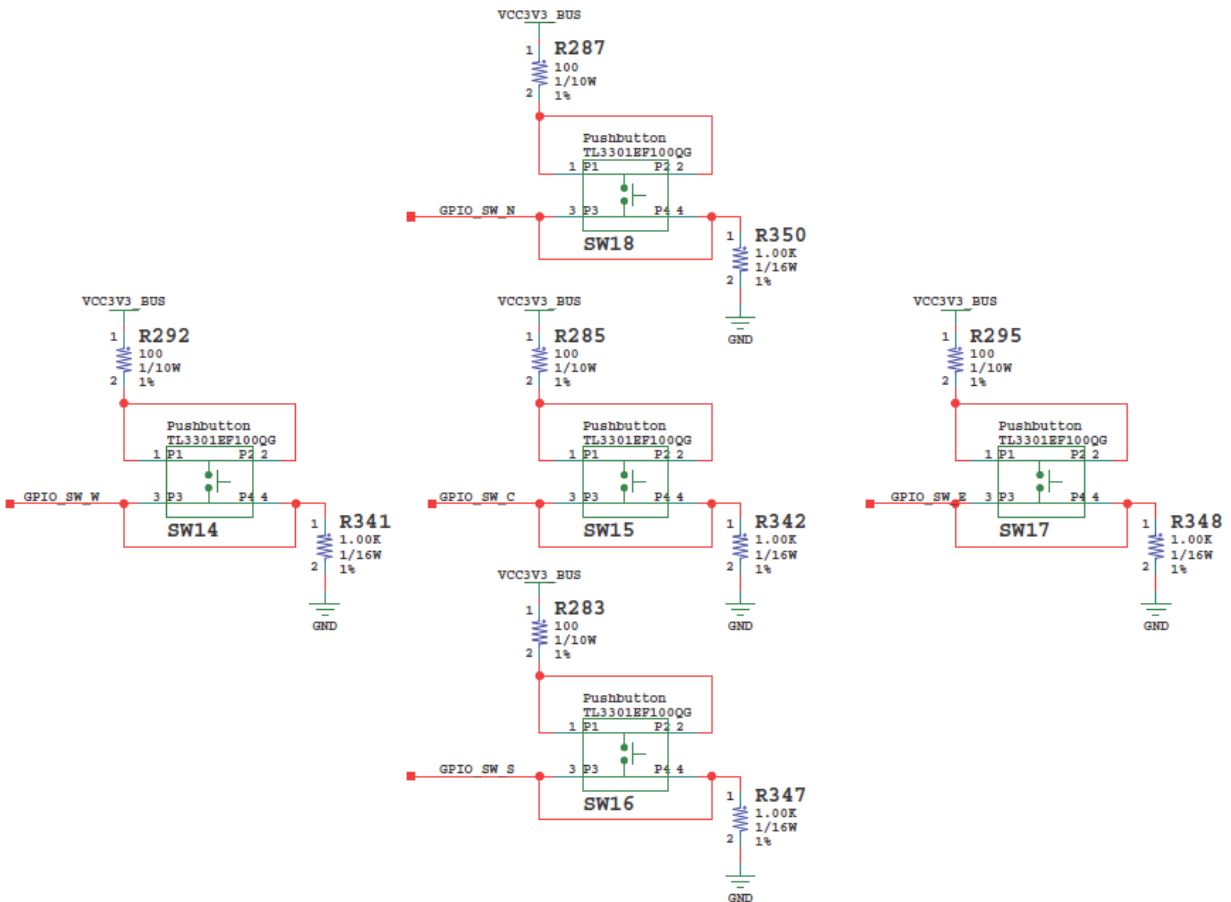

X16541-122118

Figure 3-33: GPIO Pushbutton Switches

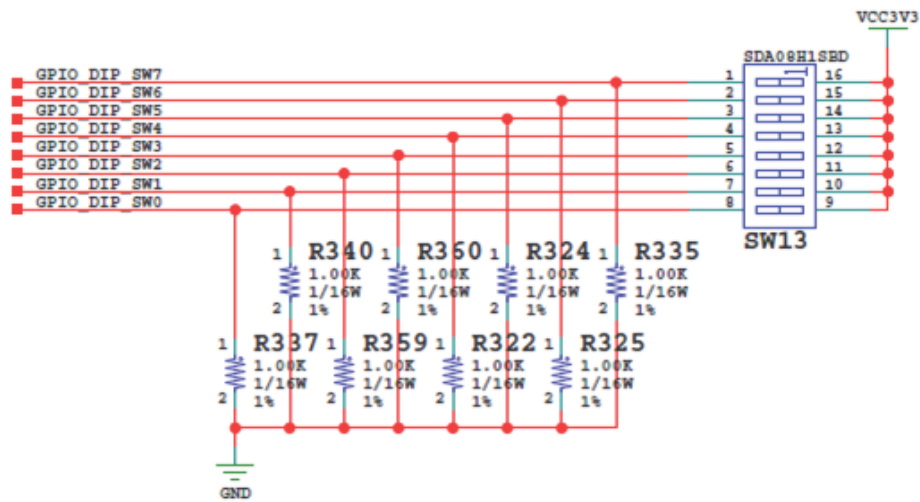

X16542-071817

Figure 3-34: GPIO 8-Pole DIP Switch

Table 3-33: XCZU9EG U1 to GPIO Connections

XCZU9EG (U1) Pin	Schematic Net Name	I/O Standard	Device
GPIO LEDs (Active-High)			
AG14	GPIO_LED_0	LVC MOS33	DS38.2
AF13	GPIO_LED_1	LVC MOS33	DS37.2
AE13	GPIO_LED_2	LVC MOS33	DS39.2
AJ14	GPIO_LED_3	LVC MOS33	DS40.2
AJ15	GPIO_LED_4	LVC MOS33	DS41.2
AH13	GPIO_LED_5	LVC MOS33	DS42.2
AH14	GPIO_LED_6	LVC MOS33	DS43.2
AL12	GPIO_LED_7	LVC MOS33	DS44.2
Directional Pushbuttons (Active-High)			
AG15	GPIO_SW_N	LVC MOS33	SW18.3
AE14	GPIO_SW_E	LVC MOS33	SW17.3
AF15	GPIO_SW_W	LVC MOS33	SW14.3
AE15	GPIO_SW_S	LVC MOS33	SW16.3
AG13	GPIO_SW_C	LVC MOS33	SW15.3
CPU Reset Pushbutton (Active-High)			
AM13	CPU_RESET	LVC MOS33	SW20.3
GPIO DIP SW (Active-High)			
AN14	GPIO_DIP_SW0	LVC MOS33	SW13.8

Table 3-33: XCZU9EG U1 to GPIO Connections (Cont'd)

XCZU9EG (U1) Pin	Schematic Net Name	I/O Standard	Device
AP14	GPIO_DIP_SW1	LVC MOS33	SW13.7
AM14	GPIO_DIP_SW2	LVC MOS33	SW13.6
AN13	GPIO_DIP_SW3	LVC MOS33	SW13.5
AN12	GPIO_DIP_SW4	LVC MOS33	SW13.4
AP12	GPIO_DIP_SW5	LVC MOS33	SW13.3
AL13	GPIO_DIP_SW6	LVC MOS33	SW13.2
AK13	GPIO_DIP_SW7	LVC MOS33	SW13.1

Power and Status LEDs

[Figure 2-1, callout 21]

Table 3-34 defines the power and status LEDs. For user-controlled LEDs see [User I/O](#).

Table 3-34: Power and Status LEDs

Reference Designator	Schematic Net Name	LED Color	Description
DS1	FPGA_INIT_B	Green/Red	Green: FPGA initialization was successful Red: FPGA initialization is in progress
DS2	VCC12_SW	Green	12VDC Power ON
DS3	VCCAUX_PGOOD	Green	VCCAUX 1.8VDC Power ON
DS4	VCC3V3_PGOOD	Green	VCC3V3 3.3VDC Power ON
DS5	VCCINT_PGOOD	Green	VCCINT 0.85VDC Power ON
DS6	VADJ_FMC_PGOOD	Green	VADJ_FMC 1.8VDC (Nom.) Power ON
DS7	VCC1V2_PGOOD	Green	VCC1V2 1.2VDC Power ON
DS8	VCCBRAM_PGOOD	Green	VCCBRAM 0.85VDC Power ON
DS9	MGTAVTT_PGOOD	Green	MGTAVTT 1.2VDC Power ON
DS10	MGTAVCC_PGOOD	Green	MGTAVCC 0.9VDC Power ON
DS11	VCCPSINTFP_PGOOD	Green	VCCPSINTFP 0.85VDC Power ON
DS12	MGTRAVCC_PGOOD	Green	MGTRAVCC 0.85VDC Power ON
DS13	MGTVCCAUX_PGOOD	Green	MGTVCCAUX 1.81VDC Power ON
DS14	VCCPSAUX_PGOOD	Green	VCCPSAUX 1.81VDC Power ON
DS15	VCCPSPLL_PGOOD	Green	VCCPSPLL 1.2VDC Power ON
DS16	VCCPSINTLP_PGOOD	Green	VCCPSINTLP 0.85VDC Power ON
DS17	DDR4_DIMM_VDDQ_PGOOD	Green	DDR4_DIMM_VDDQ 1.2VDC Power ON
DS18	MGTRAVTT_PGOOD	Green	MGTRAVTT 1.81VDC Power ON

Table 3-34: Power and Status LEDs (Cont'd)

Reference Designator	Schematic Net Name	LED Color	Description
DS19	PS_DDR4_VPP_2V5	Green	PS_DDR4_VPP_2V5 2.5VDC Power ON
DS20	PL_DDR4_VPP_2V6	Green	PL_DDR4_VPP_2V5 2.5VDC Power ON
DS21	VCCOPS_PGOOD	Green	VCCOPS 1.80VDC Power ON
DS22	UTIL_5V0_PGOOD	Green	UTIL_5V0 5VDC Power ON
DS24	VCCPSDDRPLL_PGOOD	Green	VCCPSDDRPLL 1.81VDC Power ON
DS25	UTIL_3V3_PGOOD	Green	UTIL_3V3 3.3VDC Power ON
DS26	VCCOPS3_PGOOD	Green	VCCOPS3 1.81VDC Power ON
DS27	ENET_LED_1	Green	EHPY U98 1000BASE-T link is established
DS29	UTIL_1V8	Green	UTIL_1V8 1.8VDC Power ON
DS30	PL_DDR4_VTERM_0V60_PGOOD	Green	PL_DDR4_VTERM 0.6VDC Power ON
DS31	PS_DDR4_VTERM_0V60_PGOOD	Green	PS_DDR4_VTERM 0.6VDC Power ON
DS32	DONE	Green	MPSoC U1 bit file download is complete
DS33	PS_ERR_STATUS ⁽¹⁾	Green	PS error status indicates a secure lockdown state. Alternatively, it can be used by the PMU firmware to indicate system status.
DS34	DP_VCC3V3	Green	Display Port 3.3VDC Power ON
DS35	PS_ERR_OUT ⁽¹⁾	Red	PS error out is asserted for accidental loss of power, an error in the PMU that holds the CSU in reset, or an exception in the PMU.
DS36	POR_RST_B	Red	POR U22 asserts RST_B low when any of the monitored voltages (IN_) falls below its respective threshold, any EN_ goes low, or MR is asserted.
DS37-DS44	GPIO_LED_1, GPIO_LED_[0,2:7]	Green	USER GPIO LEDs
DS46	MSP430_LED1	Green	MSP430 U41 GPIO LED
DS47	MSP430_LED0	Green	MSP430 U41 GPIO LED
DS49	UTIL_1V13_PG	Green	UTIL_1V13 1.13VDC Power ON
DS50	MIO23_LED	Green	MPSoC U1 Bank 500 GPIO LED
DS51	MIC2544 U121 FLG	Green	PS USB 3.0 ULPI VBUS Power Error

Notes:

1. See the *Zynq UltraScale+ MPSoC Technical Reference Manual (UG1085)* [Ref 3] for more information about Zynq UltraScale+ MPSoC configuration pins.

Figure 3-35 shows the power and status LEDs.

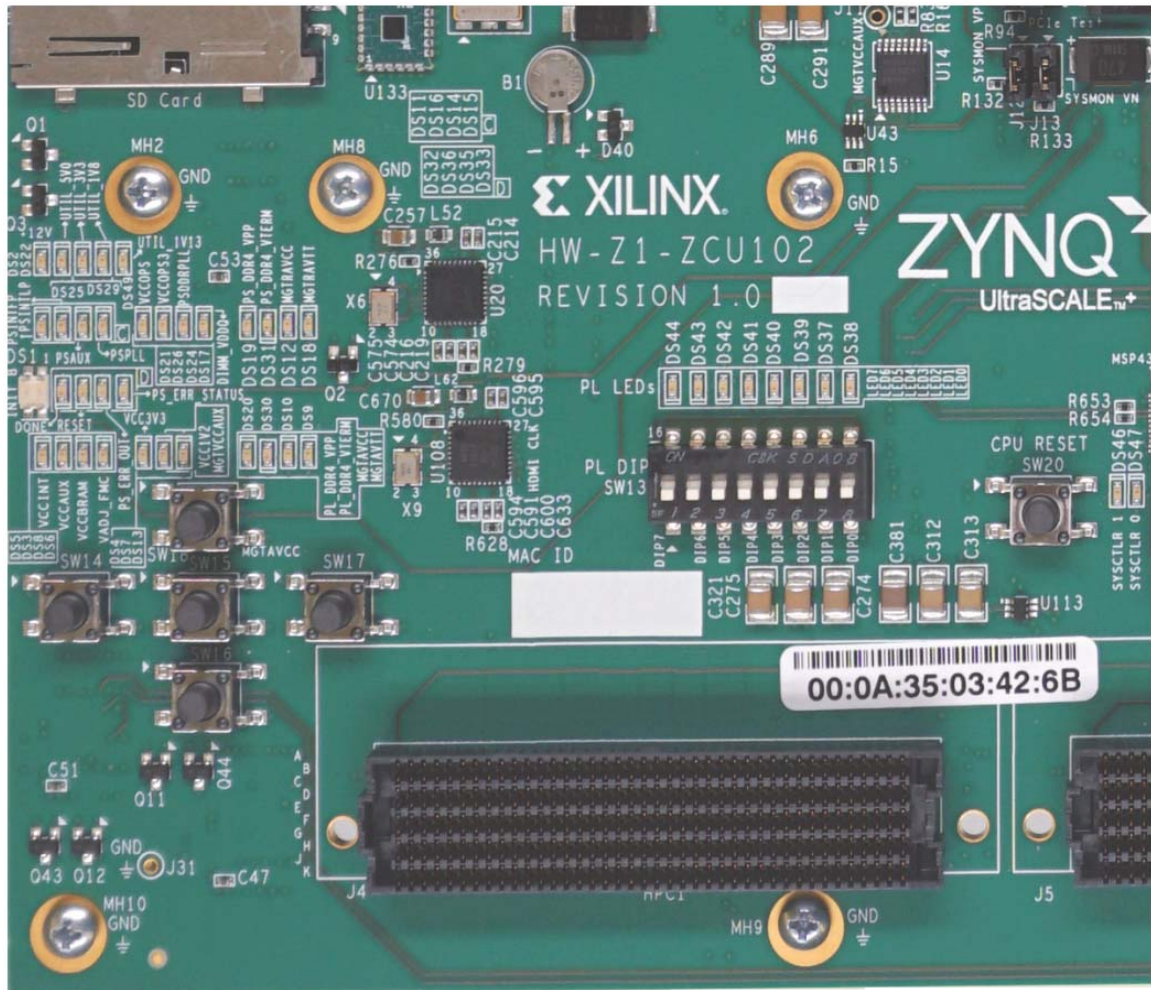

X18039-071817

Figure 3-35: Power and Status LEDs

GTH Transceivers

[Figure 2-1, callout 1]

The Zynq UltraScale+ MPSoC has 24 GTH gigabit transceivers (16.3 Gb/s capable) on the PL-side.

The GTH transceivers in the XCZU9EG device are grouped into four channels referred to as Quads. The reference clock for a Quad can be sourced from the Quad above or Quad below the GTH Quad of interest. There are six GTH Quads on the ZCU102 board with connectivity as shown here:

- Two of the GTH transceivers are wired to the FMC0 HPC connector (J5)
- Two of the GTH transceivers are wired to the FMC1 HPC connector (J4)

- One of the GTH transceivers is wired to SFP/SFP+ Quad-Module connector (P2)
- One GTH transceiver is wired to the HDMI retimer U94 and a set of GTH SMAs

Quad 128:

- MGTREFCLK0 - HDMI_SI5324_OUT_C_P/N
- MGTREFCLK1 - HDMI_RX_CLK_C_P/N
- Contains 3 GTH transceivers allocated to HDMI_TX/RX[0:2]_P/N
- Contains 1 GTH transceiver allocated to a set of SMA connectors (SMA_MGT_TX and RX P/N)

Quad 129:

- MGTREFCLK0 - USER_MGT_SI570_CLOCK1_C_P/N
- MGTREFCLK1 - USER_SMA_MGT_CLOCK_C_P/N
- Contains 4 GTH transceivers allocated to FMC_HPC1_DP[4:7]_C2M/M2C_P/N

Quad 130:

- MGTREFCLK0 - FMC_HPC1_GBTCLK0_M2C_P/N
- MGTREFCLK1 - FMC_HPC1_GBTCLK1_M2C_P/N
- Contains 4 GTH transceivers allocated to FMC_HPC1_DP[0:3]_C2M/M2C_P/N

Quad 228:

- MGTREFCLK0 - FMC_HPC0_GBTCLK1_M2C_P/N
- MGTREFCLK1 - Not connected
- Contains 4 GTH transceivers allocated to FMC_HPC0_DP[4:7]_C2M/M2C_P/N

Quad 229:

- MGTREFCLK0 - FMC_HPC0_GBTCLK0_M2C_P/N
- MGTREFCLK1 - Not connected
- Contains 4 GTH transceivers allocated to FMC_HPC0_DP[0:3]_C2M/M2C_P/N

Quad 230:

- MGTREFCLK0 - USER_MGT_SI570_CLOCK2_C_P/N
- MGTREFCLK1 - SFP_SI5328_OUT_C_P/N
- Contains 4 GTH transceivers allocated to SFP[0:3]_TX/RX_P/N

GTH usage on the ZCU102 is shown in [Figure 3-36](#).

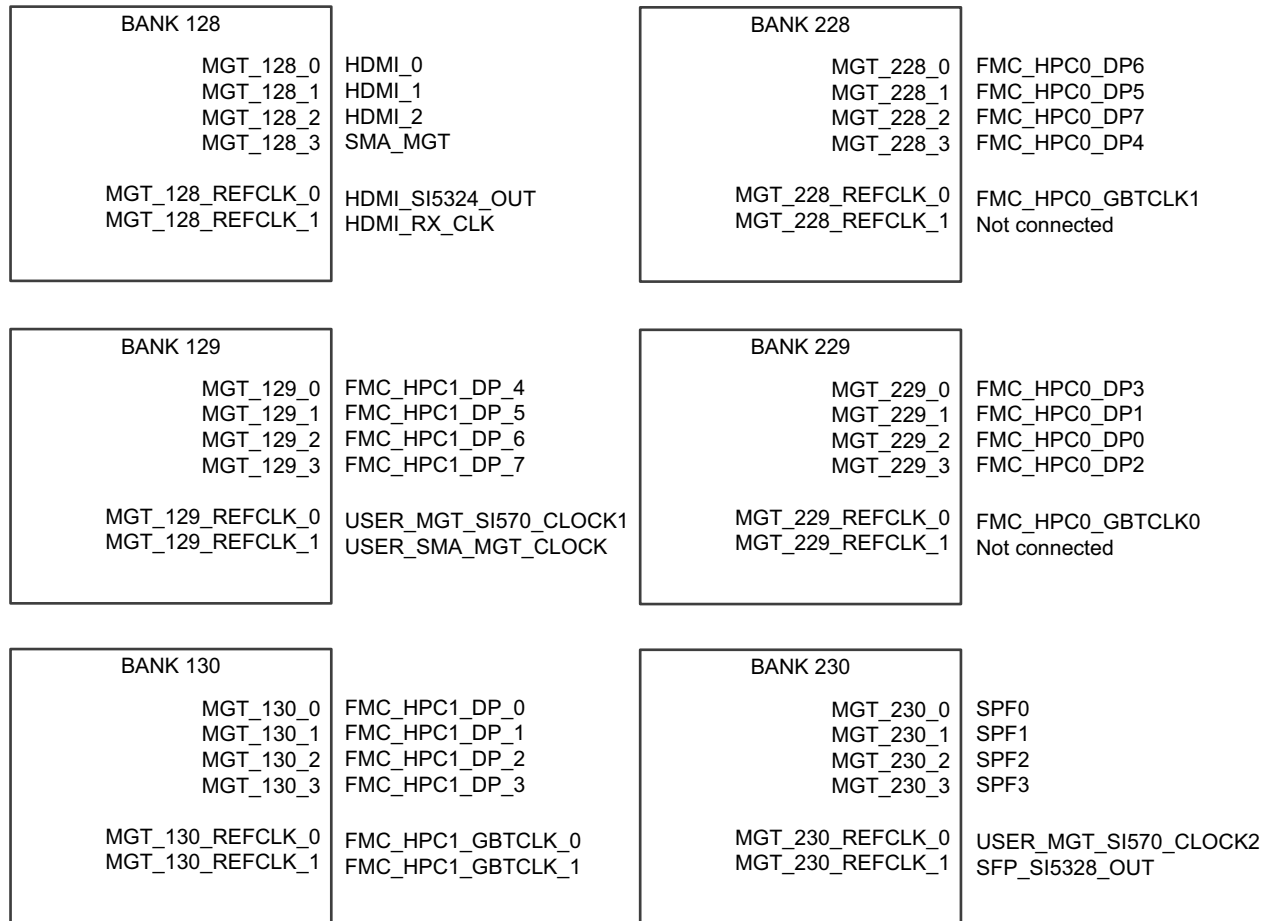

X16543-071917

Figure 3-36: GTH Bank Assignments

FMC HPC_0

Eight (8) MGTs in a common FPGA column are provided by PL-side MGT banks 228 and 229. Available MGT reference clocks include the FMC defined GBT clocks 0 and 1 for HPC_0, a programmable Si570 clock, and a jitter attenuated recovered clock from a Si5328. The MGT reference clocks are located in adjacent MGT banks, 228, 229, and 230.

FMC HPC_1

Eight (8) MGTs in a common FPGA column are provided by PL-side MGT banks 129 and 130. Available MGT reference clocks include the FMC defined GBT clocks 0 and 1 for HPC_1, a programmable Si570 clock, and a user provided SMA clock. The MGT reference clocks are located in adjacent MGT banks, 128, 129, and 130.

SFP+

Four (4) PL-side GTH transceivers in Bank 230 are provided for the quad SFP+ interface. Available GTH reference clocks include a programmable Si570 clock, and a jitter attenuated recovered clock from a Si5328.

SFP+ modules typically provide an I2C based control interface. This I2C interface is accessible for each individual SFP+ module through the I2C multiplexer topology on the ZCU102.

HDMI

Three (3) PL-side GTH transceivers are dedicated for HDMI source and sink. Modes supported are 4K, 2K at 60 f/s and 2160p60. External circuitry for interfacing TMDS signals with the GTH transceivers is required.

SMA

One (1) MGT in Bank 128 is provided on a SMA connector pair. Available MGT clocks include a user provided MGT reference clock on an SMA connector pair, and a programmable Si570 clock. [Table 3-35](#) lists GTH bank 128 connections.

Table 3-35: ZCU102 GTH Bank 128 Interface Connections

XCZU9EG (U1) Pin	XCZU9EG (U1) Pin Name	Schematic Net Name ⁽²⁾	Connected To		
			Pin No.	Pin Name	Device
T29	MGHTXP0_128	HDMI_TX0_P	8	IN_D0P	TI SN65DP159RGZ HDMI RETIMER U94
T30	MGHTXN0_128	HDMI_TX0_N	9	IN_D0N	
R31	MGHTXP1_128	HDMI_TX1_P	5	IN_D1P	
R32	MGHTXN1_128	HDMI_TX1_N	6	IN_D1N	
P29	MGHTXP2_128	HDMI_TX2_P	2	IN_D2P	
P30	MGHTXN2_128	HDMI_TX2_N	3	IN_D2N	
T33	MGTHRX0_128	HDMI_RX0_C_P ⁽¹⁾	B7	TMDS_DATA0_P	MOLEX HDMI BOTTOM PORT P7
T34	MGTHRXN0_128	HDMI_RX0_C_N ⁽¹⁾	B9	TMDS_DATA0_N	
P33	MGTHRX1_128	HDMI_RX1_C_P ⁽¹⁾	B4	TMDS_DATA1_P	
P34	MGTHRXN1_128	HDMI_RX1_C_N ⁽¹⁾	B6	TMDS_DATA1_N	
N31	MGTHRX2_128	HDMI_RX2_C_P ⁽¹⁾	B1	TMDS_DATA2_P	
N32	MGTHRXN2_128	HDMI_RX2_C_N ⁽¹⁾	B3	TMDS_DATA2_N	
N27	MGTREFCLK1P_18	HDMI_RX_CLK_C_P ⁽¹⁾	B10	TMDS_CLK_P	
N28	MGTREFCLK1N_128	HDMI_RX_CLK_C_N ⁽¹⁾	B12	TMDS_CLK_N	
M29	MGHTXP3_128	SMA_MGT_TX_P	1	SIG	SMA J71
M30	MGHTXN3_128	SMA_MGT_TX_N	1	SIG	SMA J72

Table 3-35: ZCU102 GTH Bank 128 Interface Connections (Cont'd)

XCZU9EG (U1) Pin	XCZU9EG (U1) Pin Name	Schematic Net Name ⁽²⁾	Connected To		
			Pin No.	Pin Name	Device
M33	MGTHRXP3_128	SMA_MGT_RX_C_P ⁽¹⁾	1	SIG	SMA J69
M34	MGTHRXN3_128	SMA_MGT_RX_C_N ⁽¹⁾	1	SIG	SMA J70
R27	MGTREFCLK0P_128	HDMI_SI5324_OUT_C_P ⁽¹⁾	28	CKOUT1_P	SI5324C JITTER ATTEN. U108
R28	MGTREFCLK0N_128	HDMI_SI5324_OUT_C_N ⁽¹⁾	29	CKOUT1_N	

Notes:

- Series capacitor coupled.
- MGT connections I/O standard not applicable.

Table 3-36 lists GTH bank 129 connections.

Table 3-36: ZCU102 GTH Bank 129 Interface Connections

XCZU9EG (U1) Pin	XCZU9EG (U1) Pin Name	Schematic Net Name ⁽²⁾	Connected To		
			Pin No.	Pin Name	Device
K29	MGTHTXP0_129	FMC_HPC1_DP4_C2M_P	A34	DP4_C2M_P	FMC HPC1 J4
K30	MGTHTXN0_129	FMC_HPC1_DP4_C2M_N	A35	DP4_C2M_N	
L31	MGTHRXP0_129	FMC_HPC1_DP4_M2C_P	A14	DP4_M2C_P	
L32	MGTHRXN0_129	FMC_HPC1_DP4_M2C_N	A15	DP4_M2C_N	
J31	MGTHTXP1_129	FMC_HPC1_DP5_C2M_P	A38	DP5_C2M_P	
J32	MGTHTXN1_129	FMC_HPC1_DP5_C2M_N	A39	DP5_C2M_N	
K33	MGTHRXP1_129	FMC_HPC1_DP5_M2C_P	A18	DP5_M2C_P	
K34	MGTHRXN1_129	FMC_HPC1_DP5_M2C_N	A19	DP5_M2C_N	
H29	MGTHTXP2_129	FMC_HPC1_DP6_C2M_P	B36	DP6_C2M_P	
H30	MGTHTXN2_129	FMC_HPC1_DP6_C2M_N	B37	DP6_C2M_N	
H33	MGTHRXP2_129	FMC_HPC1_DP6_M2C_P	B16	DP6_M2C_P	
H34	MGTHRXN2_129	FMC_HPC1_DP6_M2C_N	B17	DP6_M2C_N	
G31	MGTHTXP3_129	FMC_HPC1_DP7_C2M_P	B32	DP7_C2M_P	
G32	MGTHTXN3_129	FMC_HPC1_DP7_C2M_N	B33	DP7_C2M_N	
F33	MGTHRXP3_129	FMC_HPC1_DP7_M2C_P	B12	DP7_M2C_P	
F34	MGTHRXN3_129	FMC_HPC1_DP7_M2C_N	B13	DP7_M2C_N	
L27	MGTREFCLK0P_129	USER_MGT_SI570_CLOCK1_C_P ⁽¹⁾	11	Q1_P	SI53340 ⁽³⁾ BUFF. U51
L28	MGTREFCLK0N_129	USER_MGT_SI570_CLOCK1_C_N ⁽¹⁾	12	Q1_N	
J27	MGTREFCLK1P_129	USER_SMA_MGT_CLOCK_C_P ⁽¹⁾	1	SIG	J79

Table 3-36: ZCU102 GTH Bank 129 Interface Connections (Cont'd)

XCZU9EG (U1) Pin	XCZU9EG (U1) Pin Name	Schematic Net Name ⁽²⁾	Connected To		
			Pin No.	Pin Name	Device
J28	MGTREFCLK1N_129	USER_SMA_MGT_CLOCK_C_N ⁽¹⁾	1	SIG	J80

Notes:

1. Series capacitor coupled.
2. MGT connections I/O standard not applicable.
3. U51 buffer driven by SI570 U56 (156.250 MHz default)

Table 3-37 lists GTH bank 130 connections.

Table 3-37: ZCU102 GTH Bank 130 Interface Connections

XCZU9EG (U1) Pin	XCZU9EG (U1) Pin Name	Schematic Net Name ⁽²⁾	Connected To		
			Pin No.	Pin Name	Device
F29	MGTHTXP0_130	FMC_HPC1_DP0_C2M_P	C2	DP0_C2M_P	FMC HPC1 J4
F30	MGTHTXN0_130	FMC_HPC1_DP0_C2M_N	C3	DP0_C2M_N	
E31	MGTHRXP0_130	FMC_HPC1_DP0_M2C_P	C6	DP0_M2C_P	
E32	MGTHRXN0_130	FMC_HPC1_DP0_M2C_N	C7	DP0_M2C_N	
D29	MGTHTXP1_130	FMC_HPC1_DP1_C2M_P	A22	DP1_C2M_P	
D30	MGTHTXN1_130	FMC_HPC1_DP1_C2M_N	A23	DP1_C2M_N	
D33	MGTHRXP1_130	FMC_HPC1_DP1_M2C_P	A2	DP1_M2C_P	
D34	MGTHRXN1_130	FMC_HPC1_DP1_M2C_N	A3	DP1_M2C_N	
B29	MGTHTXP2_130	FMC_HPC1_DP2_C2M_P	A26	DP2_C2M_P	
B30	MGTHTXN2_130	FMC_HPC1_DP2_C2M_N	A27	DP2_C2M_N	
C31	MGTHRXP2_130	FMC_HPC1_DP2_M2C_P	A6	DP2_M2C_P	
C32	MGTHRXN2_130	FMC_HPC1_DP2_M2C_N	A7	DP2_M2C_N	
A31	MGTHTXP3_130	FMC_HPC1_DP3_C2M_P	A30	DP3_C2M_P	
A32	MGTHTXN3_130	FMC_HPC1_DP3_C2M_N	A31	DP3_C2M_N	
B33	MGTHRXP3_130	FMC_HPC1_DP3_M2C_P	A10	DP3_M2C_P	
B34	MGTHRXN3_130	FMC_HPC1_DP3_M2C_N	A11	DP3_M2C_N	
G27	MGTREFCLK0P_130	FMC_HPC1_GBTCLK0_M2C_C_P ⁽¹⁾	D4	GBTCLK0_M2C_P	
G28	MGTREFCLK0N_130	FMC_HPC1_GBTCLK0_M2C_C_N ⁽¹⁾	D5	GBTCLK0_M2C_N	
E27	MGTREFCLK1P_130	FMC_HPC1_GBTCLK1_M2C_C_P ⁽¹⁾	B20	GBTCLK1_M2C_P	
E28	MGTREFCLK1N_130	FMC_HPC1_GBTCLK1_M2C_C_N ⁽¹⁾	B21	GBTCLK1_M2C_N	

Notes:

1. Series capacitor coupled.
2. MGT connections I/O standard not applicable.

Table 3-38 lists GTH bank 228 connections.

Table 3-38: ZCU102 GTH Bank 228 Interface Connections

XCZU9EG (U1) Pin	XCZU9EG (U1) Pin Name	Schematic Net Name ⁽²⁾	Connected To		
			Pin No.	Pin Name	Device
R4	MGTHTXP0_228	FMC_HPC0_DP6_C2M_P	B36	DP6_C2M_P	FMC HPC0 J5
R3	MGTHTXN0_228	FMC_HPC0_DP6_C2M_N	B37	DP6_C2M_N	
T2	MGTHRXP0_228	FMC_HPC0_DP6_M2C_P	B16	DP6_M2C_P	
T1	MGTHRXN0_228	FMC_HPC0_DP6_M2C_N	B17	DP6_M2C_N	
P6	MGTHTXP1_228	FMC_HPC0_DP5_C2M_P	A38	DP5_C2M_P	
P5	MGTHTXN1_228	FMC_HPC0_DP5_C2M_N	A39	DP5_C2M_N	
P2	MGTHRXP1_228	FMC_HPC0_DP5_M2C_P	A18	DP5_M2C_P	
P1	MGTHRXN1_228	FMC_HPC0_DP5_M2C_N	A19	DP5_M2C_N	
N4	MGTHTXP2_228	FMC_HPC0_DP7_C2M_P	B32	DP7_C2M_P	
N3	MGTHTXN2_228	FMC_HPC0_DP7_C2M_N	B33	DP7_C2M_N	
M2	MGTHRXP2_228	FMC_HPC0_DP7_M2C_P	B12	DP7_M2C_P	
M1	MGTHRXN2_228	FMC_HPC0_DP7_M2C_N	B13	DP7_M2C_N	
M6	MGTHTXP3_228	FMC_HPC0_DP4_C2M_P	A34	DP4_C2M_P	
M5	MGTHTXN3_228	FMC_HPC0_DP4_C2M_N	A35	DP4_C2M_N	
L4	MGTHRXP3_228	FMC_HPC0_DP4_M2C_P	A14	DP4_M2C_P	
L3	MGTHRXN3_228	FMC_HPC0_DP4_M2C_N	A15	DP4_M2C_N	
L8	MGTREFCLK0P_228	FMC_HPC0_GBTCLK1_M2C_C_P ⁽¹⁾	B20	GBTCLK1_M2C_P	
L7	MGTREFCLK0N_228	FMC_HPC0_GBTCLK1_M2C_C_N ⁽¹⁾	B21	GBTCLK1_M2C_N	
J8	MGTREFCLK1P_228	NC	NA	NA	N/A
J7	MGTREFCLK1N_228	NC	NA	NA	N/A

Notes:

1. Series capacitor coupled.
2. MGT connections I/O standard not applicable.

Table 3-39 lists GTH bank 229 connections.

Table 3-39: ZCU102 GTH Bank 229 Interface Connections

XCZU9EG (U1) Pin	XCZU9EG (U1) Pin Name	Schematic Net Name ⁽²⁾	Connected To			
			Pin No.	Pin Name	Device	
K6	MGTHTXP0_229	FMC_HPC0_DP3_C2M_P	A30	DP3_C2M_P	FMC HPC0 J5	
K5	MGTHTXN0_229	FMC_HPC0_DP3_C2M_N	A31	DP3_C2M_N		
K2	MGTHRXP0_229	FMC_HPC0_DP3_M2C_P	A10	DP3_M2C_P		
K1	MGTHRXN0_229	FMC_HPC0_DP3_M2C_N	A11	DP3_M2C_N		
H6	MGTHTXP1_229	FMC_HPC0_DP1_C2M_P	A22	DP1_C2M_P		
H5	MGTHTXN1_229	FMC_HPC0_DP1_C2M_N	A23	DP1_C2M_N		
J4	MGTHRXP1_229	FMC_HPC0_DP1_M2C_P	A2	DP1_M2C_P		
J3	MGTHRXN1_229	FMC_HPC0_DP1_M2C_N	A3	DP1_M2C_N		
G4	MGTHTXP2_229	FMC_HPC0_DP0_C2M_P	C2	DP0_C2M_P		
G3	MGTHTXN2_229	FMC_HPC0_DP0_C2M_N	C3	DP0_C2M_N		
H2	MGTHRXP2_229	FMC_HPC0_DP0_M2C_P	C6	DP0_M2C_P		
H1	MGTHRXN2_229	FMC_HPC0_DP0_M2C_N	C7	DP0_M2C_N		
F6	MGTHTXP3_229	FMC_HPC0_DP2_C2M_P	A26	DP2_C2M_P		
F5	MGTHTXN3_229	FMC_HPC0_DP2_C2M_N	A27	DP2_C2M_N		
F2	MGTHRXP3_229	FMC_HPC0_DP2_M2C_P	A6	DP2_M2C_P		
F1	MGTHRXN3_229	FMC_HPC0_DP2_M2C_N	A7	DP2_M2C_N		
G8	MGTREFCLK0P_229	FMC_HPC0_GBTCLK0_M2C_C_P ⁽¹⁾	D4	GBTCLK0_M2C_P		
G7	MGTREFCLK0N_229	FMC_HPC0_GBTCLK0_M2C_C_N ⁽¹⁾	D5	GBTCLK0_M2C_N		
E8	MGTREFCLK1P_229	NC	NA	NA		NA
E7	MGTREFCLK1N_229	NC	NA	NA		NA

Notes:

1. Series capacitor coupled.
2. MGT connections I/O standard not applicable.

Table 3-40 lists GTH bank 230 connections.

Table 3-40: ZCU102 GTH Bank 230 Interface Connections

XCZU9EG (U1) Pin	XCZU9EG (U1) Pin Name	Schematic Net Name ⁽²⁾	Connected To		
			Pin No.	Pin Name	Device
E4	MGHTXP0_230	SFP0_TX_P	RT18	RT_TD_P	QUAD SFP P2
E3	MGHTXN0_230	SFP0_TX_N	RT19	RT_TD_N	
D2	MGTHRX0_230	SFP0_RX_P	RT13	RT_RD_P	
D1	MGTHRXN0_230	SFP0_RX_N	RT12	RT_RD_N	
D6	MGHTXP1_230	SFP1_TX_P	RL18	RL_TD_P	
D5	MGHTXN1_230	SFP1_TX_N	RL19	RL_TD_N	
C4	MGTHRX1_230	SFP1_RX_P	RL13	RL_RD_P	
C3	MGTHRXN1_230	SFP1_RX_N	RL12	RL_RD_N	
B6	MGHTXP2_230	SFP2_TX_P	LT18	LT_TD_P	
B5	MGHTXN2_230	SFP2_TX_N	LT19	LT_TD_N	
B2	MGTHRX2_230	SFP2_RX_P	LT13	LT_RD_P	
B1	MGTHRXN2_230	SFP2_RX_N	LT12	LT_RD_N	
A8	MGHTXP3_230	SFP3_TX_P	LL18	LL_TD_P	
A7	MGHTXN3_230	SFP3_TX_N	LL19	LL_TD_N	
A4	MGTHRX3_230	SFP3_RX_P	LL13	LL_RD_P	
A3	MGTHRXN3_230	SFP3_RX_N	LL12	LL_RD_N	
C8	MGTREFCLK0P_230	USER_MGT_SI570_CLOCK2_C_P ⁽¹⁾	13	Q2_P	SI53340 ⁽³⁾ BUFF. U51
C7	MGTREFCLK0N_230	USER_MGT_SI570_CLOCK2_C_N ⁽¹⁾	14	Q2_N	
B10	MGTREFCLK1P_230	SFP_SI5328_OUT_C_P ⁽¹⁾	28	CLKOUT1_P	SI5328B U20
B9	MGTREFCLK1N_230	SFP_SI5328_OUT_C_N ⁽¹⁾	29	CLKOUT1_N	

Notes:

1. Series capacitor coupled.
2. MGT connections I/O standard not applicable.
3. U51 buffer driven by SI570 U56 (156.250 MHz default).

For additional information on GTH transceivers, see the *UltraScale Architecture GTH Transceivers User Guide* (UG576) [Ref 7]. For additional information about UltraScale FPGA PCIe functionality, see the *UltraScale Architecture Gen3 Integrated Block for PCI Express LogiCORE IP Product Guide* (PG156) [Ref 8]. Additional information about the PCI Express standard is available at the PCI Express website [Ref 26].

PS-Side: GTR Transceivers

[Figure 2-1, callout 1]

The PS-side GTR transceivers are shared through on-board bidirectional 2:1 multiplexer/de-multiplexer switches U125-U128 (Pericom PI2DBS6212 [Ref 27]) capable of 6.5 Gb/s operation (see Figure 3-37).

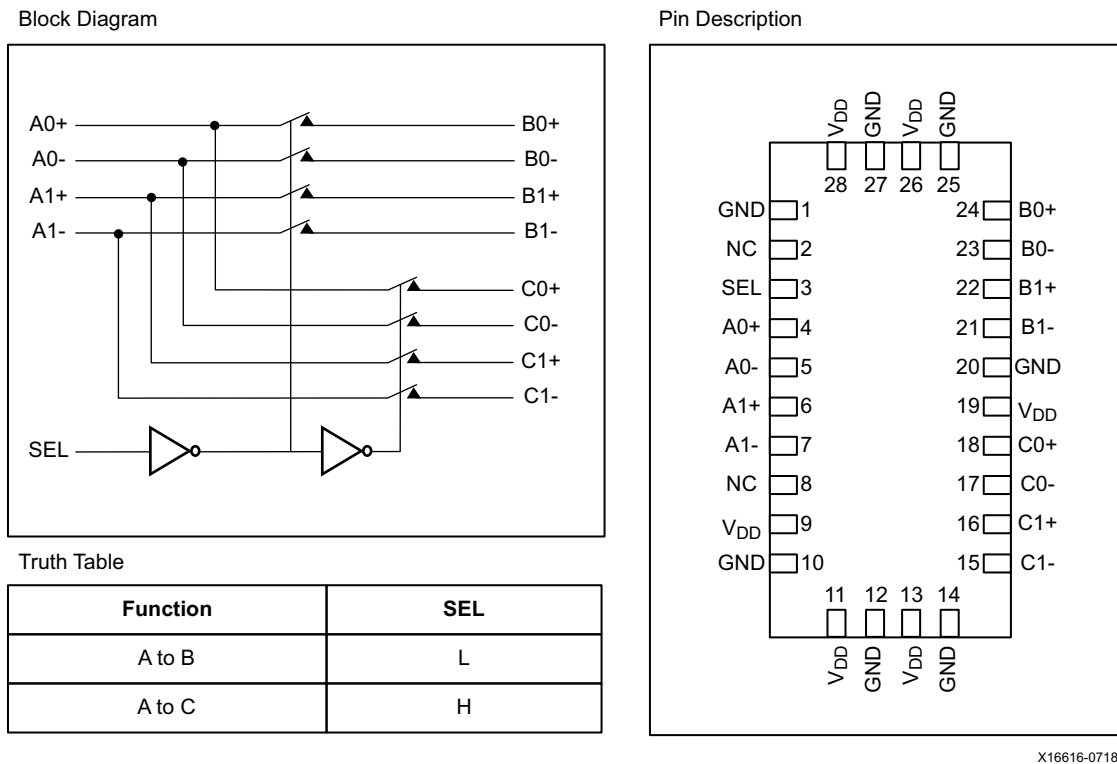

Figure 3-37: Pericom GTR Switch Block Diagram

The external GT-switch selection must be set by the user to ensure consistency with the ZU9EG's internal GT interconnect matrix (ICM) settings. There are PS-side MIO GPIO(s) that control the Pericom GT switch settings via PS-side I2C0 and the external GPIO port expander.

The functionality of each ZU9EG GTR lane is controlled through the MPSoC's ICM and is defined in the *Zynq UltraScale+ MPSoC Technical Reference Manual (UG1085)* [Ref 3]. [Table 3-41](#) lists the interconnect matrix (ICM). [Table 3-42](#) lists the interconnect matrix settings and GTR lane functionality.

Table 3-41: XCZU9EG Interconnect Matrix

Protocol	PHY Lane 0	PHY Lane 1	PHY Lane 2	PHY Lane 3
PCIe	PCIe.0	PCIe.0	PCIe.0	PCIe.0
SATA	SATA.0	SATA.1	SATA.0	SATA.1
USB0	USB0	USB0	USB0	
USB1				USB1
DisplayPort	DP.1	DP.0	DP.1	DP.0
SGMII0	SGMII0			
SGMII1		SGMII1		
SGMII2			SGMII2	
SGMII3				SGMII3

Table 3-42: Interconnect Matrix Settings and GTR Lane Functionality

Protocol	Values
Power down	3`h0
PCIe	3`h1
SATA	3`h2
USB	3`h3
DisplayPort	3`h4
SGMII	3`h5

The GTR selections provided with GT switch topology shown in [Figure 3-38](#) are:

1. PCIe Gen2/1 x4
2. DisplayPort (2-Lanes), USB, SATA
3. PCIe Gen2/1 x2, USB, SATA
4. PCIe Gen2/1 x1, DisplayPort (1-Lane), USB, SATA

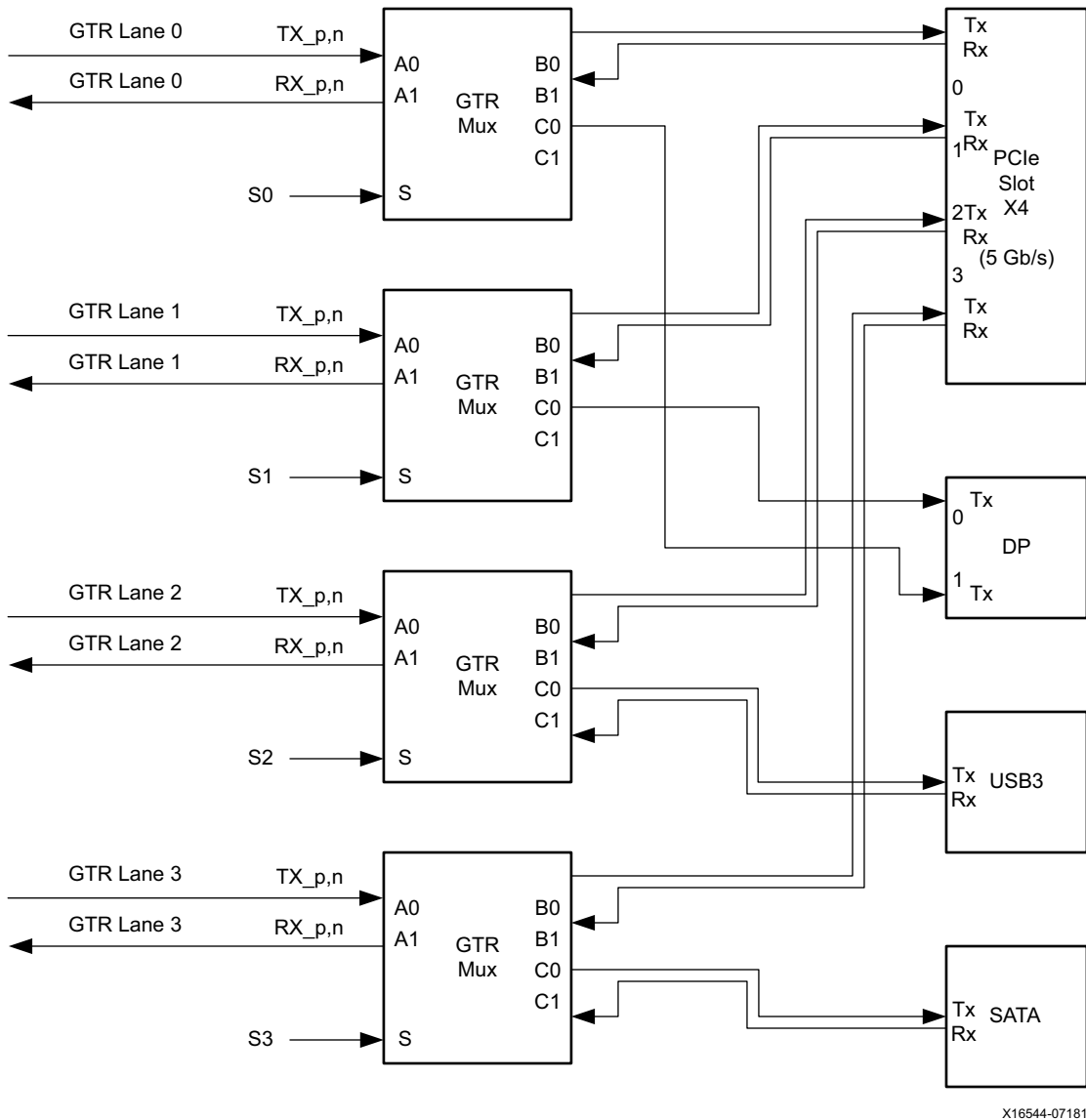

Figure 3-38: GTR External Switch Connectivity

The ICM settings for lane functionality must be set consistent with the external U125 Pericom PI2DBS6212 GTR multiplexer settings to provide appropriate functionality on the connectors wired to the PS-side GTR transceivers. The external GTR multiplexer selection is controlled by the PS-side I2C0 GPIO port expander (U97) connected to the multiplexer's "S" input. S = 0 connects the A input to the B output, whereas S = 1, connects the A input to the

C output. The "S" select logic is implemented with GPIO pins to support the settings listed in [Table 3-43](#).

Table 3-43: Supported GTR Connector Functionality

SEL (S3,2,1,0)	ICM Settings (Lane 0,1,2, 3)	PCIe Connector	DP Connector	USB Connector	SATA Connector
0000	PCIe.0, PCIe.1, PCIe.2, PCIe.3	PCIe Gen2 x4	N.C.	N.C.	N.C.
1111	DP.1, DP.0, USB, SATA	N.C.	DP.0, DP.1	USB0	SATA1
1100	PCIe.0, PCIe.1, USB, SATA	PCIe Gen2 x2	N.C.	USB0	SATA1
1110	PCIe.0, DP.0, USB, SATA	PCIe Gen2 x1	DP.0	USB0	SATA1

PCIe (MIO 31)

The ZCU102 hosts a 4-lane PCIe root port connector similar to those commonly used on many micro-ATX motherboards. The PS-side GTR transceivers can be set to provide a PCI Express interface that operates at GEN2 speeds with a width of 1-lane (x1), 2-lanes (x2), or 4-lanes (x4).

The Zynq UltraScale+ MPSoC contains an integrated block for PCI Express interface based on the PCIe base v2.1 specification. The PS-side, PCIe reset signal (PS Bank 501 MIO31 pin J22) is wired to the PCIe Gen2 x4 root port slot P1. This MIO pin is an output for Root Port mode operation. The primary purpose of the ZCU102 is for PCIe root port operation.

PCI Express Root Port Slot

[[Figure 2-1](#), callout 35]

Production ZCU102s implement an x8 PCIe connector P1 supporting x4 PCIe. This allows for flexibility so the ZCU102 can accommodate PCIe boards that are designed for up to x8 without requiring an x8-to-x4 PCIe lane reducer.

The PCI Express connector P1 performs data transfers at the rate of 5.0 GT/s for Gen2 applications. The PCIe clock is routed as a 100Ω differential pair. The PCIe transmit and receive signal data paths are routed with a differential characteristic impedance of 85 ±10% with an insertion loss of <4 dB up to 8 GHz. The XCZU9EG-L2FFVB1156E (-2 speed grade) device included with the ZCU102 board supports up to Gen3 x4. The PCIe reference clock output is wired to the P1 connector. PCIE_SLOT_CLK_P is connected to clock driver U69

Si5341B pin 38, and the _N net is connected to pin 37. The PCI Express clock circuit is shown in Figure 3-8. PCIe 4-lane connector P1 is shown in Figure 3-39.

The ZCU102 board’s PCIe Host connector supports power requirements consistent with the PCI Express® Card Electromechanical Specification Revision 2.0 PCIe add-in cards up to 25W max (2.1A max on PCIe +12V and 3.0A max on PCIe +3.3V).

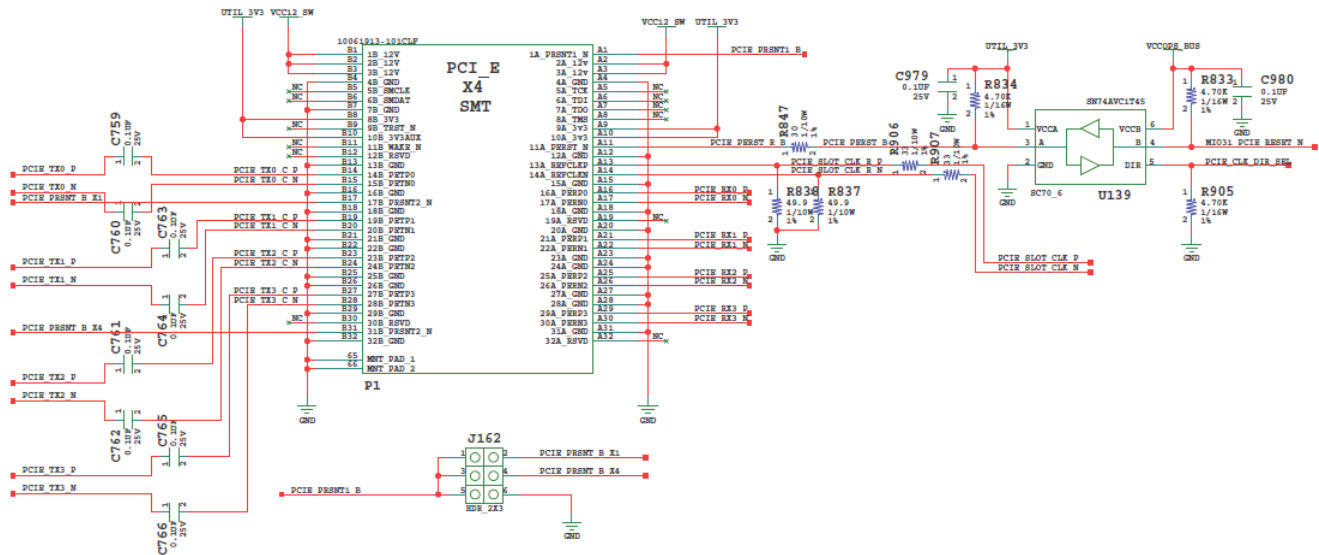

Figure 3-39: PCIe Connector P1

The 4-lane PCIe connector lane TX/RX nets are wired to the MPSoC U1 PS GTR Bank 505 transceiver channels through four 2-to-1 Pericom PI2DBS6212 [Ref 27] high speed multiplexers.

FPGA Mezzanine Card Interface

[Figure 2-1, callouts 31, 32]

The ZCU102 evaluation board supports the VITA 57.1 FPGA mezzanine card (FMC) specification [Ref 29] by providing subset implementations of high pin count connectors at J5 (HPC0) and J4 (HPC1). HPC connectors use a 10 x 40 form factor, populated with 400 pins. The connectors are keyed so that a mezzanine card, when installed in either of these FMC connectors on the ZCU102 evaluation board, faces away from the board.

FMC HPC0 Connector J5

[Figure 2-1, callout 31]

The FMC connector at J5 (HPC0) implements a subset of the full FMC HPC connectivity:

- 68 single-ended, or 34 differential user-defined pairs (34 LA pairs: LA[00:33])

- Eight GTH transceiver DP differential pairs
- Two GBTCLK differential clocks
- 159 ground and 15 power connections

The ZCU102 board FMC VADJ voltage VADJ_FMC_BUS for the J5 (HPC0) and J4 (HPC1) FMC connectors is determined by the MAX15301 U63 voltage regulator described in [ZCU102 Board Power System](#). The valid values of the VADJ_FMC rail are 1.2V, 1.5V, and 1.8V. The HPC0 J5 connections to XCZU9EG U1 are shown in [Table 3-44](#) through [Table 3-48](#).

Table 3-44: J5 HPC0 FMC Section A and B Connections to XCZU9EG U1

J5 Pin	Schematic Net Name	I/O Standard	U1 Pin	J5 Pin	Schematic Net Name	I/O Standard	U1 Pin
A2	FMC_HPC0_DP1_M2C_P		J4	B1	NC		
A3	FMC_HPC0_DP1_M2C_N		J3	B4	NC		
A6	FMC_HPC0_DP2_M2C_P		F2	B5	NC		
A7	FMC_HPC0_DP2_M2C_N		F1	B8	NC		
A10	FMC_HPC0_DP3_M2C_P		K2	B9	NC		
A11	FMC_HPC0_DP3_M2C_N		K1	B12	FMC_HPC0_DP7_M2C_P		M2
A14	FMC_HPC0_DP4_M2C_P		L4	B13	FMC_HPC0_DP7_M2C_N		M1
A15	FMC_HPC0_DP4_M2C_N		L3	B16	FMC_HPC0_DP6_M2C_P		T2
A18	FMC_HPC0_DP5_M2C_P		P2	B17	FMC_HPC0_DP6_M2C_N		T1
A19	FMC_HPC0_DP5_M2C_N		P1	B20	FMC_HPC0_GBTCLK1_M2C_P ⁽¹⁾		L8
A22	FMC_HPC0_DP1_C2M_P		H6	B21	FMC_HPC0_GBTCLK1_M2C_N ⁽¹⁾		L7
A23	FMC_HPC0_DP1_C2M_N		H5	B24	NC		
A26	FMC_HPC0_DP2_C2M_P		F6	B25	NC		
A27	FMC_HPC0_DP2_C2M_N		F5	B28	NC		
A30	FMC_HPC0_DP3_C2M_P		K6	B29	NC		
A31	FMC_HPC0_DP3_C2M_N		K5	B32	FMC_HPC0_DP7_C2M_P		N4
A34	FMC_HPC0_DP4_C2M_P		M6	B33	FMC_HPC0_DP7_C2M_N		N3
A35	FMC_HPC0_DP4_C2M_N		M5	B36	FMC_HPC0_DP6_C2M_P		R4
A38	FMC_HPC0_DP5_C2M_P		P6	B37	FMC_HPC0_DP6_C2M_N		R3
A39	FMC_HPC0_DP5_C2M_N		P5	B40	NC		

Notes:

1. Series capacitor coupled to XCZU9EG U1 pin.

Table 3-45: J5 HPC0 FMC Section C and D Connections to XCZU9EG U1

J5 Pin	Schematic Net Name	I/O Standard	U1 Pin	J5 Pin	Schematic Net Name	I/O Standard	U1 Pin
C2	FMC_HPC0_DP0_C2M_P		G4	D1	VADJ_FMC_PGOOD ⁽⁵⁾		J4.D1, U63.32, U66.6
C3	FMC_HPC0_DP0_C2M_N		G3	D4	FMC_HPC0_GBTCLK0_M2C_P ⁽¹⁾		G8
C6	FMC_HPC0_DP0_M2C_P		H2	D5	FMC_HPC0_GBTCLK0_M2C_N ⁽¹⁾		G7
C7	FMC_HPC0_DP0_M2C_N		H1	D8	FMC_HPC0_LA01_CC_P	LVC MOS18	AB4
C10	FMC_HPC0_LA06_P	LVC MOS18	AC2	D9	FMC_HPC0_LA01_CC_N	LVC MOS18	AC4
C11	FMC_HPC0_LA06_N	LVC MOS18	AC1	D11	FMC_HPC0_LA05_P	LVC MOS18	AB3
C14	FMC_HPC0_LA10_P	LVC MOS18	W5	D12	FMC_HPC0_LA05_N	LVC MOS18	AC3
C15	FMC_HPC0_LA10_N	LVC MOS18	W4	D14	FMC_HPC0_LA09_P	LVC MOS18	W2
C18	FMC_HPC0_LA14_P	LVC MOS18	AC7	D15	FMC_HPC0_LA09_N	LVC MOS18	W1
C19	FMC_HPC0_LA14_N	LVC MOS18	AC6	D17	FMC_HPC0_LA13_P	LVC MOS18	AB8
C22	FMC_HPC0_LA18_CC_P	LVC MOS18	N9	D18	FMC_HPC0_LA13_N	LVC MOS18	AC8
C23	FMC_HPC0_LA18_CC_N	LVC MOS18	N8	D20	FMC_HPC0_LA17_CC_P	LVC MOS18	P11
C26	FMC_HPC0_LA27_P	LVC MOS18	M10	D21	FMC_HPC0_LA17_CC_N	LVC MOS18	N11
C27	FMC_HPC0_LA27_N	LVC MOS18	L10	D23	FMC_HPC0_LA23_P	LVC MOS18	L16
C30	FMC_HPC0_IIC_SCL ⁽²⁾			D24	FMC_HPC0_LA23_N	LVC MOS18	K16
C31	FMC_HPC0_IIC_SDA ⁽²⁾			D26	FMC_HPC0_LA26_P	LVC MOS18	L15
C34	GND			D27	FMC_HPC0_LA26_N	LVC MOS18	K15
C35	VCC12_SW			D29	FMC_HPC0_TCK_BUF ⁽³⁾		
C37	VCC12_SW			D30	FPGA_TDO_FMC_TDI_BUF ⁽⁴⁾		
C39	UTIL_3V3			D31	FMC_HPC0_TDO_HPC1_TDI ⁽³⁾⁽⁴⁾		
				D32	UTIL_3V3_10A		
				D33	FMC_HPC0_TMS_BUF (3)		
				D34	NC		
				D35	GND		
				D36	UTIL_3V3		
				D38	UTIL_3V3		
				D40	UTIL_3V3		

Notes:

- Series capacitor coupled to XCZU9EG U1 pin.
- Connected to I2C switch U135 pins 4 and 5.
- XCZU9EG U1 JTAG TCK, TMS, TDO pins R25, R24, T25 are buffered by U48 SN74AVC8T245.
- J5 HPC0 TDO-TDI connections to U27 HPC0 FMC JTAG bypass switch (N.C. normally-closed/bypassing J5 until an FMC card is plugged onto J5).
- Sourced from VADJ_FMC_BUS voltage regulator U63 MAX15301 pin 32 power good output signal.

Table 3-46: J5 HPC0 FMC Section E and F Connections to XCZU9EG U1

J5 Pin	Schematic Net Name	I/O Standard	U1 Pin	J5 Pin	Schematic Net Name	I/O Standard	U1 Pin
E2	NC			F1	FMC_HPC0_PG_M2C	P/U to 3.3V via R277	
E3	NC			F4	NC		
E6	NC			F5	NC		
E7	NC			F7	NC		
E9	NC			F8	NC		
E10	NC			F10	NC		
E12	NC			F11	NC		
E13	NC			F13	NC		
E15	NC			F14	NC		
E16	NC			F16	NC		
E18	NC			F17	NC		
E19	NC			F19	NC		
E21	NC			F20	NC		
E22	NC			F22	NC		
E24	NC			F23	NC		
E25	NC			F25	NC		
E27	NC			F26	NC		
E28	NC			F28	NC		
E30	NC			F29	NC		
E31	NC			F31	NC		
E33	NC			F32	NC		
E34	NC			F34	NC		
E36	NC			F35	NC		
E37	NC			F37	NC		
E39	VADJ_FMC_BUS			F38	NC		
				F40	VADJ_FMC_BUS		

Table 3-47: J5 HPC0 FMC Section G and H Connections to XCZU9EG U1

J5 Pin	Schematic Net Name	I/O Standard	U1 Pin	J5 Pin	Schematic Net Name	I/O Standard	U1 Pin
G2	FMC_HPC0_CLK1_M2C_P	LVDS	T8	H1	NC		
G3	FMC_HPC0_CLK1_M2C_N	LVDS	R8	H2	FMC_HPC0_PRSNT_M2C_B ⁽¹⁾		
G6	FMC_HPC0_LA00_CC_P	LVC MOS18	Y4	H4	FMC_HPC0_CLK0_M2C_P	LVDS	AA7
G7	FMC_HPC0_LA00_CC_N	LVC MOS18	Y3	H5	FMC_HPC0_CLK0_M2C_N	LVDS	AA6
G9	FMC_HPC0_LA03_P	LVC MOS18	Y2	H7	FMC_HPC0_LA02_P	LVC MOS18	V2
G10	FMC_HPC0_LA03_N	LVC MOS18	Y1	H8	FMC_HPC0_LA02_N	LVC MOS18	V1
G12	FMC_HPC0_LA08_P	LVC MOS18	V4	H10	FMC_HPC0_LA04_P	LVC MOS18	AA2
G13	FMC_HPC0_LA08_N	LVC MOS18	V3	H11	FMC_HPC0_LA04_N	LVC MOS18	AA1
G15	FMC_HPC0_LA12_P	LVC MOS18	W7	H13	FMC_HPC0_LA07_P	LVC MOS18	U5
G16	FMC_HPC0_LA12_N	LVC MOS18	W6	H14	FMC_HPC0_LA07_N	LVC MOS18	U4
G18	FMC_HPC0_LA16_P	LVC MOS18	Y12	H16	FMC_HPC0_LA11_P	LVC MOS18	AB6
G19	FMC_HPC0_LA16_N	LVC MOS18	AA12	H17	FMC_HPC0_LA11_N	LVC MOS18	AB5
G21	FMC_HPC0_LA20_P	LVC MOS18	N13	H19	FMC_HPC0_LA15_P	LVC MOS18	Y10
G22	FMC_HPC0_LA20_N	LVC MOS18	M13	H20	FMC_HPC0_LA15_N	LVC MOS18	Y9
G24	FMC_HPC0_LA22_P	LVC MOS18	M15	H22	FMC_HPC0_LA19_P	LVC MOS18	L13
G25	FMC_HPC0_LA22_N	LVC MOS18	M14	H23	FMC_HPC0_LA19_N	LVC MOS18	K13
G27	FMC_HPC0_LA25_P	LVC MOS18	M11	H25	FMC_HPC0_LA21_P	LVC MOS18	P12
G28	FMC_HPC0_LA25_N	LVC MOS18	L11	H26	FMC_HPC0_LA21_N	LVC MOS18	N12
G30	FMC_HPC0_LA29_P	LVC MOS18	U9	H28	FMC_HPC0_LA24_P	LVC MOS18	L12
G31	FMC_HPC0_LA29_N	LVC MOS18	U8	H29	FMC_HPC0_LA24_N	LVC MOS18	K12
G33	FMC_HPC0_LA31_P	LVC MOS18	V8	H31	FMC_HPC0_LA28_P	LVC MOS18	T7
G34	FMC_HPC0_LA31_N	LVC MOS18	V7	H32	FMC_HPC0_LA28_N	LVC MOS18	T6
G36	FMC_HPC0_LA33_P	LVC MOS18	V12	H34	FMC_HPC0_LA30_P	LVC MOS18	V6
G37	FMC_HPC0_LA33_N	LVC MOS18	V11	H35	FMC_HPC0_LA30_N	LVC MOS18	U6
G39	VADJ_FMC_BUS			H37	FMC_HPC0_LA32_P	LVC MOS18	U11
				H38	FMC_HPC0_LA32_N	LVC MOS18	T11
				H40	VADJ_FMC_BUS		

Notes:

1. FMC_HPC0_PRSNT_M2C_B is the HPC FMC JTAG bypass switch U27.4 OE control signal is driven from I2C I/O expander U97.13.

Table 3-48: J5 HPC0 FMC Section J and K Connections to XCZU9EG U1

J5 Pin	Schematic Net Name	I/O Standard	U1 Pin	J5 Pin	Schematic Net Name	I/O Standard	U1 Pin
J2	NC			K1	NC		
J3	NC			K4	NC		
J6	NC			K5	NC		
J7	NC			K7	NC		
J9	NC			K8	NC		
J10	NC			K10	NC		
J12	NC			K11	NC		
J13	NC			K13	NC		
J15	NC			K14	NC		
J16	NC			K16	NC		
J18	NC			K17	NC		
J19	NC			K19	NC		
J21	NC			K20	NC		
J22	NC			K22	NC		
J24	NC			K23	NC		
J25	NC			K25	NC		
J27	NC			K26	NC		
J28	NC			K28	NC		
J30	NC			K29	NC		
J31	NC			K31	NC		
J33	NC			K32	NC		
J34	NC			K34	NC		
J36	NC			K35	NC		
J37	NC			K37	NC		
J39	NC			K38	NC		
				K40	NC		

FMC HPC1 Connector J4

[Figure 2-1, callout 32]

The FMC connector at J4 (HPC1) implements a subset of the full FMC HPC connectivity:

- 60 single-ended, or 30 differential user-defined pairs (LA[00:29])
- Eight GTH transceiver DP differential pairs
- Two GBTCLK differential clocks

- 159 ground and 15 power connections

The ZCU102 board FMC VADJ voltage VADJ_FMC_BUS for the J5 (HPC0) and J4 (HPC1) FMC connectors is determined by the MAX15301 U63 voltage regulator described in [ZCU102 Board Power System](#). The valid values of the VADJ_FMC rail are 1.2V, 1.5V, and 1.8V. The HPC1 J4 connections to XCZU9EG U1 are shown in [Table 3-49](#) through [Table 3-53](#).

Table 3-49: J4 HPC1 FMC Section A and B Connections to XCZU9EG U1

J5 Pin	Schematic Net Name	I/O Standard	U1 Pin	J5 Pin	Schematic Net Name	I/O Standard	U1 Pin
A2	FMC_HPC1_DP1_M2C_P		D33	B1	NC		
A3	FMC_HPC1_DP1_M2C_N		D34	B4	NC		
A6	FMC_HPC1_DP2_M2C_P		C31	B5	NC		
A7	FMC_HPC1_DP2_M2C_N		C32	B8	NC		
A10	FMC_HPC1_DP3_M2C_P		B33	B9	NC		
A11	FMC_HPC1_DP3_M2C_N		B34	B12	FMC_HPC1_DP7_M2C_P		F33
A14	FMC_HPC1_DP4_M2C_P		L31	B13	FMC_HPC1_DP7_M2C_N		F34
A15	FMC_HPC1_DP4_M2C_N		L32	B16	FMC_HPC1_DP6_M2C_P		H33
A18	FMC_HPC1_DP5_M2C_P		K33	B17	FMC_HPC1_DP6_M2C_N		H34
A19	FMC_HPC1_DP5_M2C_N		K34	B20	FMC_HPC1_GBTCLK1_M2C_P ⁽¹⁾		E27
A22	FMC_HPC1_DP1_C2M_P		D29	B21	FMC_HPC1_GBTCLK1_M2C_N ⁽¹⁾		E28
A23	FMC_HPC1_DP1_C2M_N		D30	B24	NC		
A26	FMC_HPC1_DP2_C2M_P		B29	B25	NC		
A27	FMC_HPC1_DP2_C2M_N		B30	B28	NC		
A30	FMC_HPC1_DP3_C2M_P		A31	B29	NC		
A31	FMC_HPC1_DP3_C2M_N		A32	B32	FMC_HPC1_DP7_C2M_P		G31
A34	FMC_HPC1_DP4_C2M_P		K29	B33	FMC_HPC1_DP7_C2M_N		G32
A35	FMC_HPC1_DP4_C2M_N		K30	B36	FMC_HPC1_DP6_C2M_P		H29
A38	FMC_HPC1_DP5_C2M_P		J31	B37	FMC_HPC1_DP6_C2M_N		H30
A39	FMC_HPC1_DP5_C2M_N		J32	B40	NC		

Notes:

1. Series capacitor coupled to XCZU9EG U1 pin.

Table 3-50: J4 HPC1 FMC Section C and D Connections to XCZU9EG U1

J5 Pin	Schematic Net Name	I/O Standard	U1 Pin	J5 Pin	Schematic Net Name	I/O Standard	U1 Pin
C2	FMC_HPC1_DP0_C2M_P		F29	D1	VADJ_FMC_PGOOD ⁽⁵⁾		J5.D1, U63.32, U66.6
C3	FMC_HPC1_DP0_C2M_N		F30	D4	FMC_HPC1_GBTCLK0_M2C_P ⁽¹⁾		G27
C6	FMC_HPC1_DP0_M2C_P		E31	D5	FMC_HPC1_GBTCLK0_M2C_N ⁽¹⁾		G28
C7	FMC_HPC1_DP0_M2C_N		E32	D8	FMC_HPC1_LA01_CC_P	LVC MOS18	AJ6
C10	FMC_HPC1_LA06_P	LVC MOS18	AH2	D9	FMC_HPC1_LA01_CC_N	LVC MOS18	AJ5
C11	FMC_HPC1_LA06_N	LVC MOS18	AJ2	D11	FMC_HPC1_LA05_P	LVC MOS18	AG3
C14	FMC_HPC1_LA10_P	LVC MOS18	AH4	D12	FMC_HPC1_LA05_N	LVC MOS18	AH3
C15	FMC_HPC1_LA10_N	LVC MOS18	AJ4	D14	FMC_HPC1_LA09_P	LVC MOS18	AE2
C18	FMC_HPC1_LA14_P	LVC MOS18	AH7	D15	FMC_HPC1_LA09_N	LVC MOS18	AE1
C19	FMC_HPC1_LA14_N	LVC MOS18	AH6	D17	FMC_HPC1_LA13_P	LVC MOS18	AG8
C22	FMC_HPC1_LA18_CC_P	LVC MOS18	Y8	D18	FMC_HPC1_LA13_N	LVC MOS18	AH8
C23	FMC_HPC1_LA18_CC_N	LVC MOS18	Y7	D20	FMC_HPC1_LA17_CC_P	LVC MOS18	Y5
C26	FMC_HPC1_LA27_P	LVC MOS18	U10	D21	FMC_HPC1_LA17_CC_N	LVC MOS18	AA5
C27	FMC_HPC1_LA27_N	LVC MOS18	T10	D23	FMC_HPC1_LA23_P	LVC MOS18	AE12
C30	FMC_HPC1_IIC_SCL ⁽²⁾			D24	FMC_HPC1_LA23_N	LVC MOS18	AF12
C31	FMC_HPC1_IIC_SDA ⁽²⁾			D26	FMC_HPC1_LA26_P	LVC MOS18	T12
C34	GND			D27	FMC_HPC1_LA26_N	LVC MOS18	R12
C35	VCC12_SW			D29	FMC_HPC1_TCK_BUF ⁽³⁾		
C37	VCC12_SW			D30	FPGA_TDO_FMC_TDI_BUF ⁽⁴⁾		
C39	UTIL_3V3			D31	FMC_HPC1_TDO_HPC1_TDI ⁽³⁾⁽⁴⁾		
				D32	UTIL_3V3_10A		
				D33	FMC_HPC1_TMS_BUF ⁽³⁾		
				D34	NC		
				D35	GND		
				D36	UTIL_3V3		
				D38	UTIL_3V3		
				D40	UTIL_3V3		

Notes:

1. Series capacitor coupled to XCZU9EG U1 pin.
2. Connected to I2C switch U135 pins 6 and 7.
3. XCZU9EG U1 JTAG TCK, TMS, TDO pins R25, R24, T25 are buffered by U48 SN74AVC8T245.
4. J5 HPC0 TDO-TDI connections to U27 HPC0 FMC JTAG bypass switch (N.C. normally-closed/bypassing J5 until an FMC card is plugged onto J5).
5. Sourced from VADJ_FMC_BUS voltage regulator U63 MAX15301 pin 32 power good output signal.

Table 3-51: J4 HPC1 FMC Section E and F Connections to XCZU9EG U1

J5 Pin	Schematic Net Name	I/O Standard	U1 Pin	J5 Pin	Schematic Net Name	I/O Standard	U1 Pin
E2	NC			F1	FMC_HPC0_PG_M2C		P/U to 3.3V via R250
E3	NC			F4	NC		
E6	NC			F5	NC		
E7	NC			F7	NC		
E9	NC			F8	NC		
E10	NC			F10	NC		
E12	NC			F11	NC		
E13	NC			F13	NC		
E15	NC			F14	NC		
E16	NC			F16	NC		
E18	NC			F17	NC		
E19	NC			F19	NC		
E21	NC			F20	NC		
E22	NC			F22	NC		
E24	NC			F23	NC		
E25	NC			F25	NC		
E27	NC			F26	NC		
E28	NC			F28	NC		
E30	NC			F29	NC		
E31	NC			F31	NC		
E33	NC			F32	NC		
E34	NC			F34	NC		
E36	NC			F35	NC		
E37	NC			F37	NC		
E39	VADJ_FMC_BUS			F38	NC		
				F40	VADJ_FMC_BUS		

Table 3-52: J4 HPC1 FMC Section G and H Connections to XCZU9EG U1

J5 Pin	Schematic Net Name	I/O Standard	U1 Pin	J5 Pin	Schematic Net Name	I/O Standard	U1 Pin
G2	FMC_HPC1_CLK1_M2C_P	LVDS	P10	H1	NC		
G3	FMC_HPC1_CLK1_M2C_N	LVDS	P9	H2	FMC_HPC1_PRSNT_M2C_B ⁽¹⁾		
G6	FMC_HPC1_LA00_CC_P	LVC MOS18	AE5	H4	FMC_HPC1_CLK0_M2C_P	LVDS	AE7
G7	FMC_HPC1_LA00_CC_N	LVC MOS18	AF5	H5	FMC_HPC1_CLK0_M2C_N	LVDS	AF7
G9	FMC_HPC1_LA03_P	LVC MOS18	AH1	H7	FMC_HPC1_LA02_P	LVC MOS18	AD2
G10	FMC_HPC1_LA03_N	LVC MOS18	AJ1	H8	FMC_HPC1_LA02_N	LVC MOS18	AD1
G12	FMC_HPC1_LA08_P	LVC MOS18	AE3	H10	FMC_HPC1_LA04_P	LVC MOS18	AF2
G13	FMC_HPC1_LA08_N	LVC MOS18	AF3	H11	FMC_HPC1_LA04_N	LVC MOS18	AF1
G15	FMC_HPC1_LA12_P	LVC MOS18	AD7	H13	FMC_HPC1_LA07_P	LVC MOS18	AD4
G16	FMC_HPC1_LA12_N	LVC MOS18	AD6	H14	FMC_HPC1_LA07_N	LVC MOS18	AE4
G18	FMC_HPC1_LA16_P	LVC MOS18	AG10	H16	FMC_HPC1_LA11_P	LVC MOS18	AE8
G19	FMC_HPC1_LA16_N	LVC MOS18	AG9	H17	FMC_HPC1_LA11_N	LVC MOS18	AF8
G21	FMC_HPC1_LA20_P	LVC MOS18	AB11	H19	FMC_HPC1_LA15_P	LVC MOS18	AD10
G22	FMC_HPC1_LA20_N	LVC MOS18	AB10	H20	FMC_HPC1_LA15_N	LVC MOS18	AE9
G24	FMC_HPC1_LA22_P	LVC MOS18	AF11	H22	FMC_HPC1_LA19_P	LVC MOS18	AA11
G25	FMC_HPC1_LA22_N	LVC MOS18	AG11	H23	FMC_HPC1_LA19_N	LVC MOS18	AA10
G27	FMC_HPC1_LA25_P	LVC MOS18	AE10	H25	FMC_HPC1_LA21_P	LVC MOS18	AC12
G28	FMC_HPC1_LA25_N	LVC MOS18	AF10	H26	FMC_HPC1_LA21_N	LVC MOS18	AC11
G30	FMC_HPC1_LA29_P	LVC MOS18	W12	H28	FMC_HPC1_LA24_P	LVC MOS18	AH12
G31	FMC_HPC1_LA29_N	LVC MOS18	W11	H29	FMC_HPC1_LA24_N	LVC MOS18	AH11
G33	FMC_HPC1_LA31_P		NC	H31	FMC_HPC1_LA28_P	LVC MOS18	T13
G34	FMC_HPC1_LA31_N		NC	H32	FMC_HPC1_LA28_N	LVC MOS18	R13
G36	FMC_HPC1_LA33_P		NC	H34	FMC_HPC1_LA30_P		NC
G37	FMC_HPC1_LA33_N		NC	H35	FMC_HPC1_LA30_N		NC
G39	VADJ_FMC_BUS			H37	FMC_HPC1_LA32_P		NC
				H38	FMC_HPC1_LA32_N		NC
				H40	VADJ_FMC_BUS		

Notes:

1. FMC_HPC0_PRSNT_M2C_B is the HPC FMC JTAG bypass switch U27.4 OE control signal is driven from I2C I/O expander U97.13.

Table 3-53: J4 HPC1 FMC Section J and K Connections to XCZU9EG U1

J5 Pin	Schematic Net Name	I/O Standard	U1 Pin	J5 Pin	Schematic Net Name	I/O Standard	U1 Pin
J2	NC			K1	NC		
J3	NC			K4	NC		
J6	NC			K5	NC		
J7	NC			K7	NC		
J9	NC			K8	NC		
J10	NC			K10	NC		
J12	NC			K11	NC		
J13	NC			K13	NC		
J15	NC			K14	NC		
J16	NC			K16	NC		
J18	NC			K17	NC		
J19	NC			K19	NC		
J21	NC			K20	NC		
J22	NC			K22	NC		
J24	NC			K23	NC		
J25	NC			K25	NC		
J27	NC			K26	NC		
J28	NC			K28	NC		
J30	NC			K29	NC		
J31	NC			K31	NC		
J33	NC			K32	NC		
J34	NC			K34	NC		
J36	NC			K35	NC		
J37	NC			K37	NC		
J39	NC			K38	NC		
				K40	NC		

See the ANSI/VITA 57.1 FPGA mezzanine card (FMC) specification [\[Ref 29\]](#) for additional information on the FPGA FMC.

Cooling Fan Connector

[Figure 2-1, near callout 42]

The XCZU9EG U1 cooling fan connector is shown in Figure 3-40. The fan turns on when the ZCU102 is powered up.

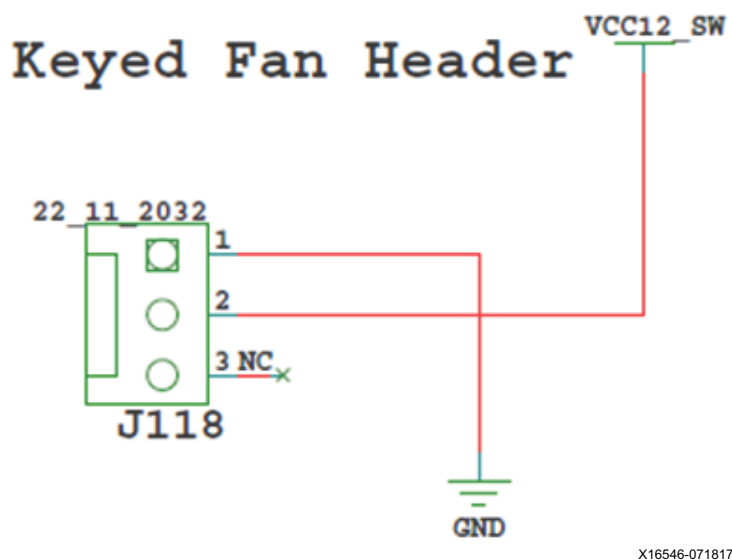

X16546-071817

Figure 3-40: ZCU102 12V Fan Header

VADJ_FMC Power Rail

The ZCU102 evaluation board implements the ANSI/VITA 57.1 section 5.5.1 IPMI support functionality. The power control of the V_{ADJ_FMC} power rail is managed by the U41 system controller. This rail powers both the FMC HPC0 (J5) and the FMC HPC1 (J4) V_{ADJ} pins, as well as the XCZU9EG HP banks 65, 66 and 67. The valid values of the V_{ADJ_FMC} rail are 1.2V, 1.5V, and 1.8V.

At power on, the system controller detects if an FMC module is connected to each interface:

- If no cards are attached to the FMC ports, the V_{ADJ} voltage is set to 1.8V.
- When one FMC card is attached, its IIC EEPROM is read to find a V_{ADJ} voltage supported by both the ZCU102 board and the FMC module, within the available choices of 1.8V, 1.5V, 1.2V, and 0.0V.
- When two FMC cards are attached with differing V_{ADJ} requirements, V_{ADJ_FMC} is set to the lowest value compatible with the ZCU102 board and the FMC modules, within the available choices of 1.8V, 1.5V, 1.2V, and 0.0V.
- If no valid information is found in an FMC card IIC EEPROM, the V_{ADJ_FMC} rail is set to 0.0V.

The system controller user interface allows the FMC IPMI routine to be overridden and an explicit value can be set for the VADJ_FMC rail. Override mode is useful for FMC mezzanine cards that do not contain valid IPMI EPROM data defined by the ANSI/VITA57.1 specification.

TI MSP430 System Controller

[Figure 2-1, callout 18]

The ZCU102 board includes an on-board MSP430 with integrated Power Advantage demo and System Controller firmware. A Host PC resident system controller user interface (SCUI) is provided on the [ZCU102 web page](#). This GUI enables you to query and control select programmable features such as clocks, FMC functionality, power systems, and the Zynq UltraScale+ MPSoC GTR selection compatible with your design. The ZCU102 web page also includes a tutorial on the SCUI (XTP433) [Ref 17] and board setup instructions (XTP435) [Ref 18]. The following briefly summarizes these instructions:

1. Ensure that the Silicon Labs VCP USB-UART drivers are installed.
2. Download the SCUI Host PC application.
3. Connect the micro-USB to ZCU102 USB-UART connector (J83).
4. Power-cycle the ZCU102.
5. Observe that SYSCTLR LED0 (DS47) blinks and LED1 DS46 is illuminated.
6. Launch the SCUI.

The SCUI GUI is shown in [Figure 3-41](#).

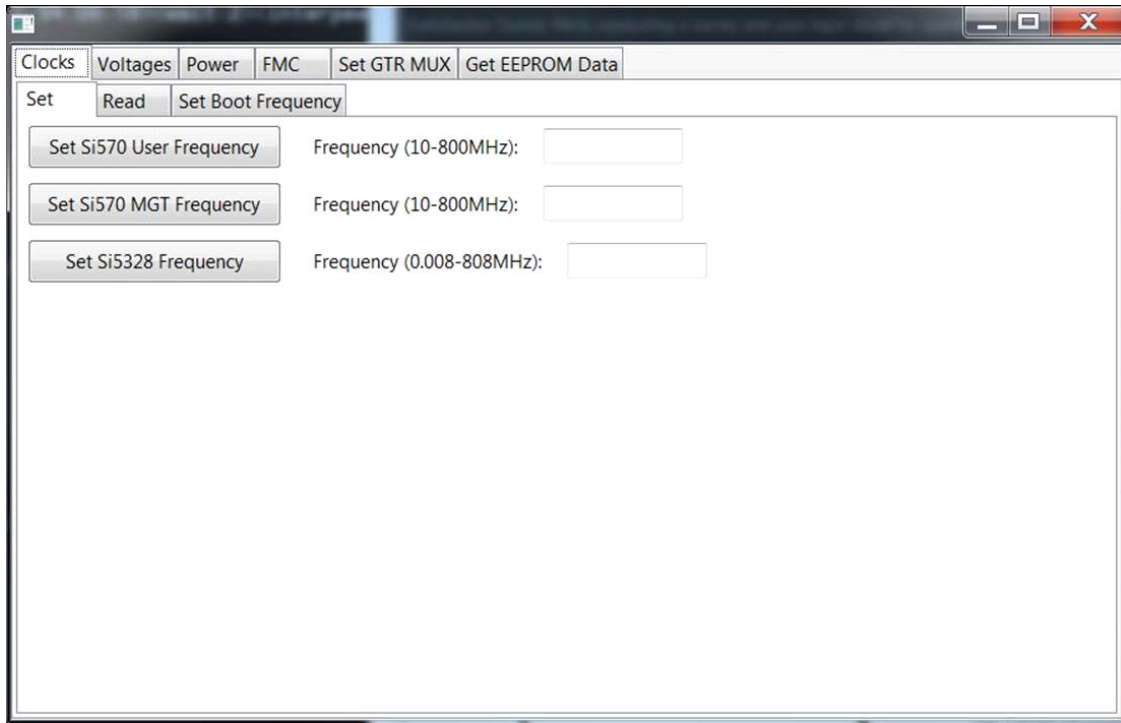

Figure 3-41: SCUI Graphical User Interface

On first use of the SCUI, go to the FMC > Set VADJ > Boot-up tab and click **USE FMC EEPROM Voltage**. The SCUI buttons gray-out during command execution and return to their original appearance when ready to accept a new command.

See the *System Controller Tutorial (XTP433)* and the *ZCU102 Software Install and Board Setup Tutorial (XTP435)* for more information on installing and using the System Controller utility.

The MSP430 uses ID resistor encoding to allow the System Controller utility awareness of which board type is active. See [Table 3-54](#) for the configuration of the ID encoding resistors R516 and R517.

Table 3-54: MSP430 Board ID Encoding

Zynq UltraScale+ Board	R516	R517
ZCU102	DNP	DNP
ZCU106	DNP	10K
Reserved	10K	DNP
Reserved	10K	10K

Note: The MSP430 firmware might be updated in the event new capability is added in the future. The MSP430 upgrade header, J164, is reserved for this purpose. Xilinx will provide information on the update procedure via future updates to XTP433 [Ref 17].

Switches

[Figure 2-1, callouts 26, 28, 30, and 44]

The ZCU102 board includes power, configuration and reset switches:

- SW1 Power On/Off slide switch (callout 28)
- SW5 (PS_PROG_B), active-Low pushbutton (callout 30)
- SW3 (SRST_B), active-Low pushbutton (callout 26)
- SW4 (POR_B), active-Low pushbutton (callout 26)
- SW6 U1 MPSoC PS bank 503 4-pole mode DIP switch (callout 44)

Power On/Off Slide Switch

[Figure 2-1, callout 28]

The ZCU102 board power switch is SW1. Sliding the switch actuator from the *Off* to *On* position applies 12V power from J52, a 6-pin mini-fit connector. Green LED DS2 illuminates when the ZCU102 board power is on. See [ZCU102 Board Power System](#) for details on the on-board power system.



CAUTION! Do NOT plug a PC ATX power supply 6-pin connector into J52 on the ZCU102 board. The ATX 6-pin connector has a different pin-out than J52. Connecting an ATX 6-pin connector into J52 damages the ZCU102 board and voids the board warranty.

Figure 3-42 shows the power connector J52, power switch SW1, and LED indicator DS2.

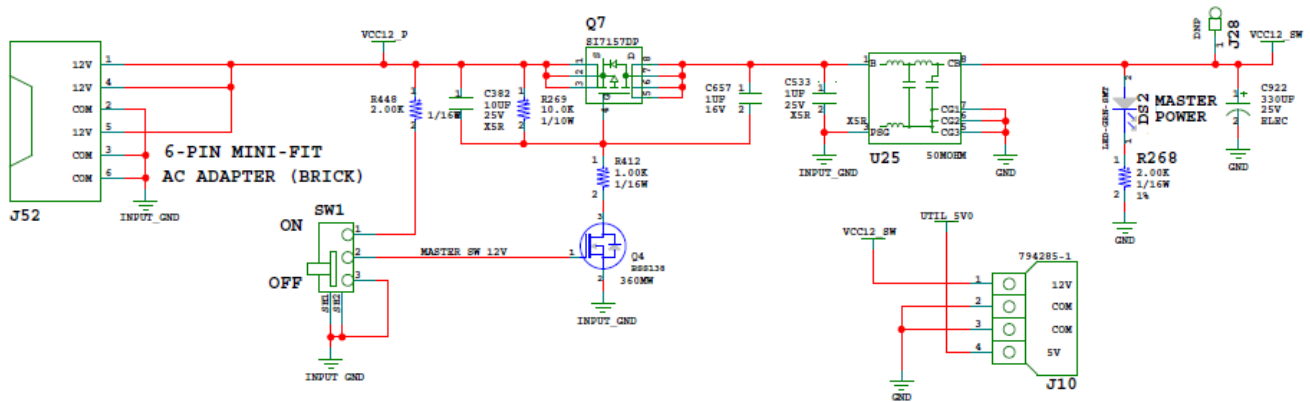

X16548-071817

Figure 3-42: Power On/Off Switch SW1

Program_B Pushbutton

[Figure 2-1, callout 30]

PS_PROG_B pushbutton switch SW5 grounds the XCZU9EG MPSoC PS_PROG_B pin U21 when pressed (see Figure 3-43). This action clears programmable logic configuration, which the PS software can then act on. See the *Zynq UltraScale+ MPSoC Technical Reference Manual* (UG1085) [Ref 3] for information about Zynq UltraScale+ MPSoC configuration.

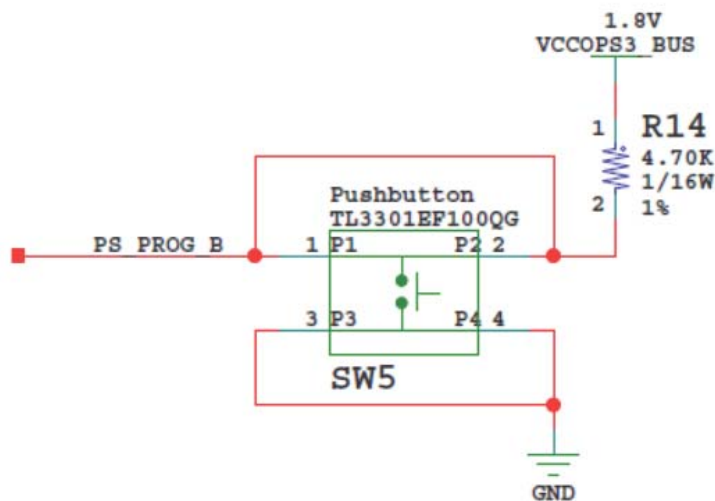

X16549-071817

Figure 3-43: PS_PROG_B Pushbutton Switch SW5

System Reset Pushbuttons

[Figure 2-1, callout 26]

Figure 3-44 shows the reset circuitry for the processing system.

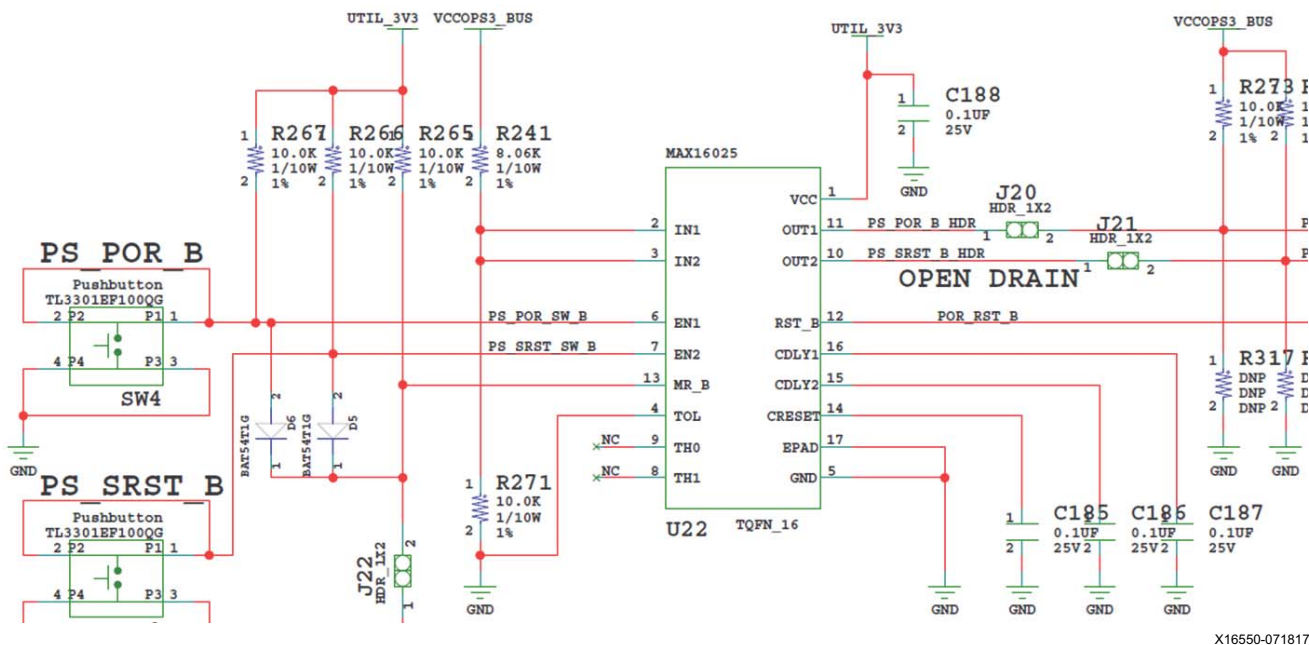

Figure 3-44: PS SRST_B and POR_B Pushbutton Switches SW3 and SW4

PS_POR_B Reset

Depressing and then releasing pushbutton SW4 causes net PS_POR_B to strobe Low. This reset is used to hold the PS in reset until all PS power supplies are at the required voltage levels. It must be held Low through PS power-up. PS_POR_B should be generated by the power supply power-good signal. When the voltage at IN1 is below its threshold or EN1 (P.B. switch SW4 is pressed) goes Low, OUT1 (PS_POR_B) goes Low.

PS_SRST_B Reset

Depressing and then releasing pushbutton SW3 causes net PS_SRST_B to strobe Low. This reset is used to force a system reset. It can be tied or pulled High, and can be High during the PS supply power ramps. When the voltage at IN2 is below its threshold or EN2 (P.B. switch SW3 is pressed) goes Low, OUT2 (PS_SRST_B) goes Low.

Active-Low Reset Output RST_B asserts when any of the monitored voltages (IN_) falls below its respective threshold, any EN_ goes Low, or MR is asserted. RST_B remains asserted for the reset time-out period after all of the monitored voltages exceed their respective threshold, all EN_ are High, all OUT_ are high, and MR is deasserted. See the *Zynq UltraScale+ MPSoC Technical Reference Manual* (UG1085) [Ref 3] for information for information concerning the resets.

ZCU102 Board Power System

[Figure 2-1, callout 34]

The ZCU102 hosts a Maxim PMBus based power system. Each individual Maxim MAX20751EKX, MAX15301, or MAX15303 voltage regulator has a PMBus interface.

Figure 3-45 shows the ZCU102 power system block diagram.

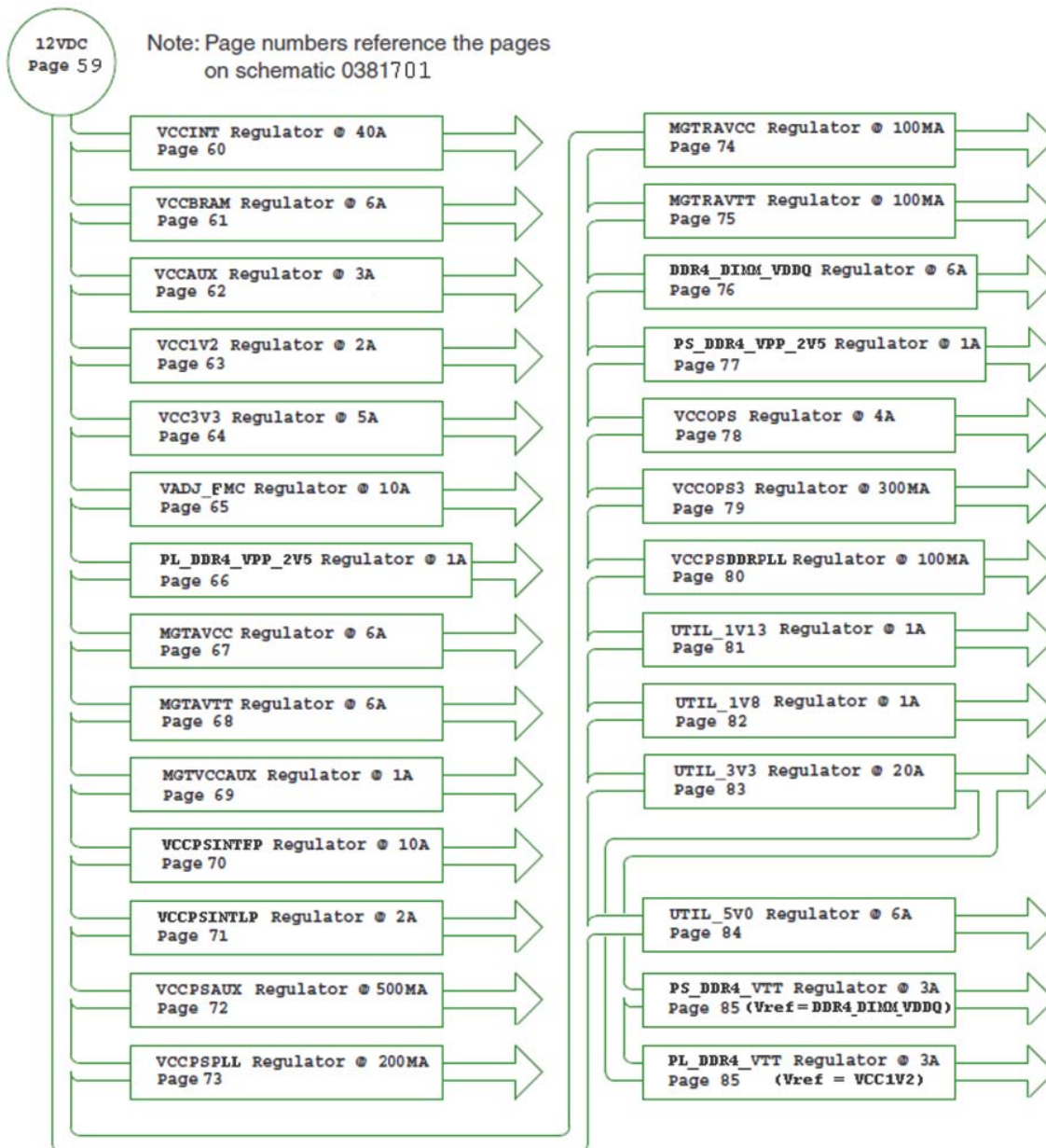

X16551-071817

Figure 3-45: ZCU102 Power System Block Diagram

The ZCU102 evaluation board uses power regulators and PMBus compliant POL controllers from Maxim Integrated Circuits [Ref 28] to supply the core and auxiliary voltages listed in Table 3-55. The schematic page references are to 0381701.

Table 3-55: ZCU102 Power System Devices

Device Type	Ref. Des.	PMBus Address	Description	Power Rail Net Name	Power Rail Voltage	INA226 Address	Schematic Page
MAX15301	U47	0x13	Maxim InTune digital POL controller 40A	VCCINT	0.85V	0x40	60
MAX15303	U7	0x14	Maxim InTune digital POL controller 6A	VCCBRAM	0.85V	0x41	61
MAX15303	U6	0x15	Maxim InTune digital POL controller 3A	VCCAUX	1.80V	0x42	62
MAX15303	U10	0x16	Maxim InTune digital POL controller 2A	VCC1V2	1.20V	0x43	63
MAX15303	U9	0x17	Maxim InTune digital POL controller 5A	VCC3V3	3.30V	0x44	64
MAX15301	U63	0x18	Maxim InTune digital POL controller 10A	VADJ_FMC	1.80V	0x45	65
MAX15027	U38	N/A	Maxim LDO Regulator 1A	PL_DDR4_VPP_2V5	2.5V	N/A	66
MAX20751EKX	U95	0x72	Maxim multiphase master with smart slave VT77518 6A	MGTA VCC	0.90V	0x46	67
MAX20751EKX	U96	0x73	Maxim multiphase master with smart slave VT77518 6A	MGTA VTT	1.20V	0x47	68
MAX8869E	U14	N/A	Maxim LDO Regulator 1A	MGTVCCAUX	1.81V	NA	69
MAX15301	U46	0x0A	Maxim InTune digital POL controller 10A	VCCPSINTFP	0.85V	0x40	70
MAX15303	U4	0x0B	Maxim InTune digital POL controller 2A	VCCPSINTLP	0.85V	0x41	71
MAX8869E	U3	N/A	Maxim LDO Regulator 500 MA	VCCPSAUX	1.81V	0x42	72
MAX8869E	U17	N/A	Maxim LDO Regulator 200 MA	VCCPSPLL	1.20V	0x43	73
MAX8869E	U5	N/A	Maxim LDO Regulator 400 MA	MGTRAVCC	0.85V	0x44	74
MAX8869E	U12	N/A	Maxim LDO Regulator 100 MA	MGTRAVTT	1.81V	0x45	75
MAX15303	U18	0x1D	Maxim InTune digital POL controller 6A	DDR4_DIMM_VDD Q	1.20V	N/A	76
MAX15027	U39	N/A	Maxim LDO Regulator 1A	PS_DDR4_VPP_2V5	2.50V	N/A	77
MAX15303	U13	0x10	Maxim InTune digital POL controller 4A	VCCOPS	1.80V	0x47	78
MAX8869E	U31	N/A	Maxim LDO Regulator 300 MA	VCCOPS3	1.81V	0x4A	79
MAX8869E	U30	N/A	Maxim LDO Regulator 100 MA	VCCPSDDRPLL	1.81V	0x4B	80

Table 3-55: ZCU102 Power System Devices (Cont'd)

Device Type	Ref. Des.	PMBus Address	Description	Power Rail Net Name	Power Rail Voltage	INA226 Address	Schematic Page
MAX8869E	U143	N/A	Maxim LDO Regulator 1A	UTIL_1V13	1.13V	NA	81
MAX8869E	U37	N/A	Maxim LDO Regulator 1A	UTIL_1V8	1.80V	NA	82
MAX15301	U49	0x1A	Maxim InTune digital POL controller 20A	UTIL_3V3	3.30V	NA	83
MAX15303	U8	0x1B	Maxim InTune digital POL controller 6A	UTIL_5V0	5.00V	NA	84
TPS15200	U36	N/A	Memory Vtt Sink-Source Regulator 3A	PS_DDR4_VTT	0.6V	NA	85
TPS15200	U35	N/A	Memory Vtt Sink-Source Regulator 3A	PL_DDR4_VTT	0.6V	NA	85

The FMC HPC0 (J5) and FMC HPC1 (J4) VADJ pins are wired to the programmable rail VADJ_FMC_BUS. The VADJ_FMC_BUS rail is programmed to 1.80V by default. The VADJ_FMC derivative rail powers the XCZU9EG HP banks 64 - 67 (refer to [Table 3-2](#)).

Documentation describing PMBUS programming for the Maxim InTune power controllers is available at the Maxim website [\[Ref 28\]](#). The PCB layout and power system design meets the recommended criteria described in the *UltraScale Architecture PCB Design User Guide* (UG583) [\[Ref 5\]](#).

Monitoring Voltage and Current

Voltage and current monitoring and control are available for the Maxim power system controllers through the Maxim PowerTool graphical user interface. The on-board Maxim InTune power controllers listed in [Table 3-55](#) are accessed through the 2x8 keyed shrouded PMBus connector J84, which is provided for use with the Maxim PowerTool USB cable (Maxim part number MAXPOWERTOOL001#), which can be ordered from the Maxim website [\[Ref 28\]](#). The associated Maxim PowerTool GUI can be downloaded from the Maxim website. This is the simplest and most convenient way to monitor the voltage and current values for the Maxim PMBus programmed power rails listed in [Table 3-55](#).

Each PMBus programmable Maxim controller programmable is capable of reporting the voltage and current of its controlled rail to the Maxim GUI for display to the user. A subset of the programmable rails and two fixed rails have a TI INA226 PMBus power monitor circuit with connections to the rail sense net and taps on a series current sense resistor. This

arrangement permits the INA226 to report the sensed parameters on the PMBus. The subset of rails configured with the INA226 power monitors is shown in [Table 3-56](#).

Table 3-56: ZCU102 Power Rails with INA226 Power Monitors

Device Type	Ref. Des.	PMBus Address	Power Rail Net Name	INA226 Address	Schematic Page
MAX15301	U47	0x13	VCCINT	PL: 0x40	60
MAX15303	U7	0x14	VCCBRAM	PL: 0x41	61
MAX15303	U6	0x15	VCCAUX	PL: 0x42	62
MAX15303	U10	0x16	VCC1V2	PL: 0x43	63
MAX15303	U9	0x17	VCC3V3	PL: 0x44	64
MAX15301	U63	0x18	VADJ_FMC	PL: 0x45	65
MAX20751	U95	0x72	MGTAVCC	PL: 0x46	67
MAX20751	U96	0x73	MGTAVTT	PL: 0x47	68
MAX15301	U46	0x0A	VCCPSINTFP	PS: 0x40	70
MAX15303	U4	0x0B	VCCPSINTLP	PS: 0x41	71
MAX8869E	U3	NA	VCCPSAUX	PS: 0x42	72
MAX8869E	U17	NA	VCCPSPLL	PS: 0x43	73
MAX8869E	U5	NA	MGTRAVCC	PS: 0x44	74
MAX8869E	U12	NA	MGTRAVTT	PS: 0x45	75
MAX15303	U13	0x10	VCCOPS	PS: 0x47	78
MAX8869E	U31	NA	VCCOPS3	PS: 0x4A	79
MAX8869E	U30	NA	VCCPSDDRPLL	PS: 0x4B	80

As noted in the [I2C0 \(MIO 14-15\)](#), the I2C0 bus provides access to the PMBus power controllers and PS-side and PL-side INA226 power monitors via the U60 PCA9544A bus switch. All PMBus controlled Maxim regulators are tied to the MAXIM_PMBUS, while the INA226 power monitors are separated on to PS_PMBUS and PL_PMBUS.

[Figure 3-17](#) and [Table 3-19](#) document the I2C0 bus access path to the Maxim PMBus controllers and INA226 power monitor op amps. Also refer to schematic 0381701.

The MPSoC core related power rail measurements (PL_PMBUS) and PS related power measurements (PS_PMBUS) are accessible to the system controller and PL logic through their respective I2C0 bus connections. These measurements are displayed in the system controller menu selections. The Maxim controller PMBus is also accessible by the system controller, which can also display the rail voltage measurement made by its sourcing Maxim controller. User IP in the PL can access the same set of PMBus resident devices through the logic I2C0 connections.

VITA 57.1 FMC Connector Pinouts

Overview

Figure A-1 shows the pinout of the FPGA mezzanine card (FMC) high pin count (HPC) connector defined by the VITA 57.1 FMC specification. For a description of how the ZCU102 evaluation board implements the FMC specification, see [FPGA Mezzanine Card Interface](#), [FMC HPC0 Connector J5](#), and [FMC HPC1 Connector J4](#).

	K	J	H	G	F	E	D	C	B	A
1	VREF_B M2C	GND	VREF_A M2C	GND	PG M2C	GND	PG C2M	GND	CLK DIR	GND
2	GND	CLK3 BIDIR P	PRSNM M2C L	CLK1 M2C P	GND	HA01 P CC	GND	DP0 C2M P	GND	DP1 M2C P
3	GND	CLK3 BIDIR N	GND	CLK1 M2C N	GND	HA01 N CC	GND	DP0 C2M N	GND	DP1 M2C N
4	CLK2 BIDIR P	GND	CLK0 M2C P	GND	HA00 P CC	GND	GBTCLK0 M2C	GND	DP9 M2C P	GND
5	CLK2 BIDIR N	GND	CLK0 M2C N	GND	HA00 N CC	GND	GBTCLK0 M2C	GND	DP9 M2C N	GND
6	GND	HA03 P	GND	LA00 P CC	GND	HA05 P	GND	DP0 M2C P	GND	DP2 M2C P
7	HA02 P	HA03 N	LA02 P	LA00 N CC	HA04 P	HA05 N	GND	DP0 M2C N	GND	DP2 M2C N
8	HA02 N	GND	LA02 N	GND	HA04 N	GND	LA01 P CC	GND	DP8 M2C P	GND
9	GND	HA07 P	GND	LA03 P	GND	HA09 P	LA01 N CC	GND	DP8 M2C N	GND
10	HA06 P	HA07 N	LA04 P	LA03 N	HA08 P	HA09 N	GND	LA06 P	GND	DP3 M2C P
11	HA06 N	GND	LA04 N	GND	HA08 N	GND	LA05 P	LA06 N	GND	DP3 M2C N
12	GND	HA11 P	GND	LA08 P	GND	HA13 P	LA05 N	GND	DP7 M2C P	GND
13	HA10 P	HA11 N	LA07 P	LA08 N	HA12 P	HA13 N	GND	GND	DP7 M2C N	GND
14	HA10 N	GND	LA07 N	GND	HA12 N	GND	LA09 P	LA10 P	GND	DP4 M2C P
15	GND	HA14 P	GND	LA12 P	GND	HA16 P	LA09 N	LA10 N	GND	DP4 M2C N
16	HA17 P CC	HA14 N	LA11 P	LA12 N	HA15 P	HA16 N	GND	GND	DP6 M2C P	GND
17	HA17 N CC	GND	LA11 N	GND	HA15 N	GND	LA13 P	GND	DP6 M2C N	GND
18	GND	HA18 P	GND	LA16 P	GND	HA20 P	LA13 N	LA14 P	GND	DP5 M2C P
19	HA21 P	HA18 N	LA15 P	LA16 N	HA19 P	HA20 N	GND	LA14 N	GND	DP5 M2C N
20	HA21 N	GND	LA15 N	GND	HA19 N	GND	LA17 P CC	GND	GBTCLK1 M2C	GND
21	GND	HA22 P	GND	LA20 P	GND	HB03 P	LA17 N CC	GND	GBTCLK1 M2C	GND
22	HA23 P	HA22 N	LA19 P	LA20 N	HB02 P	HB03 N	GND	LA18 P CC	GND	DP1 C2M P
23	HA23 N	GND	LA19 N	GND	HB02 N	GND	LA23 P	LA18 N CC	GND	DP1 C2M N
24	GND	HB01 P	GND	LA22 P	GND	HB05 P	LA23 N	GND	DP9 C2M P	GND
25	HB00 P CC	HB01 N	LA21 P	LA22 N	HB04 P	HB05 N	GND	GND	DP9 C2M N	GND
26	HB00 N CC	GND	LA21 N	GND	HB04 N	GND	LA26 P	LA27 P	GND	DP2 C2M P
27	GND	HB07 P	GND	LA25 P	GND	HB09 P	LA26 N	LA27 N	GND	DP2 C2M N
28	HB06 P CC	HB07 N	LA24 P	LA25 N	HB08 P	HB09 N	GND	GND	DP8 C2M P	GND
29	HB06 N CC	GND	LA24 N	GND	HB08 N	GND	TCK	GND	DP8 C2M N	GND
30	GND	HB11 P	GND	LA29 P	GND	HB13 P	TDI	SCL	GND	DP3 C2M P
31	HB10 P	HB11 N	LA28 P	LA29 N	HB12 P	HB13 N	TDO	SDA	GND	DP3 C2M N
32	HB10 N	GND	LA28 N	GND	HB12 N	GND	3P3VAUX	GND	DP7 C2M P	GND
33	GND	HB15 P	GND	LA31 P	GND	HB19 P	TMS	GND	DP7 C2M N	GND
34	HB14 P	HB15 N	LA30 P	LA31 N	HB16 P	HB19 N	TRST_L	GA0	GND	DP4 C2M P
35	HB14 N	GND	LA30 N	GND	HB16 N	GND	GA1	12P0V	GND	DP4 C2M N
36	GND	HB18 P	GND	LA33 P	GND	HB21 P	3P3V	GND	DP6 C2M P	GND
37	HB17 P CC	HB18 N	LA32 P	LA33 N	HB20 P	HB21 N	GND	12P0V	DP6 C2M N	GND
38	HB17 N CC	GND	LA32 N	GND	HB20 N	GND	3P3V	GND	GND	DP5 C2M P
39	GND	VIO_B M2C	GND	VADJ	GND	VADJ	GND	3P3V	GND	DP5 C2M N
40	VIO_B M2C	GND	VADJ	GND	VADJ	GND	3P3V	GND	RES0	GND

X22901-051519

Figure A-1: FMC HPC Connector Pinout

Xilinx Design Constraints

Overview

The Xilinx design constraints (XDC) file template for the ZCU102 board provides for designs targeting the ZCU102 evaluation board. Net names in the constraints correlate with net names on the latest ZCU102 evaluation board schematic. Identify the appropriate pins and replace the net names with net names in the user RTL. See the *Vivado Design Suite User Guide: Using Constraints* (UG903) [Ref 12] for more information.

The FMC connectors J5 (HPC0) and J4 (HPC1) are connected to MPSoC banks powered by the variable voltage V_{AJ_FMC} . Because different FMC cards implement different circuitry, the FMC bank I/O standards must be uniquely defined by each customer.



IMPORTANT: *The XDC file can be accessed on the [Zynq UltraScale+ MPSoC ZCU102 Evaluation Kit website](#).*

Regulatory and Compliance Information

Overview

This product is designed and tested to conform to the European Union directives and standards described in this section.

[ZCU102 Evaluation Kit Master Answer Record 66752](#)

For Technical Support, open a [Support Service Request](#).

CE Directives

2006/95/EC, *Low Voltage Directive (LVD)*

2004/108/EC, *Electromagnetic Compatibility (EMC) Directive*

CE Standards

EN standards are maintained by the European Committee for Electrotechnical Standardization (CENELEC). IEC standards are maintained by the International Electrotechnical Commission (IEC).

Electromagnetic Compatibility

EN 55022:2010, *Information Technology Equipment Radio Disturbance Characteristics – Limits and Methods of Measurement*

EN 55024:2010, *Information Technology Equipment Immunity Characteristics – Limits and Methods of Measurement*

This is a Class A product. In a domestic environment, this product can cause radio interference, in which case the user might be required to take adequate measures.

Safety

IEC 60950-1:2005, *Information technology equipment – Safety, Part 1: General requirements*

EN 60950-1:2006, *Information technology equipment – Safety, Part 1: General requirements*

Markings



In August of 2005, the European Union (EU) implemented the EU WEEE Directive 2002/96/EC and later the WEEE Recast Directive 2012/19/EU requiring Producers of electronic and electrical equipment (EEE) to manage and finance the collection, reuse, recycling and to appropriately treat WEEE that the Producer places on the EU market after August 13, 2005. The goal of this directive is to minimize the volume of electrical and electronic waste disposal and to encourage re-use and recycling at the end of life.

Xilinx has met its national obligations to the EU WEEE Directive by registering in those countries to which Xilinx is an importer. Xilinx has also elected to join WEEE Compliance Schemes in some countries to help manage customer returns at end-of-life.

If you have purchased Xilinx-branded electrical or electronic products in the EU and are intending to discard these products at the end of their useful life, please do not dispose of them with your other household or municipal waste. Xilinx has labeled its branded electronic products with the WEEE Symbol to alert our customers that products bearing this label should not be disposed of in a landfill or with municipal or household waste in the EU.

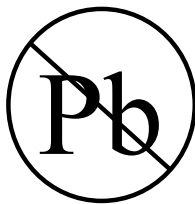

This product complies with Directive 2002/95/EC on the restriction of hazardous substances (RoHS) in electrical and electronic equipment.



This product complies with CE Directives 2006/95/EC, *Low Voltage Directive (LVD)* and 2004/108/EC, *Electromagnetic Compatibility (EMC) Directive*.

Additional Resources and Legal Notices

Xilinx Resources

For support resources such as Answers, Documentation, Downloads, and Forums, see [Xilinx Support](#).

Solution Centers

See the [Xilinx Solution Centers](#) for support on devices, software tools, and intellectual property at all stages of the design cycle. Topics include design assistance, advisories, and troubleshooting tips.

Documentation Navigator and Design Hubs

Xilinx® Documentation Navigator provides access to Xilinx documents, videos, and support resources, which you can filter and search to find information. To open the Xilinx Documentation Navigator (DocNav):

- From the Vivado® IDE, select **Help > Documentation and Tutorials**.
- On Windows, select **Start > All Programs > Xilinx Design Tools > DocNav**.
- At the Linux command prompt, enter `docnav`.

Xilinx Design Hubs provide links to documentation organized by design tasks and other topics, which you can use to learn key concepts and address frequently asked questions. To access the Design Hubs:

- In the Xilinx Documentation Navigator, click the **Design Hubs View** tab.
- On the Xilinx website, see the [Design Hubs](#) page.

Note: For more information on Documentation Navigator, see the [Documentation Navigator](#) page on the Xilinx website.

References

The most up to date information related to the ZCU102 board and its documentation is available on the following websites.

[ZCU102 Evaluation Kit](#)

[ZCU102 Evaluation Kit Master Answer Record 66752](#)

These Xilinx documents provide supplemental material useful with this guide:

1. *Zynq UltraScale+ MPSoC Data Sheet: Overview* ([DS891](#))
2. *Zynq UltraScale+ MPSoC Data Sheet: DC and AC Switching Characteristics* ([DS925](#))
3. *Zynq UltraScale+ MPSoC Technical Reference Manual* ([UG1085](#))
4. [Xilinx HDMI IP documentation](#)
5. *UltraScale Architecture PCB Design User Guide* ([UG583](#))
6. *UltraScale Architecture FPGAs Memory Interface Solutions LogiCORE IP Product Guide* ([PG150](#))
7. *UltraScale Architecture GTH Transceivers User Guide* ([UG576](#))
8. *UltraScale Architecture Gen3 Integrated Block for PCI Express LogiCORE IP Product Guide* ([PG156](#))
9. *UltraScale Architecture SelectIO Resources User Guide* ([UG571](#))
10. *Silicon Labs CP210x USB-to-UART Installation Guide* ([UG1033](#))
11. *Tera Term Terminal Emulator Installation Guide* ([UG1036](#))
12. *Vivado Design Suite User Guide: Using Constraints User Guide* ([UG903](#))
13. *HDMI 1.4/2.0 Transmitter Subsystem LogiCORE IP Product Guide* ([PG235](#))
14. [HDMI Transmitter and Receiver Subsystem Answer Record 70514](#)
15. *HDMI 1.4/2.0 Receiver Subsystem LogiCORE IP Product Guide* ([PG236](#))
16. *UltraScale Architecture System Monitor User Guide* ([UG580](#))
17. *ZCU102 System Controller Tutorial* ([XTP433](#))
18. *ZCU102 Software Install and Board Setup Tutorial* ([XTP435](#))
19. [Zynq UltraScale+ MPSoC ZCU102 Evaluation Kit Design Hub](#)

The following websites provide supplemental material useful with this guide:

20. Micron Technology: www.micron.com
(MTA4ATF51264HZ-2G6E1, MT41J256M8HX-15E, MT25QU512ABB8ESF-0SIT data sheets)
21. Standard Microsystems Corporation (SMSC):
www.microchip.com/redirect-notifications/smsc
(USB3320 data sheet)
22. SanDisk Corporation: www.sandisk.com/
23. SD Association: www.sdcard.org/
24. Silicon Labs: www.silabs.com/Pages/default.aspx
(SI5341B-B05071, Si570BAB001614DG Si570BAB0000544DG, Si570, Si53340, CP2108 data sheets)
25. Texas Instruments <http://www.ti.com/product/DP83867IR>
(TI DP83867 data sheet)
26. PCI website: <https://pcisig.com/specifications>
27. Pericom PI2DBS6212: <https://www.pericom.com/assets/Datasheets/PI2DBS6212.pdf>
28. Maxim Integrated Circuits: <https://www.maximintegrated.com>
29. VITA FMC Marketing Alliance website: <http://www.vita.com/fmc>
30. Digilent: www.digilentinc.com (USB JTAG Module, Pmod peripheral modules)

Please Read: Important Legal Notices

The information disclosed to you hereunder (the "Materials") is provided solely for the selection and use of Xilinx products. To the maximum extent permitted by applicable law: (1) Materials are made available "AS IS" and with all faults, Xilinx hereby DISCLAIMS ALL WARRANTIES AND CONDITIONS, EXPRESS, IMPLIED, OR STATUTORY, INCLUDING BUT NOT LIMITED TO WARRANTIES OF MERCHANTABILITY, NON-INFRINGEMENT, OR FITNESS FOR ANY PARTICULAR PURPOSE; and (2) Xilinx shall not be liable (whether in contract or tort, including negligence, or under any other theory of liability) for any loss or damage of any kind or nature related to, arising under, or in connection with, the Materials (including your use of the Materials), including for any direct, indirect, special, incidental, or consequential loss or damage (including loss of data, profits, goodwill, or any type of loss or damage suffered as a result of any action brought by a third party) even if such damage or loss was reasonably foreseeable or Xilinx had been advised of the possibility of the same. Xilinx assumes no obligation to correct any errors contained in the Materials or to notify you of updates to the Materials or to product specifications. You may not reproduce, modify, distribute, or publicly display the Materials without prior written consent. Certain products are subject to the terms and conditions of Xilinx's limited warranty, please refer to Xilinx's Terms of Sale which can be viewed at <https://www.xilinx.com/legal.htm#tos>; IP cores may be subject to warranty and support terms contained in a license issued to you by Xilinx. Xilinx products are not designed or intended to be fail-safe or for use in any application requiring fail-safe performance; you assume sole risk and liability for use of Xilinx products in such critical applications, please refer to Xilinx's Terms of Sale which can be viewed at <https://www.xilinx.com/legal.htm#tos>.

AUTOMOTIVE APPLICATIONS DISCLAIMER

AUTOMOTIVE PRODUCTS (IDENTIFIED AS "XA" IN THE PART NUMBER) ARE NOT WARRANTED FOR USE IN THE DEPLOYMENT OF AIRBAGS OR FOR USE IN APPLICATIONS THAT AFFECT CONTROL OF A VEHICLE ("SAFETY APPLICATION") UNLESS THERE IS A SAFETY CONCEPT OR REDUNDANCY FEATURE CONSISTENT WITH THE ISO 26262 AUTOMOTIVE SAFETY STANDARD ("SAFETY DESIGN"). CUSTOMER SHALL, PRIOR TO USING OR DISTRIBUTING ANY SYSTEMS THAT INCORPORATE PRODUCTS, THOROUGHLY TEST SUCH SYSTEMS FOR SAFETY PURPOSES. USE OF PRODUCTS IN A SAFETY APPLICATION WITHOUT A SAFETY DESIGN IS FULLY AT THE RISK OF CUSTOMER, SUBJECT ONLY TO APPLICABLE LAWS AND REGULATIONS GOVERNING LIMITATIONS ON PRODUCT LIABILITY.

© Copyright 2016–2019 Xilinx, Inc. Xilinx, the Xilinx logo, Artix, ISE, Kintex, Spartan, Virtex, Vivado, Zynq, and other designated brands included herein are trademarks of Xilinx in the United States and other countries. PCI, PCIe, and PCI Express are trademarks

of PCI-SIG and used under license. The DisplayPort Icon is a trademark of the Video Electronics Standards Association, registered in the U.S. and other countries. AMBA, AMBA Designer, Arm, ARM1176JZ-S, CoreSight, Cortex, PrimeCell, Mali, and MPCore are trademarks of Arm Limited in the EU and other countries. HDMI, HDMI logo, and High-Definition Multimedia Interface are trademarks of HDMI Licensing LLC. All other trademarks are the property of their respective owners.



**Стандарт
Электрон
Связь**

Мы молодая и активно развивающаяся компания в области поставок электронных компонентов. Мы поставляем электронные компоненты отечественного и импортного производства напрямую от производителей и с крупнейших складов мира.

Благодаря сотрудничеству с мировыми поставщиками мы осуществляем комплексные и плановые поставки широчайшего спектра электронных компонентов.

Собственная эффективная логистика и склад в обеспечивает надежную поставку продукции в точно указанные сроки по всей России.

Мы осуществляем техническую поддержку нашим клиентам и предпродажную проверку качества продукции. На все поставляемые продукты мы предоставляем гарантию .

Осуществляем поставки продукции под контролем ВП МО РФ на предприятия военно-промышленного комплекса России , а также работаем в рамках 275 ФЗ с открытием отдельных счетов в уполномоченном банке. Система менеджмента качества компании соответствует требованиям ГОСТ ISO 9001.

Минимальные сроки поставки, гибкие цены, неограниченный ассортимент и индивидуальный подход к клиентам являются основой для выстраивания долгосрочного и эффективного сотрудничества с предприятиями радиоэлектронной промышленности, предприятиями ВПК и научно-исследовательскими институтами России.

С нами вы становитесь еще успешнее!

Наши контакты:

Телефон: +7 812 627 14 35

Электронная почта: sales@st-electron.ru

Адрес: 198099, Санкт-Петербург,
Промышленная ул, дом № 19, литера Н,
помещение 100-Н Офис 331