

Circuits from the Lab™ Reference Circuits

Circuits from the Lab™ reference circuits are engineered and tested for quick and easy system integration to help solve today's analog, mixed-signal, and RF design challenges. For more information and/or support, visit www.analog.com/CN0204.

Devices Connected/Referenced

AD5751	High Voltage Industrial Current/Voltage Output Driver with Programmable Ranges
AD5662	16-Bit nanoDAC® Digital-to-Analog Converter in SOT-23
ADR444	Ultralow Noise, 4.096V LDO XFET Voltage Reference with Current Sink and Source
ADuM5401	Quad-Channel Isolator with Integrated DC-to-DC Converter
ADuM1301	Triple-Channel Digital Isolator

Flexible, High Voltage, High Accuracy, Low Drift PLC/DCS Analog Output Module

EVALUATION AND DESIGN SUPPORT

Circuit Evaluation Boards

[CN-0204 Circuit Evaluation Board \(EVAL-CN0204-SDPZ\)](#)

[System Demonstration Platform \(EVAL-SDP-CB1Z\)](#)

Design and Integration Files

[Schematics, Layout Files, Bill of Materials](#)

CIRCUIT FUNCTION AND BENEFITS

The circuit, shown in Figure 1, provides a full function, high voltage (up to 44 V), flexible, programmable analog output solution that meets most requirements for programmable logic controller (PLC) and distributed control system (DCS) applications.

The [AD5662](#) low power (0.75 mW typical @ 5 V), rail-to-rail output, 16-bit nanoDAC® device and the [AD5751](#) industrial current/voltage output driver are well matched with respect to input and output voltage ranges, as well as reference voltage requirements.

The [ADR444](#), with low drift (3 ppm/°C maximum for B grade), high initial accuracy (0.04% maximum for B grade), and low noise (1.8 μ V p-p typical, 0.1 Hz to 10 Hz), provides the reference voltage for both the [AD5751](#) and [AD5662](#) and guarantees ultralow noise, high accuracy, and low temperature drift for the circuit. This circuit provides all the typical voltage

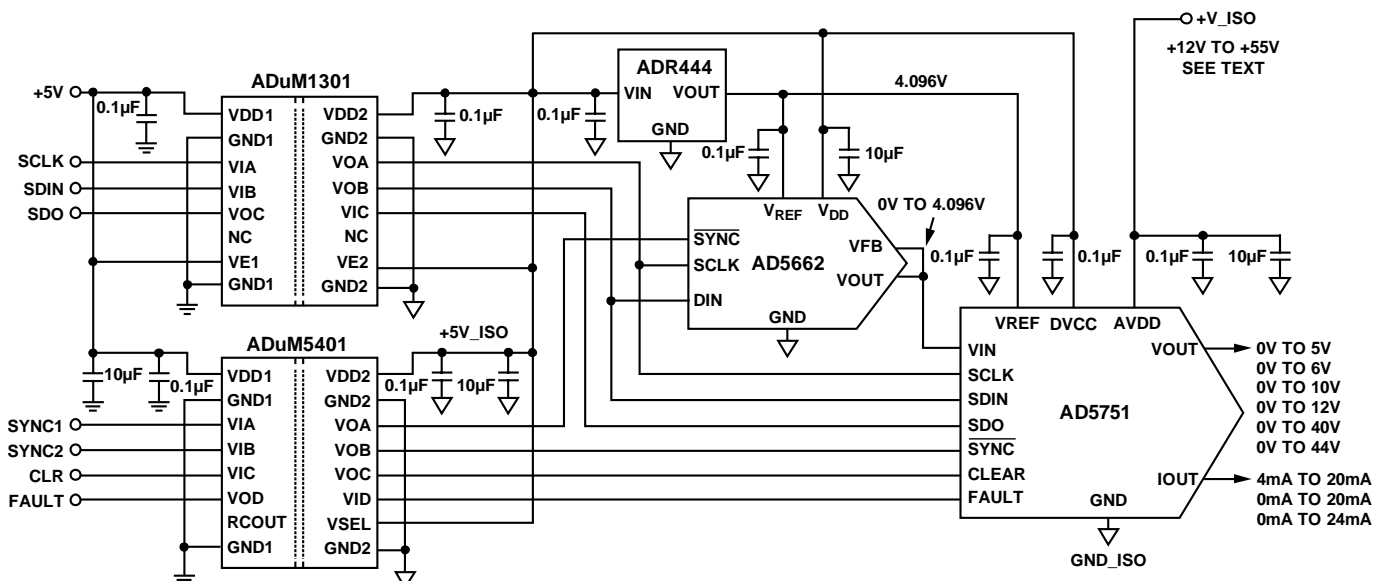

Figure 1. Basic Analog Output Circuit for Single Channel (Simplified Schematic, All Connections and Protection Circuits Not Shown)

Rev.0

Circuits from the Lab™ circuits from Analog Devices have been designed and built by Analog Devices engineers. Standard engineering practices have been employed in the design and construction of each circuit, and their function and performance have been tested and verified in a lab environment at room temperature. However, you are solely responsible for testing the circuit and determining its suitability and applicability for your use and application. Accordingly, in no event shall Analog Devices be liable for direct, indirect, special, incidental, consequential or punitive damages due to any cause whatsoever connected to the use of any Circuits from the Lab circuits. (Continued on last page)

and current output ranges with 16-bit resolution and no missing codes, 0.05% linearity, and less than 0.2% total output error.

The [ADuM1301](#) and [ADuM5401](#) provide all the necessary signal isolation between the microcontroller and the analog signal chain. The [ADuM5401](#) also provides isolated 5 V power.

The circuit also contains key features for industrial applications, such as on-chip output fault detection, CRC checking to prevent packet error (PEC), and flexible power-up options, making it an ideal choice for robust industrial control systems. No external precision resistors or calibration routines are needed to maintain consistent performance in mass production, thereby making it ideal for PLC or DCS modules.

CIRCUIT DESCRIPTION

The [AD5751](#) is a single channel, low cost, precision voltage/current output driver developed to meet the requirements of industrial process control applications. The [AD5751](#) is specified to operate with a power supply range from 10.8 V to 55 V, and the voltage output can be up to 44 V. The voltage output range can be programmed for the standard output ranges and 20% overrange settings for PLC and DCS applications: 0 V to 5 V, 0 V to 10 V, 0 V to 6 V, 0 V to 12 V. In addition, two high voltage output ranges are also provided: 0 V to 40 V and 0 V to 44 V.

The current output, which is provided on a separate pin, can be programmed for the standard ranges of 4 mA to 20 mA, 0 mA to 20 mA, 0 mA to 24 mA. There is also a 2% overrange setting which provides 3.92 mA to 20.4 mA, 0 mA to 20.4 mA, and 0 mA to 24.5 mA. The voltage and current output pins can be tied together to configure the end system as a single-channel output if desired.

The [AD5662](#) is a single channel, low cost, low power, rail-to-rail voltage buffered output *nano*DAC device. The [AD5662](#) guarantees ± 1 LSB DNL under a wide range of reference voltages that can vary from 0.75 V to the V_{DD} supply. In the circuit of Figure 1, the [AD5751](#) and [AD5662](#) operate from a common reference source of 4.096 V, provided by the [ADR444](#). The whole system will benefit from the ultralow noise and low temperature coefficient of the [ADR444](#). The [ADR44x](#) family of references are ideal for driving either the reference or the power input of converters because they can source and sink current. The [AD5662](#) also incorporates a power-on reset circuit to ensure that the DAC output powers up to either midscale or zero and remains there until a valid write takes place.

The [ADuM1301](#) is a triple channel digital isolator. The [ADuM5401](#) is a quad channel digital isolator with *isoPower*[®] integrated, isolated, dc-to-dc converter. They are both based on the *iCoupler*[®] technology. They are used to provide isolation between the signal chain and the system microcontroller, with an isolation rating of 2.5 kV rms. The [ADuM5401](#) provides an isolated 5 V power supply for all the circuit in the secondary side.

The digital power and analog power should be separated and connected with a ferrite bead. Each power is well decoupled by a 10 μ F paralleled with a 0.1 μ F ceramic capacitor. See the schematics in the [CN0204 Design Support package](#) for more details.

Devices for PLC and DCS applications generally need ESD protection and overvoltage protection much higher than the formal recommended specifications. The [AD5751](#) has integrated ESD protection diodes internal to each pin that can prevent damage from transients. However, the industrial control environment can subject I/O circuits to much higher transients. External 64 V, 1500 W transient voltage suppressors (TVS); a 50 mA, 30 V PolySwitch; and power Schottky diodes are built into the [EVAL-CN0204-SDPZ](#) circuit board to provide higher voltage ESD protection, 50 mA overcurrent, and 64 V overvoltage protection. The optional external protection circuits are not shown in the simplified schematic of Figure 1 but can be found in the detailed schematic ([EVAL-CN0204-SDPZ-SCH](#) pdf file) in the [CN0204 Design Support package](#): www.analog.com/CN0204-DesignSupport.

The circuit must be constructed on a multilayer PC board with a large area ground plane. Proper layout, grounding, and decoupling techniques must be used to achieve optimum performance (see [Tutorial MT-031, Grounding Data Converters and Solving the Mystery of "AGND" and "DGND,"](#) and [Tutorial MT-101, Decoupling Techniques](#)).

Measurements

Integral nonlinearity (INL), differential nonlinearity (DNL), and output error are the most important specifications for PLC, DCS, and other process control systems. The [AD5751](#) has highly flexible and configurable output ranges that can be tailored to meet the needs of the application. Measurements of INL, DNL, and output error for the circuit are shown in Figure 2, Figure 3, and Figure 4, respectively. This data was taken at 25°C in the voltage output mode using the internal current sense resistor. The [AD5751](#) range was set for 0 V to 5 V. The test results for all the other ranges are listed in Table 1.

The test results shown in Table 1 were made at 25°C using the [EVAL-CN0204-SDPZ](#) board powered by an Agilent E3631A dc supply and measured with an Agilent 34401A digital multi-meter.

Note that the output ranges 0 mA to 20.4 mA and 0 mA to 24.5 mA are both designed to be trimmed by the customer to precisely match the 0 mA to 20 mA and 0 mA to 24 mA ranges. The 1.70% FSR output error measurement in the 0 mA to 20.4 mA range includes the gain error, which can be removed by customer calibration.

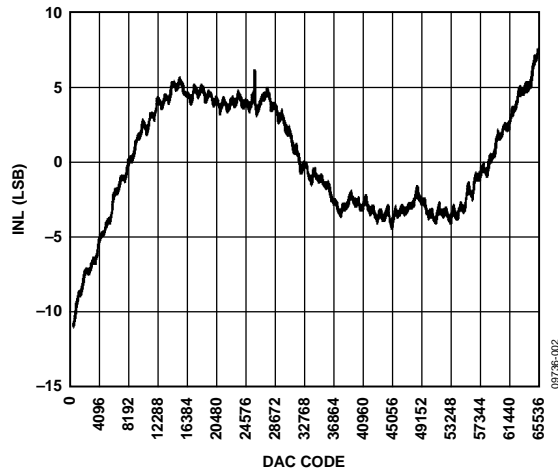

Figure 2. INL for 0V to 5V Output Range

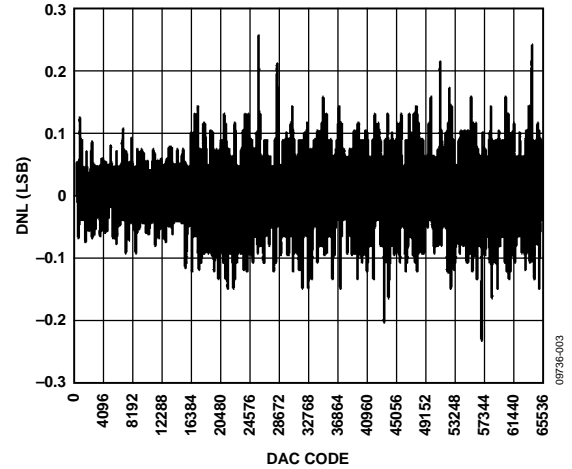

Figure 3. DNL for 0V to 5V Output Range

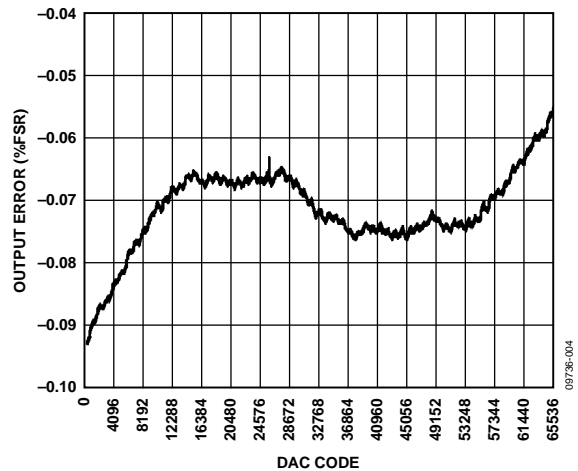

Figure 4. Output Error for 0V to 5V Output Range

Table 1. Test Results for All Output Ranges

Range	Current Sense Resistor	INL (LSB)	Linearity (%FSR)	Output Error (%FSR)
0 V to 5 V	Don't Care	10.8	0.017	0.09
0 V to 10 V	Don't Care	9.9	0.015	0.08
0 V to 6 V	Don't Care	10.5	0.016	0.09
0 V to 12 V	Don't Care	9.2	0.014	0.08
0 V to 40 V	Don't Care	10.1	0.015	0.06
0 V to 44 V	Don't Care	9.5	0.015	0.20
4 mA to 20 mA	Internal	8.5	0.016	0.04
4 mA to 20 mA	External	8.4	0.013	0.04
0 mA to 20 mA	Internal	9.8	0.015	0.05
0 mA to 20 mA	External	8.9	0.014	0.05
0 mA to 24 mA	Internal	8.4	0.013	0.05
0 mA to 24 mA	External	12.0	0.018	0.05
3.92 mA to 20.4 mA	Internal	11.8	0.053	0.80
0 mA to 20.4 mA	Internal	9.4	0.014	1.70
0 mA to 24.5 mA	Internal	12.4	0.019	1.50

COMMON VARIATIONS

This circuit describes one implementation of a family of driver and DAC products, from which various devices can be selected to achieve desired performance. Resolution of 12 bits to 16 bits with 0.1% accuracy are typical requirements for PLC and DCS applications. For applications not requiring 16-bit resolution, the [AD5620](#) (12-bit) and [AD5640](#) (14-bit) are available, and have internal references.

For multichannel applications, the [AD5623R](#) (12-bit), [AD5643R](#) (14-bit), and [AD5663R](#) (16-bit) are dual *nanoDAC* devices, and the [AD5624R](#) (12-bit), [AD5644R](#) (14-bit), and [AD5664R](#) (16-bit) are quad *nanoDAC* devices.

The [AD5750-1](#) and [AD5750](#) are both bipolar analog output drivers and can supply ± 10 V and ± 20 mA.

CIRCUIT EVALUATION AND TEST

Equipment Needed (Equivalents Can Be Substituted)

- System Demonstration Platform ([EVAL-SDP-CB1Z](#))
- CN-0204 Circuit Evaluation Board ([EVAL-CN0204-SDPZ](#))
- CN-0204 Evaluation Software
- Software for controlling external test measurement equipment (not included on CD)
- Agilent 34401A, 6.5 Digit Digital Multimeter
- Agilent E3631A 0 V to 6 V/5 A; ± 25 V/1 A triple output dc power supply
- PC (Windows® 2000 or Windows XP) with USB interface
- National Instruments GPIB to USB-B interface and cable

Getting Started

Load the evaluation software by placing the CN0204 Evaluation Software disc in the CD drive of the PC. Using "My Computer," locate the drive that contains the evaluation software disc and open the Readme file. Follow the instructions contained in the Readme file for installing and using the evaluation software.

Functional Block Diagram

Figure 5 shows a functional block diagram of the test setup. The pdf file "EVAL-CN0204-SDPZ-SCH" contains the detailed circuit schematics for the CN0204 evaluation board. This file is contained in the CN-0204 Design Support Package:

www.analog.com/CN0204-DesignSupport.

Setup

Connect the 120-pin connector on the [EVAL-CN0204-SDPZ](#) circuit board to the connector marked "CON A" or "CON B" on the [EVAL-SDP-CB1Z](#) evaluation (SDP) board. Nylon hardware should be used to firmly secure the two boards, using the holes provided at the ends of the 120-pin connectors. After setting the dc output supply to $+25$ V, -25 V and $+6$ V output, turn the power supply off.

The Agilent E3631A supply has ± 25 V/1 A and 6 V/5 A output channels. The ± 25 V/1 A and 6 V/5 A are isolated with respect to each other. Therefore, the ± 25 V/1 A can be used to provide the $+50$ V power supply to the circuit. There must be no external connection between the "-" terminal of the 6 V/5 A supply and the "COM" terminal of the ± 25 V/1 A supply.

With power to the supply off, connect a $+25$ V power supply to the pin of CN3 marked "12~50VIN," and the -25 V power supply to the pin of CN3 marked "GND_ISO." Leave the "COM" of

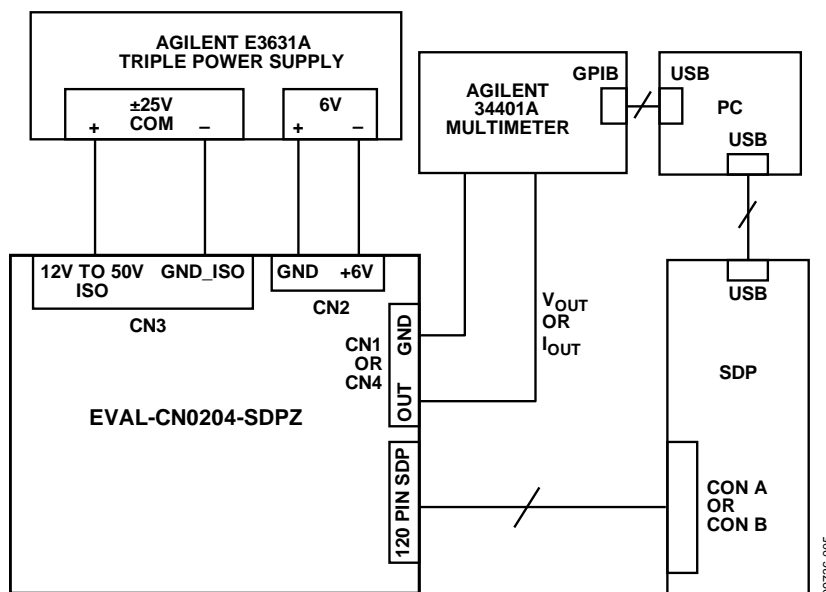

Figure 5. Test Setup Functional Block Diagram

Table 2. Jumper Settings for [EVAL-CN0204-SDPZ](#) (Bold Values Are Default Settings)

Jumper	Descriptions	Setting	Function
JP1	Sets the address of AD5751	Shorting Pin1 with Pin2	Address of AD5751 : b'001
		Shorting Pin3 with Pin2	Address of AD5751 : b'000
JP2	Sets the external compensation capacitor	Shorting	Adding 1 nF Compensation Capacitor
		Opening	Removing 1 nF Compensation Capacitor
JP3	VSENSE+ Setting	Shorting	Shorting VSENSE+ with VOUT internally
		Opening	VSENSE+ has no connection with VOUT internally
JP4	Sets the CLEAR Mode for AD5751	Shorting	Clears to midscale
		Opening	Clears to zero scale
JP5	Shorts the VOUT and IOUT pins	Shorting	Shorts VOUT and IOUT together.
		Opening	VOUT and IOUT have no connection internally

± 25 V/1 A unconnected. Connect +6 V to CN2 the same way. Turn on the power supply and then connect the USB cable with the SDP board to the USB port on the PC. Note: Do not connect the USB cable to the mini USB connector on the SDP board before turning on the dc power supply for the [EVAL-CN0204-SDPZ](#).

Test

After setting up the test equipment, connect the pin of CN4 marked "VOUT" or the pin of CN1 marked "IOUT" to the input of the Agilent 34401A. Make sure that the cable connection on the front panel of the Agilent 34401A is correct, depending on the different input signal type (current or voltage). Testing the INL, DNL, and total error will take a considerable amount of time because all of the [AD5662](#) 16-bit DAC levels must be set and measured by the 34401A.

The software provided on the CD allows the DAC codes to be set by the PC. An automatic test program is necessary to step through the codes and analyze the data. This is not provided on the CD but must be implemented by the customer to correspond to the requirements of the particular multimeter used in the test setup.

In the test configuration shown in Figure 5, the GPIB output of the 34401A multimeter interfaces to a second USB port on the PC using the National Instruments GPIB to USB-B interface and cable. This allows the multimeter readings corresponding to each code to be loaded into an Excel spreadsheet on the PC. The data is then analyzed for INL, DNL, and total error using industry-standard definitions.

For more details on the definitions and how to calculate the INL, DNL, and total error from the measured data, see the "TERMINOLOGY" section of the [AD5662 data sheet](#) and also the following reference: [Data Conversion Handbook](#), "Testing Data Converters," Chapter 5, Analog Devices.

LEARN MORE

CN-0204 Design Support Package:

www.analog.com/CN0204-DesignSupport

Slattery, Colm, Derrick Hartmann, and Li Ke, "PLC Evaluation Board Simplifies Design of Industrial Process Control Systems." *Analog Dialogue* (April 2009).

CN-0063 Circuit Note, *16-Bit Fully Isolated Voltage Output Module Using the AD5662 DAC, ADuM1401 Digital Isolator, and External Amplifiers*, Analog Devices.

CN-0064 Circuit Note, *16-Bit Fully Isolated 4 mA to 20 mA Output Module Using the AD5662 DAC, ADuM1401 Digital Isolator, and External Amplifiers*, Analog Devices.

CN-0065 Circuit Note, *16-Bit Fully Isolated Output Module Using the AD5422 Single Chip Voltage and Current Output DAC and the ADuM1401 Digital Isolator*, Analog Devices.

CN-0066 Circuit Note, *Fully Isolated Input Module Based on the AD7793 24-Bit Σ - Δ ADC and the ADuM5401 Digital Isolator*, Analog Devices.

CN-0067 Circuit Note, *Fully Isolated Input Module Based on the AD7793 24-Bit Σ - Δ ADC, the ADuM5401 Digital Isolator, and a High Performance In-Amp*, Analog Devices.

CN-0097 Circuit Note, *Simplified 12-Bit Voltage and 4 mA-to-20 mA Output Solution Using the AD5412*, Analog Devices.

CN-0209 Circuit Note, *Fully Programmable Universal Analog Front End for Process Control Applications*, Analog Devices.

AN-0971 Application Note, *Recommendations for Control of Radiated Emissions with isoPower Devices*, Mark Cantrell.

MT-031 Tutorial, *Grounding Data Converters and Solving the Mystery of "AGND" and "DGND"*, Analog Devices.

MT-101 Tutorial, *Decoupling Techniques*, Analog Devices.

Kester, Walt. *Practical Design Techniques for Sensor Signal Conditioning*, Analog Devices, 1999, ISBN 0-916550-20-6

Kester, Walt. *Data Conversion Handbook*, Chapter 5, Analog Devices.

Data Sheets and Evaluation Boards

[CN-0204 Circuit Evaluation Board \(EVAL-CN0204-SDPZ\)](#)

[System Demonstration Platform \(EVAL-SDP-CB1Z\)](#)

[AD5751 Data Sheet](#)

[AD5751 Evaluation Board](#)

[AD5662 Data Sheet](#)

[AD5662 Evaluation Board](#)

REVISION HISTORY

10/11—Revision 0: Initial Version

Continued from first page) Circuits from the Lab circuits are intended only for use with Analog Devices products and are the intellectual property of Analog Devices or its licensors. While you may use the Circuits from the Lab circuits in the design of your product, no other license is granted by implication or otherwise under any patents or other intellectual property by application or use of the Circuits from the Lab circuits. Information furnished by Analog Devices is believed to be accurate and reliable. However, "Circuits from the Lab" are supplied "as is" and without warranties of any kind, express, implied, or statutory including, but not limited to, any implied warranty of merchantability, noninfringement or fitness for a particular purpose and no responsibility is assumed by Analog Devices for their use, nor for any infringements of patents or other rights of third parties that may result from their use. Analog Devices reserves the right to change any Circuits from the Lab circuits at any time without notice but is under no obligation to do so.

©2011 Analog Devices, Inc. All rights reserved. Trademarks and registered trademarks are the property of their respective owners.
CN09736-0-10/11(0)



www.analog.com



Стандарт Электрон Связь

Мы молодая и активно развивающаяся компания в области поставок электронных компонентов. Мы поставляем электронные компоненты отечественного и импортного производства напрямую от производителей и с крупнейших складов мира.

Благодаря сотрудничеству с мировыми поставщиками мы осуществляем комплексные и плановые поставки широчайшего спектра электронных компонентов.

Собственная эффективная логистика и склад в обеспечивает надежную поставку продукции в точно указанные сроки по всей России.

Мы осуществляем техническую поддержку нашим клиентам и предпродажную проверку качества продукции. На все поставляемые продукты мы предоставляем гарантию .

Осуществляем поставки продукции под контролем ВП МО РФ на предприятия военно-промышленного комплекса России , а также работаем в рамках 275 ФЗ с открытием отдельных счетов в уполномоченном банке. Система менеджмента качества компании соответствует требованиям ГОСТ ISO 9001.

Минимальные сроки поставки, гибкие цены, неограниченный ассортимент и индивидуальный подход к клиентам являются основой для выстраивания долгосрочного и эффективного сотрудничества с предприятиями радиоэлектронной промышленности, предприятиями ВПК и научно-исследовательскими институтами России.

С нами вы становитесь еще успешнее!

Наши контакты:

Телефон: +7 812 627 14 35

Электронная почта: sales@st-electron.ru

Адрес: 198099, Санкт-Петербург,
Промышленная ул, дом № 19, литера Н,
помещение 100-Н Офис 331