



microPower, Single-Supply, CMOS Instrumentation Amplifier

FEATURES

- **LOW QUIESCENT CURRENT:** 40µA/channel
Shut Down: < 1µA
- **HIGH GAIN ACCURACY:** G = 5, 0.02%,
2ppm/°C
- **GAIN SET WITH EXTERNAL RESISTORS**
- **LOW OFFSET VOLTAGE:** ±200µV
- **HIGH CMRR:** 94dB
- **LOW BIAS CURRENT:** 10pA
- **BANDWIDTH:** 500kHz, G = 5V/V
- **RAIL-TO-RAIL OUTPUT SWING:** (V+) – 0.02V
- **WIDE TEMPERATURE RANGE:**
–55°C to +125°C
- **SINGLE VERSION IN MSOP-8 PACKAGE AND
DUAL VERSION IN TSSOP-14 PACKAGE**

DESCRIPTION

The INA321 family is a series of rail-to-rail output, micropower CMOS instrumentation amplifiers that offer wide-range, single-supply, as well as bipolar-supply operation. The INA321 family provides low-cost, low-noise amplification of differential signals with micropower current consumption of 40µA. When shutdown, the INA321 has a quiescent current of less than 1µA. Returning to normal operations within microseconds, the shutdown feature makes the INA321 optimal for low-power battery or multiplexing applications.

Configured internally for 5V/V gain, the INA321 offers exceptional flexibility with user-programmable external gain resistors. The INA321 reduces common-mode error over frequency and with CMRR remaining high up to 3kHz, line noise and line harmonics are rejected.

The low-power design does not compromise on bandwidth or slew rate, making the INA321 ideal for driving sample Analog-to-Digital (A/D) converters as well as general-purpose applications. With high precision, low cost, and small packaging, the INA321 outperforms discrete designs, while offering reliability and performance.

APPLICATIONS

- **INDUSTRIAL SENSOR AMPLIFIERS:**
Bridge, RTD, Thermistor, Position
- **PHYSIOLOGICAL AMPLIFIERS:**
ECG, EEG, EMG
- **A/D CONVERTER SIGNAL CONDITIONING**
- **DIFFERENTIAL LINE RECEIVERS WITH GAIN**
- **FIELD UTILITY METERS**
- **PCMCIA CARDS**
- **COMMUNICATION SYSTEMS**
- **TEST EQUIPMENT**
- **AUTOMOTIVE INSTRUMENTATION**

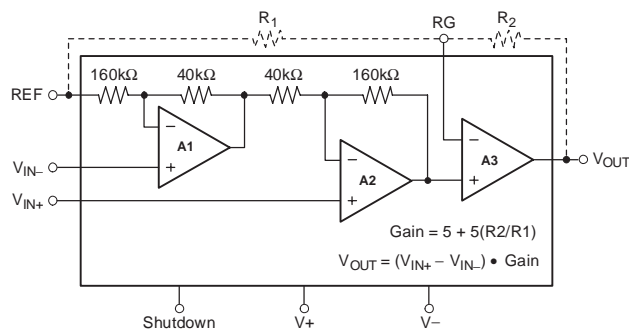
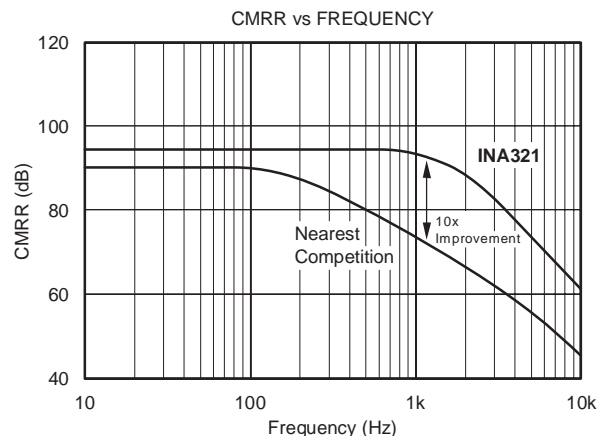

Please be aware that an important notice concerning availability, standard warranty, and use in critical applications of Texas Instruments semiconductor products and disclaimers thereto appears at the end of this data sheet.

All trademarks are the property of their respective owners.

ABSOLUTE MAXIMUM RATINGS(1)

Supply Voltage, V+ to V-	7.5V
Signal Input Terminals Voltage(2) ... (V-) - (0.5V) to (V+) + (0.5V)	
Current(2)	10mA
Output Short-Circuit(3)	Continuous
Operating Temperature	-65°C to +150°C
Storage Temperature	-65°C to +150°C
Junction Temperature	+150°C

- (1) Stresses above these ratings may cause permanent damage. Exposure to absolute maximum conditions for extended periods may degrade device reliability. These are stress ratings only, and functional operation of the device at these or any other conditions beyond those specified is not supported.
- (2) Input terminals are diode-clamped to the power-supply rails. Input signals that can swing more than 0.5V beyond the supply rails should be current limited to 10mA or less.
- (3) Short-circuit to ground, one amplifier per package.



ELECTROSTATIC DISCHARGE SENSITIVITY

This integrated circuit can be damaged by ESD. Texas Instruments recommends that all integrated circuits be handled with appropriate precautions. Failure to observe proper handling and installation procedures can cause damage.

ESD damage can range from subtle performance degradation to complete device failure. Precision integrated circuits may be more susceptible to damage because very small parametric changes could cause the device not to meet its published specifications.

PACKAGE/ORDERING INFORMATION(1)

PRODUCT	PACKAGE-LEAD	PACKAGE DESIGNATOR	SPECIFIED TEMPERATURE RANGE	PACKAGE MARKING	ORDERING NUMBER	TRANSPORT MEDIA, QUANTITY
SINGLE						
INA321E	MSOP-8	DGK	-55°C to +125°C	C21	INA321E/250	Tape and Reel, 250
"	"	"	"	"	INA321E/2K5	Tape and Reel, 2500
INA321EA	MSOP-8	DGK	-55°C to +125°C	C21	INA321EA/250	Tape and Reel, 250
"	"	"	"	"	INA321EA/2K5	Tape and Reel, 3000
DUAL						
INA2321EA	TSSOP-14	PW	-55°C to +125°C	INA2321EA	INA2321EA/250	Tape and Reel, 250
"	"	"	"	"	INA2321EA/2K5	Tape and Reel, 2500

(1) For the most current package and ordering information, see the Package Option Addendum located at the end of this data sheet.

PIN CONFIGURATIONS

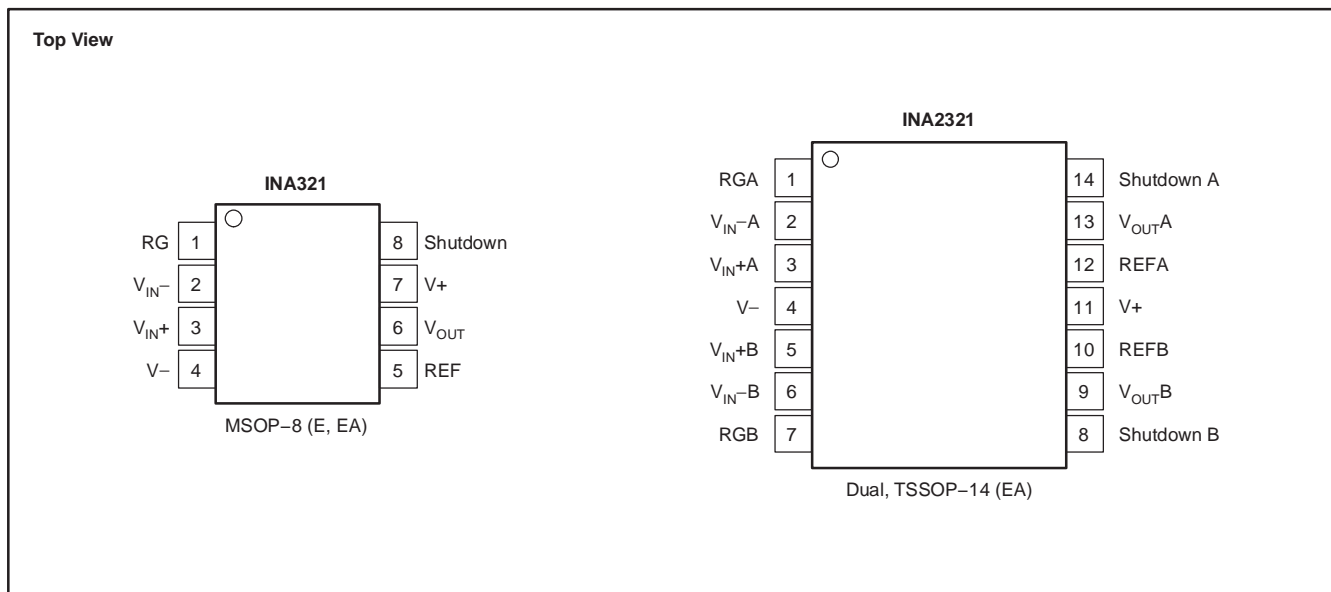

ELECTRICAL CHARACTERISTICS: $V_S = +2.7V$ to $+5.5V$

BOLDFACE limits apply over the specified temperature range, $T_A = -55^\circ C$ to $+125^\circ C$.

At $T_A = +25^\circ C$, $R_L = 25k\Omega$, $G = 25$, and I_A common = $V_S/2$, unless otherwise noted.

PARAMETER	CONDITIONS	INA321E			INA321EA INA2321EA			UNIT
		MIN	TYP	MAX	MIN	TYP	MAX	
INPUT								
Input Offset Voltage, RTI	$V_S = +5V$		± 0.2	± 0.5		*	1	mV
Over Temperature				± 2.2		*	2.5	mV
vs Temperature			± 7			*		$\mu V/^\circ C$
vs Power Supply	$V_S = +2.7V$ to $+5.5V$		± 50	± 200		*	*	$\mu V/V$
Over Temperature				± 220		*	*	$\mu V/V$
Long-Term Stability			± 0.4			*		$\mu V/month$
Input Impedance			$10^{13} \parallel 3$			*		$\Omega \parallel pF$
Input Common-Mode Range	$V_S = 2.7V$	0.35		1.5	*		*	V
	$V_S = 5V$	0.55		3.8	*		*	V
Common-Mode Rejection	$V_S = 5V, V_{CM} = 0.55V$ to $3.8V$	90	94		80	*		dB
Over Temperature	$V_S = 5V, V_{CM} = 0.55V$ to $3.8V$	77			75			dB
	$V_S = 2.7V, V_{CM} = 0.35V$ to $1.5V$		94			*		dB
Crosstalk, Dual			110			*		dB
INPUT BIAS CURRENT								
Bias Current			± 0.5	± 10		*	*	pA
Offset Current			± 0.5	± 10		*	*	pA
NOISE, RTI								
Voltage Noise: $f = 10Hz$	$R_S = 0\Omega$		500			*		nV/\sqrt{Hz}
$f = 100Hz$			190			*		nV/\sqrt{Hz}
$f = 1kHz$			100			*		nV/\sqrt{Hz}
$f = 0.1Hz$ to $10Hz$			20			*		μV_{PP}
Current Noise: $f = 1kHz$			3			*		fA/\sqrt{Hz}
GAIN⁽¹⁾								
Gain Equation, Externally Set	$G > 5$		$G = 5 + 5 (R2/R1)$			*		
Range of Gain		5		1000	*		*	V/V
Gain Error			± 0.02	± 0.1		*	*	%
vs Temperature	$G = 5$		± 2	± 10		*	*	ppm/ $^\circ C$
Nonlinearity	$G = 25, V_S = 5V, V_O = 0.05$ to 4.95		± 0.001	± 0.010		*	*	% of FS
Over Temperature			± 0.002	± 0.015		*	*	% of FS
OUTPUT								
Output Voltage Swing from Rail ^(2, 5)	$G \geq 10$	50	25		*	*		mV
Over Temperature		50			*	*		mV
Capacitance Load Drive		See Typical Characteristic ⁽³⁾				*		pF
Short-Circuit Current			8			*		mA
			16			*		mA

NOTE: * Specification is same as INA321E.

(1) Does not include errors from external gain setting resistors.

(2) Output voltage swings are measured between the output and power-supply rails.

(3) See typical characteristic *Percent Overshoot vs Load Capacitance*.

(4) See typical characteristic *Shutdown Voltage vs Supply Voltage*.

(5) Output does not swing to positive rail if gain is less than 10.

ELECTRICAL CHARACTERISTICS: $V_S = +2.7V$ to $+5.5V$ (continued)

BOLDFACE limits apply over the specified temperature range, $T_A = -55^\circ C$ to $+125^\circ C$.

At $T_A = +25^\circ C$, $R_L = 25k\Omega$, $G = 25$, and I_A common = $V_S/2$, unless otherwise noted.

PARAMETER	CONDITIONS	INA321E			INA321EA INA2321EA			UNIT	
		MIN	TYP	MAX	MIN	TYP	MAX		
FREQUENCY RESPONSE									
Bandwidth, -3dB	BW	G = 5				500		*	kHz
Slew Rate	SR	$V_S = 5V, G = 25$				0.4		*	V/ μs
Settling Time, 0.1%	t_S	G = 5, $C_L = 50pF, V_O = 2V$ step				8		*	μs
0.01%						12		*	μs
Overload Recovery		50% Input Overload G = 25				2		*	μs
POWER SUPPLY									
Specified Voltage Range		+2.7		+5.5	*		*		V
Operating Voltage Range			+2.5 to +5.5			*			V
Quiescent Current	I_Q	per Channel, $V_{SD} > 2.5^{(4)}$				40	60	*	μA
Over Temperature						70		*	μA
Shutdown Quiescent Current	I_{SD}	per Channel, $V_{SD} > 0.8^{(4)}$				0.01	1	*	μA
TEMPERATURE RANGE									
Specified Range		-55		+125	*		*		$^\circ C$
Operating/Storage Range		-65		+150	*		*		$^\circ C$
Thermal Resistance	θ_{JA}	MSOP-8, TSSOP-14 Surface-Mount				150		*	$^\circ C/W$

NOTE: * Specification is same as INA321E.

- (1) Does not include errors from external gain setting resistors.
- (2) Output voltage swings are measured between the output and power-supply rails.
- (3) See typical characteristic *Percent Overshoot vs Load Capacitance*.
- (4) See typical characteristic *Shutdown Voltage vs Supply Voltage*.
- (5) Output does not swing to positive rail if gain is less than 10.

TYPICAL CHARACTERISTICS

At $T_A = +25^\circ\text{C}$, $V_S = 5\text{V}$, $V_{CM} = 1/2V_S$, $R_L = 25\text{k}\Omega$, and $C_L = 50\text{pF}$, unless otherwise noted.

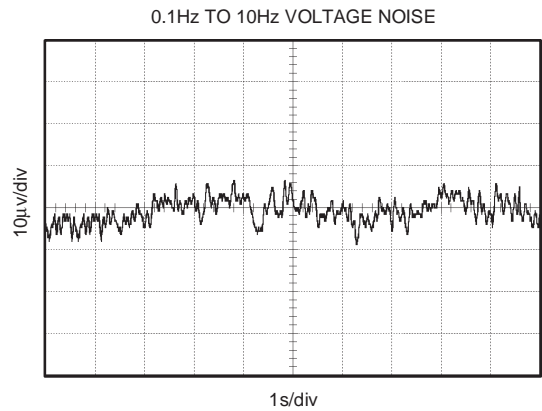
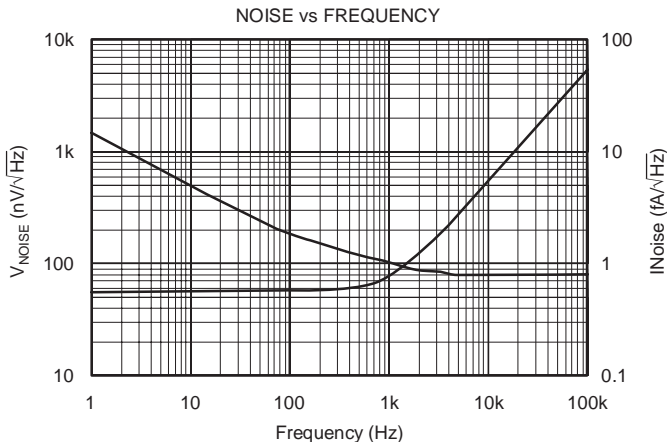
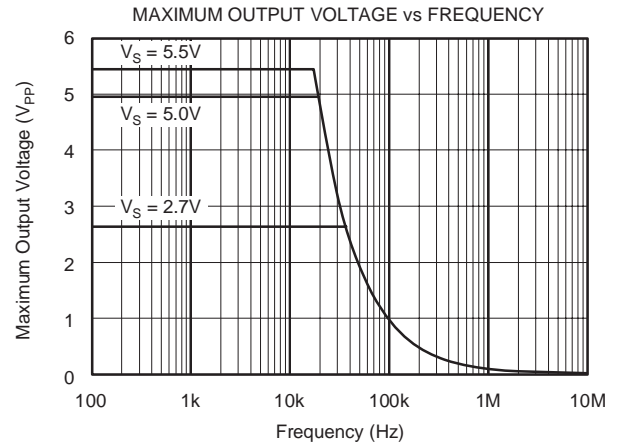
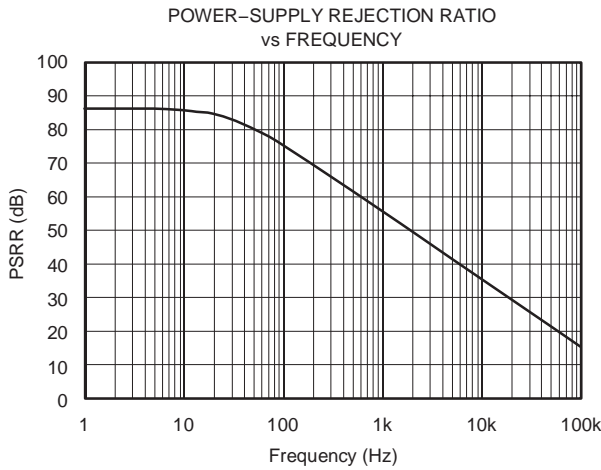
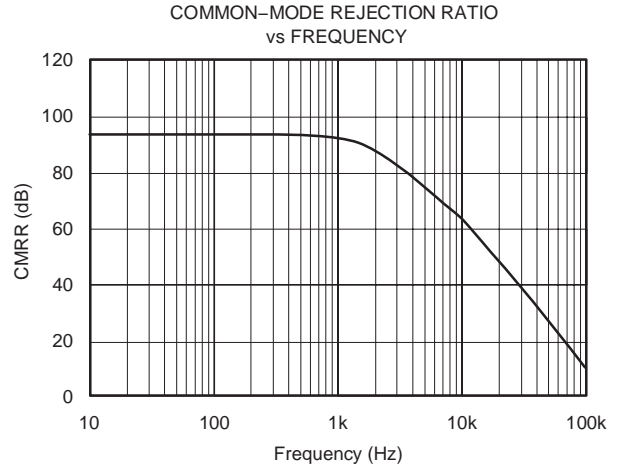
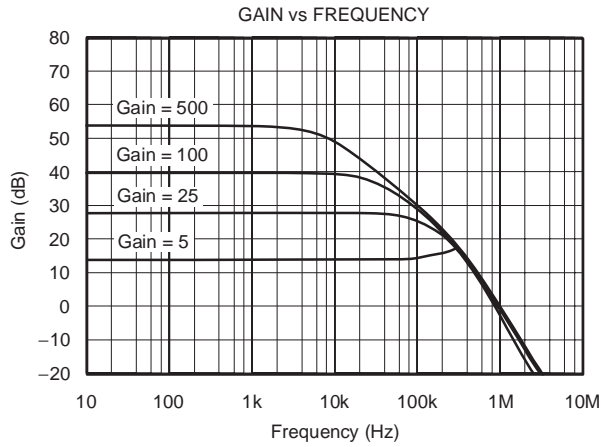

TYPICAL CHARACTERISTICS (continued)

At $T_A = +25^\circ\text{C}$, $V_S = 5\text{V}$, $V_{CM} = 1/2V_S$, $R_L = 25\text{k}\Omega$, and $C_L = 50\text{pF}$, unless otherwise noted.

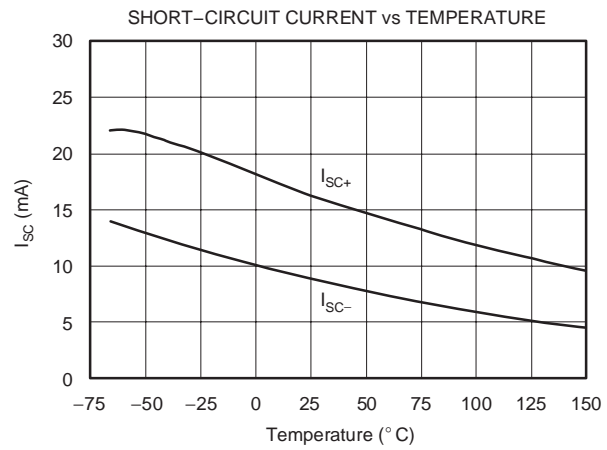
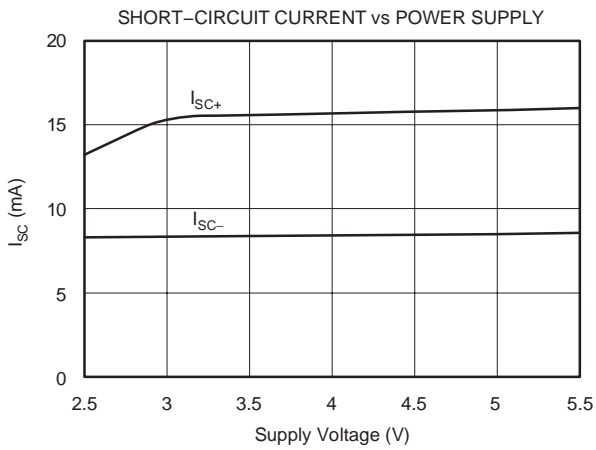
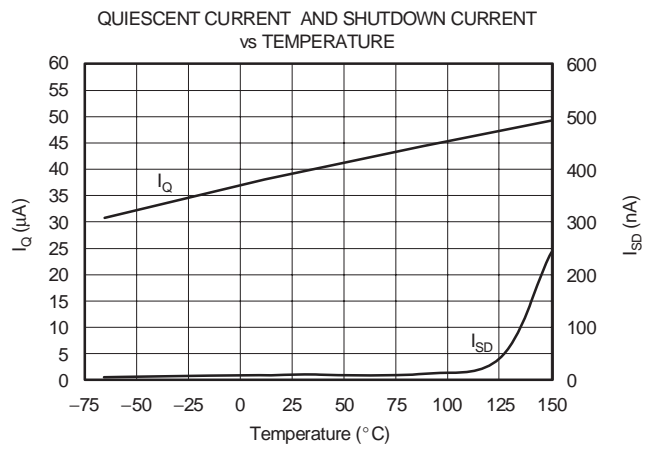
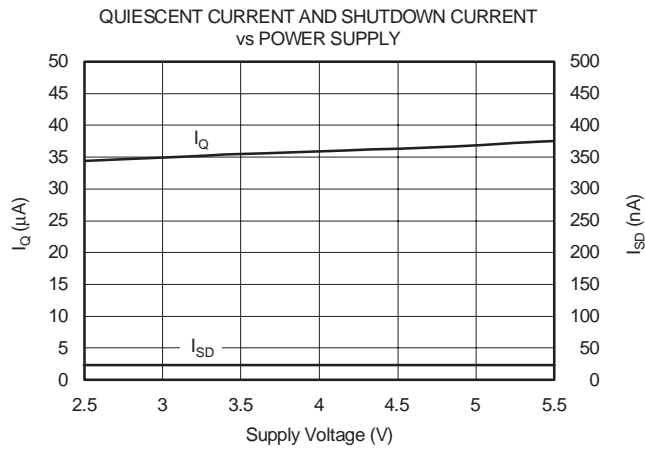
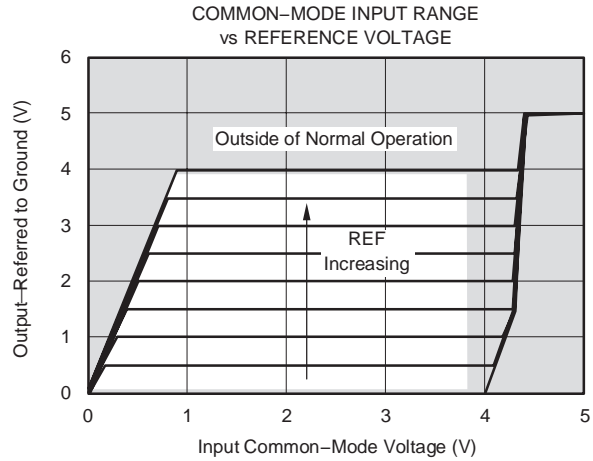
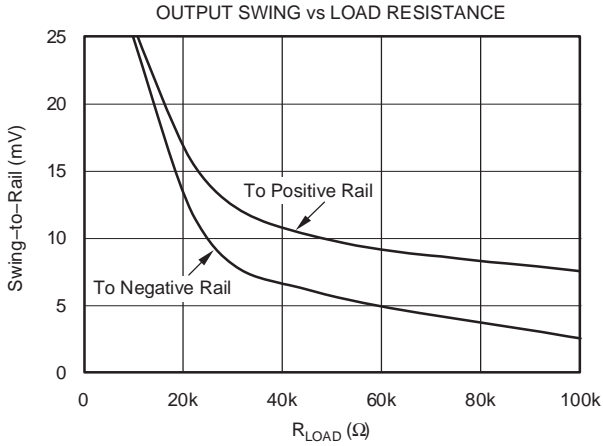

TYPICAL CHARACTERISTICS (continued)

At $T_A = +25^\circ\text{C}$, $V_S = 5\text{V}$, $V_{CM} = 1/2V_S$, $R_L = 25\text{k}\Omega$, and $C_L = 50\text{pF}$, unless otherwise noted.

SMALL-SIGNAL STEP RESPONSE (G = 5)

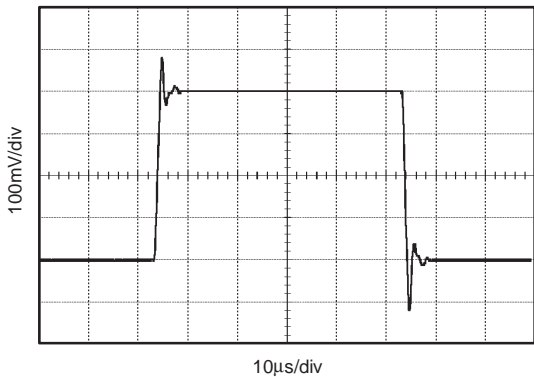

SMALL-SIGNAL STEP RESPONSE (G = 100)

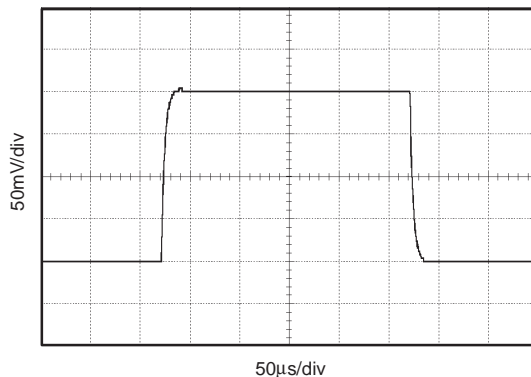

SMALL-SIGNAL STEP RESPONSE
(G = 5, $C_L = 1000\text{pF}$)

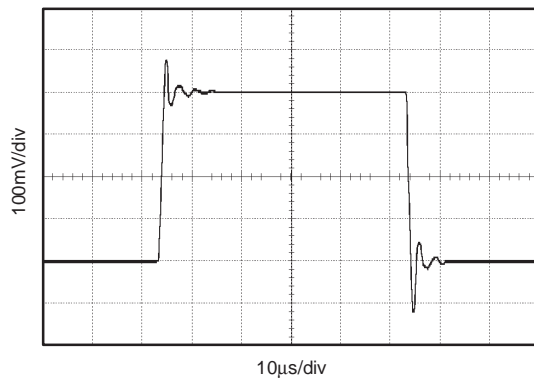

SMALL-SIGNAL STEP RESPONSE
(G = 100, $C_L = 1000\text{pF}$)

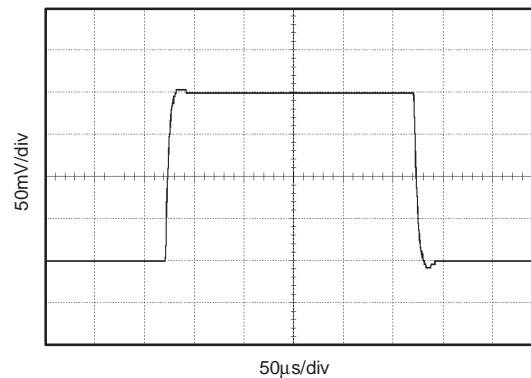

SMALL-SIGNAL STEP RESPONSE
(G = 100, $C_L = 5000\text{pF}$)

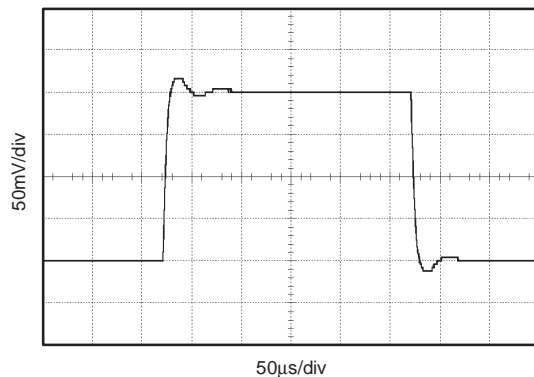

LARGE-SIGNAL STEP RESPONSE
(G = 25, $C_L = 50\text{pF}$)

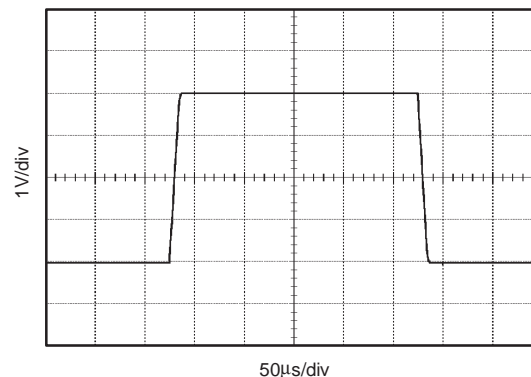

TYPICAL CHARACTERISTICS (continued)

At $T_A = +25^\circ\text{C}$, $V_S = 5\text{V}$, $V_{CM} = 1/2V_S$, $R_L = 25\text{k}\Omega$, and $C_L = 50\text{pF}$, unless otherwise noted.

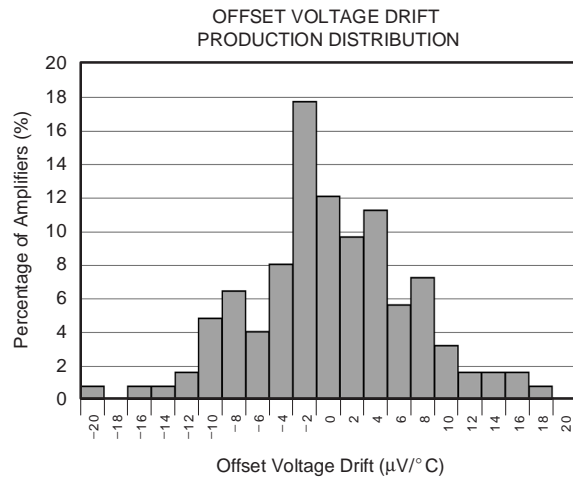
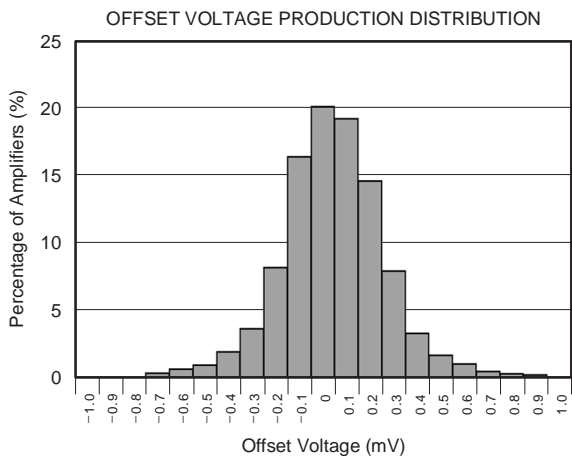
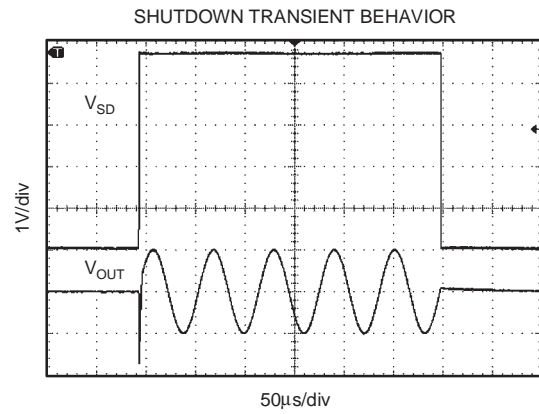
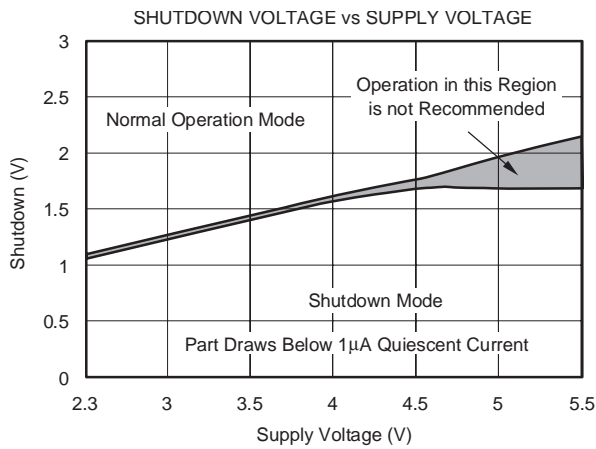
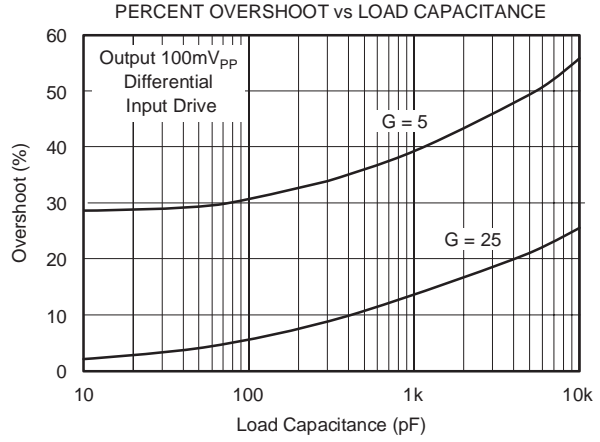
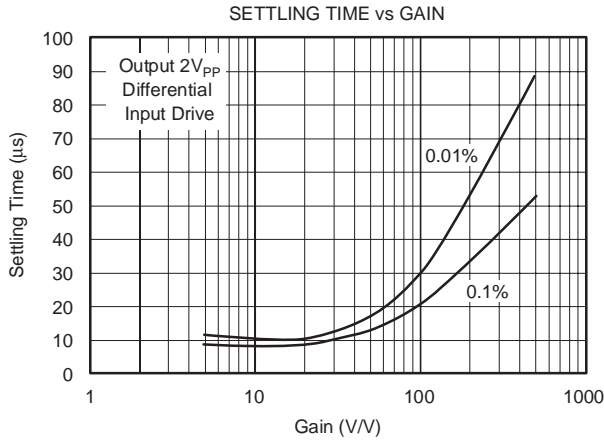

TYPICAL CHARACTERISTICS (continued)

At $T_A = +25^\circ\text{C}$, $V_S = 5\text{V}$, $V_{CM} = 1/2V_S$, $R_L = 25\text{k}\Omega$, and $C_L = 50\text{pF}$, unless otherwise noted.

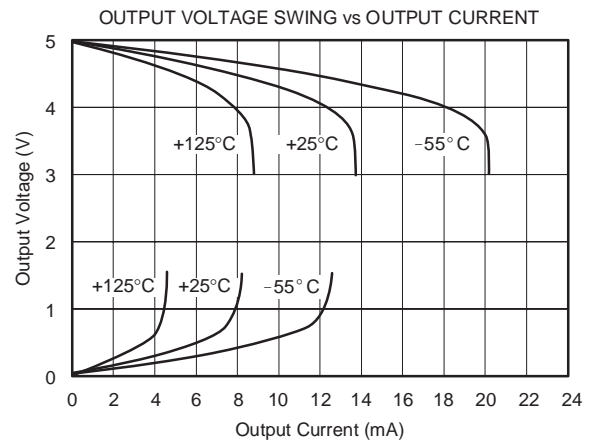
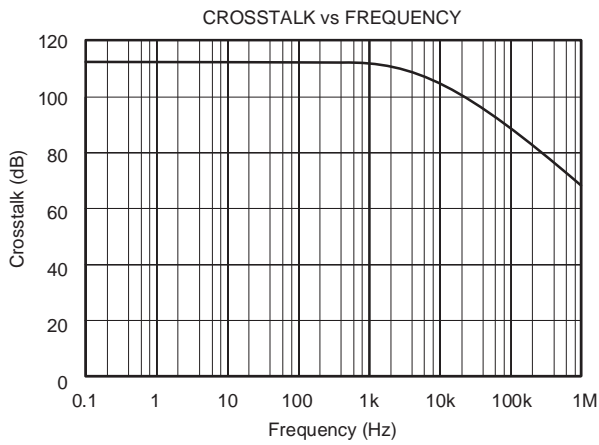
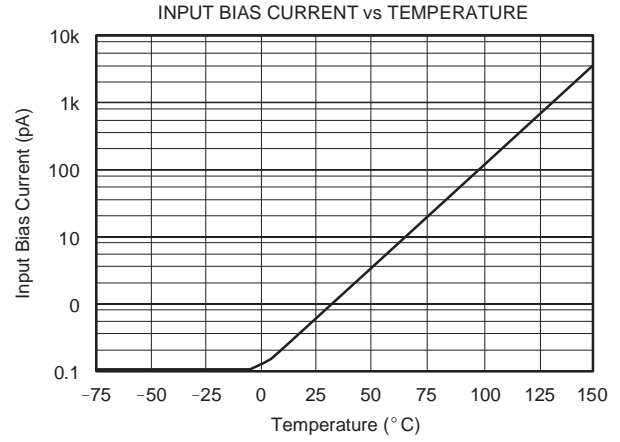
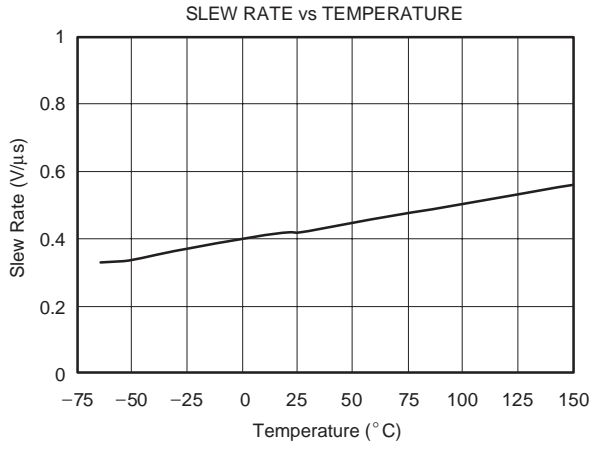

APPLICATIONS INFORMATION

The INA321 is a modified version of the classic *two op amp* instrumentation amplifier, with an additional gain amplifier.

Figure 1 shows the basic connections for the operation of the INA321 and INA2321. The power supply should be capacitively decoupled with 0.1µF capacitors as close to the INA321 as possible for noisy or high-impedance applications.

The output is referred to the reference terminal, which must be at least 1.2V below the positive supply rail.

OPERATING VOLTAGE

The INA321 family is fully specified over a supply range of +2.7V to +5.5V, with key parameters assured over the temperature range of -55°C to +125°C. Parameters that vary significantly with operating conditions, such as load conditions or temperature, are shown in the Typical Characteristics.

The INA321 may be operated on a single supply. Figure 2 shows a bridge amplifier circuit operated from a single +5V supply. The bridge provides a small differential voltage riding on an input common-mode voltage.

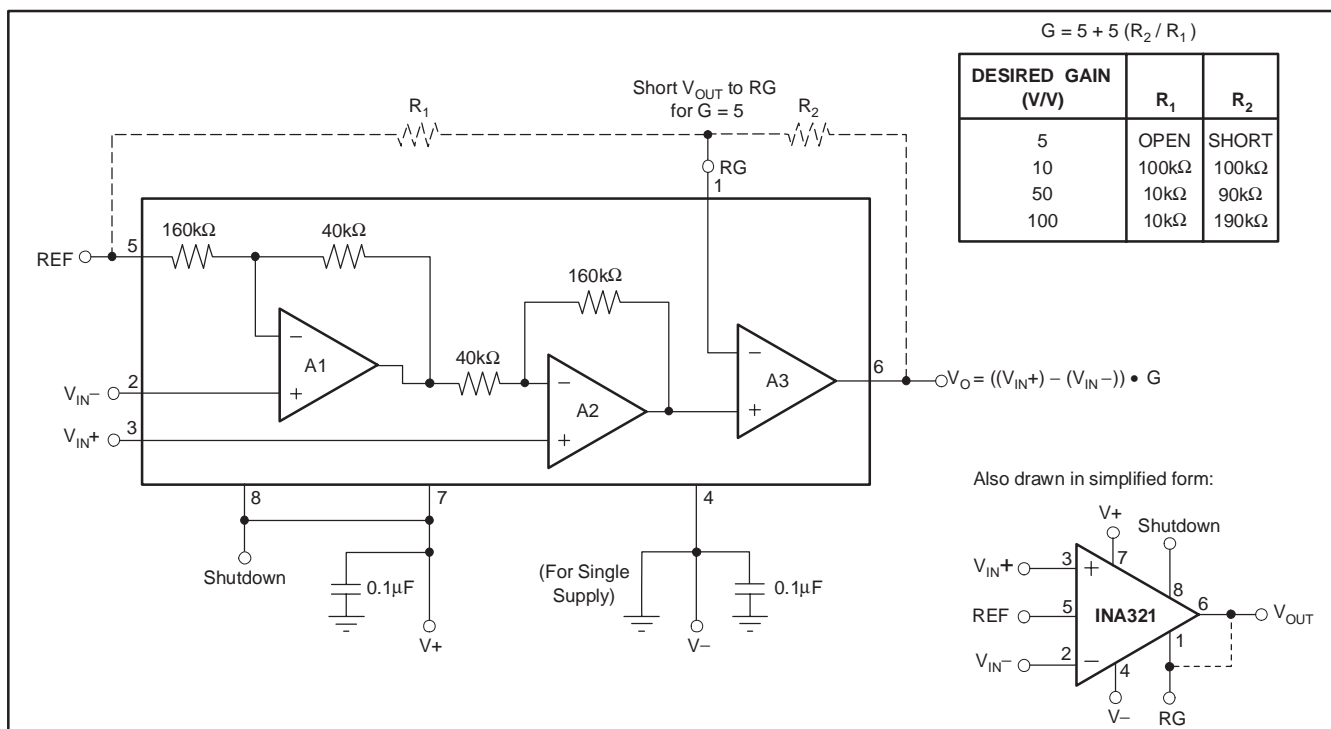

Figure 1. Basic Connections

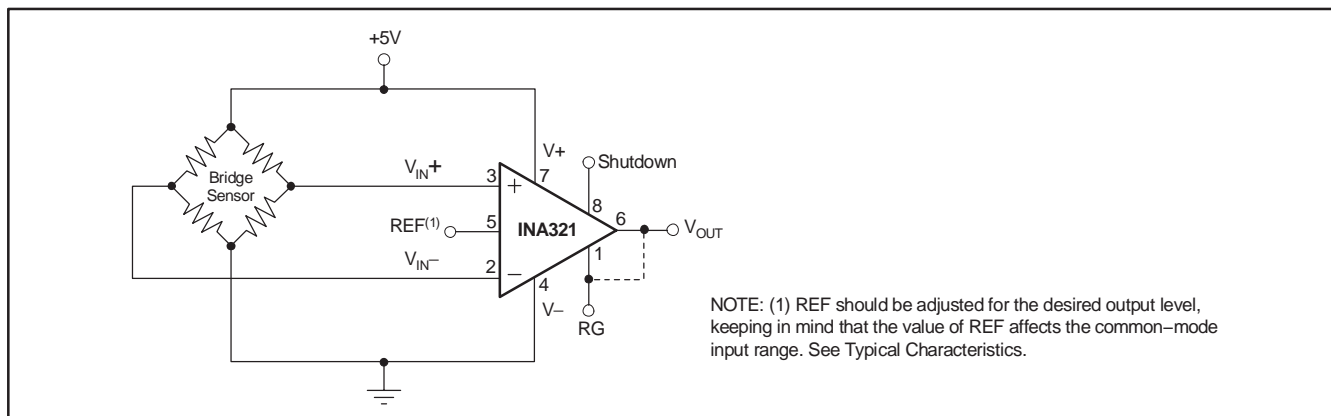

Figure 2. Bridge Amplifier of the INA321

SETTING THE GAIN

The ratio of R_2 to R_1 , or the impedance between pins 1, 5, and 6, determines the gain of the INA321. With an internally set gain of 5, the INA321 can be programmed for gains greater than 5 according to the following equation:

$$G = 5 + 5 (R_2/R_1)$$

The INA321 is designed to provide accurate gain, with gain error assured to be less than 0.1%. Setting gain with matching TC resistors will minimize gain drift. Errors from external resistors will add directly to the gain error, and may become dominant error sources.

INPUT COMMON-MODE RANGE

The upper limit of the common-mode input range is set by the common-mode input range of the second amplifier, A2, to 1.2V below positive supply. Under most conditions, the amplifier operates beyond this point with reduced performance. The lower limit of the input range is bounded by the output swing of amplifier A1, and is a function of the reference voltage according to the following equation:

$$V_{OA1} = 5/4 V_{CM} - 1/4 V_{REF}$$

(See Typical Characteristics for *Input Common-Mode Range vs Reference Voltage*).

REFERENCE

The reference terminal defines the zero output voltage level. In setting the reference voltage, the common-mode input of A3 should be considered according to the following equation:

$$V_{OA2} = V_{REF} + 5 (V_{IN+} - V_{IN-})$$

For optimal operation, V_{OA2} should be less than $V_{DD} - 1.2V$.

The reference pin requires a low-impedance connection. As little as 160Ω in series with the reference pin will degrade the CMRR to 80dB. The reference pin may be used to compensate for the offset voltage (see *Offset Trimming* section). The reference voltage level also influences the common-mode input range (see *Common-Mode Input Range* section).

INPUT BIAS CURRENT RETURN

With a high input impedance of $10^{13}\Omega$, the INA321 is ideal for use with high-impedance sources. The input bias current of less than 10pA makes the INA321 nearly independent of input impedance and ideal for low-power applications.

For proper operation, a path must be provided for input bias currents for both inputs. Without input bias current paths, the inputs will *float* to a potential that exceeds common-mode range and the input amplifier will saturate.

Figure 3 shows how bias current path can be provided in the cases of microphone applications, thermistor applications, ground returns, and dc-coupled resistive bridge applications.

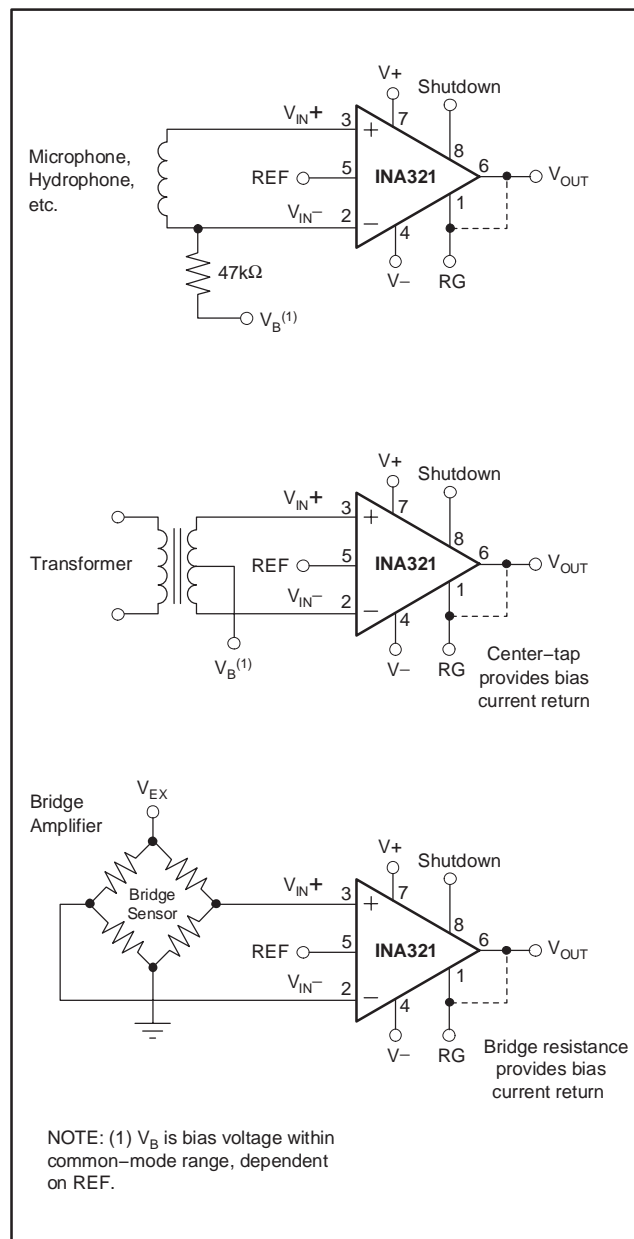

Figure 3. Providing an Input Common-Mode Path

When differential source impedance is low, the bias current return path can be connected to one input. With higher source impedance, two equal resistors will provide a balanced input. The advantages are lower input offset voltage due to bias current flowing through the source impedance and better high-frequency gain.

OUTPUT BUFFERING

The INA321 is optimized for a load impedance of 10k Ω or greater. For higher output current the INA321 can be buffered using the OPA340, as shown in Figure 4. The OPA340 can swing within 50mV of the supply rail, driving a 600 Ω load. The OPA340 is available in the tiny MSOP-8 package.

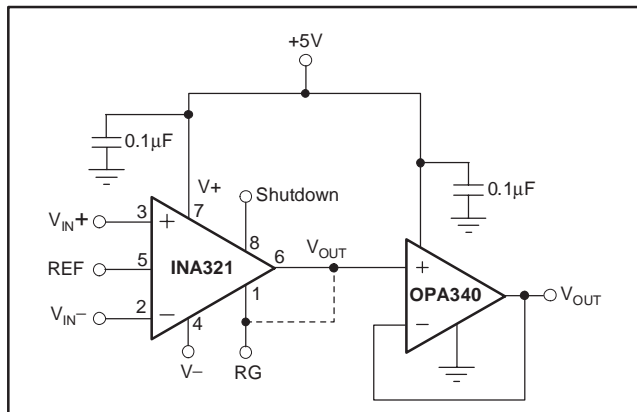

Figure 4. Output Buffering Circuit. Able to drive loads as low as 600 Ω .

SHUTDOWN MODE

The shutdown pin of the INA321 is nominally connected to V+. When the pin is pulled below 0.8V on a 5V supply, the INA321 goes into sleep mode within nanoseconds. For actual shutdown threshold, see the Typical Characteristic curve, *Shutdown Voltage vs Supply Voltage*. Drawing less than 1 μ A of current, and returning from sleep mode in microseconds, the shutdown feature is useful for portable applications. Once in sleep-mode, the amplifier has high output impedance, making the INA321 suitable for multiplexing.

RAIL-TO-RAIL OUTPUT

A class AB output stage with common-source transistors is used to achieve rail-to-rail output for gains of 10 or greater. For resistive loads greater than 25k Ω , the output voltage can swing to within a few millivolts of the supply rail while maintaining low gain error. For heavier loads and over temperature, see the Typical Characteristic curve, *Output Voltage Swing vs Output Current*. The INA321's

low output impedance at high frequencies makes it suitable for directly driving Capacitive Digital-to-Analog (CDAC) input A/D converters, as shown in Figure 5.

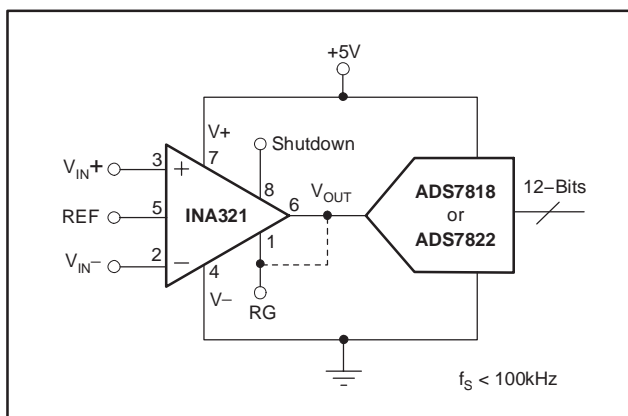

Figure 5. INA321 Directly Drives a Capacitive-Input, A/D Converter

OFFSET TRIMMING

The INA321 is laser-trimmed for low offset voltage. In the event that external offset adjustment is required, the offset can be adjusted by applying a correction voltage to the reference terminal. Figure 6 shows an optional circuit for trimming offset voltage. The voltage applied to the REF terminal is added to the output signal. The gain from REF to V_{OUT} is +1. An op-amp buffer is used to provide low impedance at the REF terminal to preserve good common-mode rejection.

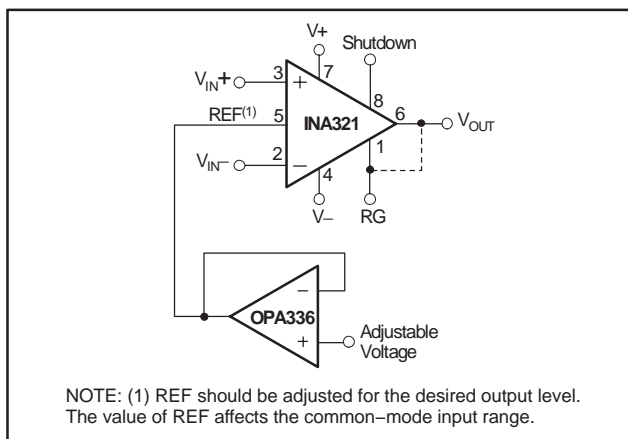

Figure 6. Optional Offset Trimming Voltage

INPUT PROTECTION

Device inputs are protected by ESD diodes that will conduct if the input voltages exceed the power supplies by more than 500mV. Momentary voltages greater than 500mV beyond the power supply can be tolerated if the current through the input pins is limited to 10mA. This is easily accomplished with input resistor R_{LIM} , as shown in Figure 7. Many input signals are inherently current-limited to less than 10mA; therefore, a limiting resistor is not required.

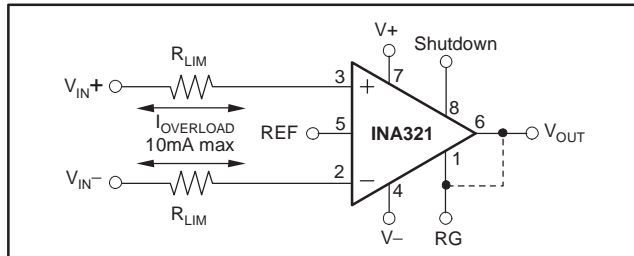

Figure 7. Input Protection

OFFSET VOLTAGE ERROR CALCULATION

The offset voltage (V_{OS}) of the INA321E is specified at a maximum of $500\mu\text{V}$ with a +5V power supply and the common-mode voltage at $V_S/2$. Additional specifications for power-supply rejection and common-mode rejection are provided to allow the user to easily calculate worst-case expected offset under the conditions of a given application.

Power-Supply Rejection Ratio (PSRR) is specified in $\mu\text{V}/\text{V}$. For the INA321, worst-case PSRR is $200\mu\text{V}/\text{V}$, which means for each volt of change in power supply, the offset may shift up to $200\mu\text{V}$. Common-Mode Rejection Ratio (CMRR) is specified in dB, which can be converted to $\mu\text{V}/\text{V}$ using the following equation:

$$\text{CMRR (in } \mu\text{V}/\text{V)} = 10[(\text{CMRR in dB})/-20] \cdot 10^6$$

For the INA321, the worst-case CMRR over the specified common-mode range is 90dB (at $G = 25$) or about $30\mu\text{V}/\text{V}$. This means that for every volt of change in common-mode, the offset will shift less than $30\mu\text{V}$.

These numbers can be used to calculate excursions from the specified offset voltage under different application conditions. For example, an application might configure the amplifier with a 3.3V supply with 1V common-mode. This configuration varies from the specified configuration, representing a 1.7V variation in power supply (5V in the offset specification versus 3.3V in the application) and a 0.65V variation in common-mode voltage from the specified $V_S/2$.

Calculation of the worst-case expected offset would be as follows:

$$\text{Adjusted } V_{OS} = \text{Maximum specified } V_{OS} + (\text{power-supply variation}) \cdot \text{PSRR} + (\text{common-mode variation}) \cdot \text{CMRR}$$

$$V_{OS} = 0.5\text{mV} + (1.7\text{V} \cdot 200\mu\text{V}) + (0.65\text{V} \cdot 30\mu\text{V}) = \pm 0.860\text{mV}$$

However, the typical value will be smaller, as seen in the Typical Characteristics.

FEEDBACK CAPACITOR IMPROVES RESPONSE

For optimum settling time and stability with high-impedance feedback networks, it may be necessary to add a feedback capacitor across the feedback resistor, R_F , as shown in Figure 8. This capacitor compensates for the zero created by the feedback network impedance and the INA321's RG-pin input capacitance (and any parasitic layout capacitance). The effect becomes more significant with higher impedance networks. Also, R_X and C_L can be added to reduce high-frequency noise.

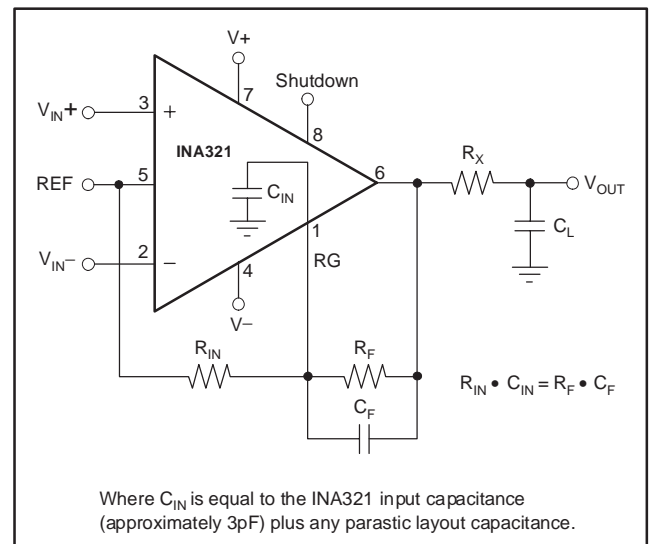

Figure 8. Feedback Capacitor Improves Dynamic Performance

It is suggested that a variable capacitor be used for the feedback capacitor since input capacitance may vary between instrumentation amplifiers, and layout capacitance is difficult to determine. For the circuit shown in Figure 8, the value of the variable feedback capacitor should be chosen by the following equation:

$$R_{IN} \cdot C_{IN} = R_F \cdot C_F$$

where C_{IN} is equal to the INA321's RG-pin input capacitance (typically 3pF) plus the layout capacitance. The capacitor can be varied until optimum performance is obtained.

APPLICATION CIRCUITS
Medical ECG Applications

Figure 9 shows the INA321 configured to serve as a low-cost ECG amplifier, suitable for moderate accuracy heart-rate applications such as fitness equipment. The input signals are obtained from the left and right arms of the patient. The common-mode voltage is set by two 2MΩ resistors. This potential, through a buffer, provides an

optional right leg drive. Filtering can be modified to suit application needs by changing the capacitor value of the output filter.

Low-Power, Single-Supply Data Acquisition Systems

Refer to Figure 5 to see the INA321 configured to drive an ADS7818. Functioning at frequencies of up to 500kHz, the INA321 is ideal for low-power data acquisition.

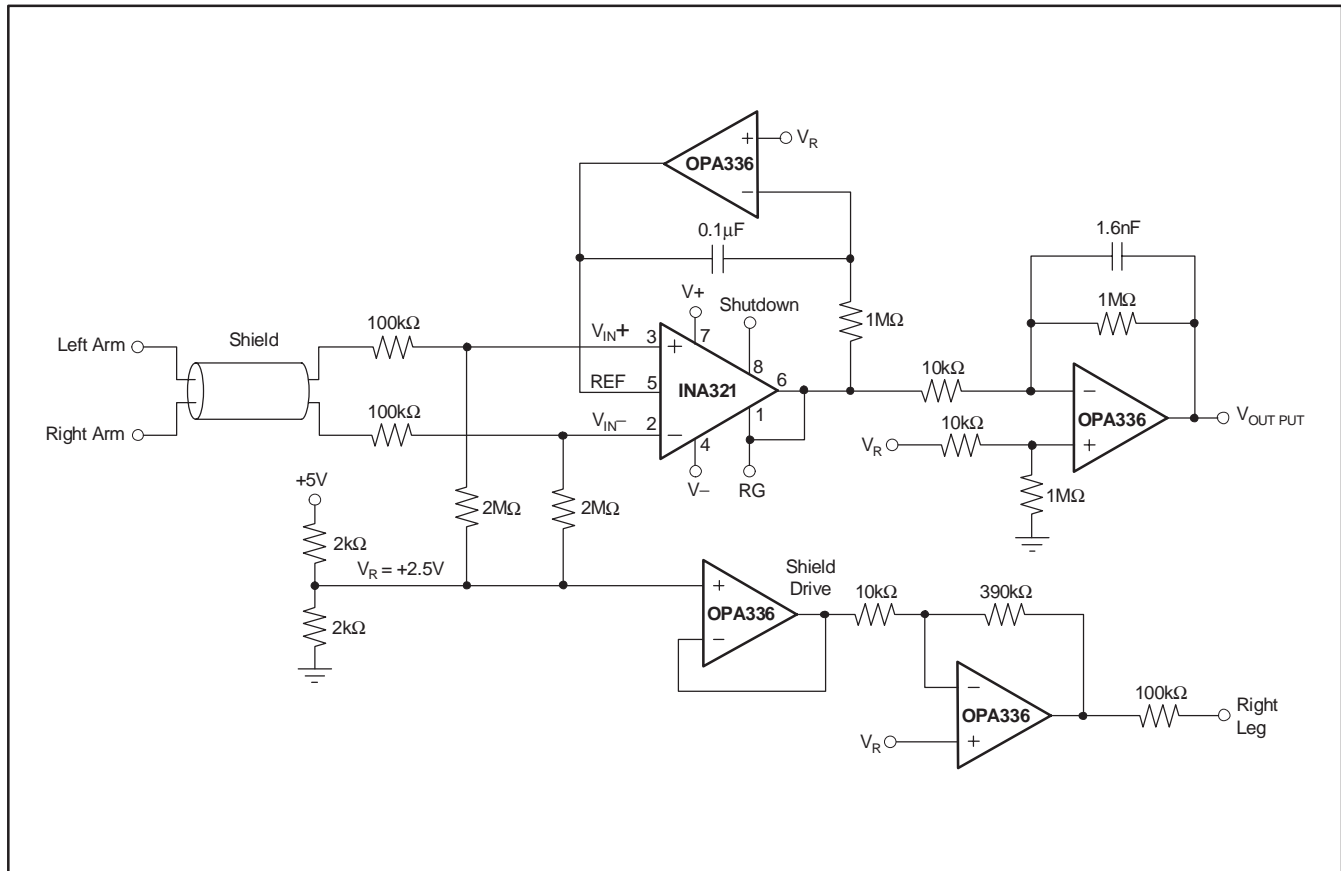

Figure 9. Simplified ECG Circuit for Medical Applications

PACKAGING INFORMATION

Orderable Device	Status ⁽¹⁾	Package Type	Package Drawing	Pins	Package Qty	Eco Plan ⁽²⁾	Lead/ Ball Finish	MSL Peak Temp ⁽³⁾	Samples (Requires Login)
INA2321EA/250	ACTIVE	TSSOP	PW	14	250	Green (RoHS & no Sb/Br)	CU NIPDAU	Level-1-260C-UNLIM	
INA2321EA/250G4	ACTIVE	TSSOP	PW	14	250	Green (RoHS & no Sb/Br)	CU NIPDAU	Level-1-260C-UNLIM	
INA2321EA/2K5	ACTIVE	TSSOP	PW	14	2500	Green (RoHS & no Sb/Br)	CU NIPDAU	Level-1-260C-UNLIM	
INA2321EA/2K5G4	ACTIVE	TSSOP	PW	14	2500	Green (RoHS & no Sb/Br)	CU NIPDAU	Level-1-260C-UNLIM	
INA321E/250	ACTIVE	VSSOP	DGK	8	250	Green (RoHS & no Sb/Br)	CU NIPDAUAG	Level-2-260C-1 YEAR	
INA321E/250G4	ACTIVE	VSSOP	DGK	8	250	Green (RoHS & no Sb/Br)	CU NIPDAUAG	Level-2-260C-1 YEAR	
INA321E/2K5	ACTIVE	VSSOP	DGK	8	2500	Green (RoHS & no Sb/Br)	CU NIPDAUAG	Level-2-260C-1 YEAR	
INA321E/2K5G4	ACTIVE	VSSOP	DGK	8	2500	Green (RoHS & no Sb/Br)	CU NIPDAUAG	Level-2-260C-1 YEAR	
INA321EA/250	ACTIVE	VSSOP	DGK	8	250	Green (RoHS & no Sb/Br)	CU NIPDAUAG	Level-2-260C-1 YEAR	
INA321EA/250G4	ACTIVE	VSSOP	DGK	8	250	Green (RoHS & no Sb/Br)	CU NIPDAUAG	Level-2-260C-1 YEAR	
INA321EA/2K5	ACTIVE	VSSOP	DGK	8	2500	Green (RoHS & no Sb/Br)	CU NIPDAUAG	Level-2-260C-1 YEAR	
INA321EA/2K5G4	ACTIVE	VSSOP	DGK	8	2500	Green (RoHS & no Sb/Br)	CU NIPDAUAG	Level-2-260C-1 YEAR	

⁽¹⁾ The marketing status values are defined as follows:

ACTIVE: Product device recommended for new designs.

LIFEBUY: TI has announced that the device will be discontinued, and a lifetime-buy period is in effect.

NRND: Not recommended for new designs. Device is in production to support existing customers, but TI does not recommend using this part in a new design.

PREVIEW: Device has been announced but is not in production. Samples may or may not be available.

OBSELETE: TI has discontinued the production of the device.

⁽²⁾ Eco Plan - The planned eco-friendly classification: Pb-Free (RoHS), Pb-Free (RoHS Exempt), or Green (RoHS & no Sb/Br) - please check <http://www.ti.com/productcontent> for the latest availability information and additional product content details.

TBD: The Pb-Free/Green conversion plan has not been defined.

Pb-Free (RoHS): TI's terms "Lead-Free" or "Pb-Free" mean semiconductor products that are compatible with the current RoHS requirements for all 6 substances, including the requirement that lead not exceed 0.1% by weight in homogeneous materials. Where designed to be soldered at high temperatures, TI Pb-Free products are suitable for use in specified lead-free processes.

Pb-Free (RoHS Exempt): This component has a RoHS exemption for either 1) lead-based flip-chip solder bumps used between the die and package, or 2) lead-based die adhesive used between the die and leadframe. The component is otherwise considered Pb-Free (RoHS compatible) as defined above.

Green (RoHS & no Sb/Br): TI defines "Green" to mean Pb-Free (RoHS compatible), and free of Bromine (Br) and Antimony (Sb) based flame retardants (Br or Sb do not exceed 0.1% by weight in homogeneous material)

⁽³⁾ MSL, Peak Temp. -- The Moisture Sensitivity Level rating according to the JEDEC industry standard classifications, and peak solder temperature.

Important Information and Disclaimer: The information provided on this page represents TI's knowledge and belief as of the date that it is provided. TI bases its knowledge and belief on information provided by third parties, and makes no representation or warranty as to the accuracy of such information. Efforts are underway to better integrate information from third parties. TI has taken and continues to take reasonable steps to provide representative and accurate information but may not have conducted destructive testing or chemical analysis on incoming materials and chemicals. TI and TI suppliers consider certain information to be proprietary, and thus CAS numbers and other limited information may not be available for release.

In no event shall TI's liability arising out of such information exceed the total purchase price of the TI part(s) at issue in this document sold by TI to Customer on an annual basis.

TAPE AND REEL INFORMATION

REEL DIMENSIONS



TAPE DIMENSIONS



A0	Dimension designed to accommodate the component width
B0	Dimension designed to accommodate the component length
K0	Dimension designed to accommodate the component thickness
W	Overall width of the carrier tape
P1	Pitch between successive cavity centers

TAPE AND REEL INFORMATION

*All dimensions are nominal

Device	Package Type	Package Drawing	Pins	SPQ	Reel Diameter (mm)	Reel Width W1 (mm)	A0 (mm)	B0 (mm)	K0 (mm)	P1 (mm)	W (mm)	Pin1 Quadrant
INA2321EA/250	TSSOP	PW	14	250	180.0	12.4	6.9	5.6	1.6	8.0	12.0	Q1
INA2321EA/2K5	TSSOP	PW	14	2500	330.0	12.4	6.9	5.6	1.6	8.0	12.0	Q1
INA321E/250	VSSOP	DGK	8	250	180.0	12.4	5.3	3.4	1.4	8.0	12.0	Q1
INA321E/2K5	VSSOP	DGK	8	2500	330.0	12.4	5.3	3.4	1.4	8.0	12.0	Q1
INA321EA/250	VSSOP	DGK	8	250	180.0	12.4	5.3	3.4	1.4	8.0	12.0	Q1
INA321EA/2K5	VSSOP	DGK	8	2500	330.0	12.4	5.3	3.4	1.4	8.0	12.0	Q1

TAPE AND REEL BOX DIMENSIONS

*All dimensions are nominal

Device	Package Type	Package Drawing	Pins	SPQ	Length (mm)	Width (mm)	Height (mm)
INA2321EA/250	TSSOP	PW	14	250	210.0	185.0	35.0
INA2321EA/2K5	TSSOP	PW	14	2500	367.0	367.0	35.0
INA321E/250	VSSOP	DGK	8	250	210.0	185.0	35.0
INA321E/2K5	VSSOP	DGK	8	2500	367.0	367.0	35.0
INA321EA/250	VSSOP	DGK	8	250	210.0	185.0	35.0
INA321EA/2K5	VSSOP	DGK	8	2500	367.0	367.0	35.0

DGK (S-PDSO-G8)

PLASTIC SMALL-OUTLINE PACKAGE



- NOTES:
- A. All linear dimensions are in millimeters.
 - B. This drawing is subject to change without notice.
 - C. Body length does not include mold flash, protrusions, or gate burrs. Mold flash, protrusions, or gate burrs shall not exceed 0.15 per end.
 - D. Body width does not include interlead flash. Interlead flash shall not exceed 0.50 per side.
 - E. Falls within JEDEC MO-187 variation AA, except interlead flash.



MECHANICAL DATA

PW (R-PDSO-G14)

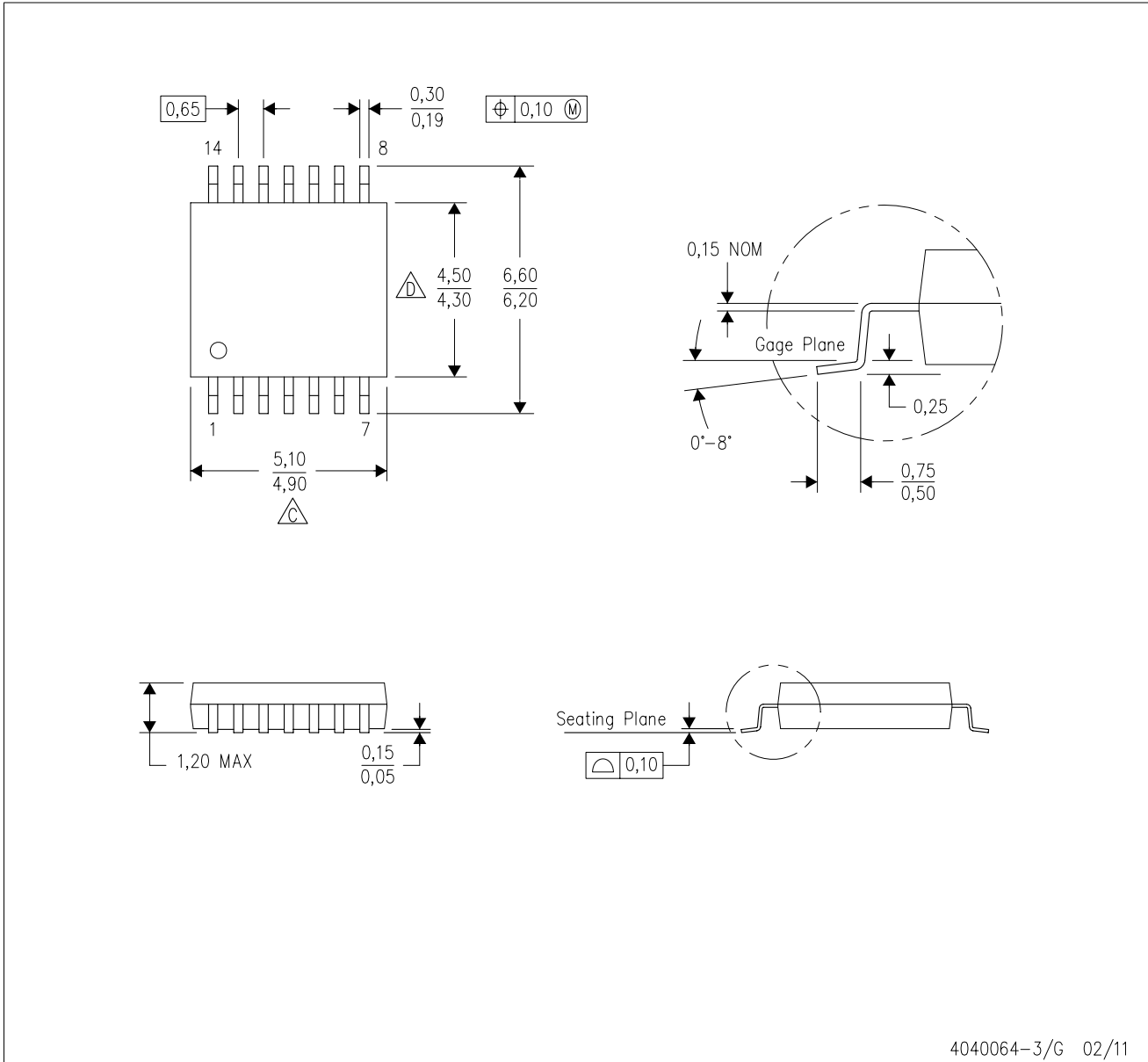
PLASTIC SMALL OUTLINE



4040064-3/G 02/11

- NOTES:
- A. All linear dimensions are in millimeters. Dimensioning and tolerancing per ASME Y14.5M-1994.
 - B. This drawing is subject to change without notice.
 -  Body length does not include mold flash, protrusions, or gate burrs. Mold flash, protrusions, or gate burrs shall not exceed 0,15 each side.
 -  Body width does not include interlead flash. Interlead flash shall not exceed 0,25 each side.
 - E. Falls within JEDEC MO-153

PW (R-PDSO-G14)

PLASTIC SMALL OUTLINE



- NOTES:
- All linear dimensions are in millimeters.
 - This drawing is subject to change without notice.
 - Publication IPC-7351 is recommended for alternate designs.
 - Laser cutting apertures with trapezoidal walls and also rounding corners will offer better paste release. Customers should contact their board assembly site for stencil design recommendations. Refer to IPC-7525 for other stencil recommendations.
 - Customers should contact their board fabrication site for solder mask tolerances between and around signal pads.

IMPORTANT NOTICE

Texas Instruments Incorporated and its subsidiaries (TI) reserve the right to make corrections, enhancements, improvements and other changes to its semiconductor products and services per JESD46C and to discontinue any product or service per JESD48B. Buyers should obtain the latest relevant information before placing orders and should verify that such information is current and complete. All semiconductor products (also referred to herein as "components") are sold subject to TI's terms and conditions of sale supplied at the time of order acknowledgment.

TI warrants performance of its components to the specifications applicable at the time of sale, in accordance with the warranty in TI's terms and conditions of sale of semiconductor products. Testing and other quality control techniques are used to the extent TI deems necessary to support this warranty. Except where mandated by applicable law, testing of all parameters of each component is not necessarily performed.

TI assumes no liability for applications assistance or the design of Buyers' products. Buyers are responsible for their products and applications using TI components. To minimize the risks associated with Buyers' products and applications, Buyers should provide adequate design and operating safeguards.

TI does not warrant or represent that any license, either express or implied, is granted under any patent right, copyright, mask work right, or other intellectual property right relating to any combination, machine, or process in which TI components or services are used. Information published by TI regarding third-party products or services does not constitute a license to use such products or services or a warranty or endorsement thereof. Use of such information may require a license from a third party under the patents or other intellectual property of the third party, or a license from TI under the patents or other intellectual property of TI.

Reproduction of significant portions of TI information in TI data books or data sheets is permissible only if reproduction is without alteration and is accompanied by all associated warranties, conditions, limitations, and notices. TI is not responsible or liable for such altered documentation. Information of third parties may be subject to additional restrictions.

Resale of TI components or services with statements different from or beyond the parameters stated by TI for that component or service voids all express and any implied warranties for the associated TI component or service and is an unfair and deceptive business practice. TI is not responsible or liable for any such statements.

Buyer acknowledges and agrees that it is solely responsible for compliance with all legal, regulatory and safety-related requirements concerning its products, and any use of TI components in its applications, notwithstanding any applications-related information or support that may be provided by TI. Buyer represents and agrees that it has all the necessary expertise to create and implement safeguards which anticipate dangerous consequences of failures, monitor failures and their consequences, lessen the likelihood of failures that might cause harm and take appropriate remedial actions. Buyer will fully indemnify TI and its representatives against any damages arising out of the use of any TI components in safety-critical applications.

In some cases, TI components may be promoted specifically to facilitate safety-related applications. With such components, TI's goal is to help enable customers to design and create their own end-product solutions that meet applicable functional safety standards and requirements. Nonetheless, such components are subject to these terms.

No TI components are authorized for use in FDA Class III (or similar life-critical medical equipment) unless authorized officers of the parties have executed a special agreement specifically governing such use.

Only those TI components which TI has specifically designated as military grade or "enhanced plastic" are designed and intended for use in military/aerospace applications or environments. Buyer acknowledges and agrees that any military or aerospace use of TI components which have **not** been so designated is solely at the Buyer's risk, and that Buyer is solely responsible for compliance with all legal and regulatory requirements in connection with such use.

TI has specifically designated certain components which meet ISO/TS16949 requirements, mainly for automotive use. Components which have not been so designated are neither designed nor intended for automotive use; and TI will not be responsible for any failure of such components to meet such requirements.

Products

Audio	www.ti.com/audio
Amplifiers	amplifier.ti.com
Data Converters	dataconverter.ti.com
DLP® Products	www.dlp.com
DSP	dsp.ti.com
Clocks and Timers	www.ti.com/clocks
Interface	interface.ti.com
Logic	logic.ti.com
Power Mgmt	power.ti.com
Microcontrollers	microcontroller.ti.com
RFID	www.ti-rfid.com
OMAP Mobile Processors	www.ti.com/omap
Wireless Connectivity	www.ti.com/wirelessconnectivity

Applications

Automotive and Transportation	www.ti.com/automotive
Communications and Telecom	www.ti.com/communications
Computers and Peripherals	www.ti.com/computers
Consumer Electronics	www.ti.com/consumer-apps
Energy and Lighting	www.ti.com/energy
Industrial	www.ti.com/industrial
Medical	www.ti.com/medical
Security	www.ti.com/security
Space, Avionics and Defense	www.ti.com/space-avionics-defense
Video and Imaging	www.ti.com/video

TI E2E Community e2e.ti.com



**Стандарт
Электрон
Связь**

Мы молодая и активно развивающаяся компания в области поставок электронных компонентов. Мы поставляем электронные компоненты отечественного и импортного производства напрямую от производителей и с крупнейших складов мира.

Благодаря сотрудничеству с мировыми поставщиками мы осуществляем комплексные и плановые поставки широчайшего спектра электронных компонентов.

Собственная эффективная логистика и склад в обеспечивает надежную поставку продукции в точно указанные сроки по всей России.

Мы осуществляем техническую поддержку нашим клиентам и предпродажную проверку качества продукции. На все поставляемые продукты мы предоставляем гарантию .

Осуществляем поставки продукции под контролем ВП МО РФ на предприятия военно-промышленного комплекса России , а также работаем в рамках 275 ФЗ с открытием отдельных счетов в уполномоченном банке. Система менеджмента качества компании соответствует требованиям ГОСТ ISO 9001.

Минимальные сроки поставки, гибкие цены, неограниченный ассортимент и индивидуальный подход к клиентам являются основой для выстраивания долгосрочного и эффективного сотрудничества с предприятиями радиоэлектронной промышленности, предприятиями ВПК и научно-исследовательскими институтами России.

С нами вы становитесь еще успешнее!

Наши контакты:

Телефон: +7 812 627 14 35

Электронная почта: sales@st-electron.ru

Адрес: 198099, Санкт-Петербург,
Промышленная ул, дом № 19, литера Н,
помещение 100-Н Офис 331