

High Power PIN Diode 50 MHz - 2 GHz

Rev. V1

Features

- >125 W CW Incident Power Handling @ 1 GHz
- <0.2 dB Insertion Loss @ 1 GHz
- >15 dB Isolation @ 1 GHz
- Lead-Free 3 mm 16-lead HQFN Package
- Halogen-Free “Green” Mold Compound
- RoHS* Compliant and 260°C Reflow Compatible

Description

The MADP-011037 is a high power PIN diode assembled in a lead-free 3 mm 16-lead HQFN plastic package. This series device provides exceptional switch or attenuator performance from 50 MHz to 2 GHz.

This compact device is ideally suitable for higher power switch and attenuator applications from HF through L band, where higher peak and CW power, lower loss, and higher linearity performance surface mount diode assemblies are required.

Functional Schematic

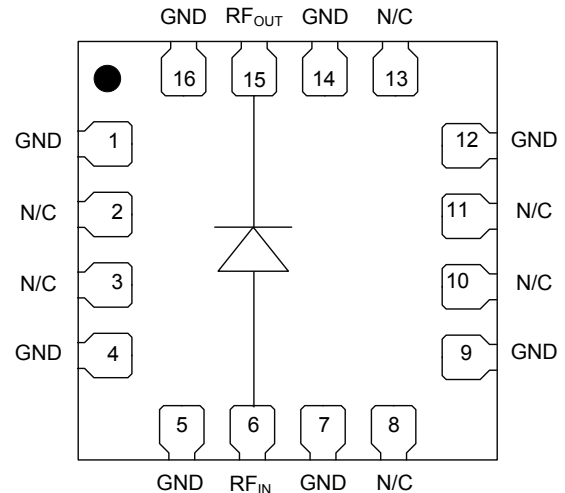

Pin Configuration³

Pin No.	Pin Name	Description
1	GND	Ground
2	N/C	Connect to Ground
3	N/C	Connect to Ground
4	GND	Ground
5	GND	Ground
6	RF _{IN}	Anode
7	GND	Ground
8	N/C	Connect to Ground
9	GND	Ground
10	N/C	Connect to Ground
11	N/C	Connect to Ground
12	GND	Ground
13	N/C	Connect to Ground
14	GND	Ground
15	RF _{OUT}	Cathode
16	GND	Ground
17	Paddle ⁴	Ground

Ordering Information^{1,2}

Part Number	Package
MADP-011037-13900T	3000 piece reel
MADP-011037-000SMB	Sample Board

1. Reference Application Note M513 for reel size information.
2. All sample boards include 5 loose parts.

*Restrictions on Hazardous Substances,
European Union Directive 2011/65/EU.

3. MACOM recommends connecting unused package pins to ground.
4. The exposed pad centered on the package bottom must be connected to RF, DC and thermal ground.

High Power PIN Diode 50 MHz - 2 GHz

Rev. V1

Electrical Specifications: Freq. = 1250 MHz, T_A = 25°C, Z₀ = 50 Ω (unless otherwise noted)

Parameter	Test Conditions	Units	Min.	Typ.	Max.
Insertion Loss	I _F = 10 mA I _F = 25 mA I _F = 50 mA	dB	—	0.17 0.13 0.11	— 0.3 —
Input Return Loss	I _F = 10 mA I _F = 25 mA I _F = 50 mA	dB	—	22 22 22	—
Isolation	V _R = 0 V V _R = 20 V V _R = 50 V	dB	— 12 —	14 14 14	—
CW Incident Power	1 GHz, CW @ +50 mA	dBm	—	52	—
Minority Carrier Lifetime	+I _F = 10 mA / I _R = -6 mA (50% Control Voltage, 90% Output Voltage)	μs	—	1.0	—
CW Thermal Resistance (Θ _{JC})	(Infinite Heat Sink at Thermal Ground Plane) I High = 4 A, I low = 10 mA @ 10 kHz	°C/W	—	30	—
Power Dissipation	(Infinite Heat Sink at Thermal Ground Plane) +I _F = 50 mA @ 1 GHz	W	—	5	—
Forward Voltage	+50 mA DC	V	—	0.9	—
Total Capacitance	-50 V @ 1 GHz	pF	—	0.30	—
Reverse Leakage Current	-200 V	nA	—	-20	—

Absolute Maximum Ratings^{5,6}

Parameter	Absolute Maximum
CW Incident Power ⁷ +50 mA, 1 GHz @ +85°C	+51 dBm
DC Forward Voltage +250 mA	1.2 V
DC Forward Current	250 mA
DC Reverse Voltage	-400V
Junction Temperature ^{8,9}	+175°C
Operating Temperature	-65°C to +125°C
Storage Temperature	-65°C to +150°C

5. Exceeding any one or combination of these limits may cause permanent damage to this device.
6. MACOM does not recommend sustained operation near these survivability limits.
7. Incident Power measured with Source and Load VSWR < 1.2:1.
8. Operating at nominal conditions with T_J ≤ +175°C will ensure MTTF > 1 x 10⁶ hours.
9. Junction Temperature (T_J) = T_A + (Θ_{JC}) * (P_D)

2

M/A-COM Technology Solutions Inc. (MACOM) and its affiliates reserve the right to make changes to the product(s) or information contained herein without notice. Visit www.macomtech.com for additional data sheets and product information.

PCB Layout

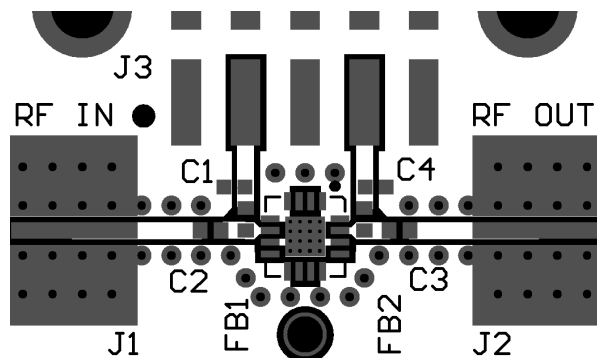

PCB Schematic

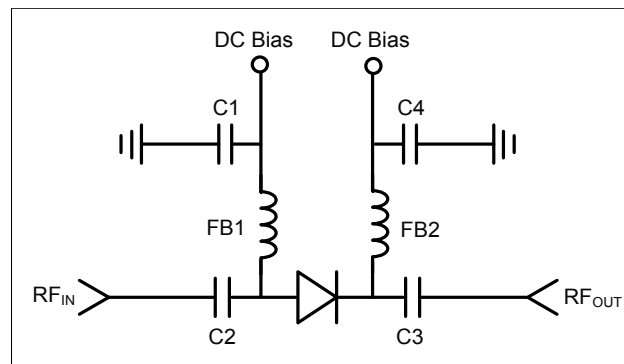

Parts List¹⁰

Part	Value	Case Style
C1, C4	62 pF	0402
C2, C3	100 pF	0402
FB1, FB2 ¹¹	470 Ω @ 1 GHz	0402

10. DC voltage with recommended components should not exceed 100 V.

11. 470 Ω resistance is included in FB1 and FB2 (recommend Murata part number BLM15GG471SN1).

Handling Procedures

Please observe the following precautions to avoid damage:

Static Sensitivity

These devices are sensitive to electrostatic discharge (ESD) and can be damaged by static electricity. Proper ESD control techniques should be used when handling these Class 2 devices.

Typical RF Small Signal Performance Curves

Insertion Loss, 10 mA Forward Bias

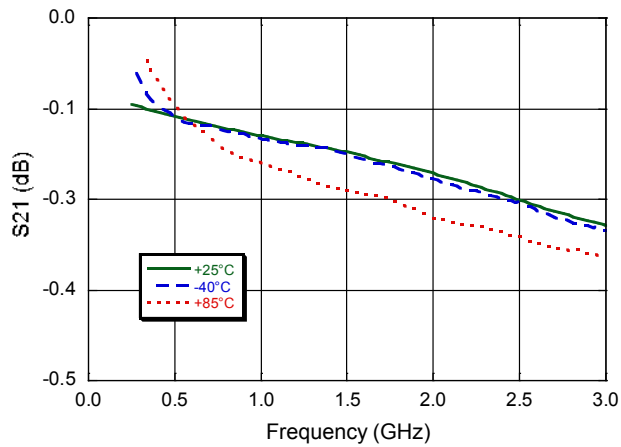

Return Loss, 10 mA Forward Bias

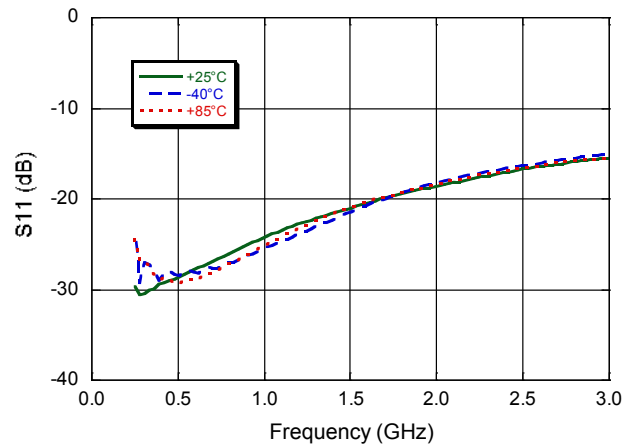

Insertion Loss, 25 mA Forward Bias

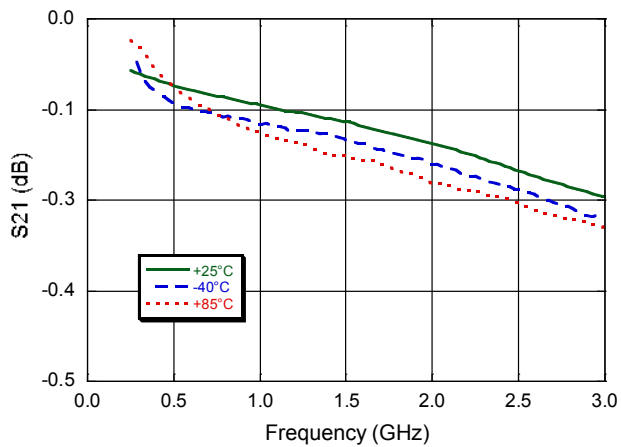

Return Loss, 25 mA Forward Bias

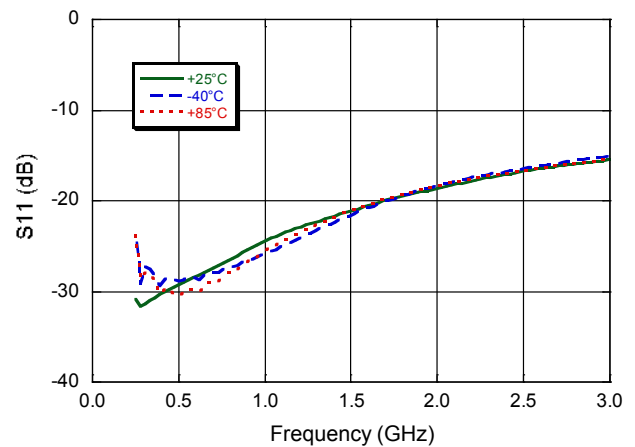

Insertion Loss, 50 mA Forward Bias

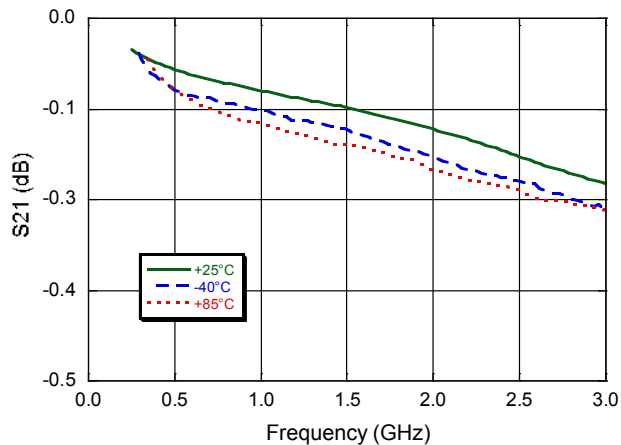

Return Loss, 50 mA Forward Bias

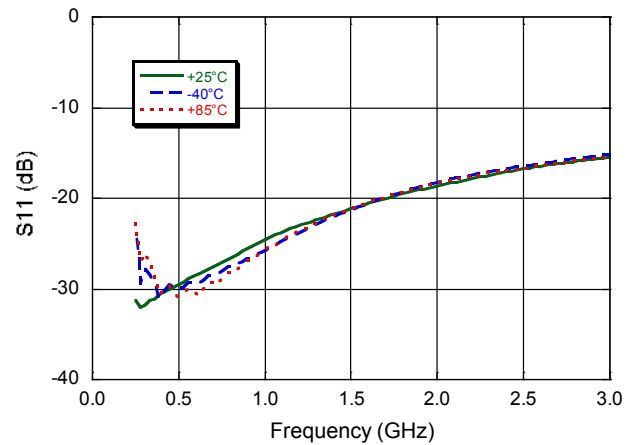

Typical RF Small Signal Performance Curves

Isolation, 0 V Reverse Bias

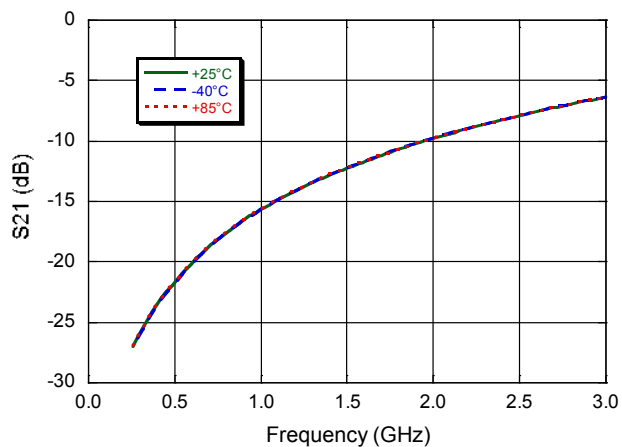

Isolation, 20 V Reverse Bias

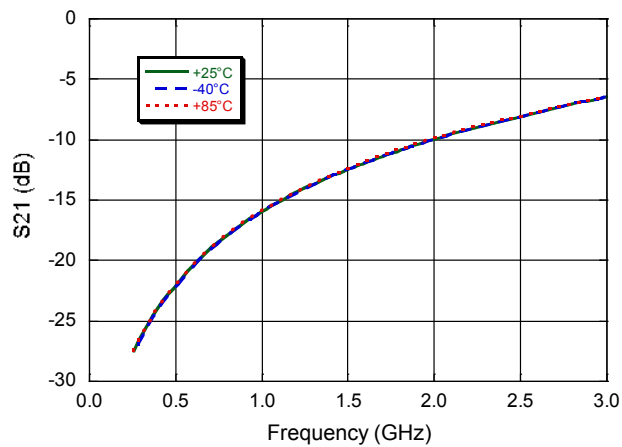

Isolation, 50 V Reverse Bias

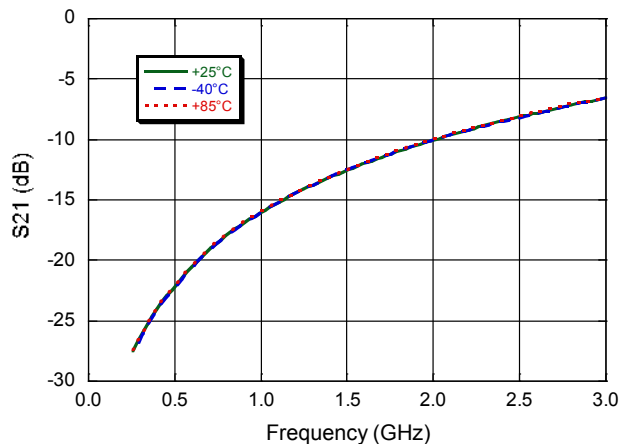

Typical High Power Performance Curves

Output Power vs. Incident Power

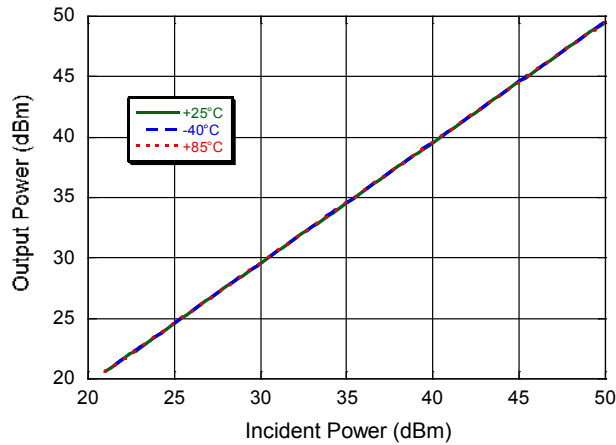

Junction Temperature 1 GHz, CW @ $T_A = +85^\circ\text{C}$

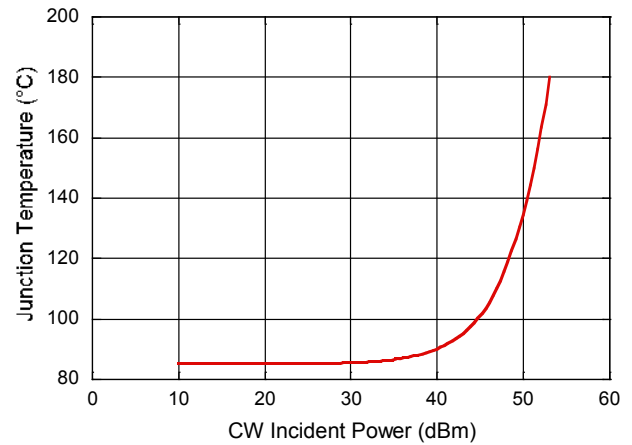

Lead-Free 3 mm 16-Lead HQFN[†]

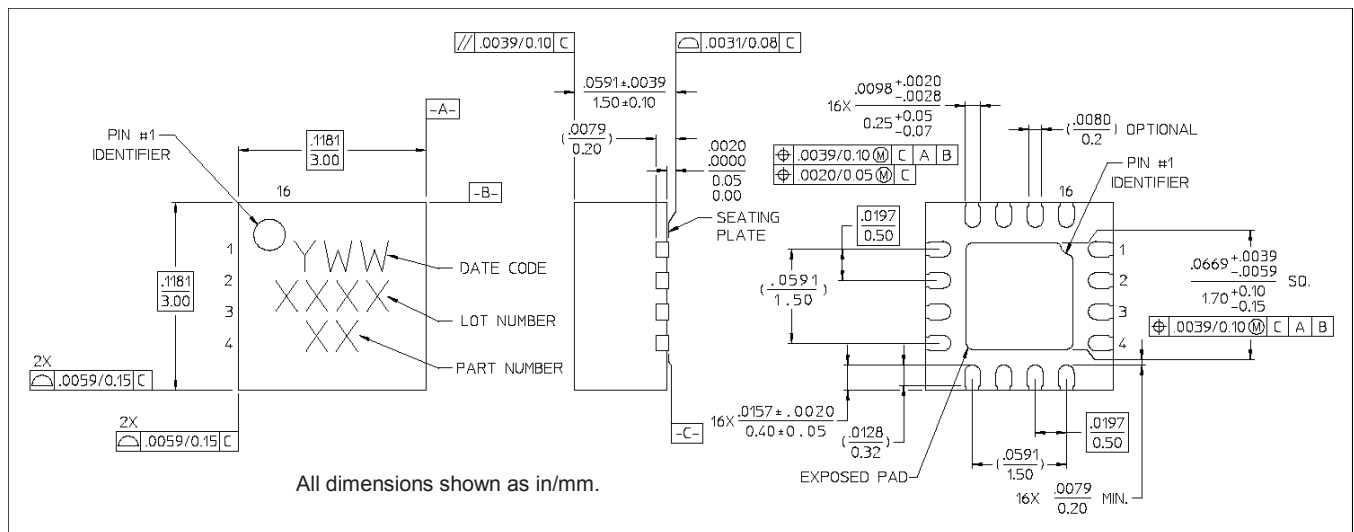

[†] Reference Application Note S2083 for lead-free solder reflow recommendations.
Meets JEDEC moisture sensitivity level 1 requirements.
Lead finish is NiPdAuAg plate.



**Стандарт
Электрон
Связь**

Мы молодая и активно развивающаяся компания в области поставок электронных компонентов. Мы поставляем электронные компоненты отечественного и импортного производства напрямую от производителей и с крупнейших складов мира.

Благодаря сотрудничеству с мировыми поставщиками мы осуществляем комплексные и плановые поставки широчайшего спектра электронных компонентов.

Собственная эффективная логистика и склад в обеспечивает надежную поставку продукции в точно указанные сроки по всей России.

Мы осуществляем техническую поддержку нашим клиентам и предпродажную проверку качества продукции. На все поставляемые продукты мы предоставляем гарантию .

Осуществляем поставки продукции под контролем ВП МО РФ на предприятия военно-промышленного комплекса России , а также работаем в рамках 275 ФЗ с открытием отдельных счетов в уполномоченном банке. Система менеджмента качества компании соответствует требованиям ГОСТ ISO 9001.

Минимальные сроки поставки, гибкие цены, неограниченный ассортимент и индивидуальный подход к клиентам являются основой для выстраивания долгосрочного и эффективного сотрудничества с предприятиями радиоэлектронной промышленности, предприятиями ВПК и научно-исследовательскими институтами России.

С нами вы становитесь еще успешнее!

Наши контакты:

Телефон: +7 812 627 14 35

Электронная почта: sales@st-electron.ru

Адрес: 198099, Санкт-Петербург,
Промышленная ул, дом № 19, литера Н,
помещение 100-Н Офис 331