

## 0.5 A Output Current IGBT and MOSFET Driver

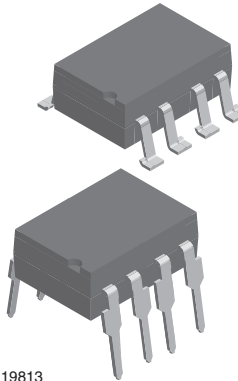

19813

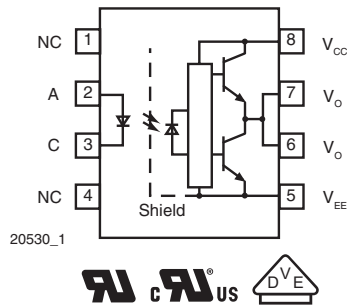

### FEATURES

- 0.5 A minimum peak output current
- 25 kV/ $\mu$ s minimum common mode rejection (CMR) at  $V_{CM} = 1500$  V
- $I_{CC} = 2.5$  mA maximum supply current
- Under voltage lock-out (UVLO) with hysteresis
- Wide operating  $V_{CC}$  range: 15 V to 32 V
- 0.4  $\mu$ s maximum propagation delay
- Industrial temperature range: - 40 °C to 110 °C
- 0.5 V maximum low level output voltage ( $V_{OL}$ )
- Compliant to RoHS directive 2002/95/EC

**RoHS**  
COMPLIANT

### DESCRIPTION

The VO3150A consists of a LED optically coupled to an integrated circuit with a power output stage. This optocoupler is ideally suited for driving power IGBTs and MOSFETs used in motor control inverter applications. The high operating voltage range of the output stage provides the drive voltages required by gate controlled devices. The voltage and current supplied by this optocoupler makes it ideally suited for directly driving IGBTs with ratings up to 800 V/20 A. For IGBTs with higher ratings, the VO3150A can be used to drive a discrete power stage which drives the IGBT gate.

### APPLICATIONS

- Isolated IGBT/MOSFET gate driver
- AC and brushless DC motor drives
- Induction stove top
- Industrial inverters
- Switch mode power supplies (SMPS)
- Uninterruptible power supplies (UPS)

### AGENCY APPROVALS

- UL - file no. E52744 system code H, double protection
- cUL - file no. E52744, equivalent to CSA bulletin 5A
- DIN EN 60747-5-5 (VDE0884) available with option 1

### ORDERING INFORMATION

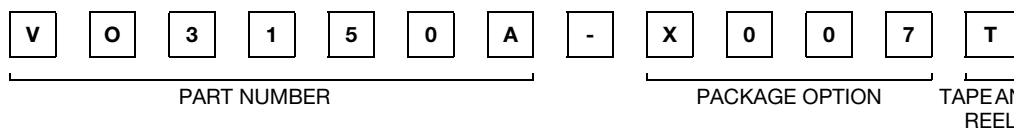

PACKAGE	UL, cUL	UL, cUL, VDE
DIP-8	VO3150A	-
SMD-8, option 7	VO3150A-X007T	VO3150A-X017T

### TRUTH TABLE

LED	$V_{CC} - V_{EE}$ "POSITIVE GOING" (TURN ON)	$V_{CC} - V_{EE}$ "NEGATIVE GOING" (TURN OFF)	$V_o$
Off	0 V to 32 V	0 V to 32 V	Low
On	0 V to 11 V	0 V to 9.5 V	Low
On	11 V to 13.5 V	9.5 V to 12 V	Transition
On	13.5 V to 32 V	12 V to 32 V	High



<b>ABSOLUTE MAXIMUM RATINGS</b> <sup>(1)</sup> ( $T_{amb} = 25\text{ }^{\circ}\text{C}$ , unless otherwise specified)				
PARAMETER	TEST CONDITION	SYMBOL	VALUE	UNIT
<b>INPUT</b>				
Input forward current		$I_F$	25	mA
Peak transient input current	< 1 $\mu\text{s}$ pulse width, 300 pps	$I_{F(TRAN)}$	1	A
Reverse input voltage		$V_R$	5	V
Output power dissipation		$P_{diss}$	45	mW
<b>OUTPUT</b>				
High peak output current <sup>(2)</sup>		$I_{OH(PEAK)}$	0.5	A
Low peak output current <sup>(2)</sup>		$I_{OL(PEAK)}$	0.5	A
Supply voltage		$(V_{CC} - V_{EE})$	0 to + 35	V
Output voltage		$V_{O(PEAK)}$	0 to + $V_{CC}$	V
Output power dissipation		$P_{diss}$	250	mW
<b>OPTOCOUPLER</b>				
Isolation test voltage (between emitter and detector, climate per DIN 500414, part 2, Nov. 74)	$t = 1\text{ s}$	$V_{ISO}$	5300	$V_{RMS}$
Storage temperature range		$T_S$	- 55 to + 125	$^{\circ}\text{C}$
Ambient operating temperature range		$T_{amb}$	- 40 to + 110	$^{\circ}\text{C}$
Total power dissipation		$P_{tot}$	295	mW
Lead solder temperature <sup>(3)</sup>	for 10 s, 1.6 mm below seating plane	$T_{sld}$	260	$^{\circ}\text{C}$

**Notes**

- <sup>(1)</sup> Stresses in excess of the absolute maximum ratings can cause permanent damage to the device. Functional operation of the device is not implied at these or any other conditions in excess of those given in the operational sections of this document. Exposure to absolute maximum ratings for extended periods of the time can adversely affect reliability.
- <sup>(2)</sup> Maximum pulse width = 10  $\mu\text{s}$ , maximum duty cycle = 0.2 %. This value is intended to allow for component tolerances for designs with  $I_O$  peak minimum = 0.5 A. See applications section for additional details on limiting  $I_{OH}$  peak.
- <sup>(3)</sup> Refer to reflow profile for soldering conditions for surface mounted devices (SMD). Refer to wave profile for soldering conditions for through hole devices (DIP).

<b>RECOMMENDED OPERATING CONDITION</b>				
PARAMETER	SYMBOL	MIN.	MAX.	UNIT
Power supply voltage	$V_{CC} - V_{EE}$	15	32	V
Input LED current (on)	$I_F$	7	16	mA
Input voltage (off)	$V_{F(OFF)}$	- 3	0.8	V
Operating temperature	$T_{amb}$	- 40	+ 110	$^{\circ}\text{C}$

<b>THERMAL CHARACTERISTICS</b>			
PARAMETER	SYMBOL	VALUE	UNIT
LED power dissipation	$P_{diss}$	45	mW
Output power dissipation	$P_{diss}$	250	mW
Total power dissipation	$P_{tot}$	285	mW
Maximum LED junction temperature	$T_{Jmax}$	125	°C
Maximum output die junction temperature	$T_{Jmax}$	125	°C
Thermal resistance, junction emitter to board	$\theta_{JEB}$	169	°C/W
Thermal resistance, junction emitter to case	$\theta_{JEC}$	192	°C/W
Thermal resistance, junction detector to board	$\theta_{JDB}$	82	°C/W
Thermal resistance, junction detector to case	$\theta_{JDC}$	80	°C/W
Thermal resistance, junction emitter to junction detector	$\theta_{JED}$	200	°C/W
Thermal resistance, case to ambient	$\theta_{CA}$	2645	°C/W

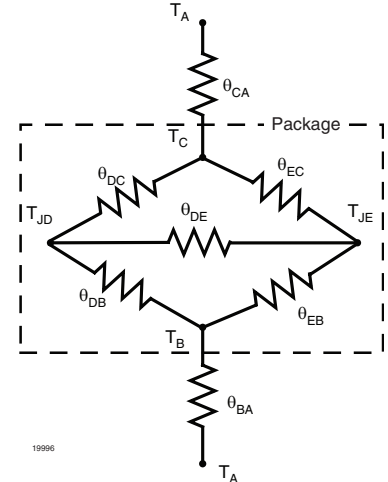
**Note**

- The thermal model is represented in the thermal network below. Each resistance value given in this model can be used to calculate the temperatures at each node for a given operating condition. The thermal resistance from board to ambient will be dependent on the type of PCB, layout and thickness of copper traces. For a detailed explanation of the thermal model, please reference Vishay's Thermal Characteristics of Optocouplers application note.

<b>ELECTRICAL CHARACTERISTICS (1)</b>						
PARAMETER	TEST CONDITION	SYMBOL	MIN.	TYP.	MAX.	UNIT
High level output current	$I_F = 16 \text{ mA}$ , $R_g = 10 \ \Omega$ , $C_g = 20 \text{ nF}$ , $V_{CC} = 15 \text{ V}$ , $V_{EE} = 0 \text{ V}$	$I_{OH}^{(3)}$	0.5			A
Low level output current	$I_F = 0 \text{ mA}$ , $R_g = 10 \ \Omega$ , $C_g = 20 \text{ nF}$ , $V_{CC} = 15 \text{ V}$ , $V_{EE} = 0 \text{ V}$	$I_{OL}^{(3)}$	0.5			A
High level output voltage	$I_O = -100 \text{ mA}$	$V_{OH}^{(4)}$	$V_{CC} - 4$	$V_{CC} - 2.1$		V
Low level output voltage	$I_O = 100 \text{ mA}$	$V_{OL}$		0.2	0.5	V
High level supply current	Output open, $I_F = 7 \text{ mA to } 16 \text{ mA}$	$I_{CCH}$			2.5	mA
Low level supply current	Output open, $V_F = -3 \text{ V to } +0.8 \text{ V}$	$I_{CCL}$			2.5	mA
Threshold input current low to high	$I_O = 0 \text{ mA}$ , $V_O > 5 \text{ V}$	$I_{FLH}$		2.1	5	mA
Threshold input voltage high to low		$V_{FHL}$	0.8			V
Input forward voltage	$I_F = 10 \text{ mA}$	$V_F$	1	1.3	1.6	V
Temperature coefficient of forward voltage	$I_F = 10 \text{ mA}$	$\Delta V_F / \Delta T_A$		-1.4		mV/°C
Input reverse breakdown voltage	$I_R = 10 \ \mu\text{A}$	BVP	5			V
Input capacitance	$f = 1 \text{ MHz}$ , $V_F = 0 \text{ V}$	$C_{IN}$		60		pF
UVLO threshold	$V_O \geq 5 \text{ V}$	$V_{UVLO+}$	11	12.6	13.5	V
	$I_F = 10 \text{ mA}$	$V_{UVLO-}$	9.5	10.7	12	V
UVLO hysteresis		$UVLO_{HYS}$		1.9		V

**Notes**

- Minimum and maximum values were tested over recommended operating conditions ( $T_{amb} = -40 \text{ °C to } 110 \text{ °C}$ ,  $I_{F(ON)} = 7 \text{ mA to } 16 \text{ mA}$ ,  $V_{F(OFF)} = -3 \text{ V to } 0.8 \text{ V}$ ,  $V_{CC} = 15 \text{ V to } 32 \text{ V}$ ,  $V_{EE} = \text{ground}$ ) unless otherwise specified. Typical values are characteristics of the device and are the result of engineering evaluations. Typical values are for information only and are not part of the testing requirements. All typical values were measured at  $T_{amb} = 25 \text{ °C}$  and with  $V_{CC} - V_{EE} = 32 \text{ V}$ .
- Maximum pulse width = 50  $\mu\text{s}$ , maximum duty cycle = 0.5 %.
- Maximum pulse width = 10  $\mu\text{s}$ , maximum duty cycle = 0.2 %. This value is intended to allow for component tolerances for designs with  $I_O$  peak minimum = 0.5 A.
- In this test  $V_{OH}$  is measured with a dc load current. When driving capacitive loads  $V_{OH}$  will approach  $V_{CC}$  as  $I_{OH}$  approaches zero A. Maximum pulse width = 1 ms, maximum duty cycle = 20 %.

## TEST CIRCUITS

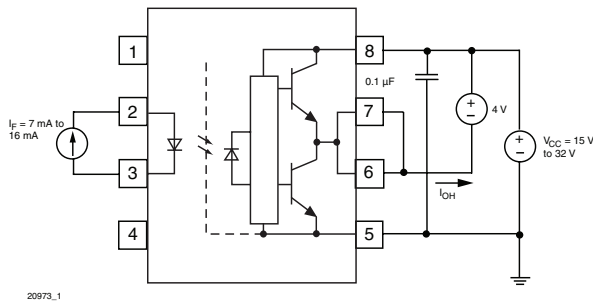

Fig. 1 -  $I_{OH}$  Test Circuit

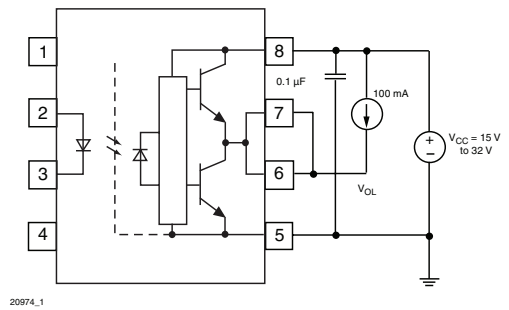

Fig. 4 -  $V_{OL}$  Test Circuit

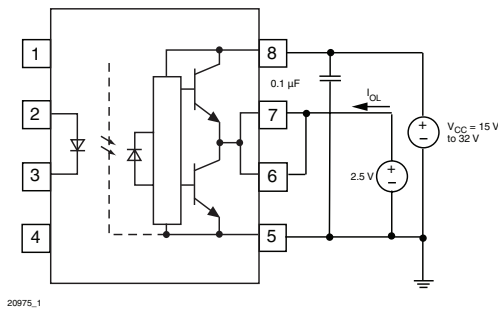

Fig. 2 -  $I_{OL}$  Test Circuit

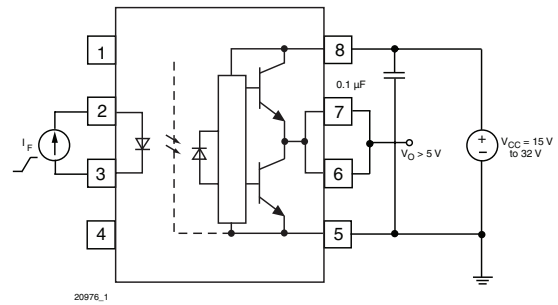

Fig. 5 -  $I_{FLH}$  Test Circuit

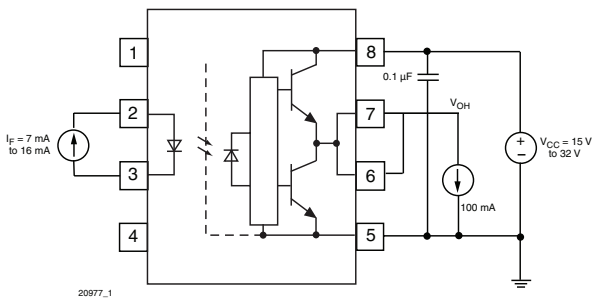

Fig. 3 -  $V_{OH}$  Test Circuit

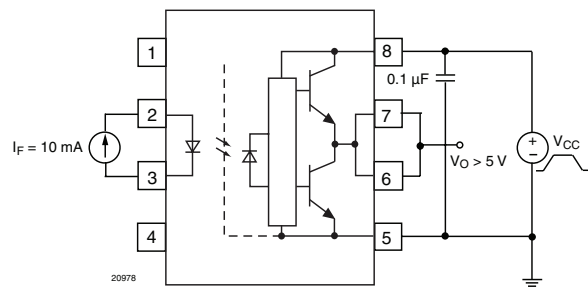

Fig. 6 - UVLO Test Circuit

SWITCHING CHARACTERISTICS						
PARAMETER	TEST CONDITION	SYMBOL	MIN.	TYP.	MAX.	UNIT
Propagation delay time to logic low output <sup>(1)</sup>	$R_g = 47 \Omega$ , $C_g = 3 \text{ nF}$ , $f = 10 \text{ kHz}$ , duty cycle = 50 %	$t_{PHL}$	0.1		0.4	$\mu\text{s}$
Propagation delay time to logic high output <sup>(1)</sup>	$R_g = 47 \Omega$ , $C_g = 3 \text{ nF}$ , $f = 10 \text{ kHz}$ , duty cycle = 50 %	$t_{PLH}$	0.1		0.4	$\mu\text{s}$
Pulse width distortion <sup>(2)</sup>	$R_g = 47 \Omega$ , $C_g = 3 \text{ nF}$ , $f = 10 \text{ kHz}$ , duty cycle = 50 %	PWD			0.2	$\mu\text{s}$
Propagation delay difference between any two parts <sup>(3)</sup>	$R_g = 47 \Omega$ , $C_g = 3 \text{ nF}$ , $f = 10 \text{ kHz}$ , duty cycle = 50 %	PDD ( $t_{PHL} - t_{PLH}$ )	- 0.35		0.35	$\mu\text{s}$
Rise time	$R_g = 47 \Omega$ , $C_g = 3 \text{ nF}$ , $f = 10 \text{ kHz}$ , duty cycle = 50 %	$t_r$		0.1		$\mu\text{s}$
Fall time	$R_g = 47 \Omega$ , $C_g = 3 \text{ nF}$ , $f = 10 \text{ kHz}$ , duty cycle = 50 %	$t_f$		0.1		$\mu\text{s}$

**SWITCHING CHARACTERISTICS**

PARAMETER	TEST CONDITION	SYMBOL	MIN.	TYP.	MAX.	UNIT
UVLO turn on delay	$V_O > 5\text{ V}$ , $I_F = 10\text{ mA}$	$T_{UVLO-ON}$		0.8		$\mu\text{s}$
UVLO turn off delay	$V_O > 5\text{ V}$ , $I_F = 10\text{ mA}$	$T_{UVLO-OFF}$		0.6		$\mu\text{s}$

**Notes**

- (1) This load condition approximates the gate load of a 1200 V/25 A IGBT.
- (2) Pulse width distortion (PWD) is defined as  $|t_{pHL} - t_{pLH}|$  for any given device.
- (3) The difference between  $t_{pHL}$  and  $t_{pLH}$  between any two VO3150A parts under the same test condition.

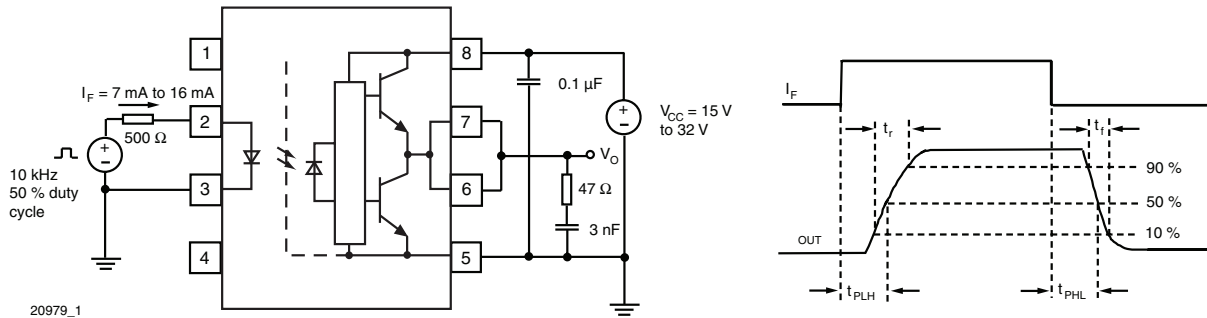
 Fig. 7 -  $t_{pLH}$ ,  $t_{pHL}$ ,  $t_r$  and  $t_f$  Test Circuit and Waveforms

**COMMON MODE TRANSIENT IMMUNITY**

PARAMETER	TEST CONDITION	SYMBOL	MIN.	TYP.	MAX.	UNIT
Common mode transient immunity at logic high output <sup>(1)(2)</sup>	$T_A = 25\text{ }^\circ\text{C}$ , $I_F = 10\text{ mA to }16\text{ mA}$ , $V_{CM} = 1500\text{ V}$ , $V_{CC} = 32\text{ V}$	$ CM_H $	25	35		$\text{kV}/\mu\text{s}$
Common mode transient immunity at logic low output <sup>(1)(3)</sup>	$T_A = 25\text{ }^\circ\text{C}$ , $V_{CM} = 1500\text{ V}$ , $V_{CC} = 32\text{ V}$ , $V_F = 0\text{ V}$	$ CM_L $	25	35		$\text{kV}/\mu\text{s}$

**Notes**

- (1) Pins 1 and 4 need to be connected to LED common.
- (2) Common mode transient immunity in the high state is the maximum tolerable  $|dV_{CM}/dt|$  of the common mode pulse,  $V_{CM}$ , to assure that the output will remain in the high state (i.e.,  $V_O > 15\text{ V}$ ).
- (3) Common mode transient immunity in a low state is the maximum tolerable  $|dV_{CM}/dt|$  of the common mode pulse,  $V_{CM}$ , to assure that the output will remain in a low state (i.e.,  $V_O < 1\text{ V}$ ).

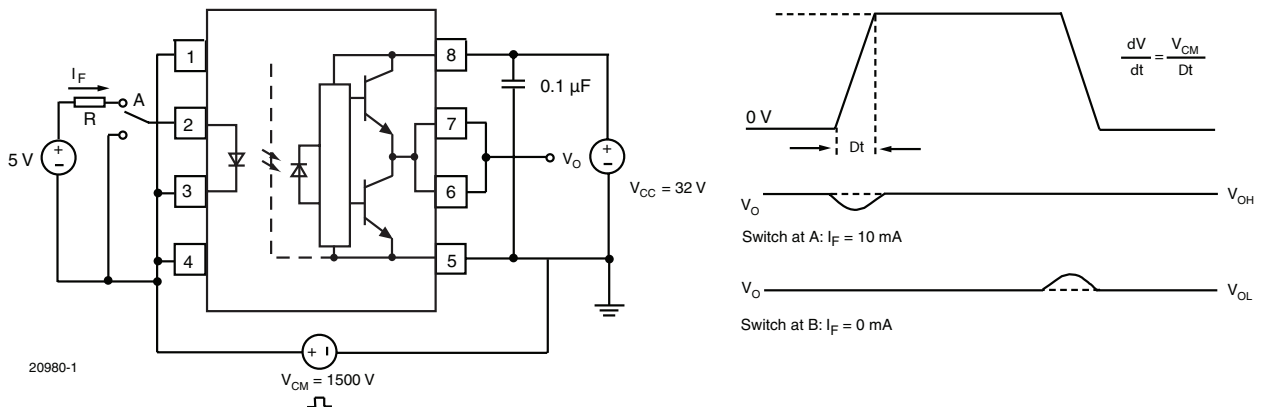

Fig. 8 - CMR Test Circuit and Waveforms

SAFETY AND INSULATION RATINGS						
PARAMETER	TEST CONDITION	SYMBOL	MIN.	TYP.	MAX.	UNIT
Climatic classification (according to IEC 68 part 1)				40/110/21		
Comparative tracking index		CTI	175		399	
$V_{IOTM}$			8000			V
$V_{IORM}$			890			V
$P_{SO}$					500	mW
$I_{SI}$					300	mA
$T_{SI}$					175	°C
Creepage distance	Standard DIP-8		7			mm
Clearance distance	Standard DIP-8		7			mm
Creepage distance	400 mil DIP-8		8			mm
Clearance distance	400 mil DIP-8		8			mm

**Note**

- As per IEC 60747-5-5, §7.4.3.8.1, this optocoupler is suitable for “safe electrical insulation” only within the safety ratings. Compliance with the safety ratings shall be ensured by means of protective circuits.

**TYPICAL CHARACTERISTICS** ( $T_{amb} = 25\text{ }^{\circ}\text{C}$ , unless otherwise specified)

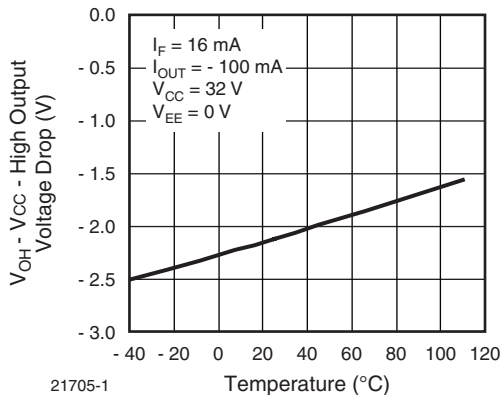

21705-1  
Fig. 9 - High Output Voltage Drop vs. Temperature

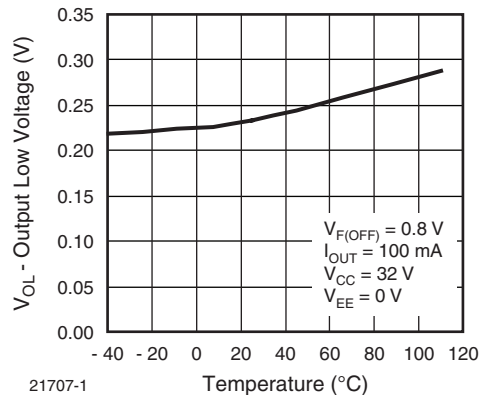

21707-1  
Fig. 11 - Output Low Voltage vs. Temperature

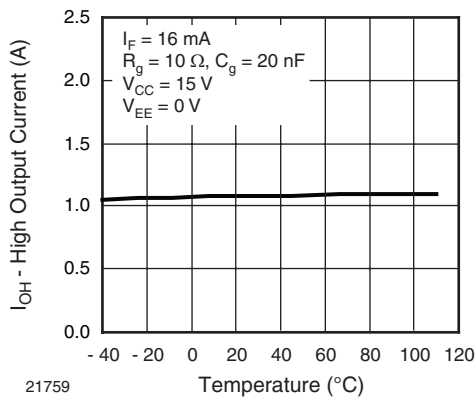

21759  
Fig. 10 - High Output Current vs. Temperature

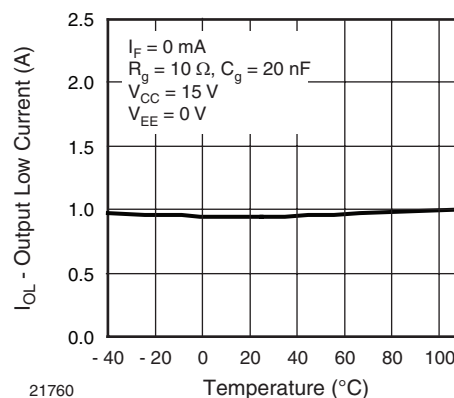

21760  
Fig. 12 - Output Low Current vs. Temperature

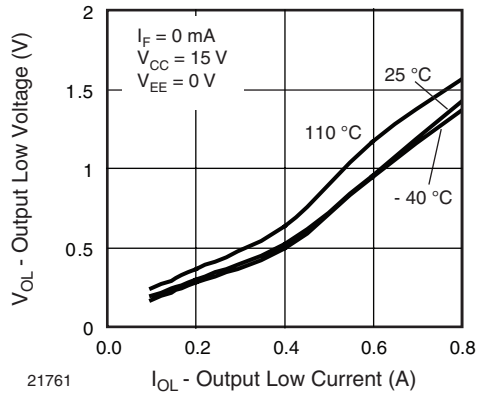

Fig. 13 - Output Low Voltage vs. Output Low Current

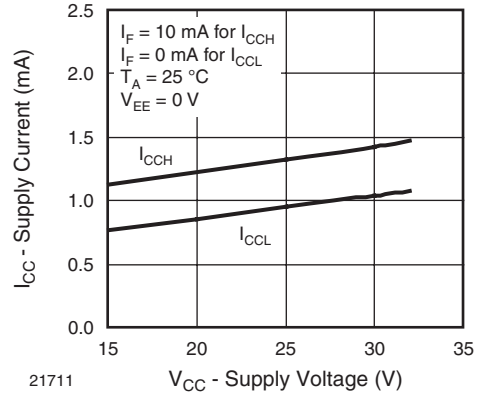

Fig. 16 - Supply Current vs. Supply Voltage

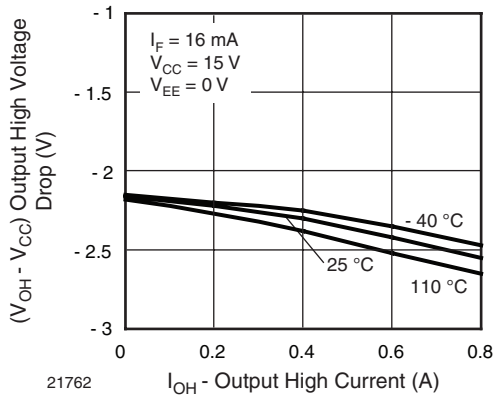

Fig. 14 - Output High Voltage Drop vs. Output High Current

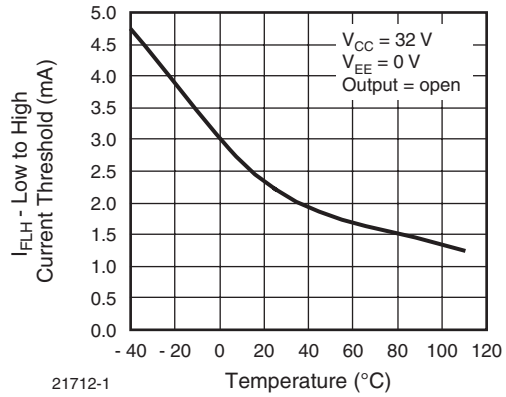

Fig. 17 - Low to High Current Threshold vs. Temperature

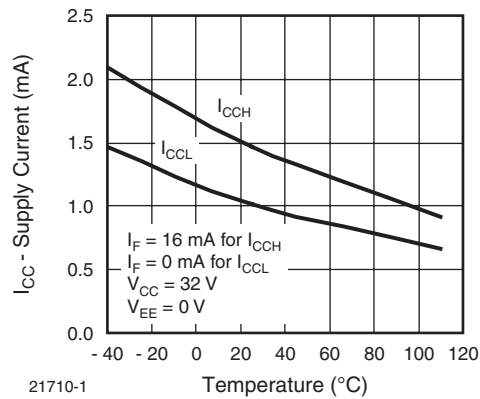

Fig. 15 - Supply Current vs. Temperature

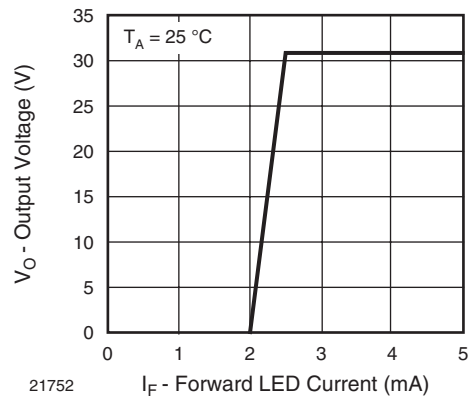

Fig. 18 - Transfer Characteristics

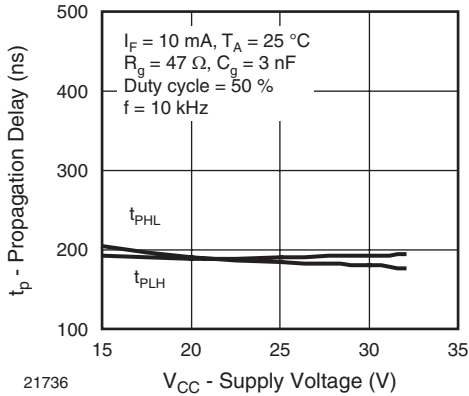

Fig. 19 - Propagation Delay vs. Supply Voltage

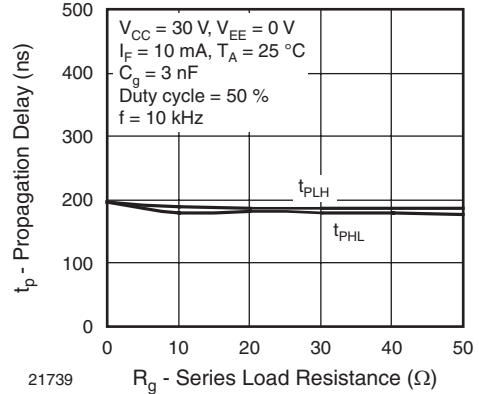

Fig. 22 - Propagation Delay vs. Series Load Resistance

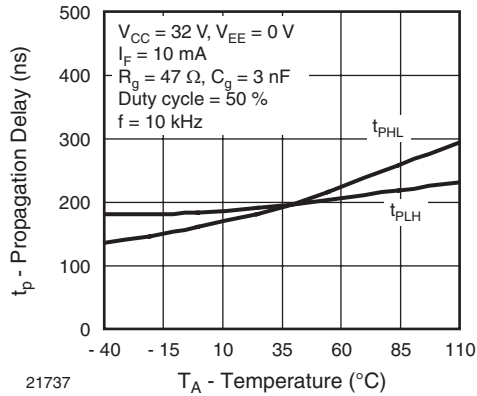

Fig. 20 - Propagation Delay vs. Temperature

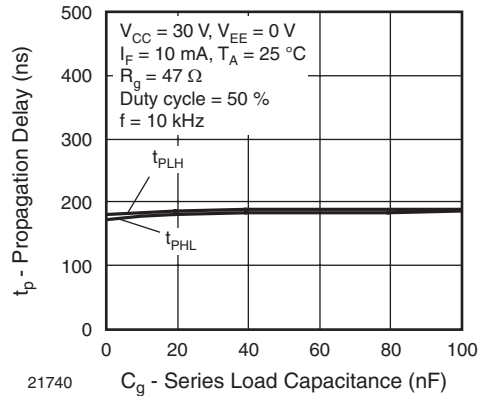

Fig. 23 - Propagation Delay vs. Series Load Capacitance

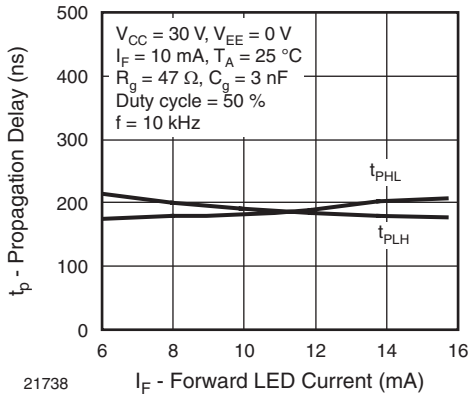
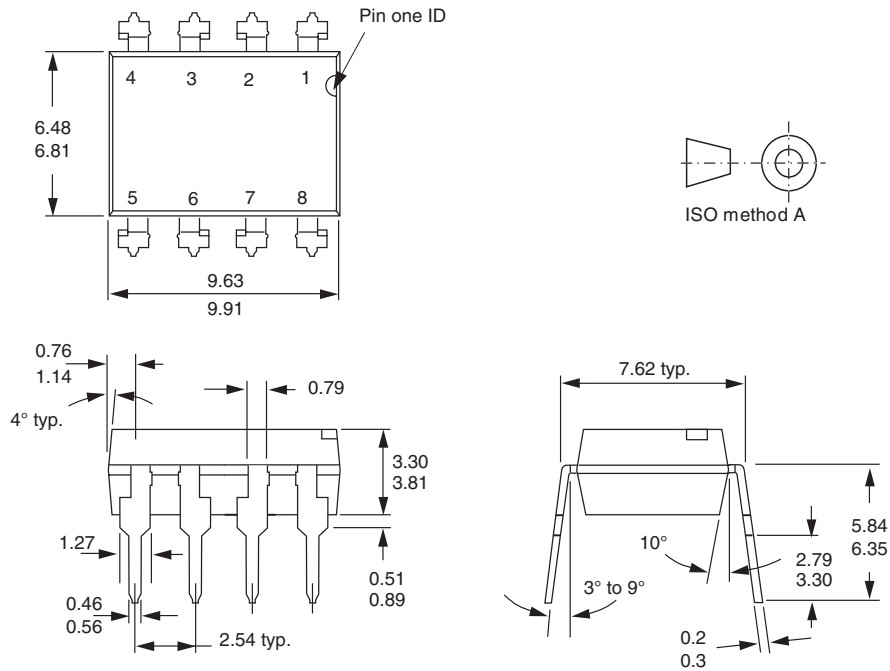
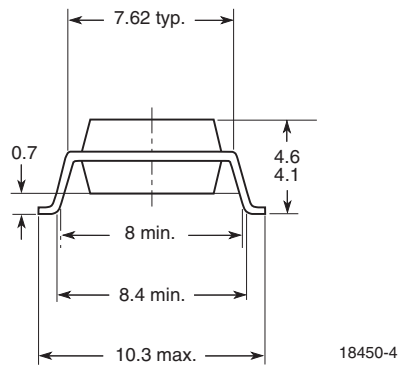
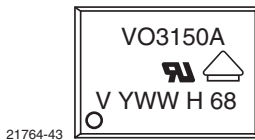

Fig. 21 - Propagation Delay vs. Forward LED Current



**PACKAGE DIMENSIONS** in millimeters

i178006

**Option 7**

**PACKAGE MARKING**

**Note**

- VDE logo is only marked on option 1 parts. Option information is not marked on the part.



## Disclaimer

ALL PRODUCT, PRODUCT SPECIFICATIONS AND DATA ARE SUBJECT TO CHANGE WITHOUT NOTICE TO IMPROVE RELIABILITY, FUNCTION OR DESIGN OR OTHERWISE.

Vishay Intertechnology, Inc., its affiliates, agents, and employees, and all persons acting on its or their behalf (collectively, "Vishay"), disclaim any and all liability for any errors, inaccuracies or incompleteness contained in any datasheet or in any other disclosure relating to any product.

Vishay makes no warranty, representation or guarantee regarding the suitability of the products for any particular purpose or the continuing production of any product. To the maximum extent permitted by applicable law, Vishay disclaims (i) any and all liability arising out of the application or use of any product, (ii) any and all liability, including without limitation special, consequential or incidental damages, and (iii) any and all implied warranties, including warranties of fitness for particular purpose, non-infringement and merchantability.

Statements regarding the suitability of products for certain types of applications are based on Vishay's knowledge of typical requirements that are often placed on Vishay products in generic applications. Such statements are not binding statements about the suitability of products for a particular application. It is the customer's responsibility to validate that a particular product with the properties described in the product specification is suitable for use in a particular application. Parameters provided in datasheets and/or specifications may vary in different applications and performance may vary over time. All operating parameters, including typical parameters, must be validated for each customer application by the customer's technical experts. Product specifications do not expand or otherwise modify Vishay's terms and conditions of purchase, including but not limited to the warranty expressed therein.

Except as expressly indicated in writing, Vishay products are not designed for use in medical, life-saving, or life-sustaining applications or for any other application in which the failure of the Vishay product could result in personal injury or death. Customers using or selling Vishay products not expressly indicated for use in such applications do so at their own risk. Please contact authorized Vishay personnel to obtain written terms and conditions regarding products designed for such applications.

No license, express or implied, by estoppel or otherwise, to any intellectual property rights is granted by this document or by any conduct of Vishay. Product names and markings noted herein may be trademarks of their respective owners.

## Material Category Policy

**Vishay Intertechnology, Inc. hereby certifies that all its products that are identified as RoHS-Compliant fulfill the definitions and restrictions defined under Directive 2011/65/EU of The European Parliament and of the Council of June 8, 2011 on the restriction of the use of certain hazardous substances in electrical and electronic equipment (EEE) - recast, unless otherwise specified as non-compliant.**

**Please note that some Vishay documentation may still make reference to RoHS Directive 2002/95/EC. We confirm that all the products identified as being compliant to Directive 2002/95/EC conform to Directive 2011/65/EU.**

**Vishay Intertechnology, Inc. hereby certifies that all its products that are identified as Halogen-Free follow Halogen-Free requirements as per JEDEC JS709A standards. Please note that some Vishay documentation may still make reference to the IEC 61249-2-21 definition. We confirm that all the products identified as being compliant to IEC 61249-2-21 conform to JEDEC JS709A standards.**



**Стандарт  
Электрон  
Связь**

Мы молодая и активно развивающаяся компания в области поставок электронных компонентов. Мы поставляем электронные компоненты отечественного и импортного производства напрямую от производителей и с крупнейших складов мира.

Благодаря сотрудничеству с мировыми поставщиками мы осуществляем комплексные и плановые поставки широчайшего спектра электронных компонентов.

Собственная эффективная логистика и склад в обеспечивает надежную поставку продукции в точно указанные сроки по всей России.

Мы осуществляем техническую поддержку нашим клиентам и предпродажную проверку качества продукции. На все поставляемые продукты мы предоставляем гарантию .

Осуществляем поставки продукции под контролем ВП МО РФ на предприятия военно-промышленного комплекса России , а также работаем в рамках 275 ФЗ с открытием отдельных счетов в уполномоченном банке. Система менеджмента качества компании соответствует требованиям ГОСТ ISO 9001.

Минимальные сроки поставки, гибкие цены, неограниченный ассортимент и индивидуальный подход к клиентам являются основой для выстраивания долгосрочного и эффективного сотрудничества с предприятиями радиоэлектронной промышленности, предприятиями ВПК и научно-исследовательскими институтами России.

С нами вы становитесь еще успешнее!

**Наши контакты:**

**Телефон:** +7 812 627 14 35

**Электронная почта:** [sales@st-electron.ru](mailto:sales@st-electron.ru)

**Адрес:** 198099, Санкт-Петербург,  
Промышленная ул, дом № 19, литера Н,  
помещение 100-Н Офис 331