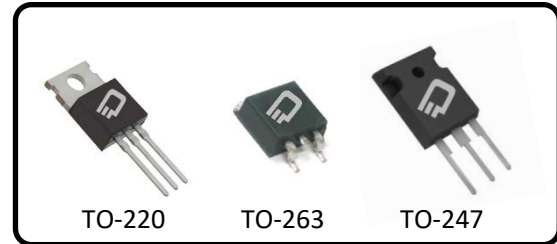


## 650V, 99mΩ, 31.8 A Super Junction Power MOSFET

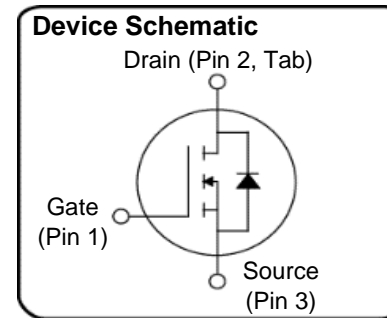
### Ordering Information

Part Number	Package Option
D3S099N65B-U	TO-220
D3S099N65D-U	TO-247
D3S099N65E-U	TO-263



### Description

+FET™ is an advanced Super Junction Power MOSFET offering excellent efficiency through low  $R_{DS-ON}$  and low gate charge. +FET™ is a rugged device with precision charge balance implementation designed for demanding uses such as enterprise power computing power supplies, motor control, lighting and other challenging power conversion applications.



### Features

- LOW  $R_{DS(ON)}$
- FAST SWITCHING
- HIGH  $E_{AS}$
- REL TEST SPEC: JESD-22
- HTRB >3000 HRS

**Table 1** Key Parameters

Parameter	Value	Unit
$V_{DSS}$ @ $T_{jmax}$	710	V
$R_{DS(on)}$ max	< 99	mΩ
$Q_g$ typ	77	nC
$I_D$ @ 25 °C	44.9	A

### Benefits

- LOW CONDUCTION LOSSES
- HIGH EFFICIENCY
- EXCELLENT AVALANCHE PERFORMANCE

### Applications

- POWER FACTOR CORRECTION
- SERVER POWER SUPPLIES
- TELECOM POWER SUPPLIES
- INVERTERS
- MOTOR CONTROL

## Contents

---

Contents.....	2
1. Maximum Ratings.....	3
2. Thermal Characteristics.....	4
3. Electrical Characteristics.....	5
4. Package Outlines.....	12
5. Revision History.....	16
6. Resources.....	16
7. Patents, Copyrights and Trademarks.....	16
8. Legal Disclaimer.....	16

## Maximum Ratings

**Table 2** Maximum Ratings

 @  $T_j = 25^\circ\text{C}$ , unless otherwise specified

Parameter	Symbol	Values			Unit	Condition
		Min	Typ	Max		
Continuous drain current	$I_D$			31.8	A	$T_C = 25^\circ\text{C}$
				23.7	A	$T_C = 100^\circ\text{C}$
Pulsed drain current	$I_{D, \text{pulse}}$			127	A	$T_C = 25^\circ\text{C}$
Avalanche energy, single pulse	$E_{AS}$			650	mJ	$I_D = 8.7\text{A}; V_{DD} = 50\text{V}, V_{GS} = 10\text{V}, L = 17\text{mH}, R_G = 25\ \Omega$
Avalanche energy, repetitive	$E_{AR}$			1.0	mJ	$I_D = 8.7\text{A}; V_{DD} = 50\text{V}$
Avalanche current, repetitive	$I_{AR}$			8.7	A	
MOSFET dv/dt ruggedness	dv/dt			50	V/ns	$V_{DS} = 0 \dots 400\text{V}$
Gate source voltage (static)	$V_{GS}$	-30		30	V	Static
Gate source voltage (dynamic)	$V_{GS}$	-30		30	V	AC ( $F > 1\text{Hz}$ )
Power dissipation	$P_{\text{tot}}$			154	W	TO-220, TO-263, TO-247, $T_C = 25^\circ\text{C}$
Storage temperature	$T_{\text{stg}}$	-55		150	$^\circ\text{C}$	
Operating junction temperature	$T_j$	-55		150	$^\circ\text{C}$	
Mounting torque				60	N-cm	
Continuous diode forward current	$I_{SD}$			31.8	A	$T_C = 25^\circ\text{C}$
Diode pulse current	$I_{S, \text{pulse}}$			127	A	$T_C = 25^\circ\text{C}$
Reverse diode dv/dt	dv/dt			15	V/ns	$V_{DS} = 0 \dots 400\text{V}, I_{SD} \leq I_S, T_j = 25^\circ\text{C}$
Maximum diode commutation speed	$di/dt$			500	A/ $\mu\text{s}$	$V_{DS} = 0 \dots 400\text{V}, I_{SD} \leq I_S, T_j = 25^\circ\text{C}$

## Thermal Characteristics

**Table 3** Thermal Characteristics

Symbol	Parameter	Values			Unit
		TO-220	TO-263	TO-247	
R <sub>thjC</sub>	Thermal resistance, junction-case	0.81	0.81	0.81	°C/W
R <sub>thjA</sub>	Thermal resistance, junction-ambient	62	62	50	°C/W
R <sub>thjT</sub>	Thermal resistance, junction-ambient for SMD version		30		°C/W
T <sub>s</sub>	Soldering temperature, wavesoldering only allowed at leads	260	260	260	°C

## Electrical Characteristics

@ T<sub>j</sub> = 25°C, unless otherwise specified

**Table 4**

Parameter	Symbol	Values			Unit	Condition
		Min	Typ	Max		
Drain-source breakdown voltage	V <sub>DSS</sub>	650			V	I <sub>D</sub> = 1mA, V <sub>GS</sub> = 0V
Gate threshold voltage	V <sub>GS(th)</sub>	2.3	3	3.7	V	
Zero gate voltage drain current	I <sub>DSS</sub>			1	μA	V <sub>DS</sub> = 650V, T <sub>C</sub> = 25°C
				50		V <sub>DS</sub> = 650V, T <sub>C</sub> = 125°C
Gate-source leakage current	I <sub>GSS</sub>			100	nA	
Drain-source on-state resistance	R <sub>DS(on)</sub>		0.062	0.099	Ω	V <sub>GS</sub> = 10V, I <sub>D</sub> = 15.9A, T <sub>C</sub> = 25°C
	R <sub>DS(on)</sub>		0.160			V <sub>GS</sub> = 10V, I <sub>D</sub> = 15.9A, T <sub>C</sub> = 150°C
Gate resistance	R <sub>G</sub>		1		Ω	

**Table 5**

Parameter	Symbol	Values			Unit	Condition
		Min	Typ	Max		
Input capacitance	C <sub>iss</sub>		4240		pF	V <sub>DS</sub> = 100V, f = 1MHz, V <sub>GS</sub> = 0V
Output capacitance	C <sub>oss</sub>		97.5		pF	
Reverse transfer capacitance	C <sub>rss</sub>		16.5		pF	
Turn-on delay time	t <sub>d(on)</sub>		17		ns	V <sub>DD</sub> = 400V, I <sub>D</sub> = 15.9A R <sub>G</sub> = 1Ω, V <sub>GS</sub> = 10V
Rise time	t <sub>r</sub>		24		ns	
Turn-off delay time	t <sub>d(off)</sub>		90		ns	
Fall time	t <sub>f</sub>		23		ns	

**Table 6** Gate Charge Characteristics

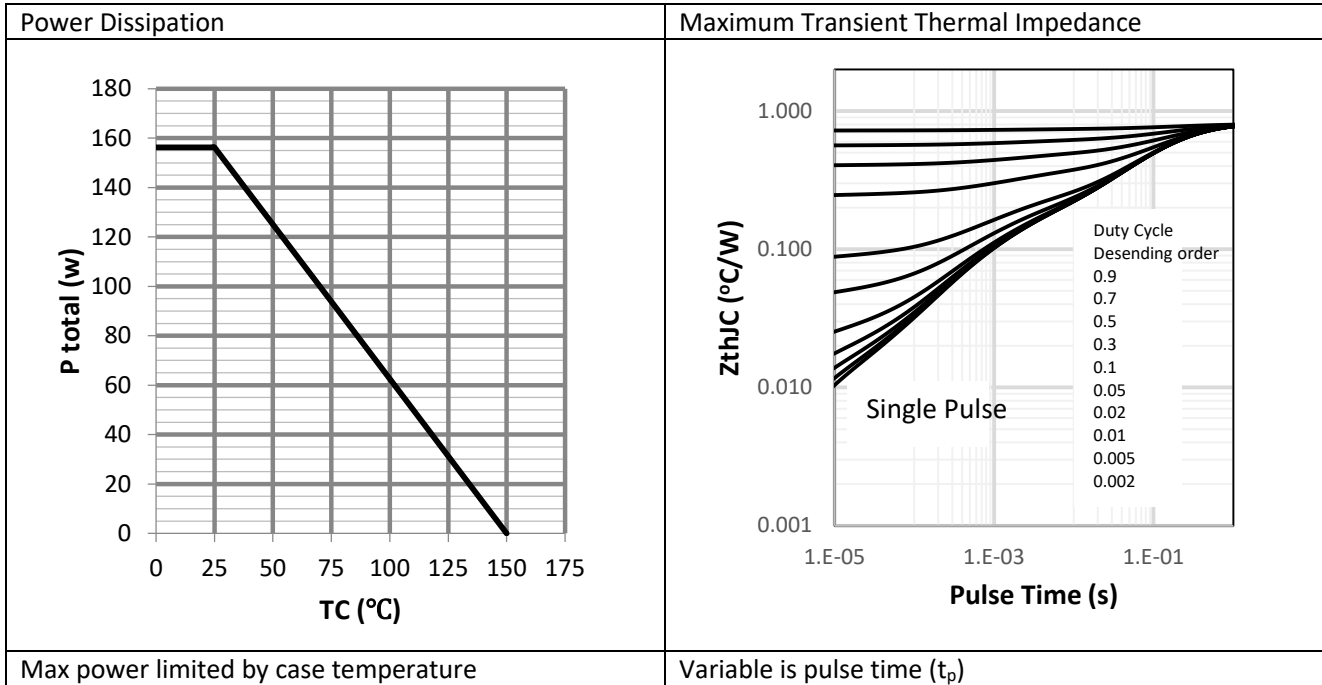
Parameter	Symbol	Values			Unit	Condition
		Min	Typ	Max		
Gate to source charge	$Q_{gs}$		16		nC	$V_{DD} = 480V, I_D = 15.5A,$ $V_{GS} = 10V$
Gate to drain charge	$Q_{gd}$		27		nC	
Gate charge total	$Q_g$		77		nC	
Gate plateau voltage	$V_{plateau}$		5		V	

**Table 7** Body Diode

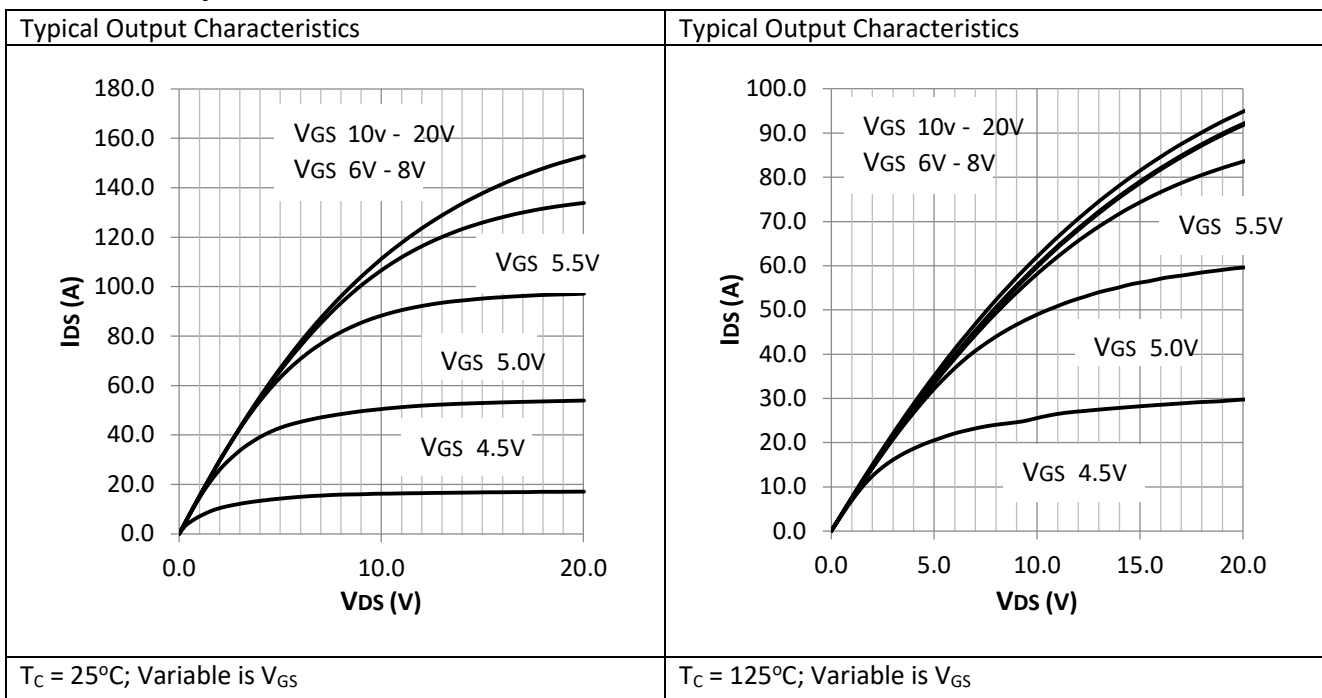
Parameter	Symbol	Values			Unit	Condition
		Min	Typ	Max		
Diode source-drain current	$I_{SD}$			38.3	A	
Diode forward voltage	$V_{fd}$		0.95	1.5	V	$I_{SD} = 31.8A, V_{GS} = 0V$
Reverse recovery time	$t_{rr}$		468		ns	$I_{SD} = 31.8A, di/dt = 100A/\mu S$ $V_{DD} = 60V, T_C = 25^\circ C$
Reverse recovery charge	$Q_{rr}$		9.5		$\mu C$	
Peak reverse recovery current	$I_{rrm}$		50.0		A	

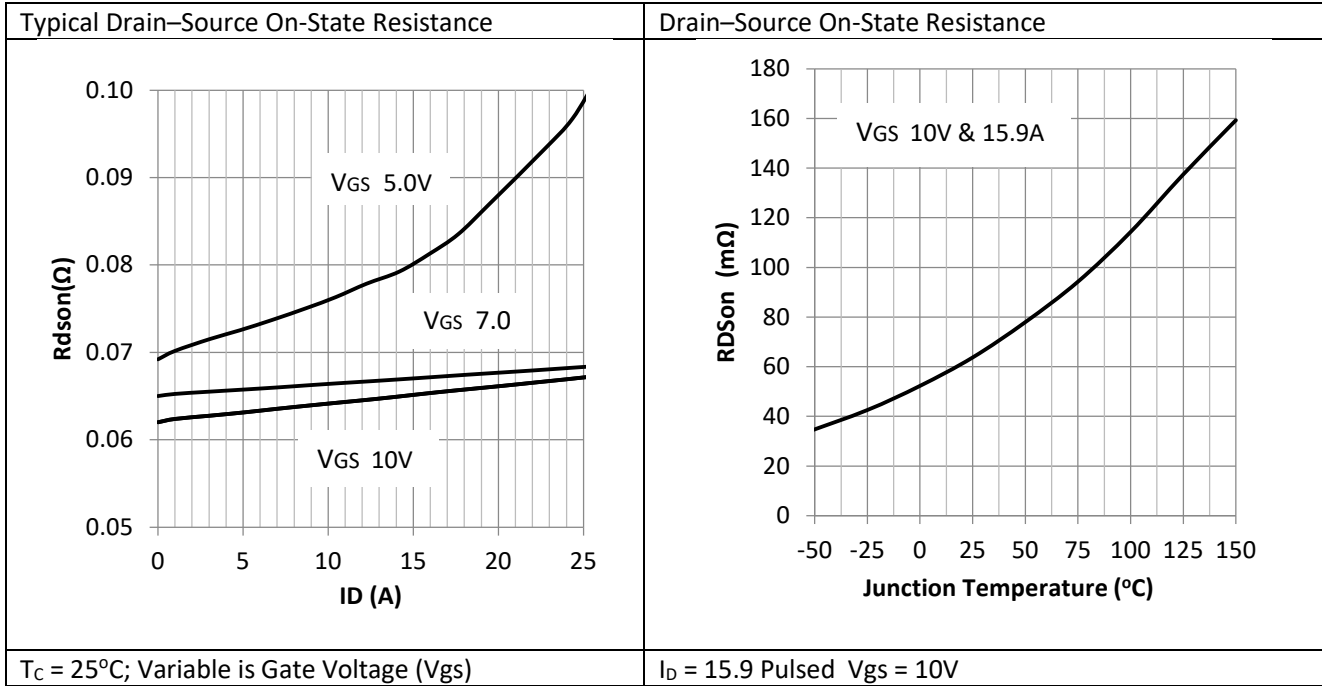
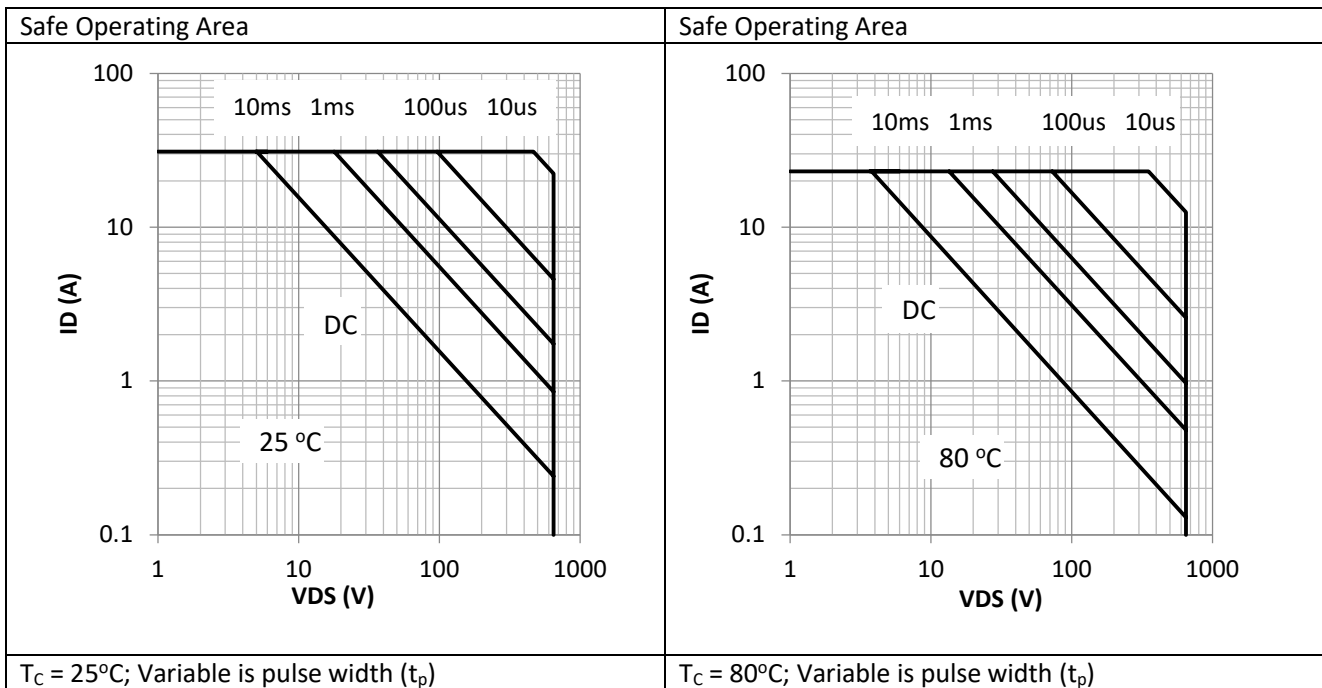
## Electrical Characteristics Graphs

**Table 8 Thermal Performance**

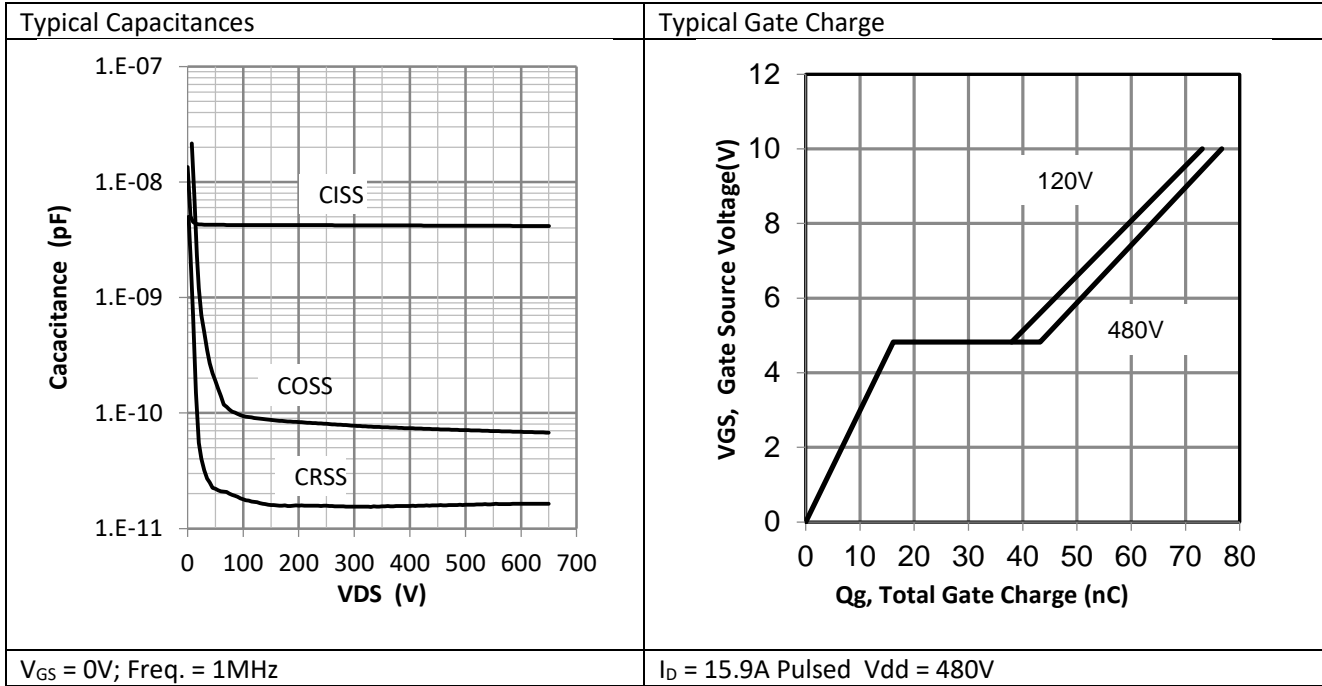
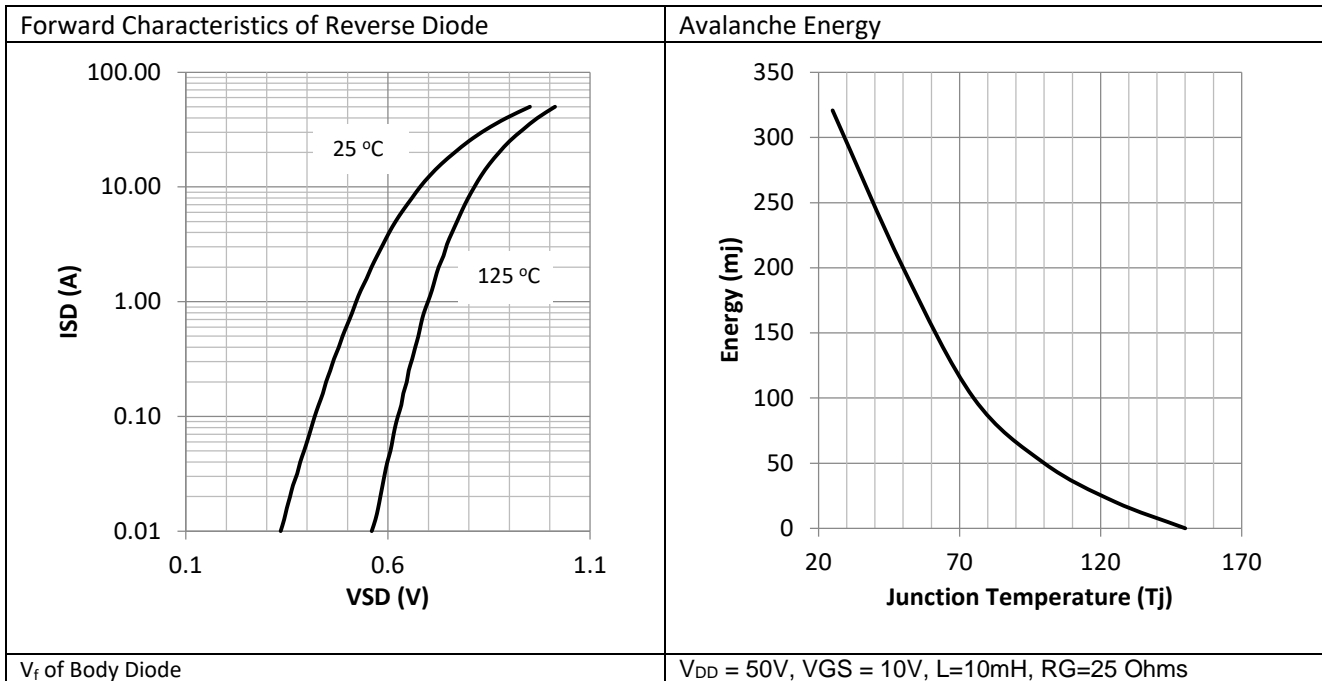


**Table 9 Output Characteristics**

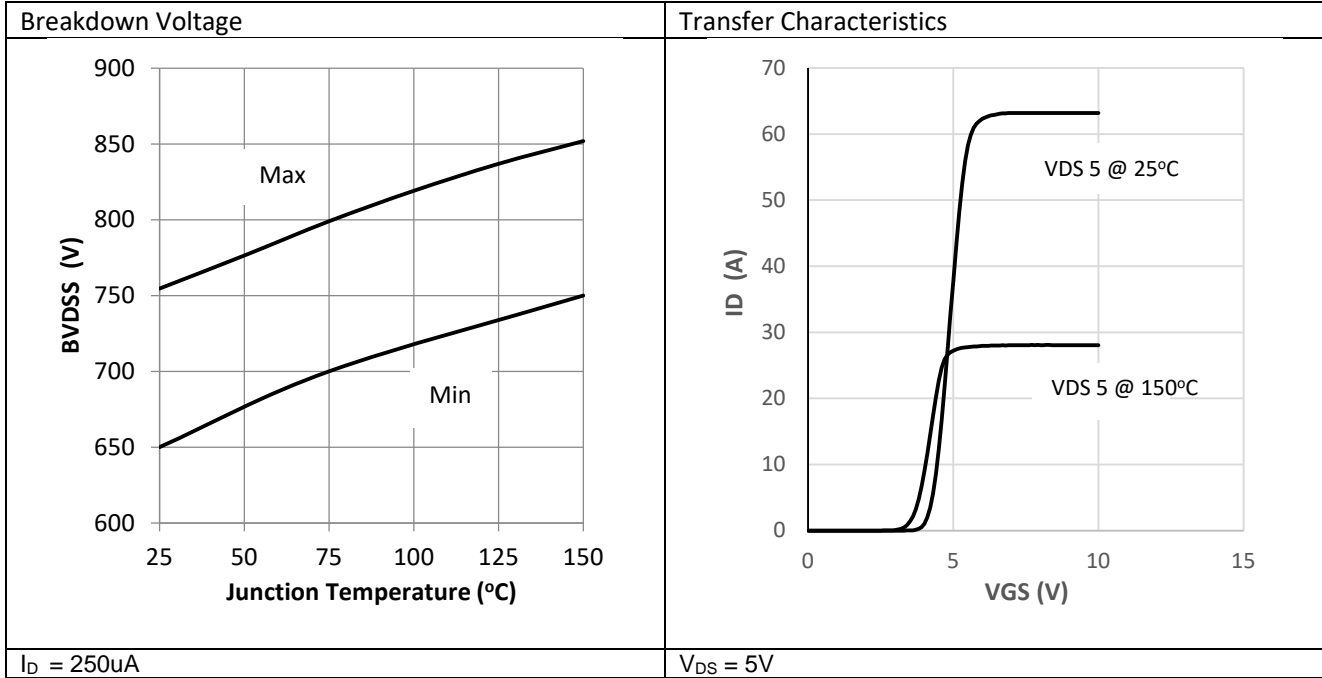


**Table 10 Drain-Source Resistance**

**Table 11 Safe Operating Area**


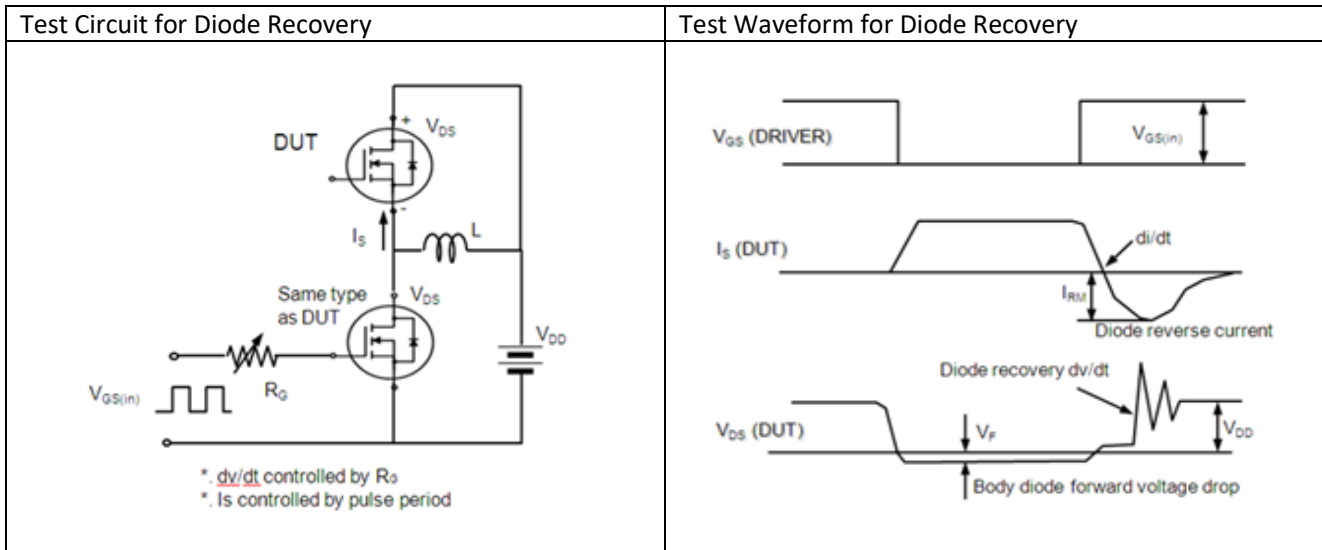


**Table 12 Typical Capacitances and Gate Charge**

**Table 13 Diode Forward Characteristics and Avalanche Energy**


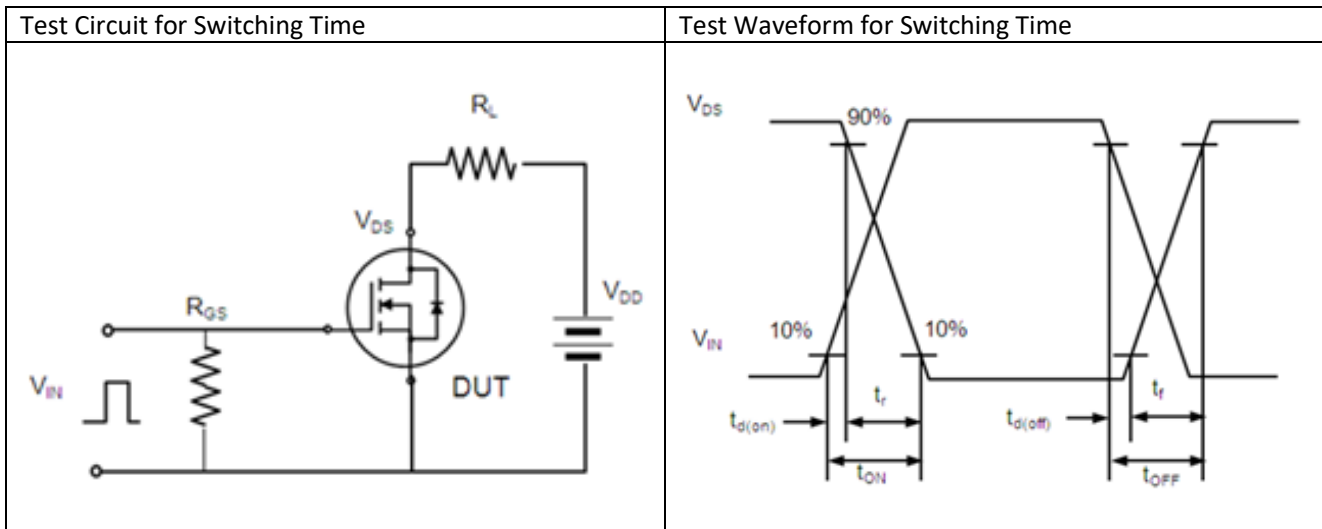
**Table 14 Drain – Source Breakdown Voltage and Typical Transfer Characteristics**



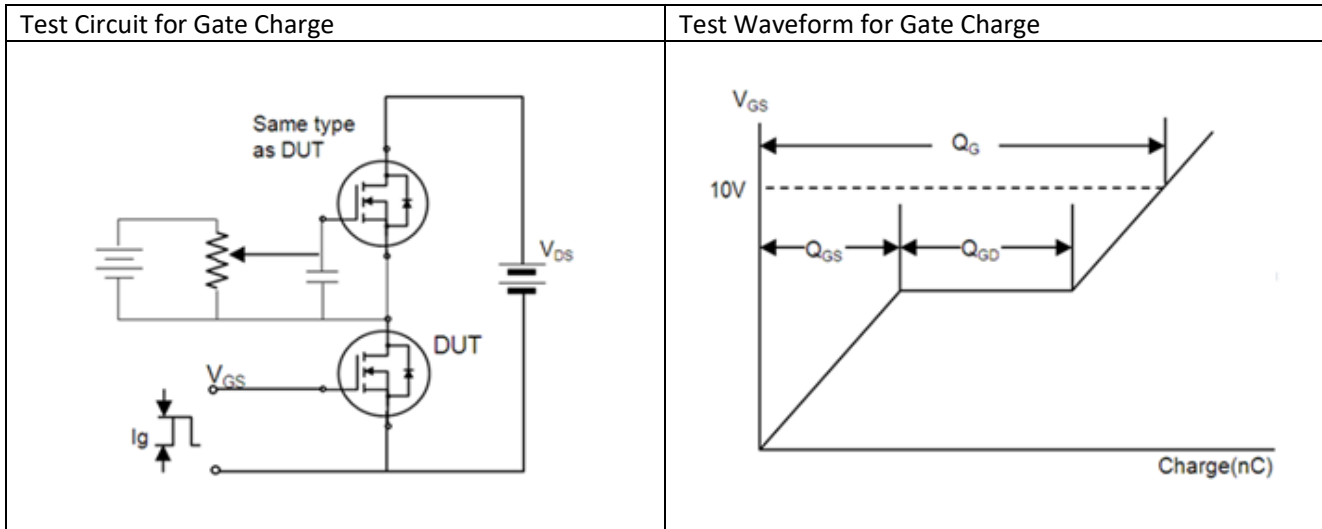
**Table 15 Diode Recovery Characteristics**



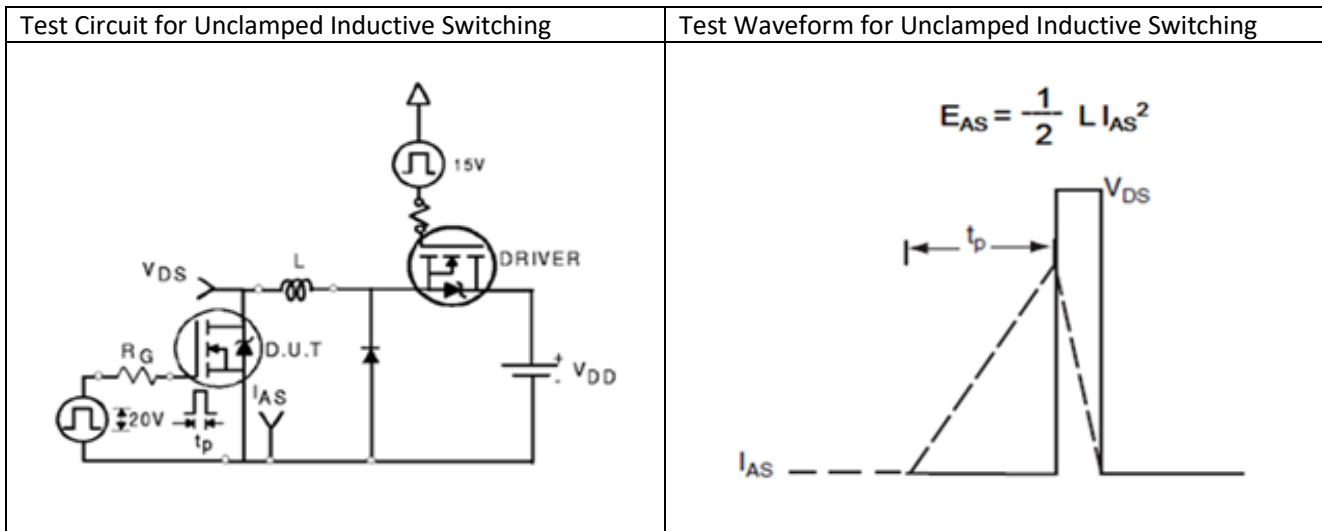
**Table 16 Switching Time Characteristics**



**Table 17 Gate Charge Characteristics**



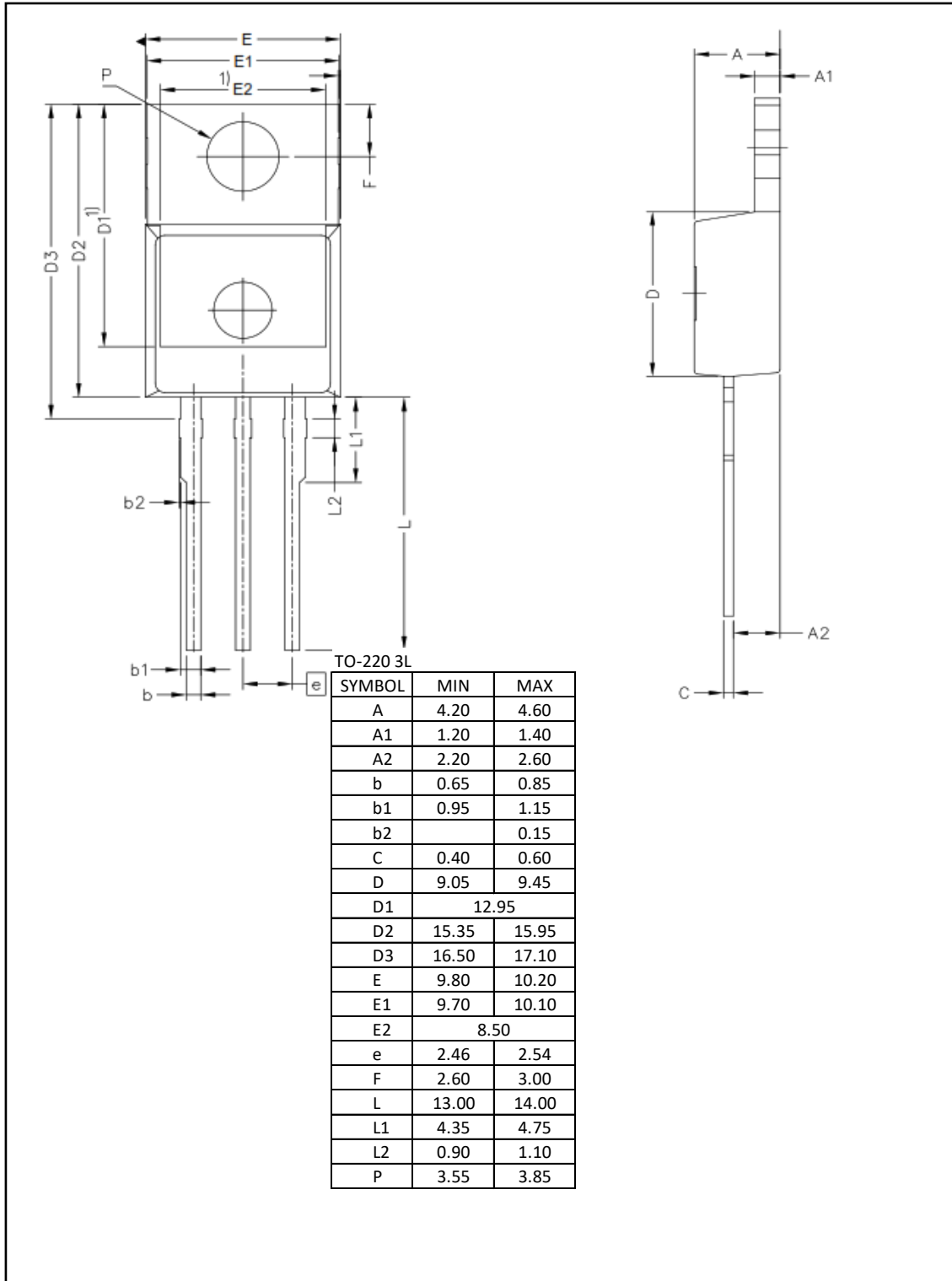
**Table 18 Unclamped Inductive Switching Characteristic**



Package Outlines

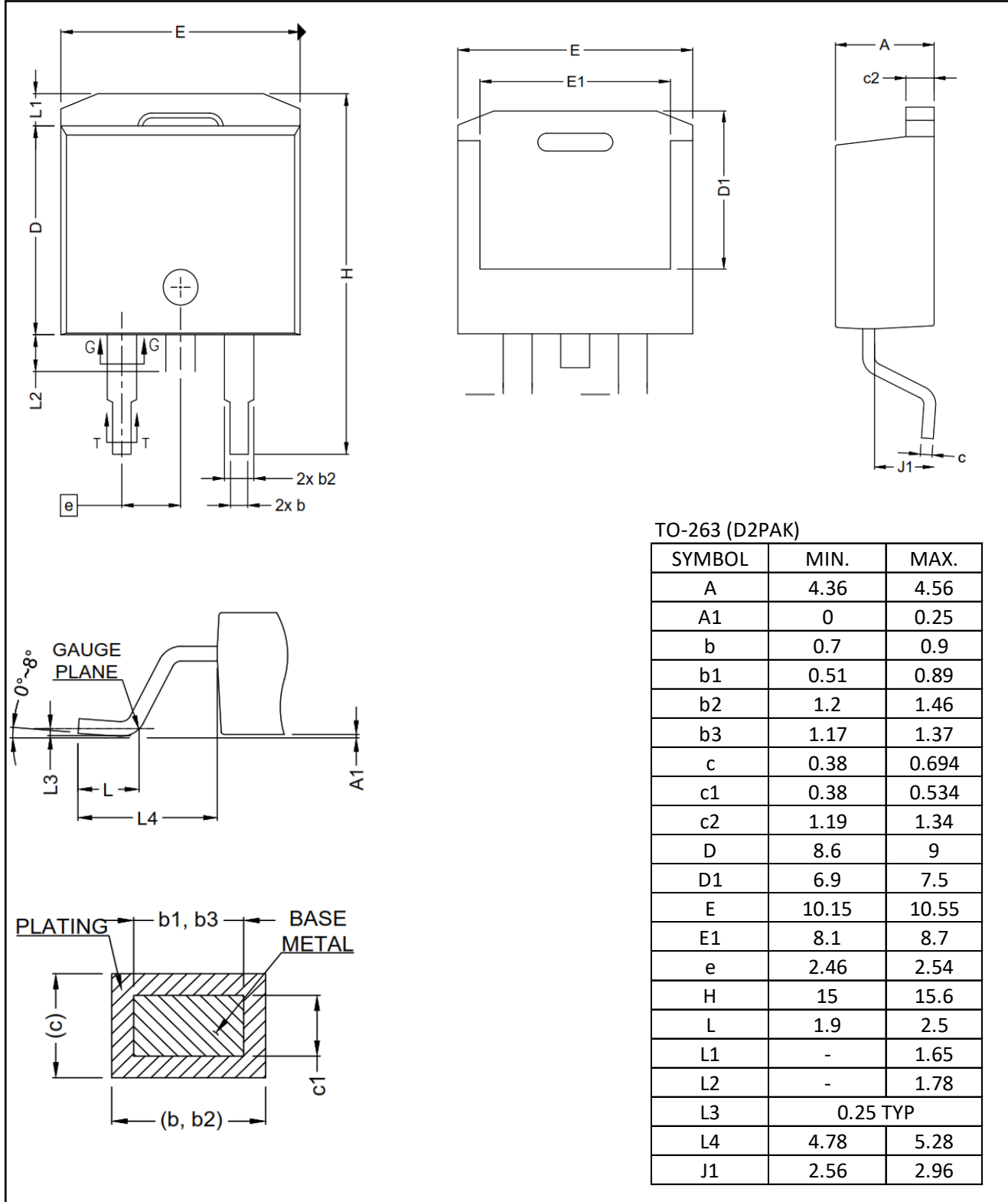
4a) TO-220

**D3 Semiconductor TO-220-3L**



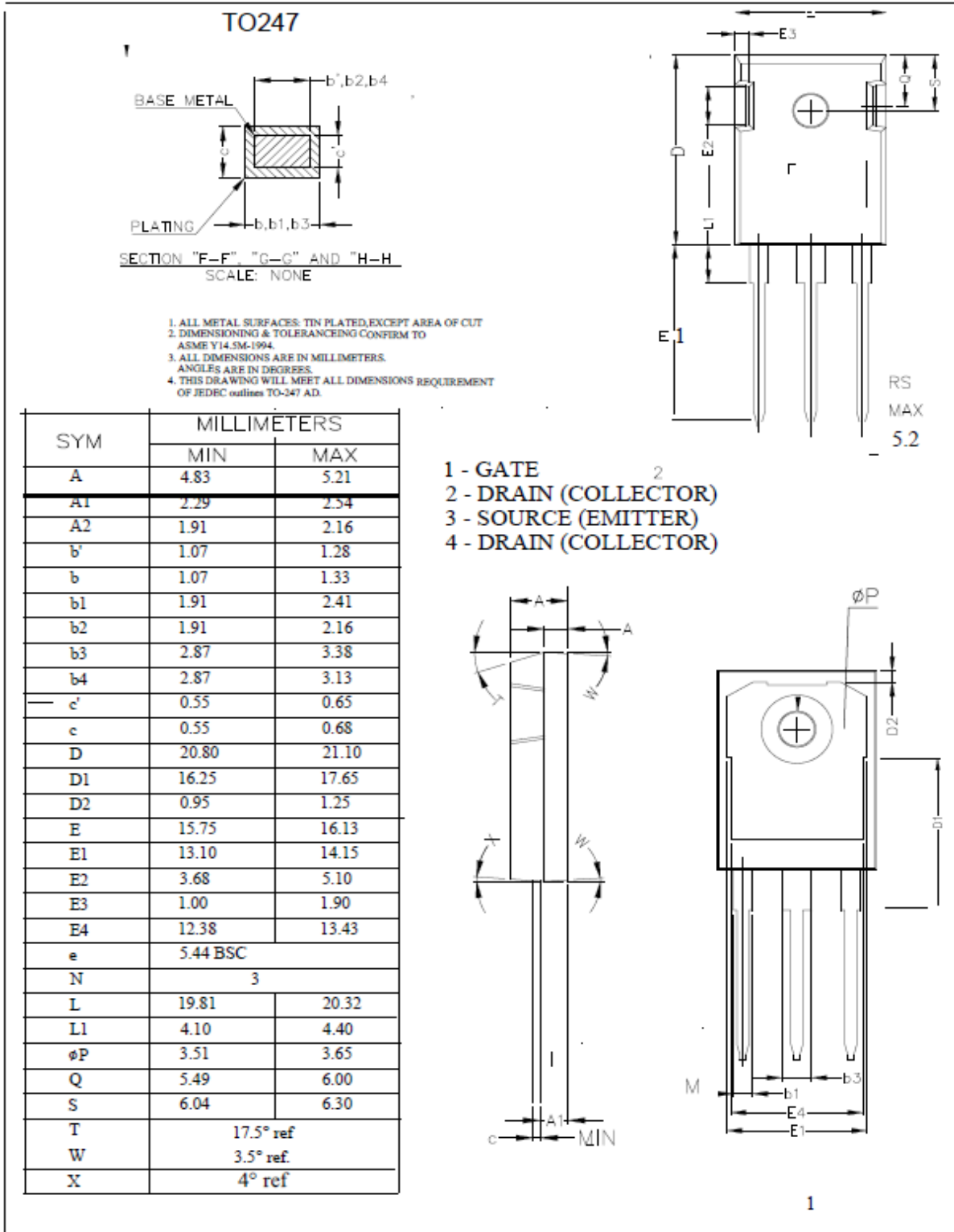
4b) TO-263

**D3 Semiconductor TO-263 (D2PAK)**



4c) TO-247

**D3 Semiconductor TO-247 -3L**



## Revision History

Revision	Release Date	Comments
1.0	1-Nov-2016	Preliminary Datasheet
1.1	1-July-2017	Updated data tables and added packaging detail
2.3	20-Nov-2017	Added TO247 Package and Designers Datasheet
2.4	11-Dec-2017	Added Test Circuits

## Resources

[www.d3semi.com](http://www.d3semi.com)

## Patents, Copyrights and Trademarks

U.S. and Foreign Patents Pending.

The following are trademarks and service marks owned by D3 Semiconductor:

D3 Semiconductor<sup>®</sup>, “Flying D” <sup>®</sup>, +FET<sup>™</sup>, Defining Precision Power<sup>™</sup>.

All trademarks are property of their respective owners. © D3 Semiconductor 2016. All rights reserved

## Legal Disclaimer

The information in this document is provided solely regarding D3 Semiconductor (“D3”) products. The information is not a guarantee of performance or characteristics. D3 Semiconductor reserves the right to modify, change, amend, improve or make corrections to this document, and its products, at any time and its sole discretion without prior written consent or notice. No license to any intellectual property rights is granted or implied under this document. D3 Semiconductor disclaims warranties and liabilities of any kind including non-infringement of intellectual property rights of any third party. D3 Semiconductor products may be used in applications such as automotive, military, aerospace, medical or other applications where failure or malfunction may result in personal injury, death or severe property or environmental damage only with express written approval from D3 Semiconductor. Sale of D3 Semiconductor products are subject to D3 Semiconductor’s standard terms and conditions. Products not purchased through D3 Semiconductor’s authorized distributors, agents or sales representatives are void of warranty.





## Стандарт Электрон Связь

Мы молодая и активно развивающаяся компания в области поставок электронных компонентов. Мы поставляем электронные компоненты отечественного и импортного производства напрямую от производителей и с крупнейших складов мира.

Благодаря сотрудничеству с мировыми поставщиками мы осуществляем комплексные и плановые поставки широчайшего спектра электронных компонентов.

Собственная эффективная логистика и склад в обеспечивает надежную поставку продукции в точно указанные сроки по всей России.

Мы осуществляем техническую поддержку нашим клиентам и предпродажную проверку качества продукции. На все поставляемые продукты мы предоставляем гарантию .

Осуществляем поставки продукции под контролем ВП МО РФ на предприятия военно-промышленного комплекса России , а также работаем в рамках 275 ФЗ с открытием отдельных счетов в уполномоченном банке. Система менеджмента качества компании соответствует требованиям ГОСТ ISO 9001.

Минимальные сроки поставки, гибкие цены, неограниченный ассортимент и индивидуальный подход к клиентам являются основой для выстраивания долгосрочного и эффективного сотрудничества с предприятиями радиоэлектронной промышленности, предприятиями ВПК и научно-исследовательскими институтами России.

С нами вы становитесь еще успешнее!

### Наши контакты:

**Телефон:** +7 812 627 14 35

**Электронная почта:** [sales@st-electron.ru](mailto:sales@st-electron.ru)

**Адрес:** 198099, Санкт-Петербург,  
Промышленная ул, дом № 19, литера Н,  
помещение 100-Н Офис 331