

APPLICATION MANUAL

RV-1805-C3

Extrem Low Power

Real Time Clock / Calendar Module

with I2C Interface

TABLE OF CONTENTS

| | |
|--|-----------|
| 1. OVERVIEW | 6 |
| 1.1. GENERAL DESCRIPTION..... | 6 |
| 1.2. APPLICATIONS..... | 7 |
| 2. BLOCK DIAGRAM..... | 8 |
| 2.1. PINOUT | 9 |
| 2.2. PIN DESCRIPTION | 10 |
| 2.3. FUNCTIONAL DESCRIPTION..... | 11 |
| 2.4. DEVICE PROTECTION DIAGRAM | 11 |
| 3. REGISTER ORGANIZATION | 12 |
| 3.1. REGISTER OVERVIEW..... | 12 |
| 3.2. TIME AND DATE REGISTERS..... | 14 |
| 3.3. ALARM REGISTERS..... | 17 |
| 3.4. CONFIGURATION REGISTERS..... | 20 |
| 3.5. CALIBRATION REGISTERS | 25 |
| 3.6. SLEEP CONTROL REGISTER..... | 27 |
| 3.7. TIMER REGISTERS..... | 28 |
| 3.8. OSCILLATOR REGISTERS..... | 31 |
| 3.9. MISCELLANEOUS REGISTERS..... | 32 |
| 3.10. ANALOG CONTROL REGISTERS | 33 |
| 3.11. ID REGISTERS | 35 |
| 3.12. RAM REGISTERS..... | 37 |
| 3.13. REGISTER RESET VALUES SUMMARY | 39 |
| 4. DETAILED FUNCTIONAL DESCRIPTION | 40 |
| 4.2. I²C INTERFACE | 41 |
| 4.2.1. BUS NOT BUSY..... | 41 |
| 4.2.2. BIT TRANSFER | 41 |
| 4.2.3. START AND STOP CONDITIONS | 41 |
| 4.2.4. DATA VALID | 42 |
| 4.2.5. SYSTEM CONFIGURATION | 42 |
| 4.2.6. ACKNOWLEDGE | 42 |
| 4.2.7. ADDRESSING..... | 43 |
| 4.2.8. WRITE OPERATION..... | 44 |
| 4.2.9. READ OPERATION AT SPECIFIC ADDRESS | 44 |
| 4.2.10. READ OPERATION | 45 |
| 4.3. XT OSCILLATOR..... | 45 |
| 4.4. RC OSCILLATOR | 45 |
| 4.5. RTC COUNTER ACCESS..... | 45 |
| 4.6. HUNDREDTHS SYNCHRONIZATION | 46 |

| | |
|--|-----------|
| 4.7. GENERATING HUNDREDTHS OF A SECOND | 46 |
| 4.8. WATCHDOG TIMER | 46 |
| 4.9. DIGITAL CALIBRATION..... | 47 |
| 4.9.1. XT OSCILLATOR DIGITAL CALIBRATION..... | 47 |
| 4.9.2. RC OSCILLATOR DIGITAL CALIBRATION | 48 |
| 4.10. AUTOCALIBRATION..... | 50 |
| 4.11. BASIC AUTOCALIBRATION OPERATION..... | 50 |
| 4.11.1. AUTOCALIBRATION OPERATION..... | 50 |
| 4.11.2. XT AUTOCALIBRATION MODE | 51 |
| 4.11.3. RC AUTOCALIBRATION MODE | 51 |
| 4.11.4. AUTOCALIBRATION FREQUENCY AND CONTROL | 51 |
| 4.11.5. Cap_RC PIN..... | 52 |
| 4.11.6. AUTOCALIBRATION FAILURE | 52 |
| 4.11.7. FREQUENCY ACCURACY IN RC AUTOCALIBRATION MODE..... | 52 |
| 4.11.8. A REAL WORLD EXAMPLE | 55 |
| 4.11.9. RC AUTOCALIBRATION TIMING ACCURACY EXAMPLE | 56 |
| 4.11.10. POWER ANALYSIS..... | 57 |
| 4.11.11. DISADVANTAGES RELATIVE TO THE XT OSCILLATOR | 57 |
| 4.12. XT OSCILLATOR FAILURE DETECTION | 58 |
| 4.13. INTERRUPTS..... | 58 |
| 4.13.1. INTERRUPT SUMMARY | 58 |
| 4.13.2. ALARM INTERRUPT AIRQ | 59 |
| 4.13.3. COUNTDOWN TIMER INTERRUPT TIRQ..... | 59 |
| 4.13.4. WATCHDOG TIMER INTERRUPT WIRQ | 59 |
| 4.13.5. BATTERY LOW INTERRUPT BLIRQ | 59 |
| 4.13.6. EXTERNAL INTERRUPT EIRQ..... | 59 |
| 4.13.7. XT OSCILLATOR FAILURE INTERRUPT OFIRQ | 59 |
| 4.13.8. AUTOCALIBRATION FAILURE INTERRUPT ACIRQ | 59 |
| 4.13.9. SERVICING INTERRUPTS | 60 |
| 4.14. POWER CONTROL AND SWITCHING..... | 60 |
| 4.14.1. AUTOMATIC SWITCHOVER SUMMARY | 61 |
| 4.14.2. BATTERY LOW FLAG AND INTERRUPT..... | 61 |
| 4.14.3. ANALOG COMPARATOR | 62 |
| 4.14.4. PIN CONTROL AND LEAKAGE MANAGEMENT (POWER CONTROL) | 62 |
| 4.14.5. POWER UP TIMING | 63 |
| 4.15. RESET SUMMARY | 63 |
| 4.15.1. POWER UP RESET | 64 |
| 4.15.2. WATCHDOG TIMER..... | 64 |
| 4.15.3. SLEEP | 65 |

| | |
|--|-----------|
| 4.16. SOFTWARE RESET | 65 |
| 4.17. SLEEP CONTROL STATE MACHINE | 65 |
| 4.17.1. RUN STATE | 66 |
| 4.17.2. SWAIT STATE (SLEEP_WAIT STATE)..... | 66 |
| 4.17.3. SLEEP STATE | 66 |
| 4.17.4. SLP PROTECTION | 68 |
| 4.17.5. PSWS, PSWB AND LKP..... | 68 |
| 4.17.6. PIN CONTROL AND LEAKAGE MANAGEMENT (SLEEP CONTROL) | 68 |
| 4.18. SYSTEM POWER CONTROL APPLICATIONS..... | 69 |
| 4.18.1. V_{SS} POWER SWITCHED | 69 |
| 4.18.2. V_{DD} POWER SWITCHED..... | 70 |
| 4.18.3. RESET DRIVEN..... | 70 |
| 4.18.4. INTERRUPT DRIVEN | 71 |
| 4.19. TYPICAL SYSTEM IMPLEMENTATION | 71 |
| 4.19.1. ALARMS..... | 72 |
| 4.19.2. COUNTDOWN TIMER | 72 |
| 4.19.3. WAKE BUTTON/SWITCH..... | 72 |
| 4.19.4. EXTERNAL DEVICE INPUT | 72 |
| 4.19.5. ANALOG INPUT..... | 72 |
| 4.19.6. BATTERY LOW DETECTION..... | 72 |
| 4.19.7. ERRORS | 72 |
| 4.20. SAVING PARAMETERS..... | 73 |
| 4.21. POWER SWITCH ELECTRICAL CHARACTERISTICS | 73 |
| 4.22. AVOIDING UNEXPECTED LEAKAGE PATHS | 73 |
| 4.23. SYSTEM POWER ANALYSIS | 73 |
| 4.23.1. USING AN EXTERNAL RTC WITH POWER MANAGEMENT..... | 73 |
| 4.23.2. MANAGING MCU ACTIVE POWER..... | 74 |
| 4.23.3. LOWER COST MCUs | 74 |
| 4.23.4. HIGH PERFORMANCE PROCESSORS..... | 74 |
| 4.24. TRICKLE CHARGER..... | 74 |
| 5. DIGITAL ARCHITECTURE SUMMARY | 75 |
| 6. ELECTRICAL SPECIFICATIONS..... | 76 |
| 6.1. ABSOLUTE MAXIMUM RATINGS | 76 |
| 6.2. POWER SUPPLY PARAMETERS | 76 |
| 6.3. OPERATING PARAMETERS | 78 |
| 6.4. OSCILLATOR PARAMETERS | 78 |
| 6.5. XT FREQUENCY CHARACTERISTICS | 80 |
| 6.5.1. XT FREQUENCY VS. TEMPERATURE CHARACTERISTICS..... | 80 |
| 6.6. V_{DD} SUPPLY CURRENT | 81 |

| | |
|---|----|
| 6.7. V_{BACKUP} SUPPLY CURRENT | 85 |
| 6.8. BREF ELECTRICAL CHARACTERISTICS..... | 88 |
| 6.9. \dot{I}^2C AC ELECTRICAL CHARACTERISTICS | 89 |
| 6.10. POWER ON AC ELECTRICAL CHARACTERISTICS | 90 |
| 6.11. $\overline{\text{RST}}$ AC ELECTRICAL CHARACTERISTICS..... | 91 |
| 7. APPLICATION INFORMATION..... | 92 |
| 7.1. OPERATING RV-1805-C3 | 92 |
| 7.2. OPERATING RV-1805-C3 WITH BACKUP BATTERY/SUPERCAP | 93 |
| 8. RECOMMENDED REFLOW TEMPERATURE (LEADFREE SOLDERING) | 94 |
| 9. PACKAGE..... | 95 |
| 9.1. DIMENSIONS AND SOLDERPADS LAYOUT | 95 |
| 9.2. MARKING AND PIN #1 INDEX..... | 95 |
| 10. PACKING INFORMATION..... | 96 |
| 10.1. CARRIER TAPE..... | 96 |
| 10.2. PARTS PER REEL..... | 96 |
| 10.3. REEL 7 INCH FOR 12 mm TAPE..... | 97 |
| 10.4. HANDLING PRECAUTIONS FOR CRYSTALS OR MODULES WITH EMBEDDED CRYSTALS | 98 |
| 11. DOCUMENT REVISION HISTORY..... | 99 |

RV-1805-C3

Extreme Low Power Real Time Clock / Calendar Module with I²C Interface

1. OVERVIEW

- Ultra-low supply current (all at 3V):
 - 17 nA with RC oscillator
 - 22 nA with RC oscillator and Autocalibration (ACP = 512 seconds)
 - 60 nA with crystal oscillator
- Baseline timekeeping features:
 - 32.768 kHz built-in “Tuning Fork” crystal oscillator with integrated load capacitor/resistor
 - Counters for hundredths, seconds, minutes, hours, date, month, year, century, and weekday
 - Alarm capability on all counters
 - Programmable output clock generation (32.768 kHz to 1/year)
 - Countdown timer with repeat function
 - Automatic leap year calculation
- Advanced timekeeping features:
 - Integrated power optimized RC oscillator
 - Factory calibrated frequency offset compensation to ± 2 ppm
 - Advanced RC calibration to ± 16 ppm
 - Automatic calibration of RC oscillator to the compensated crystal oscillator
 - Watchdog timer with hardware reset
 - Up to 512 bytes of general purpose RAM
- Power management features:
 - Integrated $\sim 1 \Omega$ power switch for off-chip components such as a host MCU
 - System sleep manager for managing host processor wake/sleep states
 - Reset output generator
 - Supercapacitor trickle charger with programmable charging current
 - Automatic switchover to V_{BACKUP}
 - External interrupt monitor
 - Programmable low battery detection threshold
 - Programmable analog voltage comparator
- I²C (up to 400 kHz) serial interface
- Operating voltage 1.5-3.6 V
- Clock and RAM retention voltage 1.5-3.6 V
- Operating temperature -40 to $+85$ °C
- All inputs include Schmitt Triggers
- Available in small and compact package size, RoHS-compliant and 100% leadfree: C3: 3.7 x 2.5 x 0.9 mm

1.1. GENERAL DESCRIPTION

The RV-1805-C3 Real Time Clock with Power Management provides a groundbreaking combination of ultra-low power coupled with a highly sophisticated feature set. The power requirement is significantly lower than any other industry RTC (as low as 17 nA). The RV-1805-C3 includes an on-chip oscillator to provide a minimum power consumption, full RTC functions including battery backup and programmable counters and alarms for timer and watchdog functions, and either an I²C serial interface for communication with a host controller. An integrated power switch and a sophisticated system sleep manager with counter, timer, alarm, and interrupt capabilities allows the RV-1805-C3 to be used as a supervisory component in a host microcontroller based system.

1.2. APPLICATIONS

The RV-1805-C3 RTC module has been specially designed for ultimate low power consumption:

- 60 nA with crystal oscillator (at 3V)
- 22 nA with RC oscillator and Autocalibration (ACP = 512 sec. at 3V)
- 17 nA with RC oscillator (at 3V)
- Permits to operate this RTC module several hours at Backup Supply Voltage using low-cost MLCC

These unique features make this product perfectly suitable for many applications:

- Communication: Wireless Sensors and Tags, Handsets, Communications equipment
- Automotive: Navigation & Tracking Systems / Dashboard / Tachometers / Car Audio & Entertainment Systems
- Metering: E-Meter / Heating Counter / Smart Meters / PV Converter
- Outdoor: ATM & POS systems / Ticketing Systems
- Medical: Glucose Meter / Health Monitoring Systems
- Safety: Security & Camera Systems / Door Lock & Access Control
- Consumer: Gambling Machines / TV & Set Top Boxes / White Goods
- Automation: Data Logger / Home & Factory Automation / Industrial and Consumer Electronics

2. BLOCK DIAGRAM

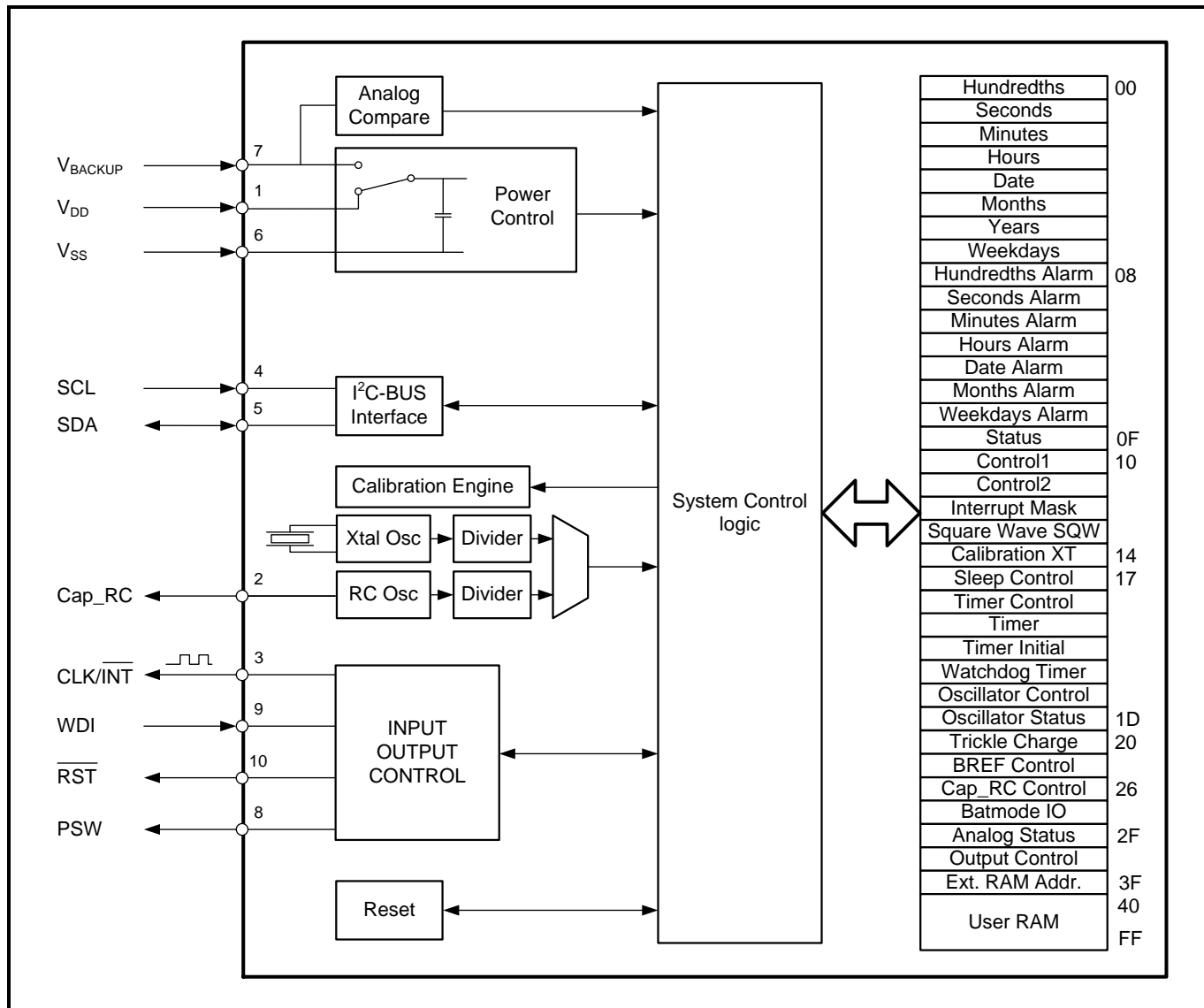

2.1. PINOUT

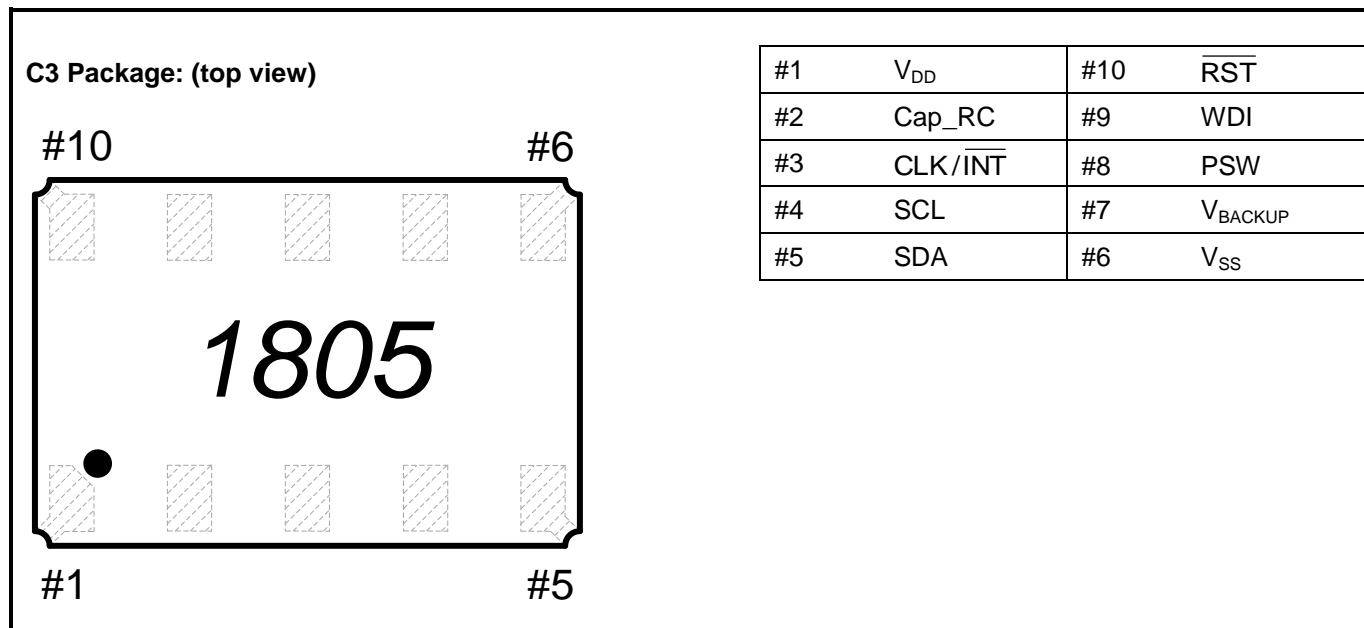

2.2. PIN DESCRIPTION

| Symbol | Pin # | Description |
|------------------------------|-------|---|
| V _{DD} | 1 | Primary power connection. If a single power supply is used, it must be connected to V _{DD} . |
| Cap_RC | 2 | Autocalibration filter connection. A 47 pF ceramic capacitor should be placed between this pin and V _{SS} for improved Autocalibration mode timing accuracy. |
| CLK/ $\overline{\text{INT}}$ | 3 | <p>Clock Output / Interrupt. Primary interrupt output connection. It is an open drain output. An external pull-up resistor must be added to this pin. It should be connected to the host device and is used to indicate when the RTC can be accessed via the I²C interface. CLK/$\overline{\text{INT}}$ may be configured to generate several signals as a function of the CLKS field (see CONFIGURATION REGISTERS, 11h - Control2). CLK/$\overline{\text{INT}}$ is also asserted low on a power up until the RV-1805-C3 has exited the reset state and is accessible via the I²C interface.</p> <ol style="list-style-type: none"> 1. CLK/$\overline{\text{INT}}$ can drive the static value of the CLKB bit. 2. CLK/$\overline{\text{INT}}$ can drive the inverse of the combined interrupt signal IRQ (see INTERRUPTS). 3. CLK/$\overline{\text{INT}}$ can drive the square wave signal SQW (see CONFIGURATION REGISTERS, 13h - Square Wave SQW) if enabled by SQWE. 4. CLK/$\overline{\text{INT}}$ can drive the inverse of the alarm interrupt signal AIRQ (see INTERRUPTS). |
| SCL | 4 | I ² C Serial Clock Input. A pull-up resistor is required on this pin. |
| SDA | 5 | I ² C Serial Data. A pull-up resistor is required on this pin. |
| V _{SS} | 6 | Ground connection |
| V _{BACKUP} | 7 | Backup Supply Voltage. If a backup voltage is not present, V _{BACKUP} is normally left floating or grounded, but it may also be used to provide the analog input to the internal comparator (see ANALOG COMPARATOR). Requires series resistor. The optimal total series impedance = V _{BACKUP} power source ESR (Equivalent Series Resistance) + external resistor value = 1.5 k Ω . |
| PSW | 8 | <p>Power Switch Output. Secondary interrupt output connection. It is an open drain output. This pin can be left floating if not used. PSW may be configured to generate several signals as a function of the PSWS field (see CONFIGURATION REGISTERS, 11h - Control2). This pin will be configured as an ~1 Ω switch if the PSWC bit is set.</p> <ol style="list-style-type: none"> 1. PSW can drive the static value of the PSWB bit. 2. PSW can drive the square wave signal SQW (see CONFIGURATION REGISTERS, 13h - Square Wave SQW) if enabled by SQWE. 3. PSW can drive the inverse of the combined interrupt signal IRQ (see INTERRUPTS). 4. PSW can drive the inverse of the alarm interrupt signal AIRQ (see INTERRUPTS). 5. PSW can drive the inverse or the not inverse of the timer interrupt signal TIRQ. 6. PSW can function as the power switch output for controlling the power of external devices (see SLEEP CONTROL). |
| WDI | 9 | Watchdog Timer reset input connection. It may also be used to generate an External interrupt with polarity selected by the EIP bit if enabled by the EIE bit. The value of the WDI pin may be read in the WDIS register bit. This pin does not have an internal pull-up or pull-down resistor and so one must be added externally. It must not be left floating or the RTC may consume higher current. Instead, it must be connected directly to either V _{DD} or V _{SS} if not used. |
| $\overline{\text{RST}}$ | 10 | Reset Output. It is an open drain output. If this pin is used, an external pull-up resistor must be added to this pin. If the pin is not used, it can be left floating. The polarity is selected by the RSTP bit, which will initialize to 0 on power up to produce an active low output. See AUTOCALIBRATION FAILURE INTERRUPT ACIRQ for details of the generation of $\overline{\text{RST}}$. |

2.3. FUNCTIONAL DESCRIPTION

The RV-1805-C3 is an extreme low power CMOS Real-Time Clock / Calendar module with built-in “Tuning-Fork” crystal with the nominal frequency of 32.768 kHz and an on-chip auto-calibrated RC-oscillator; no external components are required for the oscillator circuitry.

The oscillator frequency on all devices is tested not to exceed a time deviation of ± 20 ppm (parts per million) at 25°C, which equates to about ± 52 seconds per month.

This time accuracy can be further improved to ± 2 ppm (factory calibrated at 25°C) or better by individually measuring the frequency-deviation in the application at a given temperature and programming a correction value into the frequency compensation register.

Up to 512 bytes/registers of general purpose ultra-low leakage RAM enable the storage of key parameters when operating on backup power.

The registers are accessed by selecting a register address and then performing read or write operations. Multiple reads or writes may be executed in a single access, with the address automatically incrementing after each byte.

2.4. DEVICE PROTECTION DIAGRAM

The following Figure illustrates the internal ESD structure. The ESD Clamp devices are not simple diodes and are more complex structured. The V_{DD} , V_{BACKUP} and Cap_RC pins have these ESD clamps as well as the internal V_{SYS} supply, which route a positive ESD discharge to V_{SS} . Note that the V_{SYS} internal supply is switched between the V_{DD} and V_{BACKUP} supplies dependent upon the mode of operation. In V_{BACKUP} mode (when V_{DD} goes away with a V_{BACKUP} supply present), the internal V_{SYS} supply is switched to V_{BACKUP} by additional internal circuitry. In V_{DD} mode (when V_{DD} is present and regardless if a supply is present on V_{BACKUP} or not), the internal V_{SYS} supply is switched to V_{DD} by additional internal circuitry. Note that V_{SYS} does not directly touch a pin, but all of the positive charge injected onto the other digital I/O pads (CLK/\overline{INT} , SCL , SDA , PSW , WDI and \overline{RST}) gets routed to this ESD clamp on V_{SYS} . In addition, there are simple diodes between V_{SYS} and V_{SS} as well as between the digital I/O pads and V_{SS} as shown in the diagram. These diodes take care of negative discharges to any of those pads.

Internal ESD structure:

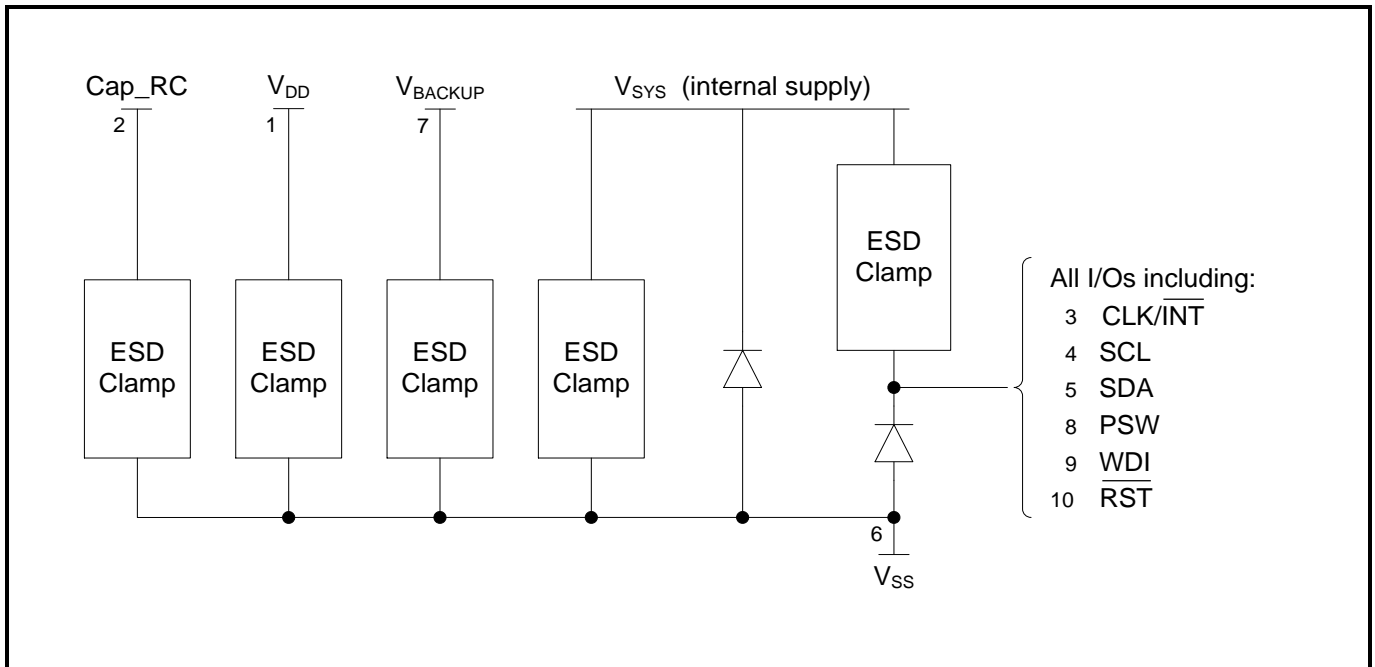

3. REGISTER ORGANIZATION

Registers are accessed by selecting a register address and then performing read or write operations. Multiple reads or writes may be executed in a single access, with the address automatically incrementing after each byte. The following tables Register Definitions (00h to 0Fh) and Register Definitions (10h to FFh) summarize the function of each register. In the table Register Definitions (00h to 0Fh), the GPx bits (where x is between 0 and 27) are 28 register bits which may be used as general purpose storage. These bits are not described in the sections below. All of the GPx bits are cleared when the RV-1805-C3 powers up, and they can therefore be used to allow software to determine if a true Power On Reset (POR) has occurred or hold other initialization data.

3.1. REGISTER OVERVIEW

Register Definitions (00h to 0Fh):

| Address | Function | Bit 7 | Bit 6 | Bit 5 | Bit 4 | Bit 3 | Bit 2 | Bit 1 | Bit 0 |
|---------|-----------------------|-------|-------|-------|-------|-------|-------|-------|-------|
| 00h | Hundredths | 80 | 40 | 20 | 10 | 8 | 4 | 2 | 1 |
| 01h | Seconds | GP0 | 40 | 20 | 10 | 8 | 4 | 2 | 1 |
| 02h | Minutes | GP1 | 40 | 20 | 10 | 8 | 4 | 2 | 1 |
| 03h | Hours (24 hour) | GP3 | GP2 | 20 | 10 | 8 | 4 | 2 | 1 |
| | Hours (12 hour) | GP3 | GP2 | AM/PM | 10 | 8 | 4 | 2 | 1 |
| 04h | Date | GP5 | GP4 | 20 | 10 | 8 | 4 | 2 | 1 |
| 05h | Months | GP8 | GP7 | GP6 | 10 | 8 | 4 | 2 | 1 |
| 06h | Years | 80 | 40 | 20 | 10 | 8 | 4 | 2 | 1 |
| 07h | Weekdays | GP13 | GP12 | GP11 | GP10 | GP9 | 4 | 2 | 1 |
| 08h | Hundredths Alarm | 80 | 40 | 20 | 10 | 8 | 4 | 2 | 1 |
| 09h | Seconds Alarm | GP14 | 40 | 20 | 10 | 8 | 4 | 2 | 1 |
| 0Ah | Minutes Alarm | GP15 | 40 | 20 | 10 | 8 | 4 | 2 | 1 |
| 0Bh | Hours Alarm (24 hour) | GP17 | GP16 | 20 | 10 | 8 | 4 | 2 | 1 |
| | Hours Alarm (12 hour) | GP17 | GP16 | AM/PM | 10 | 8 | 4 | 2 | 1 |
| 0Ch | Date Alarm | GP19 | GP18 | 20 | 10 | 8 | 4 | 2 | 1 |
| 0Dh | Months Alarm | GP22 | GP21 | GP20 | 10 | 8 | 4 | 2 | 1 |
| 0Eh | Weekdays Alarm | GP27 | GP26 | GP25 | GP24 | GP23 | 4 | 2 | 1 |
| 0Fh | Status | CB | BAT | WDF | BLF | TF | AF | EVF | X |

Register Definitions (10h to FFh):

| Address | Function | Bit 7 | Bit 6 | Bit 5 | Bit 4 | Bit 3 | Bit 2 | Bit 1 | Bit 0 | |
|-----------------|----------------------------|--|-----------------|----------------|-------|----------|------------------------|----------|----------|--|
| 10h | Control1 | STOP | 12/24 | PSWB | CLKB | RSTP | ARST | PSWC | WRTC | |
| 11h | Control2 | RESERVED | | X | PSWS | | | CLKS | | |
| 12h | Interrupt Mask | CBE | IM | | BLIE | TIE | AIE | EIE | X | |
| 13h | Square Wave SQW | SQWE | RESERVED | | SQWS | | | | | |
| 14h | Calibration XT | CMDX | OFFSETX | | | | | | | |
| 15h | Calibration RC Upper | CMDR | | OFFSETRU[13:8] | | | | | | |
| 16h | Calibration RC Lower | OFFSETRL[7:0] | | | | | | | | |
| 17h | Sleep Control | SLP | SLRST | EIP | X | SLF | SLW | | | |
| 18h | Countdown Timer Control | TE | TM | TRPT | ARPT | | | TFS | | |
| 19h | Countdown Timer | 128 | 64 | 32 | 16 | 8 | 4 | 2 | 1 | |
| 1Ah | Timer Initial Value | 128 | 64 | 32 | 16 | 8 | 4 | 2 | 1 | |
| 1Bh | Watchdog Timer | WDS | WDM | | | | WD | | | |
| 1Ch | Oscillator Control | OSEL | ACAL | | BOS | FOS | IOPW | OFIE | ACIE | |
| 1Dh | Oscillator Status Register | XTCAL | | LKP | OMODE | RESERVED | | OF | ACF | |
| 1Eh | RESERVED | RESERVED | | | | | | | | |
| 1Fh | Configuration Key | CONFKEY | | | | | | | | |
| 20h | Trickle Charge | TCS | | | | DIODE | | ROUT | | |
| 21h | BREF Control | BREF | | | | RESERVED | | | | |
| 22h | RESERVED | RESERVED | | | | | | | | |
| 23h | RESERVED | RESERVED | | | | | | | | |
| 24h | RESERVED | RESERVED | | | | | | | | |
| 25h | RESERVED | RESERVED | | | | | | | | |
| 26h | Cap_RC Control | CAPRC | | | | | | | | |
| 27h | IO Batmode Register | IOBM | RESERVED | | | | | | | |
| 28h | ID0 (Read only) | Part Number – MS Byte = 00011000 (18h) | | | | | | | | |
| 29h | ID1 (Read only) | Part Number – LS Byte = 00000101 (05h) | | | | | | | | |
| 2Ah | ID2 (Read only) | Revision – Major = 00010 | | | | | Revision – Minor = 011 | | | |
| 2Bh | ID3 (Read only) | Lot[7:0] | | | | | | | | |
| 2Ch | ID4 (Read only) | Lot[9] | Unique ID[14:8] | | | | | | | |
| 2Dh | ID5 (Read only) | Unique ID[7:0] | | | | | | | | |
| 2Eh | ID6 (Read only) | Lot[8] | Wafer | | | | | RESERVED | | |
| 2Fh | Analog Stat. (Read Only) | BREFD | BMIN | RESERVED | | | | VINIT | RESERVED | |
| 30h | Output Control Register | WDBM | X | WDDS | X | RSTSL | X | X | CLKSL | |
| 3Fh | Extension RAM Address | X | BPOL | WDIS | X | RESERVED | XADA | XADS | | |
| 40h : 7Fh | Standard RAM | RAM data (4 x 64 bytes = 256 bytes) | | | | | | | | |
| 80h : FFh | Alternate RAM | RAM data (2 x 128 bytes = 256 bytes) | | | | | | | | |

3.2. TIME AND DATE REGISTERS

00h - Hundredths

This register holds the count of hundredths of seconds, in two binary coded decimal (BCD) digits. Values will be from 00 to 99. Note that in order to divide from 32.768 kHz, the hundredths register will not be fully accurate at all times but will be correct every 500 ms. Maximum jitter of this register will be less than 1 ms. The Hundredths Counter is not valid if the RC Oscillator is selected.

| Address | Function | Bit 7 | Bit 6 | Bit 5 | Bit 4 | Bit 3 | Bit 2 | Bit 1 | Bit 0 |
|---------|------------|----------|--|-------|-------|-------|-------|-------|-------|
| 00h | Hundredths | 80 | 40 | 20 | 10 | 8 | 4 | 2 | 1 |
| | Reset | 1 | 0 | 0 | 1 | 1 | 0 | 0 | 1 |
| Bit | Symbol | Value | Description | | | | | | |
| 7:0 | Hundredths | 00 to 99 | Holds the count of hundredths of seconds, coded in BCD format. | | | | | | |

01h - Seconds

This register holds the count of seconds, in two binary coded decimal (BCD) digits. Values will be from 00 to 59.

| Address | Function | Bit 7 | Bit 6 | Bit 5 | Bit 4 | Bit 3 | Bit 2 | Bit 1 | Bit 0 |
|---------|----------|----------|--|-------|-------|-------|-------|-------|-------|
| 01h | Seconds | GP0 | 40 | 20 | 10 | 8 | 4 | 2 | 1 |
| | Reset | 0 | 0 | 0 | 0 | 0 | 0 | 0 | 0 |
| Bit | Symbol | Value | Description | | | | | | |
| 7 | GP0 | 0 or 1 | Register bit for general purpose use. | | | | | | |
| 6:0 | Seconds | 00 to 59 | Holds the count of seconds, coded in BCD format. | | | | | | |

02h – Minutes

This register holds the count of minutes, in two binary coded decimal (BCD) digits. Values will be from 00 to 59.

| Address | Function | Bit 7 | Bit 6 | Bit 5 | Bit 4 | Bit 3 | Bit 2 | Bit 1 | Bit 0 |
|---------|----------|----------|--|-------|-------|-------|-------|-------|-------|
| 02h | Minutes | GP1 | 40 | 20 | 10 | 8 | 4 | 2 | 1 |
| | Reset | 0 | 0 | 0 | 0 | 0 | 0 | 0 | 0 |
| Bit | Symbol | Value | Description | | | | | | |
| 7 | GP1 | 0 or 1 | Register bit for general purpose use. | | | | | | |
| 6:0 | Minutes | 00 to 59 | Holds the count of minutes, coded in BCD format. | | | | | | |

03h - Hours

This register holds the count of hours, in two binary coded decimal (BCD) digits. Values will be from 00 to 23 if the 12/24 bit (see CONFIGURATION REGISTERS, 10h - Control1) is clear. If the 12/24 bit is set, the AM/PM bit will be 0 for AM hours and 1 for PM hours, and hour values will range from 1 to 12.

Hours Register (24 Hour Mode)

| Address | Function | Bit 7 | Bit 6 | Bit 5 | Bit 4 | Bit 3 | Bit 2 | Bit 1 | Bit 0 |
|---------|----------|----------|--|-------|-------|-------|-------|-------|-------|
| 03h | Hours | GP3 | GP2 | 20 | 10 | 8 | 4 | 2 | 1 |
| | Reset | 0 | 0 | 0 | 0 | 0 | 0 | 0 | 0 |
| Bit | Symbol | Value | Description | | | | | | |
| 7 | GP3 | 0 or 1 | Register bit for general purpose use. | | | | | | |
| 6 | GP2 | 0 or 1 | Register bit for general purpose use. | | | | | | |
| 5:0 | Hours | 00 to 23 | Holds the count of hours, coded in BCD format. | | | | | | |

Hours Register (12 Hour Mode)

| Address | Function | Bit 7 | Bit 6 | Bit 5 | Bit 4 | Bit 3 | Bit 2 | Bit 1 | Bit 0 |
|---------|----------|---------|--|-------|-------|-------|-------|-------|-------|
| 03h | Hours | GP3 | GP2 | AM/PM | 10 | 8 | 4 | 2 | 1 |
| | Reset | 0 | 0 | 0 | 0 | 0 | 0 | 0 | 0 |
| Bit | Symbol | Value | Description | | | | | | |
| 7 | GP3 | 0 or 1 | Register bit for general purpose use. | | | | | | |
| 6 | GP2 | 0 or 1 | Register bit for general purpose use. | | | | | | |
| 5 | AM/PM | 0 | AM hours. | | | | | | |
| | | 1 | PM hours. | | | | | | |
| 4:0 | Hours | 1 to 12 | Holds the count of hours, coded in BCD format. | | | | | | |

04h – Date

This register holds the current day of the month, in two binary coded decimal (BCD) digits. Values will range from 01 to 31. Leap years are correctly handled from 1900 to 2199.

| Address | Function | Bit 7 | Bit 6 | Bit 5 | Bit 4 | Bit 3 | Bit 2 | Bit 1 | Bit 0 |
|---------|----------|----------|--|-------|-------|-------|-------|-------|-------|
| 04h | Date | GP5 | GP4 | 20 | 10 | 8 | 4 | 2 | 1 |
| | Reset | 0 | 0 | 0 | 0 | 0 | 0 | 0 | 1 |
| Bit | Symbol | Value | Description | | | | | | |
| 7 | GP5 | 0 or 1 | Register bit for general purpose use. | | | | | | |
| 6 | GP4 | 0 or 1 | Register bit for general purpose use. | | | | | | |
| 5:0 | Date | 01 to 31 | Holds the current day of the month, coded in BCD format. | | | | | | |

05h - Months

This register holds the current month, in two binary coded decimal (BCD) digits. Values will range from 01 to 12.

| Address | Function | Bit 7 | Bit 6 | Bit 5 | Bit 4 | Bit 3 | Bit 2 | Bit 1 | Bit 0 |
|---------|----------|----------|---|-------|-------|-------|-------|-------|-------|
| 05h | Months | GP8 | GP7 | GP6 | 10 | 8 | 4 | 2 | 1 |
| | Reset | 0 | 0 | 0 | 0 | 0 | 0 | 0 | 1 |
| Bit | Symbol | Value | Description | | | | | | |
| 7 | GP8 | 0 or 1 | Register bit for general purpose use. | | | | | | |
| 6 | GP7 | 0 or 1 | Register bit for general purpose use. | | | | | | |
| 5 | GP6 | 0 or 1 | Register bit for general purpose use. | | | | | | |
| 4:0 | Months | 01 to 12 | Holds the current month, coded in BCD format. | | | | | | |

06h - Years

This register holds the current year, in two binary coded decimal (BCD) digits. Values will range from 00 to 99.

| Address | Function | Bit 7 | Bit 6 | Bit 5 | Bit 4 | Bit 3 | Bit 2 | Bit 1 | Bit 0 |
|---------|----------|----------|--|-------|-------|-------|-------|-------|-------|
| 06h | Years | 80 | 40 | 20 | 10 | 8 | 4 | 2 | 1 |
| | Reset | 0 | 0 | 0 | 0 | 0 | 0 | 0 | 0 |
| Bit | Symbol | Value | Description | | | | | | |
| 7:0 | Years | 00 to 99 | Holds the current year, coded in BCD format. When the Years register rolls over from 99 to 00 the Century bit CB will be toggled (see CONFIGURATION REGISTERS, 0Fh - Status) if the CBE bit is a 1 (see CONFIGURATION REGISTERS, 12h - Interrupt Mask). | | | | | | |

07h - Weekdays

This register holds the current day of the week. Values will range from 0 to 6.

| Address | Function | Bit 7 | Bit 6 | Bit 5 | Bit 4 | Bit 3 | Bit 2 | Bit 1 | Bit 0 |
|---------|----------|--------|---------------------------------------|-------|-------|-------|-------|-------|-------|
| 07h | Weekdays | GP13 | GP12 | GP11 | GP10 | GP09 | 4 | 2 | 1 |
| | Reset | 0 | 0 | 0 | 0 | 0 | 0 | 0 | 0 |
| Bit | Symbol | Value | Description | | | | | | |
| 7 | GP13 | 0 or 1 | Register bit for general purpose use. | | | | | | |
| 6 | GP12 | 0 or 1 | Register bit for general purpose use. | | | | | | |
| 5 | GP11 | 0 or 1 | Register bit for general purpose use. | | | | | | |
| 4 | GP10 | 0 or 1 | Register bit for general purpose use. | | | | | | |
| 3 | GP09 | 0 or 1 | Register bit for general purpose use. | | | | | | |
| 2:0 | Weekdays | 0 to 6 | Holds the weekday counter value. | | | | | | |

3.3. ALARM REGISTERS

08h - Hundredths Alarm

This register holds the alarm value for hundredths of seconds, in two binary coded decimal (BCD) digits. Values will range from 00 to 99. It holds the special values FFh and (F0h to F9h) when ARPT bit is 7. See TIMER REGISTERS, 18h - Countdown Timer Control.

| Address | Function | Bit 7 | Bit 6 | Bit 5 | Bit 4 | Bit 3 | Bit 2 | Bit 1 | Bit 0 |
|---------|------------------|------------|--|-------|-------|-------|-------|-------|-------|
| 08h | Hundredths Alarm | 80 | 40 | 20 | 10 | 8 | 4 | 2 | 1 |
| | Reset | 0 | 0 | 0 | 0 | 0 | 0 | 0 | 0 |
| Bit | Symbol | Value | Description | | | | | | |
| 7:0 | Hundredths Alarm | FFh | Once per hundredth in XT mode. Once per second in RC mode. ARPT bit must be 7. | | | | | | |
| | | F0h to F9h | Once per tenth in XT mode. Once per second in RC mode. ARPT bit must be 7. | | | | | | |
| | | 00 to 99 | Holds the alarm value for hundredths of seconds, coded in BCD format. If the ARPT bit is 0 to 6. | | | | | | |

09h - Seconds Alarm

This register holds the alarm value for seconds, in two binary coded decimal (BCD) digits. Values will range from 00 to 59.

| Address | Function | Bit 7 | Bit 6 | Bit 5 | Bit 4 | Bit 3 | Bit 2 | Bit 1 | Bit 0 |
|---------|---------------|----------|---|-------|-------|-------|-------|-------|-------|
| 09h | Seconds Alarm | GP14 | 40 | 20 | 10 | 8 | 4 | 2 | 1 |
| | Reset | 0 | 0 | 0 | 0 | 0 | 0 | 0 | 0 |
| Bit | Symbol | Value | Description | | | | | | |
| 7 | GP14 | 0 or 1 | Register bit for general purpose use. | | | | | | |
| 6:0 | Seconds Alarm | 00 to 59 | Holds the alarm value for seconds, coded in BCD format. | | | | | | |

0Ah - Minutes Alarm

This register holds the alarm value for minutes, in two binary coded decimal (BCD) digits. Values will range from 00 to 59.

| Address | Function | Bit 7 | Bit 6 | Bit 5 | Bit 4 | Bit 3 | Bit 2 | Bit 1 | Bit 0 |
|---------|---------------|----------|---|-------|-------|-------|-------|-------|-------|
| 0Ah | Minutes Alarm | GP15 | 40 | 20 | 10 | 8 | 4 | 2 | 1 |
| | Reset | 0 | 0 | 0 | 0 | 0 | 0 | 0 | 0 |
| Bit | Symbol | Value | Description | | | | | | |
| 7 | GP15 | 0 or 1 | Register bit for general purpose use. | | | | | | |
| 6:0 | Minutes Alarm | 00 to 59 | Holds the alarm value for minutes, coded in BCD format. | | | | | | |

0Bh - Hours Alarm

This register holds the alarm value for hours, in two binary coded decimal (BCD) digits. Values will range from 00 to 23 if the 12/24 bit (see CONFIGURATION REGISTERS, 10h - Control1) is clear. If the 12/24 bit is set, the AM/PM bit will be 0 for AM hours and 1 for PM hours, and hour values will be from 1 to 12.

Hours Alarm Register (24 Hour Mode)

| Address | Function | Bit 7 | Bit 6 | Bit 5 | Bit 4 | Bit 3 | Bit 2 | Bit 1 | Bit 0 |
|---------|-------------|----------|---|-------|-------|-------|-------|-------|-------|
| 0Bh | Hours Alarm | GP17 | GP16 | 20 | 10 | 8 | 4 | 2 | 1 |
| | Reset | 0 | 0 | 0 | 0 | 0 | 0 | 0 | 0 |
| Bit | Symbol | Value | Description | | | | | | |
| 7 | GP17 | 0 or 1 | Register bit for general purpose use. | | | | | | |
| 6 | GP16 | 0 or 1 | Register bit for general purpose use. | | | | | | |
| 5:0 | Hours Alarm | 00 to 23 | Holds the alarm value for hours, coded in BCD format. | | | | | | |

Hours Alarm Register (12 Hour Mode)

| Address | Function | Bit 7 | Bit 6 | Bit 5 | Bit 4 | Bit 3 | Bit 2 | Bit 1 | Bit 0 |
|---------|-------------|---------|---|-------|-------|-------|-------|-------|-------|
| 0Bh | Hours Alarm | GP17 | GP16 | AM/PM | 10 | 8 | 4 | 2 | 1 |
| | Reset | 0 | 0 | 0 | 0 | 0 | 0 | 0 | 0 |
| Bit | Symbol | Value | Description | | | | | | |
| 7 | GP17 | 0 or 1 | Register bit for general purpose use. | | | | | | |
| 6 | GP16 | 0 or 1 | Register bit for general purpose use. | | | | | | |
| 5 | AM/PM | 0 | AM hours. | | | | | | |
| | | 1 | PM hours. | | | | | | |
| 4:0 | Hours Alarm | 1 to 12 | Holds the alarm value for hours, coded in BCD format. | | | | | | |

0Ch - Date Alarm

This register holds the alarm value for the date, in two binary coded decimal (BCD) digits. Values will range from 01 to 31. Leap years are correctly handled from 1900 to 2199.

| Address | Function | Bit 7 | Bit 6 | Bit 5 | Bit 4 | Bit 3 | Bit 2 | Bit 1 | Bit 0 |
|---------|------------|----------|--|-------|-------|-------|-------|-------|-------|
| 0Ch | Date Alarm | GP19 | GP18 | 20 | 10 | 8 | 4 | 2 | 1 |
| | Reset | 0 | 0 | 0 | 0 | 0 | 0 | 0 | 0 |
| Bit | Symbol | Value | Description | | | | | | |
| 7 | GP19 | 0 or 1 | Register bit for general purpose use. | | | | | | |
| 6 | GP18 | 0 or 1 | Register bit for general purpose use. | | | | | | |
| 5:0 | Date Alarm | 01 to 31 | Holds the alarm value for the date, coded in BCD format. | | | | | | |

0Dh - Months Alarm

This register holds the alarm value for months, in two binary coded decimal (BCD) digits. Values will range from 01 to 12.

| Address | Function | Bit 7 | Bit 6 | Bit 5 | Bit 4 | Bit 3 | Bit 2 | Bit 1 | Bit 0 |
|---------|--------------|----------|--|-------|-------|-------|-------|-------|-------|
| 0Dh | Months Alarm | GP22 | GP21 | GP20 | 10 | 8 | 4 | 2 | 1 |
| | Reset | 0 | 0 | 0 | 0 | 0 | 0 | 0 | 0 |
| Bit | Symbol | Value | Description | | | | | | |
| 7 | GP22 | 0 or 1 | Register bit for general purpose use. | | | | | | |
| 6 | GP21 | 0 or 1 | Register bit for general purpose use. | | | | | | |
| 5 | GP20 | 0 or 1 | Register bit for general purpose use. | | | | | | |
| 4:0 | Months Alarm | 01 to 12 | Holds the alarm value for months, coded in BCD format. | | | | | | |

0Eh - Weekdays Alarm

This register holds the alarm value for the day of the week. Values will range from 0 to 6.

| Address | Function | Bit 7 | Bit 6 | Bit 5 | Bit 4 | Bit 3 | Bit 2 | Bit 1 | Bit 0 |
|---------|----------------|--------|---------------------------------------|-------|-------|-------|-------|-------|-------|
| 0Eh | Weekdays Alarm | GP27 | GP26 | GP25 | GP24 | GP23 | 4 | 2 | 1 |
| | Reset | 0 | 0 | 0 | 0 | 0 | 0 | 0 | 0 |
| Bit | Symbol | Value | Description | | | | | | |
| 7 | GP27 | 0 or 1 | Register bit for general purpose use. | | | | | | |
| 6 | GP26 | 0 or 1 | Register bit for general purpose use. | | | | | | |
| 5 | GP25 | 0 or 1 | Register bit for general purpose use. | | | | | | |
| 4 | GP24 | 0 or 1 | Register bit for general purpose use. | | | | | | |
| 3 | GP23 | 0 or 1 | Register bit for general purpose use. | | | | | | |
| 2:0 | Weekdays Alarm | 0 to 6 | Holds the weekdays alarm value. | | | | | | |

3.4. CONFIGURATION REGISTERS

0Fh – Status

This register holds a variety of status bits. The register may be written at any time to clear or set any status flag. If the ARST bit is set (see 10h - Control1), any read of the Status Register will clear interrupt flags in this register (WDF, BLF, TF, AF and EVF). The bits CB and BAT are not affected.

| Address | Function | Bit 7 | Bit 6 | Bit 5 | Bit 4 | Bit 3 | Bit 2 | Bit 1 | Bit 0 |
|---------|----------|--|--|-------|-------|-------|-------|-------|-------|
| 0Fh | Status | CB | BAT | WDF | BLF | TF | AF | EVF | X |
| | Reset | 0 | 0 | 0 | 0 | 0 | 0 | 0 | 0 |
| Bit | Symbol | Value | Description | | | | | | |
| 7 | CB | Century bit. This bit will be toggled when the Years register rolls over from 99 to 00 if the CBE bit is a 1 (see 12h - Interrupt Mask register). Assuming that the current Year is in the 20xx century the CB bit has to be set to 1. | | | | | | | |
| | | 0 | Assumes the century is 19xx or 21xx. – Default value | | | | | | |
| | | 1 | Assumes it is 20xx for leap year calculations. | | | | | | |
| 6 | BAT | (read only) – VBACKUP Power state | | | | | | | |
| | | 0 | System is in POR or VDD Power state. | | | | | | |
| | | 1 | System is in VBACKUP Power state. | | | | | | |
| 5 | WDF | Watchdog Timer Flag | | | | | | | |
| | | 0 | No Watchdog Timer timeout trigger detected. | | | | | | |
| | | 1 | The Watchdog Timer is enabled and is triggered, and the WDS bit is 0 (see TIMER REGISTERS, 1Bh Watchdog Timer). | | | | | | |
| 4 | BLF | Battery Low Flag | | | | | | | |
| | | 0 | No crossing of the reference voltage detected. | | | | | | |
| | | 1 | The battery voltage V_{BACKUP} crossed the reference voltage selected by BREF (see ANALOG CONTROL REGISTERS, 21h - BREF Control) in the direction selected by BPOL (see RAM REGISTERS, 3Fh - Extension RAM Address). | | | | | | |
| 3 | TF | Countdown Timer Flag | | | | | | | |
| | | 0 | No zero detected. | | | | | | |
| | | 1 | Countdown Timer is enabled and reaches zero. | | | | | | |
| 2 | AF | Alarm Flag | | | | | | | |
| | | 0 | No match detected. | | | | | | |
| | | 1 | The Alarm function is enabled and all selected Alarm registers match their respective counters. | | | | | | |
| 1 | EVF | External Event Flag | | | | | | | |
| | | 0 | No external trigger detected. | | | | | | |
| | | 1 | An external trigger is detected on the WDI pin. The EIE bit (see CONFIGURATION REGISTERS , 12h - Interrupt Mask) must be set in order for this interrupt to occur, but subsequently clearing EIE will not automatically clear this flag. | | | | | | |
| 0 | X | 0 | Unused flag. Always 0. | | | | | | |

10h - Control1

This register holds some major control signals.

| Address | Function | Bit 7 | Bit 6 | Bit 5 | Bit 4 | Bit 3 | Bit 2 | Bit 1 | Bit 0 |
|---------|----------|--|---|-------|-------|-------|-------|-------|-------|
| 10h | Control1 | STOP | 12/24 | PSWB | CLKB | RSTP | ARST | PSWC | WRTC |
| | Reset | 0 | 0 | 0 | 1 | 0 | 0 | 1 | 1 |
| Bit | Symbol | Value | Description | | | | | | |
| 7 | STOP | 0 | The clocking system is not stopped. | | | | | | |
| | | 1 | Stops the clocking system. The XT and RC Oscillators are not stopped. In XT Mode the 32.768 kHz clock output will continue to run. In RC Mode, the RC clock output will continue to run. Other clock output selections will produce static outputs. This bit allows the clock system to be precisely started, by setting it to 1 and back to 0. | | | | | | |
| 6 | 12/24 | 0 | The Hours register operates in 24 hour mode. | | | | | | |
| | | 1 | The Hours register operates in 12 hour mode. | | | | | | |
| 5 | PSWB | 0 or 1 | A static bit value which may be driven on the PSW pin. The PSWB bit cannot be set to 1 if the LKP bit is 1 (see OSCILLATOR REGISTERS, 1Dh – Oscillator Status). | | | | | | |
| 4 | CLKB | 0 or 1 | A static bit value which may be driven on the CLK / $\overline{\text{INT}}$ pin. This bit also defines the default value for the square wave signal SQW when SQWE is not asserted high. The default value of CLKB is 1 (high impedance). | | | | | | |
| 3 | RSTP | RST Pin Polarity | | | | | | | |
| | | 0 | The $\overline{\text{RST}}$ pin is asserted low. | | | | | | |
| | | 1 | The $\overline{\text{RST}}$ pin is asserted high. | | | | | | |
| 2 | ARST | Auto reset enable (Interrupt flags in Status register) | | | | | | | |
| | | 0 | The interrupt flags must be explicitly cleared by writing the Status register. | | | | | | |
| | | 1 | A read of the Status register will cause the interrupt flags in the Status register to be cleared (WDF, BLF, TF, AF, EVF). | | | | | | |
| 1 | PSWC | PSW Pin Control (1 Ω / normal) | | | | | | | |
| | | 0 | The PSW pin is a normal open drain output. | | | | | | |
| | | 1 | The PSW pin is driven by an approximately 1 Ω pull-down which allows the RV-1805-C3 to switch power to other system devices through this pin. | | | | | | |
| 0 | WRTC | Write RTC | | | | | | | |
| | | 0 | Prevents inadvertent software access to the Counters. | | | | | | |
| | | 1 | In order to write to any of the Counter registers (Hundredths, Seconds, Minutes, Hours, Date, Months, Years or Weekdays). | | | | | | |

11h - Control2

This register holds additional control and configuration signals for the flexible output pins CLK/ $\overline{\text{INT}}$ and PSW. Note that PSW and CLK/ $\overline{\text{INT}}$ are open drain outputs.

| Address | Function | Bit 7 | Bit 6 | Bit 5 | Bit 4 | Bit 3 | Bit 2 | Bit 1 | Bit 0 |
|---------|------------|--|---|-------|-------|-------|-------|-------|-------|
| 11h | Control2 | RESERVED | | X | PSWS | | | CLKS | |
| | Reset | 0 | 0 | 1 | 1 | 1 | 1 | 0 | 0 |
| | Set X to 0 | | | 0 | | | | | |
| Bit | Symbol | Value | Description | | | | | | |
| 7:6 | RESERVED | 00 to 11 | RESERVED | | | | | | |
| 5 | X | 0 or 1 | Unused, but has to be 0 to avoid extraneous leakage. | | | | | | |
| 4:2 | PSWS | PSW Pin Function Selection | | | | | | | |
| | | 000 | Inverse of the combined interrupt signal IRQ if at least one interrupt is enabled, else static PSWB | | | | | | |
| | | 001 | SQW if SQWE = 1, else static PSWB | | | | | | |
| | | 010 | RESERVED | | | | | | |
| | | 011 | Inverse AIRQ if AIE is set, else static PSWB | | | | | | |
| | | 100 | TIRQ if TIE is set, else static PSWB | | | | | | |
| | | 101 | Inverse TIRQ if TIE is set, else static PSWB | | | | | | |
| | | 110 | SLEEP signal | | | | | | |
| 1:0 | CLKS | CLK / $\overline{\text{INT}}$ Pin Function Selection | | | | | | | |
| | | 00 | Inverse of the combined interrupt signal IRQ if at least one interrupt is enabled, else static CLKB | | | | | | |
| | | 01 | SQW if SQWE = 1, else static CLKB | | | | | | |
| | | 10 | SQW if SQWE = 1, else inverse of the combined interrupt signal IRQ if at least one interrupt is enabled, else static CLKB | | | | | | |
| | | 11 | Inverse AIRQ if AIE is set, else static CLKB | | | | | | |

12h - Interrupt Mask

This register holds the interrupt enable bits and other configuration information.

| Address | Function | Bit 7 | Bit 6 | Bit 5 | Bit 4 | Bit 3 | Bit 2 | Bit 1 | Bit 0 |
|---------|----------------|--|---|-------|-------|-------|-------|-------|-------|
| 12h | Interrupt Mask | CBE | IM | | BLIE | TIE | AIE | EIE | X |
| | Reset | 1 | 1 | 1 | 0 | 0 | 0 | 0 | 0 |
| Bit | Symbol | Value | Description | | | | | | |
| 7 | CBE | Century Bit Enable | | | | | | | |
| | | 0 | The CB bit will never be automatically updated. | | | | | | |
| | | 1 | The CB bit will toggle when the Years register rolls over from 99 to 00. | | | | | | |
| 6:5 | IM | Alarm Interrupt Mode. This controls the duration of the Inverse AIRQ interrupt as shown below. The interrupt output always goes high when the corresponding flag in the Status Register is cleared. In order to minimize current drawn by the RV-1805-C3 this field should be kept at 3h. | | | | | | | |
| | | 00 | Level (static) for both XT mode and RC mode. | | | | | | |
| | | 01 | 1/8192 seconds for XT mode. 1/64 seconds for RC mode. | | | | | | |
| | | 10 | 1/64 seconds for both XT mode and RC mode. | | | | | | |
| | | 11 | 1/4 seconds for both XT mode and RC mode. – Default value | | | | | | |
| 4 | BLIE | Battery Low Interrupt Enable | | | | | | | |
| | | 0 | Disables the battery low interrupt. | | | | | | |
| | | 1 | The battery low detection will generate an interrupt BLIRQ. | | | | | | |
| 3 | TIE | Timer Interrupt Enable | | | | | | | |
| | | 0 | Disables the timer interrupt. | | | | | | |
| | | 1 | The Countdown Timer will generate a TIRQ interrupt signal and set the TF flag when the timer reaches 0. | | | | | | |
| 2 | AIE | Alarm Interrupt Enable | | | | | | | |
| | | 0 | Disables the alarm interrupt. | | | | | | |
| | | 1 | A match of all the enabled alarm registers will generate an AIRQ interrupt signal. | | | | | | |
| 1 | EIE | External Interrupt Enable | | | | | | | |
| | | 0 | Disables the external interrupt. | | | | | | |
| | | 1 | The WDI input pin will generate an external interrupt EIRQ when the edge specified by EIP occurs (see CONFIGURATION REGISTERS, 12h - Interrupt Mask). | | | | | | |
| 0 | X | 0 | Unused, but has to be 0 to avoid extraneous leakage. | | | | | | |

13h – Square Wave SQW

This register holds the control for the square wave signal SQW. Note that some frequency selections are not valid if the RC Oscillator is selected.

| Address | Function | Bit 7 | Bit 6 | Bit 5 | Bit 4 | Bit 3 | Bit 2 | Bit 1 | Bit 0 |
|--|---|--------------------------------------|--|-------|-------|-------|-------|-------|-------|
| 13h | Square Wave SQW | SQWE | RESERVED | | SQWS | | | | |
| | Reset | 0 | 0 | 1 | 0 | 0 | 1 | 1 | 0 |
| Bit | Symbol | Value | Description | | | | | | |
| 7 | SQWE | Square Wave enable (internal SQW) | | | | | | | |
| | | 0 | The square wave signal SQW is held at the static value of CLKB. | | | | | | |
| | | 1 | The square wave signal SQW is enabled. | | | | | | |
| 6:5 | RESERVED | 00 to 11 | RESERVED | | | | | | |
| 4:0 | SQWS | Square Wave selection (internal SQW) | | | | | | | |
| | | 00000 to 11111 | Selects the frequency of the square wave signal SQW, as shown in the following table. Note that some selections are not valid if the RC oscillator is selected. Some selections also produce short pulses rather than square waves, and are intended primarily for test usage. | | | | | | |
| SQWS | | Square Wave Signal SQW Select | | | | | | | |
| 00000 | 1 century ⁽²⁾ | | | | | | | | |
| 00001 | 32.768 kHz ⁽¹⁾ | | | | | | | | |
| 00010 | 8.192 kHz ⁽¹⁾ | | | | | | | | |
| 00011 | 4.096 kHz ⁽¹⁾ | | | | | | | | |
| 00100 | 2.048 kHz ⁽¹⁾ | | | | | | | | |
| 00101 | 1.024 kHz ⁽¹⁾ | | | | | | | | |
| 00110 | 512 Hz ⁽¹⁾ – Default value | | | | | | | | |
| 00111 | 256 Hz ⁽¹⁾ | | | | | | | | |
| 01000 | 128 Hz ⁽³⁾ | | | | | | | | |
| 01001 | 64 Hz – highest calibrated frequency in RC mode | | | | | | | | |
| 01010 | 32 Hz | | | | | | | | |
| 01011 | 16 Hz | | | | | | | | |
| 01100 | 8 Hz | | | | | | | | |
| 01101 | 4 Hz | | | | | | | | |
| 01110 | 2 Hz | | | | | | | | |
| 01111 | 1 Hz | | | | | | | | |
| 10000 | ½ Hz | | | | | | | | |
| 10001 | ¼ Hz | | | | | | | | |
| 10010 | 1/8 Hz | | | | | | | | |
| 10011 | 1/16 Hz | | | | | | | | |
| 10100 | 1/32 Hz | | | | | | | | |
| 10101 | 1/60 Hz (1 minute) | | | | | | | | |
| 10110 | 16.384 kHz ⁽¹⁾ – highest calibrated frequency in XT mode | | | | | | | | |
| 10111 | 100 Hz ⁽¹⁾⁽²⁾ | | | | | | | | |
| 11000 | 1 hour ⁽²⁾ | | | | | | | | |
| 11001 | 1 day ⁽²⁾ | | | | | | | | |
| 11010 | TIRQ | | | | | | | | |
| 11011 | Inverse TIRQ | | | | | | | | |
| 11100 | 1 year ⁽²⁾ | | | | | | | | |
| 11101 | 1 Hz to Counters ⁽²⁾ | | | | | | | | |
| 11110 | 1/32 Hz from Autocalibration ⁽²⁾ | | | | | | | | |
| 11111 | 1/8 Hz from Autocalibration ⁽²⁾ | | | | | | | | |
| ⁽¹⁾ Not applicable if the RC Oscillator is selected. ⁽²⁾ Pulses for Test Usage. ⁽³⁾ If the RC Oscillator is selected the frequency is typically 122 Hz. | | | | | | | | | |

3.5. CALIBRATION REGISTERS

14h - Calibration XT

This register holds the control signals for the digital calibration function of the XT Oscillator. This register is initialized with a factory value which calibrates the XT Oscillator. The highest modified frequency is 16.384 kHz (see XT OSCILLATOR DIGITAL CALIBRATION).

| Address | Function | Bit 7 | Bit 6 | Bit 5 | Bit 4 | Bit 3 | Bit 2 | Bit 1 | Bit 0 |
|------------------|----------------|----------------------------|--|----------|-------|-------|-------|-------|-------|
| 14h | Calibration XT | CMDX | OFFSETX | | | | | | |
| | Reset | 0 | Preconfigured (Factory Calibrated) | | | | | | |
| Bit | Symbol | Value | Description | | | | | | |
| 7 | CMDX | XT calibration adjust mode | | | | | | | |
| | | 0 | Normal Mode, each adjustment step is ± 2 ppm. The calibration period is 32 seconds. | | | | | | |
| | | 1 | Coarse Mode, each adjustment step is ± 4 ppm. The calibration period is 16 seconds. | | | | | | |
| 6:0 | OFFSETX | -64 to +63 | The amount to adjust the effective time. This is a two's complement number with a range of -64 to +63 adjustment steps (Factory Calibrated). | | | | | | |
| OFFSETX (7 Bits) | Unsigned value | Two's complement | Correction value in ppm ^(*) | | | | | | |
| | | | CMDX = 0 | CMDX = 1 | | | | | |
| 011'1111 | 63 | 63 | 120.163 | 240.326 | | | | | |
| 011'1110 | 62 | 62 | 118.256 | 236.511 | | | | | |
| : | : | : | : | : | | | | | |
| 000'0001 | 1 | 1 | 1.907 | 3.815 | | | | | |
| 000'0000 | 0 | 0 | 0.000 | 0.000 | | | | | |
| 111'1111 | 127 | -1 | -1.907 | -3.815 | | | | | |
| 111'1110 | 126 | -2 | -3.815 | -7.629 | | | | | |
| : | : | : | : | : | | | | | |
| 100'0001 | 65 | -63 | -120.163 | -240.326 | | | | | |
| 100'0000 | 64 | -64 | -122.070 | -244.141 | | | | | |

(*) Calculated with 5 decimal places ($1'000'000/2^{19} = 1.90735$ ppm)

15h - Calibration RC Upper

This register holds the control signals for the fine digital calibration function of the low power RC Oscillator. This register is initialized with a factory value which calibrates the RC Oscillator. The highest modified frequency is 64 Hz (see RC OSCILLATOR DIGITAL CALIBRATION).

| Address | Function | Bit 7 | Bit 6 | Bit 5 | Bit 4 | Bit 3 | Bit 2 | Bit 1 | Bit 0 | |
|---------|----------------------|-------------------------|--|--------------------|------------------------------------|-------|-------|-------|-------|--|
| 15h | Calibration RC Upper | CMDR | | | OFFSETRU | | | | | |
| | Reset | Preconfigured | | | Preconfigured (Factory Calibrated) | | | | | |
| Bit | Symbol | Value | Description | | | | | | | |
| 7:6 | CMDR | 00 to 11 | The calibration adjust mode for the RC calibration adjustment. CMDR selects the highest possible calibration period used in the RC Calibration process as shown in the following table. | | | | | | | |
| 5:0 | OFFSETRU | 000000 to 111111 | The upper 6 bits of the OFFSETR field, which is used to set the amount to adjust the effective time. OFFSETR is a two's complement number with a range of -2^{13} to $+2^{13}-1$ adjustment steps (Factory Calibrated). See Table 1. | | | | | | | |
| CMDR | Calibration Period | Minimal Adjustment Step | | Maximum Adjustment | | | | | | |
| 00 | 8'192 seconds | +/-1.91 ppm | | +/-1.56% | | | | | | |
| 01 | 4'096 seconds | +/-3.82 ppm | | +/-3.13% | | | | | | |
| 10 | 2'048 seconds | +/-7.63 ppm | | +/-6.25% | | | | | | |
| 11 | 1'024 seconds | +/-15.26 ppm | | +/-12.5% | | | | | | |

16h - Calibration RC Lower

This register holds the lower 8 bits of the OFFSETR field for the digital calibration function of the low power RC Oscillator. This register is initialized with a factory value which calibrates the RC Oscillator. The highest modified frequency is 64 Hz (see RC OSCILLATOR DIGITAL CALIBRATION).

| Address | Function | Bit 7 | Bit 6 | Bit 5 | Bit 4 | Bit 3 | Bit 2 | Bit 1 | Bit 0 |
|---------|----------------------|------------------------------------|--|-------|-------|-------|-------|-------|-------|
| 16h | Calibration RC Lower | OFFSETRL | | | | | | | |
| | Reset | Preconfigured (Factory Calibrated) | | | | | | | |
| Bit | Symbol | Value | Description | | | | | | |
| 7:0 | OFFSETRL | 00h to FFh | The lower 8 bits of the OFFSETR field, which is used to set the amount to adjust the effective time. OFFSETR is a two's complement number with a range of -2^{13} to $+2^{13}-1$ adjustment steps (Factory Calibrated). See Table 1. | | | | | | |

Table 1: Calibration RC

| OFFSETR (14 Bits) | Unsigned value | Two's complement | Correction value in ppm ^(*) | | | |
|-------------------|----------------|------------------|--|-----------|-----------|-----------|
| | | | CMDR = 00 | CMDR = 01 | CMDR = 10 | CMDR = 11 |
| 01'1111'1111'1111 | 8191 | 8191 | 15623 | 31246 | 62492 | 124985 |
| 01'1111'1111'1110 | 8190 | 8190 | 15621 | 31242 | 62485 | 124970 |
| : | : | : | : | : | : | : |
| 00'0000'0000'0001 | 1 | 1 | 1.907 | 3.815 | 7.629 | 15.259 |
| 00'0000'0000'0000 | 0 | 0 | 0.000 | 0.000 | 0.000 | 0.000 |
| 11'1111'1111'1111 | 16383 | -1 | -1.907 | -3.815 | -7.629 | -15.259 |
| 11'1111'1111'1110 | 16382 | -2 | -3.815 | -7.629 | -15.259 | -30.518 |
| : | : | : | : | : | : | : |
| 10'0000'0000'0001 | 8193 | -8191 | -15623 | -31246 | -62492 | -124985 |
| 10'0000'0000'0000 | 8192 | -8192 | -15625 | -31250 | -62500 | -125000 |

^(*) Calculated with 5 decimal places ($1'000'000/2^{19} = 1.90735$ ppm)

3.6. SLEEP CONTROL REGISTER

17h - Sleep Control

This register controls the Sleep function of the Power Control system.

| Address | Function | Bit 7 | Bit 6 | Bit 5 | Bit 4 | Bit 3 | Bit 2 | Bit 1 | Bit 0 |
|---------|---------------|---|--|--|-------|-------|-------|-------|-------|
| 17h | Sleep Control | SLP | SLRST | EIP | X | SLF | SLW | | |
| | Reset | 0 | 0 | 0 | 0 | 0 | 0 | 0 | 0 |
| Bit | Symbol | Value | Description | | | | | | |
| 7 | SLP | Sleep Request signal, see also SLEEP CONTROL STATE MACHINE | | | | | | | |
| | | 0 | The Sleep Control State Machine is in RUN mode. If either STOP is 1 or no interrupt is enabled, SLP will remain at 0 even after an attempt to set it to 1. | | | | | | |
| | | 1 | When set to 1, the Sleep Control State Machine will transition to the SWAIT state as long as a valid interrupt is enabled. This bit will be cleared when the Sleep Control State Machine returns to the RUN state. | | | | | | |
| 6 | SLRST | Reset $\overline{\text{RST}}$ when in SLEEP mode | | | | | | | |
| | | 0 | $\overline{\text{RST}}$ does not indicate the SLEEP state. | | | | | | |
| | | 1 | Asserts $\overline{\text{RST}}$ low when the Sleep Control State Machine is in the SLEEP state. | | | | | | |
| 5 | EIP | External Interrupt polarity | | | | | | | |
| | | 0 | The external interrupt will trigger on a falling edge of the WDI pin. | | | | | | |
| | | 1 | The external interrupt will trigger on a rising edge of the WDI pin. | | | | | | |
| 4 | X | 0 | Unused, but has to be 0 to avoid extraneous leakage. | | | | | | |
| 3 | SLF | Sleep Flag | | | | | | | |
| | | 0 | No previous SLEEP state occurred. | | | | | | |
| | | 1 | Flag is set when the RV-1805-C3 enters Sleep Mode. This allows software to determine if a SLEEP has occurred since the last time this bit was read. | | | | | | |
| 2:0 | SLW | Sleep Wait periods. The number of ~8 ms waiting periods after SLP is set until the Sleep Control State Machine goes into the SLEEP state. If SLW is not 0, the actual delay is guaranteed to be between SLW and (SLW + 1) periods. | | | | | | | |
| | | SLW | | Wait time | | | | | |
| | | 000 | 0 | The transition will occur with no delay. | | | | | |
| | | 001 | 1 | 8 to 16 ms | | | | | |
| | | 010 | 2 | 16 to 24 ms | | | | | |
| | | 011 | 3 | 24 to 32 ms | | | | | |
| | | 100 | 4 | 32 to 40 ms | | | | | |
| | | 101 | 5 | 40 to 48 ms | | | | | |
| | | 110 | 6 | 48 to 56 ms | | | | | |
| 111 | 7 | 56 to 64 ms | | | | | | | |

3.7. TIMER REGISTERS

18h - Countdown Timer Control

This register controls the Countdown Timer function. Note that the TFS = 00 frequency selection is slightly different depending on whether the 32.768 kHz XT Oscillator or the RC Oscillator is selected. In some RC Oscillator modes, the interrupt pulse output is specified as RC Pulse. In these cases the interrupt output will be a short negative going pulse which is typically between 100 and 400 μ s. This allows control of external devices which require pulses shorter than the minimum 7.8 ms pulse created directly by the RC Oscillator.

| Address | Function | Bit 7 | Bit 6 | Bit 5 | Bit 4 | Bit 3 | Bit 2 | Bit 1 | Bit 0 |
|--|---------------------------------------|--|--|-------|-------|-------|-------|-------|-------|
| 18h | Countdown Timer Control | TE | TM | TRPT | ARPT | | | TFS | |
| | Reset | 0 | 0 | 1 | 0 | 0 | 0 | 1 | 1 |
| Bit | Symbol | Value | Description | | | | | | |
| 7 | TE | Timer Enable | | | | | | | |
| | | 0 | The Countdown Timer retains the current value. The clock to the Timer is disabled for power minimization. | | | | | | |
| | | 1 | The Countdown Timer will count down. | | | | | | |
| 6 | TM | Timer Mode. Along with TRPT, this controls the Countdown Timer Interrupt function as shown in Table 2. A Pulse interrupt will cause the inverse of the combined interrupt signal IRQ signal to be driven low for the time shown in Table 2 or until the flag is cleared. A Level Interrupt will cause the inverse of the combined interrupt signal IRQ signal to be driven low by a Countdown Timer interrupt until the associated flag is cleared. | | | | | | | |
| | | 0 | Pulse (TRPT is 0 or 1) | | | | | | |
| | | 1 | Level if TRPT = 0. Pulse if TRPT = 1. | | | | | | |
| 5 | TRPT | Timer Repeat. Along with TM, this controls the Countdown Timer Interrupt function as shown in Table 2. | | | | | | | |
| | | 0 | Single is selected. The Countdown Timer will halt when it reaches zero. If TM = 0, it allows the generation of periodic interrupts of virtually any frequency. If TM = 1, it is a Level. | | | | | | |
| | | 1 | Repeat is selected. The Countdown Timer reloads the value from the Timer Initial register upon reaching 0, and continues counting. | | | | | | |
| 4:2 | ARPT | Alarm Repeat | | | | | | | |
| | | 0 to 7 | These bits enable the Alarm Interrupt repeat function together with the Hundredths Alarm register value, as shown in the following table. | | | | | | |
| 1:0 | TFS | Timer Frequency Selection | | | | | | | |
| | | 00 to 11 | Select the clock frequency and interrupt pulse width of the Countdown Timer, as defined in Table 2. The RC Pulse is a short negative going 100-400 μ s pulse. | | | | | | |
| ARPT | 08h - Hundredths Alarm register value | Repeat When | | | | | | | |
| 7 | FFh | Once per hundredth (100 Hz) ⁽¹⁾ | | | | | | | |
| | F0h to F9h | Once per tenth (10 Hz) ⁽¹⁾ | | | | | | | |
| 6 | 00 to 99 | Hundredths match (once per second) ⁽²⁾ | | | | | | | |
| 5 | | Hundredths and seconds match (once per minute) ⁽²⁾ | | | | | | | |
| 4 | | Hundredths, seconds and minutes match (once per hour) ⁽²⁾ | | | | | | | |
| 3 | | Hundredths, seconds, minutes and hours match (once per day) ⁽²⁾ | | | | | | | |
| 2 | | Hundredths, seconds, minutes, hours and weekday match (once per week) ⁽²⁾ | | | | | | | |
| 1 | | Hundredths, seconds, minutes, hours and date match (once per month) ⁽²⁾ | | | | | | | |
| | | Hundredths, seconds, minutes, hours, date and month match (once per year) ⁽²⁾ | | | | | | | |
| 0 | | Alarm Disabled | | | | | | | |
| ⁽¹⁾ Once per second if RC Oscillator selected. ⁽²⁾ The Hundredths are not valid if the RC Oscillator is selected. | | | | | | | | | |

Table 2: Countdown Timer Function Select

| TM | TRPT | TFS | Interrupt signal | | Countdown Timer Frequency | | Interrupt Pulse Width | |
|----|------|-----|------------------|-------------------|---------------------------|---------------|-----------------------|---------------|
| | | | Pulse/ Level | Single/ Repeat | XT Oscillator | RC Oscillator | XT Oscillator | RC Oscillator |
| 0 | 0 | 00 | Pulse | Single | 4096 Hz | Typ. 122 Hz | 1/4096 s | Typ. 1/122 s |
| 0 | 0 | 01 | Pulse | Single | 64 Hz | 64 Hz | 1/128 s | Typ. 1/122 s |
| 0 | 0 | 10 | Pulse | Single | 1 Hz | 1 Hz | 1/64 s | 1/64 s |
| 0 | 0 | 11 | Pulse | Single | 1/60 Hz | 1/60 Hz | 1/64 s | 1/64 s |
| 0 | 1 | 00 | Pulse | Repeat | 4096 Hz | Typ. 122 Hz | 1/4096 s | Typ. 1/122 s |
| 0 | 1 | 01 | Pulse | Repeat | 64 Hz | 64 Hz | 1/128 s | Typ. 1/122 s |
| 0 | 1 | 10 | Pulse | Repeat | 1 Hz | 1 Hz | 1/64 s | 1/64 s |
| 0 | 1 | 11 | Pulse | Repeat | 1/60 Hz | 1/60 Hz | 1/64 s | 1/64 s |
| 1 | 0 | 00 | Level | Single | 4096 Hz | Typ. 122 Hz | - | - |
| 1 | 0 | 01 | Level | Single | 64 Hz | 64 Hz | - | - |
| 1 | 0 | 10 | Level | Single | 1 Hz | 1 Hz | - | - |
| 1 | 0 | 11 | Level | Single | 1/60 Hz | 1/60 Hz | - | - |
| 1 | 1 | 00 | Pulse | Repeat | 4096 Hz | Typ. 122 Hz | 1/4096 s | RC Pulse |
| 1 | 1 | 01 | Pulse | Repeat | 64 Hz | 64 Hz | 1/4096 s | RC Pulse |
| 1 | 1 | 10 | Pulse | Repeat | 1 Hz | 1 Hz | 1/4096 s | RC Pulse |
| 1 | 1 | 11 | Pulse | Repeat | 1/60 Hz | 1/60 Hz | 1/4096 s | RC Pulse |

19h - Countdown Timer

This register holds the current value of the Countdown Timer. It may be loaded with the desired starting value when the Countdown Timer is stopped.

| Address | Function | Bit 7 | Bit 6 | Bit 5 | Bit 4 | Bit 3 | Bit 2 | Bit 1 | Bit 0 |
|---------|-----------------|----------|--|-------|-------|-------|-------|-------|-------|
| 19h | Countdown Timer | 128 | 64 | 32 | 16 | 8 | 4 | 2 | 1 |
| | Reset | 0 | 0 | 0 | 0 | 0 | 0 | 0 | 0 |
| Bit | Symbol | Value | Description | | | | | | |
| 7:0 | Countdown Timer | 0 to 255 | The current value of the Countdown Timer in binary format. | | | | | | |

1Ah - Timer Initial Value

This register holds the value which will be reloaded into the Countdown Timer when it reaches zero if the TRPT bit is a 1. This allows for periodic timer interrupts (see calculation below).

| Address | Function | Bit 7 | Bit 6 | Bit 5 | Bit 4 | Bit 3 | Bit 2 | Bit 1 | Bit 0 |
|---------|---------------------|----------|---|-------|-------|-------|-------|-------|-------|
| 1Ah | Timer Initial Value | 128 | 64 | 32 | 16 | 8 | 4 | 2 | 1 |
| | Reset | 0 | 0 | 0 | 0 | 0 | 0 | 0 | 0 |
| Bit | Symbol | Value | Description | | | | | | |
| 7:0 | Timer Initial Value | 0 to 255 | The value in binary format reloaded into the Countdown Timer when it reaches zero if the TRPT bit is a 1. | | | | | | |

Calculation of the period:

$$\text{period} = (\text{Timer Initial Value} + 1) \frac{1}{\text{Countdown Timer Frequency}}$$

Example: For a period of 4 minutes (240 seconds) and with a Countdown Timer Frequency of 1 Hz (TFS = 10) a Timer Initial Value of 239 is needed:

$$\text{period} = (239 + 1) \frac{1}{1 \text{ Hz}} = \underline{\underline{240 \text{ seconds}}}$$

1Bh - Watchdog Timer

This register controls the Watchdog Timer function.

| Address | Function | Bit 7 | Bit 6 | Bit 5 | Bit 4 | Bit 3 | Bit 2 | Bit 1 | Bit 0 | |
|---------|----------------|---------------------------------|--|-------|-------------------|-------|-------|-------|-------|--|
| 1Bh | Watchdog Timer | WDS | WDM | | | | | WD | | |
| | Reset | 0 | 0 | 0 | 0 | 0 | 0 | 0 | 0 | |
| Bit | Symbol | Value | Description | | | | | | | |
| 7 | WDS | Watchdog Timer Steering | | | | | | | | |
| | | 0 | The Watchdog Timer will generate a WIRQ interrupt signal and sets the WDF flag to 1 when it times out. | | | | | | | |
| | | 1 | The Watchdog Timer will generate a Reset \overline{RST} when it times out. \overline{RST} pin is asserted low within 1/16 second of the timer reaching zero and remains asserted low for 1/16 second. The WDF flag is not set. | | | | | | | |
| 6:2 | WDM | Watchdog Timer cycle multiplier | | | | | | | | |
| | | 0 | Disables the Watchdog Timer function. | | | | | | | |
| | | 1 to 31 | Watchdog Multiplier value. The number of clock cycles which must occur before the Watchdog Timer times out. See table below. | | | | | | | |
| 1:0 | WD | Watchdog Timer clock frequency | | | | | | | | |
| | | 00 | 16 Hz | | | | | | | |
| | | 01 | 4 Hz | | | | | | | |
| | | 10 | 1 Hz | | | | | | | |
| | | 11 | 1/4 Hz | | | | | | | |
| WD | Clock Period | WDM | | | Timeout | | | | | |
| 00 | 62.5 ms | 1 to 31 | | | 62.5 to 1937.5 ms | | | | | |
| 01 | 250 ms | 1 to 31 | | | 250 to 7750 ms | | | | | |
| 10 | 1 second | 1 to 31 | | | 1 to 31 seconds | | | | | |
| 11 | 4 seconds | 1 to 31 | | | 4 to 124 seconds | | | | | |

3.8. OSCILLATOR REGISTERS

1Ch - Oscillator Control

This register controls the overall Oscillator function. It may only be written if the Configuration Key register value CONFKEY contains the value A1h. An Autocalibration cycle is initiated immediately whenever this register is written with a value in the ACAL field which is not zero.

| Address | Function | Bit 7 | Bit 6 | Bit 5 | Bit 4 | Bit 3 | Bit 2 | Bit 1 | Bit 0 |
|---------|--------------------|---|--|-------|-------|-------|-------|-------|-------|
| 1Ch | Oscillator Control | OSEL | ACAL | | BOS | FOS | IOPW | OFIE | ACIE |
| | Reset | 0 | 0 | 0 | 0 | 0 | 0 | 0 | 0 |
| Bit | Symbol | Value | Description | | | | | | |
| 7 | OSEL | Oscillator Selection | | | | | | | |
| | | 0 | Request the XT Oscillator to generate a 32.768 kHz clock to the timer circuit. Note that if the XT Oscillator is not operating, the oscillator switch will not occur. The OMODE field (see OSCILLATOR REGISTERS, 1Dh – Oscillator Status) indicates the actual oscillator which is selected. | | | | | | |
| | | 1 | Request the RC Oscillator to generate the clock for the timer circuits (nominal 128 Hz). | | | | | | |
| 6:5 | ACAL | Autocalibration Mode. Controls the automatic calibration function (see AUTOCALIBRATION FREQUENCY AND CONTROL). | | | | | | | |
| | | 00 | No Autocalibration | | | | | | |
| | | 01 | RESERVED | | | | | | |
| | | 10 | Autocalibrate every 1024 seconds (~17minutes) | | | | | | |
| | | 11 | Autocalibrate every 512 seconds (~8.5 minutes) | | | | | | |
| 4 | BOS | Oscillator switch when VBACKUP | | | | | | | |
| | | 0 | No automatic oscillator switching occurs. | | | | | | |
| | | 1 | The oscillator will automatically switch to the RC oscillator (Autocalibration Mode according to the ACAL field) when the system is powered from the battery (VBACKUP Power state). | | | | | | |
| 3 | FOS | Oscillator switch when XT oscillator failure | | | | | | | |
| | | 0 | No automatic oscillator switching occurs. | | | | | | |
| | | 1 | The oscillator will automatically switch to the RC oscillator (Autocalibration Mode according to the ACAL field) when an XT oscillator failure is detected. | | | | | | |
| 2 | IOPW | I ² C in function of the PSW pin configuration and setting | | | | | | | |
| | | 0 | The I ² C interface remains enabled independent of the PSW control bits PSWC and PSWS. | | | | | | |
| | | 1 | The I ² C interface will be disabled when the PSW pin is configured as the low resistance power switch (PSWC = 1) and set to open (PSW pin = 1, high impedance). In order for the I ² C interface to be disabled, the PSW pin must be configured for the sleep function by setting the PSWS field to a value of 6. This insures that a powered down I ² C master (i.e., the host controller) does not corrupt the RV-1805-C3. | | | | | | |
| 1 | OFIE | XT Oscillator Failure Interrupt Enable | | | | | | | |
| | | 0 | Disables the XT oscillator failure interrupt. | | | | | | |
| | | 1 | An XT Oscillator Failure will generate an OFIRQ interrupt signal. | | | | | | |
| 0 | ACIE | Autocalibration Failure Interrupt Enable | | | | | | | |
| | | 0 | Disables the Autocalibration Failure Interrupt | | | | | | |
| | | 1 | An Autocalibration Failure will generate an ACIRQ interrupt signal. | | | | | | |

1Dh – Oscillator Status Register

This register holds several miscellaneous bits used to control and observe the oscillators.

| Address | Function | Bit 7 | Bit 6 | Bit 5 | Bit 4 | Bit 3 | Bit 2 | Bit 1 | Bit 0 | |
|---------|----------------------------|---|---|---|-------|----------|-------|-------|-------|--|
| 1Dh | Oscillator Status Register | XTCAL | | LKP | OMODE | RESERVED | | OF | ACF | |
| | Reset | 0 | 0 | 1 | 0 | 0 | 0 | 1 | 0 | |
| Bit | Symbol | Value | Description | | | | | | | |
| 7:6 | XTCAL | Extended Crystal Calibration. This field defines the compensation of a higher XT oscillator frequency, independent of the normal Crystal Calibration function controlled by the Calibration XT Register. The frequency generated by the Crystal Oscillator is slowed by 122 ppm times the value in the XTCAL field. Normally, this field remains 00. | | | | | | | | |
| | | 00 | 0 ppm | | | | | | | |
| | | 01 | -122 ppm | | | | | | | |
| | | 10 | -244 ppm | | | | | | | |
| | | 11 | -366 ppm | | | | | | | |
| 5 | LKP | Locking of the PSW pin | | | | | | | | |
| | | 0 | PSW pin is not locked. | | | | | | | |
| 4 | OMODE | 1 | (read only) – Oscillator Mode. If the STOP bit is set, the OMODE bit is invalid. | | | | | | | |
| | | | 0 | The XT Oscillator is selected to drive the internal clocks. | | | | | | |
| | | | 1 | The RC Oscillator is selected to drive the internal clocks. | | | | | | |
| 3:2 | RESERVED | 00 to 11 | RESERVED | | | | | | | |
| 1 | OF | XT Oscillator Failure | | | | | | | | |
| | | 0 | No XT oscillator failure has occurred. | | | | | | | |
| 1 | OF | 1 | XT Oscillator Failure. This bit is set on a power on reset (POR), when both the system and battery voltages have dropped below acceptable levels. It is also set if an XT Oscillator Failure occurs, indicating that the crystal oscillator is running at less than 8 kHz. It can be cleared by writing a 0 to the bit. | | | | | | | |
| | | Autocalibration Failure | | | | | | | | |
| 0 | ACF | 0 | No autocalibration failure has occurred. | | | | | | | |
| | | 1 | Set when an Autocalibration Failure occurs, indicating that either the RC Oscillator frequency is too different from 128 Hz to be correctly calibrated or the XT Oscillator did not start. | | | | | | | |

3.9. MISCELLANEOUS REGISTERS**1Fh - Configuration Key**

This register contains the Configuration Key CONFKEY, which must be written with specific values in order to access some registers and functions. CONFKEY is reset to 00h on any register write.

| Address | Function | Bit 7 | Bit 6 | Bit 5 | Bit 4 | Bit 3 | Bit 2 | Bit 1 | Bit 0 |
|---------|-------------------|---|---|-------|-------|-------|-------|-------|-------|
| 1Fh | Configuration Key | CONFKEY | | | | | | | |
| | Reset | 0 | 0 | 0 | 0 | 0 | 0 | 0 | 0 |
| Bit | Symbol | Value | Description | | | | | | |
| 7:0 | CONFKEY | Configuration Key. Written with specific values in order to access some registers and functions. | | | | | | | |
| | | A1h | Writing a value of A1h enables write access to the Oscillator Control register. | | | | | | |
| | | 3Ch | Writing a value of 3Ch does not update the CONFKEY value, but generates a Software Reset (see SOFTWARE RESET). | | | | | | |
| | | 9Dh | Writing a value of 9Dh enables write access to the Trickle Charge Register (20h), the BREF Register (21h), the CAPRC Register (26h), the IO Batmode Register (27h) and the Output Control Register (30h). | | | | | | |
| | | 00h | CONFKEY is reset to 00h on any register write. | | | | | | |

3.10. ANALOG CONTROL REGISTERS

20h - Trickle Charge

This register controls the Trickle Charger. The Configuration Key CONFKEY must be written with the value 9Dh in order to enable access to this register. See TRICKLE CHARGER.

| Address | Function | Bit 7 | Bit 6 | Bit 5 | Bit 4 | Bit 3 | Bit 2 | Bit 1 | Bit 0 |
|---------|----------------|----------------------------------|--|-------|-------|-------|-------|-------|-------|
| 20h | Trickle Charge | TCS | | | | DIODE | | ROUT | |
| | Reset | 0 | 0 | 0 | 0 | 0 | 0 | 0 | 0 |
| Bit | Symbol | Value | Description | | | | | | |
| 7:4 | TCS | 1010 | Trickle Charge Select. A value of 1010 enables the trickle charge function. All other values disable the Trickle Charger. | | | | | | |
| 3:2 | DIODE | Diode for the Trickle Charger | | | | | | | |
| | | 00 | Disables the Trickle Charger. | | | | | | |
| | | 01 | Inserts a schottky diode into the trickle charge circuit, with a voltage drop of 0.3V. | | | | | | |
| | | 10 | Inserts a standard diode into the trickle charge circuit, with a voltage drop of 0.6V. | | | | | | |
| 1:0 | ROUT | Resistor for the Trickle Charger | | | | | | | |
| | | 00 | Disables the Trickle Charger. | | | | | | |
| | | 01 | The series resistor of the trickle charge circuit is 3 kΩ | | | | | | |
| | | 10 | The series resistor of the trickle charge circuit is 6 kΩ | | | | | | |
| | | 11 | The series resistor of the trickle charge circuit is 11 kΩ | | | | | | |

21h - BREF Control

This register controls the reference voltages used for the Analog Comparator. CONFKEY must be written with the value 9Dh in order to enable access to this register.

| Address | Function | Bit 7 | Bit 6 | Bit 5 | Bit 4 | Bit 3 | Bit 2 | Bit 1 | Bit 0 |
|---------|--------------|--|--|-------|-------|---|-------|-------|-------|
| 21h | BREF Control | BREF | | | | RESERVED | | | |
| | Reset | 1 | 1 | 1 | 1 | 0 | 0 | 0 | 0 |
| Bit | Symbol | Value | Description | | | | | | |
| 7:4 | BREF | Voltage Reference This selects the voltage reference which is compared to the battery voltage V_{BACKUP} to produce the BREFD signal (see ANALOG CONTROL REGISTERS, 2Fh – Analog Status and BREF ELECTRICAL CHARACTERISTICS). The valid BREF values are 7h, Bh, Dh, and Fh. All other values are RESERVED. | | | | | | | |
| | | | V_{BACKUP} Falling Voltage (TYP), (BPOL = 0) | | | V_{BACKUP} Rising Voltage (TYP), (BPOL = 1) | | | |
| | | 0111 | 2.5V | | | 3.0V | | | |
| | | 1011 | 2.1V | | | 2.5V | | | |
| | | 1101 | 1.8V | | | 2.2V | | | |
| | | 1111 | 1.4V – Default value | | | 1.6V – Default value | | | |
| 3:0 | RESERVED | 0000 to 1111 | RESERVED | | | | | | |

26h – Cap_RC Control

This register holds the enable code for the Autocalibration Filter Capacitor connected to the Cap_RC pin. Writing the value A0h to this register enables the Cap_RC pin. Writing the value 00h to this register disables the Cap_RC pin. No other value may be written to this register. The Configuration Key CONFKEY must be written with the value 9Dh prior to writing the CAPRC Register.

| Address | Function | Bit 7 | Bit 6 | Bit 5 | Bit 4 | Bit 3 | Bit 2 | Bit 1 | Bit 0 |
|---------|----------------|-------|--------------------------|-------|-------|-------|-------|-------|-------|
| 26h | Cap_RC Control | CAPRC | | | | | | | |
| | Reset | 0 | 0 | 0 | 0 | 0 | 0 | 0 | 0 |
| Bit | Symbol | Value | Description | | | | | | |
| 7:0 | CAPRC | 00h | Disables the Cap_RC pin. | | | | | | |
| | | A0h | Enables the Cap_RC pin. | | | | | | |

27h – IO Batmode Register

This register holds the IOBM bit which controls the enabling and disabling of the I²C interface when a Brownout Detection occurs. It may only be written if the Configuration Key CONFKEY contains the value 9Dh. All undefined bits must be written with 0.

| Address | Function | Bit 7 | Bit 6 | Bit 5 | Bit 4 | Bit 3 | Bit 2 | Bit 1 | Bit 0 |
|---------|---------------------|---|---|-------|-------|-------|-------|-------|-------|
| 27h | IO Batmode Register | IOBM | RESERVED | | | | | | |
| | Reset | 1 | 0 | 0 | 0 | 0 | 0 | 0 | 0 |
| Bit | Symbol | Value | Description | | | | | | |
| 7 | IOBM | I ² C in VBACKUP Power state | | | | | | | |
| | | 0 | The I ² C interface is disabled in the VBACKUP Power state in order to prevent erroneous accesses to the RV-1805-C3 if the bus master loses power. | | | | | | |
| | | 1 | The RV-1805-C3 will not disable the I ² C interface even if V _{DD} goes away and V _{BACKUP} is still present. This allows external access while the RV-1805-C3 is powered by V _{BACKUP} . | | | | | | |
| 6:0 | RESERVED | 0000000 | RESERVED - must write only 00000000. | | | | | | |

2Fh – Analog Status Register (Read Only)

This register holds eight status bits which indicate the voltage levels of the V_{DD} and V_{BACKUP} power inputs.

| Address | Function | Bit 7 | Bit 6 | Bit 5 | Bit 4 | Bit 3 | Bit 2 | Bit 1 | Bit 0 |
|---------|------------------------------------|--------------|---|----------|-------|-------|-------|-------|----------|
| 2Fh | Analog Status Register (Read Only) | BREFD | BMIN | RESERVED | | | | VINIT | RESERVED |
| | Reset | | | | | | | | |
| Bit | Symbol | Value | Description | | | | | | |
| 7 | BREFD | 0 | The V _{BACKUP} input voltage is below the BREF threshold. | | | | | | |
| | | 1 | The V _{BACKUP} input voltage is above the BREF threshold. | | | | | | |
| 6 | BMIN | 0 | The V _{BACKUP} input voltage is below the minimum operating voltage (1.2 V). | | | | | | |
| | | 1 | The V _{BACKUP} input voltage is above the minimum operating voltage (1.2 V). | | | | | | |
| 5:2 | RESERVED | 0000 to 1111 | RESERVED | | | | | | |
| 1 | VINIT | 0 | The V _{DD} input voltage is below the minimum power up voltage (1.6 V). | | | | | | |
| | | 1 | The V _{DD} input voltage is above the minimum power up voltage (1.6 V). | | | | | | |
| 0 | RESERVED | 0 or 1 | RESERVED | | | | | | |

30h – Output Control Register

This register holds bits which control the behavior of the I²C pins under various power down conditions. The Configuration Key CONFKEY must be written with the value 9Dh in order to enable access to this register.

| Address | Function | Bit 7 | Bit 6 | Bit 5 | Bit 4 | Bit 3 | Bit 2 | Bit 1 | Bit 0 |
|---------|-------------------------|-------|--|-------|-------|-------|-------|-------|-------|
| 30h | Output Control Register | WDBM | X | WDDS | X | RSTSL | X | X | CLKSL |
| | Reset | 0 | 0 | 0 | 0 | 0 | 0 | 0 | 0 |
| | Set X to 1 | | | | 1 | | | | |
| Bit | Symbol | Value | Description | | | | | | |
| 7 | WDBM | 0 | The WDI input is disabled when the RV-1805-C3 is powered from V _{BACKUP} . | | | | | | |
| | | 1 | The WDI input is enabled when the RV-1805-C3 is powered from V _{BACKUP} . | | | | | | |
| 6 | X | 0 | Unused, but has to be 0 to avoid extraneous leakage. Disables an internal input when the RV-1805-C3 is powered from V _{BACKUP} . | | | | | | |
| 5 | WDDS | 0 | The WDI input is enabled when the RV-1805-C3 is in Sleep Mode. | | | | | | |
| | | 1 | The WDI input is disabled when the RV-1805-C3 is in Sleep Mode. If WDI is disabled, it will appear as a 1 to the internal logic. | | | | | | |
| 4 | X | 1 | Unused, but has to be set to 1 to avoid extraneous leakage. Disables an internal input when the RV-1805-C3 is in Sleep Mode. | | | | | | |
| 3 | RSTSL | 0 | The $\overline{\text{RST}}$ output pin is completely disconnected when the RV-1805-C3 is in Sleep Mode. | | | | | | |
| | | 1 | The $\overline{\text{RST}}$ output pin is enabled when the RV-1805-C3 is in Sleep Mode. | | | | | | |
| 2 | X | 0 | Unused, but has to be 0 to avoid extraneous leakage. If 0, an internal output is completely disconnected when the RV-1805-C3 is in Sleep Mode. | | | | | | |
| 1 | X | 0 | Unused, but has to be 0 to avoid extraneous leakage. If 0, an internal output is completely disconnected when the RV-1805-C3 is in Sleep Mode. | | | | | | |
| 0 | CLKSL | 0 | The CLK/ $\overline{\text{INT}}$ output pin is completely disconnected when the RV-1805-C3 is in Sleep Mode. | | | | | | |
| | | 1 | The CLK/ $\overline{\text{INT}}$ output pin is enabled when the RV-1805-C3 is in Sleep Mode. | | | | | | |

3.11.ID REGISTERS**28h – ID0 - Part Number Upper Register (Read Only)**

This register holds the upper eight bits of the part number in BCD format, which is always 18h for the RV-1805-C3.

| Address | Function | Bit 7 | Bit 6 | Bit 5 | Bit 4 | Bit 3 | Bit 2 | Bit 1 | Bit 0 |
|---------|--|-----------------------|-------|-------|-------|-----------------------|-------|-------|-------|
| 28h | ID0 - Part Number Upper Register (Read Only) | Part Number - Digit 3 | | | | Part Number - Digit 2 | | | |
| | Reset | 0 | 0 | 0 | 1 | 1 | 0 | 0 | 0 |

29h – ID1 - Part Number Lower Register (Read Only)

This register holds the lower eight bits of the part number in BCD format, which is always 05h for the RV-1805-C3.

| Address | Function | Bit 7 | Bit 6 | Bit 5 | Bit 4 | Bit 3 | Bit 2 | Bit 1 | Bit 0 |
|---------|--|-----------------------|-------|-------|-------|-----------------------|-------|-------|-------|
| 29h | ID1 - Part Number Lower Register (Read Only) | Part Number - Digit 1 | | | | Part Number - Digit 0 | | | |
| | Reset | 0 | 0 | 0 | 0 | 0 | 1 | 0 | 1 |

2Ah – ID2 - Part Revision (Read Only)

This register holds the Revision number of the part.

| Address | Function | Bit 7 | Bit 6 | Bit 5 | Bit 4 | Bit 3 | Bit 2 | Bit 1 | Bit 0 | |
|---------|---------------------------------|-------|--|-------|-------|-------|-------|-------|-------|--|
| 2Ah | ID2 - Part Revision (Read Only) | MAJOR | | | | | MINOR | | | |
| | Reset | 0 | 0 | 0 | 1 | 0 | 0 | 1 | 1 | |
| Bit | Symbol | Value | Description | | | | | | | |
| 7:3 | MAJOR | 00010 | This field holds the major revision of the RV-1805-C3. | | | | | | | |
| 2:0 | MINOR | 011 | This field holds the minor revision of the RV-1805-C3. | | | | | | | |

2Bh – ID3 – Lot Lower (Read Only)

This register holds the lower 8 bits of the manufacturing lot number.

| Address | Function | Bit 7 | Bit 6 | Bit 5 | Bit 4 | Bit 3 | Bit 2 | Bit 1 | Bit 0 |
|---------|-----------------------------|--------------------------|--|-------|-------|-------|-------|-------|-------|
| 2Bh | ID3 – Lot Lower (Read Only) | Lot[7:0] | | | | | | | |
| | Reset | Preconfigured Lot Number | | | | | | | |
| Bit | Symbol | Value | Description | | | | | | |
| 7:0 | Lot[7:0] | 00h to FFh | This field holds the lower 8 bits of the manufacturing lot number. | | | | | | |

2Ch – ID4 – Unique ID Upper (Read Only)

This register holds part of the manufacturing information of the part, including bit 9 of the manufacturing lot number and the upper 7 bits of the unique part identifier. The 15-bit ID field contains a unique value for each RV-1805-C3 part.

| Address | Function | Bit 7 | Bit 6 | Bit 5 | Bit 4 | Bit 3 | Bit 2 | Bit 1 | Bit 0 |
|---------|----------------------------|--------------------------|--|-------|-------|-------|-------|-------|-------|
| 2Ch | ID4 – ID Upper (Read Only) | Lot[9] | ID[14:8] | | | | | | |
| | Reset | Preconfigured Value | | | | | | | |
| Bit | Symbol | Value | Description | | | | | | |
| 7 | Lot[9] | 0 or 1 | This field holds bit 9 of the manufacturing lot number. | | | | | | |
| 6:0 | ID[14:8] | 0000000 to 1111111 | This field holds the upper 7 bits of the unique part ID. | | | | | | |

2Dh – ID5 – Unique ID Lower (Read Only)

This register holds the lower 8 bits of the unique part identifier. The 15-bit ID field contains a unique value for each RV-1805-C3 part.

| Address | Function | Bit 7 | Bit 6 | Bit 5 | Bit 4 | Bit 3 | Bit 2 | Bit 1 | Bit 0 |
|---------|--------------------------------|---------------------|--|-------|-------|-------|-------|-------|-------|
| 2Dh | ID5 – Unique Lower (Read Only) | ID[7:0] | | | | | | | |
| | Reset | Preconfigured Value | | | | | | | |
| Bit | Symbol | Value | Description | | | | | | |
| 7:0 | ID[7:0] | 00h to FFh | This field holds the lower 8 bits of the unique part ID. | | | | | | |

2Eh – ID6 – Wafer (Read Only)

| Address | Function | Bit 7 | Bit 6 | Bit 5 | Bit 4 | Bit 3 | Bit 2 | Bit 1 | Bit 0 |
|---------|-------------------------|----------------------|---|-------|-------|-------|-------|----------|-------|
| 2Eh | ID6 – Wafer (Read Only) | Lot[8] | Wafer | | | | | RESERVED | |
| | Reset | Preconfigured Value | | | | | | | |
| Bit | Symbol | Value | Description | | | | | | |
| 7 | Lot[8] | 0 or 1 | This field holds bit 8 of the manufacturing lot number. | | | | | | |
| 6:1 | Wafer | 00000 to 11111 | This field holds the manufacturing wafer number. | | | | | | |
| 1:0 | RESERVED | 00 to 11 | RESERVED | | | | | | |

3.12. RAM REGISTERS**3Fh - Extension RAM Address**

This register controls access to the Extension RAM, and includes some miscellaneous control bits.

| Address | Function | Bit 7 | Bit 6 | Bit 5 | Bit 4 | Bit 3 | Bit 2 | Bit 1 | Bit 0 |
|---------|-----------------------|--------------|--|-----------|-------|----------|-------|-------|-------|
| 3Fh | Extension RAM Address | X | BPOL | WDIS | X | RESERVED | XADA | XADS | |
| | Reset | 0 | 0 | Read Only | | 0 | 0 | 0 | 0 |
| Bit | Symbol | Value | Description | | | | | | |
| 7 | X | 0 | Unused, but must be set to 0 to avoid extraneous leakage. If 0, an internal output is completely disconnected when the RV-1805-C3 is powered from V_{BACKUP} . | | | | | | |
| 6 | BPOL | BLF Polarity | | | | | | | |
| | | 0 | The Battery Low flag BLF is set when the V_{BACKUP} voltage goes below the BREF threshold. | | | | | | |
| 5 | WDIS | 0 | (read only) – WDI status. Currently low level on the WDI pin. | | | | | | |
| | | 1 | (read only) – WDI status. Currently high level on the WDI pin. | | | | | | |
| 4 | X | 0 | (read only) – Unused | | | | | | |
| 3 | RESERVED | 0 or 1 | RESERVED | | | | | | |
| 2 | XADA | 0 or 1 | This bit supplies the upper bit for the Alternate RAM address space. | | | | | | |
| 1:0 | XADS | 00 to 11 | This field supplies the two upper bits for the Standard RAM address space. | | | | | | |

40h - 7Fh – Standard RAM

64 bytes of RAM space. The data in the RAM is held when using battery power. The upper 2 bits of the effective memory RAM address are taken from the XADS field, and the lower 6 bits are taken from the address offset, supporting a total RAM of 256 bytes. The initial values of the RAM locations are undefined.

| XADS Upper 2 bits | Standard RAM address | | | Effective RAM | RAM data |
|-----------------------|----------------------|--------------------------------------|--------------------------------|-------------------------------------|-----------|
| | | | Lower 6 bits | Upper 2 & Lower 6 | |
| 00 | 40h ⋮ 7Fh | 01000000 (64) ⋮ 01111111 (127) | 000000 (0) ⋮ 111111 (63) | 00000000 (0) | 64 bytes |
| 01 | | | | 00111111 (63) | |
| | | | | 01000000 (64) | |
| 10 | | | | 01111111 (127) | |
| 11 | 10111111 (191) | 11000000 (192) | 64 bytes | | |
| | 11111111 (255) | | | | |
| Total RAM data | | | | 00000000 (0) ⋮ 11111111 (255) | 256 bytes |

80h - FFh – Alternate RAM

128 bytes of RAM space. The data in the RAM is held when using battery power. The upper bit of the effective RAM address is taken from the XADA bit, and the lower 7 bits are taken from the address offset, supporting a total RAM of 256 bytes. The initial values of the RAM locations are undefined.

| XADA Upper bit | Alternate RAM address | | | Effective RAM | RAM data |
|-----------------------|-----------------------|---------------------------------------|-----------------------------------|-------------------------------------|-----------|
| | | | Lower 7 bits | Upper 1 & Lower 7 | |
| 0 | 80h ⋮ FFh | 10000000 (128) ⋮ 11111111 (255) | 0000000 (0) ⋮ 1111111 (127) | 00000000 (0) | 128 bytes |
| 1 | | | | 01111111 (127) | |
| | 1 | 10000000 (128) | 128 bytes | | |
| 11111111 (255) | | | | | |
| Total RAM data | | | | 00000000 (0) ⋮ 11111111 (255) | 256 bytes |

3.13. REGISTER RESET VALUES SUMMARY

| Address | Function | Bit 7 | Bit 6 | Bit 5 | Bit 4 | Bit 3 | Bit 2 | Bit 1 | Bit 0 |
|---------|--|------------------------------------|------------------------------------|------------------------------------|-------|-------|-------|-------|-------|
| 00h | Hundredths | 1 | 0 | 0 | 1 | 1 | 0 | 0 | 1 |
| 01h | Seconds | 0 | 0 | 0 | 0 | 0 | 0 | 0 | 0 |
| 02h | Minutes | 0 | 0 | 0 | 0 | 0 | 0 | 0 | 0 |
| 03h | Hours | 0 | 0 | 0 | 0 | 0 | 0 | 0 | 0 |
| 04h | Date | 0 | 0 | 0 | 0 | 0 | 0 | 0 | 1 |
| 05h | Months | 0 | 0 | 0 | 0 | 0 | 0 | 0 | 1 |
| 06h | Years | 0 | 0 | 0 | 0 | 0 | 0 | 0 | 0 |
| 07h | Weekdays | 0 | 0 | 0 | 0 | 0 | 0 | 0 | 0 |
| 08h | Hundredths Alarm | 0 | 0 | 0 | 0 | 0 | 0 | 0 | 0 |
| 09h | Seconds Alarm | 0 | 0 | 0 | 0 | 0 | 0 | 0 | 0 |
| 0Ah | Minutes Alarm | 0 | 0 | 0 | 0 | 0 | 0 | 0 | 0 |
| 0Bh | Hours Alarm | 0 | 0 | 0 | 0 | 0 | 0 | 0 | 0 |
| 0Ch | Date Alarm | 0 | 0 | 0 | 0 | 0 | 0 | 0 | 0 |
| 0Dh | Months Alarm | 0 | 0 | 0 | 0 | 0 | 0 | 0 | 0 |
| 0Eh | Weekdays Alarm | 0 | 0 | 0 | 0 | 0 | 0 | 0 | 0 |
| 0Fh | Status | 0 | 0 | 0 | 0 | 0 | 0 | 0 | 0 |
| 10h | Control1 | 0 | 0 | 0 | 1 | 0 | 0 | 1 | 1 |
| 11h | Control2 | 0 | 0 | 1 | 1 | 1 | 1 | 0 | 0 |
| 12h | Interrupt Mask | 1 | 1 | 1 | 0 | 0 | 0 | 0 | 0 |
| 13h | Square Wave SQW | 0 | 0 | 1 | 0 | 0 | 1 | 1 | 0 |
| 14h | Calibration XT | 0 | Preconfigured (Factory Calibrated) | | | | | | |
| 15h | Calibration RC Upper | Preconfigured | | Preconfigured (Factory Calibrated) | | | | | |
| 16h | Calibration RC Lower | Preconfigured (Factory Calibrated) | | | | | | | |
| 17h | Sleep Control | 0 | 0 | 0 | 0 | 0 | 0 | 0 | 0 |
| 18h | Countdown Timer Control | 0 | 0 | 1 | 0 | 0 | 0 | 1 | 1 |
| 19h | Countdown Timer | 0 | 0 | 0 | 0 | 0 | 0 | 0 | 0 |
| 1Ah | Timer Initial Value | 0 | 0 | 0 | 0 | 0 | 0 | 0 | 0 |
| 1Bh | Watchdog Timer | 0 | 0 | 0 | 0 | 0 | 0 | 0 | 0 |
| 1Ch | Oscillator Control | 0 | 0 | 0 | 0 | 0 | 0 | 0 | 0 |
| 1Dh | Oscillator Status Register | 0 | 0 | 1 | 0 | 0 | 0 | 1 | 0 |
| 1Fh | Configuration Key | 0 | 0 | 0 | 0 | 0 | 0 | 0 | 0 |
| 20h | Trickle Charge | 0 | 0 | 0 | 0 | 0 | 0 | 0 | 0 |
| 21h | BREF Control | 1 | 1 | 1 | 1 | 0 | 0 | 0 | 0 |
| 26h | Cap_RC Control | 0 | 0 | 0 | 0 | 0 | 0 | 0 | 0 |
| 27h | IO Batmode Register | 1 | 0 | 0 | 0 | 0 | 0 | 0 | 0 |
| 28h | ID0 - Part Number Upper Register (Read Only) | 0 | 0 | 0 | 1 | 1 | 0 | 0 | 0 |
| 29h | ID1 - Part Number Lower Register (Read Only) | 0 | 0 | 0 | 0 | 0 | 1 | 0 | 1 |
| 2Ah | ID2 - Part Revision (Read Only) | 0 | 0 | 0 | 1 | 0 | 0 | 1 | 1 |
| 2Bh | ID3 – Lot Lower (Read Only) | Preconfigured Lot Number | | | | | | | |
| 2Ch | ID4 – Unique ID Upper (Read Only) | Preconfigured Value | | | | | | | |
| 2Dh | ID5 – Unique ID Lower (Read Only) | Preconfigured Value | | | | | | | |
| 2Eh | ID6 – Wafer (Read Only) | Preconfigured Value | | | | | | | |
| 2Fh | Analog Status Register (Read Only) | | | | | | | | |
| 30h | Output Control Register | 0 | 0 | 0 | 0 | 0 | 0 | 0 | 0 |
| 3Fh | Extension RAM Address | 0 | 0 | Read Only | | 0 | 0 | 0 | 0 |

4. DETAILED FUNCTIONAL DESCRIPTION

The RV-1805-C3 serves as a companion part for host processors including microcontrollers, radios, and digital signal processors. It tracks time as in a typical RTC product and additionally provides unique power management functionality that makes it ideal for highly energy-constrained applications. To support such operation, the RV-1805-C3 includes 3 distinct feature groups: 1) baseline timekeeping features, 2) advanced timekeeping features, and 3) power management features. Functions from each feature group may be controlled via I/O offset mapped registers. These registers are accessed using the I²C serial interface. Each feature group is described briefly below and in greater detail in subsequent sections.

1. The baseline timekeeping feature group supports two modes: a) XT oscillator mode and b) XT Autocalibration mode.
 - a. In XT mode the 32.768 kHz crystal is active and the 16.384 kHz level is digitally offset compensated for a maximum frequency accuracy (factory calibrated) and has an ultra-low current draw of 60 nA. The baseline timekeeping feature group also includes a standard set of counters monitoring hundredths of a second up through centuries. A complement of countdown timers and alarms may additionally be set to initiate interrupts or resets on several of the outputs.
 - b. The XT Autocalibration mode has the same features as the XT mode but additionally calibrates the RC oscillator periodically to the compensated XT oscillator.
2. The advanced timekeeping feature group supports two additional oscillation modes: a) RC oscillator mode, and b) RC Autocalibration mode.
 - a. At only 17 nA, the temperature-compensated RC oscillator mode with factory calibrated frequency at the 64 Hz level provides an even lower current draw than the XT oscillator for applications with reduced frequency accuracy requirements. A proprietary calibration algorithm allows the RV-1805-C3 to digitally tune the RC oscillator frequency to ± 16 ppm to the digitally offset compensated XT oscillator frequency with the accuracy as low as ± 2 ppm at a given temperature.
 - b. In Autocalibration mode, the RC oscillator is used as the primary oscillation source and is periodically calibrated against the digitally tuned XT oscillator. Autocalibration may be done automatically every 8.5 minutes or 17 minutes and may also be initiated via software. This mode enables average current draw of only 22 nA with frequency accuracy similar to the XT oscillator. The advanced timekeeping feature group also includes a rich set of input and output configuration options that enables the monitoring of external interrupts (e.g., pushbutton signals), the generation of clock outputs, and watchdog timer functionality.
3. Power management features built into the RV-1805-C3 enable it to operate as a backup device in both line-powered and battery-powered systems. An integrated power control module automatically detects when main power (V_{DD}) falls below a threshold and switches to backup power (V_{BACKUP}). Up to 512 bytes of ultra-low leakage RAM enable the storage of key parameters when operating on backup power.

The RV-1805-C3 is the first RTC to incorporate a number of more advanced power management features. In particular, the RV-1805-C3 includes a finite Sleep Control State Machine (integrated with the power control) that can control a host processor as it transitions between sleep/reset states and active states. Digital outputs can be configured to control the reset signal or interrupt input of the host controller. The RV-1805-C3 additionally integrates a power switch with $\sim 1 \Omega$ impedance that can be used to cut off ground current on the host microcontroller and reduce sleep current to < 1 nA. The RV-1805-C3 parts can wake up a sleeping system using internally generated timing interrupts or externally generated interrupts generated by digital inputs (e.g., using a pushbutton) or an analog comparator. The aforementioned functionality enables users to seamlessly power down host processors, leaving only the energy-efficient RV-1805-C3 chip awake. The RV-1805-C3 also includes voltage detection on the backup power supply.

Each functional block is explained in detail in the remainder of this section. Functional descriptions refer to the registers shown in the two Tables in Section REGISTER OVERVIEW. A detailed description of all registers can be found in Section REGISTER ORGANIZATION.

4.2. I²C INTERFACE

The I²C interface is for bidirectional, two-line communication between different ICs or modules. The device is accessed at addresses D2h/D3h, and supports Fast Mode (up to 400 kHz). The I²C interface consists of two lines: one bi-directional data line (SDA) and one clock line (SCL). Both lines are connected to a positive supply via pull-up resistors. Data transfer is initiated only when the interface is not busy.

I²C termination resistors should be above 2.2 k Ω , and for systems with short I²C bus wires/traces and few connections these terminators can typically be as large as 22 k Ω (for 400 kHz operation) or 56 k Ω (for 100 kHz operation). Larger resistors will produce lower system current consumption.

4.2.1. BUS NOT BUSY

Both SDA and SCL remain high.

4.2.2. BIT TRANSFER

One data bit is transferred during each clock pulse. The data on the SDA line remains stable during the HIGH period of the clock pulse, as changes in the data line at this time are interpreted as control signals. Data changes should be executed during the LOW period of the clock pulse (see figure below).

Bit transfer:

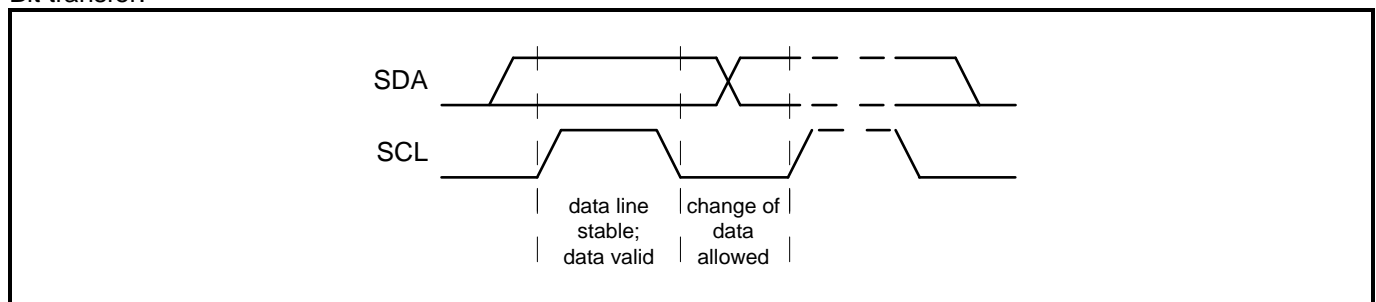

4.2.3. START AND STOP CONDITIONS

Both data and clock lines remain HIGH when the bus is not busy. A HIGH-to-LOW transition of the data line, while the clock is HIGH, is defined as the START condition (S). A LOW-to-HIGH transition of the data line, while the clock is HIGH, is defined as the STOP condition (P) (see figure below).

Definition of START and STOP conditions:

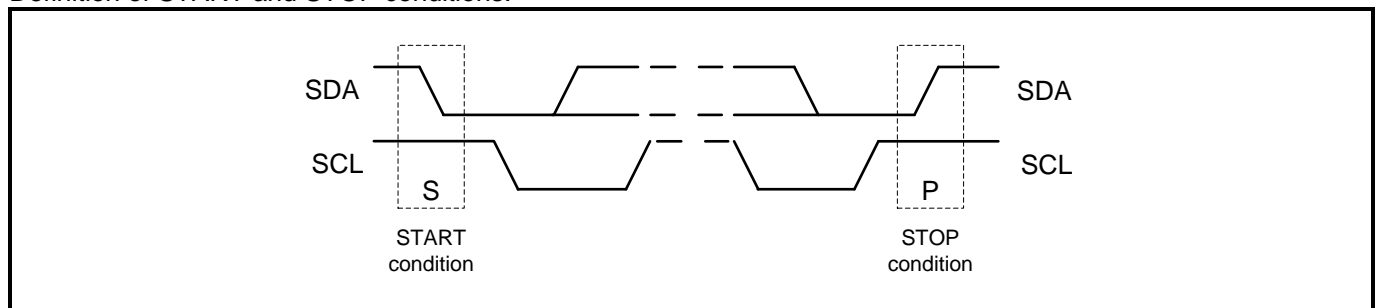

A START condition which occurs after a previous START but before a STOP is called a RESTART condition, and functions exactly like a normal STOP followed by a normal START.

4.2.4. DATA VALID

After a START condition, SDA is stable for the duration of the high period of SCL. The data on SDA may be changed during the low period of SCL. There is one clock pulse per bit of data. Each data transfer is initiated with a START condition and terminated with a STOP condition. The number of data bytes transferred between the START and STOP conditions is not limited. The information is transmitted byte-wide and each receiver acknowledges with a ninth bit.

4.2.5. SYSTEM CONFIGURATION

Since multiple devices can be connected with the I²C bus, all I²C bus devices have a fixed and unique device number built-in to allow individual addressing of each device.

The device that controls the I²C bus is the Master; the devices which are controlled by the Master are the Slaves. A device generating a message is a Transmitter; a device receiving a message is the Receiver. The RV-1805-C3 acts as a Slave-Receiver or Slave-Transmitter.

Before any data is transmitted on the I²C bus, the device which should respond is addressed first. The addressing is always carried out with the first byte transmitted after the start procedure. The clock signal SCL is only an input signal, but the data signal SDA is a bidirectional line.

System configuration:

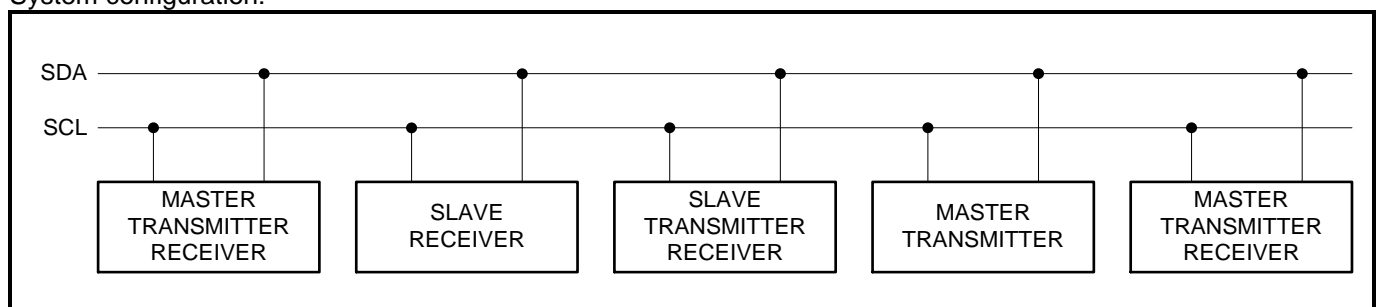

4.2.6. ACKNOWLEDGE

The number of data bytes transferred between the START and STOP conditions from transmitter to receiver is unlimited. Each byte of 8 bits is followed by an acknowledge cycle.

- A slave receiver, which is addressed, must generate an acknowledge cycle after the reception of each byte
- Also a master receiver must generate an acknowledge cycle after the reception of each byte that has been clocked out of the slave transmitter
- The device that acknowledges must pull-down the SDA line during the acknowledge clock pulse, so that the SDA line is stable LOW during the HIGH period of the related acknowledge clock pulse (set-up and hold times must be considered)
- A master receiver must signal an end of data to the transmitter by not generating an acknowledge cycle on the last byte that has been clocked out of the slave. In this event, the transmitter must leave the data line HIGH to enable the master to generate a STOP condition

Acknowledgement on the I²C bus is shown on the figure below.

Acknowledgement on the I²C bus:

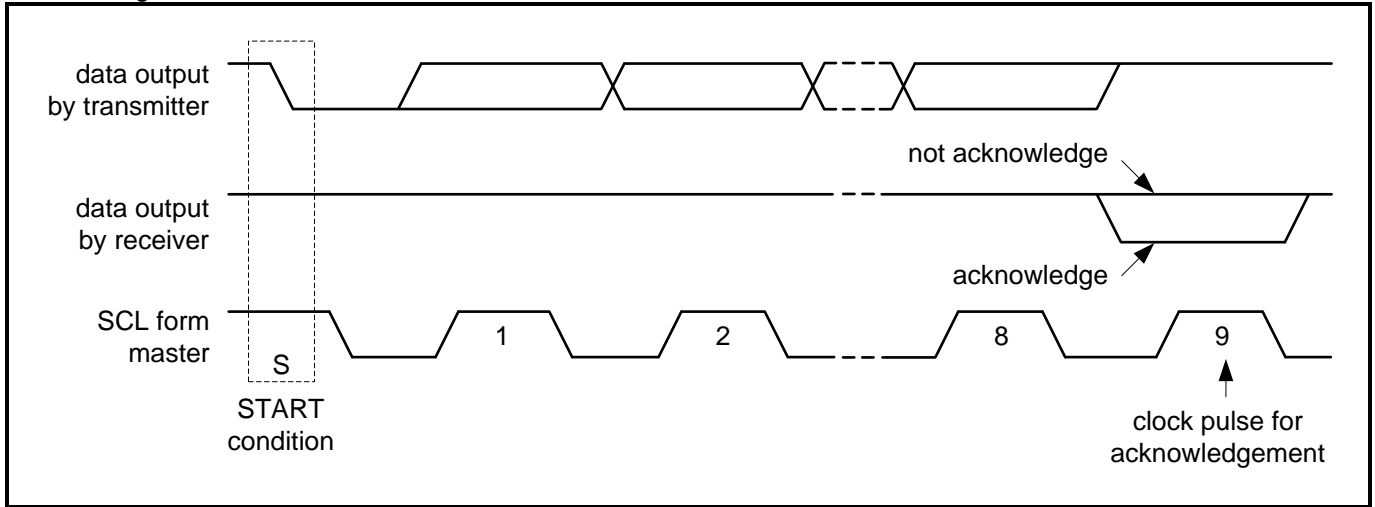

4.2.7.ADDRESSING

On the I²C bus the 7-bit slave address 1101001b is reserved for the RV-1805-C3. The entire I²C bus slave address byte is shown in the table below.

I²C slave address byte:

| Bit | Slave address | | | | | | | 0 |
|-----|---------------|---|---|---|---|---|---|-------------------|
| | 7 | 6 | 5 | 4 | 3 | 2 | 1 | |
| | MSB | | | | | | | LSB |
| | 1 | 1 | 0 | 1 | 0 | 0 | 1 | R/ \overline{W} |

After a START condition, the I²C slave address has to be sent to the RV-1805-C3 device. The R/ \overline{W} bit defines the direction of the following single or multiple byte data transfer. The 7-bit address is transmitted MSB first. If this address is 1101001b, the RV-1805-C3 is selected, the eighth bit indicate a write (R/ \overline{W} = 0) or a read (R/ \overline{W} = 1) operation (results in D2h or D3h) and the RV-1805-C3 supplies the ACK. The RV-1805-C3 ignores all other address values and does not respond with an ACK.

In the write operation, a data transfer is terminated by sending either the STOP condition or the START condition of the next data transfer.

4.2.8.WRITE OPERATION

Master transmits to Slave-Receiver at specified address. The Register Address is an 8-bit value that defines which register is to be accessed next. After reading or writing one byte, the Register Address is automatically incremented by 1.

- 1) Master sends out the START condition.
- 2) Master sends out Slave Address, D2h for the RV-1805-C3; the R/\bar{W} bit is a 0 indicating a write operation.
- 3) Acknowledgement from the RV-1805-C3.
- 4) Master sends out the Register Address to the RV-1805-C3.
- 5) Acknowledgement from the RV-1805-C3.
- 6) Master sends out the Data to write to the specified address in step 4).
- 7) Acknowledgement from the RV-1805-C3.
- 8) Steps 6) and 7) can be repeated if necessary. The address will be incremented automatically in the RV-1805-C3.
- 9) Master sends out the STOP Condition.

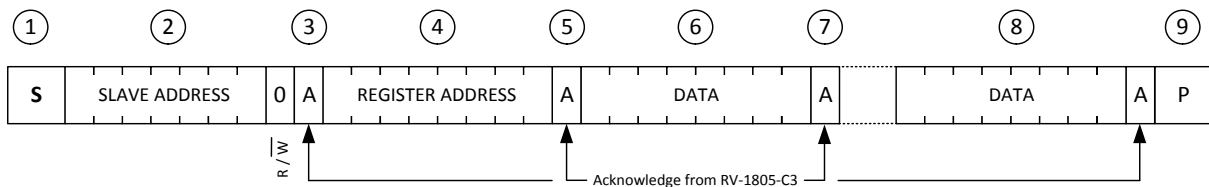

4.2.9.READ OPERATION AT SPECIFIC ADDRESS

Master reads data after setting Register Address:

- 1) Master sends out the START condition.
- 2) Master sends out Slave Address, D2h for the RV-1805-C3; the R/\bar{W} bit is a 0 indicating a write operation.
- 3) Acknowledgement from the RV-1805-C3.
- 4) Master sends out the Register Address to the RV-1805-C3.
- 5) Acknowledgement from the RV-1805-C3.
- 6) Master sends out the RESTART condition (STOP condition followed by START condition)
- 7) Master sends out Slave Address, D3h for the RV-1805-C3; the R/\bar{W} bit is a 1 indicating a read operation.
- 8) Acknowledgement from the RV-1805-C3.
- At this point, the Master becomes a Receiver, the Slave becomes the Transmitter.
- 9) The Slave sends out the Data from the Register Address specified in step 4).
- 10) Acknowledgement from the Master.
- 11) Steps 9) and 10) can be repeated if necessary.
- The address will be incremented automatically in the RV-1805-C3.
- 12) The Master, addressed as Receiver, can stop data transmission by not generating an acknowledge on the last byte that has been sent from the Slave-Transmitter. In this event, the Slave-Transmitter must leave the data line HIGH to enable the Master to generate a STOP condition.
- 13) Master sends out the STOP condition.

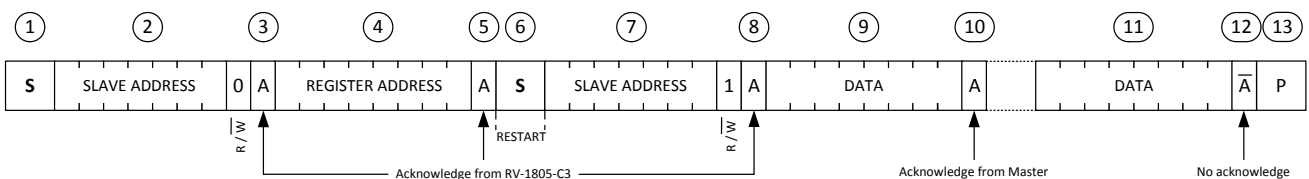

4.2.10. READ OPERATION

Master reads Slave-Transmitter immediately after first byte:

- 1) Master sends out the START condition.
- 2) Master sends out Slave Address, D3h for the RV-1805-C3; the R/ \overline{W} bit is a 1 indicating a read operation.
- 3) Acknowledgement from the RV-1805-C3.
At this point, the Master becomes a Receiver, the Slave becomes the Transmitter
- 4) The RV-1805-C3 sends out the Data from the last accessed Register Address incremented by 1.
- 5) Acknowledgement from the Master.
- 6) Steps 4) and 5) can be repeated if necessary.
The address will be incremented automatically in the RV-1805-C3.
- 7) The Master, addressed as Receiver, can stop data transmission by not generating an acknowledge on the last byte that has been sent from the Slave-Transmitter. In this event, the Slave-Transmitter must leave the data line HIGH to enable the Master to generate a STOP condition.
- 8) Master sends out the STOP condition.

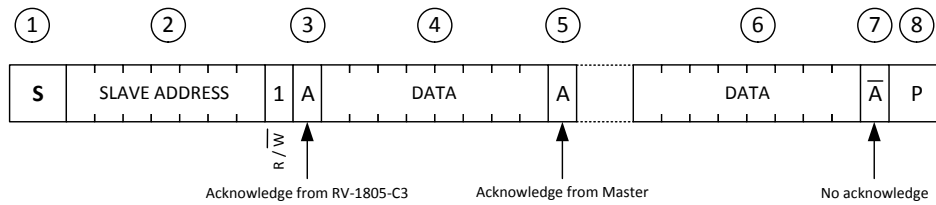

4.3. XT OSCILLATOR

The RV-1805-C3 includes a very power efficient crystal (XT) oscillator which runs at 32.768 kHz. This oscillator is selected by setting the OSEL bit to 0 and includes a low jitter calibration function.

4.4. RC OSCILLATOR

The RV-1805-C3 includes an extremely low power RC oscillator which runs at typically 122 Hz (Fnom = 128 Hz). This oscillator is selected by setting the OSEL bit to 1. Switching between the XT and RC Oscillators is guaranteed to produce less than one second of error in the Calendar Counters. The RV-1805-C3 may be configured to automatically switch to the RC Oscillator when V_{DD} drops below its threshold by setting the BOS bit, and/ or be configured to automatically switch if an XT Oscillator failure is detected by setting the FOS bit.

4.5. RTC COUNTER ACCESS

When reading any of the counters in the RTC using a burst operation, the 1 Hz and 100 Hz clocks are held off during the access. This guarantees that a single burst will either read or write a consistent timer value (other than the Hundredths Counter – see HUNDREDTHS SYNCHRONIZATION). There is a watchdog function to insure that a very long pause on the interface does not cause the RTC to lose a clock.

On a write to any of the Calendar Counters, the entire timing chain up to 100 Hz (if the XT Oscillator is selected) or up to 1Hz (if the RC Oscillator is selected) is reset to 0. This guarantees that the Counters will begin counting immediately after the write is complete, and that in the XT oscillator case the next 100 Hz clock will occur exactly 10 ms later. In the RC Oscillator case, the next 1 Hz clock will occur exactly 1 second later. This allows a burst write to configure all of the Counters and initiate a precise time start. Note that a Counter write may cause one cycle of a Square Wave SQW output to be of an incorrect period.

The WRTC bit must be set in order to write to any of the Counter registers. This bit can be cleared to prevent inadvertent software access to the Counters.

4.6. HUNDREDTHS SYNCHRONIZATION

If the Hundredths Counter is read as part of the counter burst, there is a small probability (approximately 1 in 109) that the Hundredths Counter rollover from 99 to 00 and the Seconds Counter increment will be separated by the read. In this case, correct read information can be guaranteed by the following algorithm.

1. Read the Counters, using a burst read. If the Hundredths Counter is neither 00 nor 99, the read is correct.
2. If the Hundredths Counter was 00, perform the read again. The resulting value from this second read is guaranteed to be correct.
3. If the Hundredths Counter was 99, perform the read again.
 - a. If the Hundredths Counter is still 99, the results of the first read are guaranteed to be correct. Note that it is possible that the second read is not correct.
 - b. If the Hundredths Counter has rolled over to 00, and the Seconds Counter value from the second read is equal to the Seconds Counter value from the first read plus 1, both reads produced correct values. Alternatively, perform the read again. The resulting value from this third read is guaranteed to be correct.
 - c. If the Hundredths Counter has rolled over to 00, and the Seconds Counter value from the second read is equal to the Seconds Counter value from the first read, perform the read again. The resulting value from this third read is guaranteed to be correct.

4.7. GENERATING HUNDREDTHS OF A SECOND

The generation of an exact 100 Hz signal for the Hundredths Counter requires a special logic circuit. The 2.048 kHz clock signal is divided by 21 for 12 iterations, and is alternately divided by 20 for 13 iterations. This produces an effective division of:

$$(21 * 12 + 20 * 13)/25 = 20.48$$

producing an exact long-term average 100 Hz output, with a maximum jitter of less than 1 ms. The Hundredths Counter is not available when the RC Oscillator is selected.

4.8. WATCHDOG TIMER

The RV-1805-C3 includes a Watchdog Timer, which can be configured to generate an interrupt or a reset if it times out. The Watchdog Timer is controlled by the Watchdog Timer Register (see TIMER REGISTERS, 1Bh - Watchdog Timer). The WDF field selects the frequency at which the timer is decremented, and the WDM field determines the multiplier value loaded into the timer when it is restarted. If the timer reaches a value of zero, the WDS bit determines whether an interrupt is generated at $\overline{\text{CLK/INT}}$ (if WDS is 0) or the $\overline{\text{RST}}$ output pin is asserted low (if WDS is 1). If interrupt selected and timer reaching zero, the WDF flag in the Status Register is set to 1, which may be cleared by setting the WDF flag to zero. If reset is selected, the $\overline{\text{RST}}$ output pin is asserted low within 1/16 second of the timer reaching zero and remains asserted low for 1/16 second, and the WDF flag is not set.

Two actions will restart the Watchdog Timer:

1. Writing the Watchdog Timer Register with a new watchdog value.
2. A change in the level of the WDI pin.

If the Watchdog Timer generates an interrupt or reset, the Watchdog Timer Register must be written in order to restart the Watchdog Timer function. If the WDM field is 0, the Watchdog Timer function is disabled.

The WDM multiplier field describes the maximum timeout delay. For example, if $\text{WD} = 01$ so that the clock period is 250 ms, a WDM value of 9 implies that the timeout will occur between 2000 ms and 2250 ms after writing the Watchdog Timer Register.

4.9. DIGITAL CALIBRATION

4.9.1. XT OSCILLATOR DIGITAL CALIBRATION

In order to improve the accuracy of the XT oscillator, a Distributed Digital Calibration function is included (see CALIBRATION REGISTERS, 14h - Calibration XT). This function uses a calibration value, OFFSETX, to adjust the clock period over a 16 second or 32 second calibration period. When the 32.768 kHz XT oscillator is selected, the clock at the 16.384 kHz level of the divider chain is modified on a selectable interval. Clock pulses are either added or subtracted to ensure accuracy of the counters. If the CMDX bit is a 0 (normal calibration), OFFSETX cycles of the 16.384 kHz clock level are gated (negative calibration) or replaced by 32.768 kHz level pulses (positive calibration) within every 32 second calibration period. In this mode, each step in OFFSETX modifies the clock frequency by 1.907 ppm, with a maximum adjustment of $\sim +120/-122$ ppm. If the CMDX bit is 1 (coarse calibration), OFFSETX cycles of the 16.384 kHz clock level are gated or replaced by the 32.768 kHz level pulses within every 16 second calibration period. In this mode, each step in OFFSETX modifies the clock frequency by 3.815 ppm, with a maximum adjustment of $\sim +240/-244$ ppm. OFFSETX contains a two's complement value, so the possible steps are from -64 to +63 (7 bits). Note that unlike other implementations, the Distributed Digital Calibration guarantees that the clock is precisely calibrated every 32 seconds with normal calibration and every 16 seconds when coarse calibration is selected.

The pulses which are added to or subtracted from the 16.384 kHz clock level are spread evenly over each 16 or 32 second period using the Distributed Calibration algorithm. This insures that in XT mode the maximum cycle-to-cycle jitter in any clock of a frequency 16.384 kHz or lower caused by calibration will be no more than one 16.384 kHz period. This maximum jitter applies to all clocks in the RV-1805-C3, including the Calendar Counter, Countdown Timer and Watchdog Timer clocks and the clock driven onto the $\overline{\text{CLK/INT}}$ pin.

In addition to the normal calibration, the RV-1805-C3 also includes an Extended Calibration field to compensate a higher XT oscillator frequency. The frequency generated by the Crystal Oscillator may be reduced by -122 ppm multiplied by the value in the XTCAL (see OSCILLATOR REGISTERS, 1Dh – Oscillator Status Register) field (0, -122, -244 or -366 ppm). The clock is still precisely calibrated in 16 or 32 seconds. Normally, this field remains 0.

- At POR, the CMDX and OFFSETX values in register 14h are initialized with factory calibrated; non-volatile frequency offset compensation values (± 2 ppm at 25°C).
- Customer can adjust these values by overwriting the register 14h with new calculated values. See process below.

The XT oscillator calibration values CMDX, OFFSETX and XTCAL are determined by the following process:

1. Set the CMDX, OFFSETX and XTCAL register fields to 0 to ensure calibration is not occurring.
2. Select the XT oscillator by setting the OSEL bit to 0.
3. Configure a square wave SQW output on the output pin $\overline{\text{CLK/INT}}$ of frequency $F_{\text{nom}} = 32'768$ Hz.
4. Measure the frequency F_{meas} at the output pin in Hz.
5. Compute the adjustment value required in ppm: $P_{\text{Adj}} = ((32'768 - F_{\text{meas}}) * 1'000'000) / 32'768$
6. Compute the adjustment value in steps: $\text{Adj} = P_{\text{Adj}} / (1'000'000 / 2^{19}) = P_{\text{Adj}} / (1.90735)$
7. If $\text{Adj} < -320$, the XT frequency is too high to be calibrated
8. Else if $\text{Adj} < -256$, set $\text{XTCAL} = 3$, $\text{CMDX} = 1$, $\text{OFFSETX} = (\text{Adj} + 192) / 2$
9. Else if $\text{Adj} < -192$, set $\text{XTCAL} = 3$, $\text{CMDX} = 0$, $\text{OFFSETX} = \text{Adj} + 192$
10. Else if $\text{Adj} < -128$, set $\text{XTCAL} = 2$, $\text{CMDX} = 0$, $\text{OFFSETX} = \text{Adj} + 128$
11. Else if $\text{Adj} < -64$, set $\text{XTCAL} = 1$, $\text{CMDX} = 0$, $\text{OFFSETX} = \text{Adj} + 64$
12. Else if $\text{Adj} < 64$, set $\text{XTCAL} = 0$, $\text{CMDX} = 0$, $\text{OFFSETX} = \text{Adj}$
13. Else if $\text{Adj} < 128$, set $\text{XTCAL} = 0$, $\text{CMDX} = 1$, $\text{OFFSETX} = \text{Adj} / 2$
14. Else the XT frequency is too low to be calibrated

4.9.2.RC OSCILLATOR DIGITAL CALIBRATION

The RC Oscillator has a Distributed Digital Calibration function similar to that of the XT Oscillator (see CALIBRATION REGISTERS, 15h - Calibration RC Upper and 16h - Calibration RC Lower). However, because the RC Oscillator has a greater fundamental variability, the range of calibration is much larger, with four calibration ranges selected by the CMDR field. When the RC oscillator is selected, the clock at the 64 Hz level of the divider chain is modified on a selectable interval using the calibration value OFFSETR. Clock pulses are either added or subtracted to ensure accuracy of the counters. If the CMDR field is 00, OFFSETR cycles of the 64 Hz clock level are gated (negative calibration) or replaced by 128 Hz level pulses (positive calibration) within every 8'192 second calibration period. In this mode, each step in OFFSETR modifies the clock frequency by 1.907 ppm, with a maximum adjustment of +15'623/-15'625 ppm (+/- 1.56%). If the CMDR field is 01, OFFSETR cycles of the 64 Hz clock level are gated or replaced by the 128 Hz level pulses within every 4'096 second calibration period. In this mode, each step in OFFSETR modifies the clock frequency by 3.815 ppm, with a maximum adjustment of +31'246/-31'250 ppm (+/-3.12%). If the CMDR field is 10, OFFSETR cycles of the 64 Hz clock level are gated (negative calibration) or replaced by 128 Hz level pulses (positive calibration) within every 2'048 second calibration period. In this mode, each step in OFFSETR modifies the clock frequency by 7.63 ppm, with a maximum adjustment of +62'487/-62'500 ppm (+/- 6.25%). If the CMDR field is 11, OFFSETR cycles of the 64 Hz clock level are gated or replaced by pulses from the 128 Hz clock level within every 1'024 second calibration period. In this mode, each step in OFFSETR modifies the clock frequency by 15.26 ppm, with a maximum adjustment of +124'985/-125'000 ppm (+/-12.5%). OFFSETR contains a two's complement value, so the possible steps are from -8'192 to +8'191 (14 bits).

The pulses which are added to or subtracted from the 64 Hz clock level are spread evenly over each 8'192, 4'096, 2'048 or 1'024 second period using the Distributed Calibration algorithm. This insures that in RC mode the maximum cycle-to-cycle jitter in any clock of a frequency 64 Hz or lower caused by calibration will be no more than one 64 Hz period. This maximum jitter applies to all clocks in the RV-1805-C3, including the Calendar Counter, Countdown Timer and Watchdog Timer clocks and the clock driven onto the CLK/ $\overline{\text{INT}}$ pins.

- At POR, the CMDR and OFFSETR (OFFSETRU and OFFSETRL) values in register 15h and 16h are initialized with factory calibrated, non-volatile frequency offset compensation values (± 16 ppm at 25°C, $V_{DD} = 2.8$ V).
- Customer can adjust these values by overwriting the registers 15h and 16h with new calculated values. See process below.
- The RC oscillator digital calibration is also used by the XT Autocalibration and RC Autocalibration function (see XT AUTOCALIBRATION MODE and RC AUTOCALIBRATION MODE).

The RC oscillator calibration values CMDR and OFFSETR are determined by the following process:

1. Set the CMDR and OFFSETR register fields to 0 to insure calibration is not occurring.
2. Select the RC oscillator by setting the OSEL bit to 1.
3. Configure a square wave SQW output on the output pin CLK/ $\overline{\text{INT}}$ of frequency $F_{nom} = 128$ Hz.
4. Measure the frequency F_{meas} at the output pin.
5. Compute the adjustment value required in ppm as $((128 - F_{meas}) * 1'000'000) / F_{meas} = PAdj$
6. Compute the adjustment value in steps as $PAdj / (1'000'000 / 2^{19}) = PAdj / (1.90735) = Adj$
7. If $Adj < -65'536$, the RC frequency is too high to be calibrated
8. Else if $Adj < -32'768$, set CMDR = 3, OFFSETR = $Adj / 8$
9. Else if $Adj < -16'384$, set CMDR = 2, OFFSETR = $Adj / 4$
10. Else if $Adj < -8'192$, set CMDR = 1, OFFSETR = $Adj / 2$
11. Else if $Adj < 8'192$, set CMDR = 0, OFFSETR = Adj
12. Else if $Adj < 16'384$, set CMDR = 1, OFFSETR = $Adj / 2$
13. Else if $Adj < 32'768$, set CMDR = 2, OFFSETR = $Adj / 4$
14. Else if $Adj < 65'536$, set CMDR = 3, OFFSETR = $Adj / 8$
15. Else the RC frequency is too low to be calibrated

The following figure shows the modified clock at the 64 Hz level with the achieved average time accuracy in ppm at 96 seconds (arbitrary). The average calculation was started at the time $t_0 = 0$ seconds ($T_A = 25^\circ\text{C}$ and $V_{DD} = 3.0\text{ V}$).

Example with the modified RC oscillator clock at the 64 Hz level:

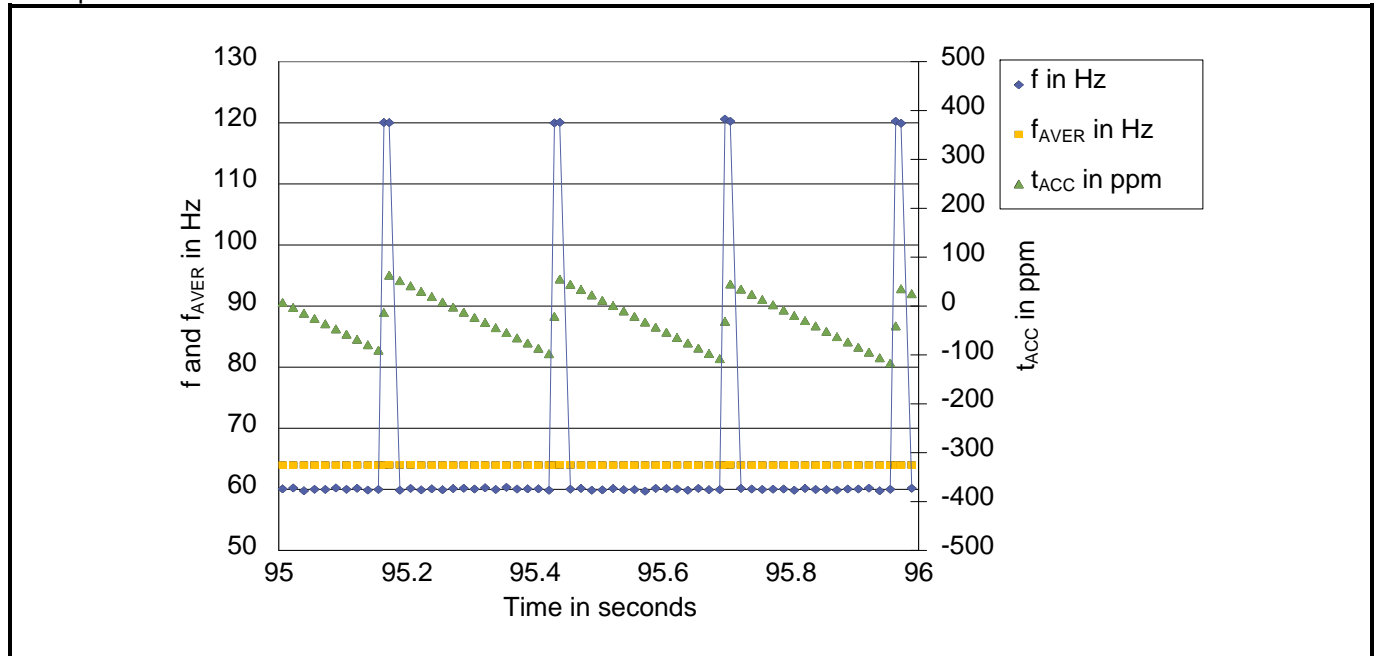

| SYMBOL | DESCRIPTION | UNIT |
|-------------------|--|------|
| f | Frequency of every measured period. The RC oscillator frequency in this example is about 120 Hz and therefore the divided frequency about 60 Hz. | Hz |
| f _{AVER} | The average frequency from t_0 to the current time (64 Hz level: after 96 seconds: -120 ppm to +20 ppm). | Hz |
| t _{ACC} | The average time accuracy from t_0 to the current time (after 96 seconds: -120 ppm to +20 ppm). | ppm |

4.10. AUTOCALIBRATION

The RV-1805-C3 includes the capability of using the internal RC Oscillator for all timing functions. For increased accuracy at a small power penalty, the RC Oscillator may be periodically calibrated to the digitally calibrated Crystal (XT) Oscillator which is turned on only during this calibration. The overall process is referred to as Autocalibration and under most conditions produces a clock with long term accuracy essentially indistinguishable from the digitally calibrated XT Oscillator alone, as shown in the RC/Acal bubble in the following Figure.

Basic Mode Comparison:

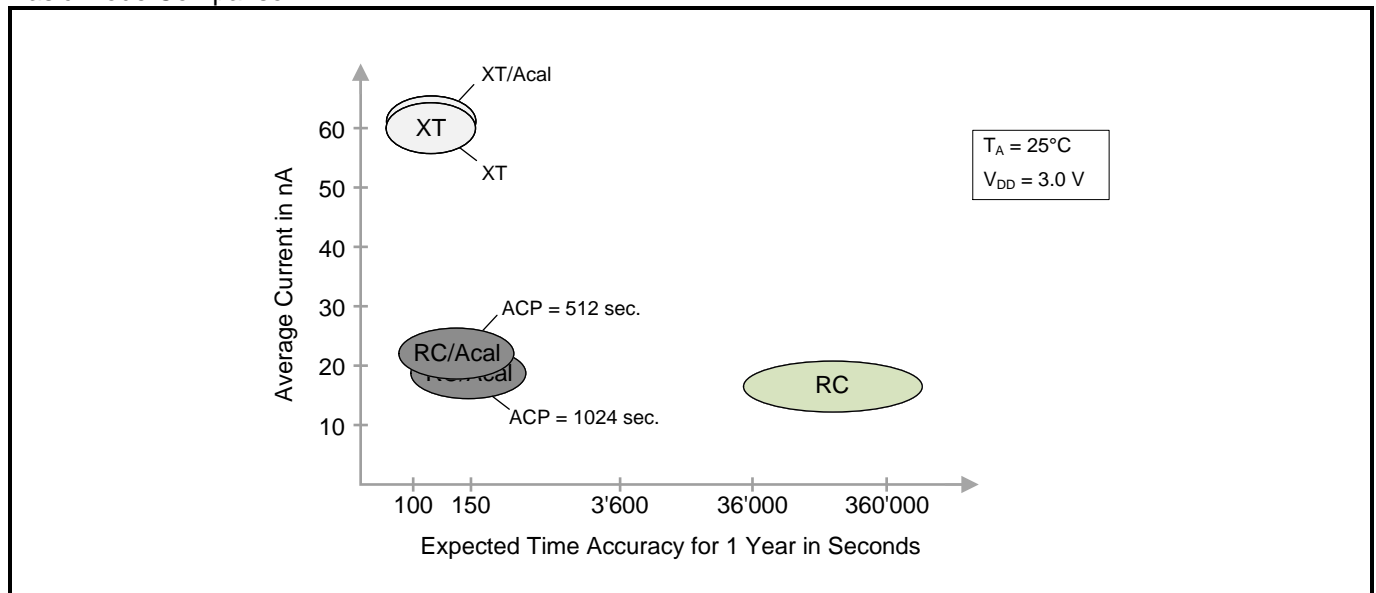

4.11. BASIC AUTOCALIBRATION OPERATION

The RV-1805-C3 includes a very powerful automatic calibration feature, referred to as Autocalibration, which allows the RC Oscillator to be automatically calibrated to the digitally calibrated XT Oscillator. The digitally calibrated XT Oscillator typically has much better stability than the RC Oscillator, but the RC Oscillator requires significantly less power. Autocalibration enables many system configurations to achieve accuracy and stability similar to that of the digitally calibrated XT Oscillator while drawing current similar to that of the RC Oscillator. Autocalibration functions in two primary modes: XT Autocalibration Mode and RC Autocalibration Mode.

4.11.1. AUTOCALIBRATION OPERATION

The Autocalibration operation counts the number of calibrated XT clock cycles within a specific period as defined by the RC Oscillator and then loads new values into the Calibration RC Upper and RC Lower registers which will then adjust the RC Oscillator output to match the digitally calibrated XT frequency. In most cases Autocalibration is configured by the host controller over the serial interface when the RV-1805-C3 is initialized.

4.11.2. XT AUTOCALIBRATION MODE

XT Autocalibration Mode is used when the digitally calibrated XT Oscillator is normally active, but the system is configured to switch to the RC Oscillator on a failure or a switchover to battery power (see also AUTOMATIC SWITCHOVER SUMMARY). In XT Autocalibration Mode, the OSEL register bit is set to 0, ACAL is set to 10 or 11 and the RV-1805-C3 uses the XT Oscillator whenever the system power V_{DD} is above the V_{DDSWF} voltage. The RC Oscillator is periodically automatically calibrated to the XT Oscillator. If the BOS bit is set, when V_{DD} drops below the V_{DDSWF} threshold the system will switch to using V_{BACKUP} , the clocks will begin using the RC Oscillator (Autocalibration Mode according to the ACAL field) and the XT Oscillator will be disabled to reduce power requirements. Because the RC Oscillator has been continuously calibrated to the digitally calibrated XT Oscillator, it will be already very accurate when the switch occurs. When V_{DD} is again above the threshold, the system will switch back to use the XT Oscillator in the XT Autocalibration Mode. It is possible to gain or lose up to one second during a switchover between the oscillators.

4.11.3. RC AUTOCALIBRATION MODE

RC Autocalibration Mode is used when the RC Oscillator is always used as the clock but it is desired to maintain the frequency of the RC Oscillator as close to the digitally calibrated XT Oscillator as possible. In RC Autocalibration Mode, the OSEL register bit is set to 1, ACAL is set to 10 or 11 and the RV-1805-C3 uses the RC Oscillator at all times. However, periodically the XT Oscillator is turned on and the RC Oscillator is calibrated to the XT Oscillator. This allows the system to operate most of the time with the XT Oscillator off but allow continuous calibration of the RC Oscillator and maintain high accuracy for the RC Oscillator.

4.11.4. AUTOCALIBRATION FREQUENCY AND CONTROL

The Autocalibration function is controlled by the ACAL field in the Oscillator Control register as shown in the following Table. If ACAL is 00, no Autocalibration occurs. If ACAL is 10 or 11, Autocalibration occurs every 1024 or 512 seconds, which is referred to as the Autocalibration Period (ACP). In RC Autocalibration Mode, an Autocalibration operation results in the digitally calibrated XT Oscillator being enabled for roughly 50 seconds. The 512 second Autocalibration cycles have the XT Oscillator enabled approximately 10% of the time, while 1024 second Autocalibration cycles have the XT Oscillator enabled approximately 5% of the time.

| ACAL Value | Autocalibration Mode |
|------------|--|
| 00 | No Autocalibration |
| 01 | RESERVED |
| 10 | Autocalibrate every 1024 seconds (~17minutes) |
| 11 | Autocalibrate every 512 seconds (~8.5 minutes) |

If ACAL is 00 and is then written with a different value, an Autocalibration cycle is immediately executed. This allows Autocalibration to be completely controlled by software. As an example, software could choose to execute an Autocalibration cycle every 2 hours by keeping ACAL at 00, getting a two hour interrupt using the alarm function, generating an Autocalibration cycle by writing ACAL to 10 or 11, and then returning ACAL to 00.

4.11.5. Cap_RC PIN

In order to produce the optimal accuracy for the Autocalibrated RC Oscillator, a 47 pF capacitor must be connected between the Cap_RC pin and V_{SS}. In order to enable the filter, the value A0h must be written to CAPRC at address 26h (Section ANALOG CONTROL REGISTERS). The Cap_RC filter is disabled by writing 00h to CAPRC. No other values should be written to this register. The Configuration Key CONFKEY must be written with the value 9Dh immediately prior to writing to the Cap_RC Control Register CAPRC. If the filter capacitor is not connected to the Cap_RC pin or is not enabled, the Autocalibrated RC Oscillator frequency will typically be between 10 and 50 ppm lower than the digitally calibrated XT Oscillator. If the capacitor is connected to the Cap_RC pin and enabled, the RC Oscillator frequency will be within the accuracy range specified in the OSCILLATOR PARAMETERS table of the XT Oscillator.

4.11.6. AUTOCALIBRATION FAILURE

If the operating temperature of the RV-1805-C3 exceeds the Autocalibration range specified in the Oscillator Parameters table or internal adjustment parameters are altered incorrectly, it is possible that the basic frequency of the RC Oscillator is so far away from the nominal 128 Hz value (off by more than 12%) that the RC Calibration circuitry does not have enough range to correctly calibrate the RC Oscillator. If this situation is detected during an Autocalibration operation, the ACF interrupt flag is set, an interrupt is generated if the ACIE register bit is set and the Calibration RC registers (15h and 16h) are not updated.

If an Autocalibration failure is detected while running in RC Autocalibration mode, it is advisable to switch into XT Autocalibration mode to maintain the timing accuracy. This is done by first ensuring a XT oscillator failure has not occurred (OF flag = 0) and then clearing the OSEL bit. The ACAL field should remain set to either 11 (512 second period) or 10 (1024 second period). After the switch occurs, the OMODE bit is cleared.

While continuing to operate in XT Autocalibration mode, the following steps can be used to determine when it is safe to return to RC Autocalibration mode.

1. Clear the ACF flag and ACIE register bit.
2. Setup the Countdown Timer or Alarm to interrupt after the next Autocalibration cycle completes or longer time period.
3. After the interrupt occurs, check the status of the ACF flag.
4. If the ACF flag is set, it is not safe to return to RC Autocalibration mode. Clear the ACF flag and repeat steps 2-4.
5. If the ACF flag is still cleared, it is safe to return to RC Autocalibration mode by setting the OSEL bit.

As mentioned in the RC oscillator section, switching between XT and RC oscillators is guaranteed to produce less than one second of error. However, this error needs to be considered and can be safely managed when implementing the steps above. For example, switching between oscillator modes every 48 hours will produce less than 6 ppm of deviation.

4.11.7. FREQUENCY ACCURACY IN RC AUTOCALIBRATION MODE

RC Autocalibration Mode is typically the most useful mode, because it allows a dramatic reduction in the power used by the RV-1805-C3 while maintaining the accuracy of the internal clock. The RC is always used as the internal clock so that no time deviations occur as can be seen with XT Autocalibration Mode and automatic switchover. RC Autocalibration Mode is the only applicable mode in systems where there is only a single battery supply, which is very common. Because the RC Oscillator is fundamentally less stable with temperature (typically +/- 1%, or 10'000 ppm, over the full temperature range) than the digitally calibrated XT Oscillator (typically within 150 ppm over the full temperature range), many applications cannot use the RC Oscillator alone as the timing clock. RC Autocalibration improves the accuracy of the RC Oscillator by continuously adjusting it to match the calibrated XT Oscillator.

Autocalibration maintains the RC Oscillator at a frequency very close to the digitally calibrated XT Oscillator, but there are obviously small deviations which can occur on each cycle. However, as temperature and the raw RC Oscillator frequency vary, deviations typically cancel each other out and produce very low accumulated deviation. The following Figure shows a time sequence with varying frequency. The heavy shaded line shows the variation of the raw RC Oscillator on the 64 Hz level, and the vertical dashed lines indicate the boundaries of Autocalibration Periods (ACPs, either 512 or 1024 seconds). The RC Oscillator is calibrated within a small number of PPM at the beginning of each ACP to the digitally calibrated XT Oscillator, so the calibrated RC frequency is the saw tooth function in the center of the figure, with the accumulated deviation in each ACP shown by the shaded triangles.

Autocalibration Deviation Cancellation:

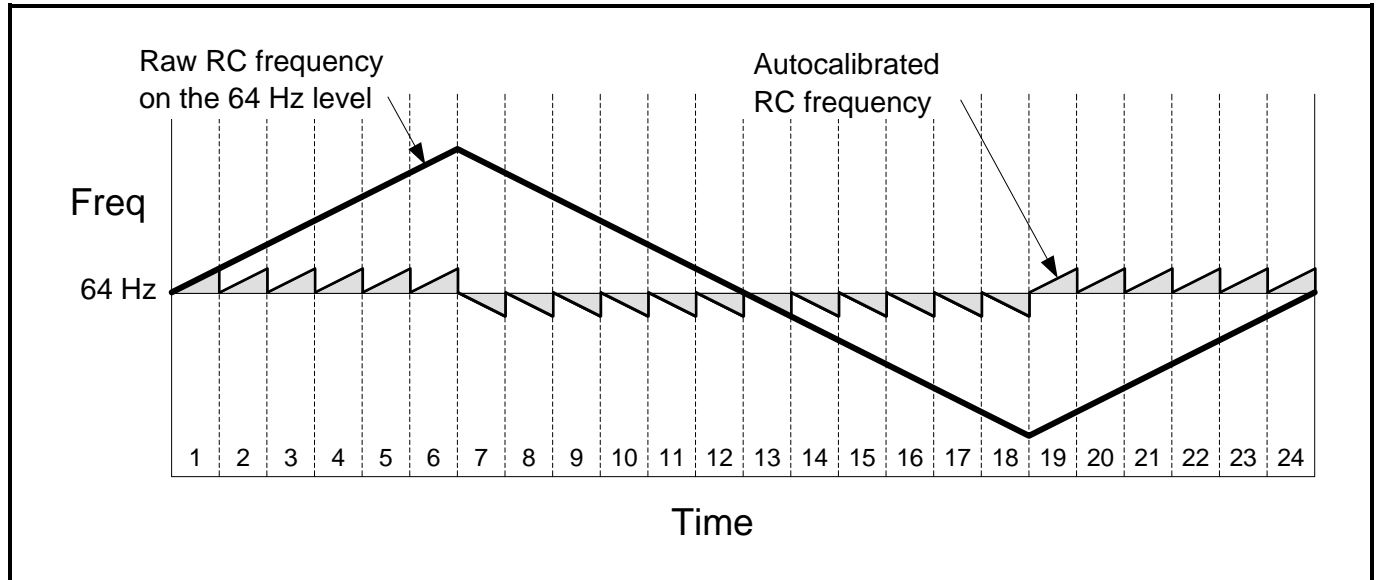

Although some deviation is accumulated in each ACP, it can be seen that the positive deviations which occur when the frequency is rising are cancelled by the negative deviations when the frequency is falling. Over any significant period of time, the net accumulated deviation is almost completely determined by the frequency difference between the beginning and end of the period and the rate of change of the frequency with time.

Since the frequencies of both the RC and the XT Oscillators are functions of temperature, and temperature changes are easy to understand and quantify, accumulated deviation is measured as a function of the temperature profile. The behavior of RC Autocalibration has been modeled by varying the temperature in a random way and simulating the desired period, which in the cases below is one year. The temperature rises or falls at a random rate between twice the average rate specified and the negative of that value, and is limited to the specified maximum and minimum temperatures. One thousand simulations were executed, and the specified deviation is the worst case result of all iterations.

The following Figure shows the maximum accumulated time deviation relative to the digitally calibrated XT Oscillator as a function of the maximum temperature range and the average temperature change rate over a one year period, in seconds (31 seconds in a year = 1 ppm), with an Autocalibration Period of 512 seconds. Note that even the lowest average change rate of 0.025 equates to one degree C every 40 minutes, which is still quite fast when averaged over an entire year. At this change rate, the deviation over the full temperature range is less than 95 seconds (<3 ppm).

Autocalibration Time Deviation relative to the digitally calibrated XT Oscillator, ACP = 512 seconds:

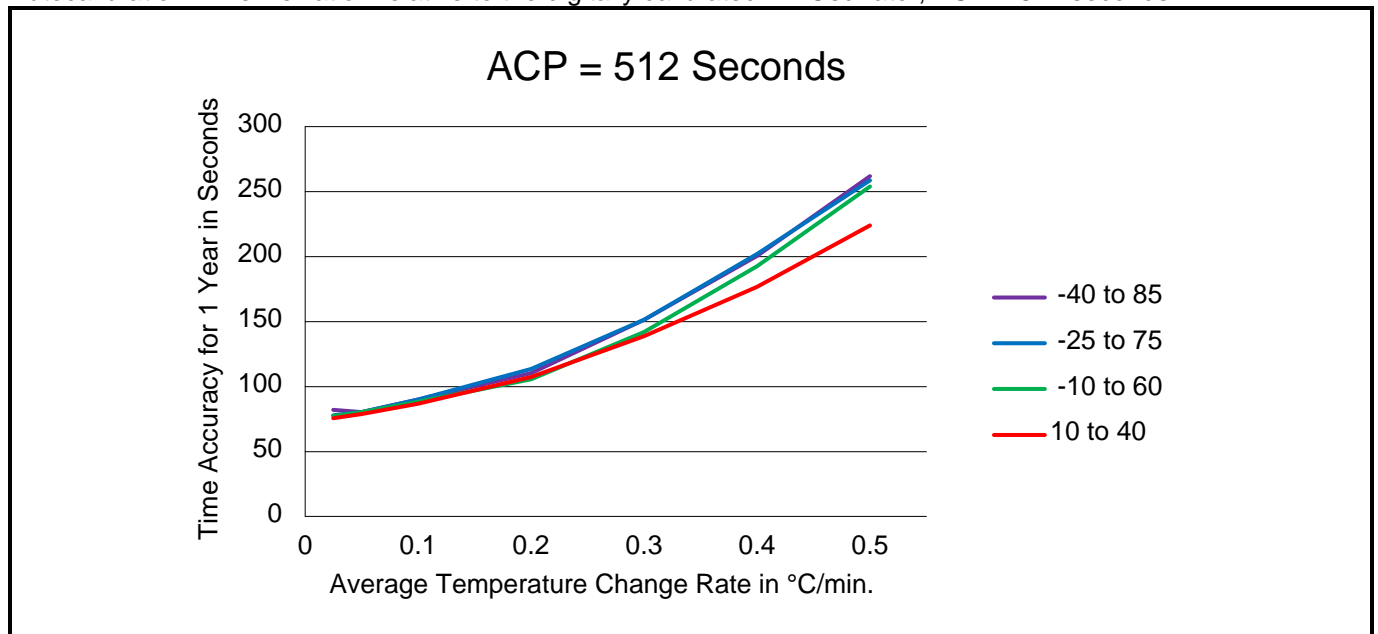

The following Figure shows the results when the ACP is 1024 seconds. At high temperature change rates, this setting produces roughly 3 times the deviation of the 512 second case, but the deviations for low change rates are still negligible.

Autocalibration Time Deviation relative to the digitally calibrated XT Oscillator, ACP = 1024 seconds:

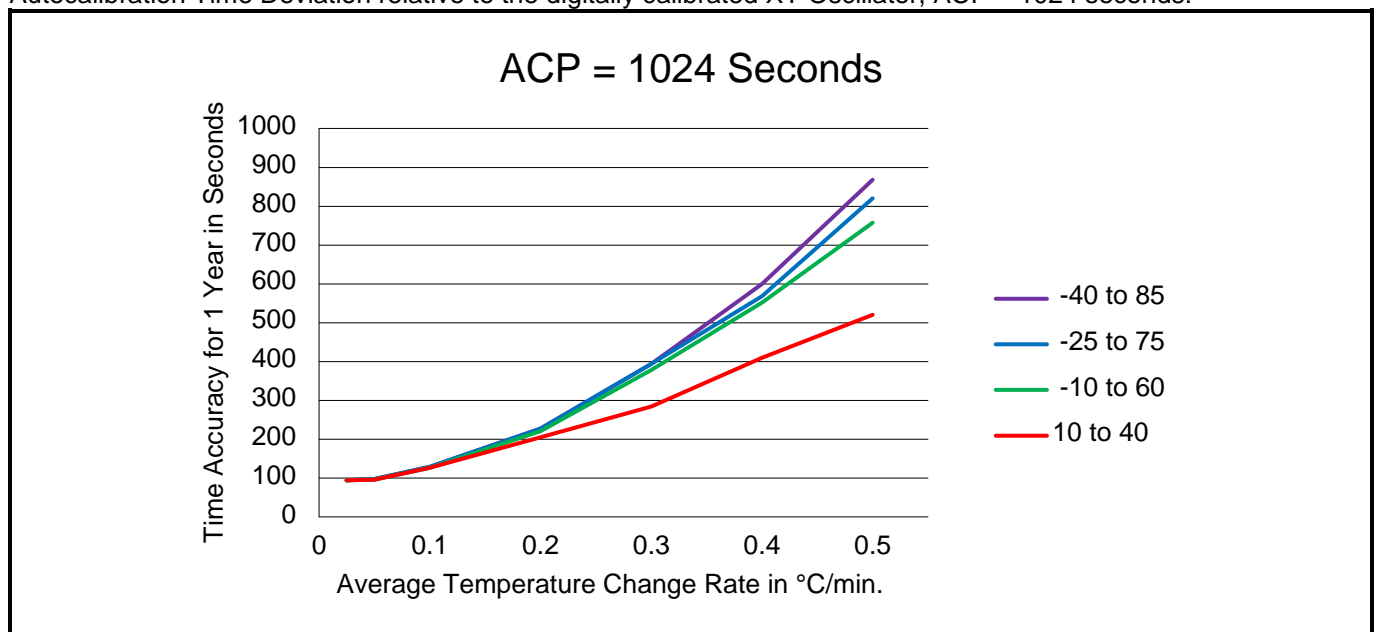

The deviations in both of the cases above for relatively low temperature change rates are less than the deviation introduced by the XT Oscillator itself. The following Figure shows the raw XT deviation, which is more strongly a function of the maximum temperature range than the calibrated RC deviation. The XT deviation is a similar function of the temperature change rate but is more influenced by the maximum temperature variation. Deviations in the XT Oscillator are larger when the temperature is further away from the nominal 25 degrees C, and therefore it is expected that the accumulated deviation will be greater if the temperature range is larger.

Raw Deviation, XT Oscillator:

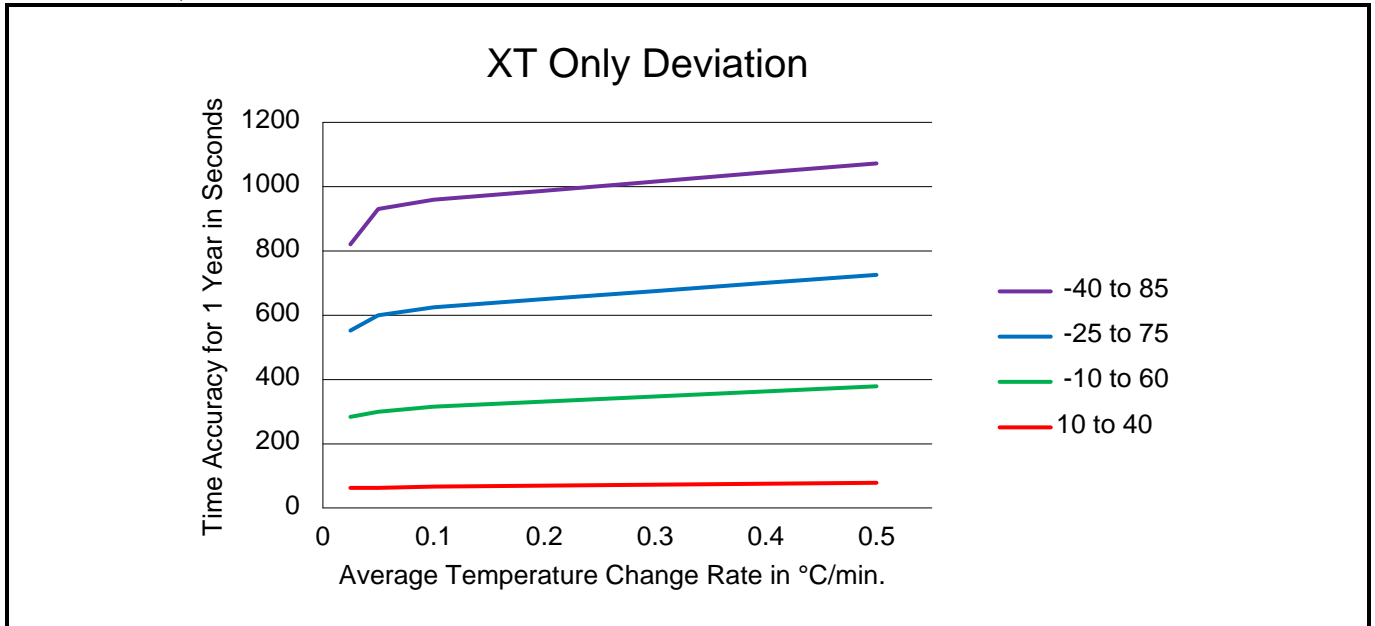

4.11.8. A REAL WORLD EXAMPLE

Even if the temperature occasionally reaches the extremes of the allowable range and changes relatively quickly, in most real applications the temperature is reasonably stable. A proposed “real world” temperature profile assumes that for 30 days per year the temperature has a maximum range of -25 to 75 degrees C and an average change rate of 1 degree C every 5 minutes (0.2 °C/min.). For the remainder of the year, the maximum temperature range is 10 to 40 degrees C with a maximum change rate of 1 degree C every 40 minutes (0.025 °C/min.). Using this profile, the accumulated deviations over the year (including the XT deviation in the calibrated RC cases) are shown in following Table. As can be seen, with an ACP of 512 the clock accuracy using Autocalibration is quite close to the deviation achieved by the XT alone. Extending to an ACP of 1024 seconds adds a small incremental deviation.

Real World Accumulated Deviations for 1 Year (1 ppm = 31.6 seconds in a year):

| Mode | Conditions | Accumulated Deviation | Unit |
|--------------------|----------------------------|-----------------------|----------|
| XT Only | Calibrated (0 ppm at 25°C) | -3.3 | ppm/year |
| | | -104 | s/year |
| RC Autocalibration | ACP = 512 seconds | ±6.1 | ppm/year |
| | | ±192 | s/year |
| | ACP = 1024 seconds | ±8.4 | ppm/year |
| | | ±245 | s/year |

4.11.9. RC AUTOCALIBRATION TIMING ACCURACY EXAMPLE

The RC Oscillator displays relatively high internal jitter caused by pulse addition or subtraction of the Autocalibration process as well as the inherent thermal noise jitter of the RC Oscillator itself. This jitter introduces significant time accuracy errors for short time periods.

The following Figure shows a typical Autocalibration mode timing accuracy for the time periods from 1 hour to 1 year relative to the digitally calibrated XT Oscillator, ACP = 512 seconds. The temperature does not vary. $T_A = 25^\circ\text{C}$, $V_{DD} = 3.0\text{V}$.

Autocalibration Mode Timing Accuracy Example:

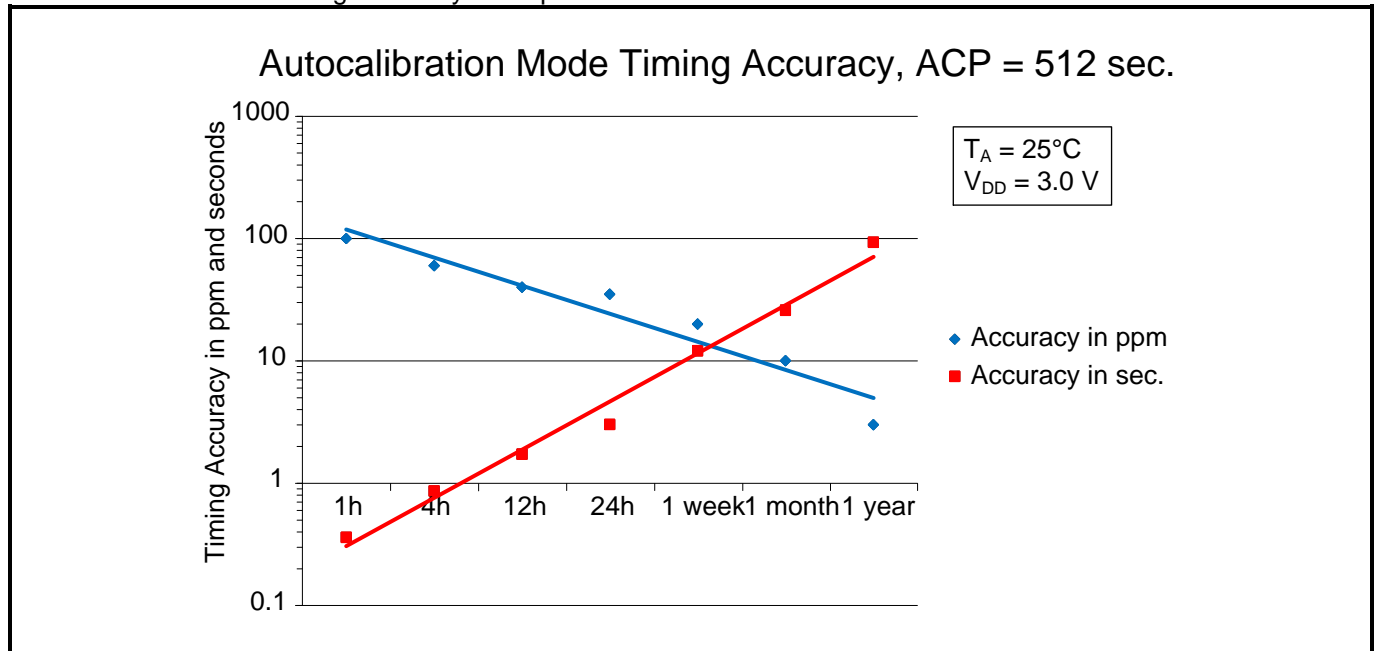

4.11.10. POWER ANALYSIS

The power comparisons between the various cases are quite straightforward. During an Autocalibration, the XT Oscillator is powered up for 50 seconds. Therefore if the RV-1805-C3 draws 60 nA when the XT Oscillator is running and 17 nA when the XT Oscillator is off, the average current for each ACP case is shown in the following Table. Even the shortest ACP results in a savings of more than 60% of the current.

Autocalibration Current ($T_A = 25^\circ\text{C}$, $V_{DD} = 3.0\text{V}$):

| | Average Current (nA) |
|----------------------------|----------------------|
| XT Only | 60 |
| Cal RC, ACP = 512 seconds | 22 |
| Cal RC, ACP = 1024 seconds | 19 |

4.11.11. DISADVANTAGES RELATIVE TO THE XT OSCILLATOR

Maximum Output Clock Frequency

The primary disadvantage of using the autocalibrated RC Oscillator is that the highest calibrated output clock frequency which can be generated is 64 Hz (i.e., circa the half of the uncalibrated RC Oscillator frequency). In applications where a higher frequency clock is required, the XT Oscillator must be used. If such a clock is required only occasionally, the RV-1805-C3 may be temporarily placed in XT Mode by setting the OSEL bit to 0, and then returned to RC Mode by setting OSEL back to 1 when the high frequency clock is no longer required. The RV-1805-C3 will continue to autocalibrate the RC Oscillator while the XT Oscillator is selected, but the calendar counters may gain or lose up to 1 second on each of the oscillator switchovers.

Large/Rapid Temperature Fluctuations

The XT Oscillator may also be preferable to Autocalibration when there are frequent, rapid and large temperature changes. In such a situation, the digitally calibrated XT Oscillator may provide a measurable improvement in accuracy, although at a significant power penalty relative to using Autocalibration.

Short Term Jitter

A third disadvantage of using the RC Oscillator is that it displays higher internal jitter relative to the XT oscillator. This jitter is caused by pulse addition or subtraction of the Autocalibration process as well as the inherent thermal noise jitter of the RC Oscillator itself. This jitter may introduce significant frequency errors over short time periods. In both cases the mean of the jitter is zero, and the following Table shows the standard deviation of the clock period for several short time periods including both jitter and temperature effects. A typical worst case metric is 4 standard deviations, which covers approximately 99.99% of all cases.

Short Term Jitter Standard Deviation:

| Time Interval | Std. Dev. (ppm) | Std. Dev. (ms) |
|---------------|-----------------|----------------|
| 0.5 hours | 90.9 | 163.6 |
| 1 hour | 45.5 | 163.8 |
| 2 hours | 32.3 | 232.6 |
| 4 hours | 22.5 | 324.0 |
| 1 day | 9.3 | 803.5 |
| 2 days | 6.5 | 1123.2 |
| 3 days | 5.3 | 1373.8 |
| 1 week | 3.5 | 2116.8 |

4.12. XT OSCILLATOR FAILURE DETECTION

If the 32.768 kHz XT Oscillator generates clocks at less than 8 kHz for a period of more than 32 ms, the RV-1805-C3 detects an XT Oscillator Failure. The XT Oscillator Failure function is controlled by several bits in the OSCILLATOR REGISTERS (see 1Ch Oscillator Control and 1Dh - Oscillator Status Register). The OF flag is set when an XT Oscillator Failure occurs, and is also set when the RV-1805-C3 initially powers up. If the OFIE bit is set, the OF flag will generate an interrupt OFIRQ.

If the FOS bit is set and the RV-1805-C3 is currently using the XT Oscillator, it will automatically switch to the RC Oscillator on an XT Oscillator Failure. This guarantees that the system clock will not stop in any case. The OMODE bit indicates the currently selected oscillator, which will not match the oscillator requested by the OSEL bit if the XT Oscillator is not running.

The OF flag will be set when the RV-1805-C3 powers up, and will also be set whenever the XT Oscillator is stopped. This can happen when the STOP bit is set or the OSEL bit is set to 1 to select the RC Oscillator. Since the XT Oscillator is stopped in RC Autocalibration mode (see RC AUTOCALIBRATION MODE), OF will always be set in this mode. The OF flag should be cleared whenever the XT Oscillator is enabled prior to enabling the OF interrupt with OFIE.

4.13. INTERRUPTS

The RV-1805-C3 may generate a variety of interrupts which are ORed into the IRQ signal. This may be driven onto either the CLK/ $\overline{\text{INT}}$ pin or the PSW pin depending on the configuration of the CLKS and PSWS fields (see CONFIGURATION REGISTERS, 11h - Control2).

4.13.1. INTERRUPT SUMMARY

The possible interrupts are summarized in the following Table. All enabled interrupts are ORed into the IRQ signal when their respective flags are set. Note that most interrupt outputs use the inverse of the interrupt, denoted as e.g. inverse IRQ. The fields are:

- Interrupt - the name of the specific interrupt.
- Function - the functional area which generates the interrupt.
- Enable - the register bit which enables the interrupt. Note that for the Watchdog interrupt, WDS is the steering bit, so that the flag generates an Interrupt if WDS is 0 and a Reset if WDS is 1. In either case, the WDM field must be non-zero to generate the Interrupt or Reset.
- Pulse/Level/Repeat - some interrupts may be configured to generate a pulse based on the register bits in this column. "Level Only" implies that only a level may be generated, and the interrupt will only go away when the flag is reset by software.
- Flag - the register bit which indicates that the function has occurred. Note that the flag being set will only generate an interrupt signal on an external pin if the corresponding interrupt enable bit is also set.

| Interrupt | Function | Enable | Pulse/Level/Repeat | Flag |
|---|--------------------------|------------------|--------------------|------|
| AIRQ | Alarm Match | AIE | IM, ARPT | AF |
| TIRQ | Countdown Timer | TIE, TE | TM, TRPT, TFS | TF |
| WIRQ | Watchdog Timer (WDI) | WDS = 0, WDM, WD | Level Only | WDF |
| BLIRQ | Battery Low | BLIE, BREF, BPOL | Level Only | BLF |
| EIRQ | External Interrupt (WDI) | EIE, EIP | Level Only | EVF |
| OFIRQ | XT Oscillator Failure | OFIE | Level Only | OF |
| ACIRQ | Autocalibration Failure | ACIE | Level Only | ACF |
| IRQ = AIRQ + TIRQ + WIRQ + BLIRQ + EIRQ + OFIRQ + ACIRQ | | | | |

4.13.2. ALARM INTERRUPT AIRQ

The RV-1805-C3 may be configured to generate the AIRQ interrupt when the values in the Time and Date Registers match the values in the Alarm Registers. Which register comparisons are required to generate AIRQ is controlled by the ARPT field as described in TIMER REGISTERS, 18h - Countdown Timer Control, allowing software to specify the interrupt interval. When an Alarm Interrupt is generated, the AF flag is set and an output signal is generated based on the AIE bit and the pin configuration settings. The IM field controls the period of the signal, including both level and pulse configurations.

4.13.3. COUNTDOWN TIMER INTERRUPT TIRQ

The RV-1805-C3 may be configured to generate the TIRQ interrupt when the Countdown Timer is enabled by the TE bit and reaches the value of zero, which will set the TF flag. The TM, TRPT and TFS fields control the interrupt timing (see TIMER REGISTERS, 18h - Countdown Timer Control), and the TIE bit and the pin configuration settings control the output signal generation.

4.13.4. WATCHDOG TIMER INTERRUPT WIRQ

The RV-1805-C3 may be configured to generate the WIRQ interrupt when the Watchdog Timer reaches its timeout value. This sets the WDF flag and is described in section WATCHDOG TIMER.

4.13.5. BATTERY LOW INTERRUPT BLIRQ

The RV-1805-C3 may be configured to generate the BLIRQ when the voltage on the V_{BACKUP} pin crosses one of the thresholds set by the BREF field. The polarity of the detected crossing is set by the BPOL bit.

4.13.6. EXTERNAL INTERRUPT EIRQ

The RV-1805-C3 may be configured to generate the EIRQ interrupt when the WDI input toggles. The register bit EIP control whether the rising or falling transitions generate the respective interrupt. Changing EIP may cause an immediate interrupt, so the interrupt flag should be cleared after changing this bit.

The value of the WDI pin may be directly read in the WDIS bit (see RAM REGISTERS, 3Fh - Extension RAM Address). By connecting the input such as a pushbutton to WDI, software can debounce the switch input using software configurable delays.

4.13.7. XT OSCILLATOR FAILURE INTERRUPT OFIRQ

The RV-1805-C3 may be configured to generate the OFIRQ interrupt if the XT oscillator fails (see XT OSCILLATOR FAILURE DETECTION).

4.13.8. AUTOCALIBRATION FAILURE INTERRUPT ACIRQ

The RV-1805-C3 may be configured to generate the ACIRQ interrupt if an Autocalibration operation fails (see AUTOCALIBRATION FAIL).

4.13.9. SERVICING INTERRUPTS

When an interrupt is detected, software must clear the interrupt flag in order to prepare for a subsequent interrupt. If only a single interrupt is enabled, software may simply write a zero to the corresponding interrupt flag to clear the interrupt. However, because all of the flags in the Status register are written at once, it is possible to clear an interrupt which has not been detected yet if multiple interrupts are enabled. The ARST register bit is provided to insure that interrupts are not lost in this case. If ARST is a 1, a read of the Status register will produce the current state of all the interrupt flags in the Status register (WDF, BLF, TF, AF and EVF) and then clear them. An interrupt occurring at any time relative to this read is guaranteed to either produce a 1 on the Status read, or to set the corresponding flag after the clear caused by the Status read. After servicing all interrupts which produced 1s (ones) in the read, software should read the Status register again until it returns all zeros in the flags, and service any interrupts with flags of 1.

Note that the OF and ACF interrupts are not handled with this process because they are in the Oscillator Status register, but error interrupts are very rare and typically do not create any problems if the interrupts are cleared by writing the flag directly.

4.14. POWER CONTROL AND SWITCHING

The main power supply to the RV-1805-C3 is the V_{DD} pin, which operates over the range specified by the V_{DDIO} parameter if there are I²C interface operations required, and the range specified by the V_{DD} parameter if only timekeeping operations are required. The RV-1805-C3 also include a backup supply which is provided on the V_{BACKUP} pin and must be in the range specified by the V_{BACKUP} parameter in order to supply battery power if V_{DD} is below V_{DDSWF} . Refer to Table in Section POWER SUPPLY PARAMETERS for the specifications related to the power supplies and switchover. There are several functions which are directly related to the V_{BACKUP} input. If a single power supply is used it must be connected to the V_{DD} pin.

The following Figure illustrates the various power states and the transitions between them. There are three power states:

1. POR – the power on reset state. If the RV-1805-C3 is in this state, all registers including the Counter Registers are initialized to their reset values.
2. VDD Power – the RV-1805-C3 is powered from the V_{DD} supply.
3. VBACKUP Power – the RV-1805-C3 is powered from the V_{BACKUP} supply.

Initially, V_{DD} is below the V_{DDST} voltage, V_{BACKUP} is below the $V_{BACKUPSW}$ voltage and the RV-1805-C3 is in the POR state. V_{DD} rising above the V_{DDST} voltage causes the RV-1805-C3 to enter the VDD Power state. If V_{BACKUP} remains below $V_{BACKUPSW}$, V_{DD} falling below the V_{DDRST} voltage returns the RV-1805-C3 to the POR state.

Power States:

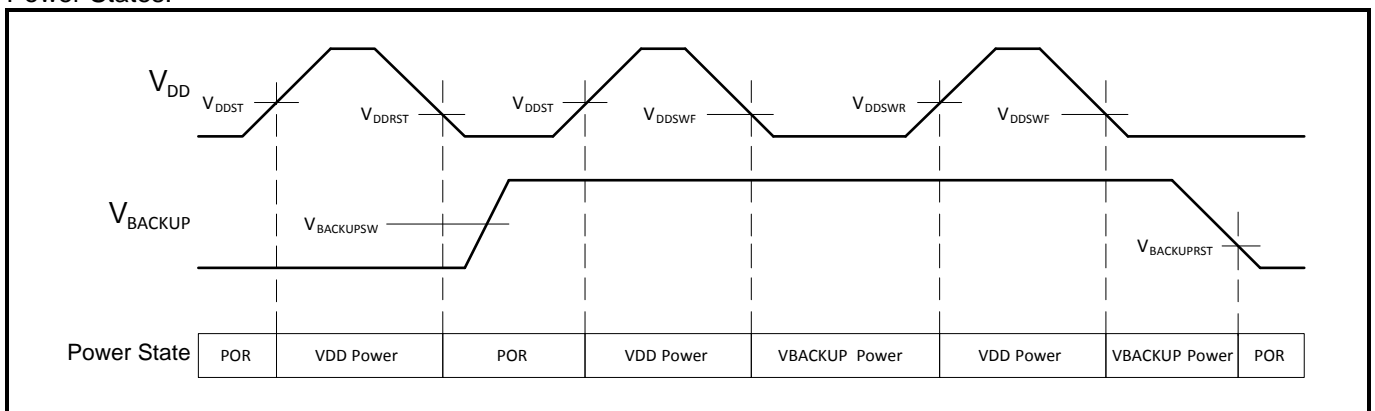

If V_{BACKUP} rises above $V_{BACKUPSW}$ in the POR state, the RV-1805-C3 remains in the POR state. This allows the RV-1805-C3 to be built into a module with a battery included, and minimal current will be drawn from the battery until V_{DD} is applied to the module the first time.

If the RV-1805-C3 is in the VDD Power state and V_{BACKUP} rises above V_{BACKUPSW} , the RV-1805-C3 remains in the VDD Power state but automatic switchover becomes available. V_{BACKUP} falling below V_{BACKUPSW} has no effect on the power state as long as V_{DD} remains above V_{DDSWF} . If V_{DD} falls below the V_{DDSWF} voltage while V_{BACKUP} is above V_{BACKUPSW} the RV-1805-C3 switches to the VBACKUP Power state. V_{DD} rising above V_{DDSWR} returns the RV-1805-C3 to the VDD Power state. There is hysteresis in the rising and falling V_{DD} thresholds to insure that the RV-1805-C3 does not switch back and forth between the supplies if V_{DD} is near the thresholds. V_{DDSWF} and V_{DDSWR} are independent of the V_{BACKUP} voltage and allow the RV-1805-C3 to minimize the current drawn from the V_{BACKUP} supply by switching to V_{BACKUP} only at the point where V_{DD} is no longer able to power the device.

If the RV-1805-C3 is in the VBACKUP Power state and V_{BACKUP} falls below $V_{\text{BACKUPRST}}$, the RV-1805-C3 will return to the POR state.

Whenever the RV-1805-C3 enters the VBACKUP Power state, the BAT status bit (Read Only) (see CONFIGURATION REGISTERS, 0Fh - Status) is set and may be polled by software if the I²C bus is driven by V_{BACKUP} . If the XT oscillator is selected and the BOS bit is set (see OSCILLATOR REGISTERS, 1Ch - Oscillator Control), the RV-1805-C3 will automatically switch to the RC oscillator in the VBACKUP Power state in order to conserve battery power (Autocalibration Mode according to the ACAL field). If the IOBM bit is clear (see ANALOG CONTROL REGISTERS, 27h – IO Batmode Register), the I²C interface is disabled in the VBACKUP Power state in order to prevent erroneous accesses to the RV-1805-C3 if the bus master loses power.

4.14.1. AUTOMATIC SWITCHOVER SUMMARY

When the RV-1805-C3 switches over from VDD Power state to the VBACKUP Power state and vice versa an Automatic Oscillator Switchover can be controlled by the BOS bit. The Autocalibration Mode is according to the ACAL field.

Automatic Oscillator Switchover using the BOS bit:

| BOS | Used oscillator | | Description |
|-----|--------------------|---------------------|--|
| | VDD Power state | VBACKUP Power state | |
| 0 | RC | RC | No automatic oscillator switching occurs. |
| | RC Autocalibration | RC Autocalibration | |
| | XT | XT | |
| | XT Autocalibration | XT Autocalibration | |
| 1 | RC | RC | The oscillator will automatically switch to the RC oscillator (Autocalibration Mode according ACAL). |
| | RC Autocalibration | RC Autocalibration | |
| | XT | RC | |
| | XT Autocalibration | RC Autocalibration | |

When using the FOS bit to control the switchover, an Automatic Oscillator Switchover occurs when a XT oscillator failure is detected and FOS is set to 1.

4.14.2. BATTERY LOW FLAG AND INTERRUPT

If the V_{BACKUP} voltage drops below the Falling Threshold selected by the BREF field (see ANALOG CONTROL REGISTERS, 21h – BREF Control), the BLF flag (see CONFIGURATION REGISTERS, 0Fh - Status) is set. If the BLIE interrupt enable bit (see CONFIGURATION REGISTERS, 12h - Interrupt Mask) is set, the BLIRQ interrupt is generated. This allows software to determine if a backup battery has been drained. Note that the BPOL bit must be set to 0. The algorithm in the ANALOG COMPARATOR section should be used when configuring the BREF value.

If the V_{BACKUP} voltage is above the rising voltage which corresponds to the current BREF setting, BREFD will be set. At that point the V_{BACKUP} voltage must fall below the falling voltage in order to clear the BREFD bit and the BAT status bit is set and a falling edge BLF interrupt is generated. If BREFD is clear, the V_{BACKUP} voltage must rise above the rising voltage in order to clear the BREFD bit and generate a rising edge BLF interrupt.

4.14.3. ANALOG COMPARATOR

If a backup battery is not required, the V_{BACKUP} pin may be used as an analog comparator input. The voltage comparison level is set by the BREF field. If the BPOL bit is 0, the BLF flag will be set when the V_{BACKUP} voltage crosses from above the BREF Falling Threshold to below it. If the BPOL bit is 1, the BLF flag will be set when the V_{BACKUP} voltage crosses from below the BREF Rising Threshold to above it. The BREFD bit (see ANALOG CONTROL REGISTERS, 2Fh – Analog Status Register (Read Only)) may be read to determine if the V_{BACKUP} voltage is currently above the BREF threshold (BREFD = 1) or below the threshold (BREFD = 0).

There is a reasonably large delay t_{BREF} (on the order of seconds) between changing the BREF field and a valid value of the BREFD bit. Therefore, the algorithm for using the Analog Comparator should comprise the following steps:

1. Set the BREF and BPOL fields to the desired values.
2. Wait longer than the maximum t_{BREF} time.
3. Clear the BLF flag, which may have been erroneously set as BREFD settles.
4. Check the BREFD bit to insure that the V_{BACKUP} pin is at a level for which an interrupt can occur. If a falling interrupt is desired (BPOL = 0), BREFD should be 1. If a rising interrupt is desired (BPOL = 1), BREFD should be 0.

If the comparison voltage on the V_{BACKUP} pin can remain when V_{DD} goes to 0, it is recommended that a Software Reset is generated to the RV-1805-C3 after power up.

4.14.4. PIN CONTROL AND LEAKAGE MANAGEMENT (POWER CONTROL)

Like most ICs, the RV-1805-C3 may draw unnecessary leakage current if an input pin floats to a value near the threshold or an output pin is pulled to a power supply. Because external devices may be powered from V_{DD} , extra care must be taken to insure that any input or output pins are handled correctly to avoid extraneous leakage when V_{DD} goes away and the RV-1805-C3 is powered from V_{BACKUP} . The 30h – Output Control Register (see ANALOG CONTROL REGISTERS), the 27h – IO Batmode Register (see ANALOG CONTROL REGISTERS) and the 3Fh - Extension RAM Address register (see RAM REGISTERS) include bits to manage this leakage, which should be used as follows:

1. IOBM (Bit 7, address 27h) should be cleared if the I²C bus master is powered down when the RV-1805-C3 is in the VBACKUP Power state.
2. WDBM (Bit 7, address 30h) should be cleared if the WDI pin is connected to a device which is powered down when the RV-1805-C3 is in the VBACKUP Power state.
3. X (Bit 6, address 30h) is unused, but has to be 0 to avoid extraneous leakage. Disables an internal input when the RV-1805-C3 is in the VBACKUP Power state.
4. X (Bit 7, address 3Fh) is unused, but must be set to 0 to avoid extraneous leakage. If 0, an internal output is completely disconnected when the RV-1805-C3 is in the VBACKUP Power state.

4.14.5. POWER UP TIMING

When the voltage levels on both the V_{DD} and V_{BACKUP} signals drop below V_{DDRST} , the RV-1805-C3 will enter the Power On Reset state (POR). Once V_{DD} rises above V_{DDST} , the RV-1805-C3 will enter the VDD Power state. The access via the I²C interface will be disabled for a period of $t_{VH:CLK}$. The CLK/INT pin will be low at power up, and will go high when $t_{VH:CLK}$ expires. Software should poll the CLK/INT value to determine when the RV-1805-C3 may be accessed. The following Figure illustrates the timing of a power down/up operation.

Power Up Timing:

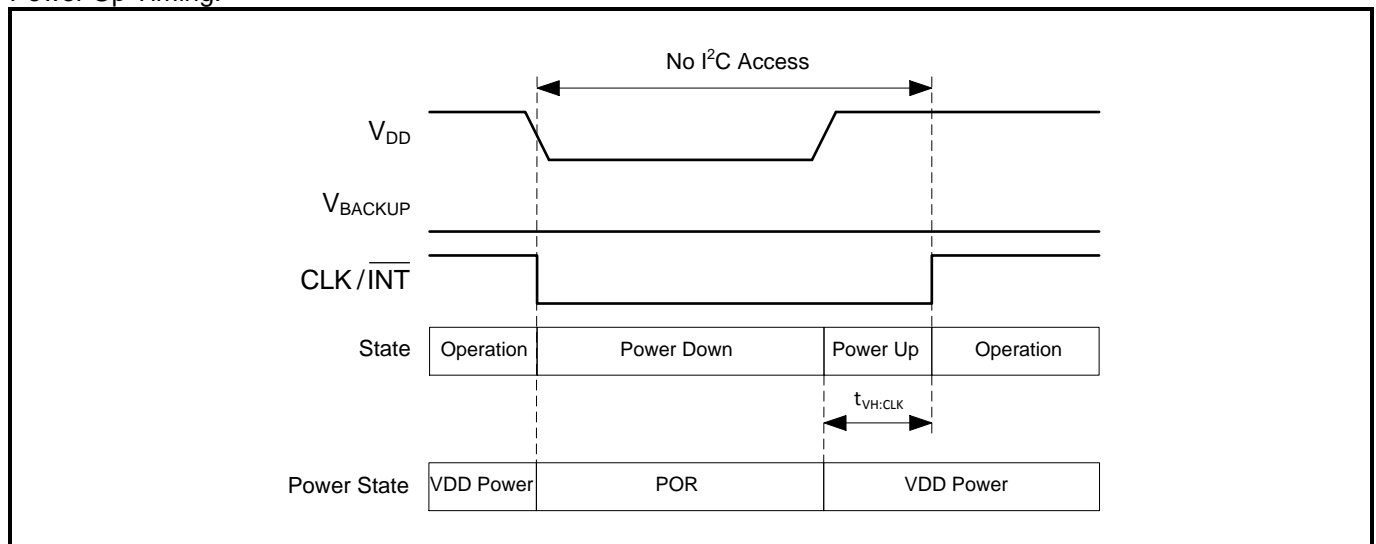

4.15. RESET SUMMARY

The RV-1805-C3 controls the \overline{RST} output in a variety of ways, as shown in the following Table. The assertion of \overline{RST} is a low signal if the RSTP bit is 0, and the assertion is high if RSTP is 1. RSTP always powers up as a zero so that on power \overline{RST} is always asserted low.

Reset Summary:

| Function | Enable |
|----------|----------------|
| Power Up | Always Enabled |
| Watchdog | WDS |
| Sleep | SLRST |

4.15.1. POWER UP RESET

When the RV-1805-C3 powers up (see POWER UP TIMING) $\overline{\text{CLK/INT}}$ and $\overline{\text{RST}}$ will be asserted low until I²O accesses are enabled. At that point $\overline{\text{CLK/INT}}$ will go high, and $\overline{\text{RST}}$ will continue to be asserted low for the delay $t_{\text{VH:NRST}}$, and will then be deasserted to high. The following Figure illustrates the reset timing on Power Up. Software should sample the $\overline{\text{CLK/INT}}$ signal prior to accessing the RV-1805-C3.

Power Up Reset Timing:

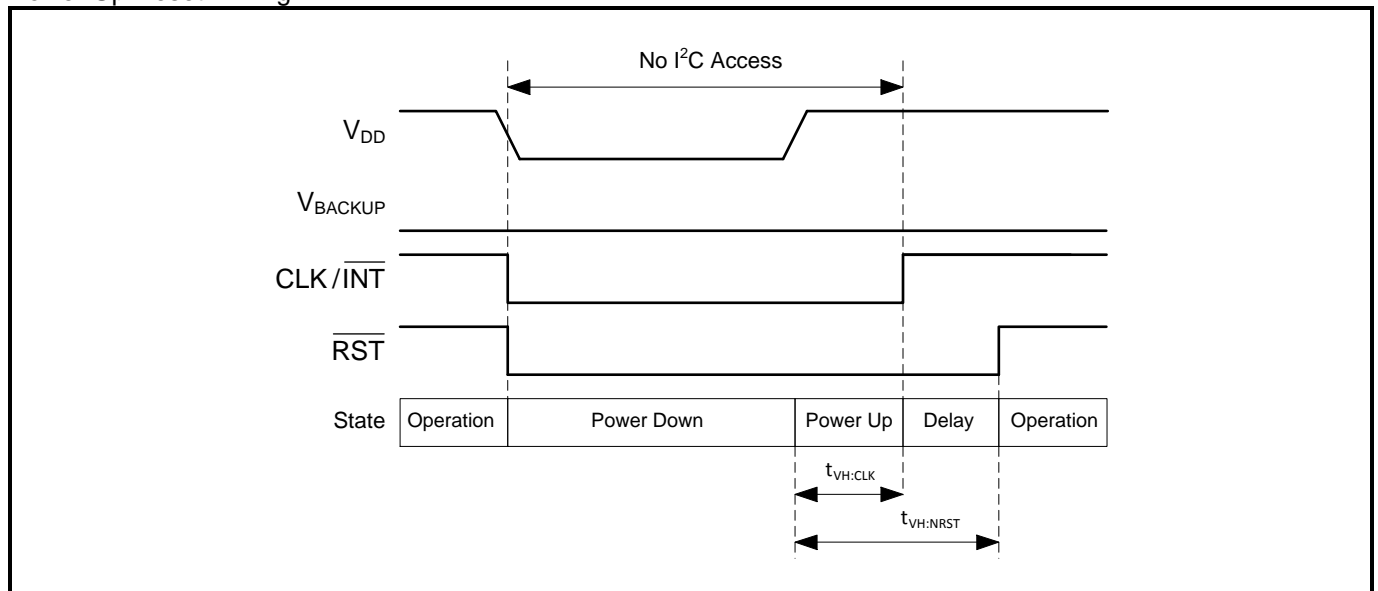

4.15.2. WATCHDOG TIMER

If the WDS bit is 1, expiration of the Watchdog Timer (see WATCHDOG TIMER) will cause $\overline{\text{RST}}$ to be asserted low for approximately 60 ms.

4.15.3. SLEEP

If the SLRST bit is set, $\overline{\text{RST}}$ will be asserted low whenever the RV-1805-C3 is in Sleep Mode (see SLEEP CONTROL). Once a trigger is received and the RV-1805-C3 exits Sleep Mode, $\overline{\text{RST}}$ will continue to be asserted low for the $t_{\text{VH:NRST}}$ delay. The following Figure illustrates the timing of this operation.

Sleep Reset Timing:

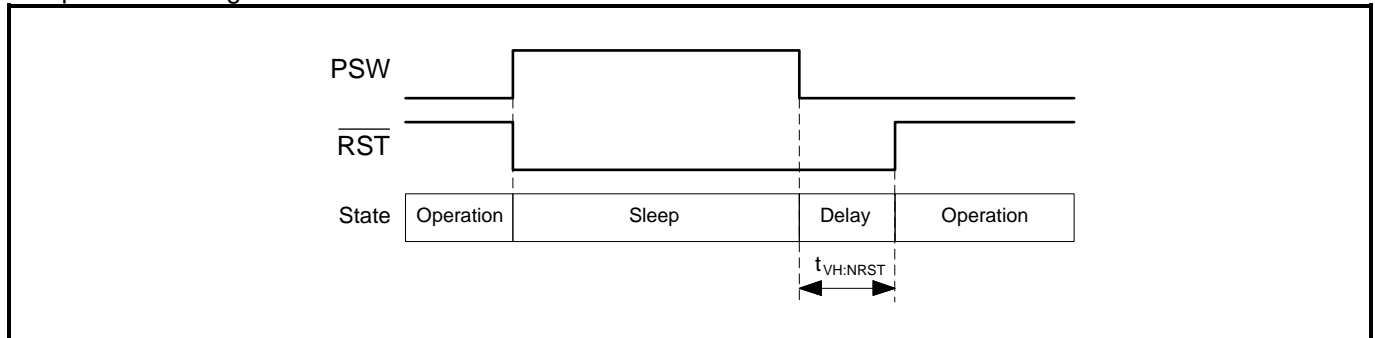

4.16. SOFTWARE RESET

Software may reset the RV-1805-C3 by writing the special value of 3Ch to the Configuration Key CONFKEY at register address 1Fh. This will provide the equivalent of a power on reset (POR) by initializing all of the RV-1805-C3 registers. A software reset will not cause the $\overline{\text{RST}}$ signal to be asserted low.

4.17. SLEEP CONTROL STATE MACHINE

The RV-1805-C3 includes a sophisticated Sleep Control system that allows the RV-1805-C3 to manage power for other chips in a system. The Sleep Control system provides two outputs which may be used for system power control:

1. A reset ($\overline{\text{RST}}$) may be generated to put any host controller into a minimum power mode and to control sequencing during power up and power down operations.
2. A power switch signal (PSW) may be generated, which allows the RV-1805-C3 to completely power down other chips in a system by allowing the PSW pin to float. The PSWS field must be set to a value of 6 to select the SLEEP signal.
 - a. When setting PSWC bit to 1 (default value), PSW is configured as an open drain pin with approximately 1 Ω resistance. This allows the RV-1805-C3 to directly switch power with no external components for small systems, or to control a single external transistor for higher current switching. If the I²C master (i.e., the host controller) is powered down by the power switch, the IOPW bit should be set to insure that a floating bus does not corrupt the RV-1805-C3.
 - b. When setting PSWC bit to 0, PSW will be configured as a high true Sleep state which may be used as an interrupt.

The Sleep Control State Machine in the Figure in Section SLEEP STATE receives several inputs which it uses to determine the current Sleep State:

1. $\overline{\text{POR}}$ - the indicator that power on reset state is finished and power is valid, i.e. the RV-1805-C3 is in either the VDD Power state or the VBACKUP Power state.
2. SLP - the Sleep Request signal which is generated by a software access to the bit SLP.
3. VAL - the OR of the enabled valid interrupt request from the Alarm comparison, Countdown Timer, Watchdog Timer and External Interrupt (WDI pin). The Battery Low detection interrupt, the Autocalibration Failure interrupt and the XT Oscillator Failure interrupt are not integrated to the internal VAL information but also ORed to the internal IRQ signal.
4. TF - the timeout signal from the Countdown Timer, indicating that it has decremented to 0.

4.17.1. RUN STATE

RUN is the normal operating state of the RV-1805-C3. PSW is 0, $\overline{\text{RST}}$ is 1, SLP is 0, and SLF flag holds the state of the previous Sleep. The SLF flag should be cleared by software before entering the SWAIT state.

4.17.2. SWAIT STATE (SLEEP_WAIT STATE)

Software can put the chip to sleep by setting the SLP bit, as long as a valid interrupt is enabled (indicated by the internal status signal VAL being asserted high) (see SLP PROTECTION). If the SLW field is between 1 and 7 the Sleep Control State Machine moves to the SWAIT state and waits for between SLW and (SLW+1) times the ~8 ms periode. This allows software to perform additional cleanup functions after setting SLP before the MCU is shut down. Operation is the same in SWAIT as it is in RUN, and if an enabled operational interrupt occurs (combined interrupt signal IRQ) the Sleep Control State Machine returns to the RUN state and clears the SLP bit. PSW stay at 0, $\overline{\text{RST}}$ stay at 1 and the SLF flag is still 0.

If SLW is set to 0, the Sleep Control State Machine moves immediately to the SLEEP state. If the MCU is configured to be powered down in Sleep Mode, the I²C operation to write the Sleep Register must be the last instruction executed by the MCU.

4.17.3. SLEEP STATE

Once the programmed number of periods has elapsed in the SWAIT state, the TF signal is asserted and the machine moves to the SLEEP state, putting the RV-1805-C3 into Sleep Mode. In this case PSW is asserted high, and $\overline{\text{RST}}$ is asserted low if SLRST = 1. Once an enabled operational interrupt occurs (combined interrupt signal IRQ), the Sleep Control State Machine returns to the RUN state, re-enables power and removes reset as appropriate. The SLF flag in the Sleep Register is set when the SLEEP state is entered, allowing software to determine if a SLEEP has occurred.

Sleep Control State Machine:

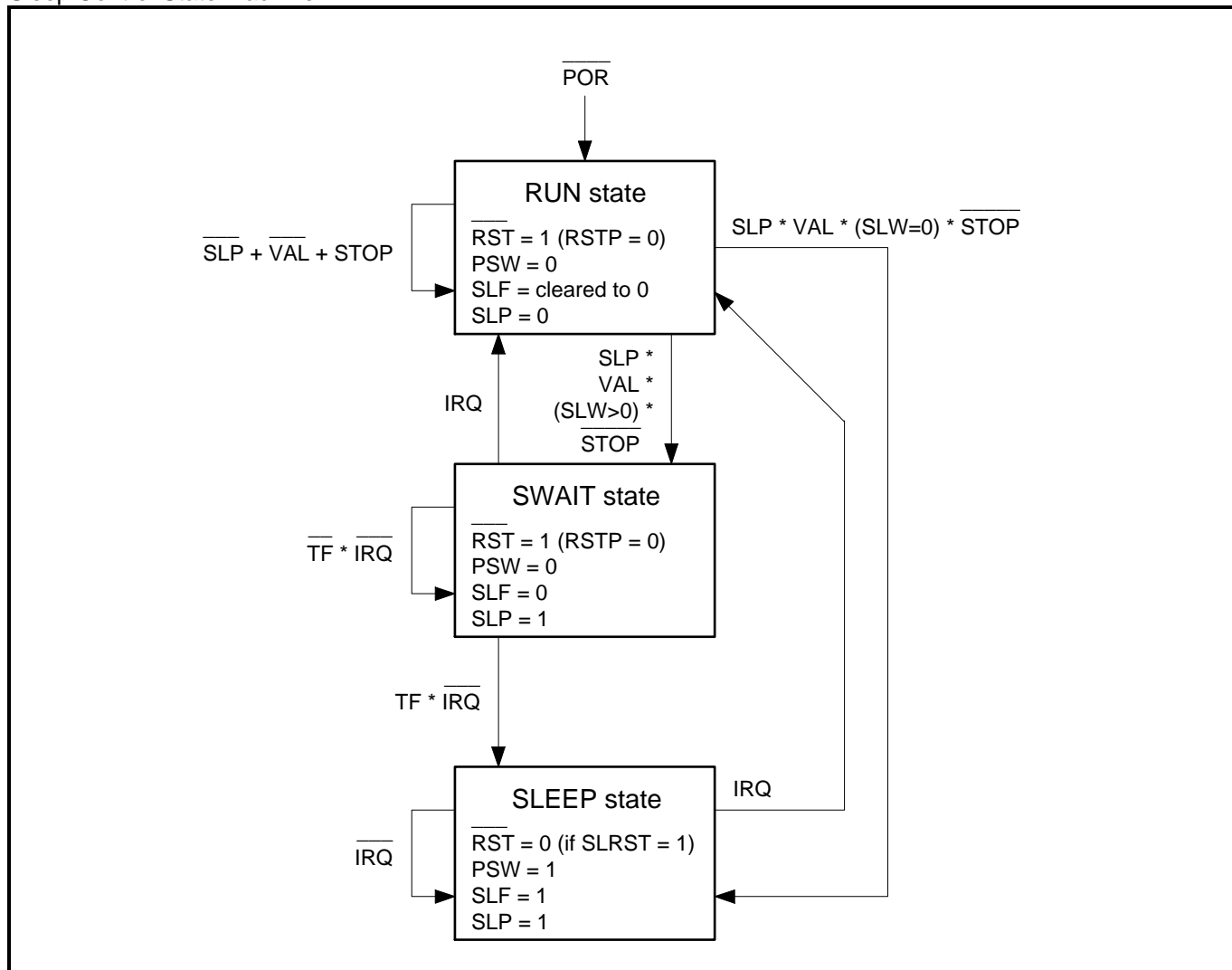

Interrupt functions

VAL: Minimum one valid interrupt is enabled (internal status signal).
 IRQ: An enabled interrupt occurs (internal combined interrupt signal).

Bits and fields

SLP bit: Sleep Request signal
 SLW field: Number of ~8 ms waiting periods
 STOP bit: Stops clocking system
 SLF bit: Flag is set when the RV-1805-C3 enters SLEEP state. Can be cleared by software.
 TF bit: Countdown Timer Flag. Set when timer reaches zero.

Outputs

RST pin
 PSW pin

+ logic OR
 * logic AND

4.17.4. SLP PROTECTION

Since going into Sleep Mode may prevent an MCU from accessing the RV-1805-C3, it is critical to insure that the RV-1805-C3 can receive an interrupt signal (combined interrupt signal IRQ). To guarantee this, the SLP signal cannot be set unless the STOP bit is 0 and at least one of the following interrupt functions are enabled (sets the internal status signal VAL to 1):

1. The AIE bit is 1, enabling an Alarm interrupt.
2. The TIE and the TE bits are 1, enabling a Countdown Timer interrupt.
3. The EIE bit is 1, enabling the External interrupt.
4. The WDM field is not zero and the WDS bit is zero, enabling a Watchdog Interrupt.

In addition, SLP cannot be set if there is an interrupt pending. Software should read the SLP bit after attempting to set it. If SLP is not asserted, the attempt to set SLP was unsuccessful either because a correct trigger was not enabled or because an interrupt was already pending. Once SLP is set, software should continue to poll it until the Sleep actually occurs, in order to handle the case where a trigger occurs before the RV-1805-C3 enters Sleep Mode.

4.17.5. PSWS, PSWB AND LKP

If the PSWS field is set to the initial value of 7, the PSW pin will be driven with the static value of the PSWB bit which is initially zero. If this pin is used as the power switch, setting PSWB will remove power from the system and may prevent further access to the RV-1805-C3. In order to insure that this does not happen inadvertently, the LKP bit must be cleared in order to change the PSWB bit to a 1.

Note that in this power switch environment the PSWS register field must not be written to any value other than 6 or 7, even if the PSW pin would remain at zero, because it is possible that a short high pulse could be generated on the PSW pin which could create a power down.

4.17.6. PIN CONTROL AND LEAKAGE MANAGEMENT (SLEEP CONTROL)

Like most ICs, the RV-1805-C3 may draw unnecessary leakage current if an input pin floats to a value near the threshold or an output pin is pulled to a power supply. Because Sleep Mode can power down external devices connected to the RV-1805-C3, extra care must be taken to insure that any input or output pins are handled correctly to avoid extraneous leakage. The Output Control register includes bits to manage this leakage, which should be used as follows:

1. CLKSL (Bit 0, address 30h) should be cleared if the $\overline{\text{CLK/INT}}$ pin is connected to a device which is powered down in Sleep Mode.
2. RSTSL (Bit 3, address 30h) should be cleared if the $\overline{\text{RST}}$ pin is connected to a device which is powered down in Sleep Mode.
3. WDDS (Bit 5, address 30h) should be set if the WDI pin is connected to a device which is powered down in Sleep Mode.
4. X (Bit 1, address 30h) is unused, but has to be 0 to avoid extraneous leakage. If 0, an internal output is completely disconnected when the RV-1805-C3 is in Sleep Mode.
5. X (Bit 2, address 30h) is unused, but has to be 0 to avoid extraneous leakage. If 0, an internal output is completely disconnected when the RV-1805-C3 is in Sleep Mode.
6. X (Bit 4, address 30h) is unused, but must be set to 1 to avoid extraneous leakage. Disables an internal input when the RV-1805-C3 is in Sleep Mode.

The Oscillator Control register includes a bit to manage the I²C interface:

7. IOPW (Bit 2, address 1Ch) must be set to 1 to avoid extraneous leakage. If 1, the I²C interface pins are disabled in Sleep Mode. This is a particularly important function because there are multiple leakage paths in the I²C interface.

4.18. SYSTEM POWER CONTROL APPLICATIONS

In addition to fundamentally low power RTC operation, the RV-1805-C3 includes the capability to effectively manage the power of other devices in a system. It allows the creation of extremely power efficient systems with minimal additional components. This configuration is typically used when the entire system is powered from a battery.

4.18.1. V_{SS} POWER SWITCHED

The following Figure illustrates the recommended implementation, in which the internal power switch of the RV-1805-C3 is used to completely turn off the MCU and/or other system elements. In this case the PSW output is configured to generate the system sleep function, the PSWC bit is asserted to high and the SLRST bit is set to 0. Under normal circumstances, the PSW pin is pulled to V_{SS} with approximately 1 Ω of resistance, so that the MCU receives full power. The MCU initiates a sleep operation by setting SLP to 1, and when the RV-1805-C3 enters the SLEEP state the PSW pin is opened and power is completely removed from the MCU. This results in significant additional power savings relative to the other alternatives because even very low power MCUs require more current in their lowest power state than the RV-1805-C3.

The RV-1805-C3 normally powers up selecting the PSWB bit to drive the PSW pin, and the default value of the PSWB bit is zero. This insures that the power switch is enabled at power up. If the power switch function is used, software should only change the PSW selection between PSWB (111b) and SLEEP (110b) to insure no glitches occur in the power switching function.

Switched V_{SS} Power Control:

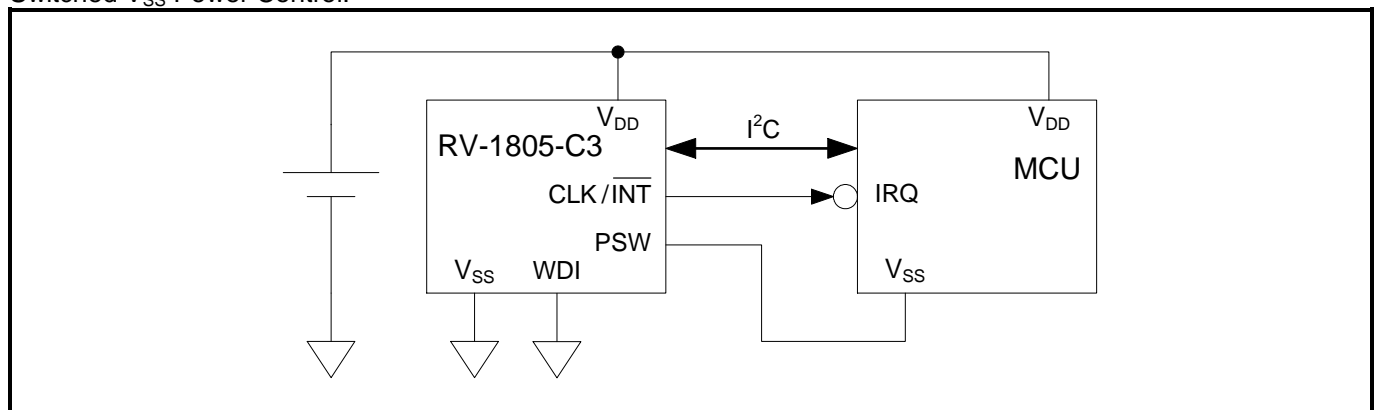

4.18.2. V_{DD} POWER SWITCHED

The following Figure illustrates the application in which an external transistor switch T is used to turn off power to the MCU. The SLP function operates identically to the V_{SS} switched case above, but this implementation allows switching higher current and maintains a common ground. R can be on the order of megohms, so that negligible current is drawn when the circuit is active and PSW is low.

Switched V_{DD} Power Control:

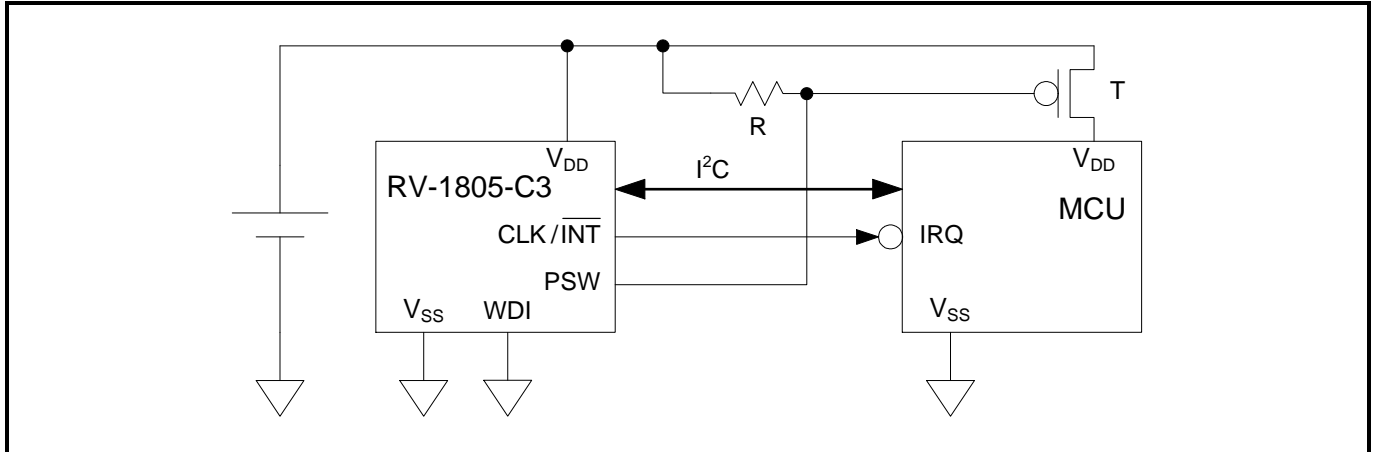

4.18.3. RESET DRIVEN

The following Figure illustrates the application in which the RV-1805-C3 communicates with the system MCU using the reset function. In this case the MCU sets the SLRST bit so that when the RV-1805-C3 enters the SLEEP state, it brings \overline{RST} low to reset the MCU, and initiates a sleep operation. When the trigger occurs, the RV-1805-C3 releases the MCU from reset, and may also generate an interrupt which the MCU can query to determine how reset was exited. Since some MCUs use much less power when reset, this implementation can save system power.

Reset Driven Power Control:

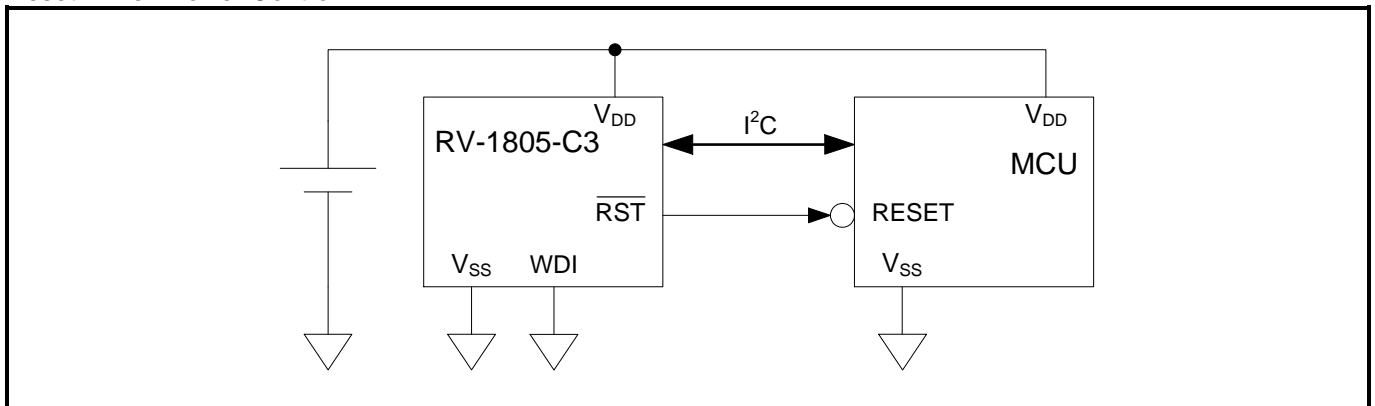

One potential issue with this approach is that many MCUs include internal pull-up resistors on their reset inputs, and the current drawn through that resistor when the reset input is held low is generally much higher than the MCU would draw in its inactive state. Any additional pull-up resistor should be removed and the \overline{RST} output of the RV-1805-C3 should be configured like a push-pull output.

4.18.4. INTERRUPT DRIVEN

The following Figure illustrates the simplest application, in which the RV-1805-C3 communicates with the system MCU using an interrupt. The MCU can go into standby mode, reducing power somewhat, until the RV-1805-C3 generates an interrupt based on an alarm or a timer function. This produces smaller power savings than other alternatives, but allows the MCU to wake in the shortest time.

Interrupt Driven Power Control:

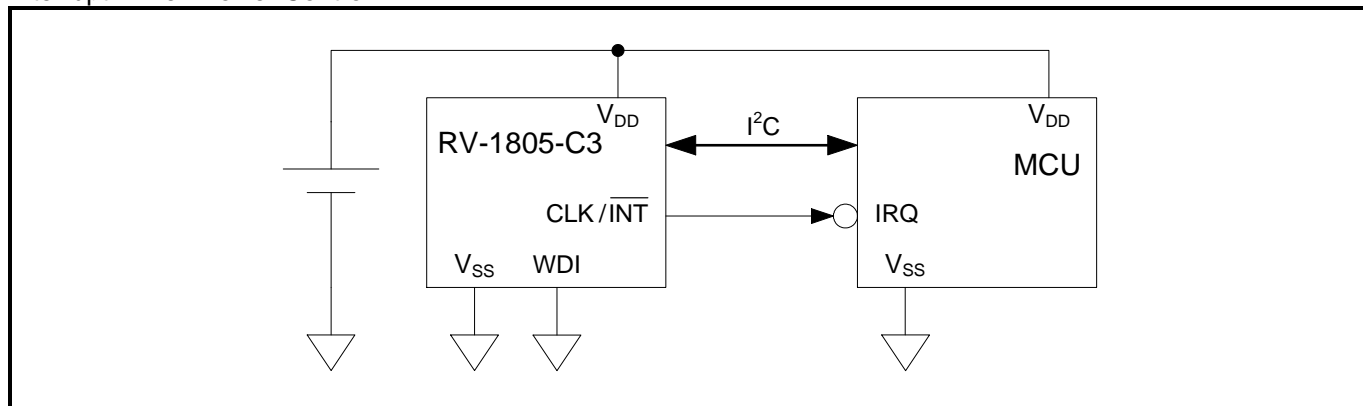

4.19. TYPICAL SYSTEM IMPLEMENTATION

The following Figure is a more detailed view of a typical system using the V_{SS} Power Switched approach. The V_{SS} pin of the MCU, and potentially other system components, is switched using the PSW pin of the RV-1805-C3. The CLK/INT pin of the RV-1805-C3 is connected to an interrupt input of the MCU, allowing the MCU to utilize the RTC interrupt functions of the RV-1805-C3 when it is awake. The RST output of the RV-1805-C3 is connected to the reset input of the MCU, enabling the RV-1805-C3 to control power on reset and integrate an external MCU reset button RESET. The MCU controls the RV-1805-C3 over the I²C channel.

System Example:

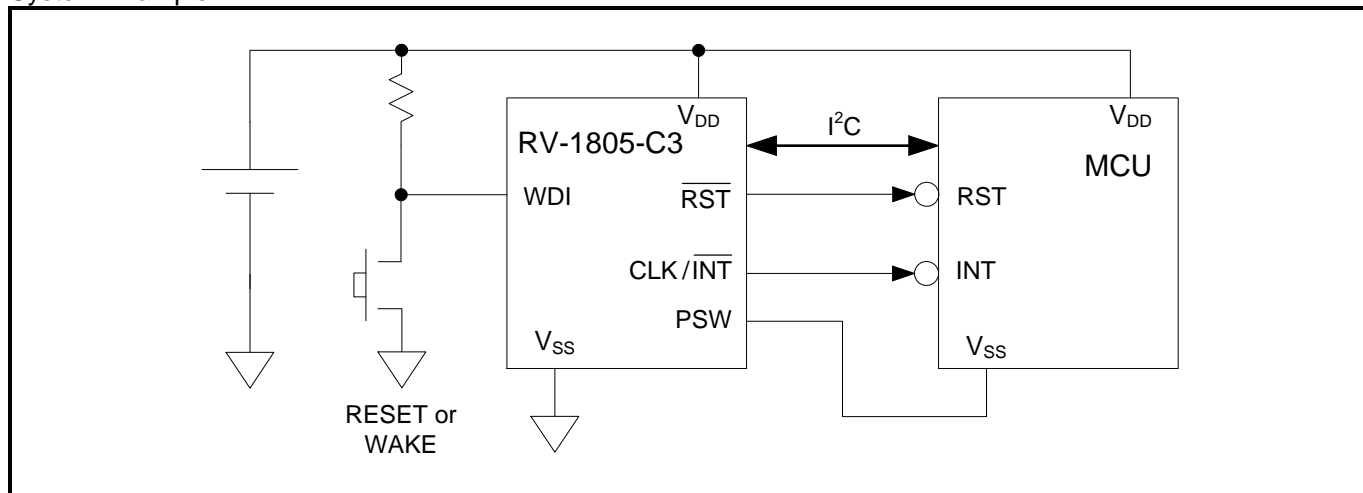

The key value of the RV-1805-C3 in this type of system is the ability to put the MCU into an off state, and providing a very rich variety of triggers which can cause the RV-1805-C3 to wake the MCU from the off state. There are a number of different triggers which may be useful.

4.19.1. ALARMS

The system may require the MCU to wake up at particular times, which is accomplished by configuring the Alarm Interrupt function of the RV-1805-C3.

4.19.2. COUNTDOWN TIMER

The system may require the MCU to wake up at periodic intervals which do not necessarily correspond to specific calendar times. The Countdown Timer of the RV-1805-C3 provides highly flexible time interval configuration to support this function.

4.19.3. WAKE BUTTON/SWITCH

A very common requirement is the capability to wake the system with a manual input such as a pushbutton or switch, typified by the WAKE button in the System Example above. The external interrupt input WDI may be simply connected to the button. The WDI input includes a Schmitt trigger circuitry to enable clean interrupts. If additional debouncing of the input is required, the RV-1805-C3 provides direct access to the interrupt input pin to facilitate software implementations.

4.19.4. EXTERNAL DEVICE INPUT

In some systems an external device such as a wakeup radio may provide a signal which must wake the MCU. The RV-1805-C3 external interrupt WDI pin provides this capability.

4.19.5. ANALOG INPUT

Some systems include analog signals, such as light sensors or detectors on radio antennas, which must wake the MCU. The Analog Comparator function, which allows the voltage on the V_{BACKUP} input of the RV-1805-C3 to be compared with a configurable voltage threshold and generate an interrupt, can easily be used in this application, and it allows flexible configuration, both in voltage levels and in transition direction to support different environments. The Analog Comparator may also be used to provide a second external digital interrupt if necessary by selecting the proper digital threshold.

4.19.6. BATTERY LOW DETECTION

The Analog Comparator can provide a battery low detection function. In this case the V_{DD} pin would be tied to the V_{BACKUP} pin, and the thresholds would be adjusted to insure that the Battery Low interrupt occurs prior to any Brownout Detection on the V_{DD} input. This allows software to prepare for a potential battery failure in advance without having to poll the battery level.

4.19.7. ERRORS

Any failure interrupt in the RV-1805-C3 may also be configured to wake the MCU. This can be particularly valuable for an XT Oscillator Failure detection, when software may need to respond to the error in order to report the problem quickly.

4.20. SAVING PARAMETERS

If the MCU is powered down in Sleep Mode, there is often some data which must be preserved until the next power up. The internal RAM of the RV-1805-C3 is always available, so software can easily save any necessary parameters prior to entering Sleep Mode and retrieve them when the MCU wakes up.

4.21. POWER SWITCH ELECTRICAL CHARACTERISTICS

The power switch on the RV-1805-C3 PSW pin has a typical on resistance of 1 Ω over the full temperature range so that currents up to 50 mA may be handled without appreciable voltage drop. This allows the RV-1805-C3 to switch power to multiple devices in most systems, which can be particularly important for components without internal Sleep functions. If the PSW pin is not used as a power switch, the maximum leakage current of the $\sim 1 \Omega$ switch is less than 250 pA at 25 $^{\circ}\text{C}$.

4.22. AVOIDING UNEXPECTED LEAKAGE PATHS

One potential problem which can occur when the RV-1805-C3 powers other devices down is that unexpected leakage paths can be created between the powered RV-1805-C3 and the unpowered device. The RV-1805-C3 can be configured to disable inputs and outputs in Sleep Mode to prevent leakage. In general, any input or output pin connected to a device which is powered down should be disabled. Any pins which remain powered in Sleep Mode, such as pushbutton inputs used to wake the system, must not be disabled.

See chapter 4.17.6 PIN CONTROL AND LEAKAGE MANAGEMENT (SLEEP CONTROL)

4.23. SYSTEM POWER ANALYSIS

The RV-1805-C3 can significantly improve the power characteristics of many different types of systems. A specific example will be presented, and several other generalizations can be made from this. The fundamental advantage provided by the RV-1805-C3 is that it allows the system designer to essentially ignore the sleep current of other system components, which allows the utilization of components which have been optimized for other parameters, such as active power, cost or functionality.

4.23.1. USING AN EXTERNAL RTC WITH POWER MANAGEMENT

The key element in any system power analysis is the usage profile, and for this example we assume the system is active for T_{act} and inactive for T_{inact} . I_{act} is the current drawn when the system is active, and I_{inact} is the current drawn when the system is inactive. The average current I_{avg} is therefore:

$$I_{\text{avg}} = (T_{\text{act}} * I_{\text{act}} + T_{\text{inact}} * I_{\text{inact}}) / (T_{\text{act}} + T_{\text{inact}})$$

An example will use a PIC16LF1947 MCU, which is highly optimized for low power operation. This MCU draws 80 nA in Sleep Mode, 1.8 μA in Sleep Mode with the internal oscillator and RTC active, and 120 μA in 500 KHz active mode. Assume a usage profile where the system is active for 1 second every 30 minutes, so that T_{act} is 1 and T_{inact} is 1799. If this MCU is used alone and supplies the RTC functions, the average current for the usage profile is:

$$I_{\text{avg}} = (1 * 120 \mu\text{A} + 1799 * 1.8 \mu\text{A}) / 1800 = \mathbf{1.865 \mu\text{A}} \quad // \text{ PIC alone}$$

If the RV-1805-C3 is used to provide the RTC functionality in RC Autocalibration Mode (<20 nA continuous current, when $T_A = 25^{\circ}\text{C}$, $V_{\text{DD}} = 3.0\text{V}$, $\text{ACP} = 1024$ seconds) and the PIC is placed into Sleep Mode, the average current for the usage profile is dramatically lower:

$$I_{\text{avg}} = (1 * 120 \mu\text{A} + 1799 * 80 \text{ nA}) / 1800 + 20 \text{ nA} = \mathbf{166 \text{ nA}} \quad // \text{ PIC in Sleep mode \& RV-1805-C3}$$

This is a significant improvement, but the current can be further reduced by having the RV-1805-C3 switch power to the MCU. The resulting average current is $\sim 50\%$ lower:

$$I_{\text{avg}} = (1 * 120 \mu\text{A} + 1799 * 0 \text{ nA}) / 1800 + 20 \text{ nA} = \mathbf{86 \text{ nA}} \quad // \text{ PIC switched \& RV-1805-C3}$$

4.23.2. MANAGING MCU ACTIVE POWER

In many cases, the duration of the active time is a function of how much processing must be accomplished, and can therefore be assumed to be a linear function of the MCU clock frequency in active mode. The examples in the previous section assumed that the MCU ran for 1 second at 500 KHz, so 500'000 cycles of an 8-bit processor were required. Like most MCUs, the PIC has a relatively constant active current as a function of clock frequency, so using a higher internal frequency in the same MCU would have little effect on the overall power. However, there may be other MCUs (such as those with 32-bit processors) which have better active power efficiency but poor sleep power, and power switching with the RV-1805-C3 eliminates any sleep power considerations.

4.23.3. LOWER COST MCUs

Lower cost MCUs often have poor sleep power characteristics relative to sleep optimized parts. Since the RV-1805-C3 eliminates sleep power considerations, these lower cost processors may provide equivalent overall average power at significant cost savings.

4.23.4. HIGH PERFORMANCE PROCESSORS

In some applications very high performance processors such as DSPs must be used due to real time processing requirements. These processors are generally not optimized for sleep performance, but they may be used in applications with low duty cycles. One example of this is fingerprint recognition, which is rarely accessed but must provide very fast response with complex processing. The RV-1805-C3 power management functions enable a system design where the processor is powered down the vast majority of the time, providing low average power combined with very high instantaneous performance.

4.24. TRICKLE CHARGER

The devices supporting the V_{BACKUP} pin include a trickle charging circuit which allows a battery or supercapacitor connected to the V_{BACKUP} pin to be charged from the power supply connected to the V_{DD} pin. The circuit of the Trickle Charger is shown in the following Figure. The Trickle Charger configuration is controlled by the 20h - Trickle Charge register (see ANALOG CONTROL REGISTERS). The Trickle Charger is enabled if a) the TCS field is 1010, b) the DIODE field is 01 or 10 and c) the ROUT field is not 00. A diode, with a typical voltage drop of 0.6V, is inserted in the charging path if DIODE is 10. A Schottky diode, with a typical voltage drop of 0.3V, is inserted in the charging path if DIODE is 01. The series current limiting resistor is selected by the ROUT field as shown in the figure.

Trickle Charger:

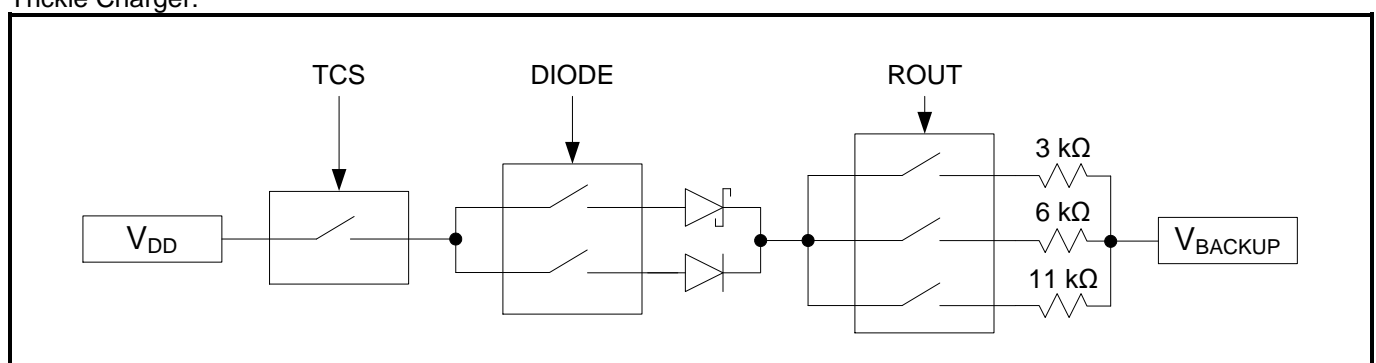

5. DIGITAL ARCHITECTURE SUMMARY

The following Figure illustrates the overall architecture of the pin inputs and outputs of the RV-1805-C3.

Digital Architecture Summary:

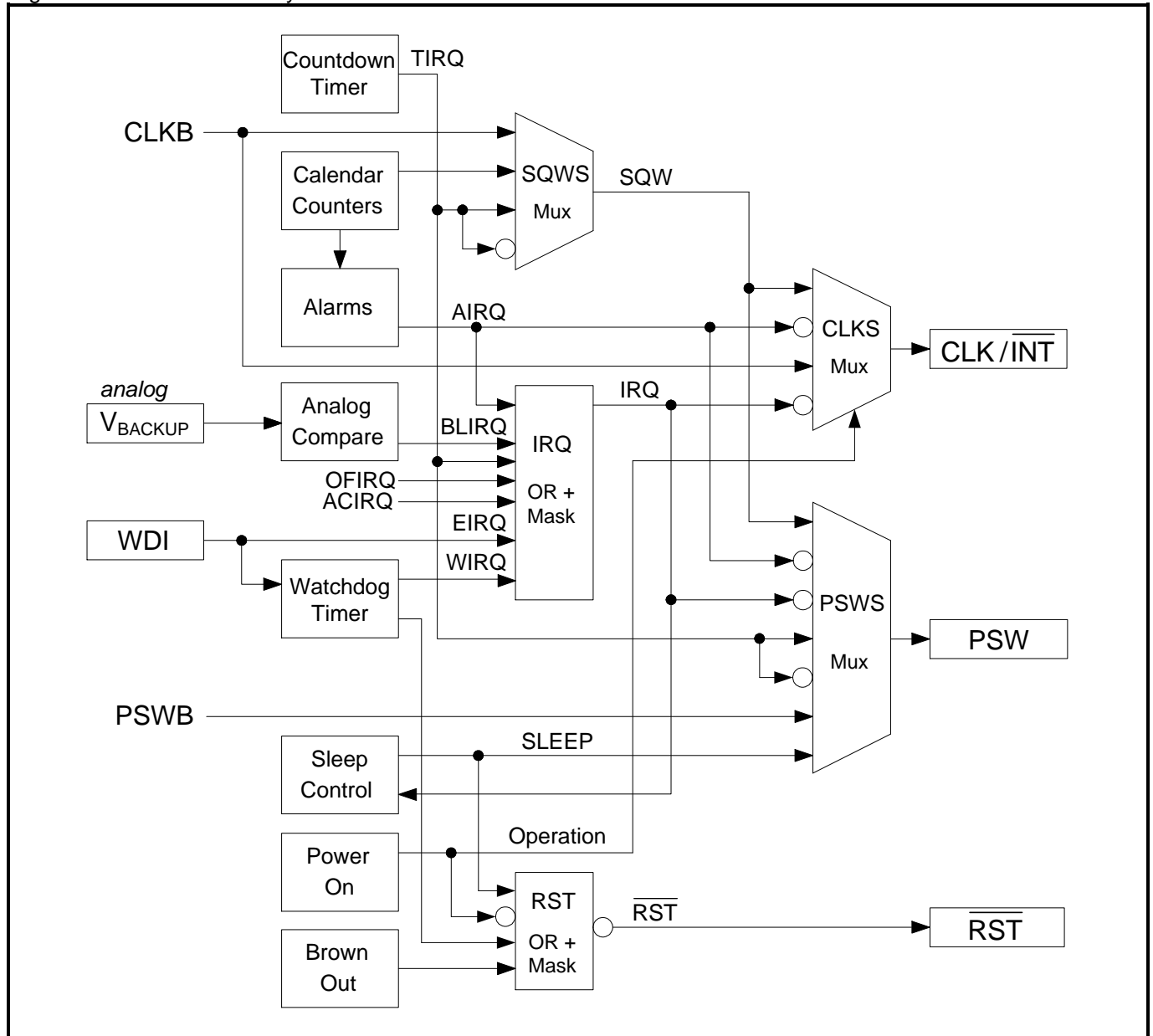

6. ELECTRICAL SPECIFICATIONS

6.1. ABSOLUTE MAXIMUM RATINGS

The following Table lists the absolute maximum ratings.

Absolute Maximum Ratings:

| SYMBOL | PARAMETER | TEST | MIN | TYP | MAX | UNIT |
|---------------------|-------------------------------|-------------------------------------|------|-----|---------------------------|------|
| V _{DD} | Power Supply Voltage | | -0.3 | | 3.8 | V |
| V _{BACKUP} | Backup Supply Voltage | | -0.3 | | 3.8 | V |
| V _I | Input voltage | VDD Power state | -0.3 | | V _{DD} + 0.3 | V |
| V _I | Input voltage | VBACKUP Power state | -0.3 | | V _{BACKUP} + 0.3 | V |
| V _O | Output voltage | VDD Power state | -0.3 | | V _{DD} + 0.3 | V |
| V _O | Output voltage | VBACKUP Power state | -0.3 | | V _{BACKUP} + 0.3 | V |
| I _I | Input current | | -10 | | 10 | mA |
| I _O | Output current | | -20 | | 20 | mA |
| I _{OPC} | PSW Output continuous current | | | | 50 | mA |
| I _{OPP} | PSW Output pulsed current | 1 second pulse | | | 150 | mA |
| V _{ESD} | ESD Voltage | CDM ⁽¹⁾ | | | ±500 | V |
| | | HBM ⁽²⁾ | | | ±4000 | V |
| I _{LU} | Latch-up Current | | | | 100 | mA |
| T _{STG} | Storage Temperature | | -55 | | 125 | °C |
| T _{OP} | Operating Temperature | | -40 | | 85 | °C |
| T _{SLD} | Lead temperature | Hand soldering for 10 seconds | | | 300 | °C |
| T _{REF} | Reflow soldering temperature | Reflow profile per JEDEC J-STD-020D | | | 260 | °C |

(1) CDM – Charged-Device Model
 (2) HBM – Human Body Model

6.2. POWER SUPPLY PARAMETERS

The following Figure and Table describe the power supply and switchover parameters. See POWER CONTROL AND SWITCHING for a detailed description of the operations.

Power Supply Switchover:

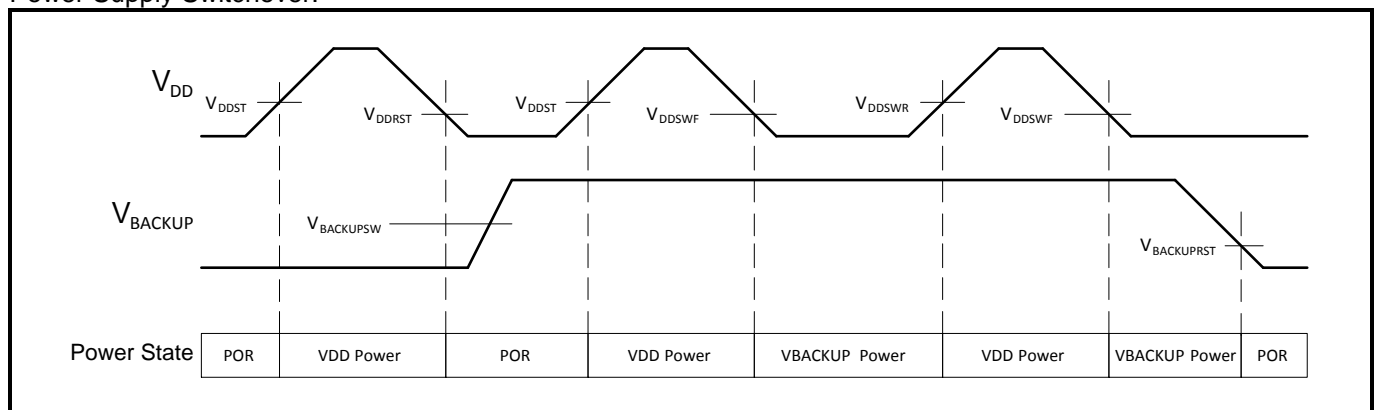

For all tables, $T_A = -40\text{ °C}$ to 85 °C , TYP values at 25 °C .

Power Supply and Switchover Parameters:

| SYMBOL | PARAMETER | PWR | TYPE | POWER STATE | TEST CONDITIONS | MIN | TYP | MAX | UNIT |
|---------------|--|--------------|---------|-----------------------------|--|-----|-----|-----|------------|
| V_{DD} | System Power Voltage | V_{DD} | Static | VDD Power | Clocks operating and RAM and registers retained | 1.5 | | 3.6 | V |
| V_{DDIO} | V_{DD} I ² C Interface Voltage | V_{DD} | Static | VDD Power | I ² C operation | 1.5 | | 3.6 | V |
| V_{DDST} | V_{DD} Start-up Voltage ⁽¹⁾ | V_{DD} | Rising | POR -> VDD Power | | 1.6 | | | V |
| V_{DDRST} | V_{DD} Reset Voltage | V_{DD} | Falling | VDD Power -> POR | $V_{BACKUP} < V_{BACKUP,MIN}$ or no V_{BACKUP} | | 1.3 | 1.5 | V |
| V_{DDSWR} | V_{DD} Rising Switch-over Threshold Voltage | V_{DD} | Rising | VBACKUP Power -> VDD Power | $V_{BACKUP} \geq V_{BACKRST}$ | | 1.6 | 1.7 | V |
| V_{DDSWF} | V_{DD} Falling Switch-over Threshold Voltage | V_{DD} | Falling | VDD Power -> VBACKUP Power | $V_{BACKUP} \geq V_{BACKSW,MIN}$ | 1.2 | 1.5 | | V |
| V_{DDSWH} | V_{DD} Switchover Threshold Hysteresis ⁽²⁾ | V_{DD} | Hyst. | VDD Power <-> VBACKUP Power | | | 70 | | mV |
| V_{DDFS} | V_{DD} Falling Slew Rate to switch to VBACKUP state ⁽⁴⁾ | V_{DD} | Falling | VDD Power -> VBACKUP Power | $V_{DD} < V_{DDSW,MAX}$ | 0.7 | 1.4 | | V/ms |
| V_{BACKUP} | Backup Voltage | V_{BACKUP} | Static | VBACKUP Power | Clocks operating and RAM and registers retained | 1.4 | | 3.6 | V |
| V_{BACKSW} | Backup Switchover Voltage Range ⁽⁵⁾ | V_{BACKUP} | Static | VDD Power -> VBACKUP Power | | 1.6 | | 3.6 | V |
| $V_{BACKRST}$ | Falling Backup POR Voltage ⁽⁷⁾ | V_{BACKUP} | Falling | VBACKUP Power -> POR | $V_{DD} < V_{DDSWF}$ | | 1.1 | 1.4 | V |
| V_{BMRG} | V_{BACKUP} Margin above V_{DD} ⁽³⁾ | V_{BACKUP} | Static | VBACKUP Power | | 200 | | | mV |
| $V_{BACKESR}$ | V_{BACKUP} supply series resistance ⁽⁶⁾ | V_{BACKUP} | Static | VBACKUP Power | | 1.0 | 1.5 | | k Ω |

(1) V_{DD} must be above V_{DDST} to exit the POR state, independent of the V_{BACKUP} voltage.
(2) Difference between V_{DDSWR} and V_{DDSWF} .
(3) V_{BACKUP} must be higher than V_{DD} by at least this voltage to insure the RV-1805-C3 remains in the VBACKUP Power state.
(4) Maximum V_{DD} falling slew rate to guarantee correct switchover to VBACKUP Power state. There is no V_{DD} falling slew rate requirement if switching to the VBACKUP power source is not required.
(5) V_{BACKUP} voltage to guarantee correct transition to VBACKUP Power state when V_{DD} falls.
(6) Total series resistance of the power source attached to the V_{BACKUP} pin. The optimal value is 1.5 k Ω , which may require an external resistor. V_{BACKUP} power source ESR (Equivalent Series Resistance) + external resistor value = 1.5 k Ω .
(7) $V_{BACKRST}$ is also the static voltage required on V_{BACKUP} for register data retention.

6.3. OPERATING PARAMETERS

The following Table lists the operating parameters. For this table, $T_A = -40\text{ }^{\circ}\text{C}$ to $85\text{ }^{\circ}\text{C}$, TYP values at $25\text{ }^{\circ}\text{C}$.

Operating Parameters:

| SYMBOL | PARAMETER | TEST CONDITIONS | V_{DD} | MIN | TYP | MAX | UNIT |
|-------------|--|-----------------|-------------|-----|------|------|----------|
| V_{T+} | Positive-going Input Threshold Voltage | | 3.0V | | 1.5 | 2.0 | V |
| | | | 1.8V | | 1.1 | 1.25 | |
| V_{T-} | Negative-going Input Threshold Voltage | | 3.0V | 0.8 | 0.9 | | V |
| | | | 1.8V | 0.5 | 0.6 | | |
| I_{LEAK} | Input leakage current | | 3.0V | | 0.02 | 80 | nA |
| C_I | Input capacitance | | | | 3 | | pF |
| R_{DSON} | PSW output resistance to V_{DD} | PSW Enabled | 1.7V | | 1.7 | 5.8 | Ω |
| | | | 1.8V | | 1.6 | 5.4 | |
| | | | 3.0V | | 1.1 | 3.8 | |
| | | | 3.6V | | 1.05 | 3.7 | |
| I_{OLEAK} | Output leakage current | | 1.7V – 3.6V | | 0.02 | 80 | nA |

6.4. OSCILLATOR PARAMETERS

The following Table lists the oscillator parameters. For this Table, $T_A = -40\text{ }^{\circ}\text{C}$ to $85\text{ }^{\circ}\text{C}$ unless otherwise indicated. $V_{DD} = 1.7$ to 3.6V , TYP values at $25\text{ }^{\circ}\text{C}$ and 3.0V . See also XT FREQUENCY CHARACTERISTICS.

Oscillator Parameters:

| SYMBOL | PARAMETER | TEST CONDITIONS | MIN | TYP | MAX | UNIT |
|---|---|---|-----|--------|-----|--------------------|
| F_{XT} | Crystal Frequency | | | 32.768 | | kHz |
| F_{OF} | XT Oscillator failure detection frequency | | | 8 | | kHz |
| F_{RCC} | Calibrated RC Oscillator Frequency ⁽¹⁾ | Factory Calibrated at $25\text{ }^{\circ}\text{C}$, $V_{DD} = 2.8\text{V}$ | | 64 | | Hz |
| F_{RCU} | Uncalibrated RC Oscillator Frequency | Calibration Disabled (OFFSETR = 0) – 128 Hz level | 89 | 122 | 220 | Hz |
| J_{RCCC} | Uncalibrated RC Oscillator cycle-to-cycle jitter, Median | Calibration Disabled (OFFSETR = 0) – 128 Hz level | | 2000 | | ppm |
| | | Calibration Disabled (OFFSETR = 0) – 1 Hz level | | 500 | | |
| | RC Oscillator cycle-to-cycle jitter, MIN, MAX | 128 Hz level at $25\text{ }^{\circ}\text{C}$ | 1 | | 1 | % |
| | | 128 Hz level, $-10\text{ }^{\circ}\text{C}$ to $70\text{ }^{\circ}\text{C}$ | 3.5 | | 3.5 | |
| 128 Hz level, $-40\text{ }^{\circ}\text{C}$ to $85\text{ }^{\circ}\text{C}$ | | 10 | | 10 | | |
| A_{XT} | XT mode digital calibration accuracy ⁽¹⁾ | Calibrated at an initial temperature and voltage. Factory Calibrated at $25\text{ }^{\circ}\text{C}$, $V_{DD} = 3.0\text{V}$ | -2 | | +2 | ppm |
| A_{AC} | Autocalibration mode timing accuracy, 512 second period, $T_A = -10\text{ }^{\circ}\text{C}$ to $60\text{ }^{\circ}\text{C}$ ⁽¹⁾ | 24 hour run time | | 35 | | ppm |
| | | 1 week run time | | 20 | | |
| | | 1 month run time | | 10 | | |
| | | 1 year run time | | 3 | | |
| T_{AC} | Autocalibration mode operating temperature ⁽²⁾ | | -10 | | 60 | $^{\circ}\text{C}$ |

⁽¹⁾ Timing accuracy is specified at $25\text{ }^{\circ}\text{C}$ after digital calibration of the internal RC oscillator and digital calibration of the 32.768 kHz crystal. The 32.768 kHz tuning fork crystal has a negative temperature coefficient with a parabolic frequency deviation, which can result in a change of up to 150 ppm across the entire operating temperature range of $-40\text{ }^{\circ}\text{C}$ to $85\text{ }^{\circ}\text{C}$ in XT mode. Autocalibration mode timing accuracy is specified relative to XT mode timing accuracy from $-10\text{ }^{\circ}\text{C}$ to $60\text{ }^{\circ}\text{C}$.

⁽²⁾ Outside of this temperature range, the RC oscillator frequency change due to temperature may be outside of the allowable RC digital calibration range ($\pm 12\%$) for autocalibration mode. When this happens, an autocalibration failure will occur and the ACF interrupt flag is set. The RV-1805-C3 should be switched to use the XT oscillator as its clock source when this occurs. Please see the AUTOCALIBRATION FAILURE section for more details.

The following Figure shows the typical calibrated RC oscillator frequency variation vs. temperature. The RC oscillator is factory calibrated at 2.8V, 25°C (OFFSETR = Preconfigured reset value).

Factory Calibrated RC Oscillator, Typical Frequency Variation vs. Temperature (64 Hz level is modified):

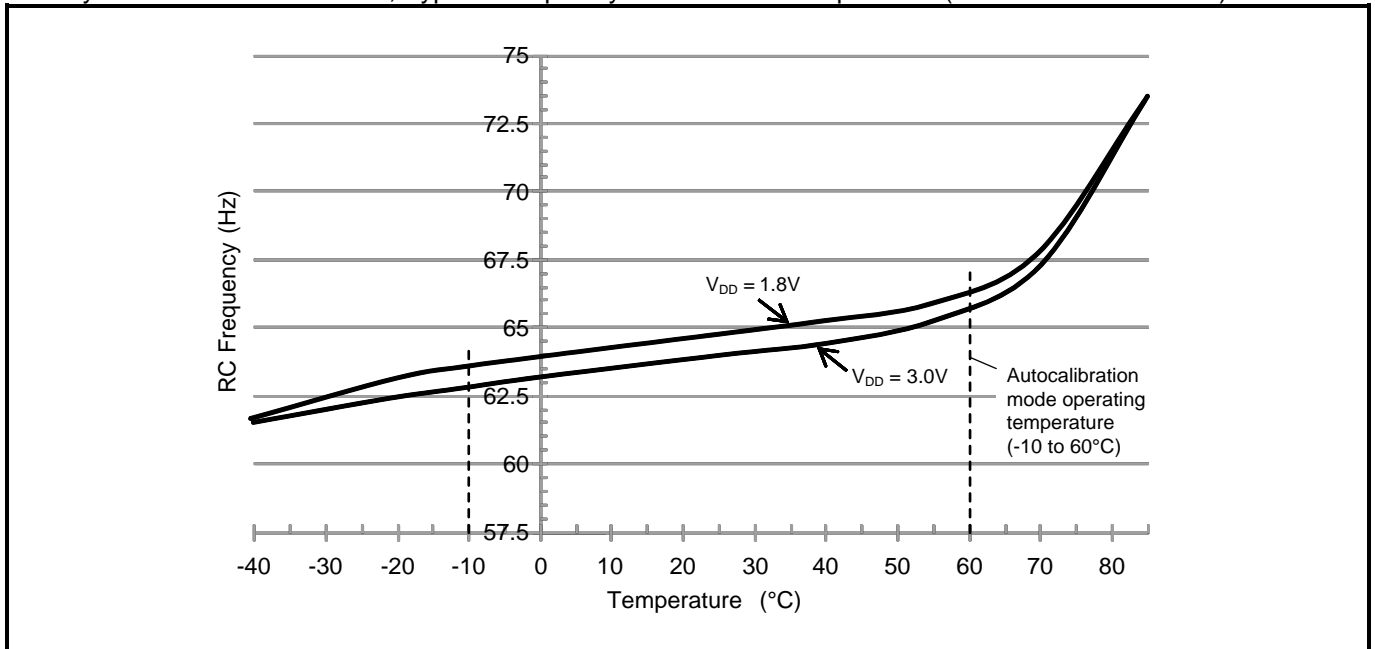

The following Figure shows the typical uncalibrated RC oscillator frequency variation vs. temperature.

Uncalibrated RC Oscillator at 64 Hz level, Typical Frequency Variation vs. Temperature:

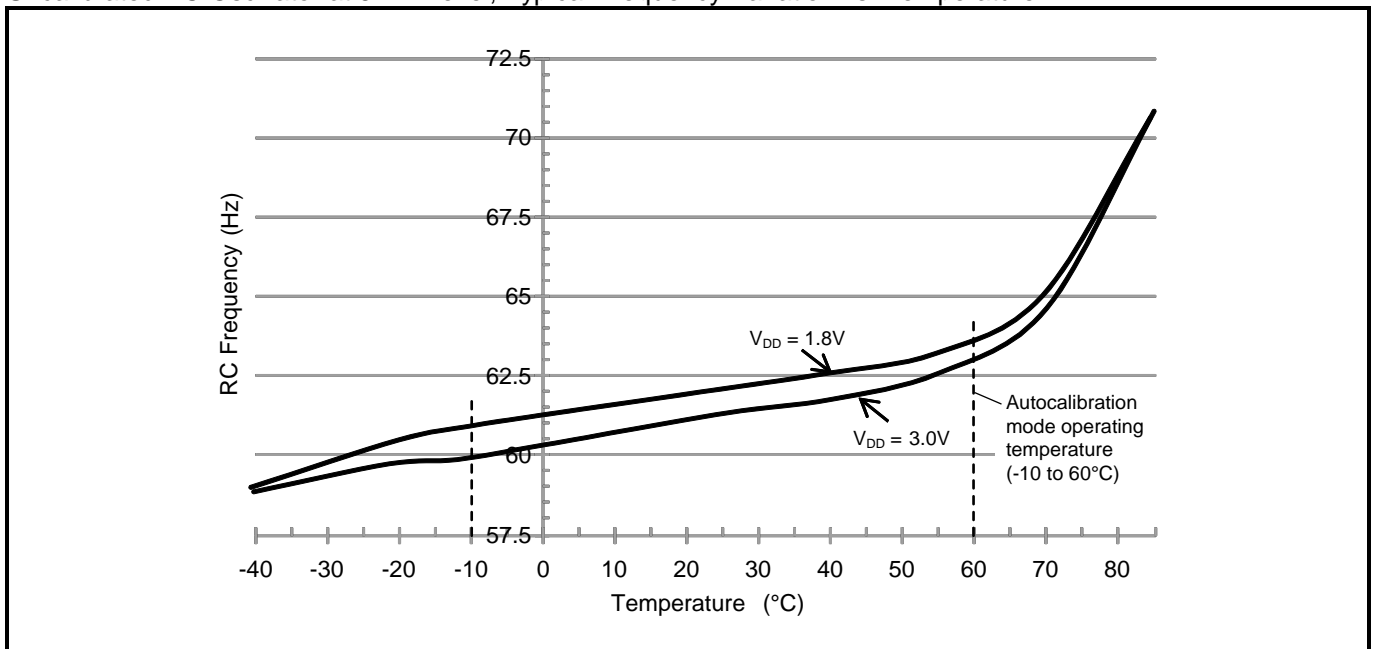

6.5. XT FREQUENCY CHARACTERISTICS

For this Table, $T_A = -40\text{ }^\circ\text{C}$ to $85\text{ }^\circ\text{C}$ unless otherwise indicated. $V_{DD} = 1.7$ to 3.6V , TYP values at $25\text{ }^\circ\text{C}$ and 3.0V , $f_{OSC} = 32.768\text{ kHz}$.

XT Frequency Characteristics:

| SYMBOL | PARAMETER | CONDITIONS | MIN | TYP | MAX | UNIT |
|-------------------|---|--|---|-----|-----|------------------|
| $\Delta F/F$ | Frequency accuracy | $T_A = +25^\circ\text{C}$, Calibration Disabled (OFFSETX = 0) | ± 100 ⁽¹⁾ | | | ppm |
| $\Delta F/F_0$ | Frequency vs. temperature characteristics | $T_{OPR} = -40^\circ\text{C}$ to $+85^\circ\text{C}$ | $-0.035^{\text{ppm}/^\circ\text{C}^2} (T_{OPR} - T_0)^2 \pm 10\%$ | | | ppm |
| T_0 | Turnover temperature | | $+25 \pm 5$ | | | $^\circ\text{C}$ |
| $\Delta F/F$ | Aging first year max. | $T_A = +25^\circ\text{C}$ | ± 3 | | | ppm |
| V_{START} | Oscillator start-up voltage | $T_A = -40\text{ }^\circ\text{C}$ to $85\text{ }^\circ\text{C}$ | 1.6 | | | V |
| T_{START} | Oscillator start-up time | $V_{DD} = 1.7\text{V} - 3.6\text{V}$ | | 1.0 | | s |
| δ_{CLKOUT} | CLKOUT duty cycle | $f_{CLKOUT} = 32.768\text{ kHz}$ $T_A = +25^\circ\text{C}$ | 60 ± 10 | | | % |

⁽¹⁾ The XT mode digital calibration accuracy is +/-2 ppm, see OSCILLATOR PARAMETERS.

6.5.1. XT FREQUENCY VS. TEMPERATURE CHARACTERISTICS

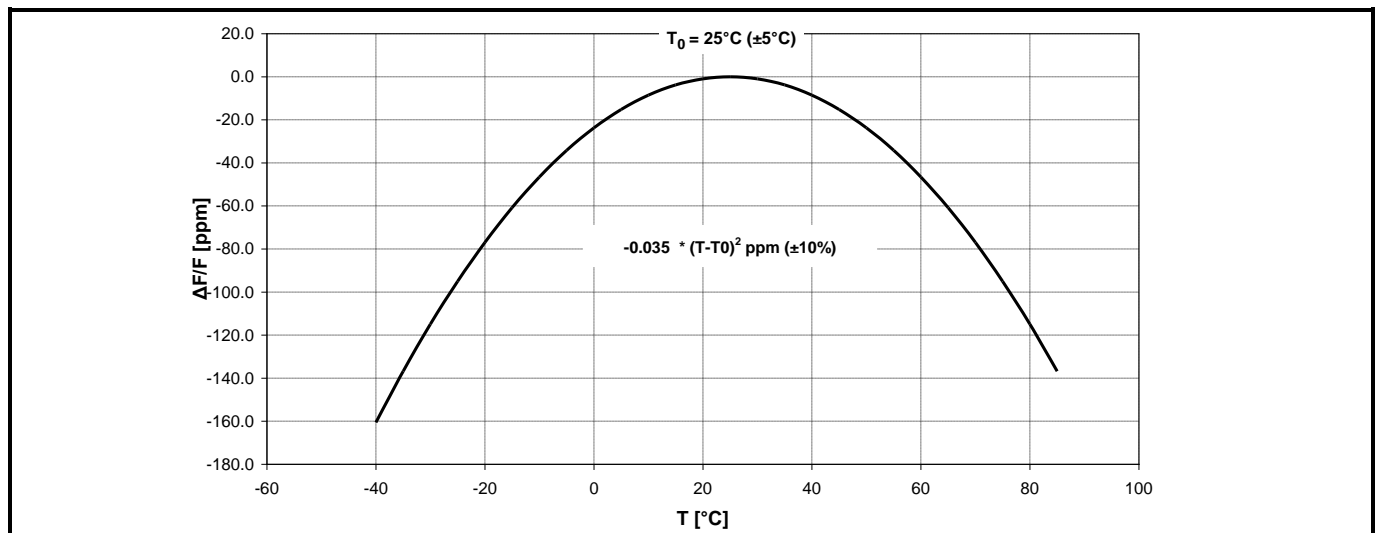

6.6. V_{DD} SUPPLY CURRENT

The following Table lists the current supplied into the V_{DD} power input under various conditions. For this table, T_A = -40 °C to 85 °C, V_{BACKUP} = 0 V to 3.6 V, TYP values at 25 °C, VDD Power state.

V_{DD} Supply Current:

| SYMBOL | PARAMETER | TEST CONDITIONS | V _{DD} | MIN | TYP | MAX | UNIT |
|-----------------------|--|---|-----------------|-----|------|-----|------|
| I _{VDD:I2C} | V _{DD} supply current during I ² C burst read/write | 400kHz bus speed, 2.2k pull-up resistors on SCL/SDA ⁽¹⁾ | 3.0V | | 6 | 10 | μA |
| | | | 1.8V | | 1.5 | 3 | |
| I _{VDD:XT} | V _{DD} supply current in XT oscillator mode. | Time keeping mode with XT oscillator running ⁽²⁾ | 3.0V | | 60 | 330 | nA |
| | | | 1.8V | | 57 | 290 | |
| I _{VDD:RC} | V _{DD} supply current in RC oscillator mode. | Time keeping mode with only the RC oscillator running (XT oscillator is off) ⁽²⁾ | 3.0V | | 17 | 220 | nA |
| | | | 1.8V | | 14 | 170 | |
| I _{VDD:ACAL} | Average V _{DD} supply current in Autocalibrated RC oscillator mode. | Time keeping mode with only RC oscillator running and Autocalibration enabled. ACP = 512 seconds ⁽²⁾ | 3.0V | | 22 | 235 | nA |
| | | | 1.8V | | 18 | 190 | |
| I _{VDD:CK32} | Additional V _{DD} supply current with CLK / INT at 32.768 kHz. | Time keeping mode with XT oscillator running, 32.768 kHz square wave on CLK / INT ⁽³⁾ | 3.0V | | 0.71 | | μA |
| | | | 1.8V | | 0.34 | | |
| I _{VDD:CK64} | Additional V _{DD} supply current with CLK / INT at 64 Hz. | All time keeping modes, 64 Hz square wave on CLK / INT ⁽³⁾ | 3.0V | | 0.6 | | nA |
| | | | 1.8V | | 0.3 | | |

- (1) Excluding external peripherals and pull-up resistor current. All other inputs (besides SDA and SCL) are at 0V or V_{DD}. Test conditions: Continuous burst read/write, 55h data pattern, 25 μs between each data byte, 20 pF load on each bus pin.
- (2) All inputs and outputs are at 0V or V_{DD}.
- (3) All inputs and outputs except CLK / INT are at 0V or V_{DD}. 15 pF load on CLK / INT, pull-up resistor current not included.

The following Figure shows the typical VDD power state operating current vs. temperature in XT mode.

Typical V_{DD} Current vs. Temperature in XT Mode:

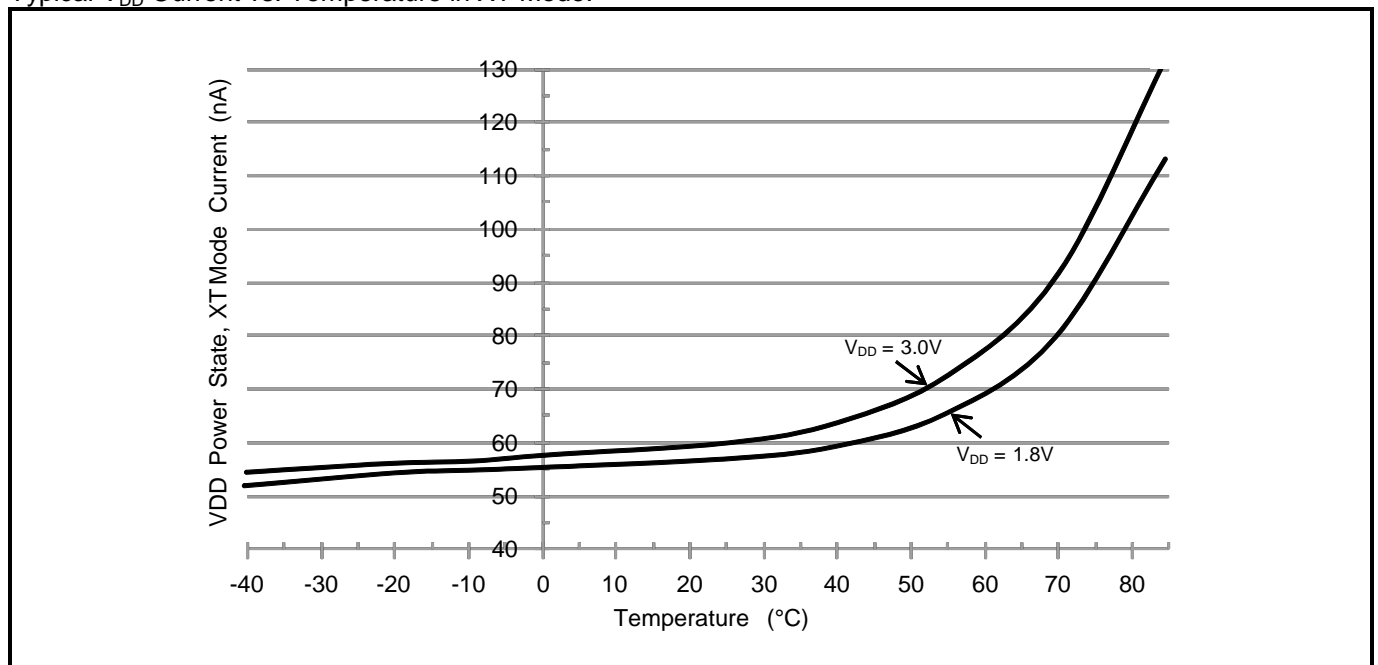

The following Figure shows the typical VDD power state operating current vs. temperature in RC mode.

Typical V_{DD} Current vs. Temperature in RC Mode:

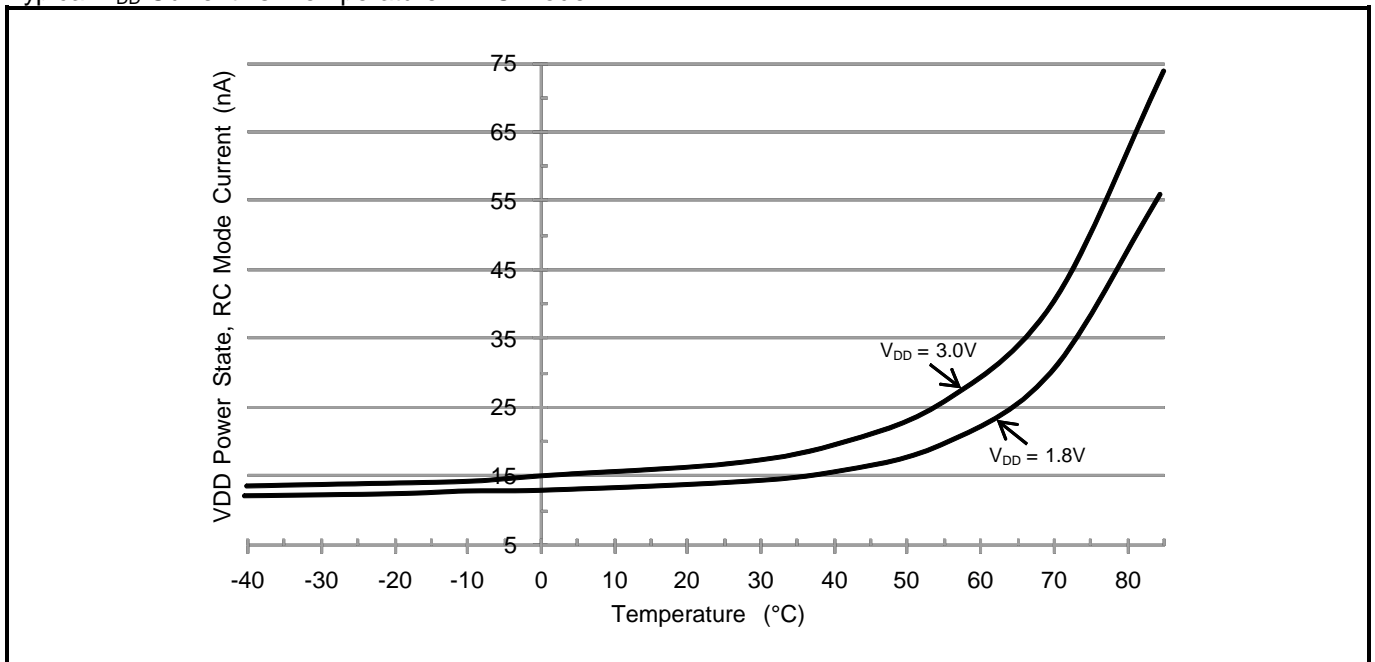

The following Figure shows the typical VDD power state operating current vs. temperature in RC Autocalibration mode.

Typical V_{DD} Current vs. Temperature in RC Autocalibration Mode, ACP = 512 seconds:

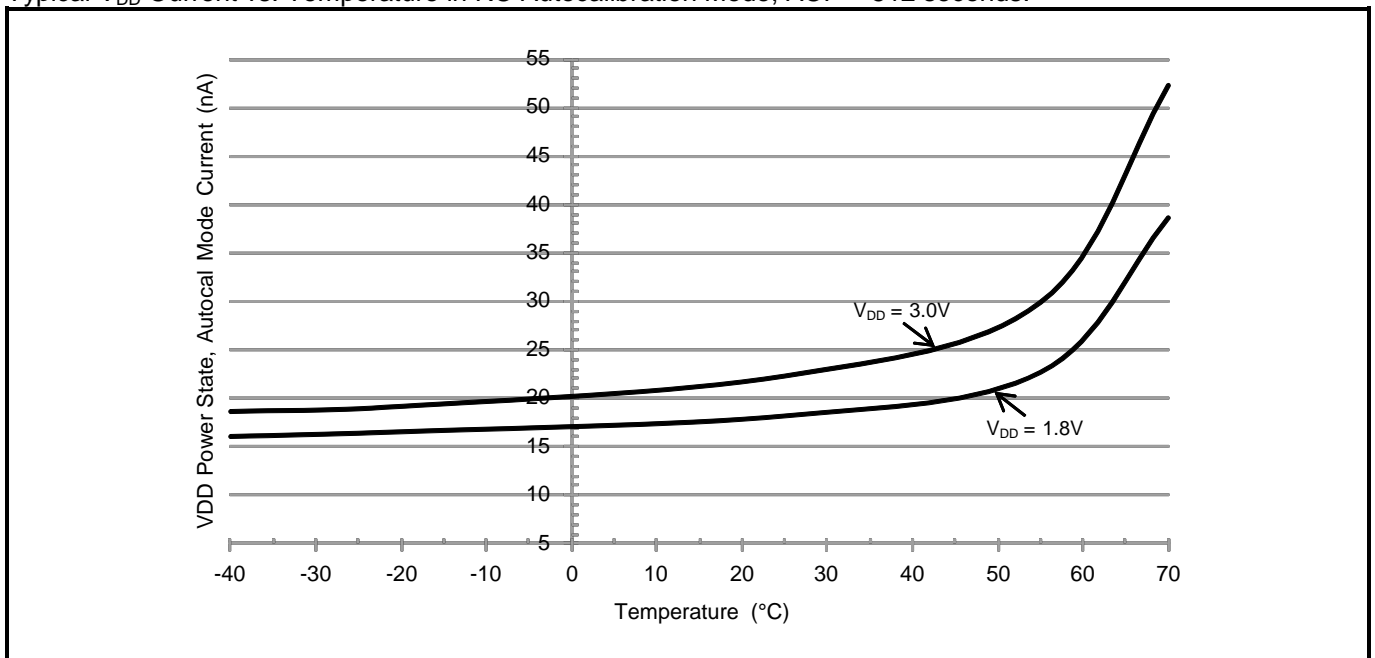

The following Figure shows the typical VDD power state operating current vs. voltage for XT Oscillator and RC Oscillator modes and the average current in RC Autocalibrated mode with ACP = 512 seconds.

Typical V_{DD} Current vs. Voltage, Different Modes of Operation:

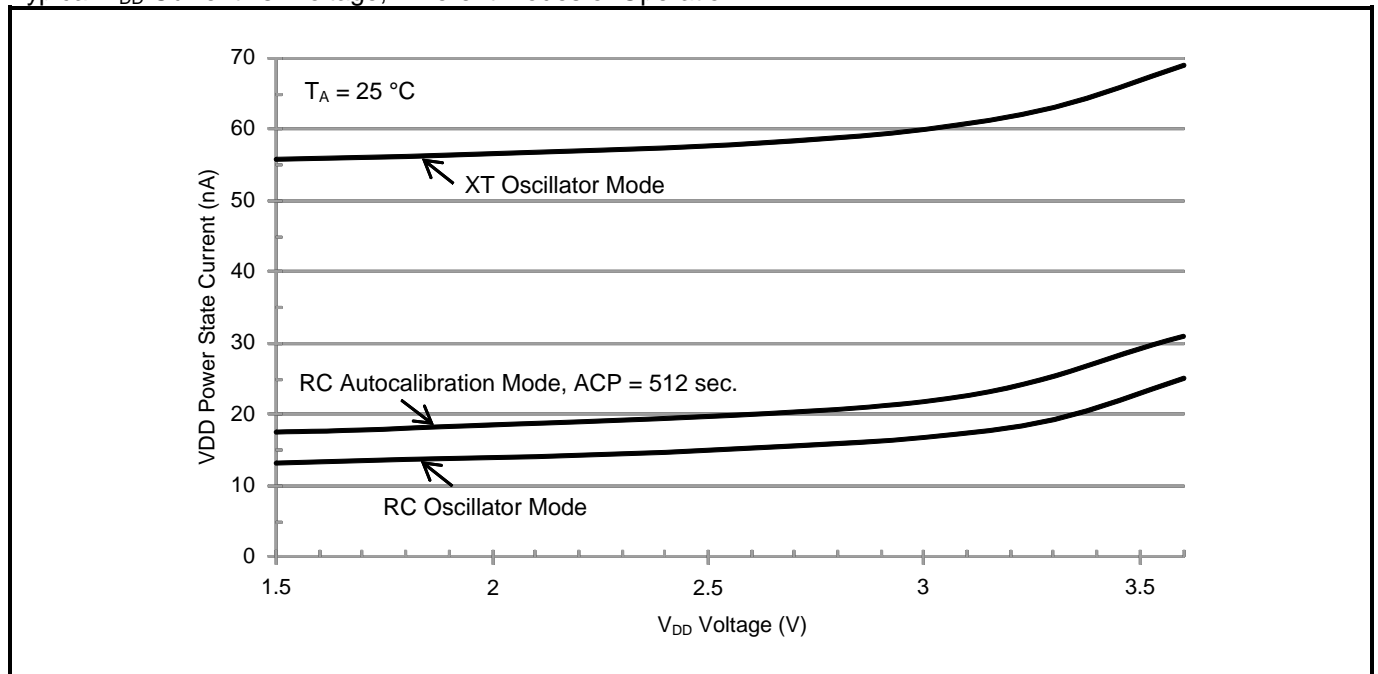

The following Figure shows the typical VDD power state operating current during continuous I²C burst read and write activity. Test conditions: T_A = 25 °C, 55h data pattern, 25 μs between each data byte, 20 pF load on each bus pin, pull-up resistor current not included.

Typical V_{DD} Current vs. Voltage, I²C Burst Read/Write:

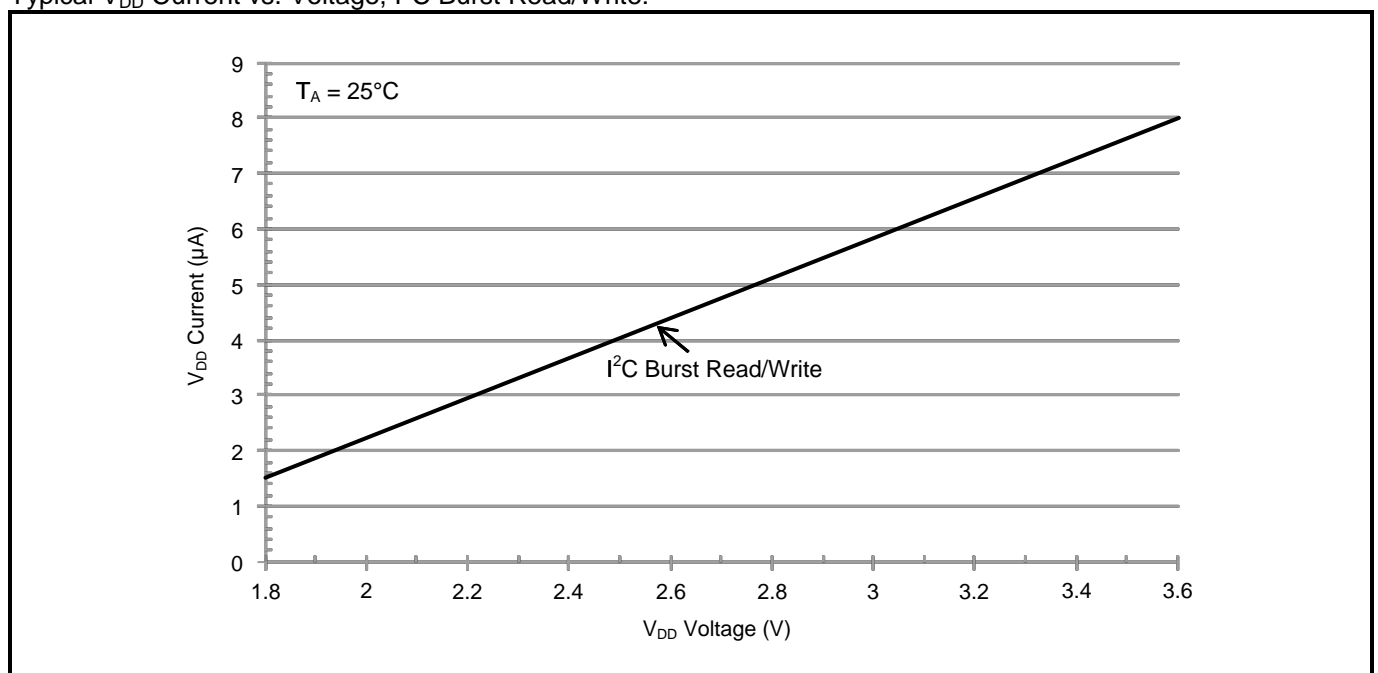

The following Figure shows the typical additional V_{DD} power state operating current with a 32.768 kHz clock output on the CLK/ $\overline{\text{INT}}$ pin. Test conditions: T_A = 25 °C. All inputs and outputs except CLK/ $\overline{\text{INT}}$ are at 0 V or V_{DD}. 15 pF capacitive load on the CLK/ $\overline{\text{INT}}$ pin, pull-up resistor current not included.

Typical additional V_{DD} Current vs. Voltage, 32.768 kHz Clock Output:

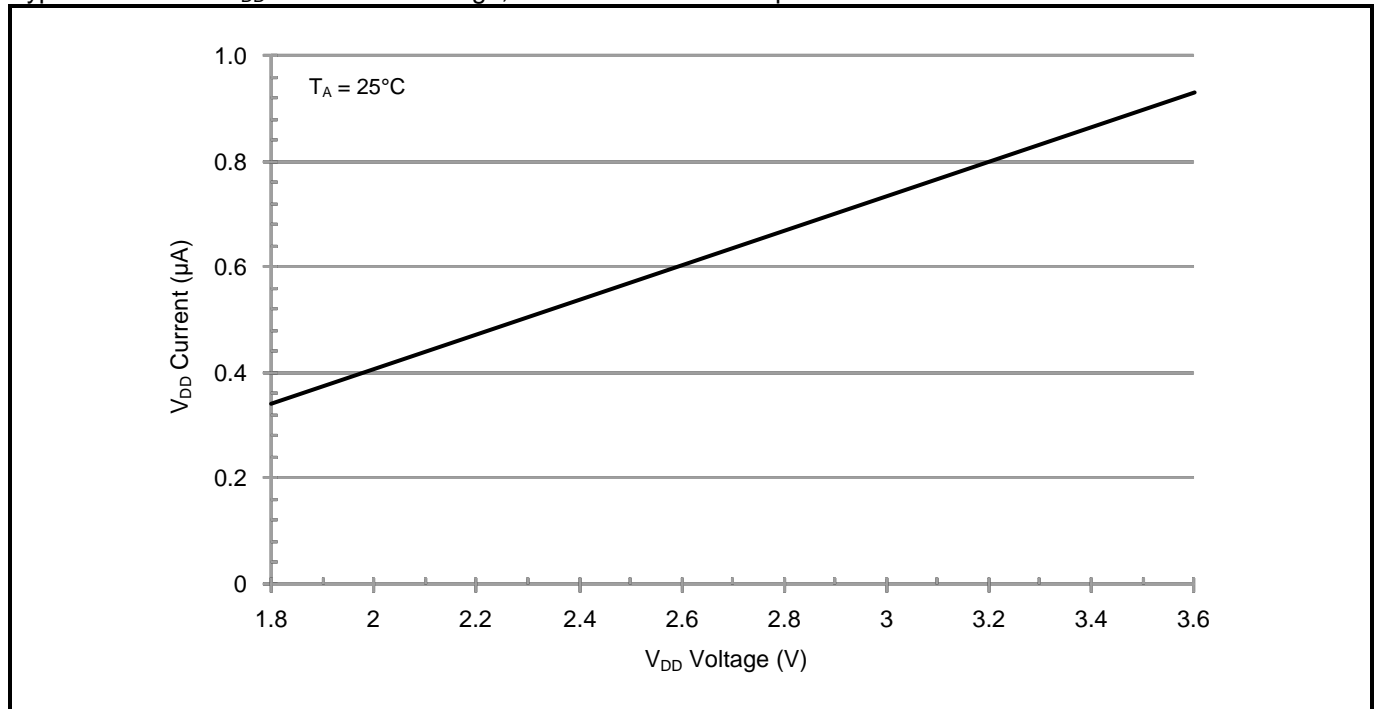

6.7. V_{BACKUP} SUPPLY CURRENT

The following Table lists the current supplied into the V_{BACKUP} power input under various conditions. For this table, T_A = -40 °C to 85 °C, TYP values at 25 °C, MAX values at 85 °C, V_{BACKUP} Power state.

V_{BACKUP} Supply Current:

| SYMBOL | PARAMETER | TEST CONDITIONS | V _{DD} | V _{BACK} | MIN | TYP | MAX | UNIT |
|-------------------------|--|--|----------------------|-------------------|-----|-----|-----|------|
| I _{VBACK:XT} | V _{BACKUP} supply current in XT oscillator mode. | Time keeping mode with XT oscillator running ⁽¹⁾ | < V _{DDSWF} | 3.0V | | 63 | 330 | nA |
| | | | | 1.8V | | 60 | 290 | |
| I _{VBACK:RC} | V _{BACKUP} supply current in RC oscillator mode. | Time keeping mode with only the RC oscillator running (XT oscillator is off) ⁽¹⁾ | < V _{DDSWF} | 3.0V | | 19 | 220 | nA |
| | | | | 1.8V | | 16 | 170 | |
| I _{VBACK:ACAL} | V _{BACKUP} supply current in Autocalibrated RC oscillator mode. | Time keeping mode with the RC oscillator running and Autocalibration enabled. ACP = 512 seconds ⁽¹⁾ | < V _{DDSWF} | 3.0V | | 25 | 235 | nA |
| | | | | 1.8V | | 21 | 190 | |
| I _{VBACK:VDD} | V _{BACKUP} supply current in V _{DD} powered mode. | V _{DD} powered mode ⁽¹⁾ | 1.7-3.6 V | 3.0V | -5 | 0.6 | 20 | nA |
| | | | | 1.8V | -10 | 0.5 | 16 | |

⁽¹⁾ Test conditions: All inputs and outputs are at 0V or V_{DD}.

The following Figure shows the typical V_{BACKUP} power state operating current vs. temperature in XT mode.

Typical V_{BACKUP} Current vs. Temperature in XT Mode:

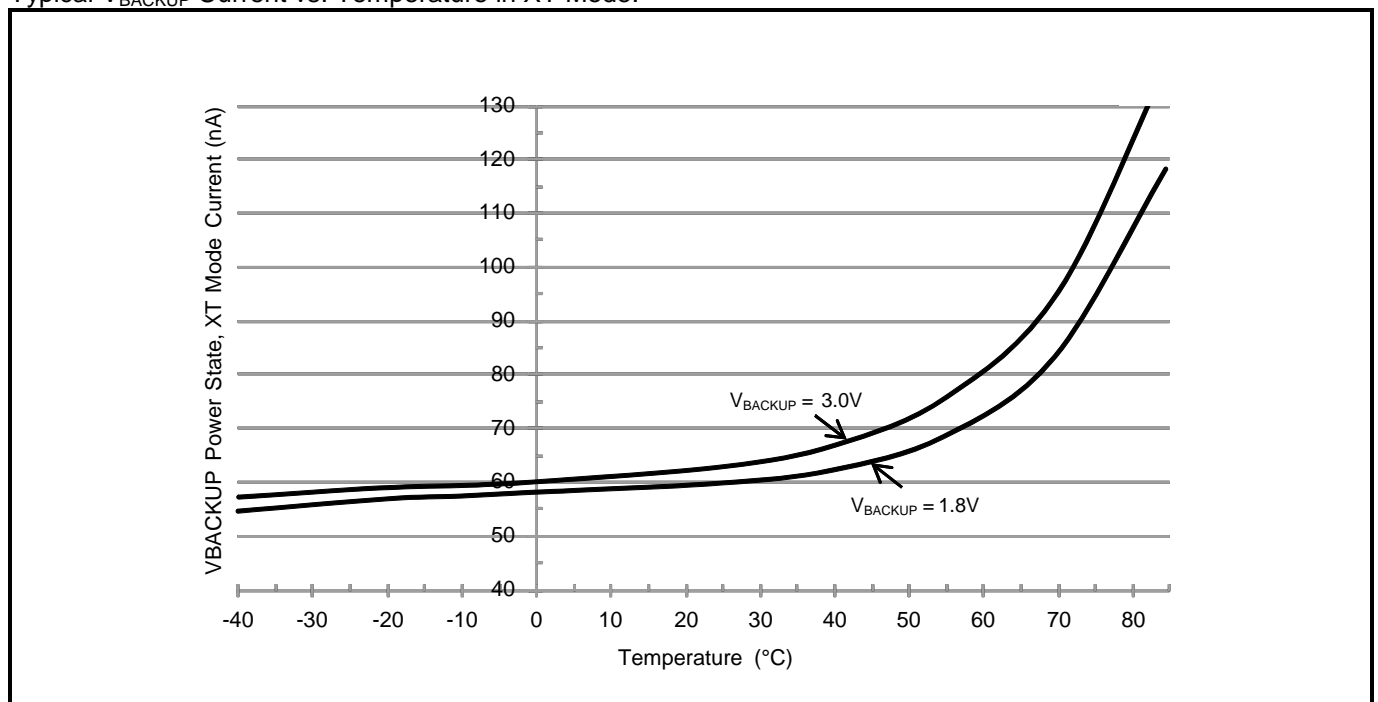

The following Figure shows the typical VBACKUP power state operating current vs. temperature in RC mode.

Typical V_{BACKUP} Current vs. Temperature in RC Mode:

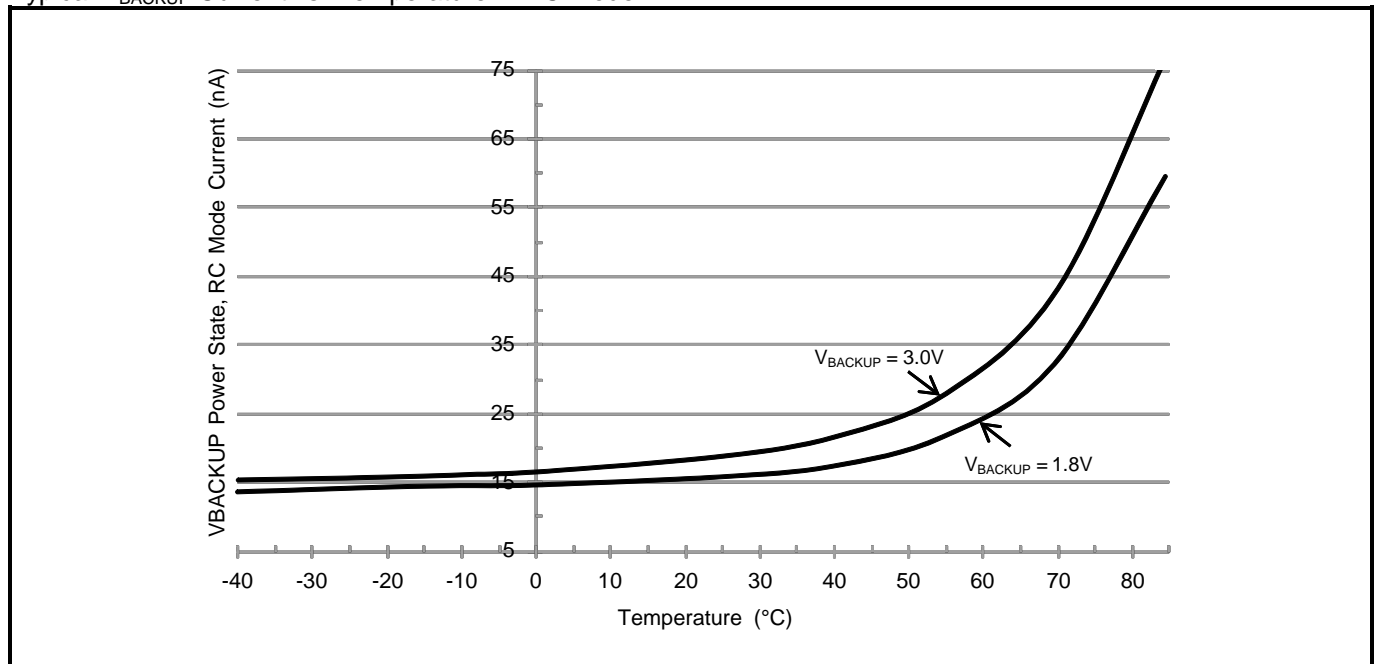

The following Figure shows the typical VBACKUP power state operating current vs. temperature in RC Autocalibration mode.

Typical V_{BACKUP} Current vs. Temperature in RC Autocalibration Mode, ACP = 512 seconds:

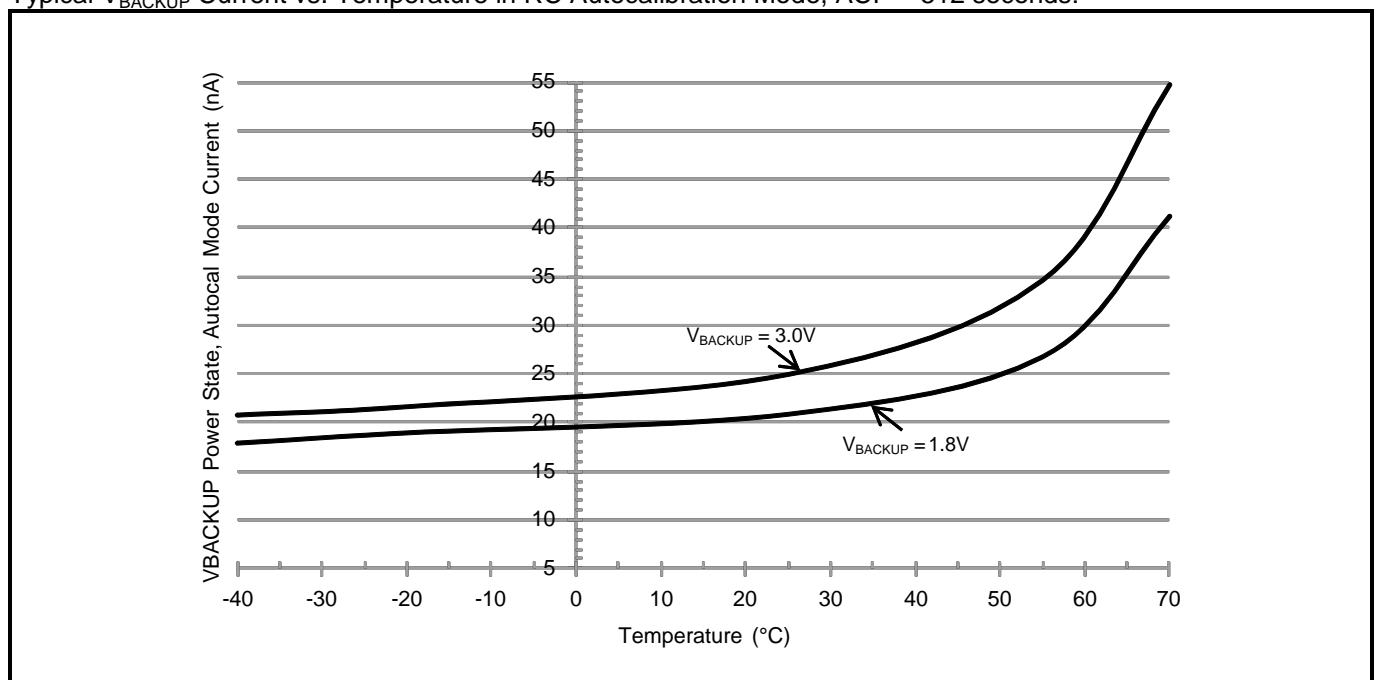

The following Figure shows the typical VBACKUP power state operating current vs. voltage for XT Oscillator and RC Oscillator modes and the average current in RC Autocalibrated mode with ACP = 512 seconds, V_{DD} = 0 V.

Typical V_{BACKUP} Current vs. Voltage, Different Modes of Operation:

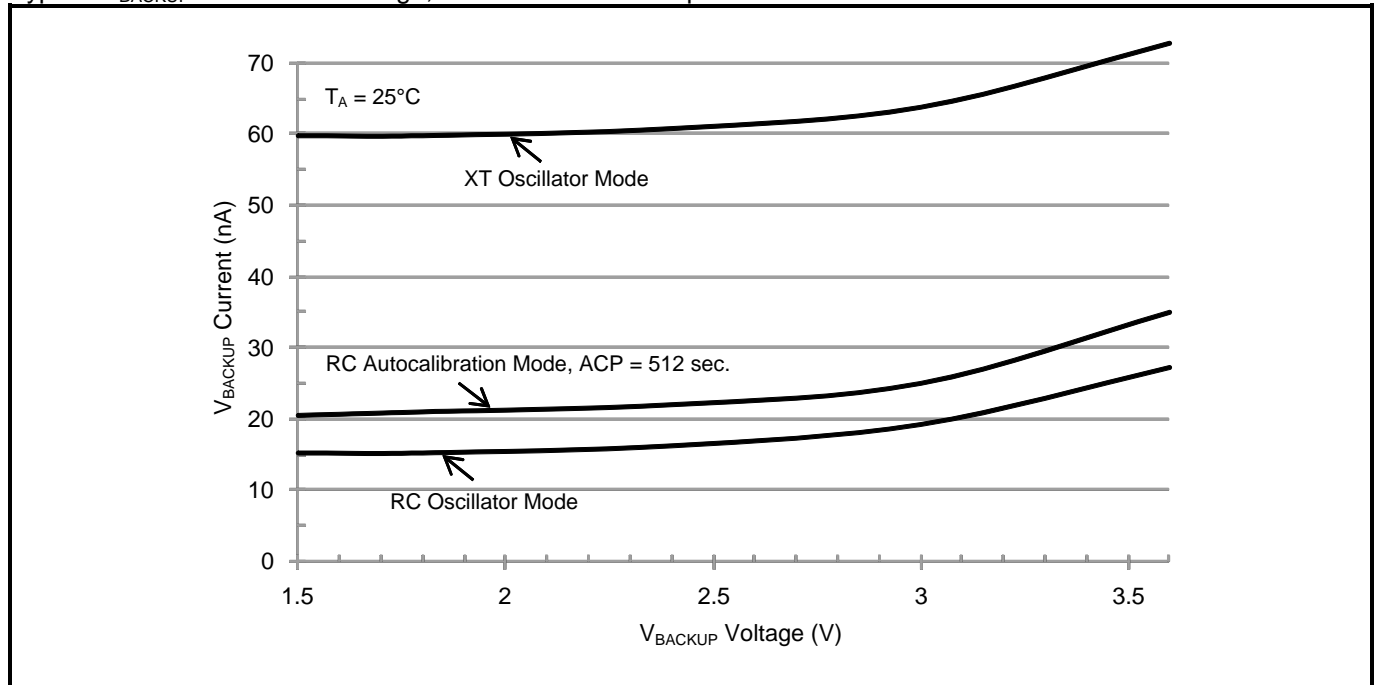

The following Figure shows the typical V_{BACKUP} current when operating in the VDD power state, V_{DD} = 1.7 V.

Typical V_{BACKUP} Current vs. Voltage in VDD Power State:

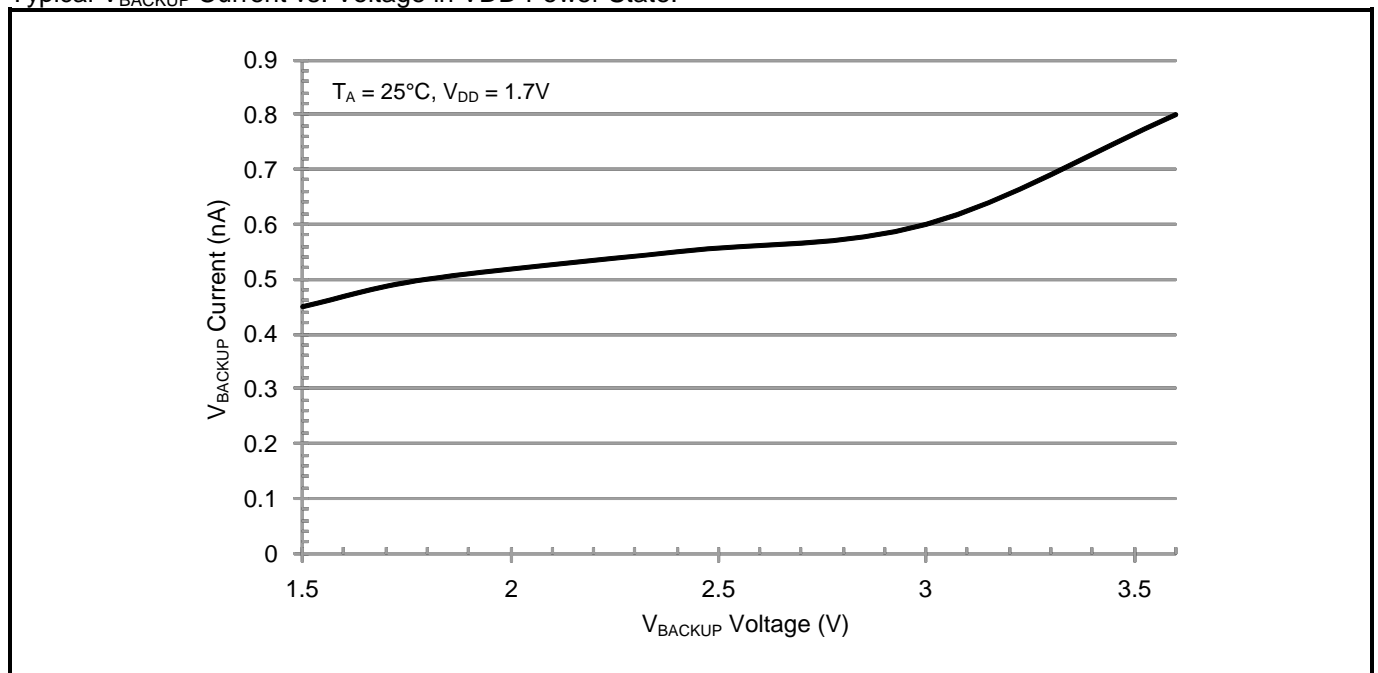

6.8. BREF ELECTRICAL CHARACTERISTICS

The following Table lists the parameters of the V_{BACKUP} voltage thresholds. BREF values other than those listed in the table are not supported. For this table, $T_A = -20\text{ }^{\circ}\text{C}$ to $70\text{ }^{\circ}\text{C}$, TYP values at $25\text{ }^{\circ}\text{C}$, $V_{\text{DD}} = 1.7$ to 3.6V .

BREF Parameters:

| SYMBOL | PARAMETER | BREF | MIN | TYP | MAX | UNIT |
|-------------------|---|-----------------------|-----|------|-----|--------------------|
| V_{BRF} | V_{BACKUP} falling threshold | 0111 | 2.3 | 2.5 | 3.3 | V |
| | | 1011 | 1.9 | 2.1 | 2.8 | |
| | | 1101 | 1.6 | 1.8 | 2.5 | |
| | | 1111 | | 1.4 | | |
| V_{BRR} | V_{BACKUP} rising threshold | 0111 | 2.6 | 3.0 | 3.4 | V |
| | | 1011 | 2.1 | 2.5 | 2.9 | |
| | | 1101 | 1.9 | 2.2 | 2.7 | |
| | | 1111 | | 1.6 | | |
| V_{BRH} | V_{BACKUP} threshold hysteresis | 0111 | | 0.5 | | V |
| | | 1011 | | 0.4 | | |
| | | 1101 | | 0.4 | | |
| | | 1111 | | 0.2 | | |
| t_{BREF} | BREF/BPOL change to BBOD valid | All valid BREF values | | 1000 | | ms |
| T_{BR} | V_{BACKUP} analog comparator recommended operating temperature range | | -20 | | 70 | $^{\circ}\text{C}$ |

6.9. I²C AC ELECTRICAL CHARACTERISTICS

The following Figure and Table describe the I²C AC electrical parameters.

I²C AC Parameter Definitions:

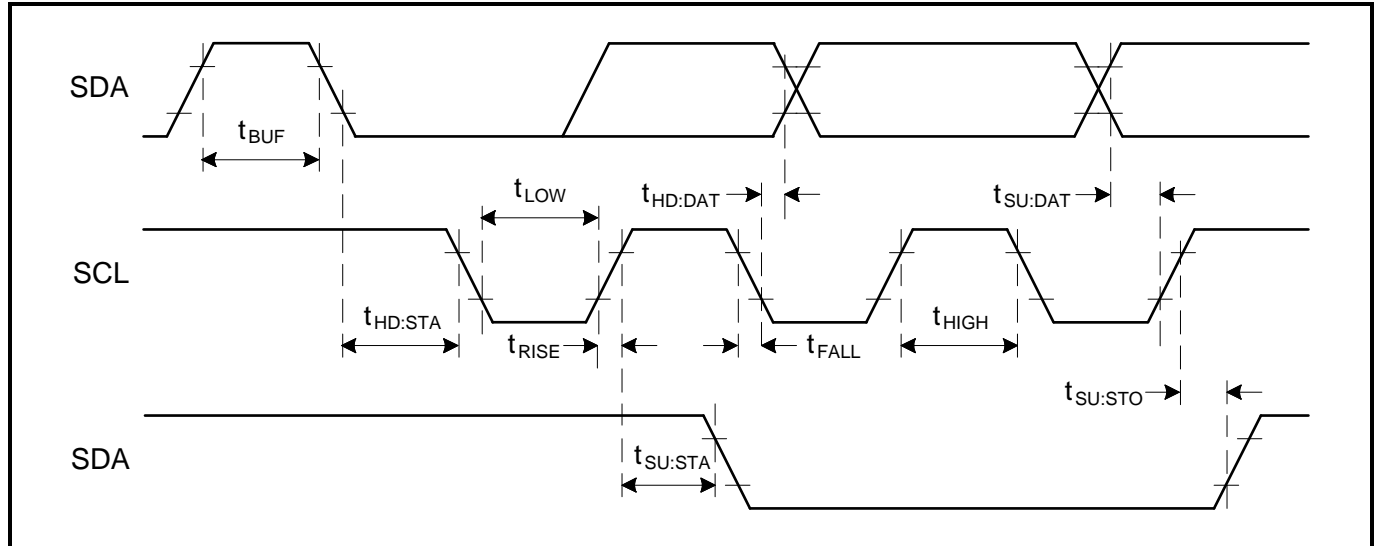

For the following Table, $T_A = -40\text{ }^{\circ}\text{C}$ to $85\text{ }^{\circ}\text{C}$, TYP values at $25\text{ }^{\circ}\text{C}$.

I²C AC Electrical Parameters:

| SYMBOL | PARAMETER | V _{DD} | MIN | TYP | MAX | UNIT |
|---------------------|---|-----------------|-----|-----|-----|------|
| f _{SCL} | SCL input clock frequency | 1.7V-3.6V | 10 | | 400 | kHz |
| t _{LOW} | Low period of SCL clock | 1.7V-3.6V | 1.3 | | | μs |
| t _{HIGH} | High period of SCL clock | 1.7V-3.6V | 600 | | | ns |
| t _{RISE} | Rise time of SDA and SCL | 1.7V-3.6V | | | 300 | ns |
| t _{FALL} | Fall time of SDA and SCL | 1.7V-3.6V | | | 300 | ns |
| t _{HD:STA} | START condition hold time | 1.7V-3.6V | 600 | | | ns |
| t _{SU:STA} | START condition setup time | 1.7V-3.6V | 600 | | | ns |
| t _{SU:DAT} | SDA setup time | 1.7V-3.6V | 100 | | | ns |
| t _{HD:DAT} | SDA hold time | 1.7V-3.6V | 0 | | | ns |
| t _{SU:STO} | STOP condition setup time | 1.7V-3.6V | 600 | | | ns |
| t _{BUF} | Bus free time before a new transmission | 1.7V-3.6V | 1.3 | | | μs |

6.10. POWER ON AC ELECTRICAL CHARACTERISTICS

The following Figure and Table describe the power on AC electrical characteristics for the CLK/ $\overline{\text{INT}}$ pin and XT oscillator.

Power On AC Electrical Characteristics:

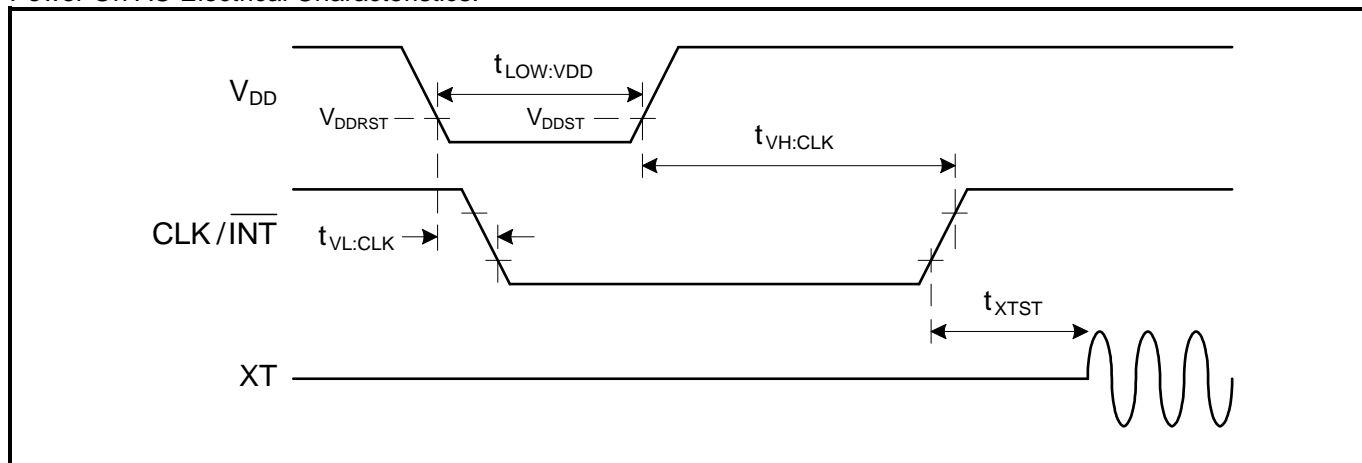

For the following Table, T_A = -40 °C to 85 °C, V_{BACKUP} < 1.2 V

Power On AC Electrical Parameters:

| SYMBOL | PARAMETER | V _{DD} | T _A | MIN | TYP | MAX | UNIT |
|----------------------|---|-----------------|----------------|-----|-----|-----|------|
| t _{LOW:VDD} | Low period of V _{DD} to insure a valid POR | 1.7V-3.6V | 85 °C | | 0.1 | | s |
| | | | 25 °C | | 0.1 | | |
| | | | -20 °C | | 1.5 | | |
| | | | -40 °C | | 10 | | |
| t _{VL:CLK} | V _{DD} low to CLK/ $\overline{\text{INT}}$ low | 1.7V-3.6V | 85 °C | | 0.1 | | s |
| | | | 25 °C | | 0.1 | | |
| | | | -20 °C | | 1.5 | | |
| | | | -40 °C | | 10 | | |
| t _{VH:CLK} | V _{DD} high to CLK/ $\overline{\text{INT}}$ high | 1.7V-3.6V | 85 °C | | 0.4 | | s |
| | | | 25 °C | | 0.5 | | |
| | | | -20 °C | | 3 | | |
| | | | -40 °C | | 20 | | |
| t _{XTST} | CLK/ $\overline{\text{INT}}$ high to XT oscillator start | 1.7V-3.6V | 85 °C | | 0.4 | | s |
| | | | 25 °C | | 0.4 | | |
| | | | -20 °C | | 0.5 | | |
| | | | -40 °C | | 1.5 | | |

6.11. $\overline{\text{RST}}$ AC ELECTRICAL CHARACTERISTICS

The following Figure and Table describe the $\overline{\text{RST}}$ AC electrical characteristics.

$\overline{\text{RST}}$ AC Parameter Characteristics:

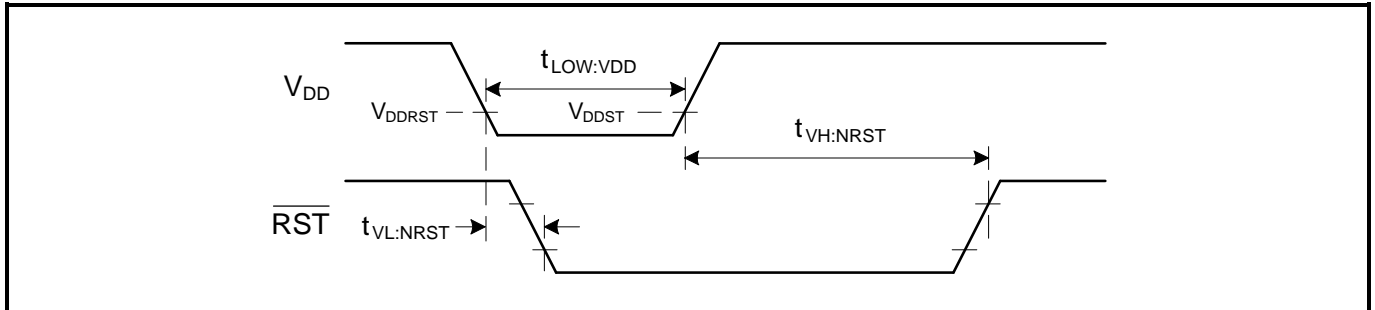

For the following Table, $T_A = -40\text{ }^\circ\text{C}$ to $85\text{ }^\circ\text{C}$, $V_{BACKUP} < 1.2\text{ V}$.

$\overline{\text{RST}}$ AC Electrical Parameters:

| SYMBOL | PARAMETER | V_{DD} | T_A | MIN | TYP | MAX | UNIT |
|---------------|---|-----------|-------|-----|-----|-----|------|
| $t_{LOW:VDD}$ | Low period of V_{DD} to insure a valid POR | 1.7V-3.6V | 85°C | | 0.1 | | s |
| | | | 25°C | | 0.1 | | |
| | | | -20°C | | 1.5 | | |
| | | | -40°C | | 10 | | |
| $t_{VL:NRST}$ | V_{DD} low to $\overline{\text{RST}}$ low | 1.7V-3.6V | 85°C | | 0.1 | | s |
| | | | 25°C | | 0.1 | | |
| | | | -20°C | | 1.5 | | |
| | | | -40°C | | 10 | | |
| $t_{VH:NRST}$ | V_{DD} high to $\overline{\text{RST}}$ high | 1.7V-3.6V | 85°C | | 0.5 | | s |
| | | | 25°C | | 0.5 | | |
| | | | -20°C | | 3.5 | | |
| | | | -40°C | | 25 | | |

7. APPLICATION INFORMATION

7.1. OPERATING RV-1805-C3

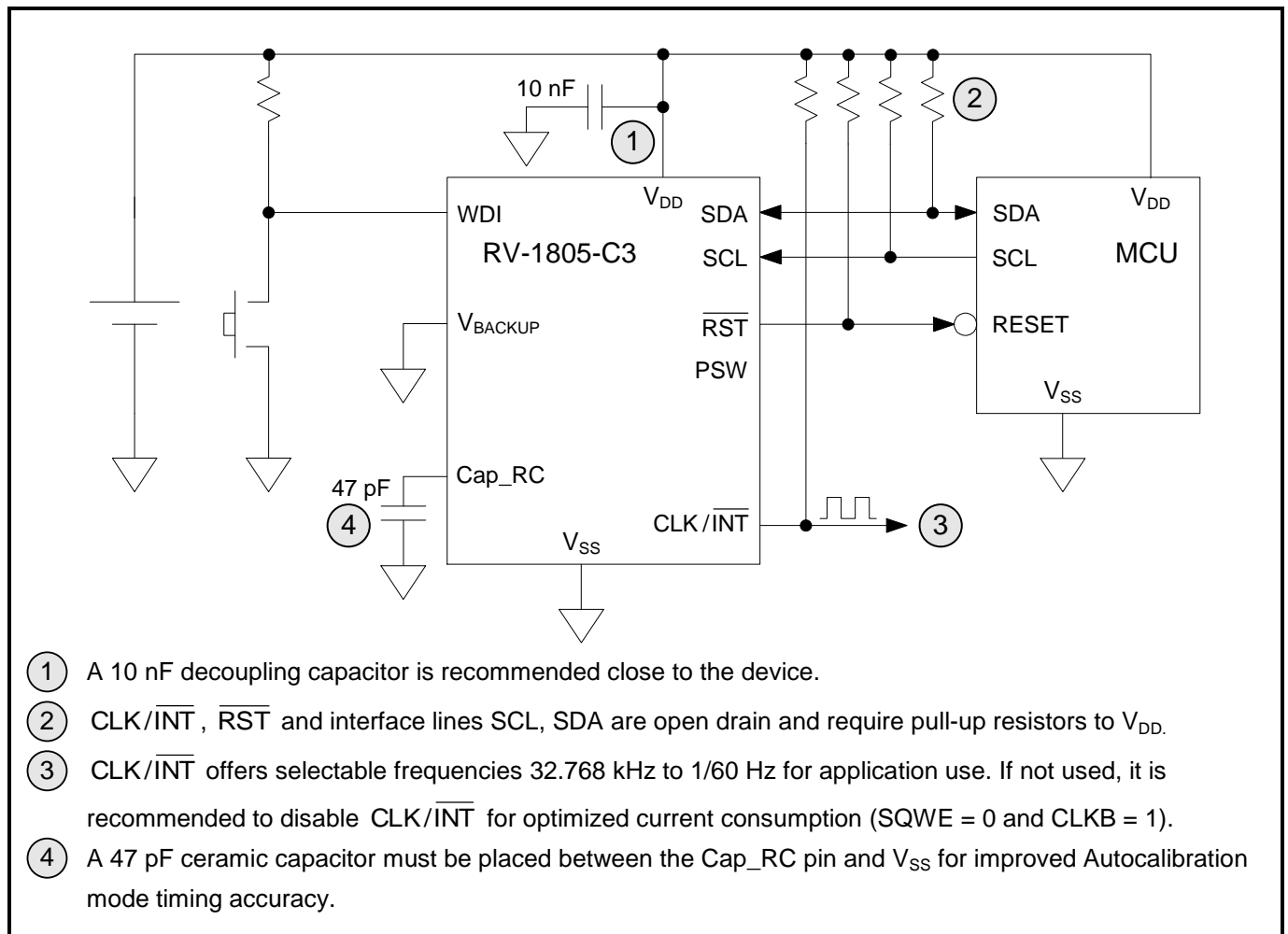

7.2. OPERATING RV-1805-C3 WITH BACKUP BATTERY/SUPERCAP

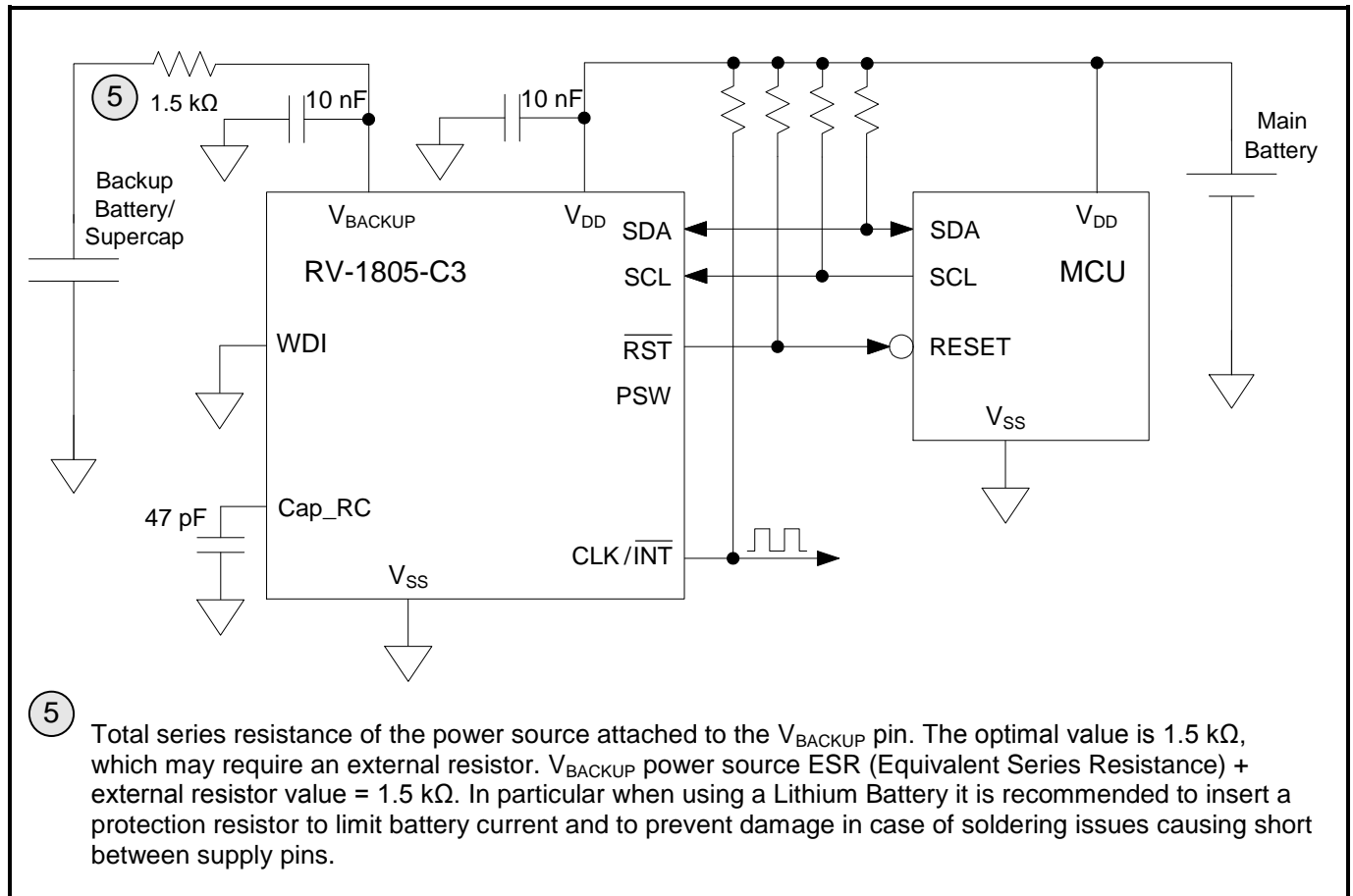

8. RECOMMENDED REFLOW TEMPERATURE (LEADFREE SOLDERING)

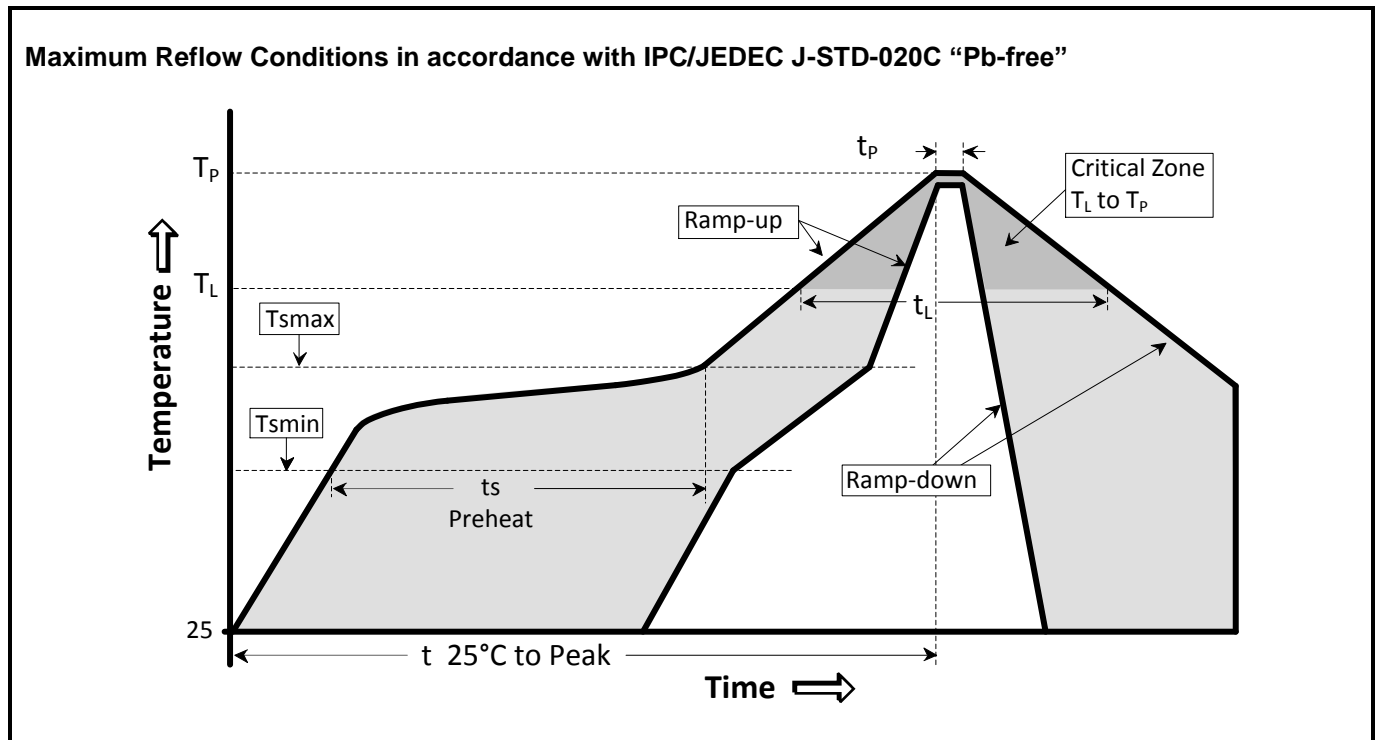

| Temperature Profile | Symbol | Condition | Unit |
|-------------------------------------|----------------------------|------------------|--------|
| Average ramp-up rate | ($T_{s_{max}}$ to T_p) | 3°C / second max | °C / s |
| Ramp down Rate | T_{cool} | 6°C / second max | °C / s |
| Time 25°C to Peak Temperature | $T_{to-peak}$ | 8 minutes max | min |
| Preheat | | | |
| Temperature min | $T_{s_{min}}$ | 150 | °C |
| Temperature max | $T_{s_{max}}$ | 200 | °C |
| Time $T_{s_{min}}$ to $T_{s_{max}}$ | t_s | 60 – 180 | sec |
| Soldering above liquidus | | | |
| Temperature liquidus | T_L | 217 | °C |
| Time above liquidus | t_L | 60 – 150 | sec |
| Peak temperature | | | |
| Peak Temperature | T_p | 260 | °C |
| Time within 5°C of peak temperature | t_p | 20 – 40 | sec |

9. PACKAGE

9.1. DIMENSIONS AND SOLDERPADS LAYOUT

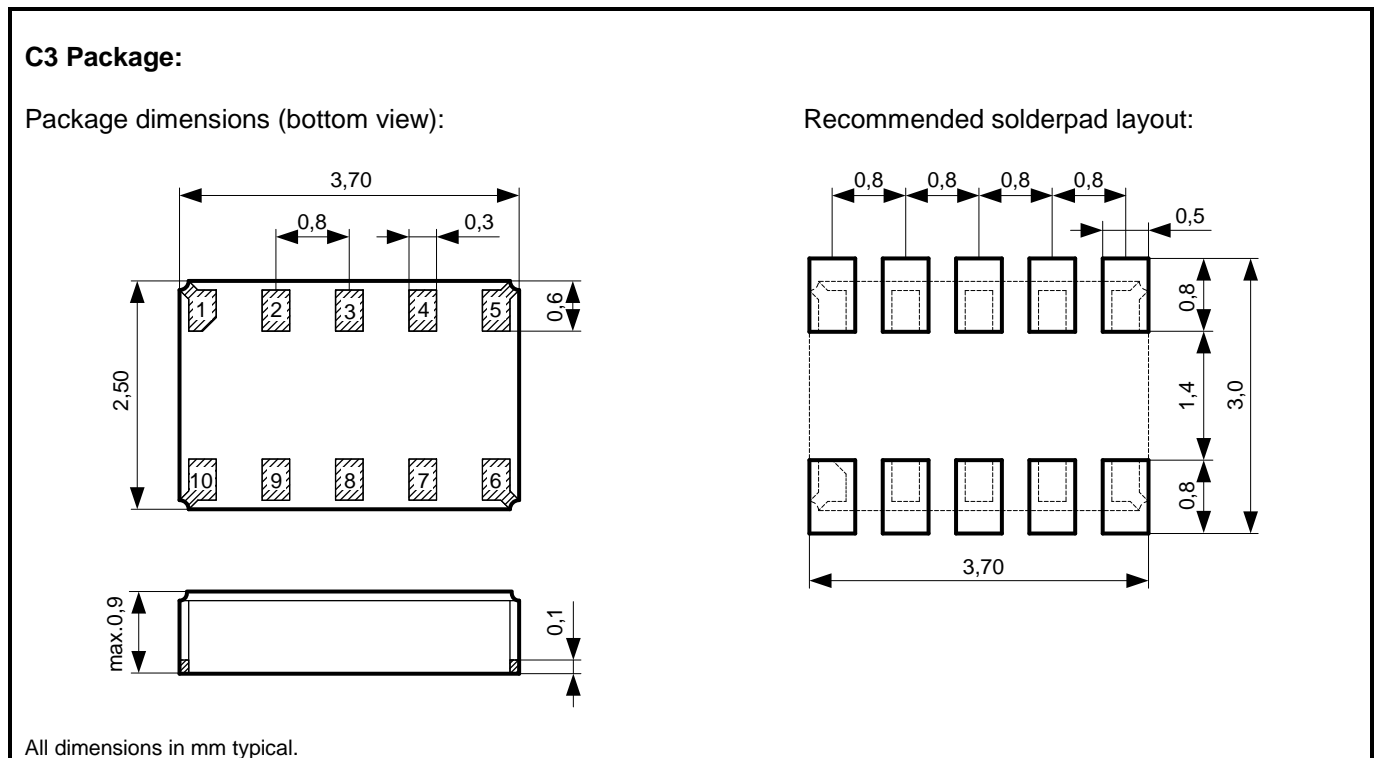

9.2. MARKING AND PIN #1 INDEX

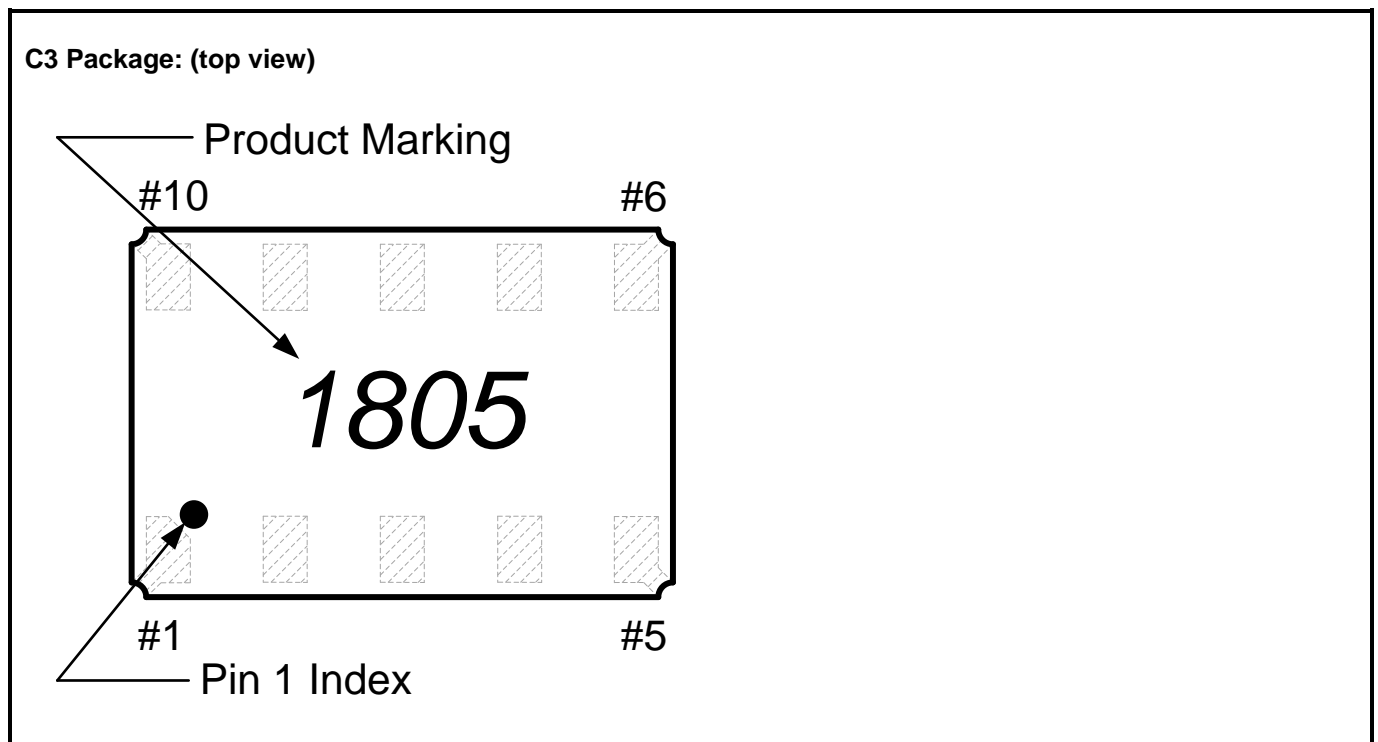

10. PACKING INFORMATION

10.1. CARRIER TAPE

12 mm Carrier-Tape: Material: Polystyrene / Butadine or Polystyrol black, conductive

Cover Tape: Base Material: Polyester, conductive 0.061 mm
 Adhesive Material: Pressure-sensitive Synthetic Polymer

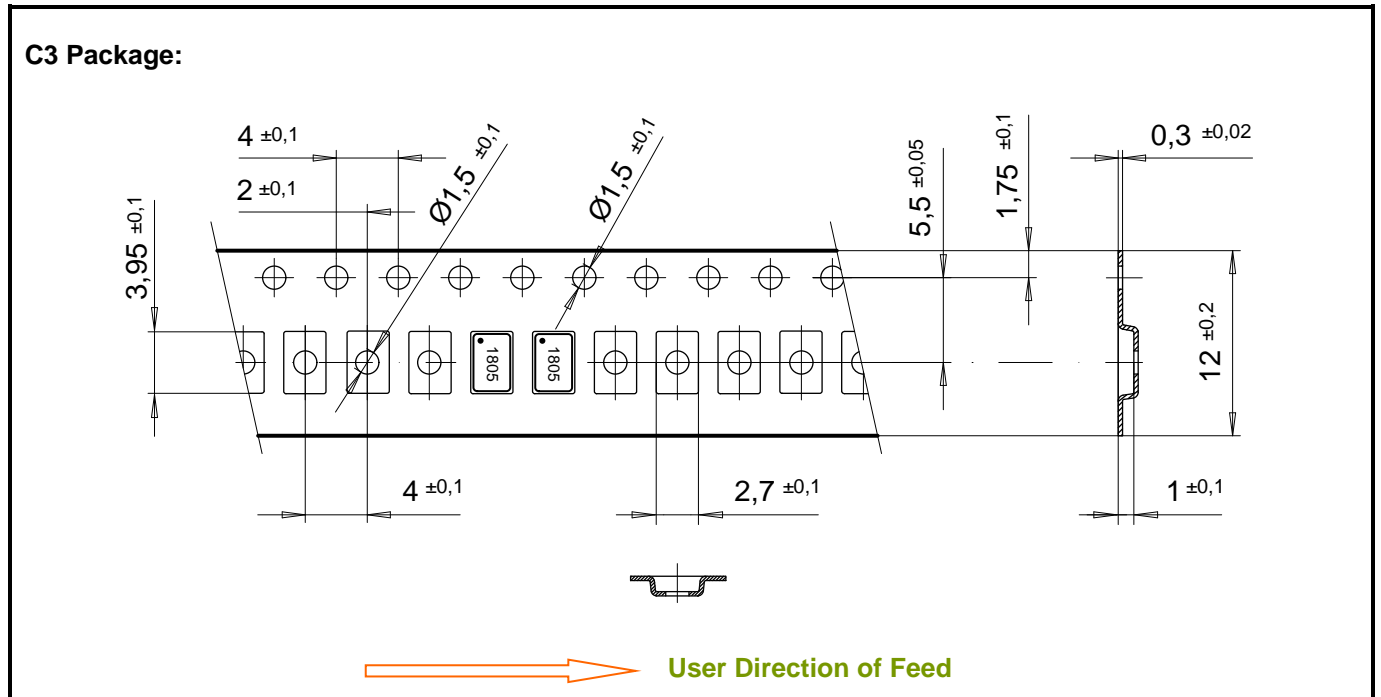

Tape Leader and Trailer: 300 mm minimum.
 All dimensions in mm.

10.2. PARTS PER REEL

C3 Package:

Reels:

| Diameter | Material | RTC's per reel |
|----------|---------------------|----------------|
| 7" | Plastic, Polystyrol | 1'000 |
| 7" | Plastic, Polystyrol | 3'000 |

10.3. REEL 7 INCH FOR 12 mm TAPE

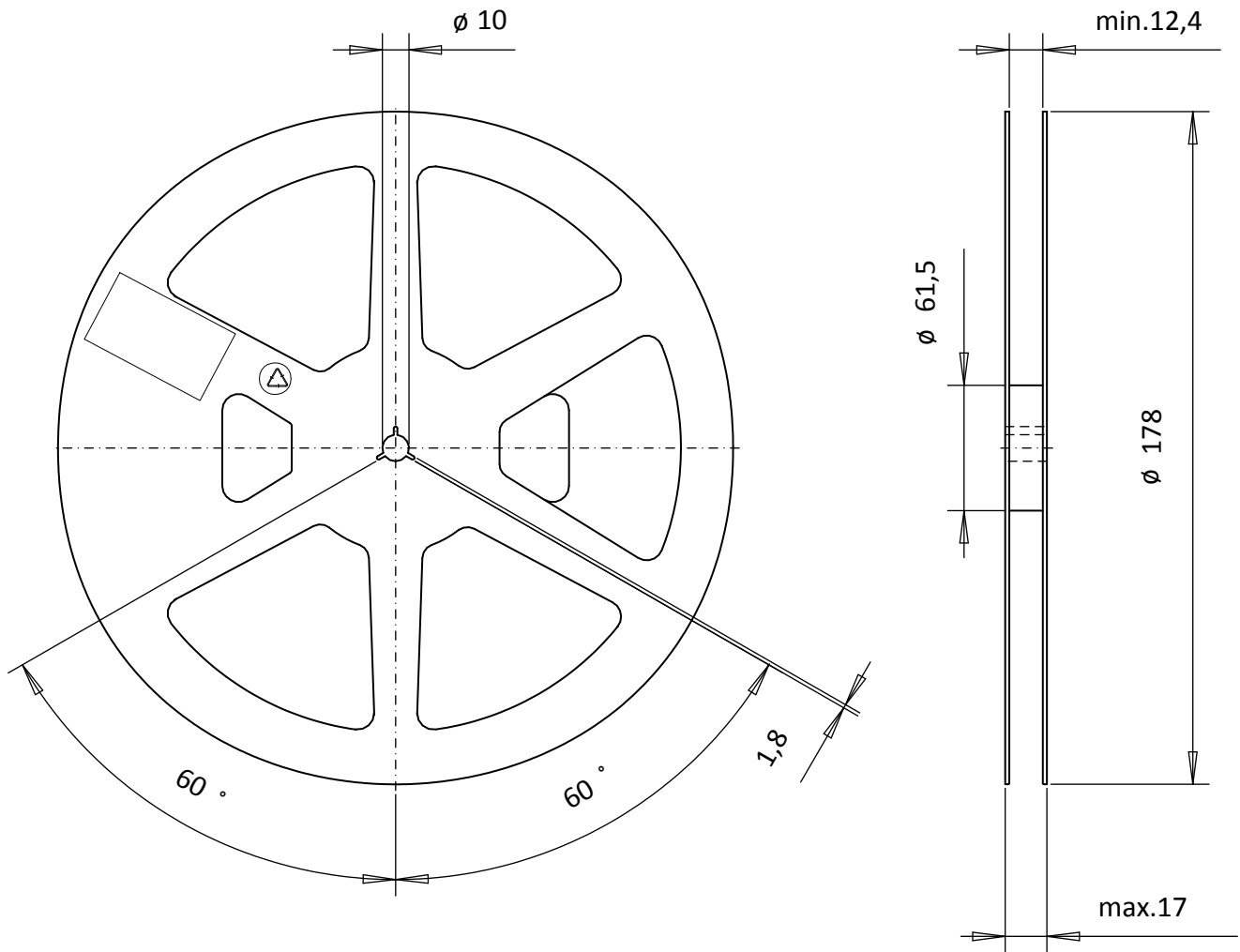

Reel:

| Diameter | Material |
|----------|---------------------|
| 7" | Plastic, Polystyrol |

10.4. HANDLING PRECAUTIONS FOR CRYSTALS OR MODULES WITH EMBEDDED CRYSTALS

The built-in tuning-fork crystal consists of pure Silicon Dioxide in crystalline form. The cavity inside the package is evacuated and hermetically sealed in order for the crystal blank to function undisturbed from air molecules, humidity and other influences.

Shock and vibration:

Keep the crystal / module from being exposed to **excessive mechanical shock and vibration**. Micro Crystal guarantees that the crystal / module will bear a mechanical shock of 5000g / 0.3 ms.

The following special situations may generate either shock or vibration:

Multiple PCB panels - Usually at the end of the pick & place process the single PCBs are cut out with a router. These machines sometimes generate vibrations on the PCB that have a fundamental or harmonic frequency close to 32.768 kHz. This might cause breakage of crystal blanks due to resonance. Router speed should be adjusted to avoid resonant vibration.

Ultrasonic cleaning - Avoid cleaning processes using ultrasonic energy. These processes can damage crystals due to mechanical resonance of the crystal blank.

Overheating, rework high temperature exposure:

Avoid overheating the package. The package is sealed with a seal ring consisting of 80% Gold and 20% Tin. The eutectic melting temperature of this alloy is at 280°C. Heating the seal ring up to >280°C will cause melting of the metal seal which then, due to the vacuum, is sucked into the cavity forming an air duct. This happens when using hot-air-gun set at temperatures >300°C.

Use the following methods for rework:

- Use a hot-air- gun set at 270°C.
- Use 2 temperature controlled soldering irons, set at 270°C, with special-tips to contact all solder-joints from both sides of the package at the same time, remove part with tweezers when pad solder is liquid.

11. DOCUMENT REVISION HISTORY

| Date | Revision # | Revision Details |
|--------------|------------|--|
| July 2014 | 2.0 | First release |
| January 2015 | 2.1 | <ul style="list-style-type: none"> - Changed 41 variable names - Updated Register Function Descriptions - Completed Standard and Alternate RAM - Added two's complement and ppm values for OFFSETX and OFFSETR - Modified application examples (PSW pin) - Modified interrupt names - Completed INTERRUPT SUMMARY - Completed Digital Architecture Summary - Completed Sleep State Machine - Added SLW table - Clarified DETAILED FUNCTIONAL DESCRIPTION - Completed XT OSCILLATOR DIGITAL CALIBRATION - Completed RC OSCILLATOR DIGITAL CALIBRATION - Modified Basic Mode Comparison diagram - Completed OPERATING RV-1805-C3 WITH BACKUP BATTERY/SUPERCAP - Added additional text to PWGT bit description - Specified V_{DD} voltage range for I_{OLEAK} parameter - Clarified PIN DESCRIPTION |

Information furnished is believed to be accurate and reliable. However, Micro Crystal assumes no responsibility for the consequences of use of such information nor for any infringement of patents or other rights of third parties which may result from its use. In accordance with our policy of continuous development and improvement, Micro Crystal reserves the right to modify specifications mentioned in this publication without prior notice. This product is not authorized for use as critical component in life support devices or systems.



Стандарт Электрон Связь

Мы молодая и активно развивающаяся компания в области поставок электронных компонентов. Мы поставляем электронные компоненты отечественного и импортного производства напрямую от производителей и с крупнейших складов мира.

Благодаря сотрудничеству с мировыми поставщиками мы осуществляем комплексные и плановые поставки широчайшего спектра электронных компонентов.

Собственная эффективная логистика и склад в обеспечивает надежную поставку продукции в точно указанные сроки по всей России.

Мы осуществляем техническую поддержку нашим клиентам и предпродажную проверку качества продукции. На все поставляемые продукты мы предоставляем гарантию .

Осуществляем поставки продукции под контролем ВП МО РФ на предприятия военно-промышленного комплекса России , а также работаем в рамках 275 ФЗ с открытием отдельных счетов в уполномоченном банке. Система менеджмента качества компании соответствует требованиям ГОСТ ISO 9001.

Минимальные сроки поставки, гибкие цены, неограниченный ассортимент и индивидуальный подход к клиентам являются основой для выстраивания долгосрочного и эффективного сотрудничества с предприятиями радиоэлектронной промышленности, предприятиями ВПК и научно-исследовательскими институтами России.

С нами вы становитесь еще успешнее!

Наши контакты:

Телефон: +7 812 627 14 35

Электронная почта: sales@st-electron.ru

Адрес: 198099, Санкт-Петербург,
Промышленная ул, дом № 19, литера Н,
помещение 100-Н Офис 331