

SmartGM862™

Manual

All MikroElektronika's development systems represent irreplaceable tools for programming and developing microcontroller-based devices. Carefully chosen components and the use of machines of the last generation for mounting and testing thereof are the best guarantee of high reliability of our devices. Due to simple design, a large number of add-on modules and ready to use examples, all our users, regardless of their experience, have the possibility to develop their projects in a fast and efficient way.

Development System

 **MikroElektronika**

SOFTWARE AND HARDWARE SOLUTIONS FOR EMBEDDED WORLD ...making it simple

SmartGM862

The SmartGM862 Board is a full-featured development tool for the Telit's GM862 GSM/GPRS module. This board has everything you need to develop your own GSM-GPRS based device.

Key features:

- Data transfer via Telit GM862 module;
- Microphone and speaker connectors;
- UART communication with microcontroller;
- 7-23V AC or 9-32V DC power supply voltage;

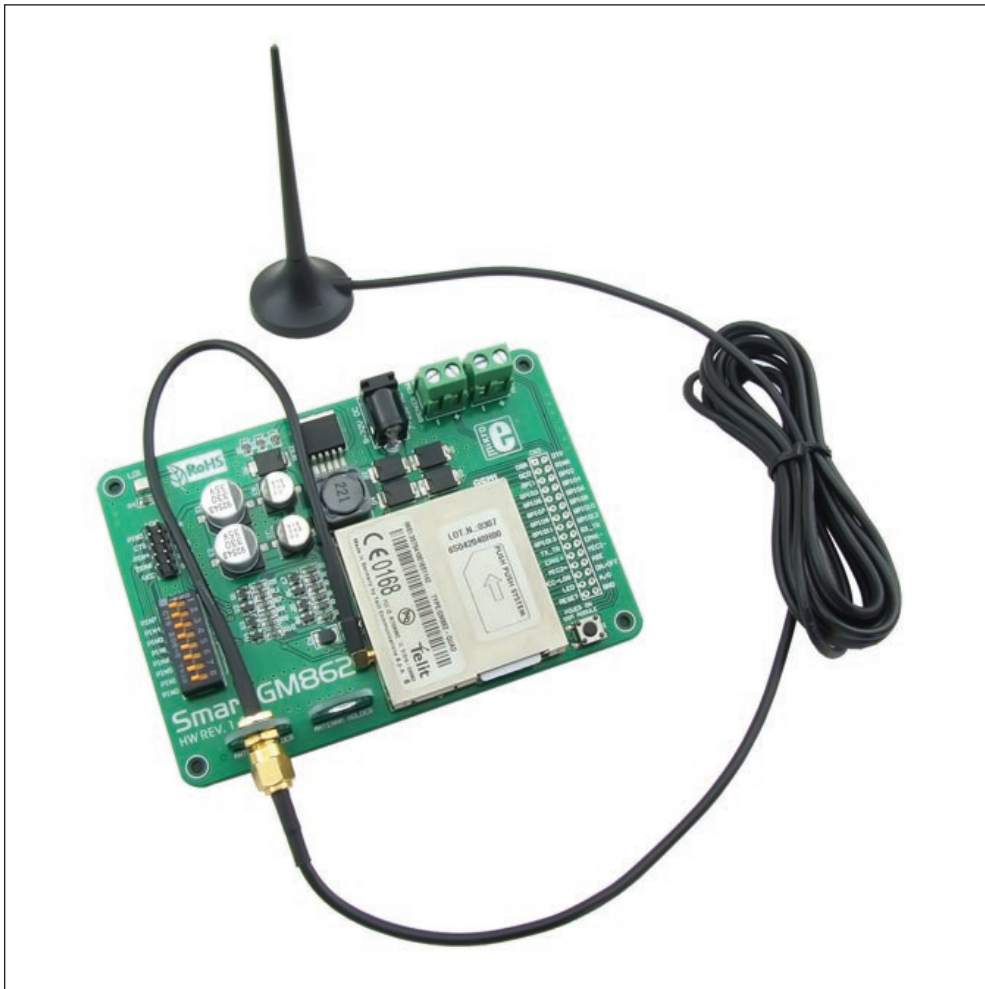

Figure 1: SmartGM862 with Telit GM862 module

How to connect the board?

The SmartGM862 is designed for use with Mikroelektronika's development systems. To make connection between development system and SmartGM862 use flat cable with IDC10 connector and make connection between 2x5 male header on development system port and 2x5 male header CN1 on SmartGM862. Which port on development system will be used depends on position of MCU pins which are used for UART communication. When connection is established, depending which development system is in use, turn ON appropriate switch on DIP switch SW1, Table 1.

Development system	SmartGM862 CN1 pin	UART pin
PIC/PIC18FJ	PIN7	RX
dsPIC30/33/PIC24	PIN4	RX
AVR/8051	PIN0	RX
ARM	PIN1	RX
PIC/PIC18FJ	PIN6	TX
dsPIC30/33/PIC24	PIN5	TX
AVR/8051	PIN1	TX
ARM	PIN0	TX

Table 1: DIP switch SW1 position

In order to supply SmartGM862 with power it is necessary to connect external power supply via AC/DC connector CN2. Power supply voltage can be in range between 7 to 23V AC or 9 to 32V DC. As indication that power supply is connected LED marked with LD1 will be turned on. To connect microphone with SmartGM862 use screw terminal CN4 which is marked with “-” and “+”. On “-” side of screw terminal connect minus phase, and on “+” side connect plus phase of the microphone. In order to connect speaker use screw terminal CN5. “-” side of screw terminal is used for minus phase and “+” is used for plus phase of speaker. If you want to access Telit GM862 module pins on SmartGM862 board you can use marked pads CN3. To power up Telit GM862 module is necessary to press and hold push button marked with “POWER ON GSM MODULE” for 1s.

How to use the board?

In order to use SmartGM862 it is necessary to place Telit GM862 module on board. After that connect antenna with Telit GM862 module, Figure 1. Now connect SmartGM862 with development system as described in previous section. Write program and upload it to MCU on development system. Program example can be found on:
<http://www.mikroe.com/eng/products/view/468/smartgm862-board/>

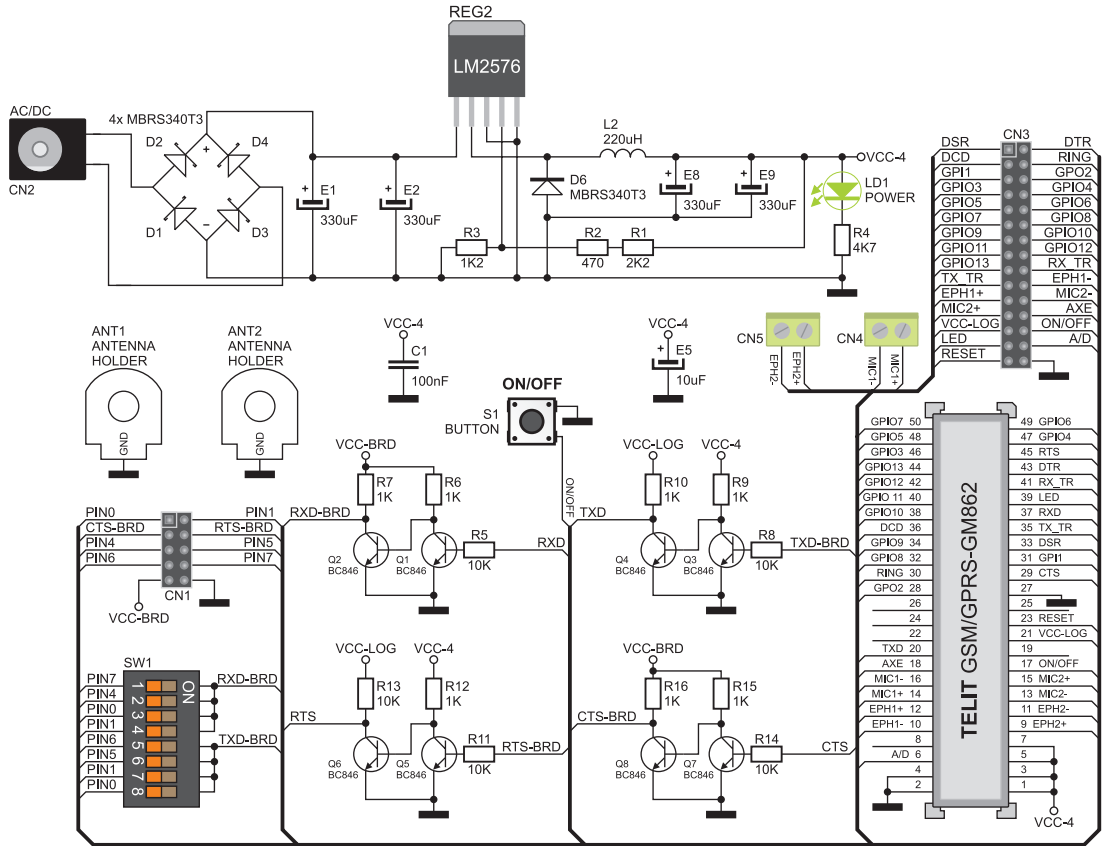

Figure 4: SmartGM862 connection schematics



MikroElektronika

SOFTWARE AND HARDWARE SOLUTIONS FOR EMBEDDED WORLD ...making it simple

If you want to learn more about our products, please visit our website at www.mikroe.com

If you are experiencing some problems with any of our products or just need additional information, please place your ticket at www.mikroe.com/en/support

If you have any questions, comments or business proposals, do not hesitate to contact us at office@mikroe.com



Стандарт Электрон Связь

Мы молодая и активно развивающаяся компания в области поставок электронных компонентов. Мы поставляем электронные компоненты отечественного и импортного производства напрямую от производителей и с крупнейших складов мира.

Благодаря сотрудничеству с мировыми поставщиками мы осуществляем комплексные и плановые поставки широчайшего спектра электронных компонентов.

Собственная эффективная логистика и склад в обеспечивает надежную поставку продукции в точно указанные сроки по всей России.

Мы осуществляем техническую поддержку нашим клиентам и предпродажную проверку качества продукции. На все поставляемые продукты мы предоставляем гарантию .

Осуществляем поставки продукции под контролем ВП МО РФ на предприятия военно-промышленного комплекса России , а также работаем в рамках 275 ФЗ с открытием отдельных счетов в уполномоченном банке. Система менеджмента качества компании соответствует требованиям ГОСТ ISO 9001.

Минимальные сроки поставки, гибкие цены, неограниченный ассортимент и индивидуальный подход к клиентам являются основой для выстраивания долгосрочного и эффективного сотрудничества с предприятиями радиоэлектронной промышленности, предприятиями ВПК и научно-исследовательскими институтами России.

С нами вы становитесь еще успешнее!

Наши контакты:

Телефон: +7 812 627 14 35

Электронная почта: sales@st-electron.ru

Адрес: 198099, Санкт-Петербург,
Промышленная ул, дом № 19, литера Н,
помещение 100-Н Офис 331