

## DC - 7 GHZ FRACTIONAL-N DIVIDER AND FREQUENCY SWEEPER

### Typical Applications

The HMC983LP5E is suitable for:

- Test Equipment
- Portable Instruments
- High Performance Fractional-N Frequency Synthesizers with Ultra Low Spurious
- Stand-Alone Divider and/or Delta-Sigma Modulator

### Features

Wideband: DC - 7 GHz Input  
-20-bit Frequency Divider

Low Noise: -160 dBc/Hz

Low Spurious: Largest Spurious - 95 dBc

48-bit 100 MHz Delta-Sigma Modulator (DSM)  
- Configurable DSM Size  
- Programmable Seed

### Features (Continued)

Integrated Frequency Sweeper

- Linear, Coherent Sweeps
- 2-Way, 1-Way, & User Defined Sweep Modes
- Automatic or Triggered
- Programmable Seed
- SPI & External Triggering

5-GPIO's, can be used for External DSM

Cycle Slip Prevention Support with PFD Chip (HMC984LP4E)

Differential VCO Input & Divider Output

Programmable Output Current Control:  
-5 mA to 17.5 mA Open Collector Output Driver

32 pin, 5 x 5 mm, LP5 Package

### Functional Diagram

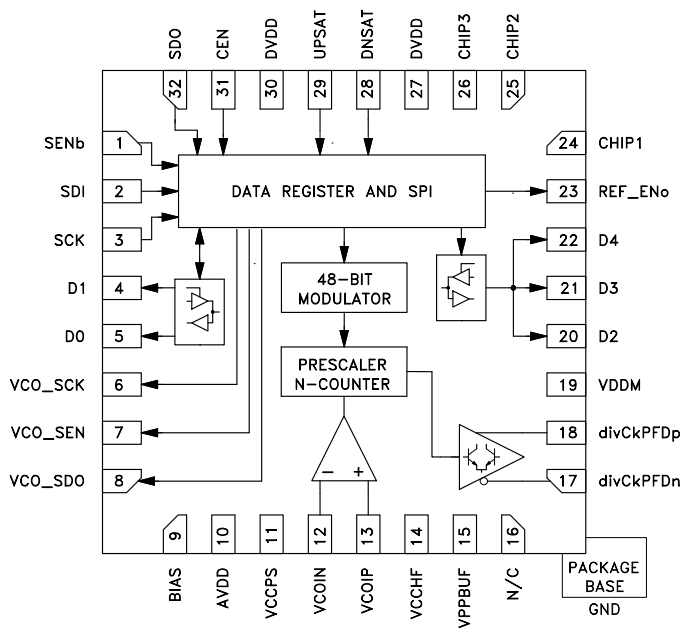

### General Description

HMC983LP5E is a fractional frequency divider targeted for fractional-N frequency synthesis, and stand-alone low noise frequency divider applications that require exceptional spurious performance.

Although the HMC983LP5E can work with any VCO and/or compatible Phase Detector, best performance and features will be achieved when paired with the companion part, the HMC984LP4E.

Fabricated in SiGe BiCMOS process, the HMC983LP5E features a 48-bit Delta Sigma Fractional Modulator (DSM) with programmable phase accumulator size, enabling precise control of frequency step size and resolution. Integrated DSM can generate frequencies with nearly 0 Hz frequency error. The DSM also includes a built-in programmable frequency sweep capability, with various automatic and user defined sweep modes and triggering options, including hardware trigger pin, or SPI trigger with optional delayed trigger.

HMC983LP5E is a versatile part capable of various configurations. It has 5 general purpose I/Os (GPIOs). DSM outputs are made available from the GPIO port, enabling the HMC983LP5E to import and/or export DSM sequences for various configuration options.

HMC983LP5E divider outputs are differential, open collector with programmable current to accommodate different off-chip loads.

**DC - 7 GHZ FRACTIONAL-N DIVIDER  
AND FREQUENCY SWEEPER**
**Table 1. Electrical Specifications**

TA = +25 °C, AVDD, VCCPS, VCCHF, VDDM, DVDD = 3 V ± 10%; VPPBUF = 5 V ± 10%; GND = 0 V

Parameter	Conditions	Min.	Typ.	Max.	Units
<b>RF Input Characteristics</b>					
RF Input Frequency range		DC		7	GHz
RF Input Sensitivity		-15	-10	0	dBm
RF Input Capacitance	External Match Recommended			3	pF
Divider Range (20-bit)					
Integer Mode		32		1,048,575	
Fractional Mode		36		1,048,571	
<b>Divider Output Characteristics</b>					
Output Buffer Current	Programmable in 2.5 mA Steps	5	12.5	17.5	mA
Output Voltage Swing	Single- Ended, Vpullup = 5 V	0.75	1	2	V
Output Frequency Range	Mode A and Mode B	DC		150	MHz
Integer Mode		DC		125	
Phase Noise	50 MHz PFD, 6 GHz Input, Integer Mode		-160		dBc/Hz
Fractional Spurious	Largest observed at 10 kHz Fractional Offset from Integer Boundary		-95	-85	dBc
<b>Logic Inputs</b>					
Input High Voltage (VIH)				DVDD-0.4	V
Input Low Voltage (VIL)		0.4			V
<b>Logic Outputs</b>					
Output High Voltage (VOH)				DVDD-0.4	V
Output Low Voltage (VOL)		0.4			V
DC Load				1.5	mA
Serial Port Clock Frequency	Main SPI and AUXSPI			30	MHz
<b>Power Supplies</b>					
AVDD, VCCPS, VCCHF	Analog Supplies. AVDD should be equal to DVDD.	2.7	3	3.3	V
VPPBUF	Output Buffer Supply.	4.5	5	5.5	V
VDDM, DVDD	Digital Supplies	2.7	3	3.3	V
<b>Current Consumption</b>					
IDD - Total Current Consumption	Integer Mode / Fractional Mode (50 MHz Divider Output)		104 / 122		mA
I - AVDD (AVDD Current, 3 V)	Integer Mode / Fractional Mode		5 / 5		mA
I - VCCPS (VCCPS Current, 3 V)	Integer Mode / Fractional Mode		79 / 79		mA
I - VCCHF (VCCHF Current, 3 V)	Integer Mode / Fractional Mode		8 / 8		mA
I - VDDM (VDDM Current, 3 V)	Integer Mode / Fractional Mode		11 / 11		mA
I - DVDD (Total DVDD Current, 3 V)	Integer Mode / Fractional Mode		1 / 19		mA
I - VPPBUF (Total VPPBUF Current, 5 V)			5		uA



## DC - 7 GHz FRACTIONAL-N DIVIDER AND FREQUENCY SWEEPER

**Figure 1. RF Input Sensitivity** [1]

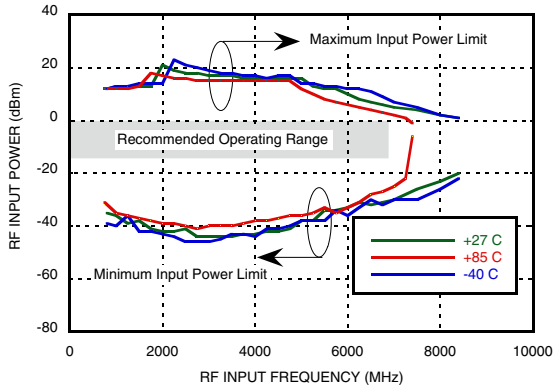

**Figure 2. Output Phase Noise, 6 GHz Input Frequency** [2]

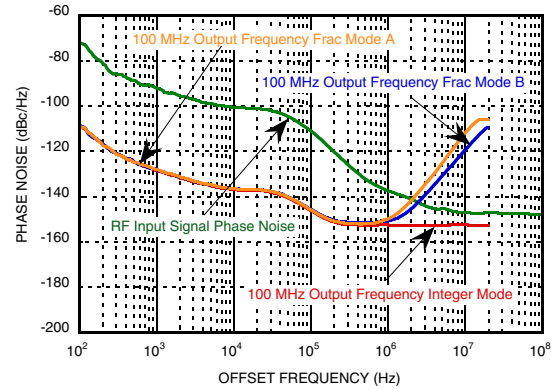

**Figure 3. Output Phase Noise with 6 GHz Input in Integer Mode** [3]

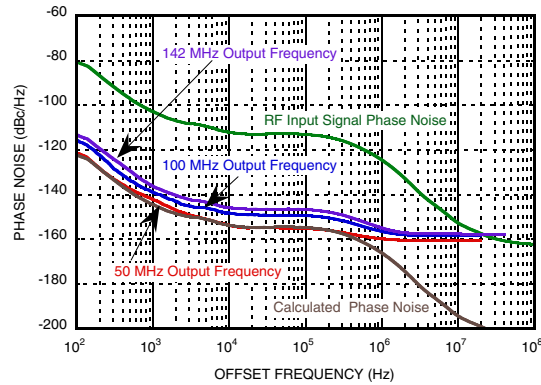

**Figure 4. Time Domain 10 MHz Output, 6.5 GHz Input** [4]

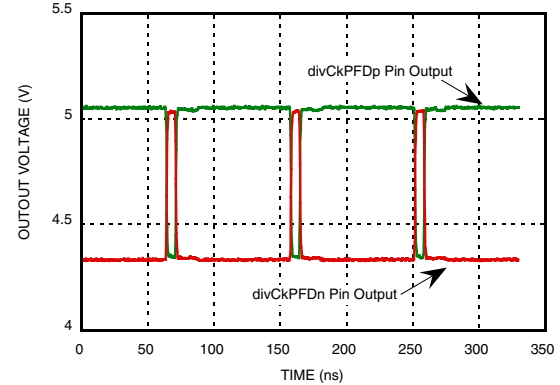

**Figure 5. Time Domain 18 MHz Output, 6.5 GHz Input** [4]

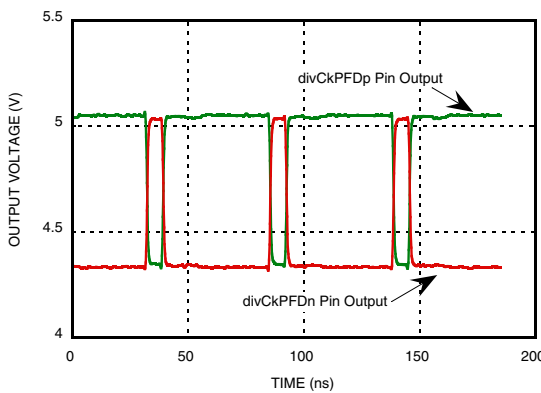

**Figure 6. Time Domain 35 MHz Output, 6.5 GHz Input** [4]

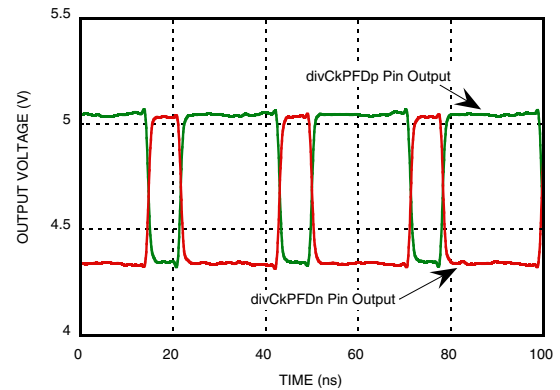

[1] The maximum and minimum levels indicate operational limits of the HMC983LP5E. Performance may degrade with input power greater than 0 dBm for frequencies higher than 6500 MHz.

[2] Due to Delta Sigma modulation in fractional mode, the output phase noise peaks at frequency offset of  $f_{out}/2$  from the output. Agilent MXG N5182A used as a signal source.

[3] Rohde & Schwarz SMBV100A used as a signal source.

[4] Measured with 50  $\Omega$  impedance per line, integer Mode, 15 mA Output Buffer Current ([Reg 0Fh](#)[4:2]) selected



**DC - 7 GHz FRACTIONAL-N DIVIDER AND FREQUENCY SWEEPER**

**Figure 7. Time Domain 124 MHz Output, 6.5 GHz Input [5]**

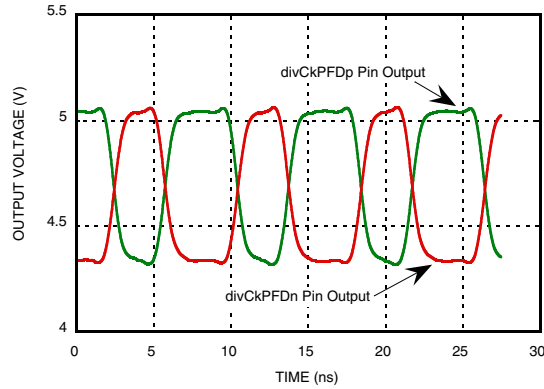

**Figure 8. Time Domain 66 MHz Output, 6.5 GHz Input [5]**

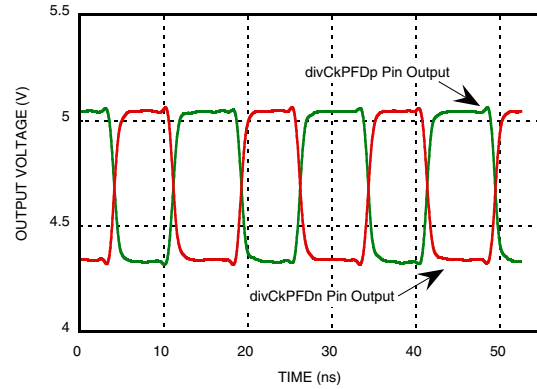

**Figure 9. Time Domain 61 MHz Output, 6.5 GHz Input [5]**

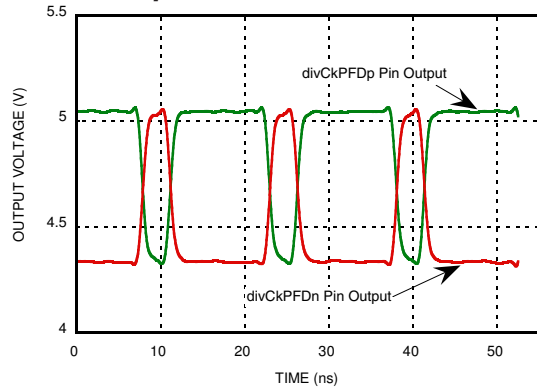

**Figure 10. Time Domain 66 MHz Output, 6.5 GHz Input [5]**

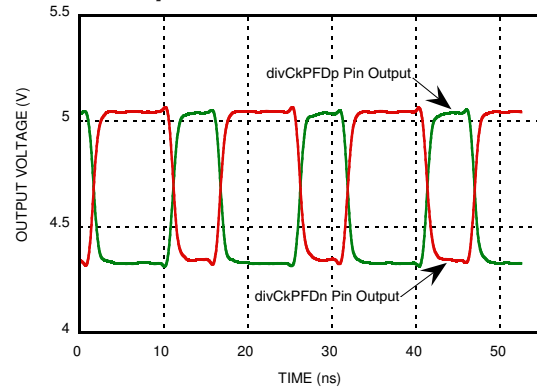

**Figure 11. 10 MHz Output Swing vs Buffer Current [6]**

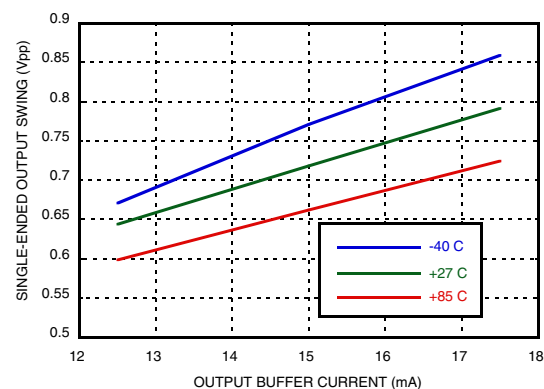

**Figure 12. 50 MHz Output Swing vs Buffer Current [6]**

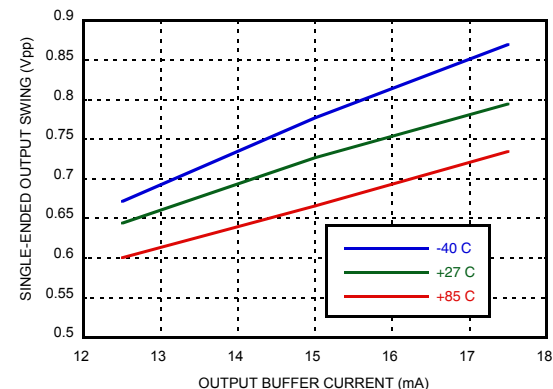

[5] Measured with 50 Ω impedance per line, integer Mode, 15 mA Output Buffer Current (Reg 0Fh[4:2]) selected

[6] Measured with 50 Ω impedance per line. Buffer current is controlled via Reg 0Fh[4:2].

## DC - 7 GHZ FRACTIONAL-N DIVIDER AND FREQUENCY SWEEPER

**Figure 13. 100 MHz Output Swing vs Buffer Current** [7]

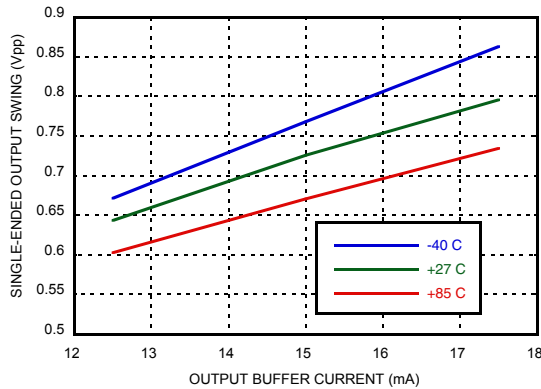

**Figure 14. Input Return Loss**

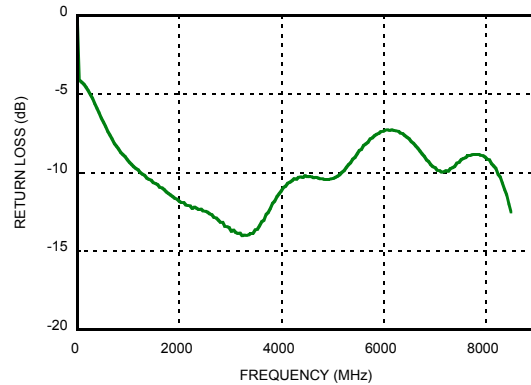

**Figure 15. Two Way Frequency Sweep, 50 MHz PFD** [8]

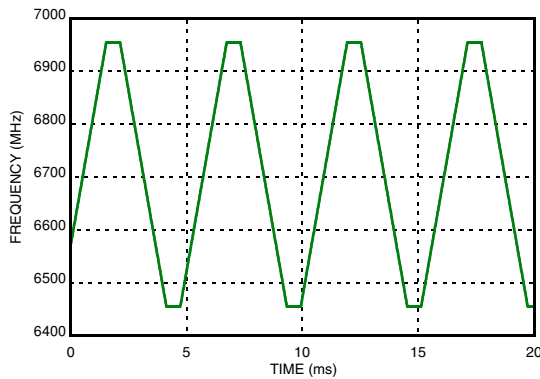

**Figure 16. One Way Frequency Sweep, 10 MHz PFD and 10 Hz external trigger** [8]

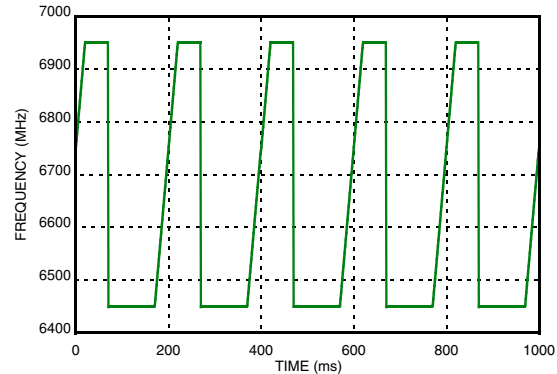

**Figure 17. PLL Cycle Slip Prevention, 100 MHz PFD** [8]

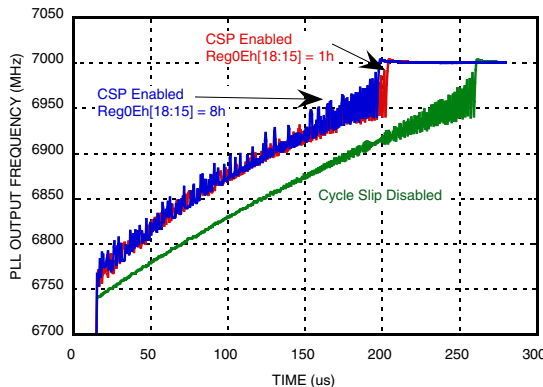

**Figure 18. PLL Cycle Slip Prevention, 50 MHz PFD** [8]

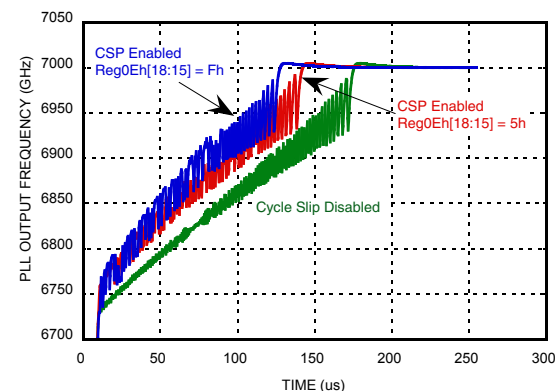

[7] Measured with 50 Ω impedance per line. Buffer current is controlled via [Reg 0Fh\[4:2\]](#).

[8] Measured with HMC983LP5E/HMC984LP4E chip set as fractional-N synthesizer. Crystal input frequency = 100 MHz, CP current = 2.5 mA, CP offset current = 245 uA, Loop filter bandwidth = 87 KHz, DSM Mode B selected. Cycle Slip Prevention (CSP) is disabled in HMC984LP4E by setting [Reg 01h](#) [4] = 0. Setting [Reg 01h](#) [4] = 1 enables CSP in the two chip PLL.

## DC - 7 GHZ FRACTIONAL-N DIVIDER AND FREQUENCY SWEEPER

**Table 2. Pin Descriptions**

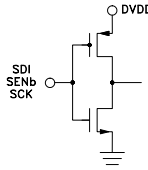
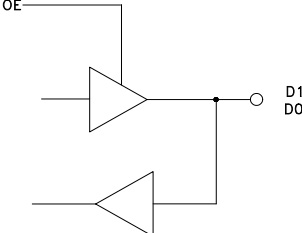
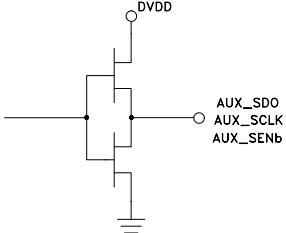
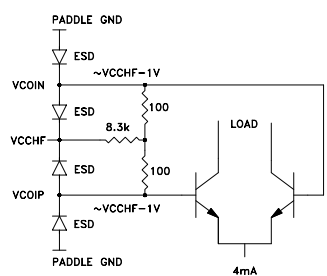
Pin Number	Function	Description	Interface Schematic
1, 2, 3	SENb SDI SCK	Main SPI Data Input	
4, 5	D1 D0	GPIO bit 1 GPIO bit 0	
6, 7, 8	AUX_SCLK AUX_SENb AUX_SDO	Auxiliary SPI Clock Output Auxiliary SPI Enable Auxiliary SPI Data Output	
9	BIAS	External Decoupling for Analog Bias Circuits	
10	AVDD	3 Volt Power Supply Pin for Internal Reference Current Sources	
11	VCCPS	3 Volt Power Supply Pin for Prescaler	
12, 13	VCOIN, VCIOP	Negative Pin for Prescaler Differential Input, AC-Coupled Positive Pin for Prescaler Differential Input, AC-Coupled	
14	VCCHF	3 Volt Power Supply Pin for Prescaler Input Buffer	
15	VPPBUF	5 Volt Power Supply Pin for Divider Output Buffer	
16	N/C	No Connect Pin	

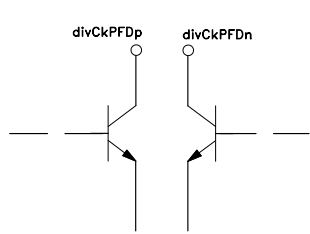
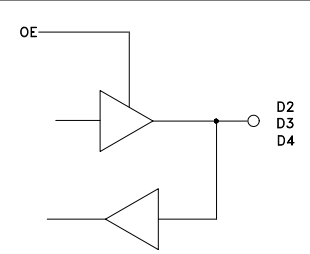
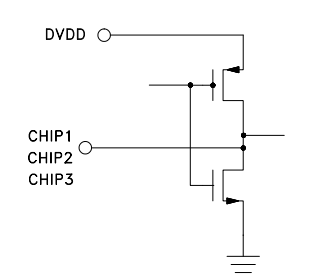
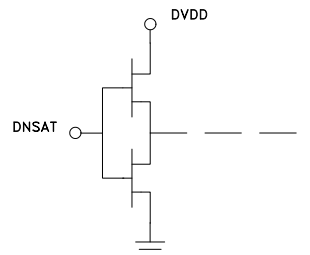

**DC - 7 GHZ FRACTIONAL-N DIVIDER  
AND FREQUENCY SWEEPER**
**Table 2. Pin Descriptions** (Continued)

Pin Number	Function	Description	Interface Schematic
17, 18	divCkPFDn, divCkPFDp	Negative Pin for Open Collector Divider Output Driver Positive Pin for Open Collector Divider Output Driver	
19	VDDM	3V Supply Pin for Digital Section of the Frequency Divider	
20, 21, 22	D2, D3, D4	GPIO bit 2, GPIO bit 3, GPIO bit 4	
23	REF_Eno	Gate Control (Output) to request TCXO Clock Export from HMC984LP4E	
24, 25, 26	CHIP1, CHIP2, CHIP3	Chip Address Pin 1, Chip Address Pin 2, Chip Address Pin 3	
27, 30	DVDD	3V Power Supply for Digital	
28,	DNSAT,	VCO Saturation Input flag from HMC984LP4E Chip	

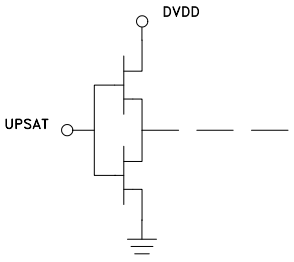
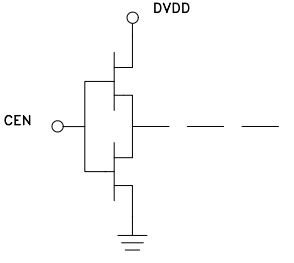
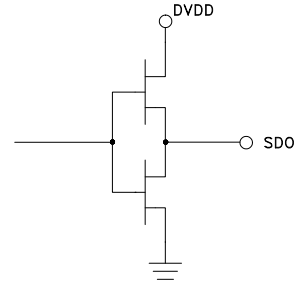

## DC - 7 GHZ FRACTIONAL-N DIVIDER AND FREQUENCY SWEEPER

**Table 2. Pin Descriptions** (Continued)

Pin Number	Function	Description	Interface Schematic
29	UPSAT	Reference Saturation Input flag from HMC984LP4E Chip	
31	CEN	Chip Enable	
32	SDO	Main SPI Data Output	



**DC - 7 GHZ FRACTIONAL-N DIVIDER  
AND FREQUENCY SWEEPER**
**Table 3. Absolute Maximum Ratings**

Nominal 3V Supplies to GND	-0.3 to 3.6 V
Nominal 3V Digital Supply to 3V Analog Supply	-0.3 to +0.3 V
Nominal 5V Supply to GND (VPPBUF)	-0.3 to 5.5 V
divCkp, divCkn common mode DC	VCCPS + 0.5 V min
VCOIP, VCOIN Single Ended AC 50 Ω Source	+ 7 dBm
VCOIP, VCOIN Differential AC 50 Ω Source	+ 13 dBm
Digital Input Voltage Range	-0.25 to DVDD + 0.5 V
Minimum Digital Load	1 kΩ
Operating Temperature Range	-40 °C to +85 °C
Maximum Junction Temperature	125 °C
Storage Temperature	-65 to +125 °C

Thermal Resistance (Rth) (junction to ground paddle)	40 °C/W
Reflow Soldering Peak Temperature Time at Peak Temperature	260 °C 40 s
ESD Sensitivity (HBM)	Class 1B

Stresses above those listed under Absolute Maximum Ratings may cause permanent damage to the device. This is a stress rating only; functional operation of the device at these or any other conditions above those indicated in the operational section of this specification is not implied. Exposure to absolute maximum rating conditions for extended periods may affect device reliability.

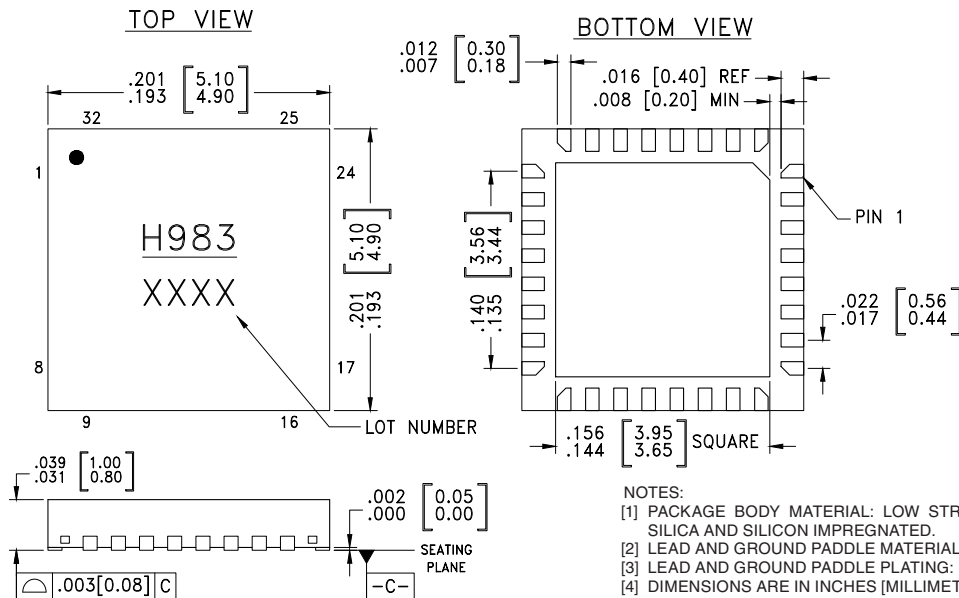

**ELECTROSTATIC SENSITIVE DEVICE  
OBSERVE HANDLING PRECAUTIONS**

**Outline Drawing**

**NOTES:**

- PACKAGE BODY MATERIAL: LOW STRESS INJECTION MOLDED PLASTIC SILICA AND SILICON IMPREGNATED.
- LEAD AND GROUND PADDLE MATERIAL: COPPER ALLOY.
- LEAD AND GROUND PADDLE PLATING: 100% MATTE TIN.
- DIMENSIONS ARE IN INCHES [MILLIMETERS].
- LEAD SPACING TOLERANCE IS NON-CUMULATIVE.
- PAD BURR LENGTH SHALL BE 0.15 mm MAX. PAD BURR HEIGHT SHALL BE 0.25 mm MAX.
- PACKAGE WARP SHALL NOT EXCEED 0.05 mm
- ALL GROUND LEADS AND GROUND PADDLE MUST BE SOLDERED TO PCB RF GROUND.
- REFER TO HITTITE APPLICATION NOTE FOR SUGGESTED PCB LAND PATTERN.

**Package Information**

Part Number	Package Body Material	Lead Finish	MSL Rating <sup>[2]</sup>	Package Marking <sup>[1]</sup>
HMC983LP5E	RoHS-compliant Low Stress Injection Molded Plastic	100% matte Sn	MSL1	H983 XXXX

[1] 4-Digit lot number XXXX

[2] Max peak reflow temperature of 260 °C

For price, delivery and to place orders: Hittite Microwave Corporation, 2 Elizabeth Drive, Chelmsford, MA 01824

978-250-3343 tel • 978-250-3373 fax • Order On-line at [www.hittite.com](http://www.hittite.com)

Application Support: [apps@hittite.com](mailto:apps@hittite.com)



**DC - 7 GHZ FRACTIONAL-N DIVIDER  
AND FREQUENCY SWEEPER**

**Evaluation PCB**

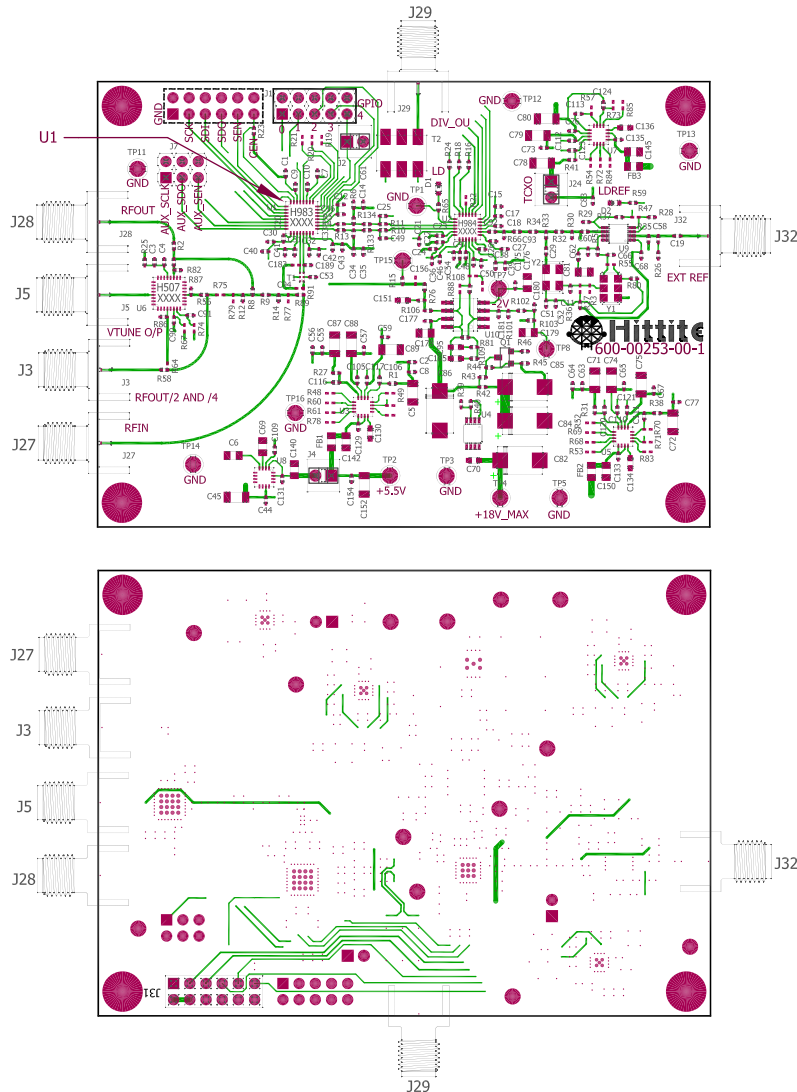

The circuit board used in the application should use RF circuit design techniques. Signal lines should have 50 Ohms impedance while the package ground leads and exposed paddle should be connected directly to the ground plane similar to that shown unless mentioned otherwise. A sufficient number of via holes should be used to connect the top and bottom ground planes. The evaluation circuit board shown is available from Hittite upon request.

**Table 4. Evaluation Order Information**

Item	Contents	Part Number
Evaluation Kit	HMC983LP5E and HMC984LP4E PLL Chipset Evaluation PCB USB Interface Board 6' USB A Male to USB B Female Cable CD ROM (Contains User Manual, Evaluation PCB Schematic, Evaluation Software)	EKIT01-HMC983LP5E

## DC - 7 GHZ FRACTIONAL-N DIVIDER AND FREQUENCY SWEEPER

### Evaluation PCB Block Diagram

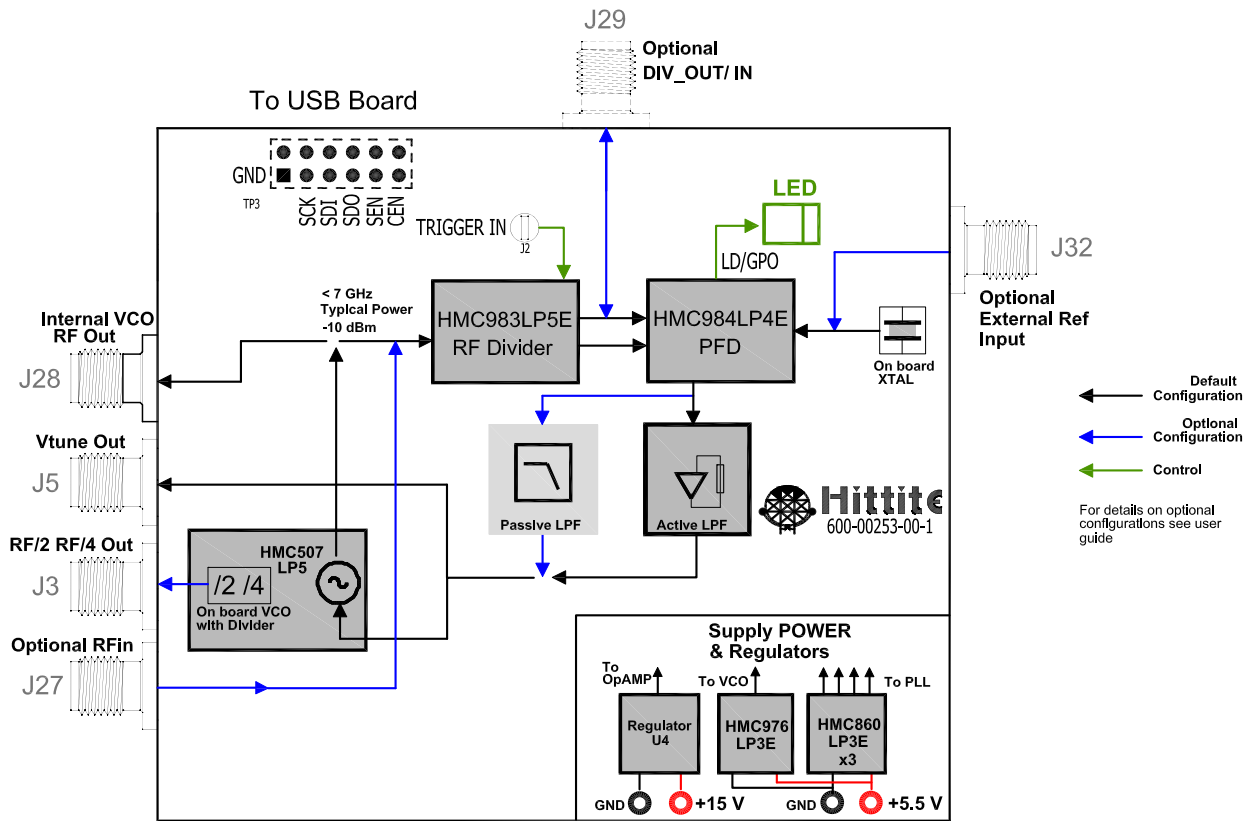



## DC - 7 GHZ FRACTIONAL-N DIVIDER AND FREQUENCY SWEEPER

### Theory of Operation

The HMC983LP5E can be used in following configurations:

1. Fractional-N or Integer Mode RF Frequency Divider or Prescaler
2. Fractional-N Frequency Synthesizer with an appropriate Phase Detector and VCO

Primary target application of the HMC983LP5E is to be used in conjunction with the HMC984LP4E as shown in [Figure 19](#). Together these two components form a high performance, low noise, ultra low spurious emissions fractional-N frequency synthesizer.

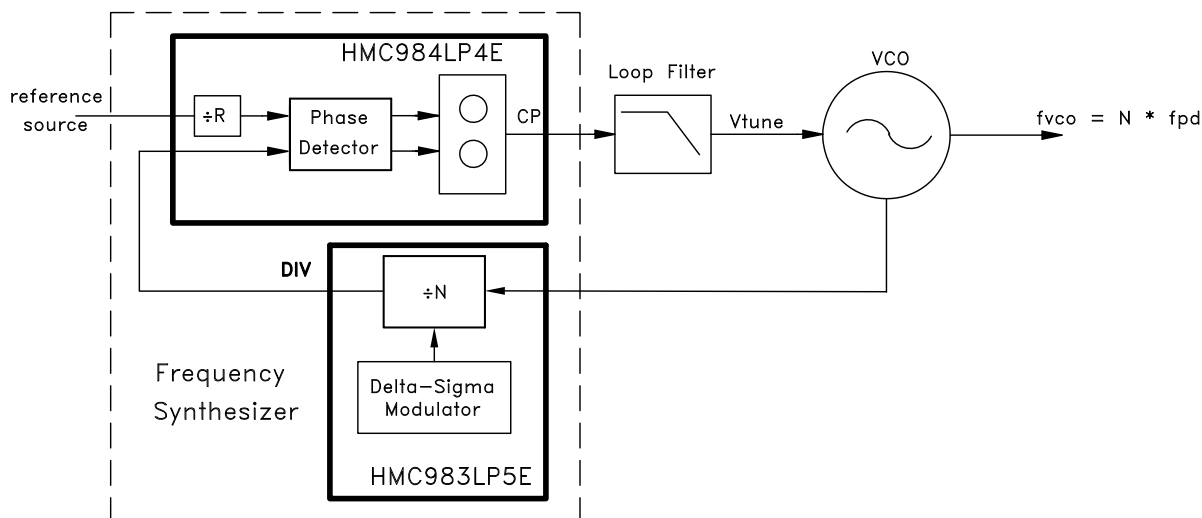

Figure 19. Typical Application of HMC984LP4E with HMC983LP5E to Form a Frequency Synthesizer

The HMC983LP5E consists of the following functional blocks

1. RF Input Buffer
2. 7 GHz Frequency Prescaler and Multi Modulus Divider
3. 48-bit Configurable Fractional Delta Sigma Modulator
4. Bias Circuit
5. Differential Output Driver
6. Frequency Sweeper
7. Main Serial Port Interface
8. Auxiliary Serial Port Interface (Output Only)
9. General Purpose Digital IO
10. Power On Reset Circuit

### RF Input Buffer

The RF input stage provides the path from the external VCO to the fractional RF Divider. The RF input path is rated to operate nominally from DC to 7 GHz. The HMC983LP5E RF input stage is a differential common emitter stage with DC coupling, and is protected by ESD diodes as shown in [Figure 20](#). RF input is not matched to 50  $\Omega$  due to wide input frequency range. At low frequencies, a simple shunt 50  $\Omega$  resistor can be used external to the package to provide a 50  $\Omega$  match. For better performance it is recommended to match the RF inputs externally and provide differential drive from the VCO. In most applications the input is used single-ended into either the VCOIP or VCOIN pin with the other input connected to ground through a DC blocking capacitor. The preferred input level for best spectral performance is -10 dBm.



DC - 7 GHZ FRACTIONAL-N DIVIDER AND FREQUENCY SWEEPER

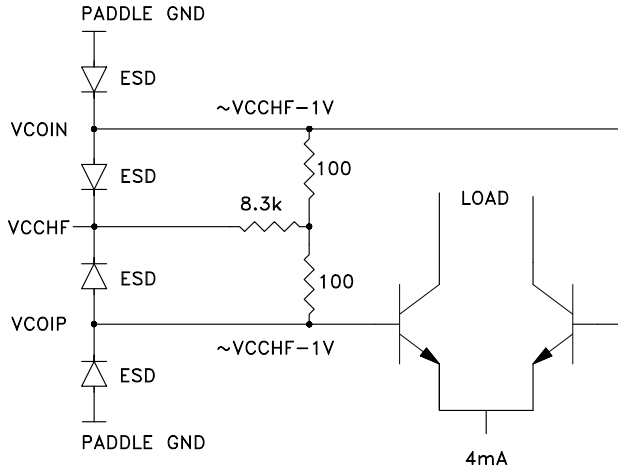

Figure 20. RF Input Stage

RF Path Fractional-N Divider

The RF input buffer is followed by a high frequency prescaler and a multi modulus divider. The divider has been designed for the best output phase noise and spurious performance in both fractional and integer mode. The fractional-N divider can divide input frequencies from 32 to  $2^{20}-1$  (1048575) in integer mode and from 36 to  $2^{20}-5$  (1048571) in fractional-N mode. The divider output pulse width depends on the RF input period and is adjustable via SPI setting (refer to Duty Cycle Setting in register [Reg 0Fh\[14:12\]](#)). The output pulse width recommended setting is 40% to 60% where possible. At low output frequencies it may not be possible to set 50% duty cycle. In such cases the maximum pulse width setting is recommended.

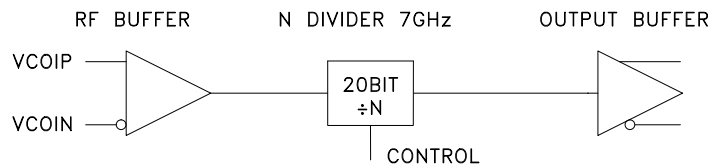

Figure 21. Divider Path

Divider Output Buffer

The divider output is differential and the output buffer stage is an open collector amplifier with off-chip pull-up resistors. Due to sharp rise and fall times at the divider output, the external path should be designed differentially using RF techniques.

When HMC983LP5E and HMC984LP4E are operating together as a frequency synthesizer, 50 Ω pull-up resistors are provided in HMC984LP4E.

VPPBUF pin should be connected to 5 V power supply. This pin does not sink DC current and is only used to bias the internal ESD diodes and to provide an appropriate voltage level for the phase detector chip (HMC984LP4E). The two possible interface configurations are shown in [Figure 22](#) and [Figure 23](#) below.



**DC - 7 GHz FRACTIONAL-N DIVIDER  
AND FREQUENCY SWEEPER**

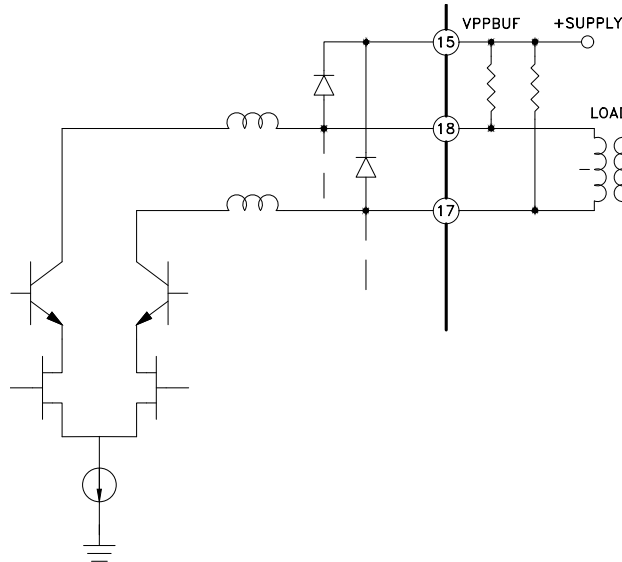

Figure 22. Generic Divider Output Interface

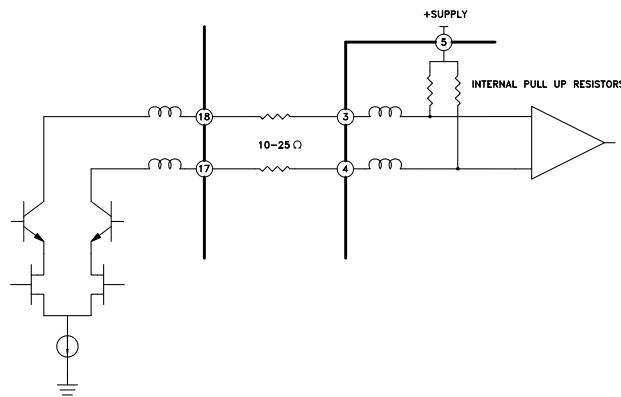

Figure 23. Divider Interface with HMC984LP4E

**Chip Address Pins**

The HMC983LP5E has three SPI chip address pins (SPI address [2:0] = 'CHIP3, CHIP2, CHIP1'), which enable multiple HMC983LP5E devices to use the same SPI bus. SPI chip address bits are read at power up, or every time HMC983LP5E is reset. By default, all three pins are internally pulled to DVDD, thus there is no need to connect the pins to DVDD to set them to logic high. To assign a '0' to any chip address bit, the corresponding pin should be connected to ground.

When used on the same SPI bus together with the companion part (the HMC984LP4E), to form a frequency synthesizer, some SPI commands, such as changing the reference division ratio to the HMC984LP4E may also require an action by the HMC983LP5E. In order to avoid the necessity to write two separate SPI transfers to implement one command (one to configure HMC984LP4E, and the other one to configure the HMC983LP5E), it is possible to write the SPI address of the companion part (HMC984LP4E) into [Reg 09h](#) of the HMC983LP5E. In such cases, the HMC983LP5E is able to recognize an SPI command to the companion part (the HMC984LP4E) that requires its own action, and act accordingly to update its own corresponding registers. Writing HMC983LP5E's own chip address to the companion chip address register [Reg 09h](#) will disable this feature.

### Saturation Detection Input Pins DNSAT, UPSAT

When the HMC983LP5E is operating with its companion chip the HMC984LP4E as a frequency synthesizer, it automatically detects large phase errors and tries to tune the VCO faster by using its algorithm for cycle-slip prevention (CSP). The UPSAT and DNSAT provide indication which frequency is higher (VCO or Reference) from the counterpart Phase Detector/Charge Pump (the HMC984LP4E). The CSP algorithm manipulates the RF Divider and the Phase Detector at appropriate intervals to lock faster. See HMC984LP4E data sheet for more details. These pins should be connected to ground if not used.

### REF\_Eno Pin

REF\_Eno pin is a digital output pin that is used by the HMC983LP5E to request crystal oscillator clock from the Phase Detector / Charge Pump chip (the HMC984LP4E).

The crystal oscillator clock is multiplexed on the HMC983LP5E's DNSAT pin. The internal frequency divider, programmed in [Reg 02h](#), is used to generate the actual reference frequency present at the phase detector. The imported clock is only used to communicate through the AUXSPI. At all other times, the clock and the local reference dividers are turned off.

In stand-alone applications, if the HMC983LP5E is required to communicate through the auxiliary SPI, the HMC983LP5E will expect to receive the auxiliary SPI clock on DNSAT pin. Setting [Reg 04h](#)[15] = 1 keeps the auxiliary SPI clock enabled on the DNSAT pin.

### Multi Purpose Digital IO Pins D0, D1, D2, D3, D4 (GPIO Pins)

The five general purpose digital input/outputs can be used for various modes of operation as well as test/debugging purposes. GPIO pins are enabled by writing [Reg 01h](#)[4] = 1 (GPIO master enable). Setting [Reg 01h](#)[4] = 0 places the GPIO pins in tri-state high impedance mode.

GPIO pins are configured in [Reg 08h](#)[13:0]. All of the pins can be configured to be either inputs or outputs by writing to [Reg 08h](#)[13:9]. In frequency sweep mode, pin D4 can be used as an external trigger pin, by writing [Reg 08h](#)[13] = 0.

Writing to [Reg 08h](#)[3:0] selects HMC983LP5E's internal signals to be multiplexed out on the GPIO pins, as shown in [Table 5](#). Signals include:

1. The output of the Delta-Sigma Modulator [Reg 08h](#)[3:0] = '0010'b.
2. GPIO test signals [Reg 08h](#)[3:0] = '0000'b, which outputs data written to [Reg 08h](#)[8:4] to test the GPIO pins.
3. Sweep status flags, when the HMC983LP5E is configured to be in sweep mode [Reg 08h](#)[3:0] = '1000'b.

**Table 5. GPIO Pin Assignment and Output Signals**

<a href="#">Reg 08h</a> [3:0]	HMC983LP5E GPIO Pins				
	D4	D3	D2	D1	D0
0000	gpo_test_out[4]	gpo_test_out[3]	gpo_test_out[2]	gpo_test_out[1]	gpo_test_out[0]
0001	reserved	reserved	reserved	reserved	reserved
0010	DSM_OUT[4]	DSM_OUT[3]	DSM_OUT[2]	DSM_OUT[1]	DSM_OUT[0]
0011	reserved	reserved	reserved	reserved	reserved
0100	reserved	reserved	reserved	reserved	reserved
0101	reserved	reserved	reserved	reserved	reserved
0110	reserved	reserved	reserved	0	0
0111	reserved	reserved	reserved	reserved	reserved
1000	ramp_ready_flag	ramp_start_flag	ramp_stop_flag	ramp_busy_falg	reserved
1001-1111	0	0	0	0	0





## DC - 7 GHZ FRACTIONAL-N DIVIDER AND FREQUENCY SWEEPER

### Fractional Mode of Operation

In addition to providing simple integer division ratios, the HMC983LP5E has a sophisticated, configurable 48-bit Delta Sigma Modulator (DSM), that allows fractional division of the input frequency in ultra fine steps. The DSM's size can be configured to 16/24/32/48 bits ([Reg 16h](#)[5:0]). HMC983LP5E's auto-seed mode allows coherent frequency sweeps.

The HMC983LP5E with its counterpart (the HMC984LP4E), together with an external VCO comprise a fully functional fractional-N synthesizer. In that case, the output frequency of the external VCO is given by:

$$f_{vco} = \frac{f_{xtal}}{R} \cdot N_{int} + \frac{f_{xtal}}{R \cdot 2^L} \cdot N_{frac} = f_{int} + f_{frac} \quad (\text{Eq 1})$$

When the HMC983LP5E is being used as frequency divider, the output frequency is given by;

$$f_{out} = \frac{f_{vco}}{N_{int} + \frac{N_{frac}}{2^L}} \quad (\text{Eq 2})$$

Where

$f_{vco}$  is the VCO frequency in Hz;

$f_{xtal}$  is the crystal oscillator frequency in Hz;

$N_{int}$  is the integer part of frequency division ratio (set in [Reg 05h](#)[19:0]);

$N_{frac}$  is the fractional part of frequency division ratio ( $N_{frac}$ [47:18] = [Reg 06h](#)[29:0],  $N_{frac}$ [17:0] = [Reg 07h](#)[17:0])

R is the reference frequency division ratio;

L is the size of the DSM accumulators (set in [Reg 16h](#)[5:0])

**Example 1:** Calculate the VCO frequency with the following parameters;

$$\begin{aligned} f_{xtal} &= 50 \text{ MHz}; & f_{pld} &= 25 \text{ MHz} \\ N_{int} &= 25; & N_{frac} &= 1; & L &= 24 \end{aligned}$$

Where  $f_{PFD}$  is the frequency at the phase detector, thus  $R = 2$ . According to ([Eq 1](#)), the VCO frequency with the above parameters will be;

$$f_{vco} = \frac{50\text{MHz}}{2} \cdot 25 + \frac{50\text{MHz}}{2 \cdot 2^{24}} \cdot 1 = 2500\text{MHz} + 1.49\text{Hz}$$

If accumulator width (L) is changed to 48-bit, then the frequency resolution will improve and the fractional resolution of the VCO frequency will be 88.8178 nano-Hz.

**Example 2:** Set the VCO frequency to 4600.025 MHz using 100 MHz Crystal,  $R = 2$  and  $L = 16$ . Compare if  $L = 32$ .

For this example the  $f_{PFD} = 100 \text{ MHz}/2 = 50 \text{ MHz}$ ,

The overall division ratio is  $4600.025 \text{ MHz}/50 \text{ MHz} = 92.0005$

The nearest integer would be 92, thus  $N_{int} = \text{Reg 05h}[19:0] = 92d = 5\text{Ch}$ .

For  $L = 16$ ,  $N_{frac} = 32.768$  or 33d rounded up. Thus  $N_{frac} = 33d$  or 21h ([Reg 06h](#)[29:0] = 0, [Reg 07h](#)[17:0] = 21h).

For  $L = 32$ ,  $N_{frac} = 2147483.648$  or 2147484d rounded up. Thus  $N_{frac} = 20\text{C}49\text{Ch}$  ([Reg 06h](#)[29:0] = 8h, [Reg 07h](#)[17:0] = '001100010010011100'd).

Since  $N_{frac}$  must be an integer, the actual frequencies in the two cases will have an error of + 177.02 Hz for  $L = 16$  and only +0.004098 Hz for  $L = 32$ .



**DC - 7 GHZ FRACTIONAL-N DIVIDER  
AND FREQUENCY SWEEPER****Phase Noise in Integer and Fractional Modes**

In a normal integer frequency divider the in-band phase noise is scaled from the input phase noise by  $20\log_{10}(N)$ , where  $N$  is the divider value. In HMC983LP5E fractional mode, the frequency divider is modulated by the Delta Sigma Modulator to generate output frequencies that are fractional multiple of the input frequency. Delta Sigma Modulator shapes the quantization noise such that quantization noise density has a high pass shape which peaks at  $F_s/2$ , where  $F_s$  is the sampling frequency (the divider output frequency in case of HMC983LP5E). In fractional mode this quantization noise peak appears at an offset frequency of  $F_{out}/2$ . In the PLL, this peak is attenuated by the loop filter. However, when the HMC983LP5E is used stand-alone in fractional mode its output will exhibit the quantization noise as shown in [Figure 2](#) and [Figure 3](#). As a result, it is not possible to achieve the same noise floor in fractional mode as in integer mode without further filtering.

**CW Frequency Sweeper**

The HMC983LP5E features a built-in frequency sweeper function that supports automatic or externally triggered sweeps. External triggering can be executed via an external trigger pin D4 or the SPI interface.

HMC983LP5E sweep function can be configured to operate in the following modes:

- 2-Way sweep mode
  - Repeating alternating positive and negative frequency sweep ramps
  - Frequency increments swept with automatic sequencer
  - Automatic or triggered
  - Symmetric or asymmetric (the positive ramp can have a different slope from that of the negative ramp)
- 1-Way Sweep Mode
  - Repeating one directional frequency sweeps followed by a reset to the starting frequency
  - Frequency increments swept with automatic sequencer
  - Triggered

User defined sweep mode

- Manually programmed user defined sweep patterns
- Triggered
- Symmetric or asymmetric (the positive ramp can have a different slope from that of the negative ramp)

In all sweep modes, the starting sweep direction can be set to positive (increasing) or negative (decreasing). The trigger can be applied instantaneously or delayed by a programmable time delay.

HMC983LP5E's sweep function is illustrated in [Figure 24](#). The HMC983LP5E generates a frequency sweep by implementing automatic, or triggered in User Defined Mode, discrete miniature frequency increments in time. A smooth and continuous sweep is then generated, at the output of the VCO, after the stepped signal is filtered by the loop filter, as shown in [Figure 24](#). The stepped sweep approach enables the frequency synthesizer (comprising of HMC983LP5E together with its counterpart, the HMC984LP4E) to be in lock for the entire duration of the sweep. This approach results in a number of advantages over conventional methods including:

- The ability to generate a linear sweep.
- The ability to have phase coherence between different sweep ramps, so that the phase profile of each sweep is identical.
- The ability to generate user defined sweeps in User Defined Sweep Mode.



## DC - 7 GHZ FRACTIONAL-N DIVIDER AND FREQUENCY SWEEPER

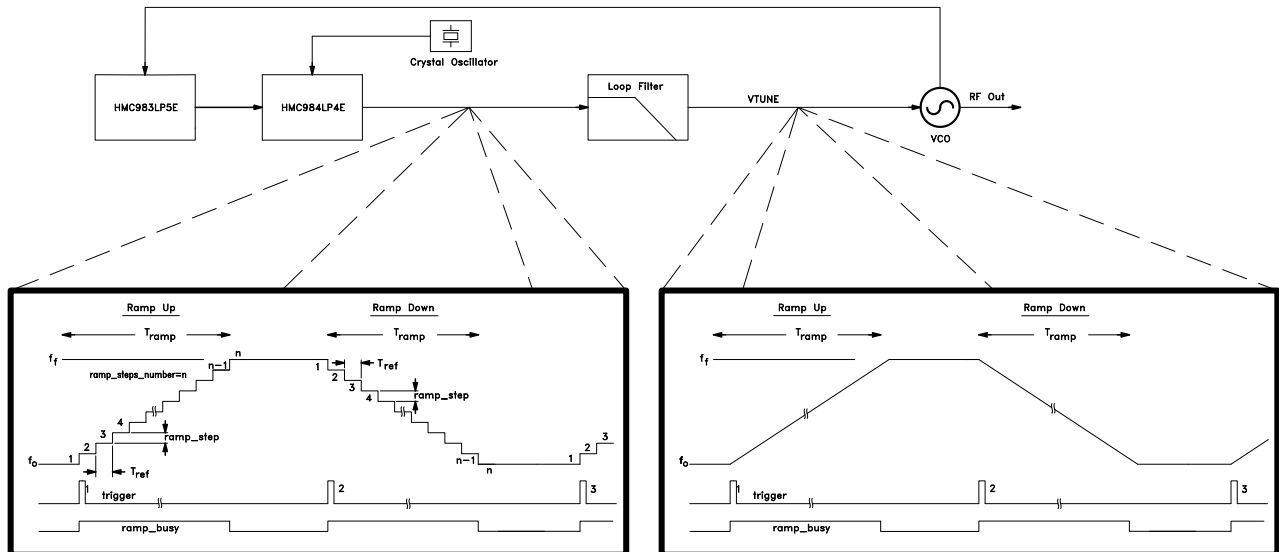

Figure 24. HMC983LP5E Sweep Function

It is important to note that the synthesized ramp is subject to normal phase locked loop dynamics. If the loop bandwidth in use is much wider than the rate of frequency increments then the locking will be fast and the ramp will have a staircase shape. If the update rate is higher than the loop bandwidth, as is normally the case, the loop will not fully settle before a new frequency step is received. Hence the swept output will have a lag and will sweep in a near continuous fashion.

In all sweep modes, ramp\_busy flag indicates an active sweep and will stay high between the 1st and nth ramp increment. ramp\_busy may be monitored on pin D1 by setting [Reg 08h\[3:0\] = 8h](#).

### Triggering

In sweep mode, the HMC983LP5E can be triggered via one of two methods

- SPI trigger by setting [Reg 0Eh\[12\]=1](#). This triggering method is asynchronous to the reference clock. To enable SPI trigger write [Reg 0Eh\[13\] = 0](#).
- or applying an external trigger on pin D4. Setting [Reg 0Eh\[13\] = 1](#) and [Reg 08h\[13\] = 0h](#) configures HMC983LP5E's pin D4 as external trigger input. External trigger on pin D4 is triggered on the rising edge of the trigger. GPIO master enable ([Reg 01h\[4\] = 1](#)) is also required.
  - External triggering method can be synchronized with the reference clock, by enabling trigger delay ([Reg 0Eh \[7\] = 1](#)), and programming a trigger delay in [Reg 05h\[20:0\] = number of delayed reference periods](#). Writing [Reg 05h\[20:0\] = 1](#) for example ensures that the trigger is applied at the instant of the rising edge of the next reference rising edge. To disable trigger delay write [Reg 0Eh \[7\] = 0](#).

### 2-Way Sweep Mode

HMC983LP5E's 2-Way sweep mode is shown in [Figure 25](#). The 2-Way sweep mode can be automatic or triggered. In automatic 2-way sweep, the trigger is generated internally based on user defined 2-way sweep mode configuration. In a triggered 2-way sweep, frequency ramps are triggered either by external pin D4, or SPI trigger.

## DC - 7 GHZ FRACTIONAL-N DIVIDER AND FREQUENCY SWEEPER

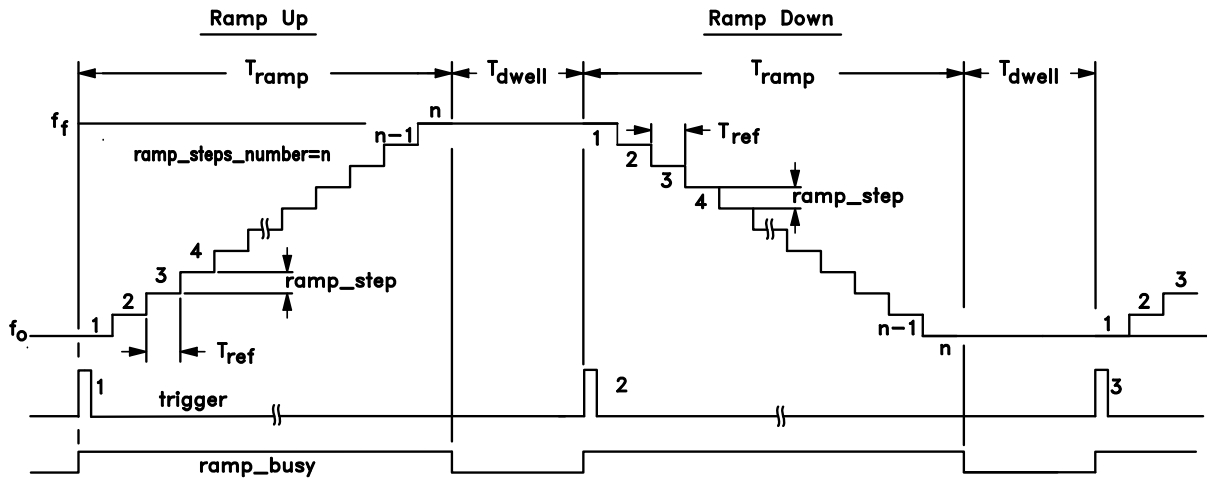

Figure 25. HMC983LP5E 2-Way Triggered Sweep

### Triggered 1-Way Sweeps

HMC983LP5E's 1-Way sweeps is shown in [Figure 26](#). Unlike 2-Way sweeps, 1-Way sweeps require that the VCO hop back to the start frequency after the dwell period. Triggered 1-Way sweeps also require a 3rd trigger to start the new sweep. The 3rd trigger must be timed appropriately to allow the VCO to settle after the large frequency hop back to the start frequency. Subsequent odd numbered triggers will start each sweep and repeat the process.

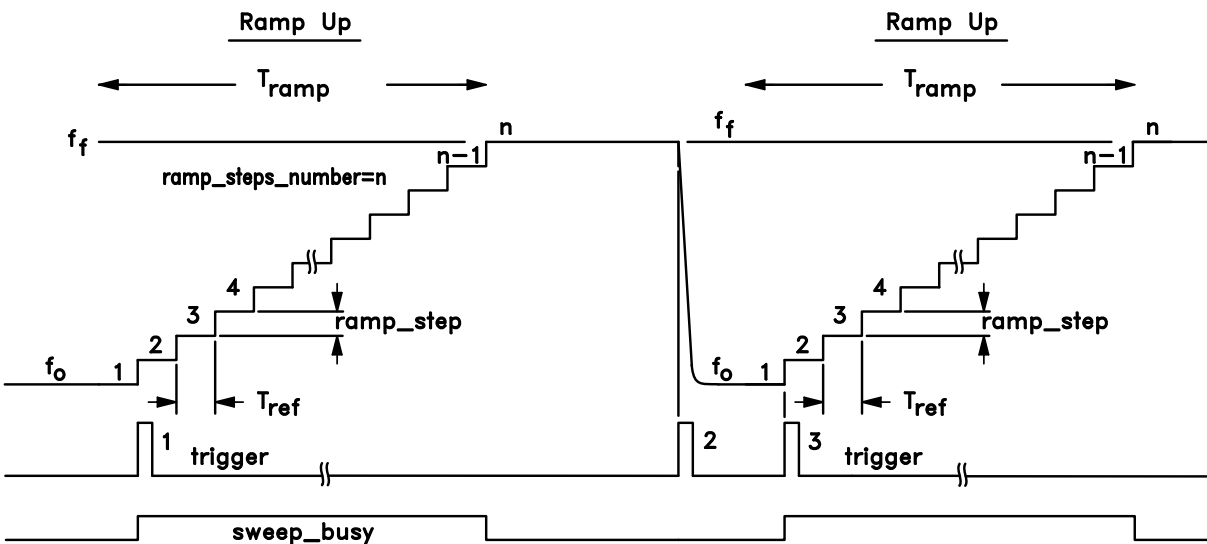

Figure 26. HMC983LP5E 1-Way Triggered Sweep

1-Way sweeps are not recommended in auto-sweep mode since in auto-sweep the new sweep will start immediately after the 2nd trigger, as it does in 2-Way mode.

### User Defined Sweep Mode

In User Defined Sweep mode, the HMC983LP5E is able to generate various user-defined sweep patterns by adjusting the time interval between adjacent frequency increments, which are executed by trigger events. HMC983LP5E's User Defined Sweep Mode is shown in [Figure 27](#). In this mode, an external trigger is required for each frequency increment of the sweep.

## DC - 7 GHZ FRACTIONAL-N DIVIDER AND FREQUENCY SWEEPER

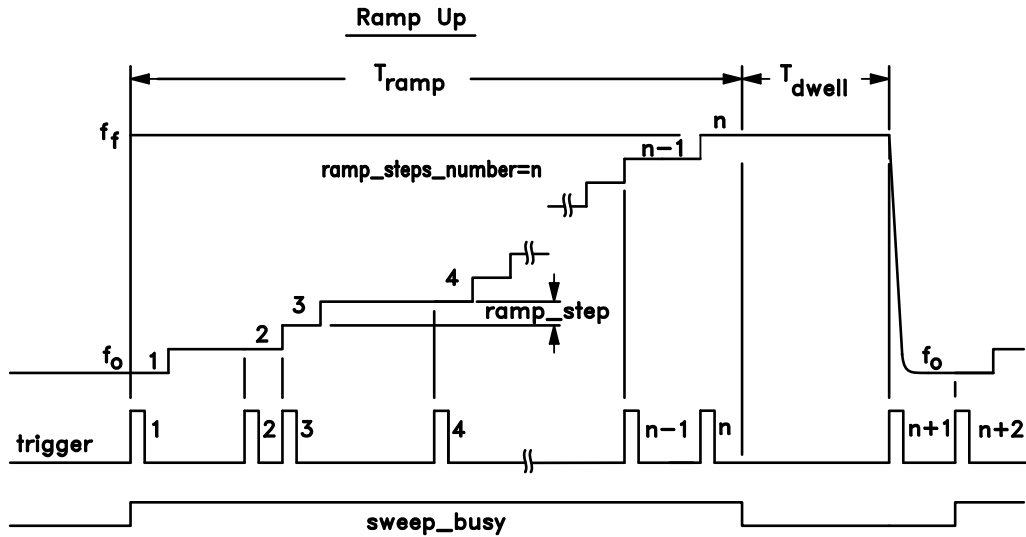

Figure 27. HMC983LP5E User Defined Sweep

User defined sweep can function in both 1-Way or 2-Way sweep mode. In 1-Way sweep mode, the n+1 trigger will cause the ramp to jump to the start frequency, and the n+2 trigger will restart the 1-way sweep.

### Detailed Sweeper Configuration

Recommended procedure for configuring HMC983LP5E sweeper in all three modes is shown in [Table 6](#).

**DC - 7 GHZ FRACTIONAL-N DIVIDER  
AND FREQUENCY SWEEPER**
**Table 6. HMC983LP5E Sweeper Configuration Sequence**

Steps	Description	Sweeper Modes		
		2-Way Sweep Mode	User Defined Sweep Mode	1-Way Sweep Mode
1	Lock to start frequency ( $f_o$ )	<ul style="list-style-type: none"> <li>set the integer (<a href="#">Reg 05h</a>) and fractional (<a href="#">Reg 06h</a> and <a href="#">Reg 07h</a>) divider values.</li> <li>Optionally, if required the seed (<a href="#">Reg 0Ah</a> and <a href="#">Reg 0Bh</a>) can also be programmed</li> </ul>		
2	Place the DSM in sweep mode	<ul style="list-style-type: none"> <li>Write <a href="#">Reg 0Eh[11]</a> = 1</li> </ul>		
3	Configure sweep mode	<ul style="list-style-type: none"> <li>Disable single step ramp mode (<a href="#">Reg 0Eh[24]</a> = 0), so that each frequency increment will be incremented automatically</li> <li>Enable 2-way sweep mode (Disable 1-way sweep mode (<a href="#">Reg 0Eh[25]</a> = 0))</li> <li>To place the HMC983LP5E in automatic sweep mode write <a href="#">Reg 0Eh[2:3]</a> = '11'. To place the HMC983LP5E in triggered mode write <a href="#">Reg 0Eh[2:3]</a> = '00'.</li> </ul>	<ul style="list-style-type: none"> <li>Enable the single step ramp mode (<a href="#">Reg 0Eh[24]</a> = 1), so that each frequency increment will require a trigger</li> <li>Enable 1-way sweep mode (<a href="#">Reg 0Eh[25]</a> = 1), or enable 2-Way sweep mode (<a href="#">Reg 0Eh[25]</a> = 1)</li> <li>To place the HMC983LP5E in triggered mode write <a href="#">Reg 0Eh[2:3]</a> = '00'. Automatic User Defined Sweep mode is not supported.</li> </ul>	<ul style="list-style-type: none"> <li>Disable single step ramp mode (<a href="#">Reg 0Eh[24]</a> = 0), so that each frequency increment will be incremented automatically</li> <li>Enable 1-way sweep mode (<a href="#">Reg 0Eh[25]</a> = 1)</li> <li>To place the HMC983LP5E in triggered mode write <a href="#">Reg 0Eh[2:3]</a> = '00'. Automatic 1-Way Sweep mode is not supported.</li> </ul>
4	Program Sweep Direction	<ul style="list-style-type: none"> <li><a href="#">Reg 0Eh[26]</a> = 1 begin sweep in positive direction, <a href="#">Reg 0Eh[26]</a> = 0 begin sweep in negative direction</li> </ul>		
5	Configure symmetrical/asymmetrical sweep	<ul style="list-style-type: none"> <li>Program ramp mode (symmetrical - <a href="#">Reg 0Eh[22]</a> = 1, asymmetrical - <a href="#">Reg 0Eh[22]</a> = 0). If symmetrical ramp mode is selected (<a href="#">Reg 0Eh[22]</a> = 1), only Up sweep parameters will be used for both positive and negative sweeps, and hence down sweep parameters don't need to be programmed. In symmetrical ramp mode the positive and negative ramps are identical and opposite in direction.</li> </ul>		<ul style="list-style-type: none"> <li>Program <a href="#">Reg 0Eh[22]</a> = 1. Asymmetrical sweep is not defined in 1-Way Sweep mode</li> </ul>
6	Program Up Sweep Parameters	<ul style="list-style-type: none"> <li>Set dwell time(dwll time[47:0] = <a href="#">Reg 10h[29:0]</a>, dwell time[17:0] = <a href="#">Reg 11h[17:0]</a>)</li> <li>Set step size (step size[47:18] = <a href="#">Reg 12h[29:0]</a>, step size[17:0] = <a href="#">Reg 13h[17:0]</a>)</li> <li>Set the number of steps in a sweep (number of steps[47:18] = <a href="#">Reg 14h[29:0]</a>, number of steps[17:0] = <a href="#">Reg 15h[17:0]</a>)</li> </ul>		
7	Program Down Sweep Parameters (Only if using asymmetrical sweep (if <a href="#">Reg 0Eh[22]</a> = 0) in Step 5)	<ul style="list-style-type: none"> <li>Set dwell time (dwell time[47:0] = <a href="#">Reg 06h[47:18]</a>, dwell time[17:0] = <a href="#">Reg 07h[17:0]</a>)</li> <li>Set step size (step size[47:18] = <a href="#">Reg 19h[29:0]</a>, step size[17:0] = <a href="#">Reg 1Ah[17:0]</a>)</li> <li>Set the number of steps in a sweep (number of steps[47:18] = <a href="#">Reg 0Ch[29:0]</a>, number of steps[17:0] = <a href="#">Reg 0Dh[17:0]</a>)</li> </ul>		<ul style="list-style-type: none"> <li>Asymmetrical sweep is not defined in 1-Way Sweep mode</li> </ul>
8	Configure and apply trigger	<ul style="list-style-type: none"> <li>To use SPI trigger write <a href="#">Reg 0Eh[13]</a> = 0 to select SPI trigger. SPI trigger is executed by writing to <a href="#">Reg 0Eh[12]</a> = 1.</li> <li>To use external trigger on pin D4 write <a href="#">Reg 0Eh[13]</a> = 1 to configure pin D4 as an external trigger. Write <a href="#">Reg 08h[13]</a> = 0h to configure pin D4 to be an input. Applying master enable to GPIO pins (<a href="#">Reg 01h[4]</a> = 1) is required.                             <ul style="list-style-type: none"> <li>Enable trigger delay (<a href="#">Reg 0Eh[7]</a> = 1), or disable trigger delay (<a href="#">Reg 0Eh[7]</a> = 0).</li> <li>If using trigger delay, write delay value to <a href="#">Reg 05h[20:0]</a>, where <a href="#">Reg 05h[20:0]</a> = number of delayed reference periods. Writing <a href="#">Reg 05h[20:0]</a> = 1 for example ensures that the trigger is applied at the instant of the rising edge of the next reference rising edge.</li> </ul> </li> </ul>		

HMC983LP5E sweep parameters are defined in the following way:

 $f_o$  Initial frequency of the synthesizer



## DC - 7 GHZ FRACTIONAL-N DIVIDER AND FREQUENCY SWEEPER

$f_f$	Frequency of the synthesizer at the end of the sweep
R	Reference divider value(Reg 02h[13:0])
stepsize	frequency increment step size. In case of symmetric and UP sweeps, stepsize[47:18] = Reg 12h[29:0], stepsize[17:0] = Reg 13h[17:0]. In case of asymmetric sweeps, (downsweep stepsize[47:18] = Reg 12h[29:0], down sweep stepsize[17:0] = Reg 13h[17:0])
$\Delta f_{step}$	Frequency step size = $stepsize \cdot \frac{f_{xtal}}{2^L \cdot R}$
L	Size of the DSM (set in Reg 16h[5:0])
$T_{ref}$	Period of the divided reference ( $f_{PFD}$ ) at the phase detector. $T_{ref} = \frac{R}{f_{xtal}}$
N	Total number of frequency step increments in a single sweep. N [47:18] = Reg 14h[29:0], N[17:0] = Reg 15h[17:0]
$T_{ramp}$	Total time of one frequency sweep from $f_o$ to $f_f$ . $T_{ramp} = T_{ref} \times N$

Then final frequency  $f_f$  is given by:  $f_f = f_o + (\Delta f_{step} \times N)$

Setting autoseed (Reg 0Eh[8] = 1) ensures that different sweeps have identical phase profile. This is achieved by loading the seed (seed[47:18] = Reg 0Ah[29:0], seed[17:0] = Reg 0Bh[17:0]) into the phase accumulator at the beginning of each ramp.

*Example: Calculate sweep parameters for an asymmetric 2-Way sweep from  $f_o = 3000$  MHz to  $f_f = 3105$  MHz with positive  $T_{ramp} \approx 2$  ms, and negative  $T_{ramp} \approx 4$  ms, and positive dwell time = negative dwell time = 2  $\mu$ s, with  $f_{PD} = 50$  MHz, and a 48-bit delta-sigma modulator size. Assuming  $R = 1$ .*

- Calculate the integer and fractional divider values for initial start frequency  $f_o$ 
  - Start Nint = Reg 05h = 60d
  - Start Nfrac = Reg 06h = Reg 07h = 0d
- Calculate the number of divided ( $R = 1$ ) reference periods in the sweep = number of frequency increments N
  - $N_{up} = 2 \text{ ms} / (1/50 \text{ MHz}) = 100000$
  - $N_{down} = 4 \text{ ms} / (1/50 \text{ MHz}) = 200000$
- Calculate stepsize (size of frequency increments)
  - stepsize up =  $abs(f_f - f_o) / N_{up} = abs(3000 \text{ MHz} - 3105 \text{ MHz}) / 100000 = 1050 \text{ Hz}$ . Then as per Table 6, Reg 12h[29:0] = 0h, Reg 13h[17:0] = 1050d = 41Ah
  - stepsize down =  $abs(f_o - f_f) / N_{down} = abs(3000 \text{ MHz} - 3105 \text{ MHz}) / 200000 = 525 \text{ Hz}$  Then as per Table 6, Reg 19h[29:0] = 0h, Reg 1Ah[17:0] = 1050d = 41Ah

Note that it is possible to have a case where the frequency  $f_f$  cannot be generated exactly. In that case it is required to approximate the final frequency to  $f_f = f_o + (\Delta f_{step} \times N) \approx$  desired final frequency.
- Calculate number of divided ( $R = 1$ ) reference periods in required dwell time
  - Up dwell time (Reg 10h[29:0], Reg 11h[17:0]) = down dwell time (Reg 06h[29:0], Reg 07h[17:0]) = dwell time / (1/ 50 MHz) = 2  $\mu$ s / (1/50 MHz) = 100. Then as per Table 6, Reg 10h[29:0] = Reg 06h[29:0] = 0h, and Reg 11h[17:0] = Reg 07h[17:0] = 100d = 64h.

Then proceed to configure the sweep according to the steps outlined in Table 6.

### Serial Port Interface

The HMC983LP5E features a four wire serial port for simple communication with the host controller. Typical serial port operation can be run with SCK at speeds up to 30 MHz.



**DC - 7 GHZ FRACTIONAL-N DIVIDER  
AND FREQUENCY SWEEPER**

The details of SPI access for the HMC983LP5E is provided in the following sections. Note that the READ operation below is always preceded by a WRITE operation to Register 0 to define the register to be queried. Also note that every READ cycle is also a WRITE cycle in that data sent to the SPI while reading the data will also be stored by the HMC983LP5E when SENb goes high. If this is not desired then it is suggested to write to Register 0 during the READ operation so that the status of the device will be unaffected.

**Power on Reset and Soft Reset**

The HMC983LP5E has a built in Power On Reset (POR) and a serial port accessible Soft Reset (SR). POR is accomplished when power is cycled for the HMC983LP5E while SR is accomplished via the SPI by writing [Reg 00h](#) = 80h, followed by writing [Reg 00h](#) = 00h. All chip registers will be reset to default states approximately 250 us after power up.

**Serial Port WRITE Operation**

The host changes the data on the falling edge of SCK and the HMC983LP5E reads the data on the rising edge.

A typical WRITE cycle is shown in [Figure 28](#). It is 32 clock cycles long.

1. The host both asserts SENb (active low Serial Port Enable) and places the MSB of the data on SDI followed by a rising edge on SCK.
2. HMC983LP5E reads SDI (the MSB) on the 1st rising edge of SCK after SENb.
3. HMC983LP5E registers the data bits, D23:D0, in the next 23 rising edges of SCK (total of 24 data bits).
4. Host places the 5 register address bits, A4:A0, on the next 5 falling edges of SCK (MSB to LSB) while the HMC983LP5E reads the address bits on the corresponding rising edge of SCK.
5. Host places the 3 chip address bits, CA2:CA0=[110], on the next 3 falling edges of SCK (MSB to LSB). Note the HMC983LP5E chip address is fixed as "6d" or "110b".
6. SENb goes from low to high after the 32nd rising edge of SCK. This completes the WRITE cycle.
7. HMC983LP5E also exports data back on the SDO line. For details see the section on READ operation.

**Serial Port READ Operation**

The SPI can read from the internal registers in the chip. The data is available on SDO pin. This pin itself is tri-stated when the device is not being addressed. However when the device is active and has been addressed by the SPI master, the HMC983LP5E controls the SDO pin and exports data on this pin during the next SPI cycle.

HMC983LP5E changes the data to the host on the rising edge of SCK and the host reads the data from HMC983LP5E on the falling edge.

A typical READ cycle is shown in [Figure 28](#). Read cycle is 32 clock cycles long. To specifically read a register, **the address of that register must be written to dedicated Reg 0h**. This requires two full cycles, one to write the required address, and a 2nd to retrieve the data. A read cycle can then be initiated as follows;

1. The host asserts SENb (active low Serial Port Enable) followed by a rising edge SCK.
2. HMC983LP5E reads SDI (the MSB) on the 1<sup>st</sup> rising edge of SCK after SENb.
3. HMC983LP5E registers the data bits in the next 23 rising edges of SCK (total of 24 data bits). **The LSBs of the data bits represent the address of the register that is intended to be read.**
4. Host places the 5 register address bits on the next 5 falling edges of SCK (MSB to LSB) while the HMC983LP5E reads the address bits on the corresponding rising edge of SCK. **For a read operation this is "00000".**
5. Host places the 3 chip address bits [110] on the next 3 falling edges of SCK (MSB to LSB).
6. SENb goes from low to high after the 32<sup>nd</sup> rising edge of SCK. This completes the first portion of the READ cycle.

## DC - 7 GHZ FRACTIONAL-N DIVIDER AND FREQUENCY SWEEPER

7. The host asserts SENb (active low Serial Port Enable) followed by a rising edge SCK.
8. HMC983LP5E places the 24 data bits, 5 address bits, and 3 chip id bits, on the SDO, on each rising edge of the SCK, commencing with the first rising edge beginning with MSB.
9. The host de-asserts SENb (i.e. sets SENb high) after reading the 32 bits from the SDO output. The 32 bits consists of 24 data bits, 5 address bits, and the 3 chip id bits. This completes the read cycle.

Note that the data sent to the HMC983LP5E SPI during this portion of the READ operation is stored in the SPI when SENb is de-asserted. It is recommended that during the second phase of the READ operation that [Reg 00h](#) is addressed with either the same address or the address of another register to be read during the next cycle.

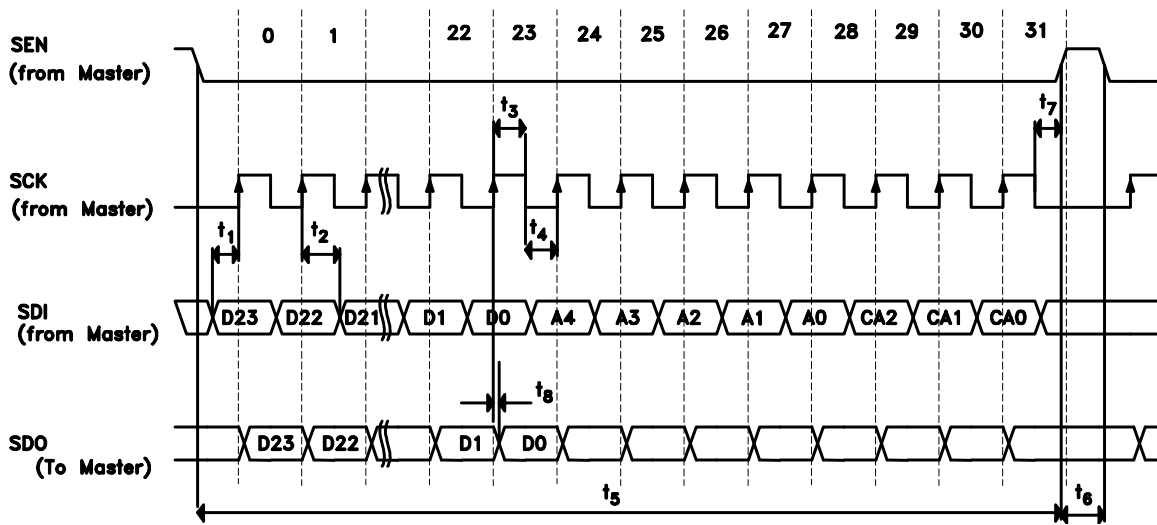

Figure 28. SPI Timing Diagram

DVDD = 5 V ±10%, GND = 0 V

**Table 7. Main SPI Timing Characteristics**

Parameter	Conditions	Min	Typ	Max	Units
t <sub>1</sub>	SDI to SCK Setup Time	8			nsec
t <sub>2</sub>	SDI to SCK Hold Time	8			nsec
t <sub>3</sub>	SCK High Duration [1]	10			nsec
t <sub>4</sub>	SCK Low Duration	10			nsec
t <sub>5</sub>	SENb Low Duration	20			nsec
t <sub>6</sub>	SENb High Duration	20			nsec
t <sub>7</sub>	SCK to SENb [2]	8			nsec
t <sub>8</sub>	SCK to SDO out [3]			8	nsec

[1] The SPI is relatively insensitive to the duty cycle of SCK.

[2] SENb must rise after the 32<sup>nd</sup> falling edge of SCK but before the next rising SCK edge. If SCK is shared amongst several devices this timing must be respected.

[3] Typical load to SDO is 10 pF, maximum 20 pF



**DC - 7 GHZ FRACTIONAL-N DIVIDER  
AND FREQUENCY SWEEPER**
**Register Map**
**Table 8. Reg 00h Chip ID, Soft Reset, Read Register**

BIT	TYPE	NAME	W	DEFLT	DESCRIPTION
[6:0]	R/W	Read Register Address	7	0	Address of the register to be read in the next cycle.
[7]	R/W	Soft Reset	1	0	Soft Reset. Writing 1 generates soft reset. Resets all the digital and registers to default states. Writing 0 resumes normal chip operation.
[31:8]	R/W	Chip ID	24	97330h	Part Number, Description. Read reg00h returns chip ID.

**Table 9. Reg 01h - Settings Register**

BIT	TYPE	NAME	W	DEFLT	DESCRIPTION
[0]	R/W	VCO Buffer Enable	1	1	Enables VCO input RF buffer.
[1]	R/W	Reserved	1	1	Write 0 to this bit.
[2]	R/W	AUXSPI Enable	1	1	Enables Auxiliary SPI.
[3]	R/W	Sigma Delta Enable	1	1	Enables Sigma Delta Function.
[4]	R/W	GPIO Enable	1	1	Enables output from all GPIO pins.
[5]	R/W	RF Divider Enable	1	1	Enables RF Divider.
[6]	R/W	Output Buffer Enable	1	1	Enables Divider Output Driver.
[7]	R/W	Bias Enable	1	1	Enables bias generator for all blocks.
[8]	R/W	PSCLK to Digital Enable	1	1	Enable Prescaler clock going to digital counters.
[9]	R/W	Unused	1	1	

**Table 10. Reg 02h R-Divider Register**

BIT	TYPE	NAME	W	DEFLT	DESCRIPTION
[13:0]	R/W	R Divider Ratio	14	1h	Local value for reference division ratio.

**Auxiliary SPI Registers**

The following two registers define the communication through the AUXSPI. If the AUXSPI is enabled ([Reg 04h](#)[4] = 0), writes to AUXSPI are executed via [Reg 03h](#). The auxiliary device address is expected in [Reg 04h](#)[2:0]. If HMC983LP5E is working as a standalone frequency divider the AUXSPI clock is expected on the DNSAT pin, and [Reg 04h](#)[15] must be set to 1. It is recommended to disable AUXSPI when not used.

**Table 11. Reg 03h AUX. VCO Data Register**

BIT	TYPE	NAME	W	DEFLT	DESCRIPTION
[3:0]	R/W	AUXSPI Register Address	4	0h	4-bit Register address for the auxiliary device SPI.
[12:4]	R/W	AUXSPI Data	9	000h	9-bit long Register Data for the auxiliary device SPI.



**DC - 7 GHZ FRACTIONAL-N DIVIDER  
AND FREQUENCY SWEEPER**

**Table 12. Reg 04h - AUX. VCO Settings Register**

BIT	TYPE	NAME	W	DEFLT	DESCRIPTION
[2:0]	R/W	Auxiliary Device Address	3	000h	Chip address used by AUXSPI.
[3]	R/W	Divide Clock by 4 for AUXSPI	1	0	0 = Use XTAL for AUXSPI clock. 1 = Use XTAL divided by 4 for AUXSPI clock.
[4]	R/W	Start AUXSPI	1	0	0 = Start AUXSPI when data is written to Reg03h. 1 = reserved.
[7:5]	R/W	Reserved	3	4h	
[9:8]	R/W	Reserved	2	2h	
[13:10]	R/W	Reserved	4	8h	
[14]	R/W	Reserved	1	0	
[15]	R/W	Keep Xtal Gate Open	1	0	When 1, keeps the XTAL gate open to get XTAL from the companion PFD/CP chip HMC984LP4E.
[18:16]	R/W	Reserved	3	0h	

**Table 13. Reg 05h Integer Set-Point, Trigger Delay Register**

BIT	TYPE	NAME	W	DEFLT	DESCRIPTION
[19:0]	R/W	Integer Division Ratio	20	200d	Sigma-Delta Modulator integer set point. Specifies the integer part of the division ratio for the RF Divider in fractional mode or the integer division ratio in integer mode.
		Ramp Trigger Delay			Also used as delay counter for hardware ramp trigger (Pin D4) in ramp mode. This value is valid when <a href="#">Reg 0Eh</a> [11] = 1.

**Table 14. Reg 06h Fractional Set-Point, Down Dwell Register (MSB)**

BIT	TYPE	NAME	W	DEFLT	DESCRIPTION
[29:0]	R/W	Fractional Division Ratio (MSB)	30	0	Most significant 30 bits to specify fractional set point for Sigma-Delta Modulator. Total Fractional bits are 48.
		Down Dwell for Asymmetric Frequency. Ramp (MSB)			Defines the MSB portion of the dwell down time in the asymmetric frequency sweep mode, valid when <a href="#">Reg 0Eh</a> [11]=1.

**Table 15. Reg 07h Fractional Set-Point, Down Dwell Register (LSB)**

BIT	TYPE	NAME	W	DEFLT	DESCRIPTION
[17:0]	R/W	Fractional Division Ratio (LSB)	18	0	Least significant 18 bits to specify fractional set point for Sigma-Delta Modulator. Total Fractional bit are 48.
		Down Dwell for Asymmetric Frequency. Ramp (LSB)			Defines the LSB portion of the dwell down time in the asymmetric frequency sweep mode, valid when <a href="#">Reg 0E</a> [11]=1.

**DC - 7 GHZ FRACTIONAL-N DIVIDER  
AND FREQUENCY SWEEPER**
**Table 16. Reg 08h GPIO Configuration Register**

BIT	TYPE	NAME	W	DEFLT	DESCRIPTION
[3:0]	R/W	GPO Output Select	4	0h	Selects exported output signals to GPIO pins. See <a href="#">Table 5</a> for details. Master enable for GPIO <a href="#">Reg 01h[4]</a> = 1 is required.
[8:4]	R/W	GPO Static Test Value	5	00000b	Static GPIO test signals for output (D4,D3,D2,D1,D0). Writing these value and reading them back test the GPIO functionality. Master enable for GPIO <a href="#">Reg 01h[4]</a> = 1 is required.
[13:9]	R/W	GPO Pin Enable	5	11111b	Independent GPIO pin enables. Reg08[13] = 0 - D4 input Reg08[13] = 1 - D4 output Reg08[12] = 0, D3 input Reg08[12] = 1, D3 output Reg08[11] = 0, D2 input Reg08[11] = 1, D2 output Reg08[10] = 0, D1 input Reg08[10] = 1, D1 output Reg08[9] = 0, D0 input Reg08[9] = 1, D0 output Master enable for GPIO <a href="#">Reg 01h[4]</a> = 1 is required.

**Table 17. Reg 09h Companion Chip Address Local Register**

BIT	TYPE	NAME	W	DEFLT	DESCRIPTION
[2:0]	R/W	Counterpart HMC984LP4E Chip Address	3	2h	Chip address of the companion chip HMC984LP4E.

**Table 18. Reg 0Ah Sigma Delta Modulator Seed MSB Register**

BIT	TYPE	NAME	W	DEFLT	DESCRIPTION
[29:0]	R/W	Seed MSB	30	4241h	Most significant bits of the Seed for the 1st accumulator in Sigma-Delta Modulator.

**Table 19. Reg 0Bh Sigma Delta Modulator Seed LSB Register**

BIT	TYPE	NAME	W	DEFLT	DESCRIPTION
[17:0]	R/W	Seed LSB	18	10081h	Least significant bits of the Seed for the 1st accumulator in Sigma-Delta Modulator.

**Table 20. Reg 0Ch Ramp NSTEP Down MSB Register**

BIT	TYPE	NAME	W	DEFLT	DESCRIPTION
[29:0]	R/W	Down Ramp Number of Steps (MSB)	30	0h	Most significant bits of the number of steps for the frequency ramp in down direction in sweep mode.

**Table 21. Reg 0Dh Ramp NSTEP Down LSB Register**

BIT	TYPE	NAME	W	DEFLT	DESCRIPTION
[17:0]	R/W	Down Ramp Number of Steps (LSB)	18	0h	Least significant bits of the number of steps for the frequency ramp in down direction in sweep mode.

**DC - 7 GHZ FRACTIONAL-N DIVIDER  
AND FREQUENCY SWEEPER**
**Table 22. Reg 0Eh Sigma Delta Modulator Configuration Register**

BIT	TYPE	NAME	W	DEFLT	DESCRIPTION
[1:0]	R/W	SD Modulator Type	2	11b	DSM Type. 00 = MASH1 - Reserved 01 = MASH11 - Reserved 10 = MASH111 - Delta Sigma Modulator Mode B 11 = Delta Sigma Modulator Mode A
[2]	R/W	Ramp Auto Repeat Control from SPI	1	0	Recommended to write 1 to this bit in ramp mode. When this bit is 1, the ramp will repeat itself if ramp_auto_repeat_on/off_from_spi is 1 at the end of the each sweep.
[3]	R/W	Ramp Auto Repeat Control from SPI On/Off	1	0	Ramp will automatically repeat itself if this bit is 1 and bit 2 is also set to 1.
[6:4]	R/W	Integer Path Delay	3	111	Delay through the integer signal path to compensate for the fractional path. 000 = no delay. 110 = 6 clock cycles delay. 111 = Automatic.
[7]	R/W	Ramp Start Delay Enable	1	0	Delay the start of sweep as defined in <a href="#">Reg 05h</a>
[8]	R/W	Autoseed Mode Enable	1	1	Reseed when changing the frac setpoint.
[9]	R/W	Reserved	1	0	
[10]	R/W	Maintain DSM State Enable	1	0	Maintain DSM state within the same integer boundary.
[11]	R/W	Ramp Mode Enable	1	0	Puts DSM in frequency sweeper (ramp) mode.
[12]	R/W	Ramp Start from SPI	1	0	Start ramp signal from SPI.
[13]	R/W	Start Ramp from Ext. Trigger	1	0	Allow external trigger to manipulate ramp.
[14]	R/W	Bypass All	1	0	Bypass Delta Sigma Modulator. Place synthesizer in Integer Mode without disabling the DSM.
[18:15]	R/W	CSP Step Size	4	1111b	Cycle Slip Prevention (CSP) step size. In a PLL configuration with the HMC984LP4E one step is equivalent to one divided VCO cycle, and step size is the number of VCO cycles.
[19]	R/W	External DSM Sequence Enable	1	0	Use external DSM sequence imported through GPIO Port.
[20]	R/W	Use Falling Edge of DSM Clock for External Sequence	1	0	Use falling edge of SD clock to get the external sequence.
[21]	R/W	Lock using External Trigger Pin	1	0	Allow external trigger to start locking process. Writing to the Integer or Fractional Division ratio registers does not have any effect when this bit is set to 1. PLL will lock only when external trigger goes high.
[22]	R/W	Symmetrical Ramp Mode	1	1	Use symmetric frequency sweeping for up and down directions otherwise DN parameters are taken from Registers <a href="#">Reg 0Ch</a> , <a href="#">Reg 0Dh</a> , <a href="#">Reg 19h</a> and <a href="#">Reg 1Ah</a> for asymmetric mode.
[23]	R/W	Integer Mode Lock Strobe	1	0	Re-lock when integer set-point <a href="#">Reg 06h</a> is updated.
[24]	R/W	Singlestep Ramp Mode Enable	1	0	Single-step the ramp. Each step of the ramp must be popped by strobe (either SPI or Hardware pin).
[25]	R/W	Single Direction Ramp Mode Enable	1	0	Single direction mode for ramp (ramp one way, pop to base the other way).
[26]	R/W	Ramp Start Direction	1	1	Starting direction of ramp. It is only loaded while rampmode = 0. 1 = Positive 0 = Negative
[27]	R/W	Use External Clock for DSM	1	0	1 = Use external clock from GPIO pin to clock DSM.
[28]	R/W	Reserved	1	0	
[29]	R/W	Use x16 CSP Step	1	0	1 = Increase the CSP step size given in bits [18:15] by a factor of 16.

**DC - 7 GHZ FRACTIONAL-N DIVIDER  
AND FREQUENCY SWEEPER**
**Table 23. Reg 0Fh VCO Divider Configuration Register**

BIT	TYPE	NAME	W	DEFLT	DESCRIPTION
[0]	R/W	Increase Divider Pulse width to DSM	1	0	Increase the width of the clock pulse going to DSM (available only when division ratio > 64).
[1]	R/W	Increase Divider Pulsewidth to PFD	1	1	Increase pulse width (low duration) of the clock going to PFD.
[4:2]	R/W	Output Buffer Current Select	2	011b	Sets current for divider output buffer. Helps to control voltage swing for various impedance options. 000 = 5mA 001 = 7.5mA 010 = 10mA 011 = 12.5mA 100 = 10mA 101 = 12.5mA 110 = 15mA 111 = 17.5mA
[5]	R/W	Reset RF Divider	1	0	Resets the RF Divider.
[8:6]	R/W	Divider Resynch Bias Select	3	011b	Bias current setting for divider resynch. Default value recommended.
[11:9]	R/W	RF Buffer Bias Select	3	001b	Bias current setting for input RF buffer. Default value recommended.
[14:12]	R/W	Divider Pulsewidth Select	3	011b	Divider output pulse width control. 000 = 5 VCO cycles. 001 = 13 VCO cycles. 010 = 21 VCO cycles. 011 = 29 VCO cycles. 100 = 37 VCO cycles. 101 = 45 VCO cycles. 110 = 53 VCO cycles. 111 = 61 VCO cycles.

**Table 24. Reg 10h Ramp DWELL Symmetrical or Up MSB Register**

BIT	TYPE	NAME	W	DEFLT	DESCRIPTION
[29:0]	R/W	Symmetric Ramp Dwell (MSB)	30	0	Represents MSB's for ramp dwell time in up and down directions for symmetric frequency sweep mode. In asymmetric mode it represents the up dwell time only.

**Table 25. Reg 11h Ramp DWELL Symmetrical or Up LSB Register**

BIT	TYPE	NAME	W	DEFLT	DESCRIPTION
[17:0]	R/W	Symmetric Ramp Dwell (LSB)	18	0	Represents LSB's for ramp dwell time in up and down directions for symmetric frequency sweep mode. In asymmetric mode it represents the up dwell time only.

**Table 26. Reg 12h Ramp Step Size Symmetrical or Up MSB Register**

BIT	TYPE	NAME	W	DEFLT	DESCRIPTION
[29:0]	R/W	Symmetric Ramp Step Size (MSB)	30	0	Represents the MSB for ramp step size in up and down directions for symmetric frequency sweep mode. In asymmetric mode it represents the up step size only.



**DC - 7 GHZ FRACTIONAL-N DIVIDER  
AND FREQUENCY SWEEPER**

**Table 27. Reg 13h Ramp Step Size Symmetrical or Up LSB Register**

BIT	TYPE	NAME	W	DEFLT	DESCRIPTION
[17:0]	R/W	Symmetric Ramp Step Size (LSB)	18	0	Represents the LSB for ramp step size in up and down directions for symmetric frequency sweep mode. In asymmetric mode it represents the up step size only.

**Table 28. Reg 14h Ramp NSTEP Symmetrical or Up MSB Register**

BIT	TYPE	NAME	W	DEFLT	DESCRIPTION
[29:0]	R/W	Symmetric Ramp Number of Steps (MSB)	30	0	Represents the MSB of the number of steps for the frequency ramp in up and down directions in symmetric frequency sweep mode. In asymmetric mode it represents the number of steps in up direction only.

**Table 29. Reg 15h Ramp NSTEP Symmetrical or Up LSB Register**

BIT	TYPE	NAME	W	DEFLT	DESCRIPTION
[17:0]	R/W	Symmetric Ramp Number of Steps (LSB)	18	0	Represents the LSB of the number of steps for the frequency ramp in up and down directions in symmetric frequency sweep mode. In asymmetric mode it represents the number of steps in up direction only.

**Table 30. Reg 16h DSM Configuration Register**

BIT	TYPE	NAME	W	DEFLT	DESCRIPTION
[1:0]	R/W	DSM 1st Accumulator Size	2	00b	DSM 1st accumulator width. 00 = 48 bits 01 = 32 bits 10 = 24 bits 11 = 16 bits
[3:2]	R/W	DSM 2nd Accumulator Size	2	00b	DSM 2nd accumulator width. 00 = 48 bits 01 = 32 bits 10 = 24 bits 11 = 16 bits
[5:4]	R/W	DSM 3rd Accumulator Size	2	00b	DSM 3rd accumulator width. 00 = 48 bits 01 = 32 bits 10 = 24 bits 11 = 16 bits
[8:6]	R/W	Disable Frac. Register Clock	3	000b	Clock gates for the 3 accumulators (fractional part), 1 disables the clock.
[11:9]	R/W	Disable Integer Register Clock	3	000b	Clock gates for the 3 accumulators (integer part), 1 disables the clock.
[12]	R/W	Disable DSM Mode A Clock	1	0	1 = Disable Delta Sigma Modulator Mode A Clock
[13]	R/W	Disable DSM Mode B Clock	1	0	1 = Disable Delta Sigma Modulator Mode B Clock
[14]	R/W	Reserved	1	0	
[15]	R/W	Disable Integer Path Clock	1	0	1 = Disables Integer Path Clock
[16]	R/W	Disable Input Buffer Clock	1	0	1 = Disables Input Buffer Clock
[17]	R/W	Disable Output Buffer Clock	1	0	1 = Disables Output Buffer Clock
[18]	R/W	Reserved	1	0	
[19]	R/W	Reserved	1	0	

**DC - 7 GHZ FRACTIONAL-N DIVIDER  
AND FREQUENCY SWEEPER**
**Table 31. Reg 17h This Register does not exist**

BIT	TYPE	NAME	W	DEFLT	DESCRIPTION
This Register does not exist					

**Table 32. Reg 19h Ramp Down Step Size MSB Register**

BIT	TYPE	NAME	W	DEFLT	DESCRIPTION
[29:0]	R/W	Ramp Step Down MSB.	30	0	Represents MSB's to define the step size for the ramp in down direction in ramp mode.

**Table 33. Reg 1Ah Ramp Down Step Size LSB Register**

BIT	TYPE	NAME	W	DEFLT	DESCRIPTION
[17:0]	R/W	Ramp Step Down LSB.	18	0	Represents LSB's to define the step size for the ramp in down direction in ramp mode.



**DC - 7 GHZ FRACTIONAL-N DIVIDER  
AND FREQUENCY SWEEPER**

**NOTES:**





## Стандарт Электрон Связь

Мы молодая и активно развивающаяся компания в области поставок электронных компонентов. Мы поставляем электронные компоненты отечественного и импортного производства напрямую от производителей и с крупнейших складов мира.

Благодаря сотрудничеству с мировыми поставщиками мы осуществляем комплексные и плановые поставки широчайшего спектра электронных компонентов.

Собственная эффективная логистика и склад в обеспечивает надежную поставку продукции в точно указанные сроки по всей России.

Мы осуществляем техническую поддержку нашим клиентам и предпродажную проверку качества продукции. На все поставляемые продукты мы предоставляем гарантию .

Осуществляем поставки продукции под контролем ВП МО РФ на предприятия военно-промышленного комплекса России , а также работаем в рамках 275 ФЗ с открытием отдельных счетов в уполномоченном банке. Система менеджмента качества компании соответствует требованиям ГОСТ ISO 9001.

Минимальные сроки поставки, гибкие цены, неограниченный ассортимент и индивидуальный подход к клиентам являются основой для выстраивания долгосрочного и эффективного сотрудничества с предприятиями радиоэлектронной промышленности, предприятиями ВПК и научно-исследовательскими институтами России.

С нами вы становитесь еще успешнее!

### Наши контакты:

**Телефон:** +7 812 627 14 35

**Электронная почта:** [sales@st-electron.ru](mailto:sales@st-electron.ru)

**Адрес:** 198099, Санкт-Петербург,  
Промышленная ул, дом № 19, литера Н,  
помещение 100-Н Офис 331