

MAX32650 Evaluation Kit

Evaluates: MAX32650–MAX32652

General Description

The MAX32650 EV kit provides a platform for evaluating the capabilities of the MAX32650 ultra-low power memory-scalable microcontroller designed specifically for high performance battery powered applications.

EV Kit Contents

- MAX32650 EV kit containing a MAX32650 with a preprogrammed demo
- JTAG debugger with ribbon cable
- Two standard A to Micro B USB cables

Ordering Information

PART	TYPE
MAX32650-EVKIT#	EV Kit

#Denotes RoHS compliant.

Benefits and Features

- 3.5in 320 x 240 Color TFT Display
- 64MB HyperRAM
- 64MB XIP Flash
- 1MB XIP RAM
- USB 2.0 Micro B Interface
- USB 2.0 Micro B to Serial UARTs
 - Selection with Jumpers Between UART0 and UART2
- Micro SD Card Interface
- Select GPIOs Accessed through 0.1in Header
- Access to the Four Analog Input Through 0.1in Header
- Arm® or SWD JTAG 20-Pin Header
- On-Board PMIC to Source Power for the MAX32650
- Board Power Provided by Either USB Port
- Individual Power Measurement on All IC Rails Through Jumpers
- On-Board 1.8V and 3.3V Regulators for Peripherals
- Two General-Purpose LEDs and Two General-Purpose Pushbutton Switches

Arm is a registered trademark of Arm Limited (or its subsidiaries) in the US and/or elsewhere.



MAX32650 EV Kit Board

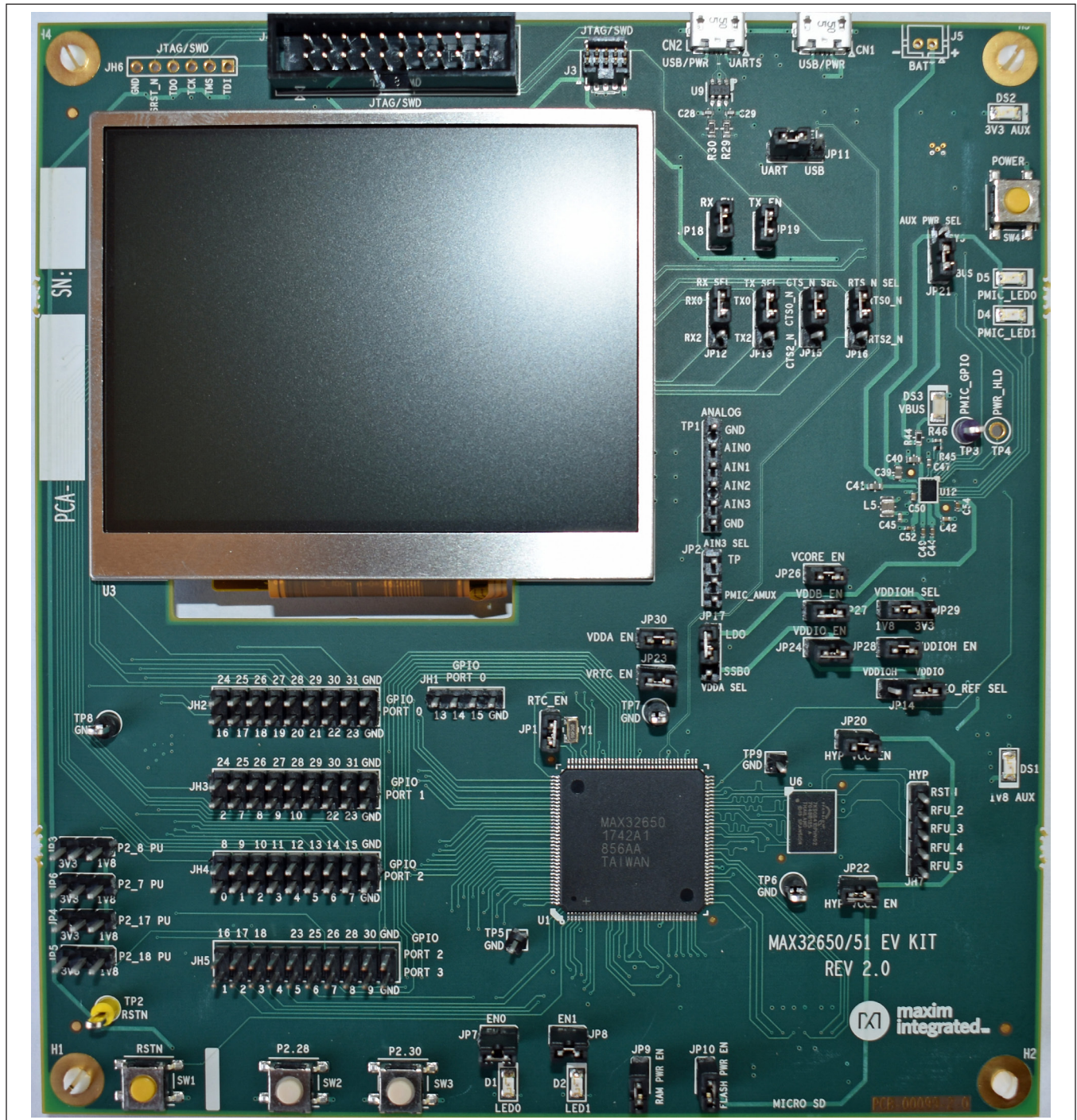

Quick Start

Procedure

Follow the steps below to verify board operation:

- 1) While observing safe ESD practices, carefully remove the MAX32650 EV kit board out of its packaging. Quickly inspect the board to ensure that no damage occurred during shipment. Jumpers/shunts are pre-installed prior to testing and packaging.
- 2) The MAX32650 is preprogrammed with a demo program. To power up the board and run the demo. Verify that the board is powered up by observing that the blue LED (DS3) and the green LEDs (DS1 and DS2) are illuminated.
- 3) Once power is applied, the demo initiates and displays the Maxim logo upon successful completion.

Detailed Description of Hardware

Power Supply

The EV kit is powered by +5V and is made available through VBUS on the Micro-USB type-B connectors CN1 or CN2. This sources the MAX77650 PMIC that provides power to the MAX32650 rails. The board is default jumpered for power provided by CN1. A blue LED (DS3) illuminates when the board is powered. Green LEDs DS1 and DS2 illuminate when the 1V8 and 3V3 LDOs are powered, respectively. These are dedicated for sourcing power to the board peripherals.

Current Monitoring

Jumpers provide convenient current monitoring points for VRTC (J6), VDDIO (J7), VDDIOH (J8 or J11), VCORE (J9), VDDB (J10) and VDDA (J12).

Clocking

The IC nominally operates from an internal oscillator of 120MHz. Three other lower frequency oscillators can be selected depending on power needs. There is an internal 32.768 oscillator that requires an external 32.768kHz crystal (Y1), for accurate RTC timekeeping and USB operation.

Color TFT Display

The display provided is a 3.5in 320 x 240 color TFT. It has three-wire serial control, a 24-bit parallel RGB interface with a white LED backlight.

Universal Serial Bus

A USB Micro B connector (CN1) is provided for prototyping USB slave applications. The USB 2.0 full-speed interface (480Mbps) transceiver is embedded in the MAX32650.

UART Interfaces

The EV kit provides a USB-to-UART bridge chip, FTDI FT230X. This bridge eliminates the requirement for a physical RS-232 COM port. Instead, the IC's UART access is through the Micro-USB type-B connector, CN2. The USB-to-UART bridge can be connected to UART 0 or UART 2 of the IC with jumpers JP12 (RX), JP13 (TX), JP15 (CTS), and JP16 (RTS). Virtual COM port drivers and guides for installing Windows® drivers are available at the FTDI chip website.

Windows is a registered trademark and registered service mark of Microsoft Corporation.

Arm JTAG Connectors

The Arm standard 20-pin connector pinout is provided by shrouded header J4. JH6 is provided as an optional debugging access point, it is not populated by default. The JTAG debugger is supplied with the EV kit. JTAG logic levels are fixed to VDDIO (1.8V).

JTAG Serial Wire Debug (SWD) Support

SWD is supported by the IC and this EV kit. The port shares its clock (SWCLK) with JTAG TCK and a bidirectional data pin (SWDIO) is shared with JTAG TMS.

Reset Pushbutton

Pushbutton SW3 manually resets the MAX32650.

Indicator LEDs

The indicator LEDs D1 (red) and D2 (green) are connected to GPIO P2.25 and P2.26, respectively. The GPIOs need to be configured for 3.3V or open drain since they are sourced at 3.3V.

GPIO Pushbuttons

The two pushbuttons (SW2 and SW3) are connected to GPIO P2.28 and P2.30, respectively. If the pushbutton is pressed, the attached port pin is pulled low.

GPIO Headers

Select GPIOs are accessible through a 0.1in spaced header pins. The IC provides support for both 1.8V and 3.3V peripherals through power rails VDDIO and VDDIOH. GPIO voltages can be programmed on pin-by-pin basis. Refer to the IC's operating guide for more detail.

VIO_REF Setting

The VIO_REF voltage is set by jumper JP14 and was originally selectable between VDDIO and VDDIOH. This, however, can place 3.3V on the pullup (R1) on RSTN and cause an extra $\sim 2\mu\text{A}$ of current to be driven in RSTN. To prevent this, JP14 position 3 has been clipped and VIO_REF jumpered to VDDIO.

Table 1. Jumper Settings

JUMPER	SIGNAL	SETTINGS	DESCRIPTION
JP1	32KIN	1-2*	Connects 32KIN to the 32.768kHz crystal
		Open	Disconnects 32KIN to the 32.768kHz crystal
JP2	AIN3	1-2	Connects analog header TP1 to AIN3
		2-3	Connects PMIC_AMUX TP1 to AIN3
JP3	P2_8	1-2*	Connects 1.8V pullup to P2_8
		2-3*	Connects 3.3V pullup to P2_8
JP4	P2.17	1-2	Connects 1.8V pullup to P2.17
		2-3	Connects 3.3V pullup to P2.17
JP5	P2.18	1-2	Connects 1.8V pullup to P2.18
		2-3	Connects 3.3V pullup to P2.18
JP6	P2.7	1-2	Connects 1.8V pullup to P2.7
		2-3	Connects 3.3V pullup to P2.7

*Denotes default setting.

Table 1. Jumper Settings (continued)

JUMPER	SIGNAL	SETTINGS	DESCRIPTION
JP7	P2.25	1-2*	Connects LED D1 to P2.25
		Open	Disconnects LED D1 to P2.25
JP8	P2.26	1-2*	Connects LED D2 to P2.26
		Open	Connects LED D2 to P2.26
JP9	RAM XIP VCC	1-2*	Connects 1V8_AUX to RAM XIP VCC
		Open	Disconnects 1V8_AUX to RAM XIP VCC
JP10	FLASH XIP VCC	1-2*	Connects 1V8_AUX to FLASH XIP VCC
		Open	Disconnects 1V8_AUX to FLASH XIP VCC
JP11	VBUS	1-2	Connects USB port to VBUS
		2-3*	Connects USB-UART port to VBUS
JP12	TXD of USB-Serial IC	1-2*	Connects TXD of USB-Serial IC to P2.11 (UART0_RX)
		2-3	Connects TXD of USB-Serial IC to P2.1 (UART2_RX)
JP13	RXD of USB-Serial IC	1-2*	Connects RXD of USB-Serial IC to P2.12 (UART0_TX)
		2-3	Connects RXD of USB-Serial IC to P1.10 (UART2_TX)
JP14	VIO_REF	1-2*	Connects VDDIO to VIO_REF
		2-3	Connects VDDIOH to VIO_REF
JP15	RTS of USB-Serial IC	1-2*	Connects RTS of USB-Serial IC to P2.9 (UART0_CTS0)
		2-3	Connects RTS of USB-Serial IC to P1.7 (UART2_CTS2)
JP16	CTS of USB-Serial IC	1-2*	Connects CTS of USB-Serial IC to P2.10 (UART0_RTS0)
		2-3	Connects CTS of USB-Serial IC to P1.8 (UART2_RTS2)
JP17	VDDA	1-2	Connects VDDA to LDO of the PMIC
		2-3*	Connects VDDA to SSB0 of the PMIC
JP18	TXD of USB-Serial IC	1-2*	Connects TXD of USB-Serial IC to JP12 RX SEL jumper
		Open	Disconnects TXD of USB-Serial IC to JP12 RX SEL Jumper
JP19	RXD of USB-Serial IC	1-2*	Connects RXD of USB-Serial IC to JP13 TX SEL Jumper
		Open	Disconnects RXD of USB-Serial IC to JP13 TX SEL Jumper
JP20	HyperRAM VCC	1-2*	Connects 1V8_AUX to VCC Hyper RAM VCC
		Open	Disconnects 1V8_AUX to VCC Hyper RAM VCC
JP21	3V3 LDO VCC	1-2*	Connects PMIC SYS to 3V3 LDO
		Open	Connects VBUS to 3V3 LDO
JP22	HyperRAM VCCQ	1-2*	Connects 1V8_AUX to VCC Hyper RAM VCCQ
		Open	Disconnects 1V8_AUX to VCC Hyper RAM VCCQ
JP23	VRTC	1-2*	Connects PMIC SBB0 to VRTC
		Open	Disconnects PMIC SBB0 to VRTC
JP24	VDDIO	1-2*	Connects PMIC SBB0 to VDDIO
		Open	Disconnects PMIC SBB0 to VDDIO

*Denotes default setting.

Table 1. Jumper Settings (continued)

JUMPER	SIGNAL	SETTINGS	DESCRIPTION
JP25	N/A	N/A	Jumper not present
		N/A	Jumper not present
JP26	VCORE	1-2*	Connects PMIC SBB1 to VCORE
		Open	Disconnects PMIC SBB1 to VCORE
JP27	VDDB	1-2*	Connects PMIC SBB2 to VDDB
		Open	Disconnects PMIC SBB2 to VDDB
JP28	VDDIOH	1-2*	Connects PMIC power to VDDIOH
		Open	Disconnects PMIC power to VDDIOH
JP29	VDDIOH	1-2*	Connects PMIC SBB0 (1.8V) to VDDIOH
		2-3	Disconnects PMIC SBB2 (3.3V) to VDDIOH
JP30	VDDA	1-2*	Connects PMIC power (LDO or SSB0) to VDDA
		Open	Disconnects PMIC power (LDO or SSB0) to VDDA

*Denotes default setting.

MAX32650 EV Kit Bill of Materials

Qty	Part Reference	Value	BOM Description	Manufacturer PN	Manufacturer
8	C1,C3,C4,C6,C7,C8,C46,C47	1uF	CAP CER 1UF 6.3V X5R 0402	GRM155R60J105KE19D	Murata
4	C2,C5,C9,C10	150pF	CAP CER 150PF 50V 5% COG 0603	C1608COG1H151J080AA	TDK Corporation
5	C11,C30,C37,C40,C41	4.7uF	CAP CER 4.7uF 10V 10% X5R 0603	C0603C475K8PACTU	Kemet
6	C12,C14,C20,C21,C36,C38	1uF	CAP CER 1uF 16V 10% X7R 0603	GCM188R71C105KA64D	Murata
1	C13	10pF	CAP CER 10pF 50V 5% NPO 0603	06035A100JAT2A	AUX
14	C15,C16,C17,C18,C19,C22,C23,C26,C31,C34,C44,C49,C52,C54	100nF	CAP CER 0.1UF 10V 10% X5R 0402	GRM155R61A104KA01D	Murata
2	C24,C32	100nF	CAP CER 0.1UF 25V 10% X8R 0603	C1608X8R1E104K080AA	TDK Corporation
1	C25	1uF	CAP CER 1UF 35V 10% X5R 0603	GMK107BJ105KA-T	Taiyo Yuden
1	C27	10nF	CAP CER 10nF 25V 10% X7R 0603	GRM188R71E103KA01D	Murata
2	C28,C29	47pF	CAP CER 47PF 50V 1% NPO 0402	C1005COG1H470F050BA	TDK Corporation
1	C33	100nF	CAP CER 0.1uF 16V 10% X7R 0603	C0603C104K4RACTU	Kemet
1	C35	10uF	CAP CER 10uF 10V 10% X7R 0805	GRM21BR71A106KE51L	Murata
1	C39	22uF	CAP CER 22UF 4V 20% X5R 0603	AMK107BJ226MA-T	Taiyo Yuden
4	C42,C43,C50,C51	10uF	CAP CER 10UF 6.3V 20% X5R 0402	GRJ155R60J106ME11D	Murata Electronics
1	C45	3.3nF	CAP CER 3300PF 16V 10% X7R 0402	GRM15XR71C332KA86D	Murata Electronics
2	C48,C53	4.7uF	CAP CER 4.7UF 4V 20% X5R 0402	AMK105BJ475MV-F	Taiyo Yuden
1	CN1, CN2	MICRO USB B R/A	CONN RCPT 5POS MICRO USB B R/A	47346-0001	Molex
2	D1,D5	RED	LED 660NM RED WTR CLR 1206 SMD	SML-LX1206SRC-TR	Lumex Opto
4	D2,D4,DS1,DS2	GRN	LED 565NM WTR CLR GREEN 1206 SMD	SML-LX1206GC-TR	Lumex Opto
1	D3	CMOSH-3	Schottky Diode 30V 100mA	CMOSH-3	Central Semiconductor
1	DS3	BLUE	LED 469NM BLUE DIFF 1206 SMD	HSMR-C150	Avago Technologies US Inc.
4	H1,H2,H3,H4	DNI	DNI MTG 125DRL 300PAD		
1	J1	047571-0001	CONN MICRO SD CARD PUSH-PULL R/A	047571-0001	Molex
1	J2	54P 0.5mm	CONN FFC/FPC 54POS ZIF .5MM SMD	512965494	Molex Inc
1	J3	10P CORTEX DEBUG	CONN HEADER 10POS DUAL .05" SMD	FTSH-105-01-F-DV-K	Samtec
1	J4	20P 10x2	CONN HEADER 2.54MM 20POS GOLD	SBH11-PBPC-D10-ST-BK	Sullins
1	J5	2POS 2MM	CONN HEADER PH TOP 2POS 2MM	B2B-PH-K-S(LF)(SN)	JST Sales America Inc
15	JP1,JP7,JP8,JP9,JP10,JP18,JP19,JP20,JP22,JP23,JP24,JP26,JP27,JP28,JP30	JUMPER	CONN HEADER .100 SINGL STR 2POS	PEC02SAAN	Sullins
1	JH1	4P 1x4	CONN HEADER .100 SINGL STR 4POS	PEC04SAAN	Sullins
3	JH2,JH3,JH4	18P 2x9	CONN HEADER .100 DUAL STR 18POS	PEC09DAAN	Sullins
1	JH5	20P 2x10	CONN HEADER .100 DUAL STR 20POS	PEC10DAAN	Sullins
1	JH6	6P 1x6	CONN HEADER .100 SINGL STR 6POS	PEC06SAAN	Sullins
1	JH7	5P 1x5	CONN HEADER .100 SINGL STR 5POS	PEC05SAAN	Sullins
14	JP2,JP3,JP4,JP5,JP6,JP11,JP12,JP13,JP14,JP15,JP16,JP17,JP21,JP29	3P 3x1	CONN HEADER .100 SINGL STR 3POS	PEC03SAAN	Sullins
1	L1	22uH	INDUCTOR POWER 22UH 20% SMD	CLF6045T-220M	TDK Corporation
2	L2,L4	HZ1206C202R-10	FERRITE CHIP SIGNAL 2000 OHM SMD	HZ1206C202R-10	Laird-Signal Integrity Products
1	L3	BLM21PG221SN1D	FERRITE CHIP 220 OHM 0805	BLM21PG221SN1D	Murata Electronics
1	L5	1.5uH	Fixed Inductors 0806 1.5uH 20% 1.5A	DFE201610E-1R5M=P2	Murata Electronics
1	PCB1	PCB			

MAX32650 EV Kit Bill of Materials (continued)

Qty	Part Reference	Value	BOM Description	Manufacturer PN	Manufacturer
1	Q1	BSS806N	MOSFET N-CH 20V 2.3A SOT23	BSS806N H6327	Infineon Technologies
13	R1,R12,R13,R14,R15,R16,R17, R25,R28,R31,R32,R39,R47	10K	RES 10K OHM 1/10W 1% 0603 SMD	ERJ-3EKF1002V	Panasonic
4	R2,R4,R6,R8	33.2	RES 33.2 OHM 1/10W 1% 0603 SMD	ERJ-3EKF33R2V	Panasonic
4	R3,R5,R7,R9	49.9	RES 49.9 OHM 1/10W 1% 0603 SMD	ERJ-3EKF49R9V	Panasonic
5	R10,R11,R18,R19,R45	10K	RES 10K OHM 1/10W 1% 0402 SMD	ERJ-2RKF1002X	Panasonic
2	R20,R21	100	RES 100 OHM 1/10W 1% 0603 SMD	ERJ-3EKF1000V	Panasonic
1	R22	470	RES 470 OHM 1/10W 1% 0603 SMD	ERJ-3EKF4700V	Panasonic
3	R23,R41,R42	332	RES 332 OHM 1/10W 1% 0603 SMD	ERJ-3EKF3320V	Panasonic
1	R24	137K	RES SMD 137K OHM 1% 1/10W 0603	ERJ-3EKF1373V	Panasonic
1	R26	10K	RES 10K OHM 1/10W 1% 0603 SMD	ERJ-3EKF1002V	Panasonic
1	R27	1M	RES SMD 1M OHM 5% 1/8W 0805	ERJ-6GEYJ105V	Panasonic
2	R29,R30	27	RES 27 OHM 1/10W 1% 0603 SMD	ERJ-3EKF27R0V	Panasonic
5	R35,R36,R37,R38,R40	DNI	DNI 0402		
1	R43	150K	RES 150K OHM 1/10W 1% 0603 SMD	ERJ-3EKF1503V	Panasonic
1	R44	2.7K	RES 2.7K OHM 1/10W 1% 0603 SMD	ERJ-3EKF2701V	Panasonic
1	R46	10K	NTC THERMISTOR 10K OHM 1% 0402	NCP15XH103F03RC	Murata Electronics
2	SW1,SW4	B3S-1002 BY OMZ	SWITCH TACTILE SPST-NO 0.05A 24V	B3S-1002 BY OMZ	Omron Electronics
2	SW2,SW3	B3S-1000	SWITCH TACTILE SPST-NO 0.05A 24V	B3S-1000	Omron Electronics
1	TP1	6P 1x6	CONN HEADER .100 SINGL STR 6POS	PEC06SAAN	Sullins
1	TP2	YLV	TEST POINT PC MULTI PURPOSE YEL	5014	Keystone Electronics
1	TP3	PRPL	TEST POINT PC MULTI PURPOSE PRPL	5129	Keystone Electronics
1	TP4	YLV	TEST POINT PC MULTI PURPOSE YEL	5014	Keystone Electronics
2	TP5,TP9	1P	CONN HEADER .100 SINGL STR 1POS	PEC01SAAN	Sullins
3	TP6,TP7,TP8	BLK	TEST POINT PC COMPACT .063"D BLK	5006	Keystone Electronics
1	U1	MAX32650ICE+	MAX32650ICE+ 144P TQFP	MAX32650ICE+	Maxim Integrated
1	U2	MAX8574EUT+T	IC CONV LCD BOOST SOT23-6	MAX8574EUT+T	Maxim Integrated
1	U3	NHD-3.5-320240MF-ATXL#-1	LCD DISP TFT 3.5" 320X240 B/L	NHD-3.5-320240MF-ATXL#-1	Newhaven Display Intl
1	U4	MX25U6435FM2I-10G	IC FLASH 64MBIT 104MHZ 8SOP	MX25U6435FM2I-10G	Macronix
1	U5	N01S818HAT22I	IC SRAM 1MBIT 20MHZ 8TSSOP	N01S818HAT22I	ON Semiconductor
1	U6	S27KS0641DPBH020	IC HYPERRAM 64Mb 24BGA 166MHz		Cypress Semiconductor
2	U7,U9	MAX3207EAUT+T	ESD PROT DIFF SOT23-6	MAX3207EAUT+T	Maxim Integrated
1	U8	FT230XS-R	IC USB SERIAL BASIC UART 16SSOP	FT230XS-R	FTDI
1	U10	MAX1806EUA33+	IC REG LDO 3.3V/ADJ 0.5A 8UMAX	MAX1806EUA33+	Maxim Integrated
1	U11	MAX1818EUT18+	IC REG LDO 1.8V/ADJ 0.5A SOT23-6	MAX1818EUT18+	Maxim Integrated
1	U12	MAX77650	max77650 PMIC	MAX77650	Maxim Integrated
1	Y1	32.768kHz	CRYSTAL 32.768KHZ 6.0PF SMD	ABS07-32.768KHZ-6-T	Abracon Corp

MAX32650 EV Kit Schematics

NOTES:

PCB1
PCB-00099-2-0

DAUGHTERBOARD STANDOFF HOLES

Copyright © 2013 - Maxim Integrated		 maxim integrated	
Title: MAX32650 EV Kit - Rev History & Notes			
Size: 11x17	Document Number: SC-00099	Rev: 2.0	
Date: Thursday, January 18, 2018		Sheet: 1	of: 8

Maxim cannot assume responsibility for use of any circuitry other than circuitry entirely embodied in a Maxim product. No circuit patent licenses are implied. Maxim reserves the right to change the circuitry and specifications without notice at any time.

MAX32650 EV Kit Schematics (continued)

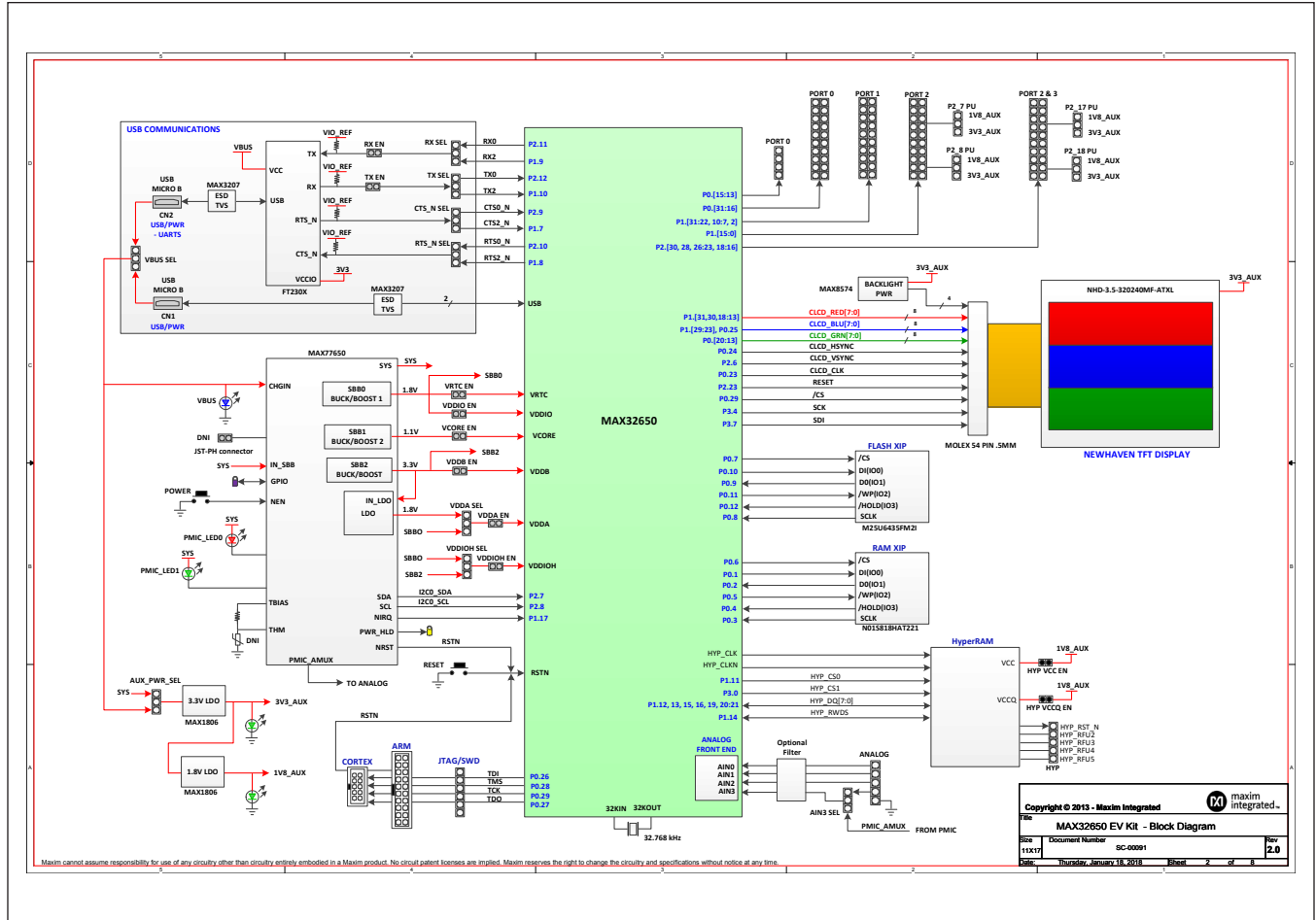

MAX32650 EV Kit Schematics (continued)

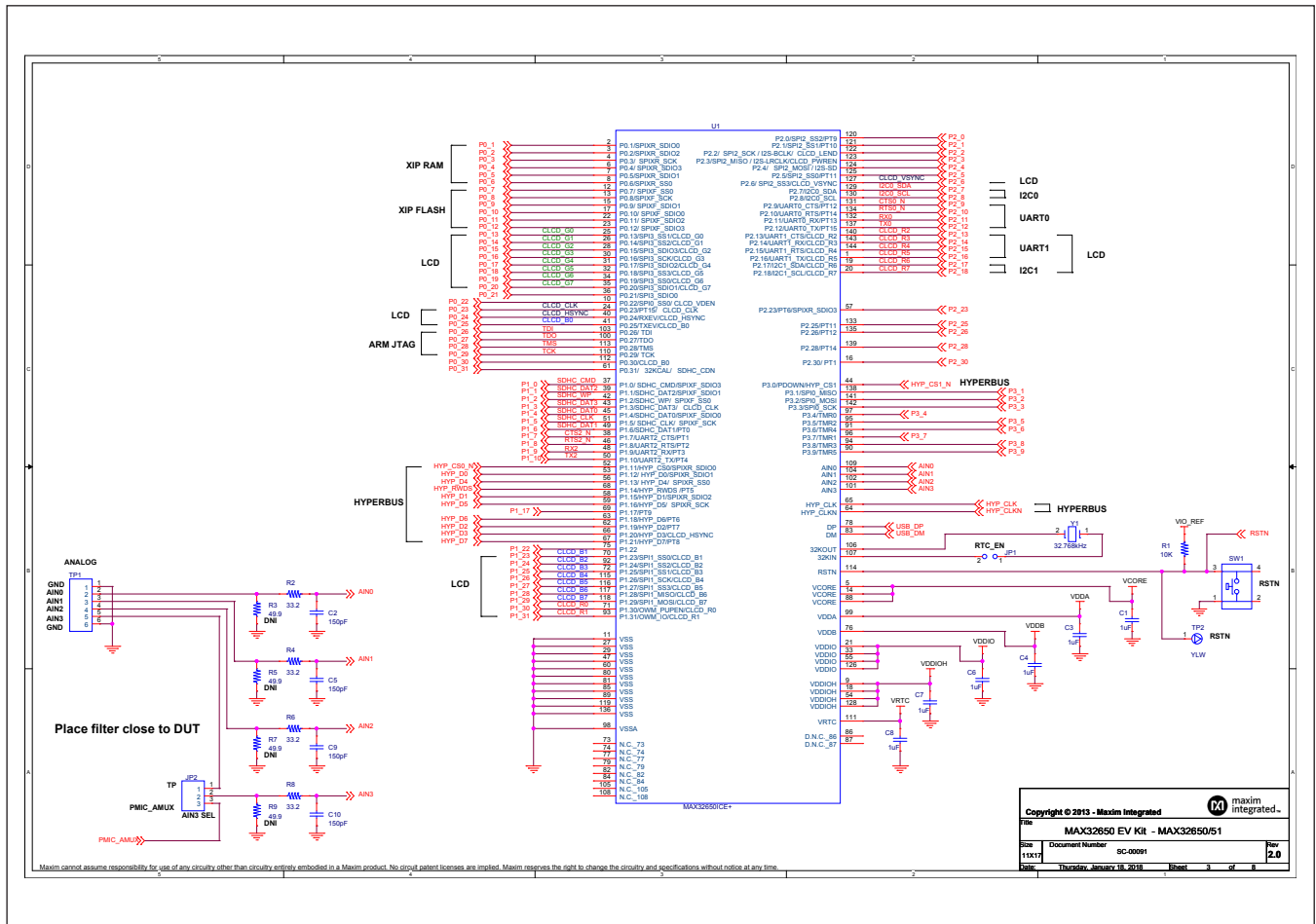

MAX32650 EV Kit Schematics (continued)

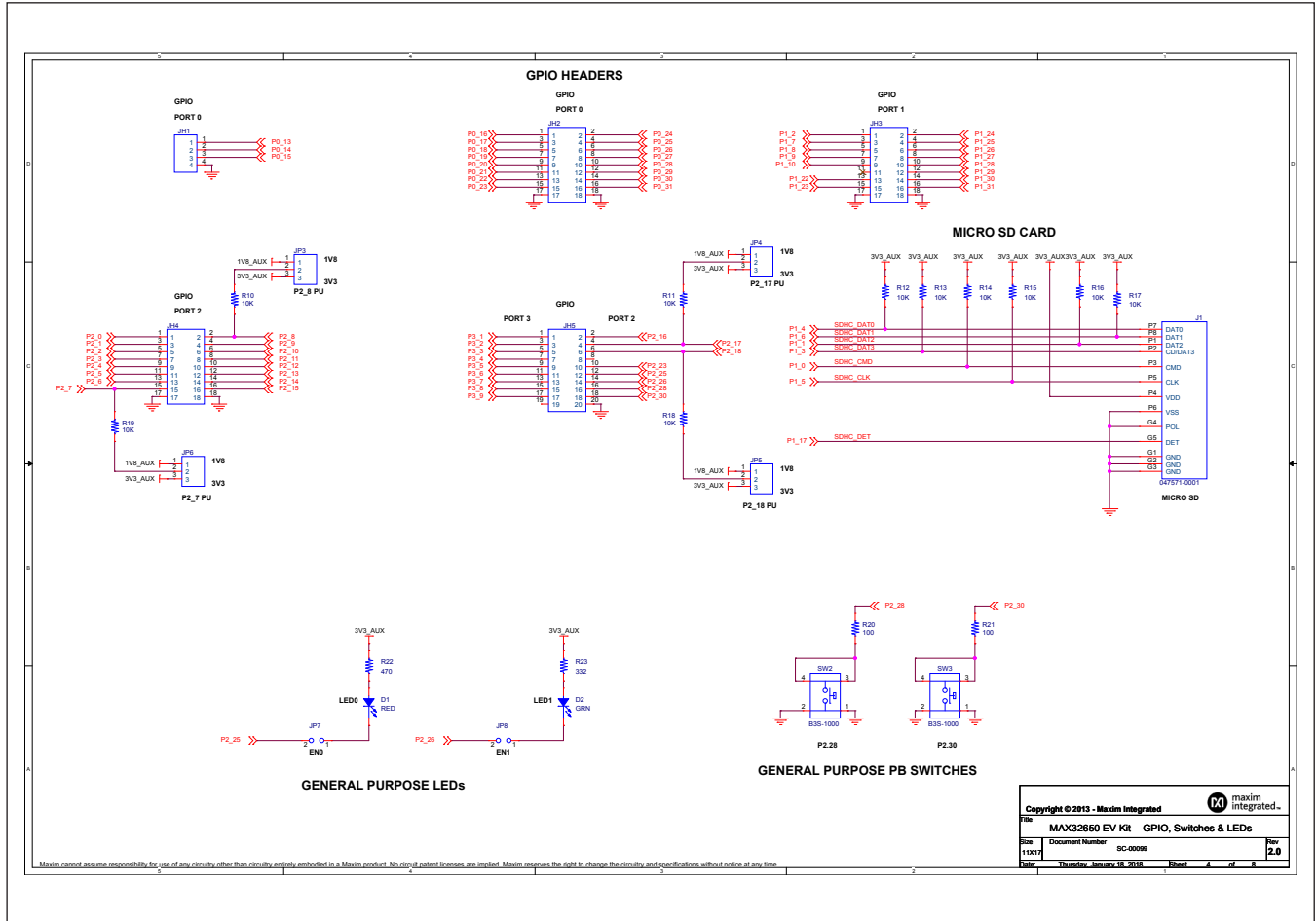

Copyright © 2013 - Maxim Integrated		
MAX32650 EV Kit - GPIO, Switches & LEDs		
Doc ID: 11517	Document Number: 5C-00099	Rev: 2.0
Date: Thursday, January 18, 2018	Sheet: 4	of 8

MAX32650 EV Kit Schematics (continued)

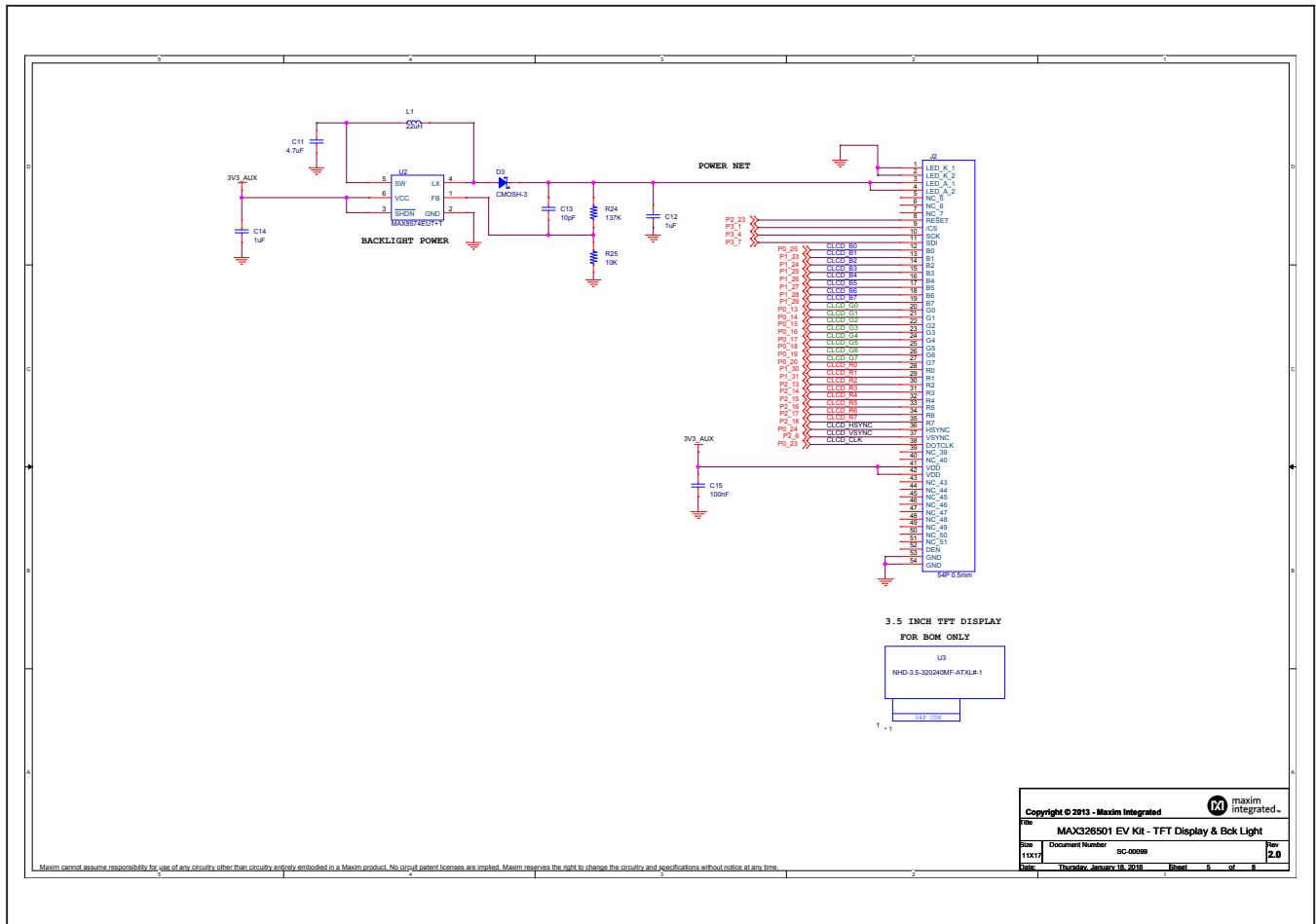

MAX32650 EV Kit Schematics (continued)

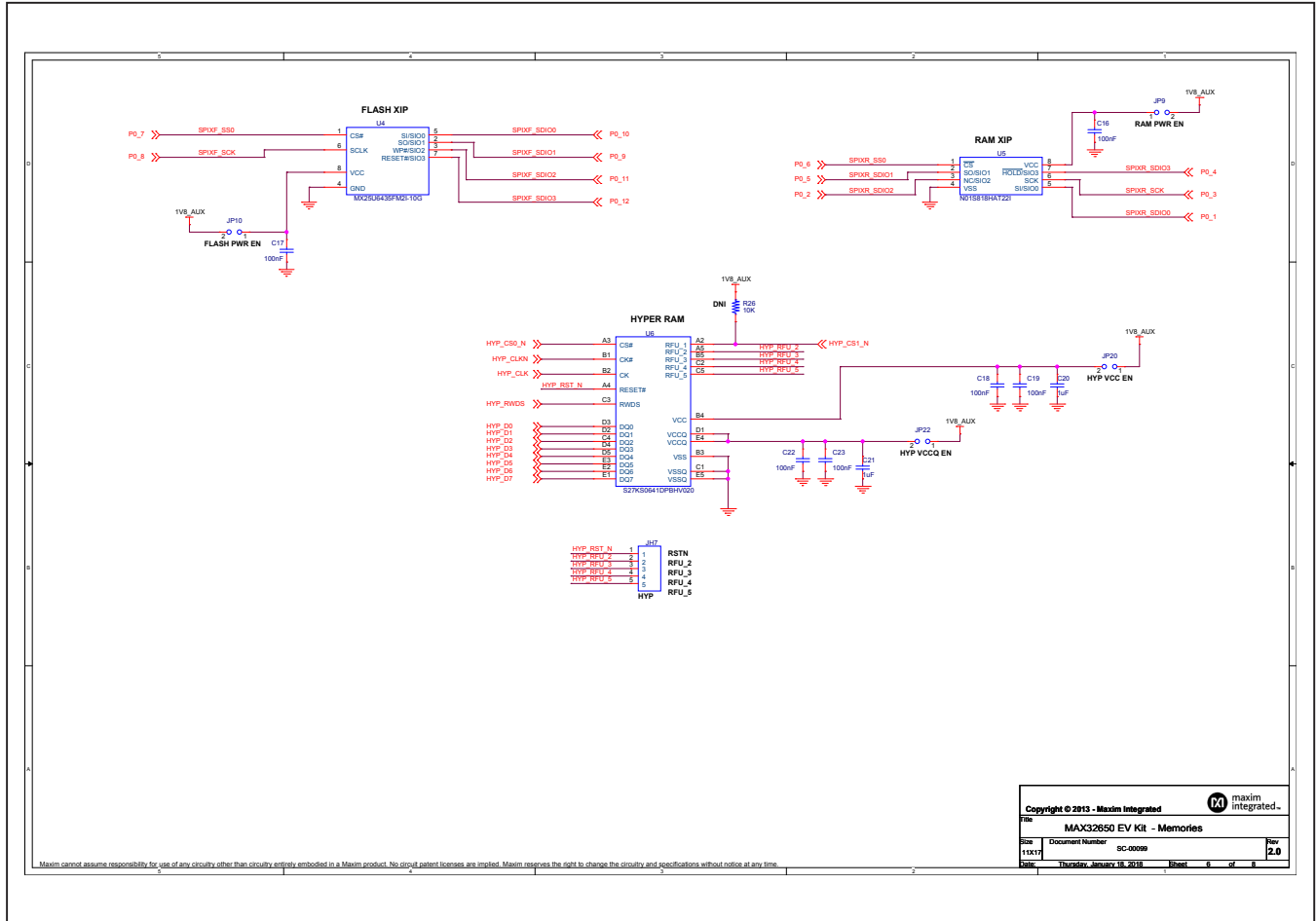

MAX32650 EV Kit Schematics (continued)

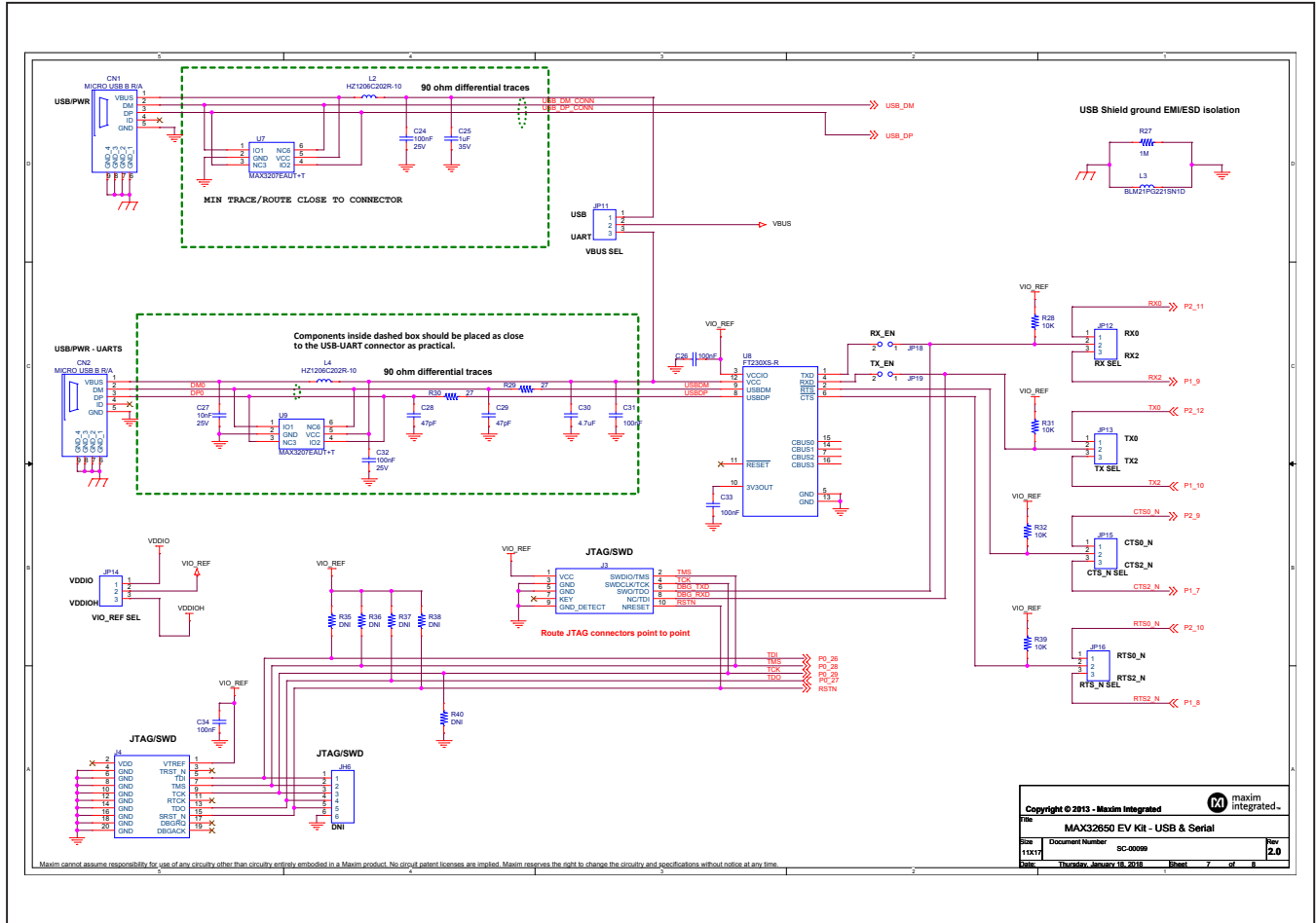

MAX32650 EV Kit Schematics (continued)

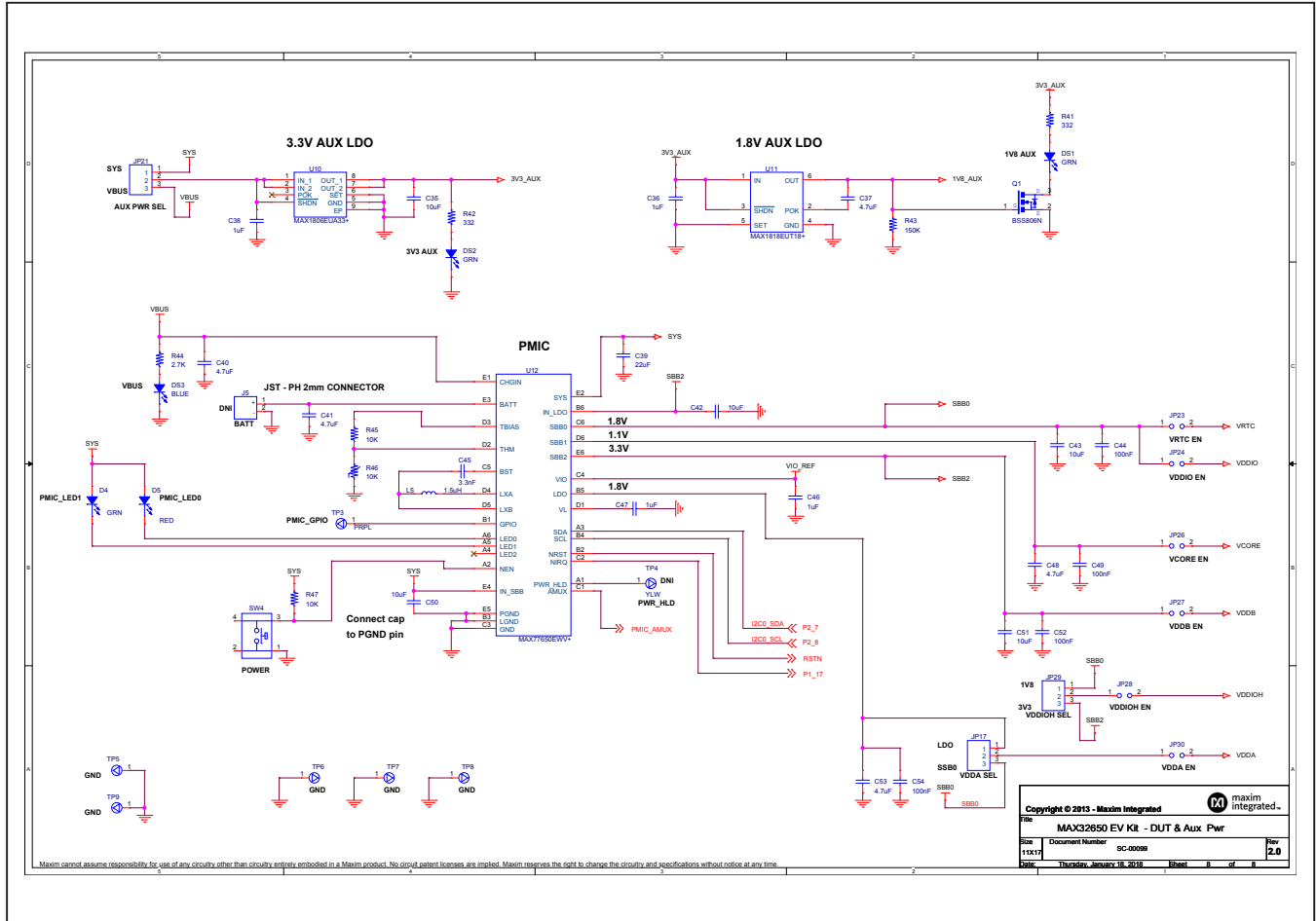

Revision History

REVISION NUMBER	REVISION DATE	DESCRIPTION	PAGES CHANGED
0	10/17	Initial release	—
1	1/18	Updated <i>MAX32650 EV Kit Board Photo, Procedure, Arm JTAG Connectors, Table 1, and MAX32650 EV Kit Bill of Materials</i> , and added <i>VIO_REF Settings</i>	2–7
2	2/18	Added MAX32651 and MAX32652 to data sheet, updated schematics	1–17
3	3/18	Updated orderable part number	1

For pricing, delivery, and ordering information, please contact Maxim Direct at 1-888-629-4642, or visit Maxim Integrated's website at www.maximintegrated.com.

Maxim Integrated cannot assume responsibility for use of any circuitry other than circuitry entirely embodied in a Maxim Integrated product. No circuit patent licenses are implied. Maxim Integrated reserves the right to change the circuitry and specifications without notice at any time.



Стандарт Электрон Связь

Мы молодая и активно развивающаяся компания в области поставок электронных компонентов. Мы поставляем электронные компоненты отечественного и импортного производства напрямую от производителей и с крупнейших складов мира.

Благодаря сотрудничеству с мировыми поставщиками мы осуществляем комплексные и плановые поставки широчайшего спектра электронных компонентов.

Собственная эффективная логистика и склад в обеспечивает надежную поставку продукции в точно указанные сроки по всей России.

Мы осуществляем техническую поддержку нашим клиентам и предпродажную проверку качества продукции. На все поставляемые продукты мы предоставляем гарантию .

Осуществляем поставки продукции под контролем ВП МО РФ на предприятия военно-промышленного комплекса России , а также работаем в рамках 275 ФЗ с открытием отдельных счетов в уполномоченном банке. Система менеджмента качества компании соответствует требованиям ГОСТ ISO 9001.

Минимальные сроки поставки, гибкие цены, неограниченный ассортимент и индивидуальный подход к клиентам являются основой для выстраивания долгосрочного и эффективного сотрудничества с предприятиями радиоэлектронной промышленности, предприятиями ВПК и научно-исследовательскими институтами России.

С нами вы становитесь еще успешнее!

Наши контакты:

Телефон: +7 812 627 14 35

Электронная почта: sales@st-electron.ru

Адрес: 198099, Санкт-Петербург,
Промышленная ул, дом № 19, литера Н,
помещение 100-Н Офис 331