

DESCRIPTION

The MP26056 is a linear, high performance single cell Li-Ion or Li-Polymer battery charger with dual programmable constant current set. By integrating high voltage input protection into the charger IC, the MP26056 can tolerate an input surge up to 28V.

The device features constant current (CC) and constant voltage (CV) charging modes, reverse current blocking and trickle charge. Other features include the programmable battery full threshold supporting dual AC/USB input by automatically changing to a lower charge current when the USB is the power supply. The MP26056 also provides ACOK and charge status indications to the system.

For guaranteed safe operation, the MP26056 limits the die temperature to a preset value when the device is heated up due to limited PCB space. Other safety features include battery temperature monitoring and programmable timer to prevent prolonged charging a dead battery.

MP26056 is available in 10-pin 3mm x 3mm QFN packages.

FEATURES

- Complete Solution for Charging Single-Cell Lion-Ion Battery
- Input Surge Up to 28V
- Dual USB/AC-Adapter Input with Auto Charge-Current Control
- Wide input operating range 3.5V to 6.5V
- 7V Input Over-Voltage Protection
- Programmable Charge Current: 200mA to 1A
- 80 μ A Idle Current with USB Input
- 0.75% V_{BATT} Accuracy over Temperature
- <1 μ A Battery Reverse Current
- Automatic die temperature limiting
- Fault and Charge Status Indicators
- Internal Soft-Start to limit inrush current
- Tiny 3mm x 3mm QFN Package

APPLICATIONS

- Cell Phones
- Digital Cameras
- Smart Phones
- PDAs
- MP3 Players

"MPS" and "The Future of Analog IC Technology" are Registered Trademarks of Monolithic Power Systems, Inc.

TYPICAL APPLICATION

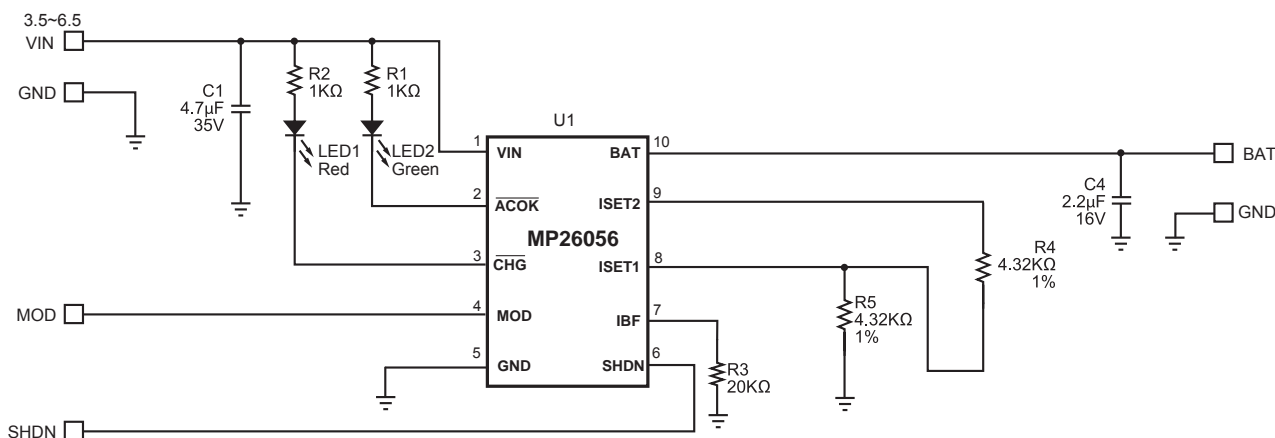

PACKAGE REFERENCE

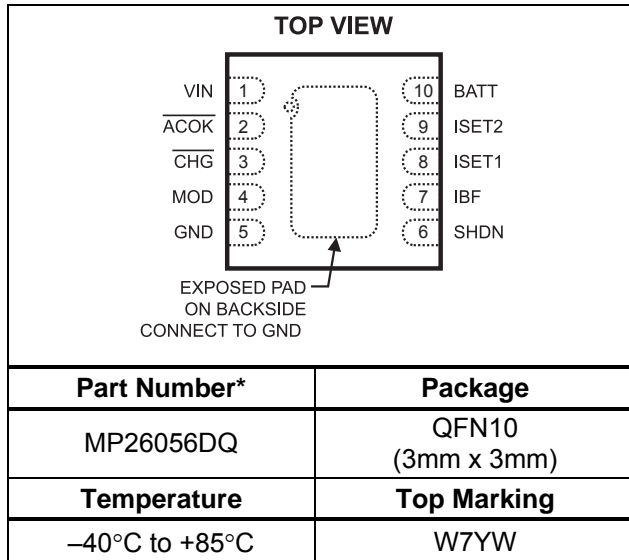

* For Tape & Reel, add suffix -Z (e.g. MP26056DQ-Z)
 For RoHS compliant packaging, add suffix -LF
 (e.g. MP26056DQ-LF-Z)

ABSOLUTE MAXIMUM RATINGS ⁽¹⁾

IN to GND -0.3V to +28V
 ACOK & CHG Maximum Sink current.....25mA
 All Other Pins to GND.....-0.3V to +6.5V
 Junction Temperature..... 140°C
 Lead Temperature260°C
 Storage Temperature-65°C to +150°C

Recommended Operating Conditions ⁽²⁾

Nominal Supply Voltage V_{IN} 3.5V to 5.5V
 Operating Temperature-40°C to +85°C

Thermal Resistance ⁽³⁾ θ_{JA} θ_{JC}
 3x3 QFN10 50 12... °C/W

Notes:

- 1) Exceeding these ratings may damage the device.
- 2) The device is not guaranteed to function outside of its operating conditions.
- 3) Measured on JEDEC51-7 4 layer board.

ELECTRICAL CHARACTERISTICS

$V_{IN} = 5V$, $V_{EN} = 0V$, $T_A = +25^\circ C$, unless otherwise noted.

Parameter	Symbol	Condition	Min	Typ	Max	Units
Idle Current	I_{SUPPLY}	MOD = High, SHDN = Low, $I_{CHG} = 0A$		80		μA
		MOD = LOW, SHDN = Low, $I_{CHG} = 0A$		500		
Input Over-Voltage Protection	OVP	V_{IN} Rise	6.8	7.0	7.2	V
OVP Hysteresis				400		mV
Battery Voltage Regulation	V_{BATT}	$T = -5^\circ C$ to $+75^\circ C$, $I_{BATT} = 0$	4.16	4.20	4.24	V
AC Constant Current Regulation	I_{CHG}	$V_{IN} = 5V$, $V_{BATT} = 3.8V$ $R_{ISET1} = R_{ISET2} = 3.2k\Omega$, MOD=LOW	475	525	585	mA
USB Constant Current Regulation	I_{CHG}	$V_{IN} = 5V$, $V_{BATT} = 3.8V$ $R_{ISET1} = R_{ISET2} = 3.2k\Omega$, MOD=HIGH	246	268	297	mA
Constant Current Variation		$V_{IN} = 5V$, $V_{BATT} = 3.8V$, $T_J = 0^\circ C$ to $+120^\circ C$, $I_{CHG} = 0.2A - 1A$	87	100	113	$\%I_{CHG}$ ⁽⁴⁾

ELECTRICAL CHARACTERISTICS *(continued)*
 $V_{IN} = 5V$, $V_{EN} = 0V$, $T_A = +25^{\circ}C$, unless otherwise noted.

Parameter	Symbol	Condition	Min	Typ	Max	Units
Battery Full Programming Range	I_{BF}	Refer to Operation section for programming I_{BF}	10		50	$\%I_{CHG}^{(4)}$
IBF Accuracy			75		125	$\%I_{BF}^{(5)}$
Input \overline{ACOK} Up Range		Input rising	6.7	7	7.3	V
Input \overline{ACOK} Up Range Hysteresis				400		mV
Input \overline{ACOK} Low Range		Input rising	1.5	2	2.5	V
Input \overline{ACOK} Low Range Hysteresis				200		mV
Protection Error Voltage	V_Z			8.2		V
SHDN Trip Threshold High			2.6			V
SHDN Trip Threshold Low					0.4	V
Mod Trip Threshold, High			2.6			V
Mod Trip Threshold, Low					0.4	V
\overline{CHG} , \overline{ACOK} Sink Current		Pin Voltage = 0.4V	8			mA
Battery Reverse Current to BATT Pin		SHDN = Low and Input = Floating or 0V			1	μA
Dropout Voltage	$V_{IN}-V_{BATT}$	$V_{BATT} = 3.8V$, $R_{CHG} = 6k\Omega$. Current drop 10%		0.25		V
Recharge Threshold Voltage	$V_{RECHARGE}$		3.9	4.0	4.1	V
Soft Thermal Shutdown Threshold			105	120	135	$^{\circ}C$
Soft Thermal Shutdown Hysteresis				10		$^{\circ}C$
Internal Soft-Start Time		From trickle to 90% of full current		10		ms

Notes:

 4) I_{CHG} is the target preprogrammed charge current (Die temperature below $110^{\circ}C$).

 5) I_{BF} is the target preprogrammed battery full current threshold

PIN FUNCTIONS

Pin #	Name	Description
1	IN	Input Supply Pin. IN receives the AC adapter or USB supply voltage.
2	$\overline{\text{ACOK}}$	Open-Drain OVP Indicator. This pin is low when $3.5\text{V} < V_{\text{IN}} < 6.5\text{V}$.
3	$\overline{\text{CHG}}$	Open-Drain Charge Indicator. This pin is low during charging, is High after battery full or termination,
4	MOD	USB input enable pin. Active High. Used to reduce charge current when USB is the supply.
5	GND, Exposed Pad	Ground. Exposed Pad must be connected to GND plane.
6	SHDN	Charger IC Enable. An input "Low" signal at this pin or if the pin is floating will enable the IC. An input "High" will disable the IC.
7	IBF	Charge Status Threshold Program. Connect this pin to an external resistor to program the charge termination current or battery full indication threshold. $I_{\text{BF}}=1.7/\text{Rbf}$
8	ISET1	USB Constant Charge Current Program pin. Connect this pin to an external resistor to program the charging current in CC Mode. $I_{\text{CHG}}=1.7/\text{Rset1}$ when Mod=HIGH
9	ISET2	Additional Constant Charge Current Program pin for AC input. Connect this pin to an external resistor to program the charging current in AC Mode. $I_{\text{CHG}} = 1.7/(\text{Rset1} // \text{Rset2})$ when Mod=LOW
10	BATT	Charger Output.

TYPICAL PERFORMANCE CURVES

$C_{IN}=4.7\mu F$, $C_{OUT}=2.2\mu F$, $V_{IN}=5V$, $T_A=25^\circ C$, unless otherwise noted.

AC Adapter Input Charge Curve

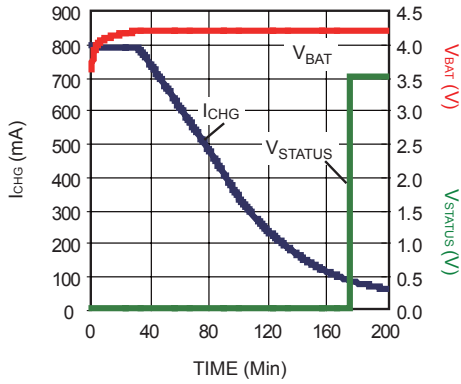

USB Input Charge Curve

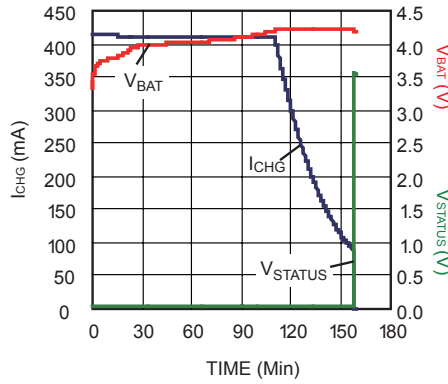

Constant Voltage Charge

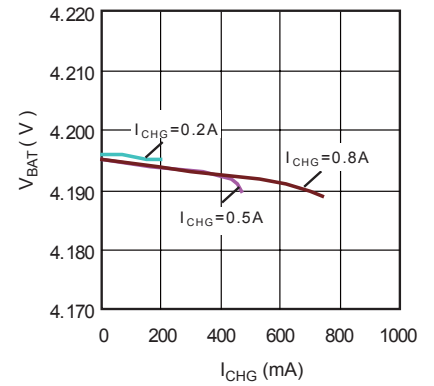

I_V Charge Curve

$V_{IN} = 5V$

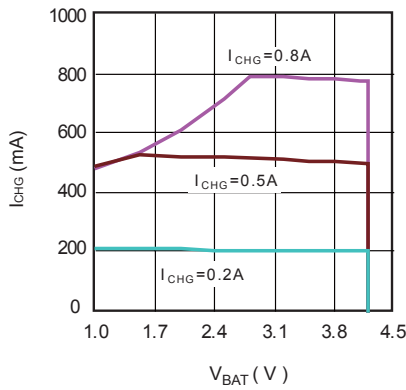

Constant Current Charge

$V_{BAT} = 3.8V$

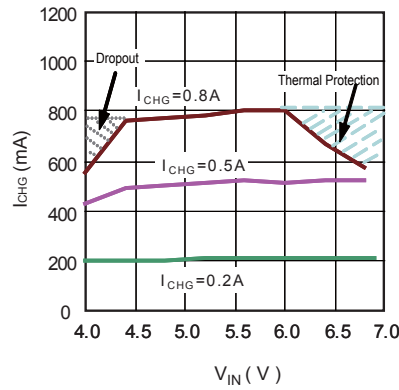

Battery Sink Current

$V_{IN} = GND$

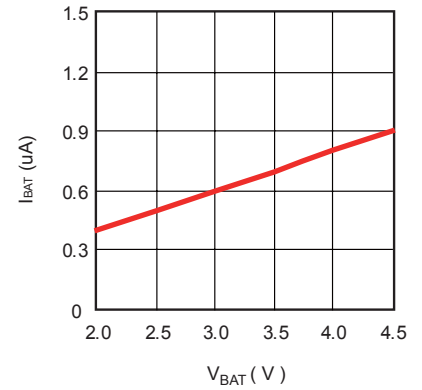

Shut Down Current

$V_{SHDN}=2.8V$

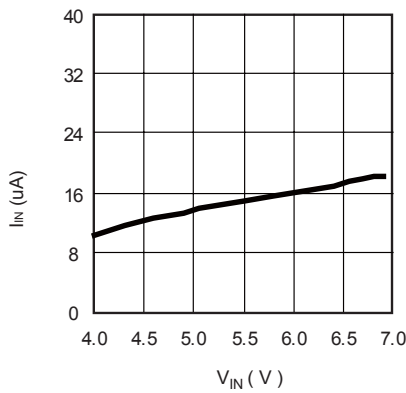

R_{SET} Resistance vs. I_{SET}

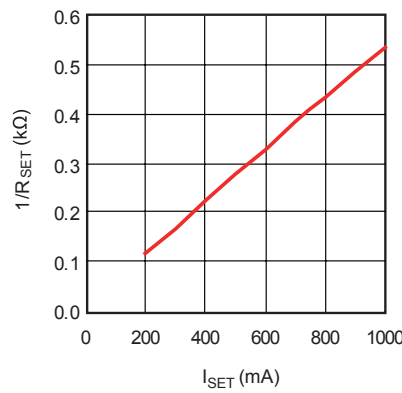

TYPICAL PERFORMANCE CURVES (continued)
 $C_{IN}=4.7\mu F, C_{OUT}=2.2\mu F, V_{IN}=5V, T_A=25^\circ C$, unless otherwise noted.

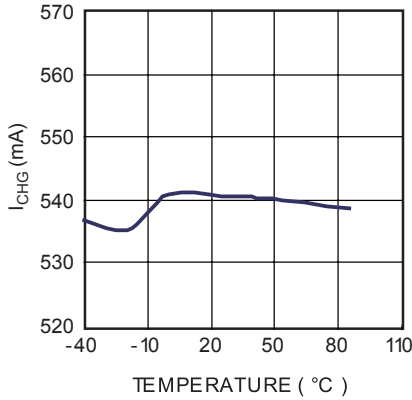
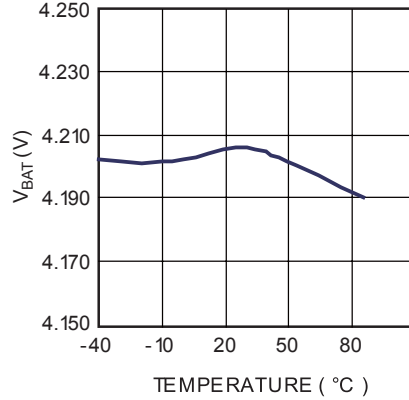
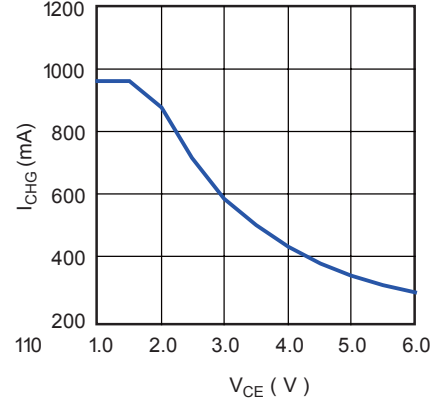
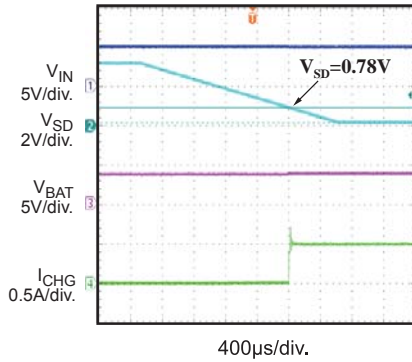
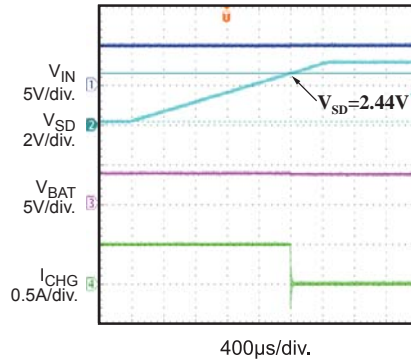
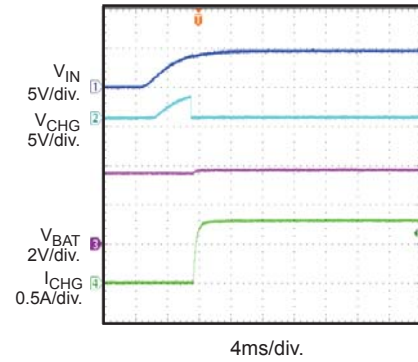
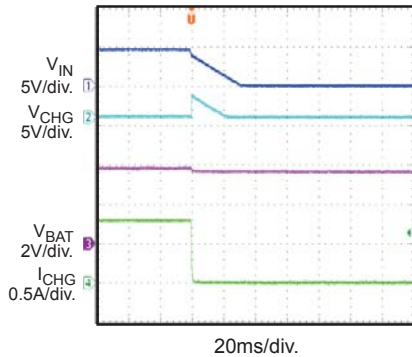
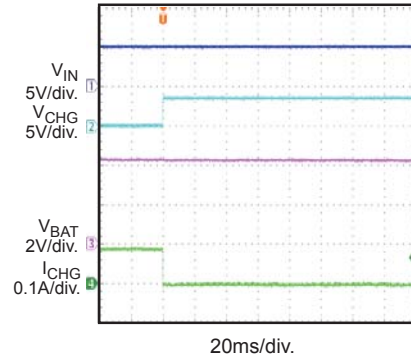
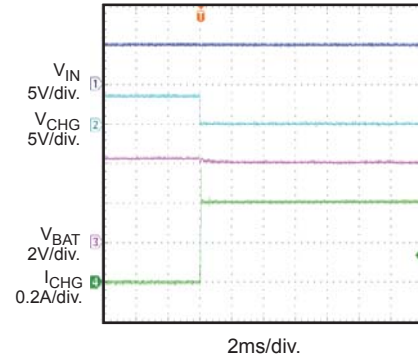
Constant Current Charge vs. Temp
 $V_{IN}=5V, V_{BAT}=3.8V, R_{SET}=3.3K\Omega$

Constant Voltage Charge vs. Temp
 $V_{IN}=5V, I_{CHG}=60mA$

Thermal Protection
 $V_{CE}=V_{IN}-V_{BAT}$

Shut Down Low
 $V_{IN}=5V, I_{SET} \text{ Resistor}=3.6K\Omega$

Shut Down High
 $V_{IN}=5V, I_{SET} \text{ Resistor}=3.6K\Omega$

Power Ramp Up
 $V_{IN}=5V, R_{SET}=2.26K\Omega$

Power Ramp Down
 $V_{IN}=5V, R_{SET}=2.26K\Omega$

USB Charge Full Terminated
 $V_{IN}=5V, R_{BF}=20K\Omega, I_{CHG}=0.4A$

USB Terminated to Re-Charge
 $V_{IN}=5V, R_{BF}=20K\Omega, I_{CHG}=0.4A$

BLOCK DIAGRAM

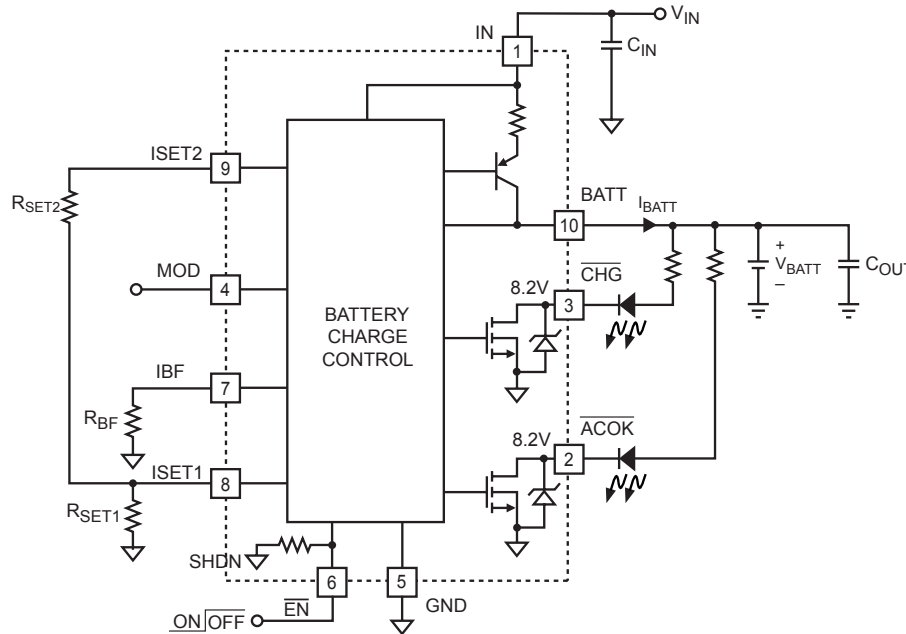

Figure 1—Functional Block Diagram

OPERATION

Input Voltage Range

The MP26056 has built-in input voltage surge protection as high as +28V. The charger IC will be automatically disabled when the input voltage is lower than 3.0 or higher than 7.0V. The open-drain pin ACOK is used to indicate an input power good condition (i.e. $3.5V < V_{IN} < 6.5V$). If the input voltage is lower than the battery voltage, the IC is also disabled to prevent the battery from draining.

Charge Cycle (Mode Change: CC to CV)

Figure 2 below shows the typical charging profile for the MP26056. The MP26056 will start with the Constant Current charge of the programmed value (I_{CHG}) based on R_{setx} . This is referred to as Constant Current (CC) mode. Once the battery voltage reaches 4.2V, the charger will operate in the constant voltage (CV) mode until the battery is fully charged. The charge current drops during CV mode, and the battery full indication is set when the charge current reduced to the preset value based on R_{IBF} , but the charger keeps charging the battery until battery reach 4.2V when AC adaptor is used as supply. If USB is

used as supply, please refer to the follow section for auto recharge operation.

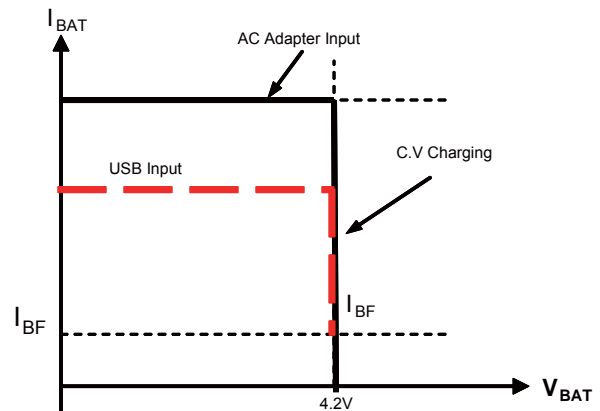

Figure 2—MP26056 Typical Charging Profile

Charge Status Indicator (CHG)

The MP26056 has an integrated charge status pin that remains low while the battery is charging. Once the charge current has reduced to the battery full charge current threshold (I_{BF}), the CHG pin will become high impedance. Under full charge conditions, certain systems

may draw a very narrow current pulse that exceeds the IBF threshold. The CHG indicator may glitch. It is desirable to blank the CHG glitch so that the system can properly indicate full charge conditions to the end user. A simple solution is to add a RC filter on the CHG pin to filter out the possible CHG glitch, as show in Figure 3.

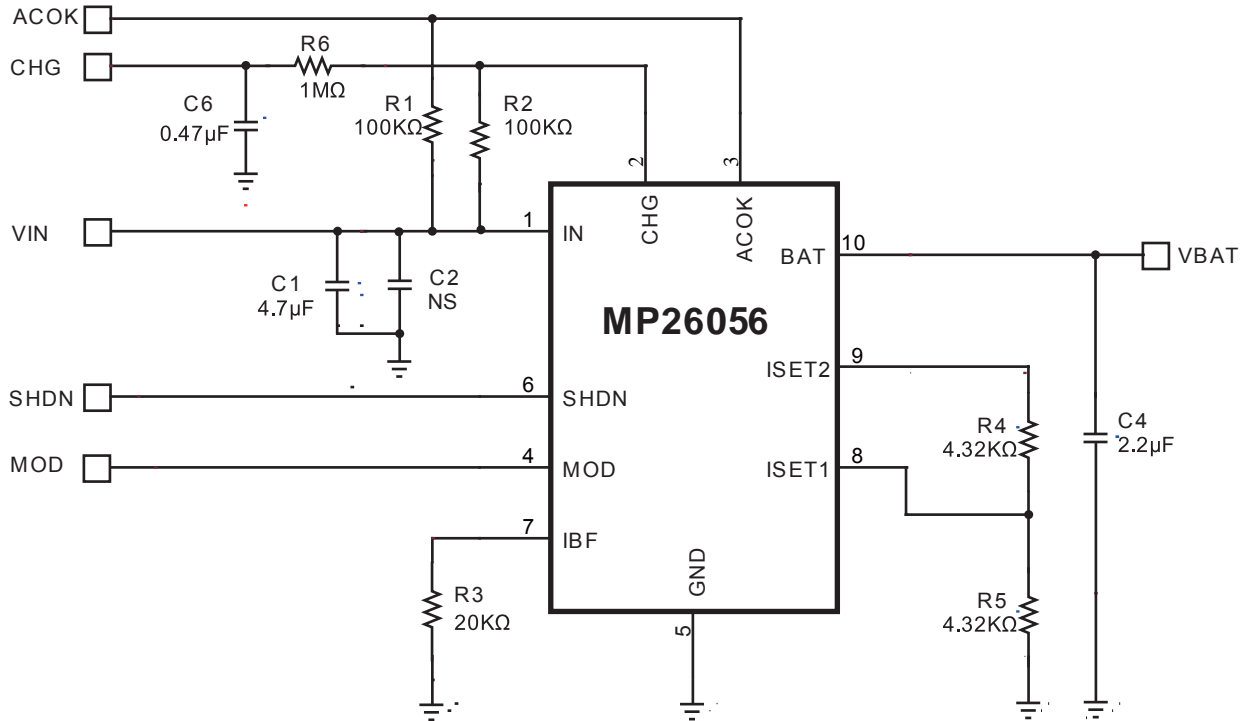

Figure 3—Filtered Charge Status with GPIO Connection

Charge termination in USB mode

The charge current will gradually decrease in CV mode as the battery approaches full. The battery full threshold can be programmed by connecting a resistor from IBF pin to ground. When the charge current reaches this threshold, the charger current will be turned off. The battery voltage may decay after termination due to self discharge or system draw current from the battery.

Automatic Recharge in USB mode

Upon V_{BATT} drops to 4.0V, the charger will automatically restart the charge cycle until the IBF condition is met again. When the input is unplugged or the charger is disabled and/or terminated, the leakage current from the battery to MP26056 is less than 1uA.

Programming of Charge Current and Battery Full Current

The charge current (I_{CHG}) is set by resistors (R_{SETX}) connecting from the I_{SETX} pin to GND. The relationship of the charge current and the programming resistance is established by following equations.

$$I_{CHG} = \frac{1A \times 1.7k\Omega}{R_{SET1}} \quad (\text{MOD= High, for USB})$$

$$I_{CHG} = \frac{1A \times 1.7k\Omega}{R_{SET1} // R_{SET2}} \quad (\text{MOD=Low, for AC Adapter})$$

It is highly recommended to program the charge current within 0.2A to 1A. The battery full charge current threshold (I_{BF}) is programmed by connecting a resistor R_{BF} from the IBF pin to GND:

$$I_{BF} = \frac{1A \times 1.7k\Omega}{R_{BF}}$$

The selection of R_{BF} value should meet the condition, $0.1I_{CHG} < I_{BF} < 0.6 I_{CHG}$. The open-drain

pin \overline{CHG} is used to indicate charging status. When the battery full condition is reached or any other condition prevents the charger from charging, \overline{CHG} will become a floating.

Thermal Protection

The MP26056 has proprietary thermal protection to prevent the IC from overheating. When in thermal protection mode, the charge current becomes a saw-tooth waveform instead of a DC current. The average current of the saw-tooth waveform will be lower than the programmed DC charge current to prevent the IC from overheating. Operating in thermal protection mode will slow down the charging process. Lowering the input voltage and enhancing thermal dissipation to the environment can effectively prevent the IC from going into thermal protection mode.

APPLICATION

MP26056 Flow Chart

Power-On Reset (POR) feature can be applied To the MP26056 to ensure that the device starts Operating in a known state. The flow chart in Figure 4 describes the conditions and operation

Modes of the MP26056 CVC and CCC stand for “constant voltage charge” and “constant current charge”, respectively.

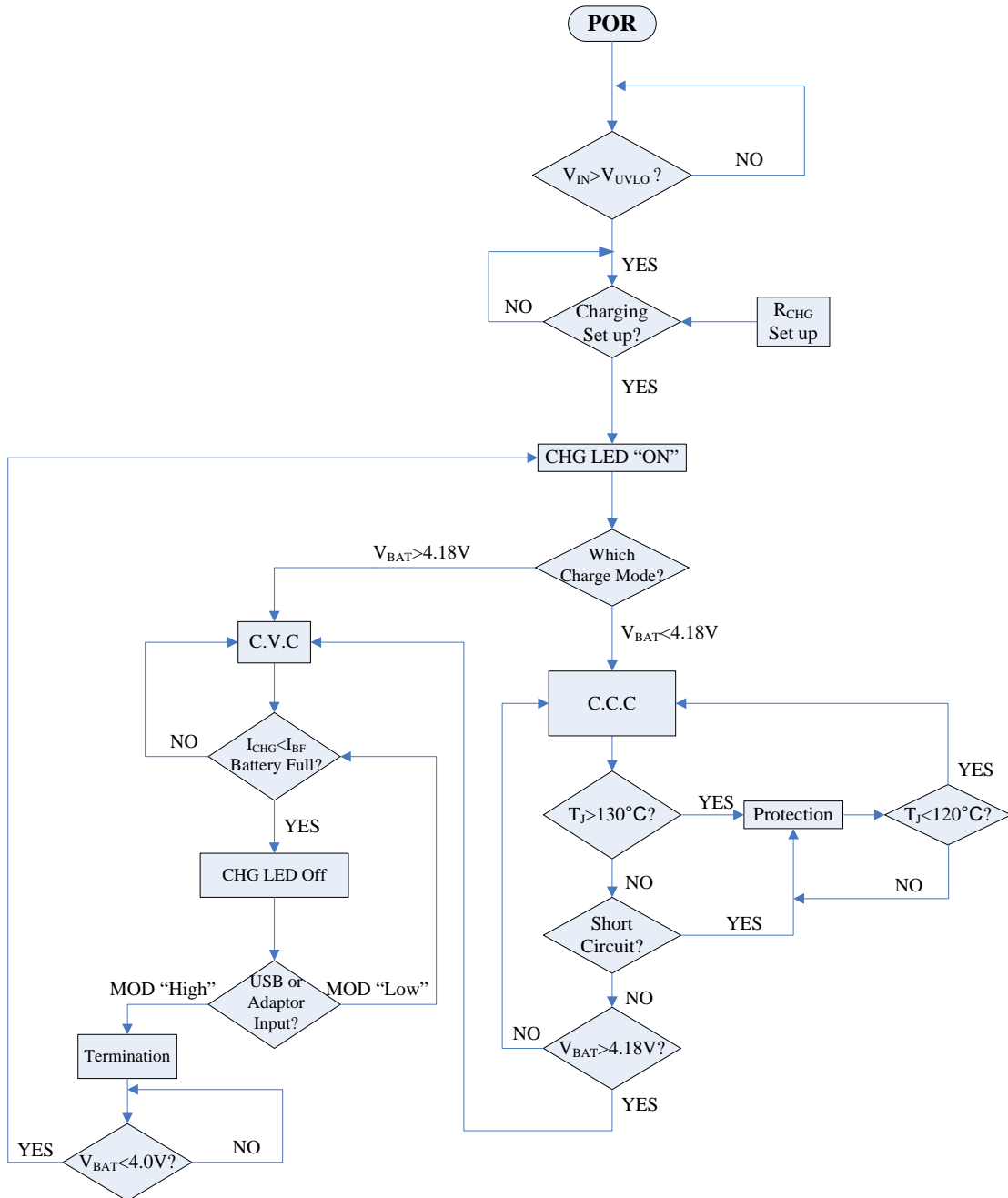
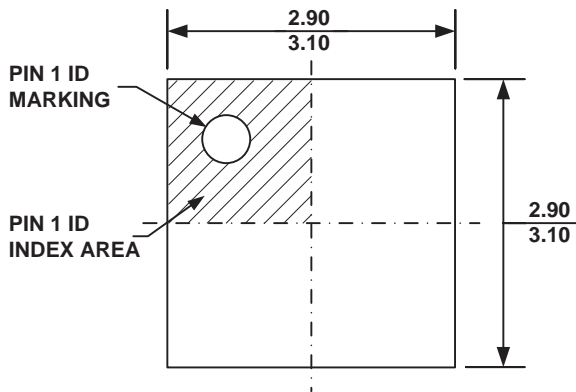

Figure 4-Operation Flow Chart

PACKAGE INFORMATION

QFN10 (3mm x 3mm)



TOP VIEW

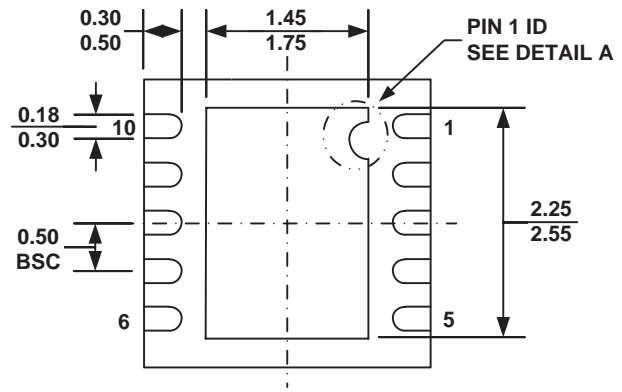

BOTTOM VIEW

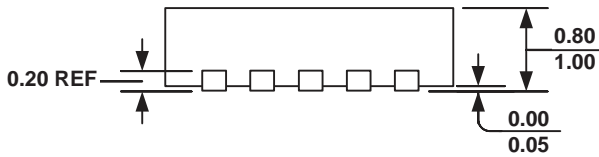

SIDE VIEW

**PIN 1 ID OPTION A
R0.20 TYP.**

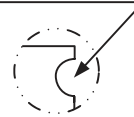

**PIN 1 ID OPTION B
R0.20 TYP.**

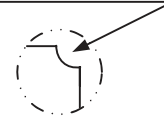

DETAIL A

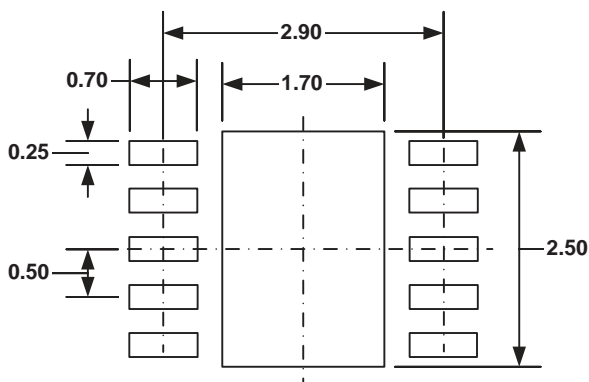

RECOMMENDED LAND PATTERN

NOTE:

- 1) ALL DIMENSIONS ARE IN MILLIMETERS.
- 2) EXPOSED PADDLE SIZE DOES NOT INCLUDE MOLD FLASH.
- 3) LEAD COPLANARITY SHALL BE 0.10 MILLIMETER MAX.
- 4) DRAWING CONFORMS TO JEDEC MO-229, VARIATION VEEED-5.
- 5) DRAWING IS NOT TO SCALE.

NOTICE: The information in this document is subject to change without notice. Users should warrant and guarantee that third party Intellectual Property rights are not infringed upon when integrating MPS products into any application. MPS will not assume any legal responsibility for any said applications.



**Стандарт
Электрон
Связь**

Мы молодая и активно развивающаяся компания в области поставок электронных компонентов. Мы поставляем электронные компоненты отечественного и импортного производства напрямую от производителей и с крупнейших складов мира.

Благодаря сотрудничеству с мировыми поставщиками мы осуществляем комплексные и плановые поставки широчайшего спектра электронных компонентов.

Собственная эффективная логистика и склад в обеспечивает надежную поставку продукции в точно указанные сроки по всей России.

Мы осуществляем техническую поддержку нашим клиентам и предпродажную проверку качества продукции. На все поставляемые продукты мы предоставляем гарантию .

Осуществляем поставки продукции под контролем ВП МО РФ на предприятия военно-промышленного комплекса России , а также работаем в рамках 275 ФЗ с открытием отдельных счетов в уполномоченном банке. Система менеджмента качества компании соответствует требованиям ГОСТ ISO 9001.

Минимальные сроки поставки, гибкие цены, неограниченный ассортимент и индивидуальный подход к клиентам являются основой для выстраивания долгосрочного и эффективного сотрудничества с предприятиями радиоэлектронной промышленности, предприятиями ВПК и научно-исследовательскими институтами России.

С нами вы становитесь еще успешнее!

Наши контакты:

Телефон: +7 812 627 14 35

Электронная почта: sales@st-electron.ru

Адрес: 198099, Санкт-Петербург,
Промышленная ул, дом № 19, литера Н,
помещение 100-Н Офис 331