

# PS9123

## Data Sheet

R08DS0030EJ0100

Rev.1.00

HIGH CMR, 15 Mbps TOTEM POLE OUTPUT TYPE, 5-PIN SOP (SO-5) PHOTOCOUPLER

Aug 14, 2012

### DESCRIPTION

The PS9123 is an optically coupled high-speed, totem pole output isolator containing a GaAlAs LED on the input side and a photodiode and a signal processing circuit on the output side on one chip.

The PS9123 is specified high CMR, high CTR and pulse width distortion with operating temperature.

### <R> FEATURES

- High common mode transient immunity ( $CM_H, CM_L = \pm 20 \text{ kV}/\mu\text{s}$  TYP.)
- Small package (SO-5)
- Pulse width distortion ( $|t_{PHL} - t_{PLH}| = 4 \text{ ns}$  TYP.)
- High-speed (15 Mbps)
- High isolation voltage ( $BV = 3\,750 \text{ V r.m.s.}$ )
- Totem pole output
- Embossed tape product : PS9123-F3 : 2 500 pcs/reel
- Pb-Free product
- Safety standards
  - UL approved: File No. E72422
  - CSA approved: No. CA 101391 (CA5A, CAN/CSA-C22.2 60065, 60950)
  - DIN EN60747-5-5 (VDE0884-5): 2011-11 approved No. 40008902 (Option)

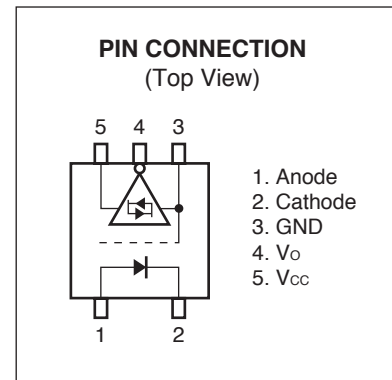

### TRUTH TABLE

LED	Output
ON	L
OFF	H

### APPLICATIONS

- PLC
- Inverter
- AC servo

The mark <R> shows major revised points.

The revised points can be easily searched by copying an "<R>" in the PDF file and specifying it in the "Find what:" field.

<R> **PACKAGE DIMENSIONS (UNIT: mm)**

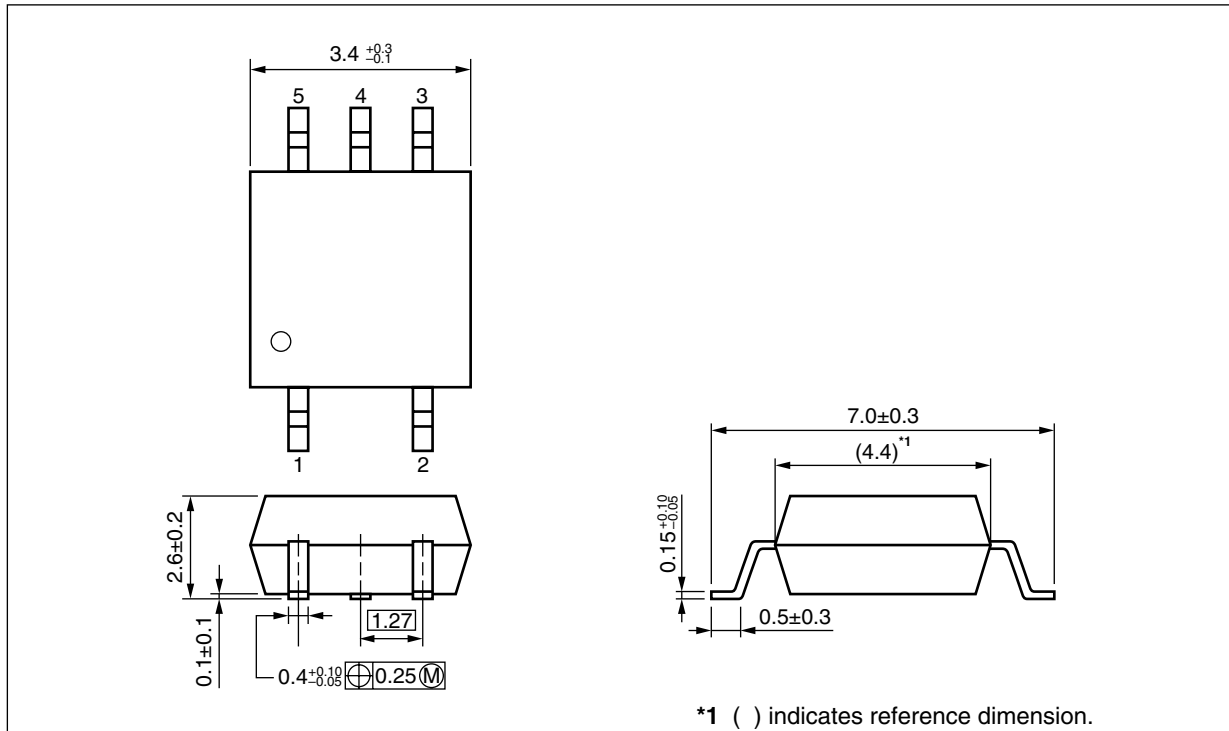

<R> **PHOTOCOPLER CONSTRUCTION**

Parameter	Unit (MIN.)
Air Distance	4.2 mm
Outer Creepage Distance	4.2 mm
Isolation Distance	0.2 mm

<R> **MARKING EXAMPLE**

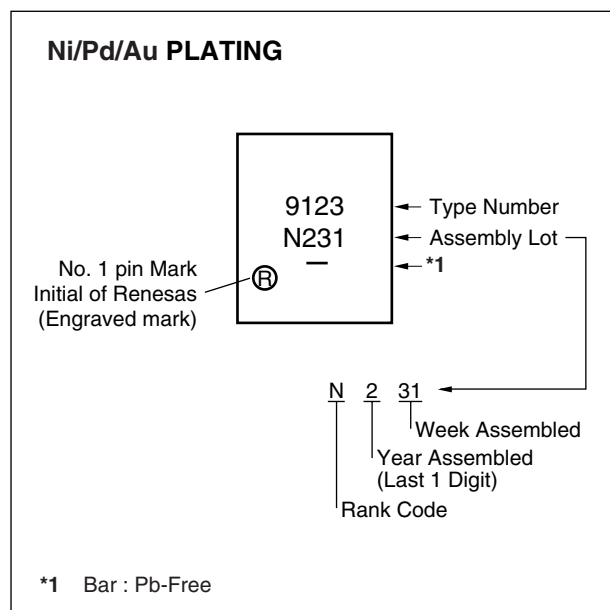

<R> **ORDERING INFORMATION**

Part Number	Order Number	Solder Plating Specification	Packing Style	Safety Standard Approval	Application Part Number <sup>*1</sup>
PS9123	PS9123-AX	Pb-Free (Ni/Pd/Au)	20 pcs (Tape 20 pcs cut)	Standard products (UL, CSA approved)	PS9123
PS9123-F3	PS9123-F3-AX		Embossed Tape 2 500 pcs/reel		
PS9123-V	PS9123-V-AX		20 pcs (Tape 20 pcs cut)	DIN EN60747-5-5 (VDE0884-5): 2011-11 Approved (Option)	
PS9123-V-F3	PS9123-V-F3-AX		Embossed Tape 2 500 pcs/reel		

Note: \*1. For the application of the Safety Standard, following part number should be used.

<R> **ABSOLUTE MAXIMUM RATINGS (T<sub>A</sub> = 25°C, unless otherwise specified)**

Parameter		Symbol	Ratings	Unit
Diode	Forward Current <sup>*1</sup>	I <sub>F</sub>	20	mA
	Reverse Voltage	V <sub>R</sub>	5	V
Detector	Supply Voltage	V <sub>CC</sub>	7	V
	Output Voltage	V <sub>O</sub>	7	V
	High Level Output Current	I <sub>OH</sub>	-5	mA
	Low Level Output Current	I <sub>OL</sub>	13	mA
	Power Dissipation <sup>*2</sup>	P <sub>C</sub>	130	mW
Isolation Voltage <sup>*3</sup>		BV	3 750	Vr.m.s.
Operating Ambient Temperature		T <sub>A</sub>	-40 to +100	°C
Storage Temperature		T <sub>stg</sub>	-55 to +125	°C

Notes: \*1. Reduced to 0.19 mA/°C at T<sub>A</sub> = 60°C or more.

\*2. T<sub>A</sub> = -40 to +100°C, applies to output pin V<sub>O</sub> and power supply pin V<sub>CC</sub>. Reduced to 2.4 mW/°C at T<sub>A</sub> = 70°C or more.

\*3. AC voltage for 1 minute at T<sub>A</sub> = 25°C, RH = 60% between input and output.  
Pins 1-2 shorted together, 3-5 shorted together.

<R> **RECOMMENDED OPERATING CONDITIONS**

Parameter	Symbol	MIN.	TYP.	MAX.	Unit
High Level Input Current	I <sub>FH</sub>	7.5		12.5	mA
Low Level Input Voltage	V <sub>FL</sub>	0		0.8	V
Supply Voltage	V <sub>CC</sub>	4.5	5.0	5.5	V
TTL (loads)	N			3	

<R> **ELECTRICAL CHARACTERISTICS ( $T_A = -40$  to  $+100^\circ\text{C}$ , unless otherwise specified)**

	Parameter	Symbol	Conditions	MIN.	TYP.*1	MAX.	Unit
Diode	Forward Voltage	$V_F$	$I_F = 10 \text{ mA}$ , $T_A = 25^\circ\text{C}$	1.3	1.55	1.8	V
	Reverse Current	$I_R$	$V_R = 3 \text{ V}$ , $T_A = 25^\circ\text{C}$			10	$\mu\text{A}$
	Terminal Capacitance	$C_t$	$f = 1 \text{ MHz}$ , $V_F = 0 \text{ V}$ , $T_A = 25^\circ\text{C}$		30		pF
Detector	High Level Output Current	$I_{OH}$	$V_{CC} = V_O = 5.5 \text{ V}$ , $I_F = 0 \text{ mA}$		0.05	100	$\mu\text{A}$
	High Level Output Voltage	$V_{OH}$	$V_{CC} = 4.5 \text{ V}$ , $I_F = 0 \text{ mA}$ , $I_{OH} = -2 \text{ mA}$	2.4	3.0		V
	Low Level Output Voltage	$V_{OL}$	$V_{CC} = 4.5 \text{ V}$ , $I_F = 7 \text{ mA}$ , $I_{OL} = 8 \text{ mA}$		0.25	0.6	V
	High Level Supply Current	$I_{CCH}$	$V_{CC} = 5.5 \text{ V}$ , $I_F = 0 \text{ mA}$ , $V_O = \text{open}$		4	7	mA
	Low Level Supply Current	$I_{CCL}$	$V_{CC} = 5.5 \text{ V}$ , $I_F = 10 \text{ mA}$ , $V_O = \text{open}$		6	10	mA
	High Level Output Short Circuit Current	$I_{OSH}$	$V_{CC} = 5.5 \text{ V}$ , $V_O = \text{GND}$ , $I_F = 0 \text{ mA}$ , 10 ms or less		-43		mA
	Low Level Output Short Circuit Current	$I_{OSL}$	$V_{CC} = V_O = 5.5 \text{ V}$ , $I_F = 8 \text{ mA}$ , 10 ms or less		28		mA
Coupled	Threshold Input Voltage (H $\rightarrow$ L)	$I_{FHL}$	$V_{CC} = 5 \text{ V}$ , $V_O = 0.6 \text{ V}$		2.3	5	mA
	Isolation Resistance	$R_{I-O}$	$V_{I-O} = 1 \text{ kV}_{DC}$ , $RH = 40$ to $60\%$ , $T_A = 25^\circ\text{C}$	$10^{11}$			$\Omega$
	Isolation Capacitance	$C_{I-O}$	$V = 0 \text{ V}$ , $f = 1 \text{ MHz}$ , $T_A = 25^\circ\text{C}$		0.6		pF
	Propagation Delay Time (H $\rightarrow$ L) <sup>*2</sup>	$t_{PHL}$	$V_{CC} = 5 \text{ V}$ , $I_F = 7.5 \text{ mA}$	10	28	60	ns
	Propagation Delay Time (L $\rightarrow$ H) <sup>*2</sup>	$t_{PLH}$	$V_{CC} = 5 \text{ V}$ , $I_F = 7.5 \text{ mA}$	10	32	60	ns
	Pulse Width Distortion (PWD) <sup>*2</sup>	$ t_{PHL} - t_{PLH} $	$V_{CC} = 5 \text{ V}$ , $I_F = 7.5 \text{ mA}$		4	30	ns
	Common Mode Transient Immunity at High Level Output <sup>*3</sup>	$CM_H$	$V_{CC} = 5 \text{ V}$ , $T_A = 25^\circ\text{C}$ , $I_F = 0 \text{ mA}$ , $V_{O(MIN.)} = 2 \text{ V}$ , $V_{CM} = 1 \text{ kV}$	15	20		$\text{kV}/\mu\text{s}$
	Common Mode Transient Immunity at Low Level Output <sup>*3</sup>	$CM_L$	$V_{CC} = 5 \text{ V}$ , $T_A = 25^\circ\text{C}$ , $I_F = 7.5 \text{ mA}$ , $V_{O(MAX.)} = 0.8 \text{ V}$ , $V_{CM} = 1 \text{ kV}$	15	20		$\text{kV}/\mu\text{s}$

**PS9123**

Notes: \*1. Typical values at  $T_A = 25^\circ\text{C}$

\*2. Test circuit for propagation delay time

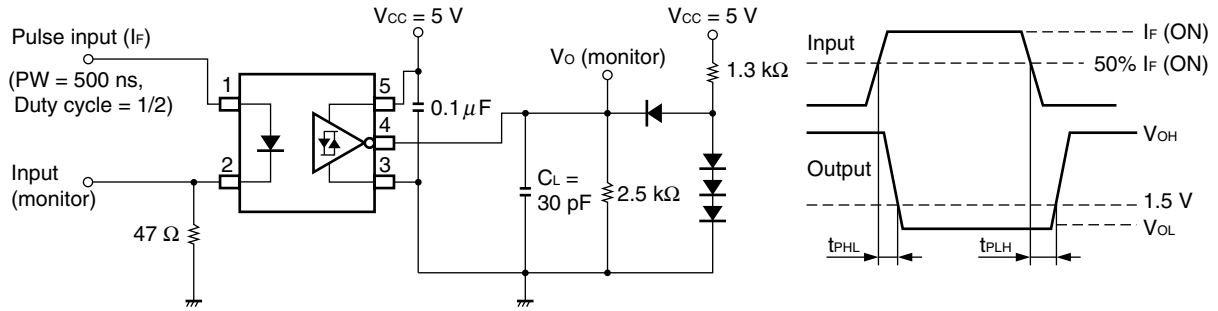

$C_L$  includes probe and stray wiring capacitance.

\*3. Test circuit for common mode transient immunity

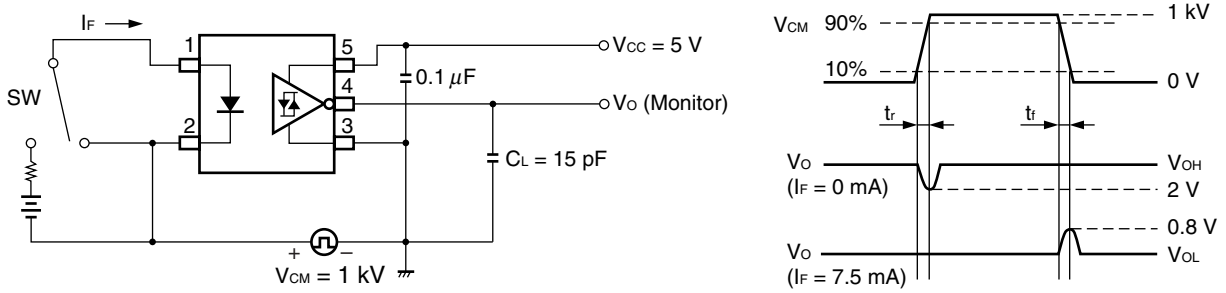

$C_L$  includes probe and stray wiring capacitance.

<R> **TYPICAL CHARACTERISTICS (T<sub>A</sub> = 25°C, unless otherwise specified)**

**MAXIMUM FORWARD CURRENT vs. AMBIENT TEMPERATURE**

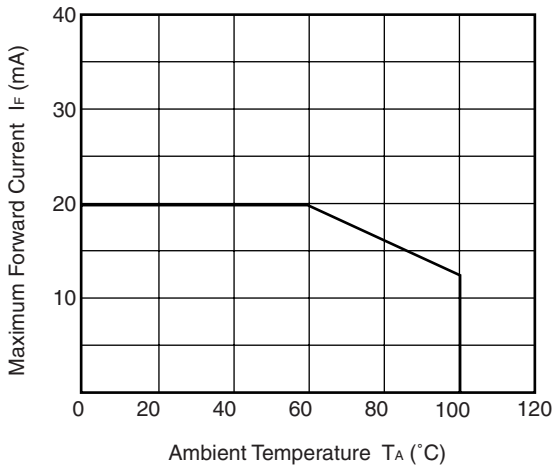

**DETECTOR POWER DISSIPATION vs. AMBIENT TEMPERATURE**

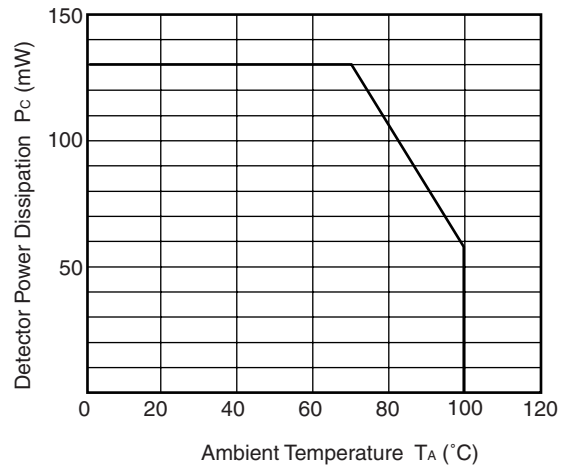

**FORWARD CURRENT vs. FORWARD VOLTAGE**

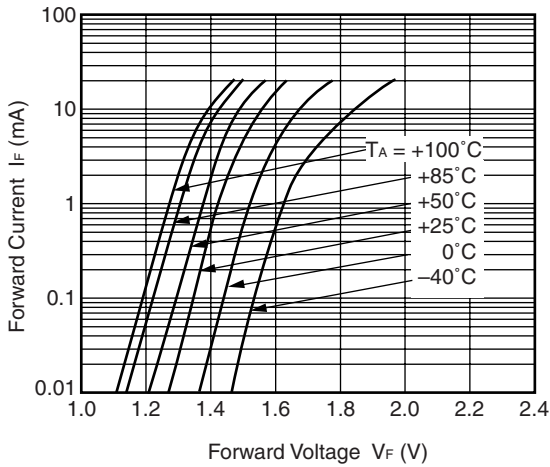

**SUPPLY CURRENT vs. AMBIENT TEMPERATURE**

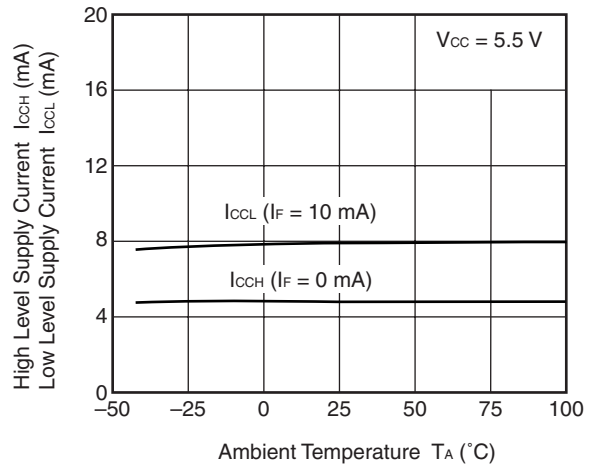

**HIGH LEVEL OUTPUT VOLTAGE vs. AMBIENT TEMPERATURE**

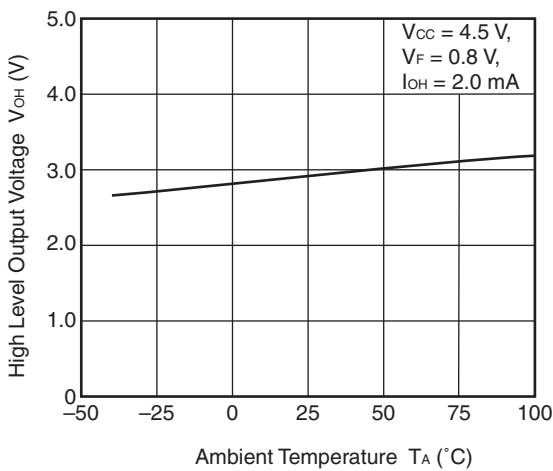

**PROPAGATION DELAY TIME, PULSE WIDTH DISTORTION vs. AMBIENT TEMPERATURE**

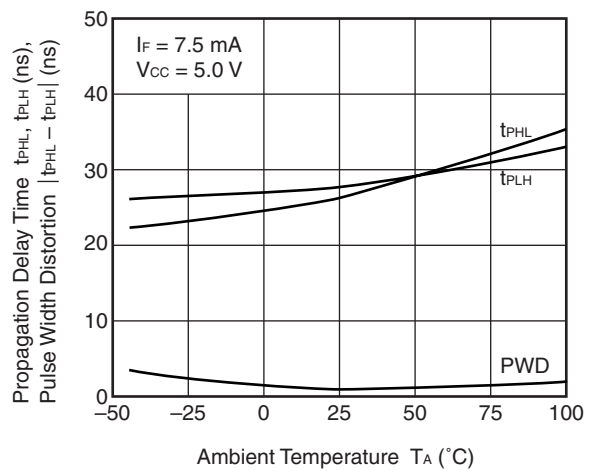

**Remark** The graphs indicate nominal characteristics.

**LOW LEVEL OUTPUT VOLTAGE vs. AMBIENT TEMPERATURE**

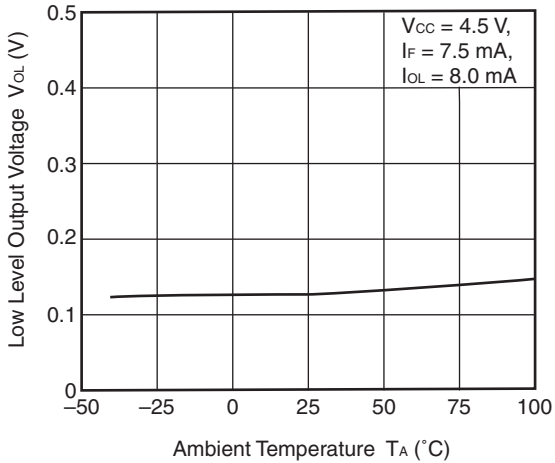

**THRESHOLD INPUT CURRENT vs. AMBIENT TEMPERATURE**

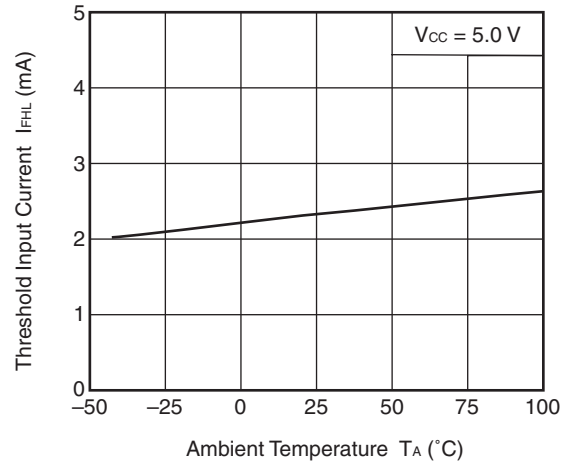

**LOW LEVEL OUTPUT VOLTAGE vs. LOW LEVEL OUTPUT CURRENT**

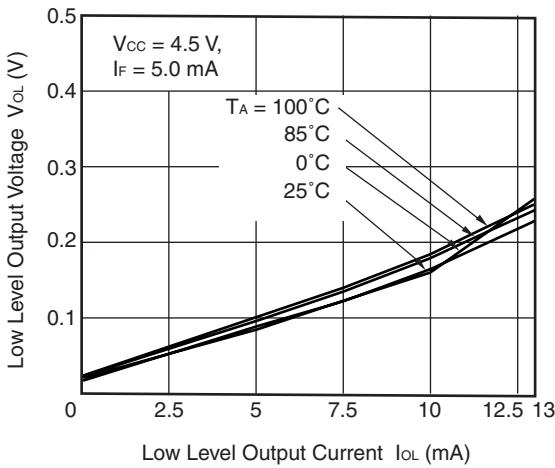

**HIGH LEVEL OUTPUT VOLTAGE vs. HIGH LEVEL OUTPUT CURRENT**

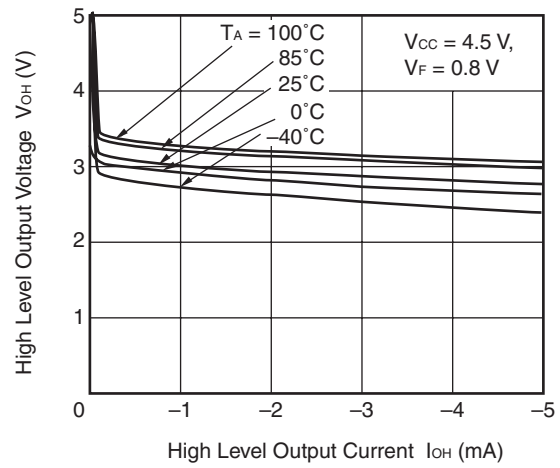

**HIGH LEVEL OUTPUT VOLTAGE vs. HIGH LEVEL OUTPUT CURRENT**

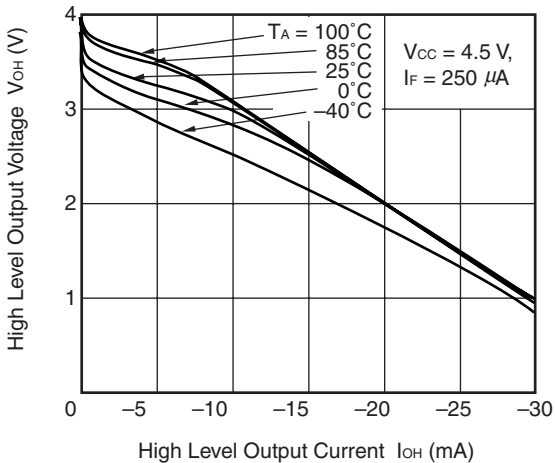

**PROPAGATION DELAY TIME, PULSE WIDTH DISTORTION vs. FORWARD CURRENT**

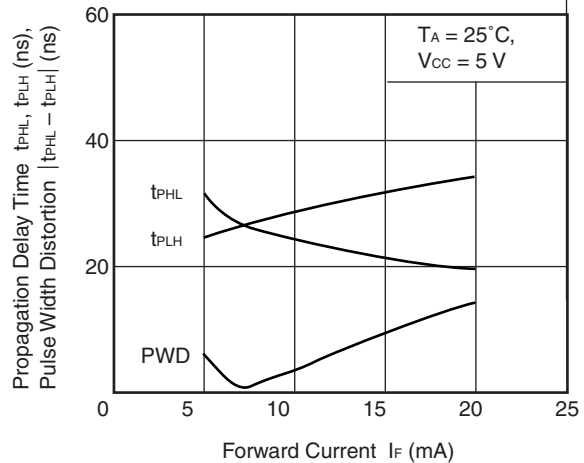

**Remark** The graphs indicate nominal characteristics.

<R> TAPING SPECIFICATIONS (UNIT: mm)

Outline and Dimensions (Tape)

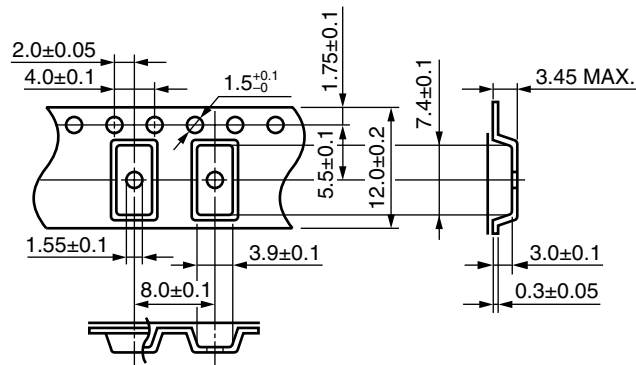

Tape Direction

PS9123-F3

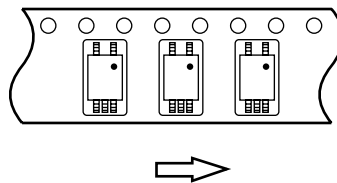

Outline and Dimensions (Reel)

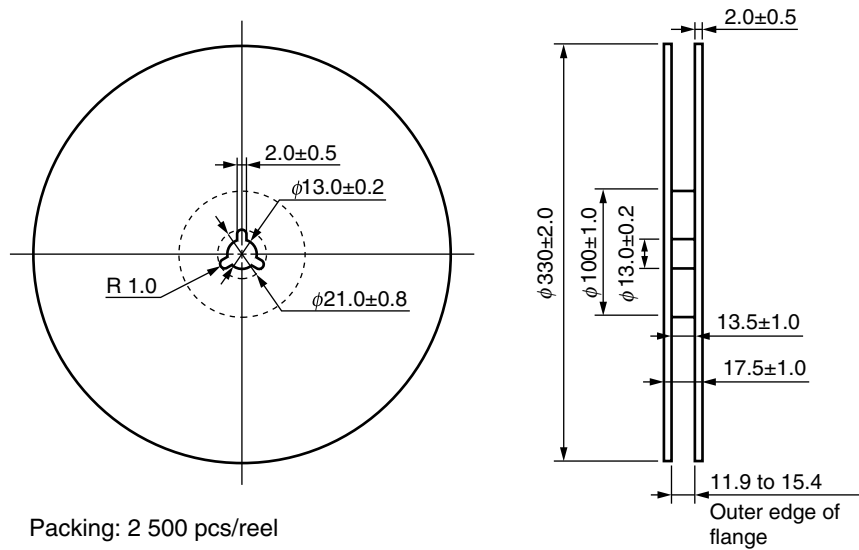

Packing: 2 500 pcs/reel



<R> **RECOMMENDED MOUNT PAD DIMENSIONS (UNIT: mm)**

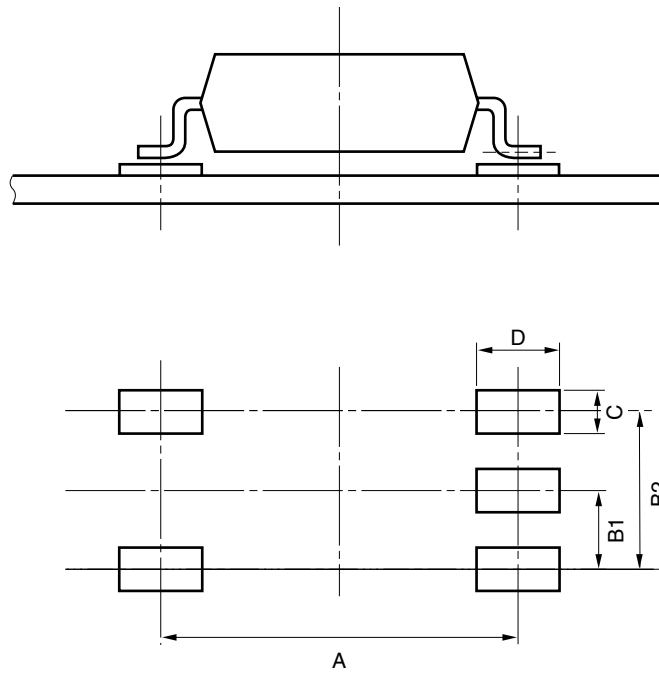

Part Number	A	B1	B2	C	D
PS9123	6.25	1.27	2.54	0.8	1.45

**NOTES ON HANDLING**

## 1. Recommended soldering conditions

## (1) Infrared reflow soldering

- Peak reflow temperature 260°C or below (package surface temperature)
- Time of peak reflow temperature 10 seconds or less
- Time of temperature higher than 220°C 60 seconds or less
- Time to preheat temperature from 120 to 180°C 120±30 s
- Number of reflows Three or less
- Flux Rosin flux containing small amount of chlorine (The flux with a maximum chlorine content of 0.2 Wt% or less is recommended.)

Recommended Temperature Profile of Infrared Reflow

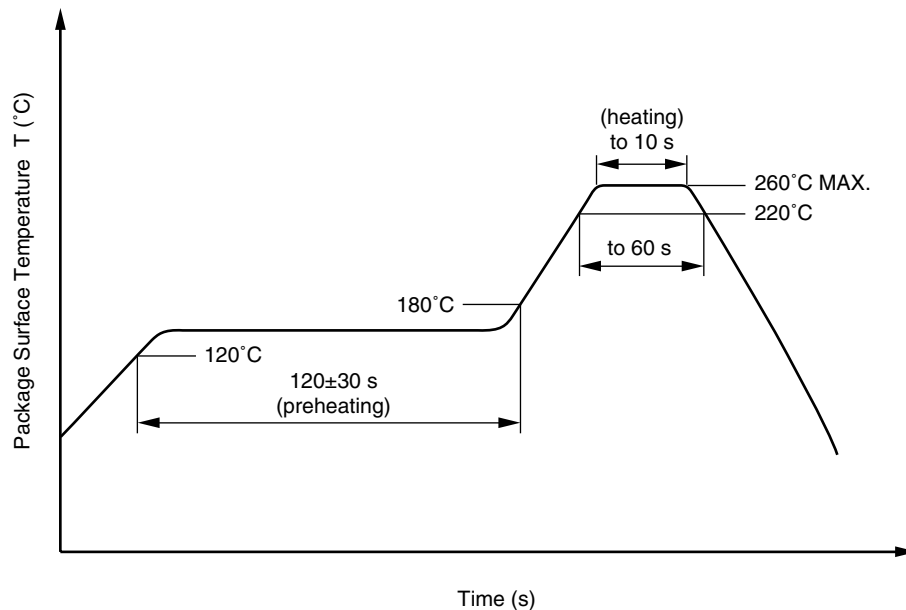

## (2) Wave soldering

- Temperature 260°C or below (molten solder temperature)
- Time 10 seconds or less
- Preheating conditions 120°C or below (package surface temperature)
- Number of times One (Allowed to be dipped in solder including plastic mold portion.)
- Flux Rosin flux containing small amount of chlorine (The flux with a maximum chlorine content of 0.2 Wt% or less is recommended.)

## (3) Soldering by Soldering Iron

- Peak Temperature (lead part temperature) 350°C or below
- Time (each pin) 3 seconds or less
- Flux Rosin flux containing small amount of chlorine (The flux with a maximum chlorine content of 0.2 Wt% or less is recommended.)

(a) Soldering of leads should be made at the point 1.5 to 2.0 mm from the root of the lead

## (4) Cautions

- Fluxes  
Avoid removing the residual flux with freon-based and chlorine-based cleaning solvent.

## 2. Cautions Regarding Noise

Be aware that when voltage is applied suddenly between the photocoupler's input and output at startup, the output transistor may enter the on state, even if the voltage is within the absolute maximum ratings.

**USAGE CAUTIONS**

1. This product is weak for static electricity by designed with high-speed integrated circuit so protect against static electricity when handling.
2. By-pass capacitor of 0.1  $\mu\text{F}$  or more is used between  $V_{\text{CC}}$  and GND near device. Also, ensure that the distance between the leads of the photocoupler and capacitor is 10 mm or less.
3. Avoid storage at a high temperature and high humidity.

## &lt;R&gt; SPECIFICATION OF VDE MARKS LICENSE DOCUMENT

Parameter	Symbol	Spec.	Unit
Climatic test class (IEC 60068-1/DIN EN 60068-1)		40/100/21	
Dielectric strength maximum operating isolation voltage	$U_{IORM}$	707	$V_{peak}$
Test voltage (partial discharge test, procedure a for type test and random test) $U_{pr} = 1.6 \times U_{IORM}, P_d < 5 \text{ pC}$	$U_{pr}$	1 131	$V_{peak}$
Test voltage (partial discharge test, procedure b for all devices) $U_{pr} = 1.875 \times U_{IORM}, P_d < 5 \text{ pC}$	$U_{pr}$	1 326	$V_{peak}$
Highest permissible overvoltage	$U_{TR}$	6 000	$V_{peak}$
Degree of pollution (DIN EN 60664-1 VDE0110 Part 1)		2	
Comparative tracking index (IEC 60112/DIN EN 60112 (VDE 0303 Part 1))	CTI	175	
Material group (DIN EN 60664-1 VDE0110 Part 1)		III a	
Storage temperature range	$T_{stg}$	-55 to +125	°C
Operating temperature range	$T_A$	-40 to +100	°C
Isolation resistance, minimum value $V_{IO} = 500 \text{ V dc at } T_A = 25^\circ\text{C}$ $V_{IO} = 500 \text{ V dc at } T_A \text{ MAX. at least } 100^\circ\text{C}$	Ris MIN. Ris MIN.	$10^{12}$ $10^{11}$	$\Omega$ $\Omega$
Safety maximum ratings (maximum permissible in case of fault, see thermal derating curve) Package temperature Current (input current $I_F, P_{si} = 0$ ) Power (output or total power dissipation) Isolation resistance $V_{IO} = 500 \text{ V dc at } T_A = T_{si}$	$T_{si}$ $I_{si}$ $P_{si}$ Ris MIN.	150 200 300 $10^9$	°C mA mW $\Omega$

<b>Caution</b> GaAs Products	<p>This product uses gallium arsenide (GaAs). GaAs vapor and powder are hazardous to human health if inhaled or ingested, so please observe the following points.</p> <ul style="list-style-type: none"><li>• Follow related laws and ordinances when disposing of the product. If there are no applicable laws and/or ordinances, dispose of the product as recommended below.<ol style="list-style-type: none"><li>1. Commission a disposal company able to (with a license to) collect, transport and dispose of materials that contain arsenic and other such industrial waste materials.</li><li>2. Exclude the product from general industrial waste and household garbage, and ensure that the product is controlled (as industrial waste subject to special control) up until final disposal.</li></ol></li><li>• Do not burn, destroy, cut, crush, or chemically dissolve the product.</li><li>• Do not lick the product or in any way allow it to enter the mouth.</li></ul>
------------------------------	--

**Revision History****PS9123 Data Sheet**

Rev.	Date	Description	
		Page	Summary
0.01	Jan 29, 2011	–	First edition issued
1.00	Aug 14, 2012	Throughout	“Preliminary Data Sheet” is changed to “Data Sheet.”
		p.1	Modification of FEATURES
		p.2	Modification of PACKAGE DIMENSIONS
			Modification of PHOTOCOUPLER CONSTRUCTION
			Modification of MARKING EXAMPLE
		p.3	Addition of ORDERING INFORMATION
			Modification of ABSOLUTE MAXIMUM RATINGS
			Modification of RECOMMENDED OPERATING CONDITIONS
		pp.4, 5	Modification of ELECTRICAL CHARACTERISTICS
		pp.6, 7	Addition of TYPICAL CHARACTERISTICS
		p.8	Addition of TAPING SPECIFICATIONS
p.9	Addition of RECOMMENDED MOUNT PAD DIMENSIONS		
pp.10, 11	Addition of NOTES ON HANDLING		
p.12	Addition of SPECIFICATION OF VDE MARKS LICENSE DOCUMENT		

All trademarks and registered trademarks are the property of their respective owners.



## Стандарт Электрон Связь

Мы молодая и активно развивающаяся компания в области поставок электронных компонентов. Мы поставляем электронные компоненты отечественного и импортного производства напрямую от производителей и с крупнейших складов мира.

Благодаря сотрудничеству с мировыми поставщиками мы осуществляем комплексные и плановые поставки широчайшего спектра электронных компонентов.

Собственная эффективная логистика и склад в обеспечивает надежную поставку продукции в точно указанные сроки по всей России.

Мы осуществляем техническую поддержку нашим клиентам и предпродажную проверку качества продукции. На все поставляемые продукты мы предоставляем гарантию .

Осуществляем поставки продукции под контролем ВП МО РФ на предприятия военно-промышленного комплекса России , а также работаем в рамках 275 ФЗ с открытием отдельных счетов в уполномоченном банке. Система менеджмента качества компании соответствует требованиям ГОСТ ISO 9001.

Минимальные сроки поставки, гибкие цены, неограниченный ассортимент и индивидуальный подход к клиентам являются основой для выстраивания долгосрочного и эффективного сотрудничества с предприятиями радиоэлектронной промышленности, предприятиями ВПК и научно-исследовательскими институтами России.

С нами вы становитесь еще успешнее!

### Наши контакты:

**Телефон:** +7 812 627 14 35

**Электронная почта:** [sales@st-electron.ru](mailto:sales@st-electron.ru)

**Адрес:** 198099, Санкт-Петербург,  
Промышленная ул, дом № 19, литера Н,  
помещение 100-Н Офис 331