

Evaluation Board for the **ADM3052** Isolated CAN Transceiver with Integrated High Voltage, Bus Side Linear Regulator

FEATURES

- Easy evaluation of the **ADM3052**
- Isolated, controller area network (CAN) transceiver
- Integrated bus side linear regulator (V₊)
- Bus side powered by V₊ and V₋
- 11 V to 25 V operation on V₊
- 5 V or 3.3 V operation on V_{DD1}
- High speed data rates up to 1 Mbps
- Connect 110 or more nodes on the bus

APPLICATIONS

- CAN data buses
- Industrial field networks
- DeviceNet applications

EVALUATION KIT CONTENTS

EVAL-ADM3052EBZ

GENERAL DESCRIPTION

The EVAL-ADM3052EBZ allows quick and easy evaluation of the **ADM3052** isolated CAN transceiver. The evaluation board allows all the input and output functions of the **ADM3052** to be exercised without the need for external components.

The **ADM3052** is an isolated CAN, physical layer transceiver with a V₊ integrated linear regulator. The **ADM3052** complies with the ISO 11898 standard.

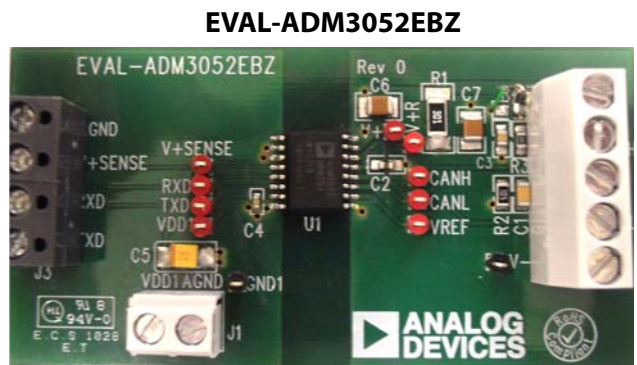

Figure 1.

The device uses Analog Devices, Inc., *iCoupler*® technology to combine a 3-channel isolator, a CAN transceiver, and a linear regulator into a single, 16-lead, wide body SOIC package. The power is isolated between a single 3.3 V or 5 V supply on V_{DD1}, the logic side, and a single 24 V supply provided on V₊, the bus side.

The linear regulator takes the V₊ bus power and regulates it down to 5 V. The linear regulator uses two regulation loops to share the power dissipation between the internal die and an external resistor (R1), which reduces the internal heat dissipation in the package. This 300 Ω external resistor should be capable of dissipating 750 mW of power and have a tolerance of 1%.

Full details on the **ADM3052** are provided in the **ADM3052** data sheet available from Analog Devices, Inc., which should be consulted in conjunction with this evaluation board user guide.

TABLE OF CONTENTS

Features	1	Evaluation Board Configuration	3
Applications.....	1	Setting Up the Evaluation Board.....	3
Evaluation Kit Contents.....	1	Evaluation Board Schematic and Layout	4
EVAL-ADM3052EBZ.....	1	Ordering Information.....	6
General Description	1	Bill of Materials.....	6
Revision History	2	Related Links.....	6

REVISION HISTORY

12/11—Revision 0: Initial Version

EVALUATION BOARD CONFIGURATION

SETTING UP THE EVALUATION BOARD

The EVAL-ADM3052EBZ allows the [ADM3052](#) isolated CAN transceiver to be quickly and easily evaluated. The evaluation board allows all of the input and output functions to be exercised without the need for external components.

On the EVAL-ADM3052EBZ, the power is isolated between a single 3.3 V or 5 V supply on VDD1, the logic side, and a single 24 V supply provided on V+, the bus side.

R1, the 300 Ω external resistor, is used by the built-in linear regulator to share the power dissipation between R1 and the internal die to reduce the internal heat dissipation in the package.

The bus voltage sense pin (V+SENSE), detects when V+ is connected on the bus side. A low on V+SENSE indicates that power is available on the bus side, and a high on V+SENSE indicates that power is absent from the bus side.

VDD1 is the power supply of the logic side. A 22 μF decoupling capacitor, C5, is fitted between VDD1 and GND1. A capacitor of 1 μF is fitted on the C_{INT} pin. A 100 nF capacitor, C6, is fitted between V+ and V−, and a 10 μF capacitor, C7, is fitted between V+R and V−.

An example operation of the EVAL-ADM3052EBZ is shown in Figure 3. Connect a signal generator on TXD and set up a 500 kHz square wave clock with output swing between 0 V and 5 V. Connect the scope probes to the CANH and CANL test points. A plot of the oscilloscope for TXD, CANH, and CANL is shown in Figure 2. Channel 1 shows the TXD signal, and Channel 2 and Channel 3 show the CANH and CANL signals, respectively.

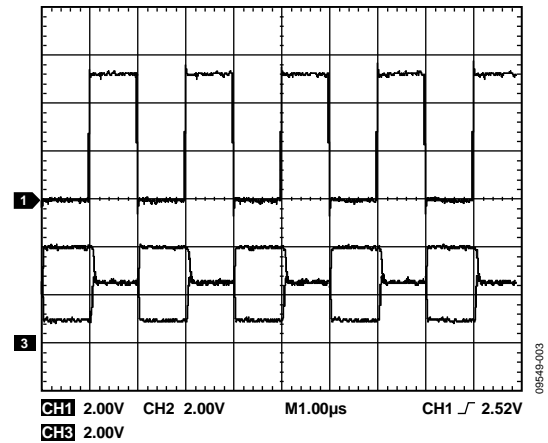

Figure 2. TXD, CANH, and CANL Signals

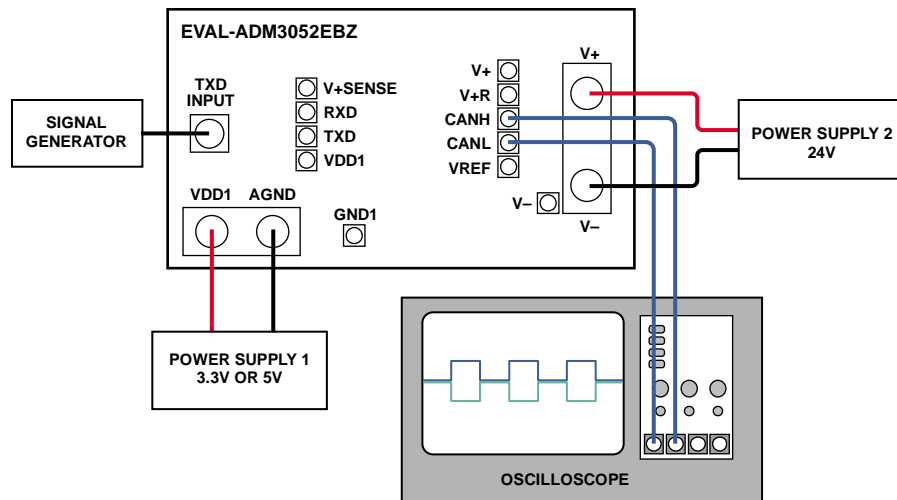

Figure 3. Basic Isolated CAN Transceiver Evaluation Board Operation

EVALUATION BOARD SCHEMATIC AND LAYOUT

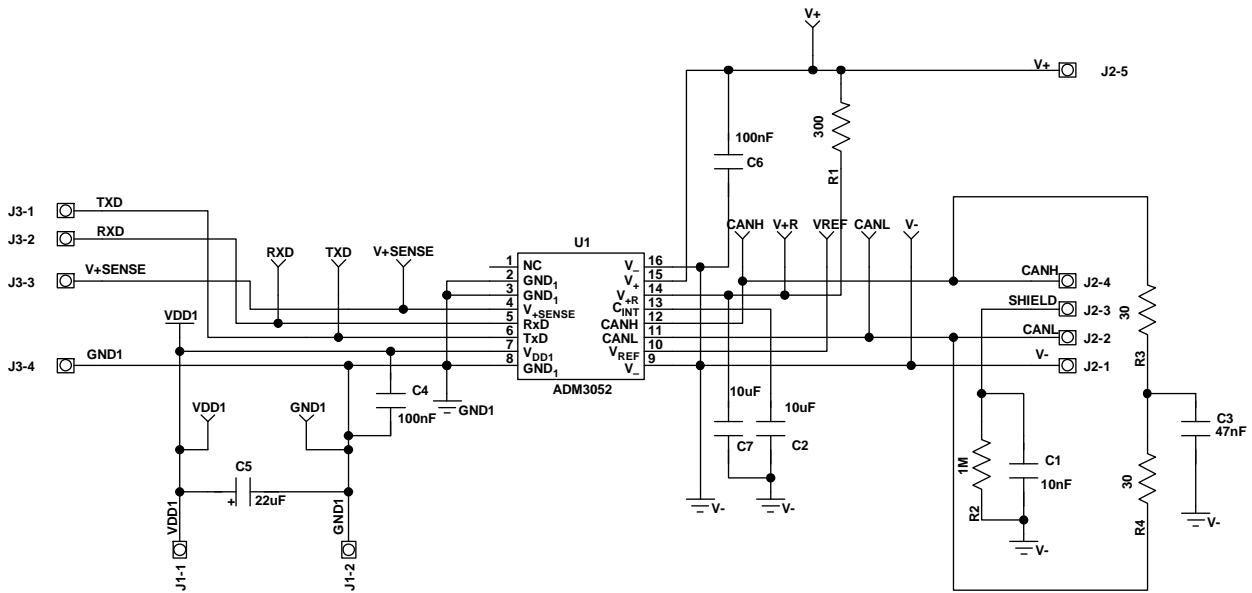

Figure 4. EVAL-ADM3052EBZ Schematic

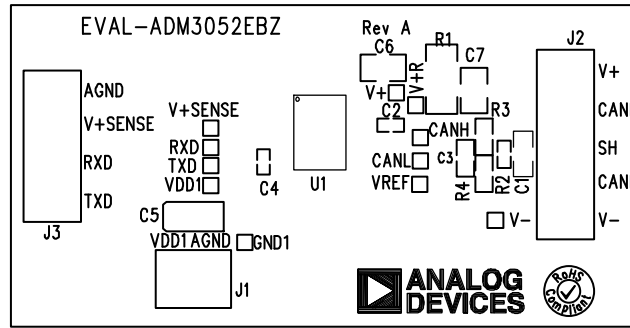

Figure 5. EVAL-ADM3052EBZ Silkscreen

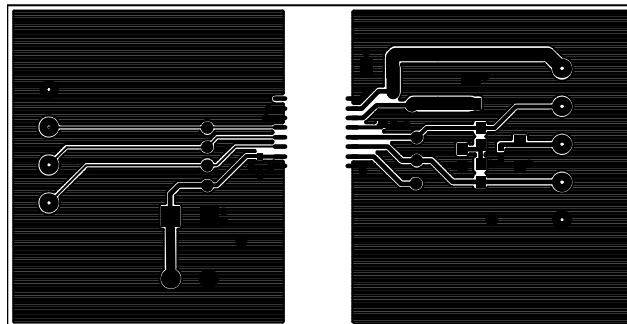

Figure 6. EVAL-ADM3052EBZ Component Side

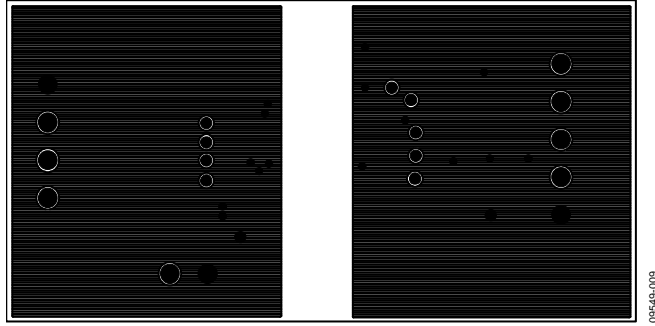

Figure 7. EVAL-ADM3052EBZ Solder Side

ORDERING INFORMATION**BILL OF MATERIALS**

Table 1.

Quantity	Reference Designator	Description	Supplier/Part Number
1	C1	Capacitor, 10 nF, 1206	AVX Corporation/12067C103KAT1A
1	C2	Capacitor, 10 μ F, 0603	KEMET/C0603C106M9PACTU
1	C3	Capacitor, 47 nF, 0805	AVX Corporation/08055C473KAT2A
1	C4	Capacitor, 100 nF, 0603	AVX Corporation/06033C104JAT2A
1	C5	Capacitor, 22 μ F, RTAJ_C	AVX Corporation/TAJB226K016R
1	C6	Capacitor, 100 nF, 1210	KEMET/C1210C104J5GACTU
1	C7	Capacitor, 10 μ F, 1210	Multicomp/MCCA000492
1	CANH	Test point	Vero Technologies/20-313137
1	CANL	Test point	Vero Technologies/20-313137
1	J1	Connector\POWER	Lumberg/KRM 02
1	J2	Connector\POWER5	Lumberg/KRE 05
1	J3	Connector\POWER4	Lumberg/KRM 04
1	R1	Resistor, 300 Ω , 2010	Panasonic/ERJ-12ZYJ301U
1	R2	Resistor, 1 M Ω , 1206	Yageo (Phycomp)/RV1206JR-071ML
2	R3, R4	Resistor, 30 Ω , 0805	Multicomp/MC 0.1W 0805 1% 30R
7	RXD, TXD, V+, V+R, V+SENSE, VDD1, VREF	Test point	Vero Technologies/20-313137
1	U1	16-lead SOIC_W	Analog Devices/ADM3052BRWZ
2	GND1, V-	Test point	Vero Technologies/20-2137

RELATED LINKS

Resource	Description
ADM3052	Product Page, Isolated CAN Transceiver with Integrated High Voltage, Bus-Side, Linear Regulator

NOTES

NOTES

**ESD Caution**

ESD (electrostatic discharge) sensitive device. Charged devices and circuit boards can discharge without detection. Although this product features patented or proprietary protection circuitry, damage may occur on devices subjected to high energy ESD. Therefore, proper ESD precautions should be taken to avoid performance degradation or loss of functionality.

Legal Terms and Conditions

By using the evaluation board discussed herein (together with any tools, components documentation or support materials, the "Evaluation Board"), you are agreeing to be bound by the terms and conditions set forth below ("Agreement") unless you have purchased the Evaluation Board, in which case the Analog Devices Standard Terms and Conditions of Sale shall govern. Do not use the Evaluation Board until you have read and agreed to the Agreement. Your use of the Evaluation Board shall signify your acceptance of the Agreement. This Agreement is made by and between you ("Customer") and Analog Devices, Inc. ("ADI"), with its principal place of business at One Technology Way, Norwood, MA 02062, USA. Subject to the terms and conditions of the Agreement, ADI hereby grants to Customer a free, limited, personal, temporary, non-exclusive, non-sublicensable, non-transferable license to use the Evaluation Board FOR EVALUATION PURPOSES ONLY. Customer understands and agrees that the Evaluation Board is provided for the sole and exclusive purpose referenced above, and agrees not to use the Evaluation Board for any other purpose. Furthermore, the license granted is expressly made subject to the following additional limitations: Customer shall not (i) rent, lease, display, sell, transfer, assign, sublicense, or distribute the Evaluation Board; and (ii) permit any Third Party to access the Evaluation Board. As used herein, the term "Third Party" includes any entity other than ADI, Customer, their employees, affiliates and in-house consultants. The Evaluation Board is NOT sold to Customer; all rights not expressly granted herein, including ownership of the Evaluation Board, are reserved by ADI. CONFIDENTIALITY. This Agreement and the Evaluation Board shall all be considered the confidential and proprietary information of ADI. Customer may not disclose or transfer any portion of the Evaluation Board to any other party for any reason. Upon discontinuation of use of the Evaluation Board or termination of this Agreement, Customer agrees to promptly return the Evaluation Board to ADI. ADDITIONAL RESTRICTIONS. Customer may not disassemble, decompile or reverse engineer chips on the Evaluation Board. Customer shall inform ADI of any occurred damages or any modifications or alterations it makes to the Evaluation Board, including but not limited to soldering or any other activity that affects the material content of the Evaluation Board. Modifications to the Evaluation Board must comply with applicable law, including but not limited to the RoHS Directive. TERMINATION. ADI may terminate this Agreement at any time upon giving written notice to Customer. Customer agrees to return to ADI the Evaluation Board at that time. LIMITATION OF LIABILITY. THE EVALUATION BOARD PROVIDED HEREUNDER IS PROVIDED "AS IS" AND ADI MAKES NO WARRANTIES OR REPRESENTATIONS OF ANY KIND WITH RESPECT TO IT. ADI SPECIFICALLY DISCLAIMS ANY REPRESENTATIONS, ENDORSEMENTS, GUARANTEES, OR WARRANTIES, EXPRESS OR IMPLIED, RELATED TO THE EVALUATION BOARD INCLUDING, BUT NOT LIMITED TO, THE IMPLIED WARRANTY OF MERCHANTABILITY, TITLE, FITNESS FOR A PARTICULAR PURPOSE OR NON-INFRINGEMENT OF INTELLECTUAL PROPERTY RIGHTS. IN NO EVENT WILL ADI AND ITS LICENSORS BE LIABLE FOR ANY INCIDENTAL, SPECIAL, INDIRECT, OR CONSEQUENTIAL DAMAGES RESULTING FROM CUSTOMER'S POSSESSION OR USE OF THE EVALUATION BOARD, INCLUDING BUT NOT LIMITED TO LOST PROFITS, DELAY COSTS, LABOR COSTS OR LOSS OF GOODWILL. ADI'S TOTAL LIABILITY FROM ANY AND ALL CAUSES SHALL BE LIMITED TO THE AMOUNT OF ONE HUNDRED US DOLLARS (\$100.00). EXPORT. Customer agrees that it will not directly or indirectly export the Evaluation Board to another country, and that it will comply with all applicable United States federal laws and regulations relating to exports. GOVERNING LAW. This Agreement shall be governed by and construed in accordance with the substantive laws of the Commonwealth of Massachusetts (excluding conflict of law rules). Any legal action regarding this Agreement will be heard in the state or federal courts having jurisdiction in Suffolk County, Massachusetts, and Customer hereby submits to the personal jurisdiction and venue of such courts. The United Nations Convention on Contracts for the International Sale of Goods shall not apply to this Agreement and is expressly disclaimed.



Стандарт Электрон Связь

Мы молодая и активно развивающаяся компания в области поставок электронных компонентов. Мы поставляем электронные компоненты отечественного и импортного производства напрямую от производителей и с крупнейших складов мира.

Благодаря сотрудничеству с мировыми поставщиками мы осуществляем комплексные и плановые поставки широчайшего спектра электронных компонентов.

Собственная эффективная логистика и склад в обеспечивает надежную поставку продукции в точно указанные сроки по всей России.

Мы осуществляем техническую поддержку нашим клиентам и предпродажную проверку качества продукции. На все поставляемые продукты мы предоставляем гарантию .

Осуществляем поставки продукции под контролем ВП МО РФ на предприятия военно-промышленного комплекса России , а также работаем в рамках 275 ФЗ с открытием отдельных счетов в уполномоченном банке. Система менеджмента качества компании соответствует требованиям ГОСТ ISO 9001.

Минимальные сроки поставки, гибкие цены, неограниченный ассортимент и индивидуальный подход к клиентам являются основой для выстраивания долгосрочного и эффективного сотрудничества с предприятиями радиоэлектронной промышленности, предприятиями ВПК и научно-исследовательскими институтами России.

С нами вы становитесь еще успешнее!

Наши контакты:

Телефон: +7 812 627 14 35

Электронная почта: sales@st-electron.ru

Адрес: 198099, Санкт-Петербург,
Промышленная ул, дом № 19, литера Н,
помещение 100-Н Офис 331