

Circuits from the Lab™
Reference Circuits

Circuits from the Lab™ reference circuits are engineered and tested for quick and easy system integration to help solve today's analog, mixed-signal, and RF design challenges. For more information and/or support, visit www.analog.com/CN0289.

Devices Connected/Referenced

AD8226	Wide Supply Range, Rail-to-Rail Output Instrumentation Amplifier
ADR02	Ultracompact, Precision 5.0V Voltage Reference
ADA4091-2	Precision Micropower, OVP, RRIO Dual Op Amp

Flexible, 4 mA-to-20 mA, Loop-Powered Pressure Sensor Transmitter with Voltage or Current Drive

EVALUATION AND DESIGN SUPPORT

Circuit Evaluation Boards

[CN0289 Evaluation Board \(EVAL-CN0289-EB1Z\)](#)

Design and Integration Files

[Schematics, Layout Files, Bill of Materials](#)

CIRCUIT FUNCTION AND BENEFITS

The circuit shown in Figure 1 is a robust and flexible loop-powered current transmitter that converts the differential voltage output from a pressure sensor to a 4 mA-to-20 mA current output.

The design is optimized for a wide variety of bridge based voltage or current driven pressure sensors, utilizes only four active devices, and has a total unadjusted error of less than 1%. The loop supply voltage can range from 12 V to 36 V.

The input of the circuit is protected for ESD and voltages beyond the supply rail, making it ideal for industrial applications.

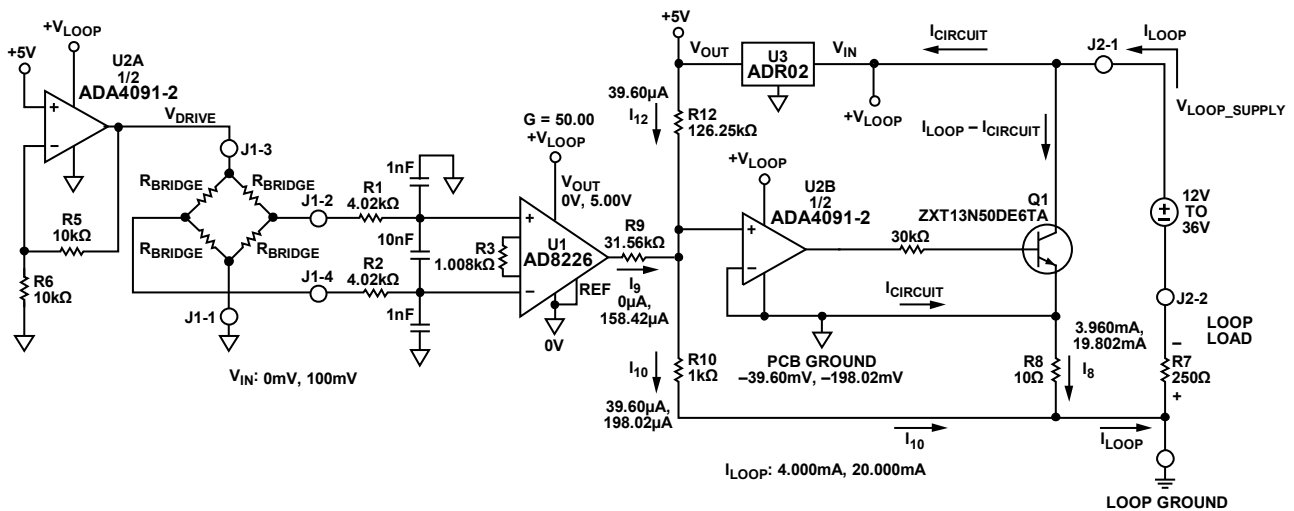

NOTES

- R8, R10 ARE STANDARD 0.1% VALUES. R5, R6 ARE STANDARD 1% VALUES. R3, R9, R12 ARE CALCULATED VALUES (SEE TEXT).
- VOLTAGES MEASURED WITH RESPECT TO PCB GROUND.

Figure 1. Robust Loop Powered Pressure Sensor Signal Conditioning Circuit with 4 mA-to-20 mA Output (Shown in Sensor Voltage Drive Mode)
Simplified Schematic: All Connections and Decoupling Not Shown

Rev. 0

Circuits from the Lab™ circuits from Analog Devices have been designed and built by Analog Devices engineers. Standard engineering practices have been employed in the design and construction of each circuit, and their function and performance have been tested and verified in a lab environment at room temperature. However, you are solely responsible for testing the circuit and determining its suitability and applicability for your use and application. Accordingly, in no event shall Analog Devices be liable for direct, indirect, special, incidental, consequential or punitive damages due to any cause whatsoever connected to the use of any Circuits from the Lab circuits. (Continued on last page)

CIRCUIT DESCRIPTION

The design provides a complete solution for the 4 mA-to-20 mA transmitter for pressure sensor measurements where the supply for the entire circuit is provided by the loop. The circuit has three critical stages: the sensor excitation drive, sensor output amplifier, and the voltage to current converter.

The total current required by the circuit is 1.82 mA (maximum) as shown in Table 1. Pressure sensors requiring bridge drive currents of up to 2 mA can therefore be used without exceeding the maximum available loop current of 4 mA.

Table 1. Maximum Circuit Currents @ 25°C

Component	Current (mA)
ADR02	0.80
ADA4091-2	0.50
AD8226	0.43
R5, R6 @ 10 V	0.05
R12 @ 5 V	0.04
TOTAL	1.82

Sensor Excitation Drive

Depending on the pressure sensor selected, either a voltage or current drive is required. The circuit uses one half of the ADA4091-2 (U2A) with different configurations chosen by switching S1 to support either option. The switch S1 provides the selection for either drive.

Excitation: Voltage Drive Configuration

Figure 2 shows the configuration for the voltage drive with S1 in the position labeled VOLTAGE DRIVE on the PCB (see complete circuit layout and schematics in the CN0289 design support package: <http://www.analog.com/CN0289-DesignSupport>).

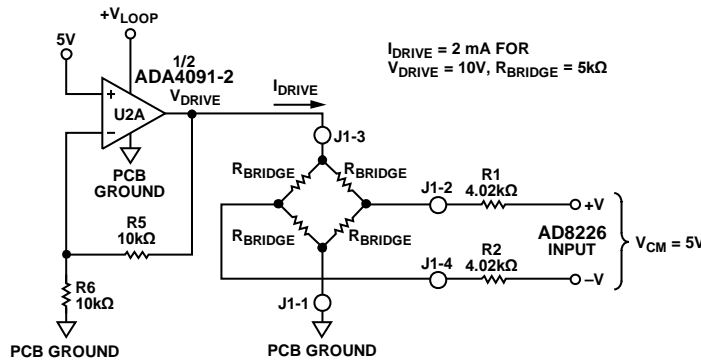

Figure 2. Sensor Voltage Drive Configuration for $R_{BRIDGE} = 5\ \Omega$, $V_{DRIVE} = 10\ V$

10947-002

The voltage drive circuit is normally configured for a bridge drive voltage of 10 V. In this mode, the minimum allowable bridge resistance is:

$$R_{BRIDGE} \geq \frac{2V_{REF}}{2 \text{ mA}} = \frac{10 \text{ V}}{2 \text{ mA}} = 5 \text{ k}\Omega$$

For lower than 5 kΩ bridge resistance, the drive voltage can be decreased down to 5 V using a buffer configuration by removing R6.

Other values of drive voltage can be obtained by properly selecting R6 using the equation:

$$V_{DRIVE} = 5 \text{ V} \left(1 + \frac{R5}{R6} \right)$$

$$R6 = \frac{5 \text{ V} \times R5}{V_{DRIVE} - 5 \text{ V}}$$

where

$$\frac{V_{DRIVE}}{R_{BRIDGE}} \geq 2 \text{ mA}$$

Note that the loop voltage, V_{LOOP} , should be at least 0.2 V greater than the bridge drive voltage to allow sufficient headroom for U2A.

$$V_{LOOP} \geq V_{DRIVE} + 0.2 \text{ V}$$

Excitation: Current Drive Configuration

The circuit can be switched to the current drive configuration shown in Figure 3 by moving S1 to the position labeled CURRENT DRIVE on the PCB.

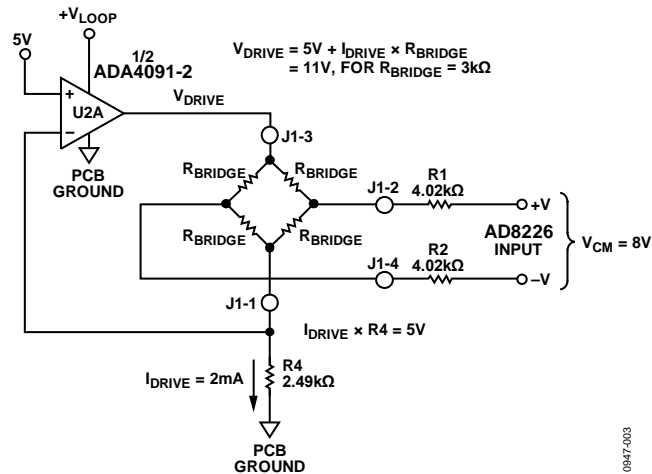

Figure 3. Sensor Current Drive Configuration for $R_{BRIDGE} = 3 \text{ k}\Omega$

10947-003

In the current drive mode, the 2 mA maximum allowable bridge drive current must be observed. The circuit is configured for $R4 = 2.49 \text{ k}\Omega$, and $I_{\text{DRIVE}} = 2 \text{ mA}$. Lower values of I_{DRIVE} can be obtained by using the following equation to select the value of R4:

$$R4 = \frac{5 \text{ V}}{I_{\text{DRIVE}}}$$

The resulting drive voltage V_{DRIVE} is calculated from:

$$V_{\text{DRIVE}} = 5 \text{ V} + I_{\text{DRIVE}} \times R_{\text{BRIDGE}}$$

A headroom of 0.2 V is required for the U2A supply, therefore:

$$V_{\text{LOOP}} \geq V_{\text{DRIVE}} + 0.2 \text{ V}$$

For the values shown in Figure 3, $R_{\text{BRIDGE}} = 3 \text{ k}\Omega$, $I_{\text{DRIVE}} = 2 \text{ mA}$, $V_{\text{DRIVE}} = 11 \text{ V}$, and $V_{\text{LOOP}} \geq 11.2 \text{ V}$.

The [ADA4091-2](#) op amp is chosen for the circuit because of its low current consumption (250 μA /amplifier), low offset voltage (250 μV), and rail-to-rail inputs and outputs.

Bridge Output Instrumentation Amplifier and Selection of Gain and Offset Resistors

The output of the bridge is filtered by a common-mode filter (4.02 k Ω , 1 nF) with a bandwidth of 39.6 kHz and a differential-mode filter (8.04 k Ω , 10 nF) with a bandwidth of 2 kHz.

The [AD8226](#) is an ideal choice for the in-amp because of its low gain error (0.1%, B-grade), low offset (58 μV @ $G = 50$, B-grade; 112 μV @ $G = 50$, A-grade), excellent gain nonlinearity (75 ppm = 0.0075%), and rail-to-rail output.

The [AD8226](#) instrumentation amplifier amplifies the 100 mV FS signal by a factor of 50 V to 5 V using a gain setting resistor $R3 = 1.008 \text{ k}\Omega$. The relationship between the gain, G, and R3 is given by

$$R3 = \frac{49.4 \text{ k}\Omega}{G - 1}$$

where $G = 50$, and $R3 = 1008 \Omega$.

For the output zero-value loop current, $I_{\text{LO}} = 4 \text{ mA}$:

$$I_{\text{LO}} = I_8 + I_{10}$$

Because of the 100:1 ratio of R10 to R8:

$$I_8 = 100 \times I_{10}$$

Combining the last two equations:

$$I_{\text{LO}} = 101 \times I_{10}$$

The [AD8226](#) output is 0 V for $I_{\text{LO}} = 4 \text{ mA}$, and the offset resistor R12 can now be calculated from:

$$R12 = \frac{V_{\text{REF}}}{I_{10}} = \frac{101 \times V_{\text{REF}}}{I_{\text{LO}}} = \frac{101 \times 5 \text{ V}}{4 \text{ mA}} = 126.25 \text{ k}\Omega$$

For $V_{\text{OUT}} = 5.00 \text{ V}$, the output loop current is $I_{\text{LH}} = 20 \text{ mA}$, and hence:

$$I_{\text{LH}} = I_8 + I_{10} = 100 \times I_{10} + I_{10} = 101 \times I_{10}$$

$$I_{10} = \frac{I_{\text{LH}}}{101} = \frac{20 \text{ mA}}{101} = 198.02 \mu\text{A}$$

The current through R12 is given by:

$$I_{12} = \frac{V_{\text{REF}}}{R12} = \frac{5 \text{ V}}{126.25 \text{ k}\Omega} = 39.60 \mu\text{A}$$

The current through R9 is given by:

$$I_9 = I_{10} - I_{12} = 198.02 \mu\text{A} - 39.60 \mu\text{A} = 158.42 \mu\text{A}$$

The value of R9 can now be calculated from:

$$R9 = \frac{V_{\text{OUT}}}{I_9} = \frac{5 \text{ V}}{158.42 \mu\text{A}} = 31.56 \text{ k}\Omega$$

In practice, the calculated values for R3, R12, and R9 will not be available as standard values, so there will be fixed errors introduced by the actual values used in the circuit. These errors can be calculated as follows.

Gain, offset, and total error, measured as a %FSR (where FSR = 16 mA) due to resistors R3, R9, and R12:

Gain Error (%FSR) =

$$\left[\left(\frac{1008 \Omega - R3}{1008 \Omega} \right) + \left(\frac{31.56 \text{ k}\Omega - R9}{31.56 \text{ k}\Omega} \right) \right] \times 100\%$$

Offset Error (%FSR) =

$$0.25 \left(\frac{126.25 \text{ k}\Omega - R12}{126.25 \text{ k}\Omega} \right) \times 100\%$$

The total error at zero output (4 mA) is not affected by the gain error.

However, the total error at full-scale output (20 mA) is equal to:

$$\text{Full Scale Error} = \text{Gain Error} + \text{Offset Error}$$

In the practical circuit, the nearest EIA standard 0.1% resistor values must be chosen, thereby resulting in fixed gain and offset errors as described in the previous equations. It is possible to use combinations of two 0.1% values to come closer to the calculated values. For instance, the following series combinations of 0.1% resistors come very close to the calculated values:

- $R3 = 1 \text{ k}\Omega + 8.06 \Omega = 1008.06 \Omega$ (calculated = 1008 Ω)
- $R9 = 30.9 \text{ k}\Omega + 655 \Omega = 31.555 \text{ k}\Omega$ (calculated = 31.56 k Ω)
- $R12 = 124 \text{ k}\Omega + 2.26 \text{ k}\Omega = 126.26 \Omega$ (calculated = 126.25 Ω).

The error calculated with these combinations is as follows:

- Offset Error = -0.008% FSR
- Gain Error = +0.010% FSR
- Full Scale Error = +0.002% FSR

In some cases, however, even standard 0.1% resistor values may not be obtainable from resistor suppliers, and substitutions are required.

For example, the resistors supplied with the [EVAL-CN0289-EB1Z](#) board are as follows:

- R3 = 1000 Ω (calculated = 1008 Ω)
- R9 = 31.6 k Ω (calculated = 31.56 k Ω)
- R12 = 124 k Ω (calculated = 126.25 k Ω)

With the values supplied with the board, the errors due to the resistor values are:

- Offset Error = +0.45% FSR
- Gain Error = +0.66% FSR
- Full Scale Error = +1.11% FSR

Voltage Reference

The [ADR02](#) 5 V reference is used to set the drive voltage or current to the bridge and to set the 4 mA zero offset. It has an initial accuracy of 0.1% (A-grade), 0.06% (B-grade), and 10 μ V p-p voltage noise. In addition it will operate on supply voltages up to 36 V and consumes less 1 mA maximum, making it an ideal choice for loop-powered applications.

Voltage-to-Current Conversion

The 4 mA-to-20 mA output is produced by forcing a current through R10 that is the sum of the signal component (I_9) and the offset component (I_{12}). The current $I_{10} = I_9 + I_{12}$ develops a voltage across R10 that is applied to the sense resistor R10 through U2B and Q1. The current through R8 is 100 \times the current in R10. The loop current, I_{LOOP} , is therefore :

$$I_{LOOP} = I_8 + I_{10} = 100 \times I_{10} + I_{10} = 101 \times I_{10}$$

The values of R8 (10 Ω) and R10 (1 k Ω) were chosen to be values that are easily obtainable in 0.1% tolerances.

In order for the circuit to operate properly, the circuit current, $I_{CIRCUIT}$, must always be less than the minimum loop current of 4 mA. In addition, the ground of the PCB must not be connected to the loop ground in any manner, and the PCB ground and the sensor must be free to float with respect to the loop ground.

The bipolar NPN transistor that is controlled by the output of U2B and generates the loop current should have a gain of at least 300 to minimize the linearity error. It should also have a breakdown voltage of at least 50 V.

The output transistor Q1 is a 50 V NPN power transistor capable of dissipating 1.1 W @ 25 $^{\circ}$ C. The worst case power dissipation in the circuit is for an output current of 20 mA into a loop load resistance of 0 Ω with a V_{CC} supply of 36 V. Under these conditions the power dissipation of Q1 is 0.68 W.

The supply voltage, V_{LOOP} , driving the circuit board is dependent on the loop supply V_{LOOP_SUPPLY} , the loop load, R7, and the loop current, I_{LOOP} . These values are related by the following equation:

$$V_{LOOP} = V_{LOOP_SUPPLY} - R7 \times I_{LOOP}$$

In order for the circuit to operate properly, the supply voltage, V_{LOOP} , must be greater than 7 V in order to provide sufficient headroom for the [ADR02](#) voltage reference.

Therefore,

$$V_{LOOP_SUPPLY} > 7 \text{ V} + R7 \times I_{LOOP}$$

For a maximum loop current of 20 mA, and R7 = 250 Ω ,

$$V_{LOOP_SUPPLY} > 7 \text{ V} + 250 \Omega \times 20 \text{ mA} = 12 \text{ V}$$

The minimum loop supply voltage is also dependent on the configuration of the drive circuit for the bridge. In the voltage drive mode with $V_{DRIVE} = 10 \text{ V}$, the supply voltage V_{LOOP} must be greater than 10.2 V in order to maintain sufficient headroom for U2A (see Figure 2).

In the current drive mode, the supply voltage V_{LOOP} must be greater than 11.2 V in order to maintain sufficient headroom for U2A (see Figure 3).

The loop supply voltage is limited to 36 V maximum.

Error Analysis for Active Components

The maximum and rss errors due to the active components in the system for A- and B-grade levels of the [AD8226](#) and [ADR02](#) are shown in Table 2 and Table 3. Note that the [ADA4091-2](#) op amp is only available in one grade level.

Table 2. Errors Due to Active Components (A-Grade)

Error Component	Error	Error Value	Error %FSR
AD8226-A	Offset	112 μ V	0.11%
ADR02-A	Offset	0.10%	0.02%
ADA4091-2	Offset	250 μ V	0.16%
AD8226-A	Gain	0.15%	0.15%
RSS Offset			0.20%
RSS Gain			0.15%
RSS FS Error			0.35%
Max Offset			0.29%
Max Gain			0.15%
Max FS Error			0.44%

Table 3. Errors Due to Active Components (B-Grade)

Error Component	Error	Error Value	Error %FSR
AD8226-B	Offset	58 μ V	0.06%
ADR02-B	Offset	0.06%	0.01%
ADA4091-2	Offset	250 μ V	0.16%
AD8226-B	Gain	0.10%	0.10%
RSS Gain			0.10%
RSS Offset			0.17%
RSS FS Error			0.27%
Max Offset			0.23%
Max Gain			0.10%
Max FS Error			0.33%

Total Circuit Accuracy

A good approximation to the total error contributed by the resistor tolerances is to assume that each of the critical resistors contribute equally to the total error. The five critical resistors are R3, R8, R9, R10, and R12. Worst-case tolerance build up of 0.1% resistors yields a total resistor error of 0.5% maximum. If rss errors are assumed, then the total rss error is $0.1\sqrt{5} = 0.224\%$.

Adding the worst case resistor tolerance error of 0.5% to the previous worst-case errors due to the active components (A-grade) yields:

- Offset Error = $0.29\% + 0.5\% = 0.79\%$
- Gain Error = $0.15\% + 0.5\% = 0.65\%$
- Full Scale Error = $0.44\% + 0.5\% = 0.94\%$

These errors assume ideal resistors are selected and that the only errors are due to their tolerances.

Although the circuit is capable of 1% or less total error, if better accuracy is required offset and gain adjustment capability should be added to the circuit. Offset can be calibrated by adjusting R12 for 4 mA output with zero input, and full-scale can then be adjusted by varying R9 for a full-scale 100 mV input. The two adjustments are independent provided the offset is calibrated first.

Actual error data from the circuit is shown in Figure 4. The total output error (%FSR) is calculated by taking the difference between the ideal output current and the measured output current, dividing by the FSR (16 mA), and multiplying the result by 100.

Note that the error between 0 mV and 1 mV input is due to the saturation voltage of the AD8226 output stage that can range from 20 mV to 100 mV under the loading conditions in the circuit. All rail-to-rail output stages are limited in their ability to approach the supply rails by either the saturation voltage (bipolar outputs) or on-resistance (CMOS outputs).

If the error caused by the output saturation voltage is troublesome, the input signal from the bridge can be offset by connecting an appropriate resistor from the +5 V reference to one side of the bridge output.

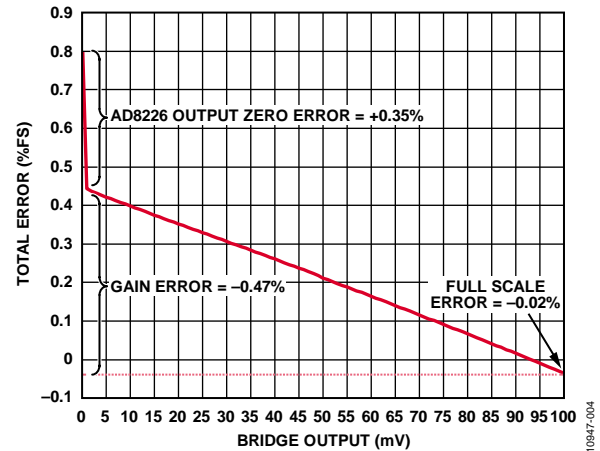

Figure 4. Total Error in Output Current (%FSR) vs. Bridge Output for 3 k Ω Bridge, 24 V Loop Supply

COMMON VARIATIONS

The circuit is proven to work with good stability and accuracy with component values shown. Other voltage references, precision op-amps and in-amp can be used in this configuration to develop 4 mA-to-20 mA analog current output and for other various applications for this circuit.

The ADA4091-4 is a quad version and can be used as a substitute for the ADA4091-2, dual channel, if additional precision op amps are needed.

The AD8426, a dual-channel, low cost, and wide supply range instrumentation amplifier can also be used for multiple input channel applications.

The ADR4550, high precision, low power, low noise voltage references can be used to replace ADR02 for a low voltage supply applications.

CIRCUIT EVALUATION AND TEST

Equipment Required

- EVAL-CN0289-EB1Z evaluation board
- Agilent E36311A dual dc power supply or equivalent
- Agilent 3458A multimeter or equivalent

Current Output Measurement

The current output of the evaluation board was measured with a setup seen in Figure 5. The test conditions were as follows:

- Loop supply: 24 V
- Loop load: 250 Ω
- $R_{\text{BRIDGE}} = 3 \text{ k}\Omega$
- $V_{\text{DRIVE}} = 5 \text{ V}$
- $V_{\text{CM}} = 2.5 \text{ V}$

The bridge resistors are connected to both terminal inputs of the in-amp to simulate sensor output.

Test Setup Configuration and Tests

The circuit was tested using the test setup in Figure 5.

The Agilent E36311A dual power supply was used to generate a common-mode voltage of 2.5 V and a 0 mV to 100 mV differential input voltage.

The Agilent 3458A was used to measure the actual loop current output of the evaluation board.

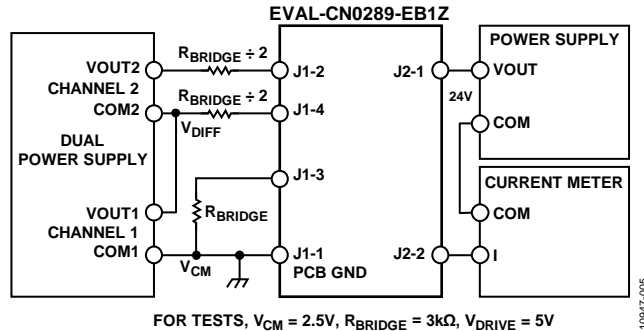

Figure 5. Functional Block Diagram of Test Setup

LEARN MORE

CN-0289 Design Support Package:

<http://www.analog.com/CN0289-DesignSupport>.

MT-031 Tutorial, *Grounding Data Converters and Solving the Mystery of AGND and DGND*. Analog Devices.

MT-035 Tutorial, *Op Amp Inputs, Outputs, Single-Supply, and Rail-to-Rail Issues*. Analog Devices.

MT-065 Tutorial, *In-Amp Noise*. Analog Devices.

MT-066 Tutorial, *In-Amp Bridge Circuit Error Budget Analysis*. Analog Devices.

MT-087 Tutorial, *Voltage References*. Analog Devices.

MT-101 Tutorial, *Decoupling Techniques*. Analog Devices.

Voltage Reference Wizard Design Tool.

Data Sheets and Evaluation Boards

CN-0289 Circuit Evaluation Board (EVAL-CN0289-EB1Z)

AD8226 Data Sheet

ADA4091-2 Data Sheet

ADR02 Data Sheet

REVISION HISTORY

5/13—Revision 0: Initial Version

(Continued from first page) Circuits from the Lab circuits are intended only for use with Analog Devices products and are the intellectual property of Analog Devices or its licensors. While you may use the Circuits from the Lab circuits in the design of your product, no other license is granted by implication or otherwise under any patents or other intellectual property by application or use of the Circuits from the Lab circuits. Information furnished by Analog Devices is believed to be accurate and reliable. However, Circuits from the Lab circuits are supplied "as is" and without warranties of any kind, express, implied, or statutory including, but not limited to, any implied warranty of merchantability, noninfringement or fitness for a particular purpose and no responsibility is assumed by Analog Devices for their use, nor for any infringements of patents or other rights of third parties that may result from their use. Analog Devices reserves the right to change any Circuits from the Lab circuits at any time without notice but is under no obligation to do so.

©2013 Analog Devices, Inc. All rights reserved. Trademarks and registered trademarks are the property of their respective owners.
CN10947-0-5/13(0)





Стандарт Электрон Связь

Мы молодая и активно развивающаяся компания в области поставок электронных компонентов. Мы поставляем электронные компоненты отечественного и импортного производства напрямую от производителей и с крупнейших складов мира.

Благодаря сотрудничеству с мировыми поставщиками мы осуществляем комплексные и плановые поставки широчайшего спектра электронных компонентов.

Собственная эффективная логистика и склад в обеспечивает надежную поставку продукции в точно указанные сроки по всей России.

Мы осуществляем техническую поддержку нашим клиентам и предпродажную проверку качества продукции. На все поставляемые продукты мы предоставляем гарантию .

Осуществляем поставки продукции под контролем ВП МО РФ на предприятия военно-промышленного комплекса России , а также работаем в рамках 275 ФЗ с открытием отдельных счетов в уполномоченном банке. Система менеджмента качества компании соответствует требованиям ГОСТ ISO 9001.

Минимальные сроки поставки, гибкие цены, неограниченный ассортимент и индивидуальный подход к клиентам являются основой для выстраивания долгосрочного и эффективного сотрудничества с предприятиями радиоэлектронной промышленности, предприятиями ВПК и научно-исследовательскими институтами России.

С нами вы становитесь еще успешнее!

Наши контакты:

Телефон: +7 812 627 14 35

Электронная почта: sales@st-electron.ru

Адрес: 198099, Санкт-Петербург,
Промышленная ул, дом № 19, литера Н,
помещение 100-Н Офис 331