



PRELIMINARY
CUSTOMER PROCUREMENT SPECIFICATION

(MARCOM) DC4243 DOCUMENT CONTROL
MASTER

Z86228
LINE 21 CLOSED CAPTION
CONTROLLER (L21C)

GENERAL DESCRIPTION

The Z86228 (Line 21 Closed-Caption Controller) is a single I.C. designed to provide the functional performance of a L21C Decoder module. This Superintegration™ VLSI device is completely self contained requiring only composite video, a horizontal timing signal as input and an external keyer (i.e., video switch between TV video and Closed-Caption video) to produce captioned video. The Z86228 uses a wired logic approach to perform the functions selected through its input control signals. It is fabricated using standard CMOS technology and designed to achieve the lowest possible cost.

The Z86228 is intended for use in a set-top decoder or in any television receiver conforming to the NTSC standard. It is capable of processing and displaying all standard L21C format transmissions including the codes specified

by the FCC "Report and Order" on GEN Docket No. 91-1, dated April 12, 1991. In addition, the device conforms to the Electronic Industry Association's Recommended Practice 608, which provides supplemental guidelines for the transmission of captions, text, and Extended Data Services (EDS) on NTSC Field 2. Extended Data Services (EDS) packets encoded on Field 2, may be displayed in either of two screen formats. If and when PAL and SECAM TV standards define a protocol using the Line 21 format, this design will be readily convertible to that standard.

The Line 21 Closed Captioning System

The L21C system provides for the transmission of CAPTION information and other TEXT material as an encoded composite data signal. This is during the unblanked portion of Line 21, field 1, of the standard NTSC video signal. The video signal conforms to the Standard Synchronizing Waveform for Color Transmission given in Sub-part E, Part 73 of the FCC Rules and Regulations.

PIN DESCRIPTION

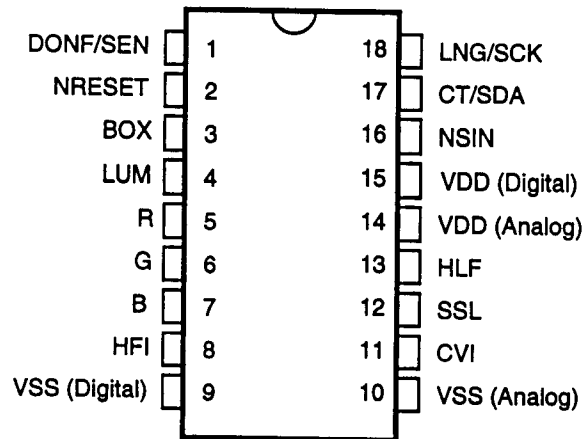

18-Pin DIP Package Diagram

Pin No.	Signal Description
11	Composite Video Input (CVI) Composite NTSC video, nominally 1.0V p-p., band limited to 600 kHz. Circuit operates with signal variations between 0.7-1.4V p-p. It is recommended that this signal pin be driven by an emitter follower through a 0.1 μ F capacitor.
12	Sync Slice Level (SSL) Capacitor (0.1 μ F) to store sync slice level voltage.
8	H Flyback Input (HFI) Horizontal sync input at CMOS levels, polarity independent. Typically derived from the H Flyback pulse or any other horizontal timing signal.
13	H Loop Filter (HLF) Value to be specified
9	V_{ss} (Digital) Digital Ground Connect to system ground
1	DONF/SEN Input (control) In Parallel Mode this input controls the Decoder On/Off function CMOS input with High = On, Low = Off. In Serial Mode this input is the Enable for serial data input.
17	CT/SDA Input (control) In Parallel Mode this input selects the Data Channel to be processed (along with LNG). CMOS input with High=CAPTIONS, Low=TEXT. In Serial mode this input is serial data input.

Pin No.	Signal Description
2	NRESET Master reset for the I.C. and must be used in the Parallel Control Mode. It may be tied High in the Serial Mode if reset is to be performed through the serial data stream.
18	LAG/SCK Input (control) In Parallel Mode this input selects the Data Channel to be processed (along with CT). CMOS input High=LANGUAGE I, Low=LANGUAGE II. In Serial Mode this input is Serial Clock In.
3	Box Output (Box) Active High, CMOS level "black box" keying signal for Caption/Text display area.
4	Luminance Output (LUM) Active High, CMOS level signal. Character video luminance signal.
5, 6, 7	Color signals, RGB Outputs Active High, CMOS level color character video for color receiver use.
15	V_{DD} Digital Power pin. Connect to +5V source.
14	V_{DD} Analog
10	V_{ss} Analog. Analog Ground. Connect to system ground.
16	(NSIN) Input (Control) Selects the mode to be used in interpreting the signals on the three Control pins. High = Parallel Mode, Low = Serial Mode.

Horizontal Timing

The timing of the output signals; Box, Luminance, and RGB is set so that the start of the leading box preceding the first displayable character cell will occur at $13.6 \mu\text{s}$. (*Value may be altered by a Mask change - consult factory.) This is after the midpoint of the leading edge of the horizontal sync pulse of the composite video signal measured at pin 11 of the Z86228. It is assumed that the delay through the low pass filter will be 220 ns (reference Figure).

There are two ways to execute a FULL RESET of the Z86228:

1. Hold NRESET Low for 100 ns. This stops all internal circuits. The part is static and the 100 ns is the worst

case time for the NRESET signal to propagate through the various gates.

2. Send NRESET command through the serial interface. The result is the same as in number 1.

FULL RESET is useful during power-up. A FULL RESET of the part during normal operation is not necessary.

A partial reset may also be executed through the serial interface only. This is the COMMAND PROCESSOR RESET. Basically, all internal timing circuits continue to operate, but the caption display is removed from the screen and the Z86228 waits for new line 21 data. This is useful for situations such as channel change.

DC CHARACTERISTICS

$T_A = 0^\circ\text{C}$ to $+70^\circ\text{C}$; $V_{CC} = +4.75\text{V}$ to $+5.25\text{V}$

Sym	Parameter	Min	Max	Units	Conditions
V_{IL}	Input Voltage Low	0	$0.2V_{CC}$	V	
V_{IH}	Input Voltage High	$0.7V_{CC}$	V_{CC}	V	
V_{OL}	Output Voltage Low		0.4	V	$I_{OL} = 1.00 \text{ mA}$
			1	V	$I_{OL} = 50 \mu\text{A}$ [1]
V_{OH}	Output Voltage High	$V_{CC} - 0.4$		V	$I_{OH} = 0.75 \text{ mA}$ [2]
I_{IL}	Input Leakage	-0	3.0	μA	$0\text{V}, V_{CC}$
I_{CC}	Supply Current		25	mA	[3]

Notes:

- [1] Pin 13 (HLF)
- [2] Pin 17 (CT/SDA) is Open-Drain.
- [3] V_{DD} Digital + V_{DD} Analog combined.

ABSOLUTE MAXIMUM RATINGS

Sym	Description	Min	Max	Units
V_{CC}	Supply Voltage*	-0.3	+7.0	V
T_{STG}	Storage Temp	-65°C	$+150^\circ\text{C}$	C
T_A	Oper Ambient Temp	0°	70°	C

Notes:

- * Voltages on all pins with respect to GND.

STANDARD TEST CONDITIONS

The characteristics listed below apply for standard test conditions as noted. All voltages are referenced to GND. Positive current flows into the referenced pin in Standard Test Load.

Stress greater than those listed under Absolute Maximum Ratings may cause permanent damage to the device. This is a stress rating only; operation of the device at any condition above those indicated in the operational sections of these specifications is not implied. Exposure to absolute maximum rating conditions for an extended period may affect device reliability.

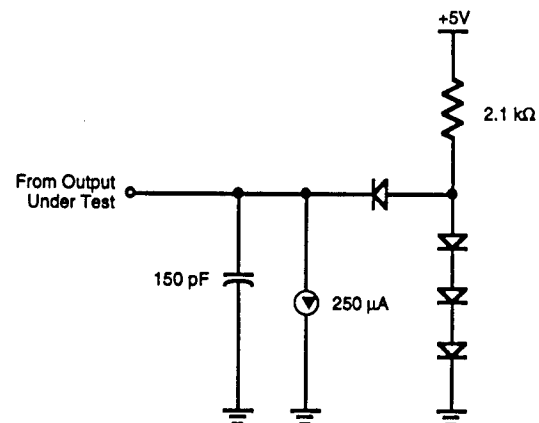

Standard Test Load

AC AND TIMING CHARACTERISTICS*

(Reference Line 21 AC/DC Timing)

Composite Video Input

Amplitude: 1.0 V p-p, ± 3 dB
Polarity: Sync tips negative
Bandwidth: 600 kHz

Horizontal Signal Input (preferably H Flyback)

Amplitude: CMOS level signal, Low $\leq 0.2V_{CC}$, High $\geq 0.7V_{CC}$
Polarity: Any
Frequency: 15,734.263 Hz, $\pm 3\%$

Line 21¹ Input Parameters (at 1.0 V p-p)

Code Level: 50 IRE ± 10 IRE
Clock Run-in Start ²: 10.5 μ s, $\pm 0.5\mu$ s

Input Signal-to-Random Noise Performance

Unit will function down to a 25 dB ratio (CCIR weighted) with one error per row or better at that level.

Internal Sync Circuits

The internal sync circuits will lock to all 525 line signals having a vertical sync pulse that meets the following conditions:

- It is at least 2.5H long.
- It starts at the proper 2H boundary for its field.
- If equalizing pulse serrations are present they must be less than 0.125H in width.

Timing Signals

Dot Clock: 768 x FH = 12.0839 MHz
Dot Period: 82.75 nsec
Character Cell Width: 1.324 μ sec
Width of Row (Box): 45.018 μ sec
Width of Row (Char): 42.370 μ sec

*All values are nominal and not fully characterized.

AC/DC TIMING

Line 21

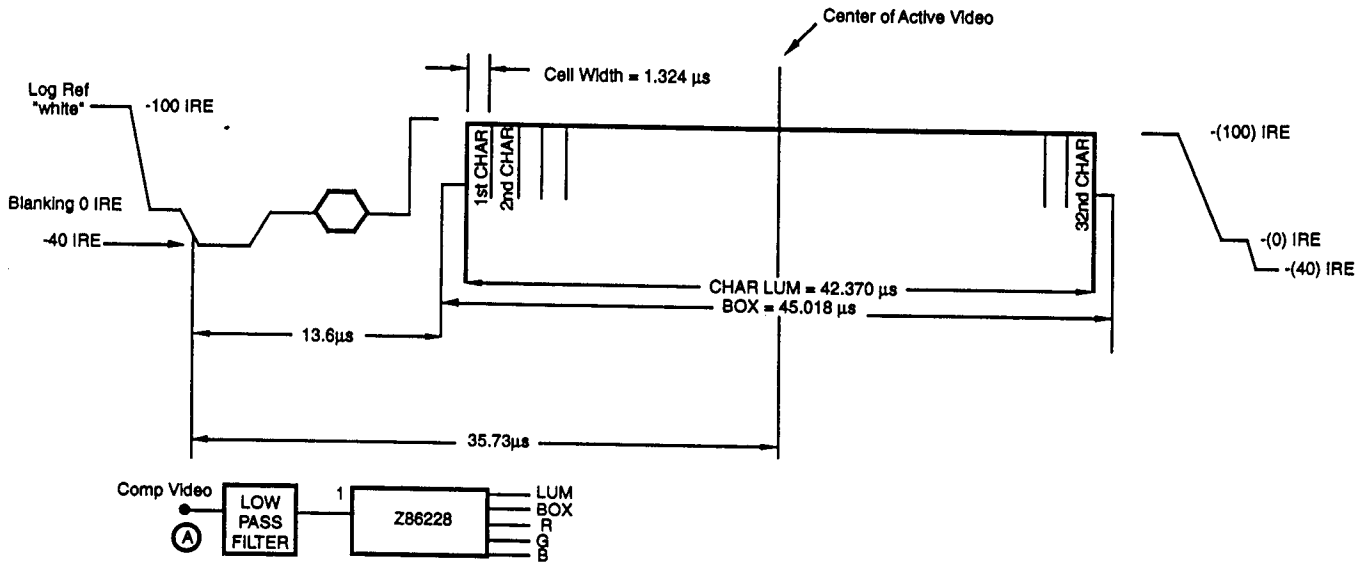

Line 21 AC/DC Timing

AC CHARACTERISTICS

$T_A = 0^\circ\text{C to } +70^\circ\text{C}; V_{CC} = +4.75\text{V to } +5.25\text{V}$

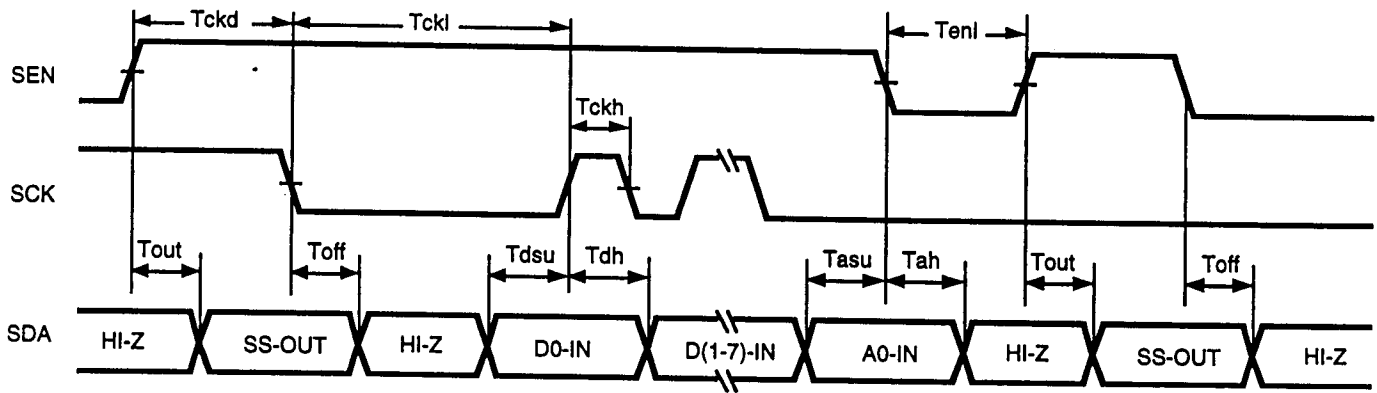

Serial Mode Timing Diagram

Symbol	Description	Min.	Max.	Units
T_{OUT}	Output enable time, ENA rising edge to Data Out		200	ns
T_{OFF}	Output disable time, CLK or ENA falling edge to Data Hi-Z		100	ns
T_{CKD}	Data read time, ENA rising edge to CLK low	200		ns
T_{CKL}	CLK low time	200		ns
T_{CKH}	CLK high time	200		ns
T_{DSU}	Data set-up time	100		ns
T_{DH}	Data hold time	100		ms
T_{ENL}	ENA low time	200		ns
T_{ASU}	A0 set-up time	100		ns
T_{AH}	A0 hold time	100		ns

Low Margin:

Customer is advised that this product does not meet Zilog's internal guardbanded test policies for the specification requested and is supplied on an exception basis. Customer is cautioned that delivery may be uncertain and that, in addition to all other limitations on Zilog liability

stated on the front and back of the sales order acknowledgement, Zilog makes no claim as to quality and reliability under the CPS. The product remains subject to standard warranty for replacement due to defects in materials and workmanship.

Pre-Characterization Product:

The product represented by this CPS is newly introduced and Zilog has not completed the full characterization of the product. The CPS states what Zilog knows about this product at this time, but additional features or non-

conformance with some aspects of the CPS may be found, either by Zilog or its customers in the course of further application and characterization work. In addition, Zilog cautions that delivery may be uncertain at times, due to start-up yield issues.

© 1994 by Zilog, Inc. All rights reserved. No part of this document may be copied or reproduced in any form or by any means without the prior written consent of Zilog, Inc. The information in this document is subject to change without notice. Devices sold by Zilog, Inc. are covered by warranty and patent indemnification provisions appearing in Zilog, Inc. Terms and Conditions of Sale only. Zilog, Inc. makes no warranty, express, statutory, implied or by description, regarding the information set forth herein or regarding the freedom of the described devices from intellectual property infringement. Zilog, Inc. makes no warranty of merchantability or fitness for any purpose. Zilog, Inc. shall not be responsible for any errors that may appear in this document. Zilog, Inc. makes no commitment to update or keep current the information contained in this document.

Zilog's products are not authorized for use as critical components in life support devices or systems unless a specific written agreement pertaining to such intended use is executed between the customer and Zilog prior to use. Life support devices or systems are those which are intended for surgical implantation into the body, or which sustains life whose failure to perform, when properly used in accordance with instructions for use provided in the labeling, can be reasonably expected to result in significant injury to the user.

Zilog, Inc. 210 East Hacienda Ave.
Campbell, CA 95008-6600
Telephone (408) 370-8000
Telex 910-338-7621
FAX 408 370-8056



Стандарт Электрон Связь

Мы молодая и активно развивающаяся компания в области поставок электронных компонентов. Мы поставляем электронные компоненты отечественного и импортного производства напрямую от производителей и с крупнейших складов мира.

Благодаря сотрудничеству с мировыми поставщиками мы осуществляем комплексные и плановые поставки широчайшего спектра электронных компонентов.

Собственная эффективная логистика и склад в обеспечивает надежную поставку продукции в точно указанные сроки по всей России.

Мы осуществляем техническую поддержку нашим клиентам и предпродажную проверку качества продукции. На все поставляемые продукты мы предоставляем гарантию .

Осуществляем поставки продукции под контролем ВП МО РФ на предприятия военно-промышленного комплекса России , а также работаем в рамках 275 ФЗ с открытием отдельных счетов в уполномоченном банке. Система менеджмента качества компании соответствует требованиям ГОСТ ISO 9001.

Минимальные сроки поставки, гибкие цены, неограниченный ассортимент и индивидуальный подход к клиентам являются основой для выстраивания долгосрочного и эффективного сотрудничества с предприятиями радиоэлектронной промышленности, предприятиями ВПК и научно-исследовательскими институтами России.

С нами вы становитесь еще успешнее!

Наши контакты:

Телефон: +7 812 627 14 35

Электронная почта: sales@st-electron.ru

Адрес: 198099, Санкт-Петербург,
Промышленная ул, дом № 19, литера Н,
помещение 100-Н Офис 331