

BROADCAST ANALOG TUNING DIGITAL DISPLAY AM/FM/SW RADIO RECEIVER

Features

- Worldwide FM band support (64–109 MHz)
 - Worldwide AM band support (504–1750 kHz)
 - SW band support (Si4826 only) (2.3–28.5 MHz)
 - Selectable support for all AM/FM/SW regional bands
 - 2-wire control interface
 - Mono output
 - Valid station indicator
 - Digital volume support
 - Bass/Treble support
 - Minimal BOM components with no manual alignment
 - Excellent real-world performance
 - Automatic frequency control (AFC)
 - Two AAA batteries with 2.0 to 3.6 V supply voltage (T = 25 °C)
 - Wide range of ferrite loop sticks and air loop antenna support
 - 24-pin SSOP package
 - RoHS compliant
 - Not EN55020 compliant *
- *Note:** For consumer applications that require EN 55020 compliance, use Si4840/44.

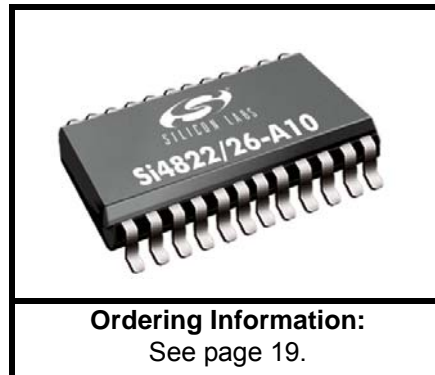

Applications

- Table and portable radios
- Boom boxes
- Clock radios
- Modules for consumer electronics
- Toys, lamps, and any application needing an AM/FM radio

Description

The Si4822/26 is the entry level analog-tuned digital-display digital CMOS AM/FM/SW radio receiver IC that integrates the complete receiver function from antenna input to audio output. Working with Host MCU (I²C-compatible 2-wire control interface), frequencies information can be displayed on LCD, while the analog-tune features are kept. Leveraging Silicon Laboratories' proven and patented digital low intermediate frequency (low-IF) receiver architecture, the Si4822/26 delivers superior RF performance and interference rejection. The superior control algorithm integrated in Si4822/26 provides easy and reliable control interface while eliminating all the manual tuned external components used in traditional solutions.

Functional Block Diagram

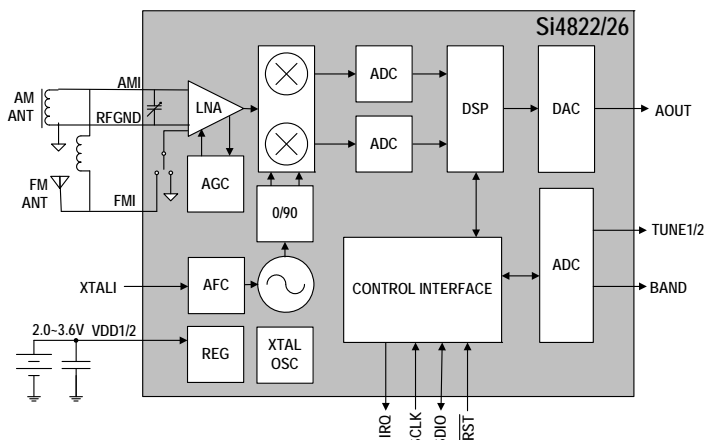

Pin Assignments

Si4822/26-A10 (SSOP)

LNA_EN	1	●	24	AOUT
IRQ	2		23	NC
TUNE1	3		22	DBYP
TUNE2	4		21	VDD2
BAND	5		20	VDD1
NC	6		19	XTALI
NC	7		18	XTALO
FMI	8		17	SCLK
RFGND	9		16	SDIO
NC	10		15	RST
NC	11		14	GND
AMI	12		13	GND

This product, its features, and/or its architecture is covered by one or more of the following patents, as well as other patents, pending and issued, both foreign and domestic: 7,127,217; 7,272,373; 7,272,375; 7,321,324; 7,355,476; 7,426,376; 7,471,940; 7,339,503; 7,339,504.

TABLE OF CONTENTS

<u>Section</u>	<u>Page</u>
1. Electrical Specifications	4
2. Typical Application Schematic	11
3. Bill of Materials	12
4. Functional Description	13
4.1. Overview	13
4.2. FM Receiver	14
4.3. AM Receiver	14
4.4. SW Receiver	14
4.5. Frequency Tuning	14
4.6. Band Select	14
4.7. Bass and Treble	15
4.8. Volume Control	15
4.9. High Fidelity DAC	15
4.10. Soft Mute	15
4.11. Reference Clock	15
4.12. Memorizing Status	15
4.13. Programming with Commands	15
5. Commands and Properties	16
6. Pin Descriptions	18
6.1. Si4822/26-A10	18
7. Ordering Guide	19
8. Package Outline: Si4822/26-A10	20
9. PCB Land Pattern: Si4822/26-A10	21
10. Top Markings	22
10.1. Si4822/26-A10 Top Mark	22
11. Additional Reference Resources	23
Contact Information	24

Si4822/26-A10

1. Electrical Specifications

Table 1. Recommended Operating Conditions^{1,2}

Parameter	Symbol	Test Condition	Min	Typ	Max	Unit
Supply Voltage ³	V_{DD}		2.0	—	3.6	V
Power Supply Powerup Rise Time	V_{DDRISE}		10	—	—	μ s

Notes:

1. Typical values in the data sheet apply at $V_{DD} = 3.3$ V and 25 °C unless otherwise stated.
2. All minimum and maximum specifications in the data sheet apply across the recommended operating conditions for minimum $V_{DD} = 2.7$ V.
3. Operation at minimum V_{DD} is guaranteed by characterization when V_{DD} voltage is ramped down to 2.0 V. Part initialization may become unresponsive below 2.3 V.

Table 2. DC Characteristics

($V_{DD} = 2.7$ to 3.6 V, $T_A = 0$ to 70 °C)

Parameter	Symbol	Test Condition	Min	Typ	Max	Unit
FM Mode						
Supply Current ¹	I_{FM}		—	21.0	—	mA
Supply Current ²	I_{FM}	Low SNR level	—	21.5	—	mA
AM/SW Mode						
Supply Current ¹	I_{AM}		—	17.0	—	mA
Supplies and Interface						
V_{DD} Powerdown Current	I_{DDPD}		—	10	—	μ A

Notes:

1. Specifications are guaranteed by characterization.
2. LNA is automatically switched to higher current mode for optimum sensitivity in weak signal conditions.

Table 3. Reset Timing Characteristics $(V_{DD} = 2.7 \text{ to } 3.6 \text{ V}, T_A = 0 \text{ to } 70 \text{ }^\circ\text{C})$

Parameter	Symbol	Min	Typ	Max	Unit
$\overline{\text{RST}}$ Pulse Width	t_{SRST}	100	—	—	μs

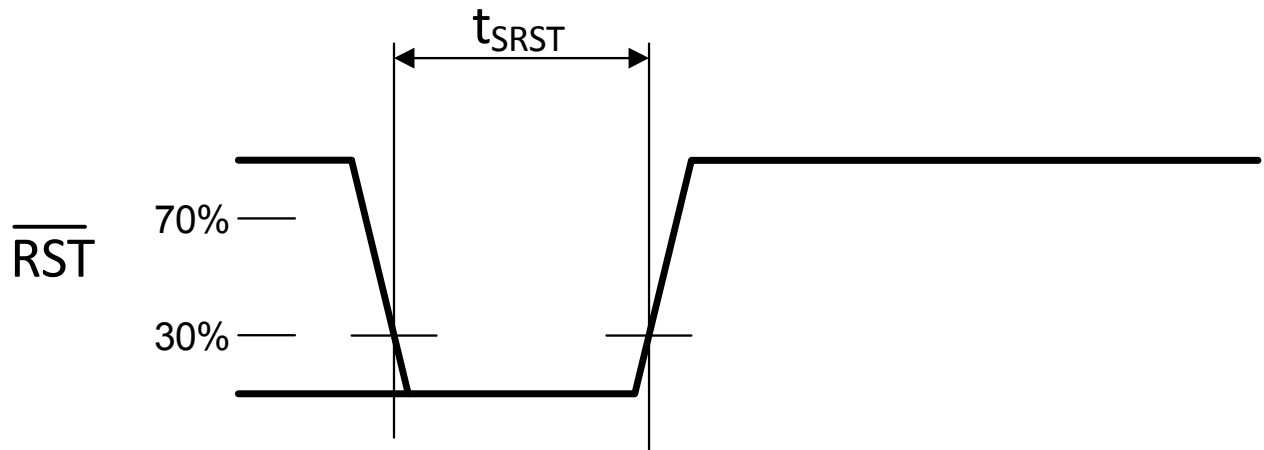
**Figure 1. Reset Timing**

Si4822/26-A10

Table 4. 2-Wire Control Interface Characteristics^{1,2,3}

(V_{DD} = 2.7 to 3.6 V, T_A = 0 to 70 °C)

Parameter	Symbol	Test Condition	Min	Typ	Max	Unit
SCLK Frequency	f _{SCLK}		0	—	400	kHz
SCLK Low Time	t _{LOW}		1.3	—	—	μs
SCLK High Time	t _{HIGH}		0.6	—	—	μs
SCLK Input to SDIO ↓ Setup (START)	t _{SU:STA}		0.6	—	—	μs
SCLK Input to SDIO ↓ Hold (START)	t _{HD:STA}		0.6	—	—	μs
SDIO Input to SCLK ↑ Setup	t _{SU:DAT}		100	—	—	ns
SDIO Input to SCLK ↓ Hold ^{4,5}	t _{HD:DAT}		0	—	900	ns
SCLK input to SDIO ↑ Setup (STOP)	t _{SU:STO}		0.6	—	—	μs
STOP to START Time	t _{BUF}		1.3	—	—	μs
SDIO Output Fall Time	t _{f:OUT}		$20 + 0.1 \frac{C_b}{1\text{pF}}$	—	250	ns
SDIO Input, SCLK Rise/Fall Time	t _{f:IN} t _{r:IN}		$20 + 0.1 \frac{C_b}{1\text{pF}}$	—	300	ns
SCLK, SDIO Capacitive Loading	C _b		—	—	50	pF
Input Filter Pulse Suppression	t _{SP}		—	—	50	ns

Notes:

1. When V_D = 0 V, SCLK and SDIO are low impedance.
2. When selecting 2-wire mode, the user must ensure that a 2-wire start condition (falling edge of SDIO while SCLK is high) does not occur within 300 ns before the rising edge of $\overline{\text{RST}}$.
3. When selecting 2-wire mode, the user must ensure that SCLK is high during the rising edge of $\overline{\text{RST}}$, and stays high until after the first start condition.
4. The Si4822/26 delays SDIO by a minimum of 300 ns from the V_{IH} threshold of SCLK to comply with the minimum t_{HD:DAT} specification.
5. The maximum t_{HD:DAT} has only to be met when f_{SCLK} = 400 kHz. At frequencies below 400 kHz, t_{HD:DAT} may be violated as long as all other timing parameters are met.

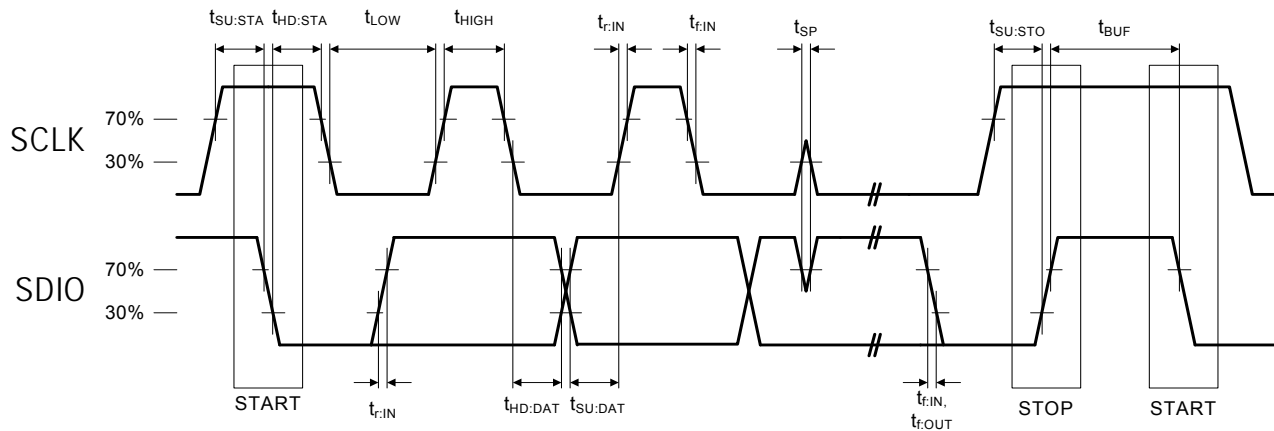

Figure 2. 2-Wire Control Interface Read and Write Timing Parameters

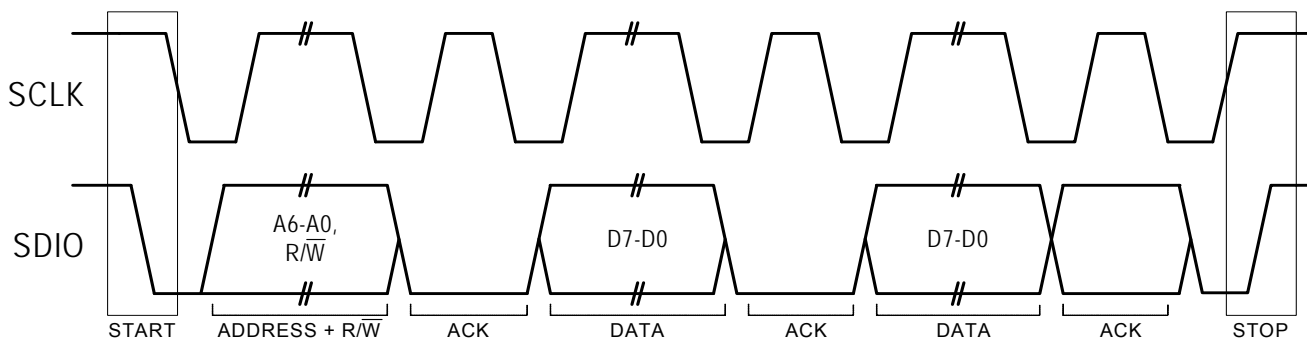

Figure 3. 2-Wire Control Interface Read and Write Timing Diagram

Si4822/26-A10

Table 5. FM Receiver Characteristics^{1,2}

($V_{DD} = 2.7$ to 3.6 V, $T_A = 0$ to 70 °C)

Parameter	Symbol	Test Condition	Min	Typ	Max	Unit
Input Frequency	f_{RF}		64	—	109	MHz
Sensitivity with Headphone Network ³		(S+N)/N = 26 dB	—	4.0	—	μ V EMF
LNA Input Resistance ^{4,5}			—	4	—	k Ω
LNA Input Capacitance ^{4,5}			—	5	—	pF
AM Suppression ^{4,5,6,7}		m = 0.3	—	50	—	dB
Input IP ₃ ^{4,8}			—	105	—	dB μ V EMF
Adjacent Channel Selectivity ⁴		± 200 kHz	—	45	—	dB
Alternate Channel Selectivity ⁴		± 400 kHz	—	60	—	dB
Audio Output Voltage ^{5,6,7,12}			—	72	—	mV _{RMS}
Audio Mono S/N ^{5,6,7,9,10}			—	45	—	dB
Audio Frequency Response Low ⁴		-3 dB	—	—	30	Hz
Audio Frequency Response High ⁴		-3 dB	15	—	—	kHz
Audio THD ^{5,6,11}			—	0.1	0.5	%
Audio Output Load Resistance ^{4,10}	R_L	Single-ended	10	—	—	k Ω
Audio Output Load Capacitance ^{4,10}	C_L	Single-ended	—	—	50	pF
Powerup/Band Switch Time ⁴			—	—	110	ms

Notes:

1. Additional testing information is available in "AN603: Si4822/26/40/44 DEMO Board Test Procedure." Volume = maximum for all tests. Tested at RF = 98.1 MHz.
2. To ensure proper operation and receiver performance, follow the guidelines in "AN602: Si4822/26/40/44 Antenna, Schematic, Layout, and Design Guidelines." Silicon Laboratories will evaluate schematics and layouts for qualified customers.
3. Frequency is 64~109 MHz.
4. Guaranteed by characterization.
5. $V_{EMF} = 1$ mV.
6. $F_{MOD} = 1$ kHz, MONO, and L = R unless noted otherwise.
7. $\Delta f = 22.5$ kHz.
8. $|f_2 - f_1| > 2$ MHz, $f_0 = 2 \times f_1 - f_2$.
9. $B_{AF} = 300$ Hz to 15 kHz, A-weighted.
10. At A_{OUT} pin.
11. $\Delta f = 75$ kHz.
12. Tested in Digital Volume Mode.

Table 6. AM/SW Receiver Characteristics^{1, 2}(V_{DD} = 2.7 to 3.6 V, T_A = 0 to 70 °C)

Parameter	Symbol	Test Condition	Min	Typ	Max	Unit
Input Frequency	f _{RF}	Medium Wave (AM)	504	—	1750	kHz
		Short Wave (SW)	2.3	—	28.5	MHz
Sensitivity ^{3,4,5}		(S+N)/N = 26 dB	—	30	—	μV EMF
Large Signal Voltage Handling ⁵		THD < 8%	—	300	—	mV _{RMS}
Power Supply Rejection Ratio ⁵		ΔV _{DD} = 100 mV _{RMS} , 100 Hz	—	40	—	dB
Audio Output Voltage ^{3,6,8}			—	54	—	mV _{RMS}
Audio S/N ^{3,4,6}			—	45	—	dB
Audio THD ^{3,6}			—	0.1	—	%
Antenna Inductance ^{5,7}			180	—	450	μH
Powerup/Band Switch Time ⁵		From powerdown	—	—	110	ms

Notes:

1. Additional testing information is available in “AN603: Si4822/26/40/44 DEMO Board Test Procedure.” Volume = maximum for all tests. Tested at RF = 520 kHz.
2. To ensure proper operation and receiver performance, follow the guidelines in “AN602: Si4822/26/40/44 Antenna, Schematic, Layout, and Design Guidelines.” Silicon Laboratories will evaluate schematics and layouts for qualified customers.
3. F_{MOD} = 1 kHz, 30% modulation, 2 kHz channel filter.
4. B_{AF} = 300 Hz to 15 kHz, A-weighted.
5. Guaranteed by characterization.
6. V_{IN} = 5 mV_{rms}.
7. Stray capacitance on antenna and board must be < 10 pF to achieve full tuning range at higher inductance levels.
8. Tested in Digital Volume Mode.

Table 7. Reference Clock and Crystal Characteristics(V_{DD} = 2.7 to 3.6 V, T_A = 0 to 70 °C)

Parameter	Symbol	Test Condition	Min	Typ	Max	Unit
Reference Clock						
XTALI Supported Reference Clock Frequencies			—	32.768	—	kHz
Reference Clock Frequency Tolerance for XTALI			-100	—	100	ppm
Crystal Oscillator						
Crystal Oscillator Frequency			—	32.768	—	kHz
Crystal Frequency Tolerance			-100	—	100	ppm
Board Capacitance			—	—	3.5	pF

Table 8. Thermal Conditions

Parameter	Symbol	Min	Typ	Max	Unit
Thermal Resistance*	θ_{JA}	—	80	—	°C/W
Ambient Temperature	T_A	0	25	70	°C
Junction Temperature	T_J	—	—	77	°C

***Note:** Thermal resistance assumes a multi-layer PCB with the exposed pad soldered to a topside PCB pad.

Table 9. Absolute Maximum Ratings^{1,2}

Parameter	Symbol	Value	Unit
Supply Voltage	V_{DD}	-0.5 to 5.8	V
Input Current ³	I_{IN}	10	mA
Operating Temperature	T_{OP}	-40 to 95	°C
Storage Temperature	T_{STG}	-55 to 150	°C
RF Input Level ⁴		0.4	V_{PK}

Notes:

1. Permanent device damage may occur if the above Absolute Maximum Ratings are exceeded. Functional operation should be restricted to the conditions as specified in the operational sections of this data sheet. Exposure beyond recommended operating conditions for extended periods may affect device reliability.
2. The Si4822/26-A10 devices are high-performance RF integrated circuits with certain pins having an ESD rating of < 2 kV HBM. Handling and assembly of these devices should only be done at ESD-protected workstations.
3. For input pins RST, SDIO, SCLK, XTALO, XTALI, BAND, TUNE2, TUNE1, IRQ, and LNA_EN.
4. At RF input pins, FMI, and AMI.

2. Typical Application Schematic

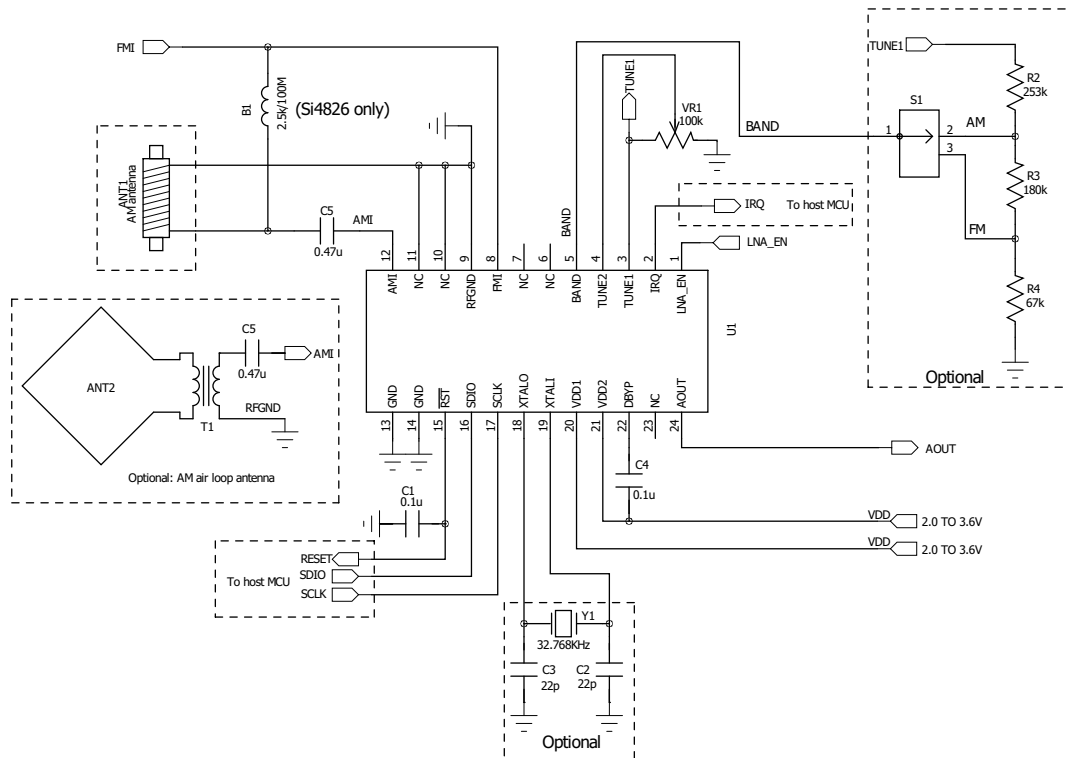

Notes:

- Place C4 close to VDD2 and DBYP pins.
- All grounds connect directly to GND plane on PCB.
- Pin 6, Pin 7, and Pin 23 leave floating.
- To ensure proper operation and receiver performance, follow the guidelines in "AN602: Si4822/26/40/44 Antenna, Schematic, Layout, and Design Guidelines." Silicon Labs will evaluate the schematics and layouts for qualified customers.
- Pin 8 connects to the FM antenna interface and pin 12 connects to the AM antenna interface.
- Place Si4822/26 as close as possible to antenna jack and keep the FMI and AMI traces as short as possible.
- Recommend keeping the AM ferrite loop antenna at least 5 cm away from the Si4822/26.
- Keep the AM ferrite loop antenna at least 5 cm away from MCU, audio amplifier, and other circuits which have AM interference.
- Place the transformer T1 away from any sources of interference and even away from the I/O signals of the Si4822/26.

3. Bill of Materials

Table 10. Si4822/26-A10 Bill of Materials

Component(s)	Value/Description	Supplier
C1	Reset capacitor 0.1 μ F, \pm 20%, Z5U/X7R	Murata
C4	Supply bypass capacitor, 0.1 μ F, \pm 20%, Z5U/X7R	Murata
C5	Coupling capacitor, 0.47 μ F, \pm 20%, Z5U/X7R	Murata
B1	Ferrite bead 2.5 k/100 MHz	Murata
VR1	Variable resistor (POT), 100 k, \pm 10%	Kennon
U1	Si4822/26 AM/FM/SW Analog Tune Digital Display Radio Tuner	Silicon Laboratories
ANT1	Ferrite stick, 180–450 μ H	Jiaxin
Optional Components		
C2, C3	Crystal load capacitors, 22 pF, \pm 5%, COG (Optional: for crystal oscillator option)	Venkel
Y1	32.768 kHz crystal (Optional: for crystal oscillator option)	Epson or equivalent
ANT2	Air loop antenna, 10–20 μ H	Various
S1	Band switch	Any, depends on customer
R2	Resistor, 253 k, \pm 1%,	Venkel
R3	Resistor, 180 k, \pm 1%	Venkel
R4	Resistor, 67 k, \pm 1%	Venkel

4. Functional Description

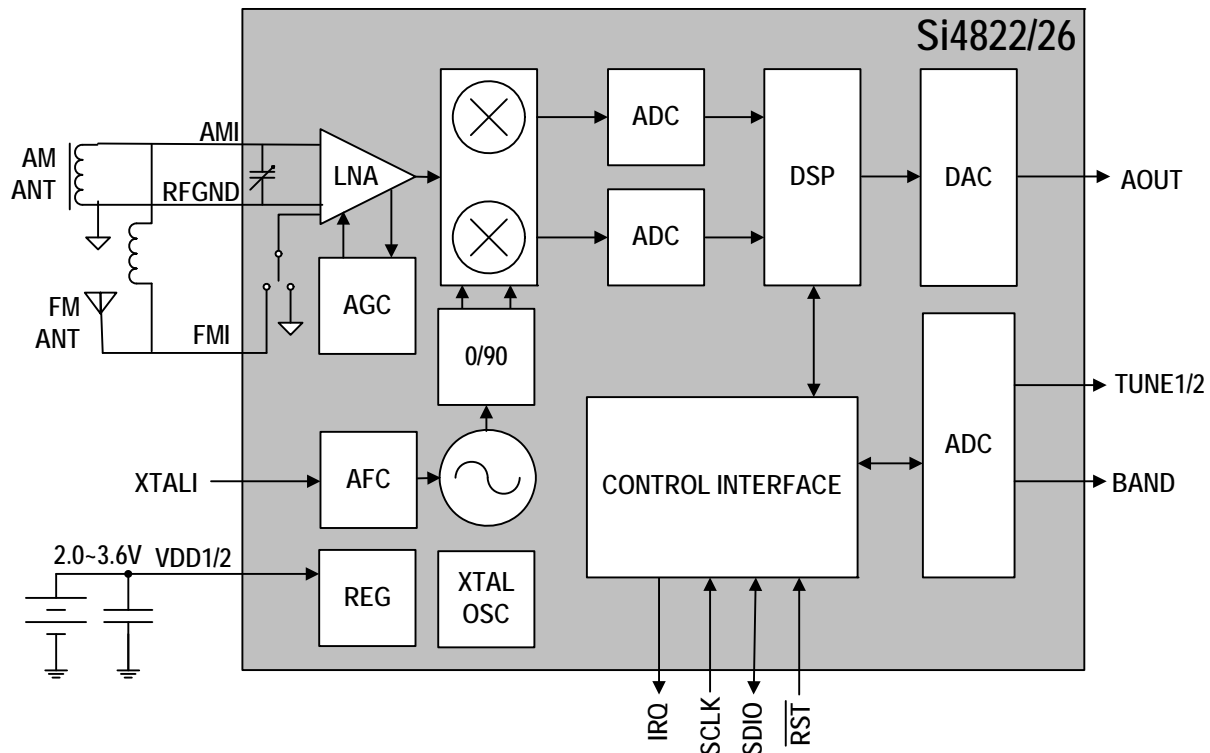

Figure 4. Si4822/26-A10 Functional Block Diagram

4.1. Overview

The Si4822/26-A10 is the entry level analog-tuned digital-display digital CMOS AM/FM/SW radio receiver IC that integrates the complete receiver function from antenna input to audio output. Working with an external MCU with LCD/LED driver, Si4822/26 can output the AM/FM/SW frequencies and band and volume information to display on LCD/LED, while using a simple potentiometer at the front end for analog-tune. Leveraging Silicon Laboratories' proven and patented digital low intermediate frequency (low-IF) receiver architecture, the Si4822/26 delivers superior RF performance and interference rejection in AM, FM and SW bands. Additionally, the digital core provides advanced audio conditioning for all environments, removing pops, clicks, and loud static in variable signal conditions. The superior control algorithm integrated in Si4822/26 provides easy and reliable control interface while eliminating all the manual tuned external components used in traditional solutions.

Like other successful audio products from Silicon Labs, Si4822/26 offers unmatched integration and PCB space savings with minimum external components and a small board area on a single side PCB. The high integration and complete system production test simplifies design-in, increases system quality, and improves manufacturability. The receiver has very low power consumption, runs off two AAA batteries, and delivers the performance benefits of high performance digital radio experience with digital display to the legacy analog-tuned radio market.

The Si4822/26 provides good flexibility in using the chip. The frequency range of FM/AM/SW bands, de-emphasis value, AM tuning step, and AM soft mute level/rate can be either configured by the MCU or by using external hardware to make a selection. The reference clock of the FM tuner can be provided by either the crystal or by the host MCU within tolerance.

The Si4822/26 also has flexibility in selecting bands and configuring band properties, enabling masked Host MCU for multiple projects, and reducing the cost of development. Four tuning preferences are available to meet different tuning preference requirements.

4.2. FM Receiver

The Si4822/26-A10 integrates a low noise amplifier (LNA) supporting the worldwide FM broadcast band (64 to 109 MHz).

Pre-emphasis and de-emphasis is a technique used by FM broadcasters to improve the signal-to-noise ratio of FM receivers by reducing the effects of high frequency interference and noise. When the FM signal is transmitted, a pre-emphasis filter is applied to accentuate the high audio frequencies. All FM receivers incorporate a de-emphasis filter which attenuates high frequencies to restore a flat frequency response. Two time constants are used in various regions. The de-emphasis time constant can be chosen to be 50 or 75 μ s. Refer to "AN602: Si4822/26/40/44 Antenna, Schematic, Layout, and Design Guidelines."

4.3. AM Receiver

The highly integrated Si4822/26-A10 supports worldwide AM band reception from 504 to 1750 kHz with five sub-bands using a digital low-IF architecture with a minimum number of external components and no manual alignment required. This patented architecture allows for high-precision filtering, offering excellent selectivity and SNR with minimum variation across the AM band. Similar to the FM receiver, the Si4822/26-A10 optimizes sensitivity and rejection of strong interferers, allowing better reception of weak stations.

To offer maximum flexibility, the receiver supports a wide range of ferrite loop sticks from 180–450 μ H. An air loop antenna is supported by using a transformer to increase the effective inductance from the air loop. Using a 1:5 turn ratio inductor, the inductance is increased by 25 times and easily supports all typical AM air loop antennas, which generally vary between 10 and 20 μ H.

A 9, 10 kHz tuning step can be chosen by the external resistor or host MCU according to the different regions, and AM soft mute level can be programmed by the host MCU to have different tuning experiences. Refer to "AN610: Si4822/26/40/44 Programming Guide" and "AN602: Si4822/26/40/44 Antenna, Schematic, Layout, and Design Guidelines" for more details.

4.4. SW Receiver

The Si4826 supports short wave band receptions from 2.3 to 28.5 MHz in 5 kHz step size increments. Si4826 supports extensive short wave features such as minimal discrete components and no factory adjustments. The Si4826 supports using the FM antenna to capture short wave signals. Refer to "AN610: Si4822/26/40/44 Programming Guide" and "AN602: Si4822/26/40/44 Antenna, Schematic, Layout, and Design Guidelines" for more details.

4.5. Frequency Tuning

A valid channel can be found by tuning the potentiometer that is connected to the TUNE1 and TUNE2 pin of the Si4822/26-A10 chip.

To offer easy tuning, the Si4822/26-A10 also outputs the tuned information to the MCU with LCD/LED driver to display. It will light up the icon on display if the RF signal quality passes a certain threshold when tuned to a valid station. Refer to "AN610: Si4822/26/40/44 Programming Guide" for more details.

4.6. Band Select

The Si4822/26-A10 supports worldwide AM band with five sub-bands, US/Europe/Japan/China FM band with five sub-bands, and SW band with 16 sub-bands. Si4822/26-A10 provides the flexibility to configure the band and band properties at either the MCU side or the tuner side, enabling masked MCU for multiple projects. For details on band selection, refer to "AN602: Si4822/26/40/44 Antenna, Schematic, Layout, and Design Guidelines" and "AN610: Si4822/26/40/44 Programming Guide".

4.7. Bass and Treble

The Si4822/26-A10 further supports Bass/Treble tone control for superior sound quality. The Si4822/26-A10 can be set to be default normal, or programmed by the host MCU I²C-compatible 2-wire mode. FM has nine levels Bass/Treble effect and AM/SW has seven levels Bass/Treble effect. For further configuration details, refer to "AN610: Si4822/26/40/44 Programming Guide".

4.8. Volume Control

The Si4822/26-A10 not only allows users to use the traditional PVR wheel volume control through an external speaker amplifier, it also supports digital volume control programmed by the host MCU. Si4822/26-A10 can be programmed to be Bass/Treble mode only or digital volume mode only; it can also be programmed to have the digital volume coexist with Bass/Treble in two modes. Refer to "AN610: Si4822/26/40/44 Programming Guide" and "AN602: Si4822/26/40/44 Antenna, Schematic, Layout, and Design Guidelines" for more details.

4.9. High Fidelity DAC

High-fidelity digital-to-analog converters (DACs) drive analog audio signals onto the AOUT pin. The audio output may be muted.

4.10. Soft Mute

The soft mute feature is available to attenuate the audio outputs and minimize audible noise in very weak signal conditions. Advanced algorithm is implemented to get a better analog tuning experience. The soft mute feature is triggered by the SNR metric. The SNR threshold for activating soft mute is programmable, as are soft mute attenuation levels and attack and decay rates.

4.11. Reference Clock

The Si4822/26-A10 supports RCLK input (to XTALI pin) with the spec listed in Table 7. It can be shared with the host MCU to save extra crystal.

An onboard crystal oscillator is available to generate the 32.768 kHz reference when an external crystal and load capacitors are provided. Refer to "AN602: Si4822/26/40/44 Antenna, Schematic, Layout, and Design Guidelines" for more details.

4.12. Memorizing Status

The Si4822/26-A10 provides the feature to memorize status from the last power down with a simple design on PCB, including frequency of the FM/AM/SW station. Refer to "AN602: Si4822/26/40/44 Antenna, Schematic, Layout, and Design Guidelines" for details.

4.13. Programming with Commands

To ease development time and offer maximum customization, the Si4822/26 provides a simple yet powerful software interface to program the receiver. The device is programmed using commands, arguments, properties, and responses.

To perform an action, the user writes a command byte and associated arguments, causing the chip to execute the given command. Commands control an action such as powerup the device, shut down the device, or get the current tuned frequency. Arguments are specific to a given command and are used to modify the command.

Properties are a special command argument used to modify the default chip operation and are generally configured immediately after powerup. Examples of properties are de-emphasis level and soft mute attenuation threshold.

Responses provide the user information and are echoed after a command and associated arguments are issued. All commands provide a 1-byte status update, indicating interrupt and clear-to-send status information.

For a detailed description of the commands and properties for the Si4822/26, see "AN610: Si4822/26/40/44 Programming Guide".

5. Commands and Properties

Table 11. Si4822/26-A10 FM Receiver Command Summary

Cmd	Name	Description
0xE0	ATDD_GET_STATUS	Get tune freq, band and etc status of the device
0xE1	ATDD_POWER_UP	Power up device, band selection and band properties setup
0xE2	ATDD_AUDIO_MODE	Audio output mode: get/set audio mode and settings
0x10	GET_REV	Returns the revision information of the device.
0x11	POWER_DOWN	Power down device.
0x12	SET_PROPERTY	Sets the value of a property.
0x13	GET_PROPERTY	Retrieve a property's value.

Note: The Si4822/26 has its own power up and get status commands which is different from previous si47xx tuner parts. To differentiate, we use "ATDD_POWER_UP" and ATDD_GET_STATUS to denote the ATDD specific commands instead of the general si47xx "POWER_UP" and "STATUS" commands

Table 12. Si4822/26-A10 FM Receiver Property Summary

Prop	Name	Description	Default
0x1100	FM_DEEMPHASIS	Sets deemphasis time constant. Default is 75 μ s.	0x0002
0x1300	FM_SOFT_MUTE_RATE	Sets the attack and decay rates when entering and leaving soft mute.	0x0040
0x1301	FM_SOFT_MUTE_SLOPE	Configures attenuation slope during soft mute in dB attenuation per dB SNR below the soft mute SNR threshold. Default value is 2.	0x0002
0x1302	FM_SOFT_MUTE_MAX_ATTENUATION	Sets maximum attenuation during soft mute (dB). Set to 0 to disable soft mute. Default is 16 dB.	0x0010
0x1303	FM_SOFT_MUTE_SNR_THRESHOLD	Sets SNR threshold to engage soft mute. Default is 4 dB.	0x0004
0x4000	RX_VOLUME	Sets the output volume.	0x003F
0x4001	RX_HARD_MUTE	Mutes the audio output.	0x0000
0x4002	RX_BASS_TREBLE	Sets the output bass/treble level	0x0004
0x4003	RX_ACTUAL_VOLUME	Read the actual output volume	0x003F

Table 13. Si4822/26-A10 AM/SW Receiver Command Summary

Cmd	Name	Description
0xE0	ATDD_GET_STATUS	Get tune freq, band and etc status of the device
0xE1	ATDD_POWER_UP	Power up device, band selection and band properties setup
0xE2	ATDD_AUDIO_MODE	Audio output mode: get/set audio mode settings.
0x10	GET_REV	Returns the revision information of the device.
0x11	POWER_DOWN	Power down device.
0x12	SET_PROPERTY	Sets the value of a property.
0x13	GET_PROPERTY	Retrieve a property's value.

Note: The Si4822/26 has its own power up and get status commands which is different from previous si47xx tuner parts. To differentiate, we use "ATDD_POWER_UP" and ATDD_GET_STATUS to denote the ATDD specific commands instead of the general Si47xx "POWER_UP" and "STATUS" commands.

Table 14. Si4822/26-A10 AM/SW Receiver Property Summary

Prop	Name	Description	Default
0x4000	RX_VOLUME	Sets the output volume.	0x003F
0x4001	RX_HARD_MUTE	Mutes the audio output.	0x0000
0x4002	RX_BASS_TREBLE	Sets the output bass/treble level	0x0003
0x4003	RX_ACTUAL_VOLUME	Read the actual output volume	0x003F
0x3300	AM_SOFT_MUTE_RATE	Sets the attack and decay rates when entering and leaving soft mute.	0x0040
0x3301	AM_SOFT_MUTE_SLOPE	Configures attenuation slope during soft mute in dB attenuation per dB SNR below the soft mute SNR threshold.	0x0002
0x3302	AM_SOFT_MUTE_MAX_ATTENUATION	Sets maximum attenuation during soft mute (dB). Set to 0 to disable soft mute.	0x0010
0x3303	AM_SOFT_MUTE_SNR_THRESHOLD	Sets SNR threshold to engage soft mute.	0x0008

Si4822/26-A10

6. Pin Descriptions

6.1. Si4822/26-A10

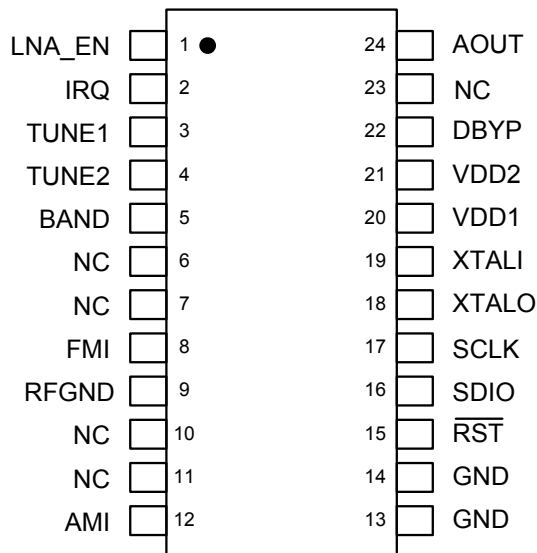

Pin Number(s)	Name	Description
1	LNA_EN	Enabling SW external LNA for Si4826
2	IRQ	Interrupt Request
3	TUNE1	Frequency tuning
4	TUNE2	Frequency tuning
5	BAND	Band selection and de-emphasis selection
6,7	NC	No connect. Leave floating.
8	FMI	FM RF inputs. FMI should be connected to the antenna trace.
9	RFGND	RF ground. Connect to ground plane on PCB.
10, 11	NC	Unused. Tie these pins to GND.
12	AMI	AM RF input. AMI should be connected to the AM antenna.
13, 14	GND	Ground. Connect to ground plane on PCB.
15	$\overline{\text{RST}}$	Device reset (active low) input
16	SDIO	Serial data input/output
17	SCLK	Serial clock input
18	XTALO	Crystal oscillator output
19	XTALI	Crystal oscillator input
20	VDD1	Supply voltage. May be connected directly to battery.
21	VDD2	Supply voltage. May be connected directly to battery.
22	DBYP	Dedicated bypass for VDD
23	NC	No connect. Leave floating.
24	AOUT	Audio output

7. Ordering Guide

Part Number ^{1,2}	Description	Package Type	Operating Temperature/Voltage
Si4822-A10-CU	AM/FM Broadcast Analog Tune Digital Display Radio Receiver	24L SSOP Pb-free	0 to 70 °C 2.0 to 3.6 V
Si4826-A10-CU	AM/FM/SW Broadcast Analog Tune Digital Display Radio Receiver	24L SSOP Pb-free	0 to 70 °C 2.0 to 3.6 V

Notes:

1. Add an "(R)" at the end of the device part number to denote tape and reel option. The devices will typically operate at 25 °C with degraded specifications for V_{DD} voltage ramped down to 2.0 V.
2. The -C suffix in the part number indicates Consumer Grade product. Visit www.silabs.com to get more information on product grade specifications.

Si4822/26-A10

8. Package Outline: Si4822/26-A10

The 24-pin SSOP illustrates the package details for the Si4822/26-A10. Table 15 lists the values for the dimensions shown in the illustration.

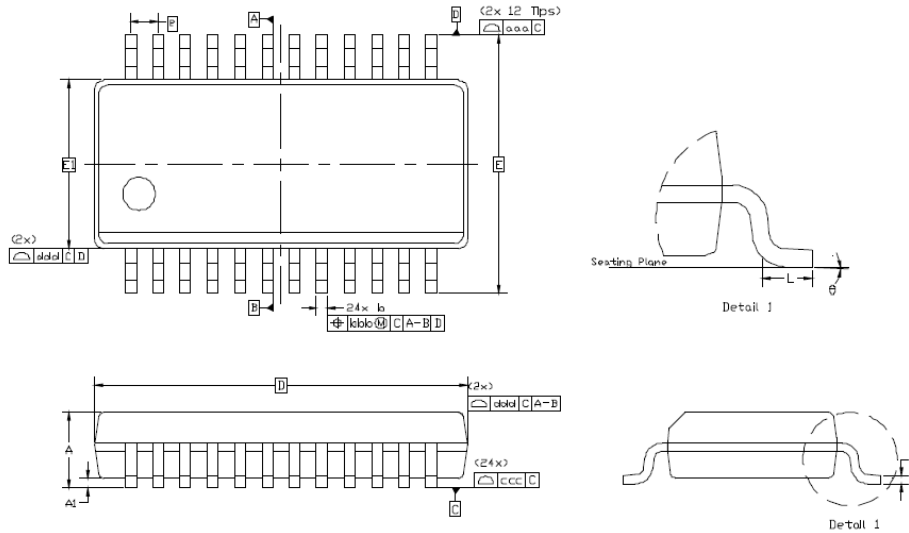

Figure 5. 24-Pin SSOP

Table 15. Package Dimensions

Dimension	Min	Nom	Max
A	—	—	1.75
A1	0.10	—	0.25
b	0.20	—	0.30
c	0.10	—	0.25
D	8.65 BSC		
E	6.00 BSC		
E1	3.90 BSC		
e	0.635 BSC		
L	0.40	—	1.27
θ	0°	—	8°
aaa	0.20		
bbb	0.18		
ccc	0.10		
ddd	0.10		
Notes:			
1. All dimensions shown are in millimeters (mm) unless otherwise noted.			
2. Dimensioning and Tolerancing per ANSI Y14.5M-1994.			
3. This drawing conforms to the JEDEC Solid State Outline MO-137, Variation AE.			
4. Recommended card reflow profile is per the JEDEC/IPC J-STD-020 specification for Small Body Components.			

9. PCB Land Pattern: Si4822/26-A10

Figure 6 illustrates the PCB land pattern details for the Si4822/26-A10-CU SSOP. Table 16 lists the values for the dimensions shown in the illustration.

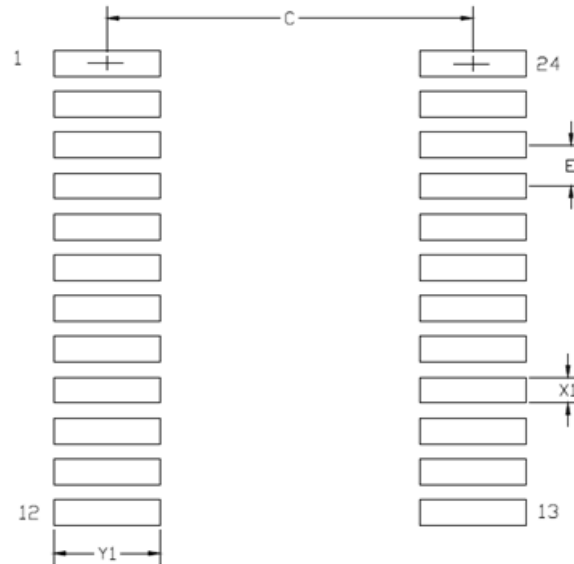

Figure 6. PCB Land Pattern

Table 16. PCB Land Pattern Dimensions

Dimension	Min	Max
C	5.20	5.40
E	0.635 BSC	
X1	0.35	0.45
Y1	1.55	1.75

General:

- All dimensions shown are in millimeters (mm) unless otherwise noted.
- This land pattern design is based on the IPC-7351 guidelines.

Solder Mask Design:

- All metal pads are to be non-solder mask defined (NSMD). Clearance between the solder mask and the metal pad is to be 60 μm minimum, all the way around the pad.

Stencil Design:

- A stainless steel, laser-cut, and electro-polished stencil with trapezoidal walls should be used to assure good solder paste release.
- The stencil thickness should be 0.125 mm (5 mils).
- The ratio of stencil aperture to land pad size should be 1:1 for all perimeter pads.

Card Assembly:

- A No-Clean, Type-3 solder paste is recommended.
- The recommended card reflow profile is per the JEDEC/IPC J-STD-020 specification for Small Body Components.

Si4822/26-A10

10. Top Markings

10.1. Si4822/26-A10 Top Marking

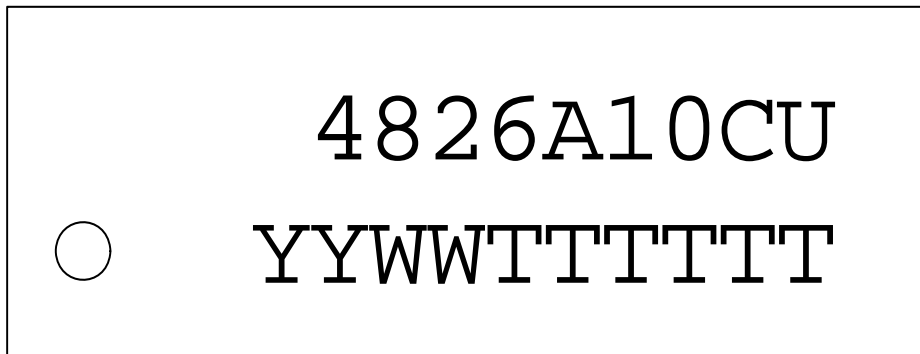
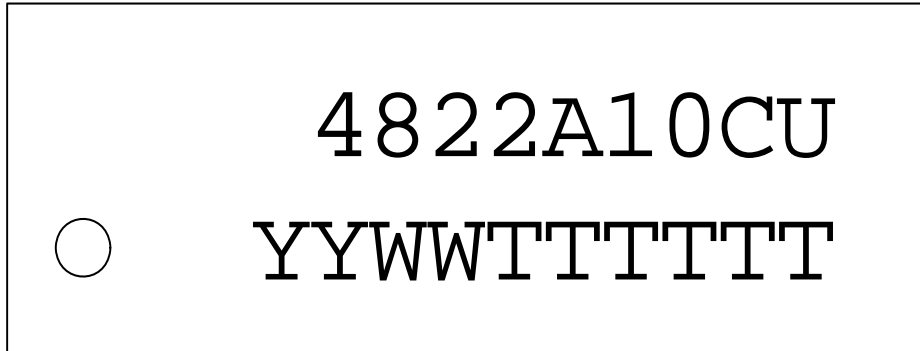

10.2. Top Marking Explanation

Mark Method:	YAG Laser	
Line 1 Marking:	Device identifier	4822A10CU = Si4822-A10 4826A10CU = Si4826-A10
Line 2 Marking:	YY = Year WW = Work week TTTTTT = Manufacturing code	Assigned by the Assembly House.

11. Additional Reference Resources

Contact your local sales representatives for more information or to obtain copies of the following references:

- AN602: Si4822/26/40/44 Antenna, Schematic, Layout, and Design Guidelines
- AN603: Si4822/26/40/44-DEMO Board Test Procedure
- Si4822/26-DEMO Board User's Guide
- AN610: Si4822/26/40/44 Programming Guide

CONTACT INFORMATION

Silicon Laboratories Inc.

400 West Cesar Chavez
Austin, TX 78701
Tel: 1+(512) 416-8500
Fax: 1+(512) 416-9669
Toll Free: 1+(877) 444-3032
Email: FMinfo@silabs.com
Internet: www.silabs.com

The information in this document is believed to be accurate in all respects at the time of publication but is subject to change without notice. Silicon Laboratories assumes no responsibility for errors and omissions, and disclaims responsibility for any consequences resulting from the use of information included herein. Additionally, Silicon Laboratories assumes no responsibility for the functioning of undescribed features or parameters. Silicon Laboratories reserves the right to make changes without further notice. Silicon Laboratories makes no warranty, representation or guarantee regarding the suitability of its products for any particular purpose, nor does Silicon Laboratories assume any liability arising out of the application or use of any product or circuit, and specifically disclaims any and all liability, including without limitation consequential or incidental damages. Silicon Laboratories products are not designed, intended, or authorized for use in applications intended to support or sustain life, or for any other application in which the failure of the Silicon Laboratories product could create a situation where personal injury or death may occur. Should Buyer purchase or use Silicon Laboratories products for any such unintended or unauthorized application, Buyer shall indemnify and hold Silicon Laboratories harmless against all claims and damages.

Silicon Laboratories and Silicon Labs are trademarks of Silicon Laboratories Inc.
Other products or brandnames mentioned herein are trademarks or registered trademarks of their respective holders.



Стандарт Электрон Связь

Мы молодая и активно развивающаяся компания в области поставок электронных компонентов. Мы поставляем электронные компоненты отечественного и импортного производства напрямую от производителей и с крупнейших складов мира.

Благодаря сотрудничеству с мировыми поставщиками мы осуществляем комплексные и плановые поставки широчайшего спектра электронных компонентов.

Собственная эффективная логистика и склад в обеспечивает надежную поставку продукции в точно указанные сроки по всей России.

Мы осуществляем техническую поддержку нашим клиентам и предпродажную проверку качества продукции. На все поставляемые продукты мы предоставляем гарантию .

Осуществляем поставки продукции под контролем ВП МО РФ на предприятия военно-промышленного комплекса России , а также работаем в рамках 275 ФЗ с открытием отдельных счетов в уполномоченном банке. Система менеджмента качества компании соответствует требованиям ГОСТ ISO 9001.

Минимальные сроки поставки, гибкие цены, неограниченный ассортимент и индивидуальный подход к клиентам являются основой для выстраивания долгосрочного и эффективного сотрудничества с предприятиями радиоэлектронной промышленности, предприятиями ВПК и научно-исследовательскими институтами России.

С нами вы становитесь еще успешнее!

Наши контакты:

Телефон: +7 812 627 14 35

Электронная почта: sales@st-electron.ru

Адрес: 198099, Санкт-Петербург,
Промышленная ул, дом № 19, литера Н,
помещение 100-Н Офис 331