

AD7708/AD7718

FEATURES

- 8-/10-Channel, High Resolution Σ - Δ ADCs**
- AD7708 Has 16-Bit Resolution**
- AD7718 Has 24-Bit Resolution**
- Factory-Calibrated**
- Single Conversion Cycle Setting**
- Programmable Gain Front End**
- Simultaneous 50 Hz and 60 Hz Rejection**
- VREF Select™ Allows Absolute and Ratiometric Measurement Capability**
- Operation Can Be Optimized for Analog Performance (CHOP = 0) or Channel Throughput (CHOP = 1)**

INTERFACE

- 3-Wire Serial**
- SPI™, QSPI™, MICROWIRE™, and DSP-Compatible Schmitt Trigger on SCLK**

POWER

- Specified for Single 3 V and 5 V Operation**
- Normal: 1.28 mA Typ @ 3 V**
- Power-Down: 30 μ A (32 kHz Crystal Running)**
- On-Chip Functions**

- Rail-to-Rail Input Buffer and PGA**
- 2-Bit Digital I/O Port**

APPLICATIONS

- Industrial Process Control**
- Instrumentation**
- Pressure Transducers**
- Portable Instrumentation**
- Smart Transmitters**

GENERAL DESCRIPTION

The AD7708/AD7718 are complete analog front-ends for low frequency measurement applications. The AD7718 contains a 24-bit Σ - Δ ADC with PGA and can be configured as 4/5 fully-differential input channels or 8/10 pseudo-differential input channels. Two pins on the device are configurable as analog inputs or reference inputs. The AD7708 is a 16-bit version of the AD7718. Input signal ranges from 20 mV to 2.56 V can be directly converted using these ADCs. Signals can be converted directly from a transducer without the need for signal conditioning.

The device operates from a 32 kHz crystal with an on-board PLL generating the required internal operating frequency. The output data rate from the part is software programmable. The peak-to-peak resolution from the part varies with the programmed gain and output data rate.

The part operates from a single 3 V or 5 V supply. When operating from 3 V supplies, the power dissipation for the part is 3.84 mW typ. Both parts are pin-for-pin compatible allowing an upgradable path from 16 to 24 bits without the need for hardware modifications. The AD7708/AD7718 are housed in 28-lead SOIC and TSSOP packages.

FUNCTIONAL BLOCK DIAGRAM

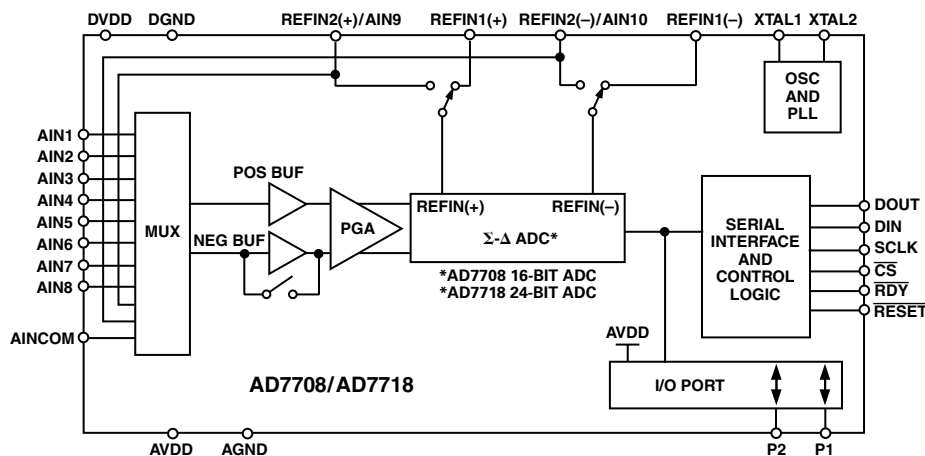

SPI and QSPI are trademarks of Motorola Inc.
MICROWIRE is a trademark of National Semiconductor Corp.
VREF Select is a trademark of Analog Devices, Inc.

REV. 0

Information furnished by Analog Devices is believed to be accurate and reliable. However, no responsibility is assumed by Analog Devices for its use, nor for any infringements of patents or other rights of third parties that may result from its use. No license is granted by implication or otherwise under any patent or patent rights of Analog Devices.

AD7708/AD7718

TABLE OF CONTENTS

FEATURES	1	User Nonprogrammable Test Registers	31
FUNCTIONAL BLOCK DIAGRAM	1	Configuring the AD7708/AD7718	32
GENERAL DESCRIPTION	1	DIGITAL INTERFACE	34
AD7718 SPECIFICATIONS	3	MICROCOMPUTER/MICROPROCESSOR INTERFACING	34
AD7708 SPECIFICATIONS	6	AD7708/AD7718 to 68HC11 Interface	34
TIMING CHARACTERISTICS	9	AD7708/AD7718-to-8051 Interface	35
ABSOLUTE MAXIMUM RATINGS	10	AD7708/AD7718-to-ADSP-2103/ADSP-2105 Interface	36
ORDERING GUIDE	10	BASIC CONFIGURATION	36
PIN FUNCTION DESCRIPTIONS	12	Analog Input Channels	37
PIN CONFIGURATION	13	Single-Ended Operation	37
ADC CIRCUIT INFORMATION	15	Chop Mode of Operation (CHOP = 0)	37
Signal Chain Overview (CHOP Enabled, CHOP = 0)	15	Nonchop Mode of Operation (CHOP = 1)	38
ADC NOISE PERFORMANCE CHOP ENABLED (CHOP = 0)	17	Programmable Gain Amplifier	38
Signal Chain Overview (CHOP Disabled CHOP = 1)	19	Bipolar/Unipolar Configuration	38
ADC NOISE PERFORMANCE CHOP DISABLED (CHOP = 1)	20	Data Output Coding	38
ON-CHIP REGISTERS	22	Oscillator Circuit	39
Communications Register	25	Reference Input	39
Status Register	26	$\overline{\text{RESET}}$ Input	39
Mode Register	27	Power-Down Mode	39
Operating Characteristics when Addressing the Mode and Control Registers	28	Calibration	40
ADC Control Register	28	Grounding and Layout	40
Filter Register	29	APPLICATIONS	41
I/O Control Register	30	Data Acquisition	41
ADC Data Result Register	30	Programmable Logic Controllers	41
Unipolar Mode	30	Converting Single-Ended Inputs	42
Bipolar Mode	31	Combined Ratiometric and Absolute Value Measurement System	42
ADC Offset Calibration Coefficient Registers	31	Optimizing Throughput while Maximizing 50 Hz and 60 Hz Rejection in a Multiplexed Data Acquisition System	43
ADC Gain Calibration Coefficient Register	31	OUTLINE DIMENSIONS	44
ID Register (ID)	31		

AD7718 SPECIFICATIONS¹

($V_{DD} = 2.7\text{ V to }3.6\text{ V or }4.75\text{ V to }5.25\text{ V}$, $DV_{DD} = 2.7\text{ V to }3.6\text{ V or }4.75\text{ V to }5.25\text{ V}$, $REFIN(+)=2.5\text{ V}$; $REFIN(-)=AGND$; $AGND=DGND=0\text{ V}$; $XTAL1/XTAL2=32.768\text{ kHz}$ Crystal Input Buffer Enabled. All specifications T_{MIN} to T_{MAX} unless otherwise noted.)

Parameter	B Grade	Unit	Test Conditions
AD7718 (CHOP DISABLED)			
Output Update Rate	16.06 1.365	Hz min kHz max	CHOP = 1
No Missing Codes ²	24	Bits min	
Resolution	13 18	Bits p-p Bits p-p	$\pm 20\text{ mV}$ Range, SF = 69 $\pm 2.56\text{ V}$ Range, SF = 69
Output Noise and Update Rates	See Tables in ADC Description		
Integral Nonlinearity Offset Error ³	± 10 Table VII	ppm of FSR max μV typ	2 ppm Typical Offset Error is in the order of the noise for the programmed gain and update rate following a calibration
Offset Error Drift vs. Temp ⁴	± 200	$\text{nV}/^\circ\text{C}$ typ	
Full-Scale Error ³	± 10	μV typ	
Gain Drift vs. Temp ⁴	± 0.5	$\text{ppm}/^\circ\text{C}$ typ	
Negative Full-Scale Error	± 0.003	% FSR max	
ANALOG INPUTS			
Differential Input Full-Scale Voltage	$\pm 1.024 \times REFIN/GAIN$	V nom	REFIN Refers to Both REFIN1 and REFIN2. $REFIN = REFIN(+)-REFIN(-)$ GAIN = 1 to 128
Absolute AIN Voltage Limits	AGND + 100 mV $AV_{DD} - 100\text{ mV}$	V min V max	AIN1–AIN10 and AINCOM with NEGBUF = 1
Absolute AINCOM Voltage Limits	AGND – 30 mV $AV_{DD} + 30\text{ mV}$	V min V max	NEGBUF = 0
Analog Input Current			AIN1–AIN10 and AINCOM with NEGBUF = 1
DC Input Current ²	± 1	nA max	
DC Bias Current Drift	± 5	$\text{pA}/^\circ\text{C}$ typ	
AINCOM Input Current			NEGBUF = 0
DC Input Current ²	± 125	nA/V typ	$\pm 2.56\text{ V}$ Range
DC Bias Current Drift	± 2	$\text{pA}/^\circ\text{C}$ typ	
Normal-Mode Rejection ²			
@ 50 Hz	100	dB min	50 Hz $\pm 1\text{ Hz}$, SF Word = 82
@ 60 Hz	100	dB min	60 Hz $\pm 1\text{ Hz}$, SF Word = 68
Common-Mode Rejection			
@ DC	90	dB min	100 dB typ, Analog Input = 1 V, Input Range = $\pm 2.56\text{ V}$
@ 50 Hz	100	dB typ	110 dB typ on $\pm 20\text{ mV}$ Range 50 Hz $\pm 1\text{ Hz}$, SF Word = 82
@ 60 Hz	100	dB typ	60 Hz $\pm 1\text{ Hz}$, SF Word = 68
REFERENCE INPUTS (REFIN1 AND REFIN2)			
REFIN(+) to REFIN(-) Voltage REFIN(+) to REFIN(-) Range ²	2.5 1 AV_{DD} AGND – 30 mV $AV_{DD} + 30\text{ mV}$	V nom V min V max V min V max	REFIN Refers to Both REFIN1 and REFIN2
REFIN Common-Mode Range			
Reference DC Input Current	0.5	$\mu\text{A}/\text{V}$ typ	
Reference DC Input Current Drift	± 0.1	$\text{nA}/^\circ\text{C}$ typ	
Normal-Mode Rejection ²			
@ 50 Hz	100	dB min	50 Hz $\pm 1\text{ Hz}$, SF Word = 82
@ 60 Hz	100	dB min	60 Hz $\pm 1\text{ Hz}$, SF Word = 68
Common-Mode Rejection			Input Range = $\pm 2.56\text{ V}$
@ DC	100	dB typ	Analog Input = 1 V. Input Range = $\pm 2.56\text{ V}$
@ 50 Hz	100	dB typ	
@ 60 Hz	100	dB typ	

AD7718—SPECIFICATIONS¹ ($V_{DD} = 2.7\text{ V to }3.6\text{ V or }4.75\text{ V to }5.25\text{ V}$, $DV_{DD} = 2.7\text{ V to }3.6\text{ V or }4.75\text{ V to }5.25\text{ V}$, $REFIN(+)$ = 2.5 V ; $REFIN(-)$ = $AGND$; $AGND = DGND = 0\text{ V}$; $XTAL1/XTAL2 = 32.768\text{ kHz}$ Crystal Input Buffer Enabled. All specifications T_{MIN} to T_{MAX} unless otherwise noted.)

Parameter	B Grade	Unit	Test Conditions
AD7718 (CHOP ENABLED)			
Output Update Rate	5.4	Hz min	$\overline{CHOP} = 0$
	105	Hz max	
No Missing Codes ²	24	Bits min	20 Hz Update Rate
Resolution	13	Bits p-p	$\pm 20\text{ mV}$ Range, 20 Hz Update Rate
	18	Bits p-p	$\pm 2.56\text{ V}$ Range, 20 Hz Update Rate
Output Noise and Update Rates	See Tables in ADC Description		
Integral Nonlinearity	± 10	ppm of FSR max	2 ppm Typical
Offset Error ³	± 3	μV typ	
Offset Error Drift vs. Temp ⁴	10	$\text{nV}/^\circ\text{C}$ typ	
Full-Scale Error ³	± 10	$\mu\text{V}/^\circ\text{C}$ typ	
Gain Drift vs. Temp ⁴	± 0.5	$\text{ppm}/^\circ\text{C}$ typ	
ANALOG INPUTS			
Differential Input Full-Scale Voltage	$\pm 1.024 \times REFIN/GAIN$	V nom	REFIN Refers to Both REFIN1 and REFIN2. $REFIN = REFIN(+)$ $REFIN(-)$ $GAIN = 1$ to 128 Analog Input = 18 mV
Range Matching	± 2	μV typ	AIN1–AIN10 and AINCOM with NEGBUF = 1
Absolute AIN Voltage Limits	$AGND + 100\text{ mV}$ $AV_{DD} - 100\text{ mV}$	V min V max	NEGBUF = 0
Absolute AINCOM Voltage Limits	$AGND - 30\text{ mV}$ $AV_{DD} + 30\text{ mV}$	V min V max	AIN1–AIN10 and AINCOM with NEGBUF = 1
Analog Input Current			
DC Input Current ²	± 1	nA max	
DC Input Current Drift	± 5	$\text{pA}/^\circ\text{C}$ typ	
AINCOM Input Current			NEGBUF = 0
DC Input Current ²	± 125	nA/V typ	$\pm 2.56\text{ V}$ Range
DC Bias Current Drift	± 2	$\text{pA}/^\circ\text{C}$ typ	
Normal-Mode Rejection ²			
@ 50 Hz	100	dB min	50 Hz $\pm 1\text{ Hz}$, SF Word = 82
@ 60 Hz	100	dB min	60 Hz $\pm 1\text{ Hz}$, SF Word = 68
Common-Mode Rejection			
@ DC	90	dB min	100 dB typ, Analog Input = 1 V, Input Range = $\pm 2.56\text{ V}$ 110 dB typ on $\pm 20\text{ mV}$ Range
@ 50 Hz ²	100	dB min	50 Hz $\pm 1\text{ Hz}$, 20 Hz Update Rate
@ 60 Hz ²	100	dB min	60 Hz $\pm 1\text{ Hz}$, 20 Hz Update Rate
REFERENCE INPUTS (REFIN1 AND REFIN2)			
REFIN(+) to REFIN(-) Voltage	2.5	V nom	REFIN Refers to Both REFIN1 and REFIN2
REFIN(+) to REFIN(-) Range ²	1	V min	
	AV_{DD}	V max	
REFIN Common-Mode Range	$AGND - 30\text{ mV}$ $AV_{DD} + 30\text{ mV}$	V min V max	
Reference DC Input Current ²	± 0.5	$\mu\text{A}/\text{V}$ typ	
Reference DC Input Current Drift	± 0.01	$\text{nA}/^\circ\text{C}$ typ	
Normal-Mode Rejection ²			
@ 50 Hz	100	dB min	50 Hz $\pm 1\text{ Hz}$, SF Word = 82
@ 60 Hz	100	dB min	60 Hz $\pm 1\text{ Hz}$, SF Word = 68
Common-Mode Rejection ²			Input Range = $\pm 2.56\text{ V}$ Analog Input = 1 V
@ DC	110	dB typ	50 Hz $\pm 1\text{ Hz}$, 20 Hz Update Rate
@ 50 Hz	110	dB typ	60 Hz $\pm 1\text{ Hz}$, 20 Hz Update Rate
@ 60 Hz	110	dB typ	
LOGIC INPUTS⁵			
All Inputs Except SCLK and XTAL1 ²			
V_{INL} , Input Low Voltage	0.8	V max	$DV_{DD} = 5\text{ V}$
V_{INL} , Input Low Voltage	0.4	V max	$DV_{DD} = 3\text{ V}$
V_{INH} , Input High Voltage	2.0	V min	$DV_{DD} = 3\text{ V or }5\text{ V}$

Parameter	B Grade	Unit	Test Conditions
LOGIC INPUTS (Continued)			
SCLK Only (Schmitt-Triggered Input) ²			
$V_{T(+)}$	1.4/2	V min/V max	DV _{DD} = 5 V
$V_{T(-)}$	0.8/1.4	V min/V max	DV _{DD} = 5 V
$V_{T(+)} - V_{T(-)}$	0.3/0.85	V min/V max	DV _{DD} = 5 V
$V_{T(+)}$	0.95/2	V min/V max	DV _{DD} = 3 V
$V_{T(-)}$	0.4/1.1	V min/V max	DV _{DD} = 3 V
$V_{T(+)} - V_{T(-)}$	0.3/0.85	V min/V max	DV _{DD} = 3 V
XTAL1 Only²			
V_{INL} , Input Low Voltage	0.8	V max	DV _{DD} = 5 V
V_{INH} , Input High Voltage	3.5	V min	DV _{DD} = 5 V
V_{INL} , Input Low Voltage	0.4	V max	DV _{DD} = 3 V
V_{INH} , Input High Voltage	2.5	V min	DV _{DD} = 3 V
Input Currents	±10	µA max	Logic Input = DV _{DD}
	-70	µA max	Logic Input = DGND, Typical -40 µA @ 5 V and -20 µA at 3 V
Input Capacitance	10	pF typ	All Digital Inputs
LOGIC OUTPUTS (Excluding XTAL2)⁵			
V_{OH} , Output High Voltage ²	DV _{DD} - 0.6	V min	DV _{DD} = 3 V, I _{SOURCE} = 100 µA
V_{OL} , Output Low Voltage ²	0.4	V max	DV _{DD} = 3 V, I _{SINK} = 100 µA
V_{OH} , Output High Voltage ²	4	V min	DV _{DD} = 5 V, I _{SOURCE} = 200 µA
V_{OL} , Output Low Voltage ²	0.4	V max	DV _{DD} = 5 V, I _{SINK} = 1.6 mA
Floating State Leakage Current	±10	µA max	
Floating State Output Capacitance	±10	pF typ	
Data Output Coding	Binary		Unipolar Mode
	Offset Binary		Bipolar Mode
SYSTEM CALIBRATION²			
Full-Scale Calibration Limit	1.05 × FS	V max	
Zero-Scale Calibration Limit	-1.05 × FS	V min	
Input Span	0.8 × FS	V min	
	2.1 × FS	V max	
START-UP TIME			
From Power-On	300	ms typ	
From Power-Down Mode	1	ms typ	Oscillator Enabled
	300	ms typ	Oscillator Powered Down
POWER REQUIREMENTS			
Power Supply Voltages	AV _{DD} and DV _{DD} can be operated independently of each other.		
AV _{DD} -AGND	2.7/3.6	V min/max	AV _{DD} = 3 V nom
	4.75/5.25	V min/max	AV _{DD} = 5 V nom
DV _{DD} -DGND	2.7/3.6	V min/max	DV _{DD} = 3 V nom
	4.75/5.25	V min	DV _{DD} = 5 V nom
DI _{DD} (Normal Mode)	0.55	mA max	DV _{DD} = 3 V, 0.43 mA typ
	0.65	mA max	DV _{DD} = 5 V, 0.5 mA typ
AI _{DD} (Normal Mode)	1.1	mA max	AV _{DD} = 3 V or 5 V, 0.85 mA typ
DI _{DD} (Power-Down Mode)	10	µA max	DV _{DD} = 3 V, 32.768 kHz Osc. Running
	2	µA max	DV _{DD} = 3 V, Oscillator Powered Down
	30	µA max	DV _{DD} = 5 V, 32.768 kHz Osc. Running
	8	µA max	DV _{DD} = 5 V, Oscillator Powered Down
AI _{DD} (Power-Down Mode)	1	µA max	AV _{DD} = 3 V or 5 V
Power Supply Rejection (PSR)			Input Range = ±2.56 V, AIN = 1 V
Chop Disabled	70	dB min	95 dB typ
Chop Enabled	100	dB typ	

NOTES

¹Temperature range is -40°C to +85°C.²Not production tested, guaranteed by design and/or characterization data at release.³Following a self-calibration this error will be in the order of the noise for the programmed gain and update selected. A system calibration will completely remove this error.⁴Recalibration at any temperature will remove these errors.⁵I/O Port Logic Levels are with respect to AV_{DD} and AGND.

Specifications are subject to change without notice.

AD7708/AD7718

AD7708 SPECIFICATIONS¹

($V_{DD} = 2.7\text{ V to }3.6\text{ V or }4.75\text{ V to }5.25\text{ V}$, $DV_{DD} = 2.7\text{ V to }3.6\text{ V or }4.75\text{ V to }5.25\text{ V}$, $REFIN(+)=2.5\text{ V}$; $REFIN(-)=AGND$; $AGND=DGND=0\text{ V}$; $XTAL1/XTAL2=32.768\text{ kHz}$ Crystal Input Buffers Enabled. All specifications T_{MIN} to T_{MAX} unless otherwise noted.)

Parameter	B Grade	Unit	Test Conditions
AD7708 (CHOP DISABLED)			
Output Update Rate	16.06	Hz min	$\overline{CHOP} = 1$
No Missing Codes ²	1.365	kHz max	
Resolution	16	Bits min	
	13	Bits p-p	$\pm 20\text{ mV Range, SF Word} = 69$
	16	Bits p-p	$\pm 2.56\text{ V Range, SF Word} = 69$
Output Noise and Update Rates	See Tables in ADC Description		
Integral Nonlinearity	± 15	ppm of FSR max	2ppm Typical
Offset Error ³	± 0.65	LSB typ	Following a Self-Calibration
Offset Error Drift vs. Temp ⁴	± 200	nV/°C typ	
Full-Scale Error ³	± 0.75	LSB typ	
Gain Drift vs. Temp ⁴	± 0.5	ppm/°C typ	
Negative Full-Scale Error	± 0.003	% FSR typ	
ANALOG INPUTS			
Differential Input Full-Scale Voltage	$\pm 1.024 \times REFIN/GAIN$	V nom	REFIN Refers to Both REFIN1 and REFIN2. $REFIN = REFIN(+)-REFIN(-)$ GAIN = 1 to 128
Absolute AIN Voltage Limits	AGND + 100 mV	V min	AIN1–AIN10 and AINCOM with
	$AV_{DD} - 100\text{ mV}$	V max	NEGBUF = 1
Absolute AINCOM Voltage Limits	AGND – 30 mV	V min	NEGBUF = 0
	$AV_{DD} + 30\text{ mV}$	V max	
Analog Input Current			AIN1–AIN10 and AINCOM with
			NEGBUF = 1
DC Input Current ²	± 1	nA max	
DC Bias Current Drift	± 5	pA/°C typ	
AINCOM Input Current			NEGBUF = 0
DC Input Current ²	± 125	nA/V typ	$\pm 2.56\text{ V Range}$
DC Bias Current Drift	± 2	pA/V/°C typ	
Normal-Mode Rejection ²			
@ 50 Hz	100	dB min	50 Hz $\pm 1\text{ Hz}$, SF Word = 82
@ 60 Hz	100	dB min	60 Hz $\pm 1\text{ Hz}$, SF Word = 68
Common-Mode Rejection			
@ DC	90	dB min	100 dB typ, Analog Input = 1 V, Input Range = $\pm 2.56\text{ V}$
@ 50 Hz	100	dB typ	110 dB typ on $\pm 20\text{ mV Range}$
@ 60 Hz	100	dB typ	50 Hz $\pm 1\text{ Hz}$, SF Word = 82 60 Hz $\pm 1\text{ Hz}$, SF Word = 68
REFERENCE INPUTS (REFIN1 AND REFIN2)			
REFIN(+) to REFIN(-) Voltage	2.5	V nom	REFIN Refers to Both REFIN1 and REFIN2
REFIN(+) to REFIN(-) Range ²	1	V min	
	AV_{DD}	V max	
REFIN Common-Mode Range	AGND – 30 mV	V min	
	$AV_{DD} + 30\text{ mV}$	V max	
Reference DC Input Current	0.5	$\mu\text{A/V typ}$	
Reference DC Input Current Drift	± 0.1	nA/V/°C typ	
Normal-Mode Rejection ²			
@ 50 Hz	100	dB min	50 Hz $\pm 1\text{ Hz}$, SF Word = 82
@ 60 Hz	100	dB min	60 Hz $\pm 1\text{ Hz}$, SF Word = 68
Common-Mode Rejection			Input Range = $\pm 2.56\text{ V}$
@ DC	100	dB typ	Analog Input = 1 V. Input Range = $\pm 2.56\text{ V}$
@ 50 Hz	100	dB typ	
@ 60 Hz	100	dB typ	

Parameter	B Grade	Unit	Test Conditions
AD7708 (CHOP ENABLED)			
Output Update Rate	5.4 105	Hz min Hz max	$\overline{\text{CHOP}} = 1$ 0.732 ms Increments
No Missing Codes ² Resolution	16 13 16	Bits min Bits p-p Bits p-p	20 Hz Update Rate ± 20 mV Range, 20 Hz Update Rate ± 2.56 V Range, 20 Hz Update Rate
Output Noise and Update Rates	See Tables in ADC Description		
Integral Nonlinearity	± 15	ppm of FSR max	2 ppm Typical
Offset Error ³	± 3	μV typ	Calibration is Accurate to ± 0.5 LSB
Offset Error Drift vs. Temp ⁴	10	nV/ $^{\circ}\text{C}$ typ	
Full-Scale Error ³	± 0.75	LSB typ	
Gain Drift vs. Temp ⁴	± 0.5	ppm/ $^{\circ}\text{C}$ typ	Includes Positive and Negative ERRORS
ANALOG INPUTS			
Differential Input Full-Scale Voltage	$\pm 1.024 \times \text{REFIN}/\text{GAIN}$	V nom	REFIN Refers to Both REFIN1 and REFIN2. REFIN = REFIN(+) REFIN(-) GAIN = 1 to 128
Range Matching	± 2	μV typ	Analog Input = 18 mV
Absolute AIN Voltage Limits	AGND + 100 mV AV _{DD} - 100 mV	V min V max	AIN1-AIN10 and AINCOM with NEGBUF = 1
Absolute AINCOM Voltage Limits	AGND - 30 mV AV _{DD} + 30 mV	V min V max	NEGBUF = 0
Analog Input Current			AIN1-AIN10 and AINCOM with NEGBUF = 1
DC Input Current ²	± 1	nA max	
DC Input Current Drift	± 5	pA/ $^{\circ}\text{C}$ typ	
AINCOM Input Current			NEGBUF = 0
DC Input Current ²	± 125	nA/V typ	
DC Bias Current Drift	± 2	pA/V/ $^{\circ}\text{C}$ typ	
Normal-Mode Rejection ²			
@ 50 Hz	100	dB min	50 Hz ± 1 Hz, SF Word = 82
@ 60 Hz	94	dB min	60 Hz ± 1 Hz, SF Word = 68
Common-Mode Rejection			
@ DC	90	dB min	100 dB typ, Analog Input = 1 V, Input Range = ± 2.56 V
@ 50 Hz ²	100	dB min	110 dB typ on ± 20 mV Range
@ 60 Hz ²	100	dB min	50 Hz ± 1 Hz, 20 Hz Update Rate 60 Hz ± 1 Hz, 20 Hz Update Rate
REFERENCE INPUTS (REFIN1 AND REFIN2)			
REFIN(+) to REFIN(-) Voltage	2.5 V	nom	REFIN Refers to Both REFIN1 and REFIN2
REFIN(+) to REFIN(-) Range ²	1	V min	
REFIN Common-Mode Range	AV _{DD} AGND - 30 mV AV _{DD} + 30 mV	V max V min V max	
Reference DC Input Current ²	± 0.5	$\mu\text{A}/\text{V}$ typ	
Reference DC Input Current Drift	± 0.01	nA/V/ $^{\circ}\text{C}$ typ	
Normal-Mode Rejection ²			
@ 50 Hz	100	dB min	50 Hz ± 1 Hz, SF Word = 82
@ 60 Hz	100	dB min	60 Hz ± 1 Hz, SF Word = 68
Common-Mode Rejection			Input Range = ± 2.56 V
@ DC	110	dB typ	Analog Input = 1 V
@ 50 Hz	110	dB typ	50 Hz ± 1 Hz, 20 Hz Update Rate
@ 60 Hz	110	dB typ	60 Hz ± 1 Hz, 20 Hz Update Rate
LOGIC INPUTS⁵			
All Inputs Except SCLK and XTAL1 ²			
V _{INL} , Input Low Voltage	0.8	V max	DV _{DD} = 5 V
	0.4	V max	DV _{DD} = 3 V
V _{INH} , Input High Voltage	2.0	V min	DV _{DD} = 3 V or 5 V

AD7708—SPECIFICATIONS¹

Parameter	B Grade	Unit	Test Conditions
LOGIC INPUTS (Continued)			
SCLK Only (Schmitt-Triggered Input) ²			
V _{T(+)}	1.4/2	V min/V max	DV _{DD} = 5 V
V _{T(-)}	0.8/1.4	V min/V max	DV _{DD} = 5 V
V _{T(+)} -V _{T(-)}	0.3/0.85	V min/V max	DV _{DD} = 5 V
V _{T(+)}	0.95/2	V min/V max	DV _{DD} = 3 V
V _{T(-)}	0.4/1.1	V min/V max	DV _{DD} = 3 V
V _{T(+)} -V _{T(-)}	0.3/0.85	V min/V max	DV _{DD} = 3 V
XTAL1 Only²			
V _{INL} , Input Low Voltage	0.8	V max	DV _{DD} = 5 V
V _{INH} , Input High Voltage	3.5	V min	DV _{DD} = 5 V
V _{INL} , Input Low Voltage	0.4	V max	DV _{DD} = 3 V
V _{INH} , Input High Voltage	2.5	V min	DV _{DD} = 3 V
Input Currents	±10 -70	µA max µA max	Logic Input = DV _{DD} Logic Input = DGND, Typical -40 µA @ 5 V and -20 µA at 3 V
Input Capacitance	10	pF typ	All Digital Inputs
LOGIC OUTPUTS (Excluding XTAL2)⁵			
V _{OH} , Output High Voltage ²	DV _{DD} - 0.6	V min	DV _{DD} = 3 V, I _{SOURCE} = 100 µA
V _{OL} , Output Low Voltage ²	0.4	V max	DV _{DD} = 3 V, I _{SINK} = 100 µA
V _{OH} , Output High Voltage ²	4	V min	DV _{DD} = 5 V, I _{SOURCE} = 200 µA
V _{OL} , Output Low Voltage ²	0.4	V max	DV _{DD} = 5 V, I _{SINK} = 1.6 mA
Floating State Leakage Current	±10	µA max	
Floating State Output Capacitance	±10	pF typ	
Data Output Coding	Binary Offset Binary		Unipolar Mode Bipolar Mode
SYSTEM CALIBRATION²			
Full-Scale Calibration Limit	1.05 × FS	V max	
Zero-Scale Calibration Limit	-1.05 × FS	V min	
Input Span	0.8 × FS 2.1 × FS	V min V max	
START-UP TIME			
From Power-On	300	ms typ	
From Power-Down Mode	1 300	ms typ ms typ	Oscillator Powered Down
POWER REQUIREMENTS			
Power Supply Voltages	AV _{DD} and DV _{DD} can be operated independently of each other.		
AV _{DD} -AGND	2.7/3.6 4.75/5.25	V min/max V min/max	AV _{DD} = 3 V nom AV _{DD} = 5 V nom
DV _{DD} -DGND	2.7/3.6 4.75/5.25	V min/max V min	DV _{DD} = 3 V nom DV _{DD} = 5 V nom
DI _{DD} (Normal Mode)	0.55 0.65	mA max mA	DV _{DD} = 3 V, 0.43 mA typ DV _{DD} = 5 V, 0.5 mA typ
AI _{DD} (Normal Mode)	1.1	mA	AV _{DD} = 3 V or 5 V, 0.85 mA typ
DI _{DD} (Power-Down Mode)	10 2 30 8	µA max µA max µA max µA max	DV _{DD} = 3 V, 32.768 kHz Osc. Running DV _{DD} = 3 V, Oscillator Powered Down DV _{DD} = 5 V, 32.768 kHz Osc. Running DV _{DD} = 5 V, Oscillator Powered Down
AI _{DD} (Power-Down Mode)	1	µA max	AV _{DD} = 3 V or 5 V
Power Supply Rejection (PSR)	Input Range = ±2.56 V, AIN = 1 V		
Chop Disabled	70	dB min	95 dB typ
Chop Enabled	100	dB typ	

NOTES

¹Temperature range is -40°C to +85°C.

²Not production tested, guaranteed by design and/or characterization data at release.

³Following a self-calibration this error will be in the order of the noise for the programmed gain and update selected. A system calibration will completely remove this error.

⁴Recalibration at any temperature will remove these errors.

⁵I/O Port Logic Levels are with respect to AV_{DD} and AGND.

Specifications are subject to change without notice.

TIMING CHARACTERISTICS^{1, 2} (AV_{DD} = 2.7 V to 3.6 V or AV_{DD} = 5 V ± 5%; DV_{DD} = 2.7 V to 3.6 V or DV_{DD} = 5 V ± 5%; AGND = DGND = 0 V; XTAL = 32.768 kHz; Input Logic 0 = 0 V, Logic 1 = DV_{DD} unless otherwise noted.

Parameter	Limit at T _{MIN} , T _{MAX} (B Version)	Unit	Conditions/Comments
t ₁	32.768	kHz typ	Crystal Oscillator Frequency
t ₂	50	ns min	$\overline{\text{RESET}}$ Pulsewidth
Read Operation			
t ₃	0	ns min	$\overline{\text{RDY}}$ to $\overline{\text{CS}}$ Setup Time
t ₄	0	ns min	$\overline{\text{CS}}$ Falling Edge to SCLK Active Edge Setup Time ³
t ₅ ⁴	0	ns min	SCLK Active Edge to Data Valid Delay ³
	60	ns max	DV _{DD} = 4.5 V to 5.5 V
	80	ns max	DV _{DD} = 2.7 V to 3.6 V
t _{5A} ^{4, 5}	0	ns min	$\overline{\text{CS}}$ Falling Edge to Data Valid Delay ³
	60	ns max	DV _{DD} = 4.5 V to 5.5 V
	80	ns max	DV _{DD} = 2.7 V to 3.6 V
t ₆	100	ns min	SCLK High Pulsewidth
t ₇	100	ns min	SCLK Low Pulsewidth
t ₈	0	ns min	$\overline{\text{CS}}$ Rising Edge to SCLK Inactive Edge Hold Time ³
t ₉ ⁶	10	ns min	Bus Relinquish Time after SCLK Inactive Edge ³
	80	ns max	
t ₁₀	100	ns max	SCLK Active Edge to $\overline{\text{RDY}}$ High ^{3, 7}
Write Operation			
t ₁₁	0	ns min	$\overline{\text{CS}}$ Falling Edge to SCLK Active Edge Setup Time ³
t ₁₂	30	ns min	Data Valid to SCLK Edge Setup Time
t ₁₃	25	ns min	Data Valid to SCLK Edge Hold Time
t ₁₄	100	ns min	SCLK High Pulsewidth
t ₁₅	100	ns min	SCLK Low Pulsewidth
t ₁₆	0	ns min	$\overline{\text{CS}}$ Rising Edge to SCLK Edge Hold Time

NOTES

¹Sample tested during initial release to ensure compliance. All input signals are specified with tr = tf = 5 ns (10% to 90% of DV_{DD}) and timed from a voltage level of 1.6 V.

²See Figures 1 and 2.

³SCLK active edge is falling edge of SCLK.

⁴These numbers are measured with the load circuit of Figure 1 and defined as the time required for the output to cross the V_{OL} or V_{OH} limits.

⁵This specification only comes into play if CS goes low while SCLK is low. It is required primarily for interfacing to DSP machines.

⁶These numbers are derived from the measured time taken by the data output to change 0.5 V when loaded with the load circuit of Figure 1. The measured number is then extrapolated back to remove effects of charging or discharging the 50 pF capacitor. This means that the times quoted in the timing characteristics are the true bus relinquish times of the part and as such are independent of external bus loading capacitances.

⁷ $\overline{\text{RDY}}$ returns high after the first read from the device after an output update. The same data can be read again, if required, while $\overline{\text{RDY}}$ is high, although care should be taken that subsequent reads do not occur close to the next output update.

Specifications subject to change without notice.

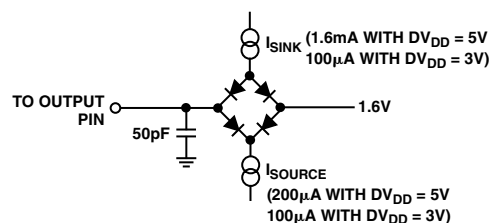

Figure 1. Load Circuit for Timing Characterization

AD7708/AD7718

ABSOLUTE MAXIMUM RATINGS*

(T_A = 25°C unless otherwise noted)

AV _{DD} to AGND	-0.3 V to +7 V
AV _{DD} to DGND	-0.3 V to +7 V
DV _{DD} to AGND	-0.3 V to +7 V
DV _{DD} to DGND	-0.3 V to +7 V
AGND to DGND	-0.05 V to +0.05 V
AV _{DD} to DV _{DD}	-5 V to +5 V
Analog Input Voltage to AGND	-0.3 V to AV _{DD} +0.3 V
Reference Input Voltage to AGND	..	-0.3 V to AV _{DD} +0.3 V
Total AIN/REFIN Current (Indefinite)	30 mA
Digital Input Voltage to DGND	-0.3 V to DV _{DD} +0.3 V
Digital Output Voltage to DGND	...	-0.3 V to DV _{DD} +0.3 V
Operating Temperature Range	-40°C to +85°C
Storage Temperature Range	-65°C to +150°C

Junction Temperature	150°C
SOIC Package		
θ _{JA} Thermal Impedance	71.4°C/W
θ _{JC} Thermal Impedance	23°C/W
TSSOP Package		
θ _{JA} Thermal Impedance	97.9°C/W
θ _{JC} Thermal Impedance	14°C/W
Lead Temperature, Soldering		
Vapor Phase (60 sec)	215°C
Infrared (15 sec)	220°C

*Stresses above those listed under Absolute Maximum Ratings may cause permanent damage to the device. This is a stress rating only; functional operation of the device at these or any other conditions above those listed in the operational sections of this specification is not implied. Exposure to absolute maximum rating conditions for extended periods may affect device reliability.

ORDERING GUIDE

Model	Temperature Range	Package Description	Package Option
AD7708BR	-40°C to +85°C	SOIC	R-28
AD7708BRU	-40°C to +85°C	TSSOP	RU-28
EVAL-AD7708EB			Evaluation Board
AD7718BR	-40°C to +85°C	SOIC	R-28
AD7718BRU	-40°C to +85°C	TSSOP	RU-28
EVAL-AD7718EB			Evaluation Board

CAUTION

ESD (electrostatic discharge) sensitive device. Electrostatic charges as high as 4000 V readily accumulate on the human body and test equipment and can discharge without detection. Although the AD7708/AD7718 features proprietary ESD protection circuitry, permanent damage may occur on devices subjected to high-energy electrostatic discharges. Therefore, proper ESD precautions are recommended to avoid performance degradation or loss of functionality.



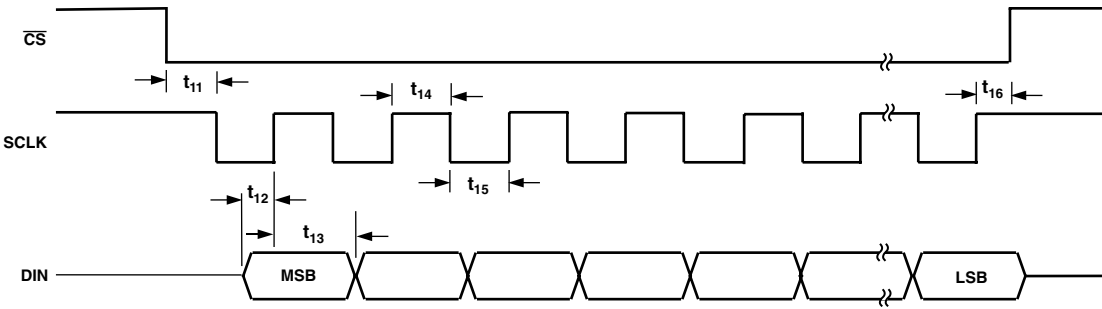

Figure 2. Write Cycle Timing Diagram

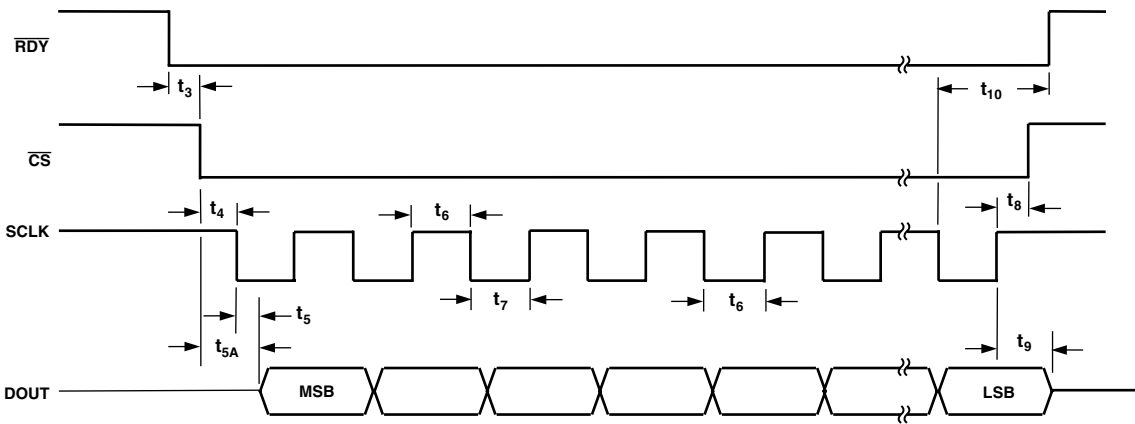

Figure 3. Read Cycle Timing Diagram

PIN FUNCTION DESCRIPTIONS

Pin No	Mnemonic	Function
1	AIN7	Analog Input Channel 7. Programmable-gain analog input that can be used as a pseudo-differential input when used with AINCOM, or as the positive input of a fully-differential input pair when used with AIN8. (See ADC Control Register section.)
2	AIN8	Analog Input Channel 8. Programmable-gain analog input that can be used as a pseudo-differential input when used with AINCOM, or as the negative input of a fully-differential input pair when used with AIN7. (See ADC Control Register section.)
3	AV _{DD}	Analog Supply Voltage
4	AGND	Analog Ground
5	REFIN1(-)	Negative Reference Input. This reference input can lie anywhere between AGND and AV _{DD} - 1 V.
6	REFIN1(+)	Positive reference input. REFIN(+) can lie anywhere between AV _{DD} and AGND. The nominal reference voltage [REFIN(+)-REFIN(-)] is 2.5 V but the part is functional with a reference range from 1 V to AV _{DD} .
7	AIN1	Analog Input Channel 1. Programmable-gain analog input that can be used as a pseudo-differential input when used with AINCOM, or as the positive input of a fully-differential input pair when used with AIN2. (See ADC Control Register Section.)
8	AIN2	Analog Input Channel 2. Programmable-gain analog input that can be used as a pseudo-differential input when used with AINCOM, or as the negative input of a fully-differential input pair when used with AIN1. (See ADC Control Register section.)
9	AIN3	Analog Input Channel 3. Programmable-gain analog input that can be used as a pseudo-differential input when used with AINCOM, or as the positive input of a fully-differential input pair when used with AIN4. (See ADC Control Register section.)
10	AIN4	Analog Input Channel 4. Programmable-gain analog input that can be used as a pseudo-differential input when used with AINCOM, or as the negative input of a fully-differential input pair when used with AIN3. (See ADC Control Register section.)
11	AIN5	Analog Input Channel 5. Programmable-gain analog input that can be used as a pseudo-differential input when used with AINCOM, or as the positive input of a fully-differential input pair when used with AIN6. (See ADC Control Register section ADCCON.)
12	AINCOM	All analog inputs are referenced to this input when configured in pseudo-differential input mode.
13	REFIN2(+)/AIN9	Positive reference input/analog input. This input can be configured as a reference input with the same characteristics as REFIN1(+) or as an additional analog input. When configured as an analog input this pin provides a programmable-gain analog input that can be used as a pseudo-differential input when used with AINCOM, or as the positive input of a fully-differential input pair when used with AIN10. (See ADC Control Register section.)
14	REFIN2(-)/AIN10	Negative reference input/analog input. This pin can be configured as a reference or analog input. When configured as a reference input it provides the negative reference input for REFIN2. When configured as an analog input it provides a programmable-gain analog input that can be used as a pseudo-differential input when used with AINCOM, or as the negative input of a fully-differential input pair when used with AIN9. (See ADC Control Register section.)
15	AIN6	Analog Input Channel 6. Programmable-gain analog input that can be used as a pseudo-differential input when used with AINCOM, or as the negative input of a fully-differential input pair when used with AIN5. (See ADC Control Register section.)
16	P2	P2 can act as a general-purpose Input/Output bit referenced between AV _{DD} and AGND. There is a weak pull-up to AV _{DD} internally on this pin.
17	AGND	It is recommended that this pin be tied directly to AGND.
18	P1	P1 can act as a general-purpose Input/Output bit referenced between AV _{DD} and AGND. There is a weak pull-up to AV _{DD} internally on this pin.
19	$\overline{\text{RESET}}$	Digital input used to reset the ADC to its power-on-reset status. This pin has a weak pull-up internally to DV _{DD} .
20	SCLK	Serial clock input for data transfers to and from the ADC. The SCLK has a Schmitt-trigger input making an opto-isolated interface more robust. The serial clock can be continuous with all data transmitted in a continuous train of pulses. Alternatively, it can be a noncontinuous clock with the information being transmitted to or from the AD7708/AD7718 in smaller batches of data.

Pin No	Mnemonic	Function
21	\overline{CS}	Chip Select Input. This is an active low logic input used to select the AD7708/AD7718. \overline{CS} can be used to select the AD7708/AD7718 in systems with more than one device on the serial bus or as a frame synchronization signal in communicating with the device. \overline{CS} can be hardwired low, allowing the AD7708/AD7718 to be operated in 3-wire mode with SCLK, DIN, and DOUT used to interface with the device.
22	\overline{RDY}	\overline{RDY} is a logic low status output from the AD7708/AD7718. \overline{RDY} is low when valid data exists in the data register for the selected channel. This output returns high on completion of a read operation from the data register. If data is not read, \overline{RDY} will return high prior to the next update indicating to the user that a read operation should not be initiated. The \overline{RDY} pin also returns low following the completion of a calibration cycle. \overline{RDY} does not return high after a calibration until the mode bits are written to enabling a new conversion or calibration.
23	DOUT	Serial data output with serial data being read from the output shift register of the ADC. The output shift register can contain data from any of the on-chip data, calibration or control registers.
24	DIN	Serial Data Input with serial data being written to the input shift register on the AD7708/AD7718. Data in this shift register is transferred to the calibration or control registers within the ADC depending on the selection bits of the Communications register.
25	DGND	Ground Reference Point for the Digital Circuitry.
26	DV _{DD}	Digital Supply Voltage, 3 V or 5 V Nominal.
27	XTAL2	Output from the 32 kHz Crystal Oscillator or Resonator Inverter.
28	XTAL1	Input to the 32 kHz Crystal Oscillator or Resonator Inverter.

PIN CONFIGURATION

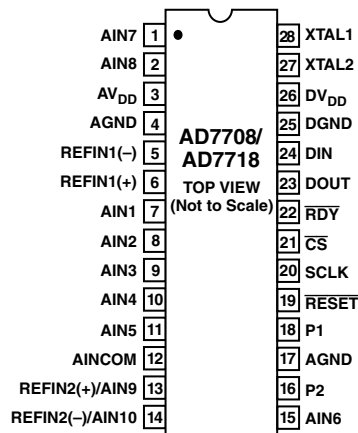

AD7708/AD7718—Typical Performance Characteristics

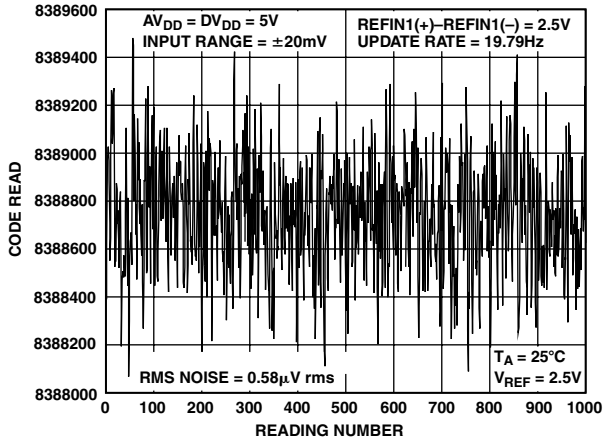

TPC 1. AD7718 Typical Noise Plot on ± 20 mV Input Range with 19.79 Hz Update Rate

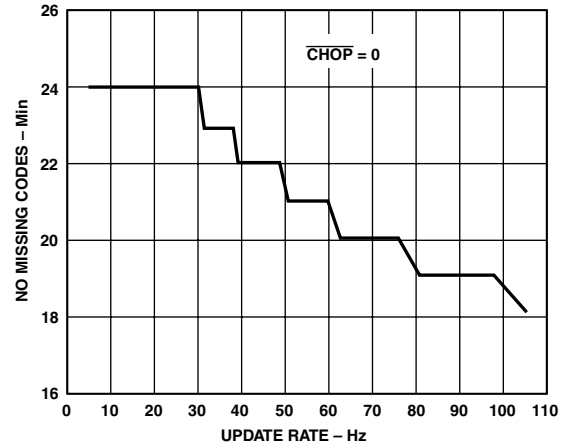

TPC 4. AD7718 No-Missing Codes Performance

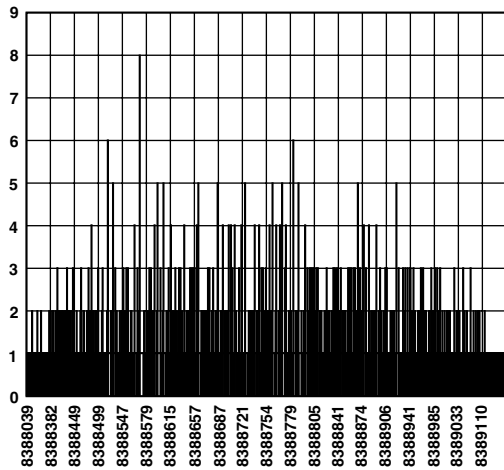

TPC 2. AD7718 Noise Distribution Histogram

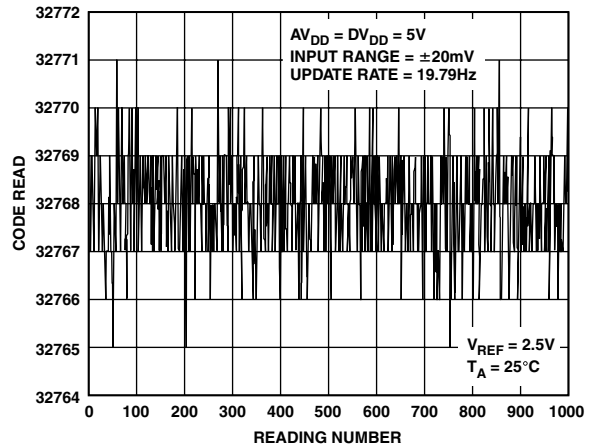

TPC 5. AD7708 Typical Noise Plot on ± 20 mV Input Range

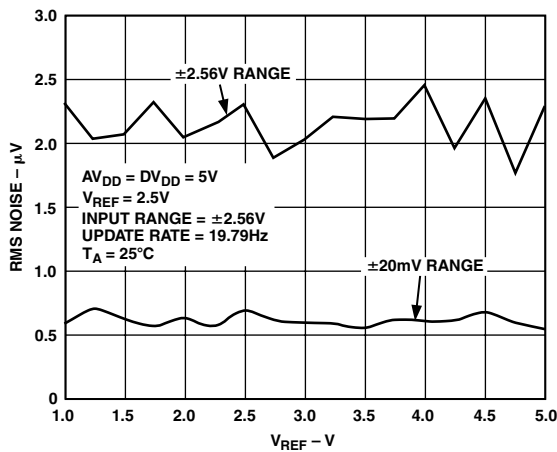

TPC 3. RMS Noise vs. Reference Input (AD7718 and AD7708)

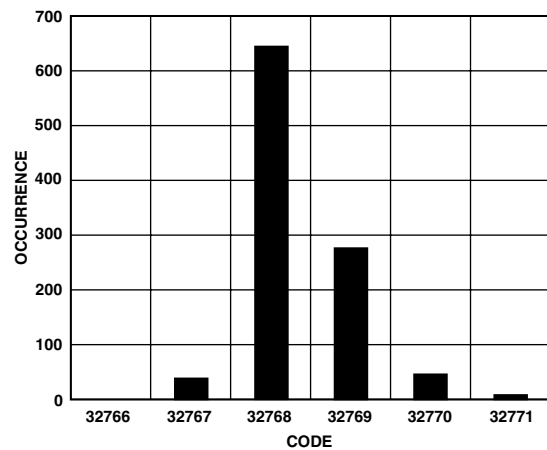

TPC 6. AD7708 Noise Histogram

ADC CIRCUIT INFORMATION

The AD7708/AD7718 incorporates a 10-channel multiplexer with a sigma-delta ADC, on-chip programmable gain amplifier and digital filtering intended for the measurement of wide dynamic range, low frequency signals such as those in weigh-scale, strain-gauge, pressure transducer, or temperature measurement applications. The AD7708 offers 16-bit resolution while the AD7718 offers 24-bit resolution. The AD7718 is a pin-for-pin compatible version of the AD7708. The AD7718 offers a direct upgradable path from a 16-bit to a 24-bit system without requiring any hardware changes and only minimal software changes.

These parts can be configured as four/five fully-differential input channels or as eight/ten pseudo-differential input channels referenced to AINCOM. The channel is buffered and can be programmed for one of eight input ranges from ± 20 mV to ± 2.56 V. Buffering the input channel means that the part can handle significant source impedances on the analog input and that R, C filtering (for noise rejection or RFI reduction) can be placed on the analog inputs if required. These input channels are intended to convert signals directly from sensors without the need for external signal conditioning.

The ADC employs a sigma-delta conversion technique to realize up to 24 bits of no missing codes performance. The sigma-delta modulator converts the sampled input signal into a digital pulse train whose duty cycle contains the digital information. A Sinc³ programmable low-pass filter is then employed to decimate the modulator output data stream to give a valid data conversion result at programmable output rates. The signal chain has two modes of operation, CHOP enabled and CHOP disabled. The $\overline{\text{CHOP}}$ bit in the mode register enables and disables the chopping scheme.

Signal Chain Overview (CHOP Enabled, CHOP = 0)

With CHOP = 0, chopping is enabled, this is the default and gives optimum performance in terms of drift performance. With chopping enabled, the available output rates vary from 5.35 Hz (186.77 ms) to 105.03 Hz (9.52 ms). A block diagram of the ADC input channel with chop enabled is shown in Figure 4.

The sampling frequency of the modulator loop is many times higher than the bandwidth of the input signal. The integrator in the modulator shapes the quantization noise (which results from the analog-to-digital conversion) so that the noise is pushed toward one-half of the modulator frequency. The output of the sigma-delta modulator feeds directly into the digital filter. The digital filter then band-limits the response to a frequency significantly lower than one-half of the modulator frequency. In this manner, the 1-bit output of the comparator is translated into a band limited, low noise output from the AD7708/AD7718 ADC. The AD7708/AD7718 filter is a low-pass, Sinc³ or $(\sin x/x)^3$

filter whose primary function is to remove the quantization noise introduced at the modulator. The cutoff frequency and decimated output data rate of the filter are programmable via the SF word loaded to the filter register. The complete signal chain is chopped resulting in excellent dc offset and offset drift specifications and is extremely beneficial in applications where drift, noise rejection, and optimum EMI rejection are important factors. With chopping, the ADC repeatedly reverses its inputs. The decimated digital output words from the Sinc³ filters, therefore, have a positive offset and negative offset term included. As a result, a final summing stage is included so that each output word from the filter is summed and averaged with the previous filter output to produce a new valid output result to be written to the ADC data register. The programming of the Sinc³ decimation factor is restricted to an 8-bit register SF, the actual decimation factor is the register value times 8. The decimated output rate from the Sinc³ filter (and the ADC conversion rate) will therefore be

$$f_{ADC} = \frac{1}{3} \times \frac{1}{8 \times SF} \times f_{MOD}$$

where

f_{ADC} in the ADC conversion rate.

SF is the decimal equivalent of the word loaded to the filter register.

f_{MOD} is the modulator sampling rate of 32.768 kHz.

The chop rate of the channel is half the output data rate:

$$f_{CHOP} = \frac{1}{2 \times f_{ADC}}$$

As shown in the block diagram, the Sinc³ filter outputs alternately contain $+V_{OS}$ and $-V_{OS}$, where V_{OS} is the respective channel offset. This offset is removed by performing a running average of two. This average by two means that the settling time to any change in programming of the ADC will be twice the normal conversion time, while an asynchronous step change on the analog input will not be fully reflected until the third subsequent output.

$$t_{SETTLE} = \frac{2}{f_{ADC}} = 2 \times t_{ADC}$$

The allowable range for SF is 13 to 255 with a default of 69 (45H). The corresponding conversion rates, conversion times, and settling times are shown in Table I. Note that the conversion time increases by 0.732 ms for each increment in SF.

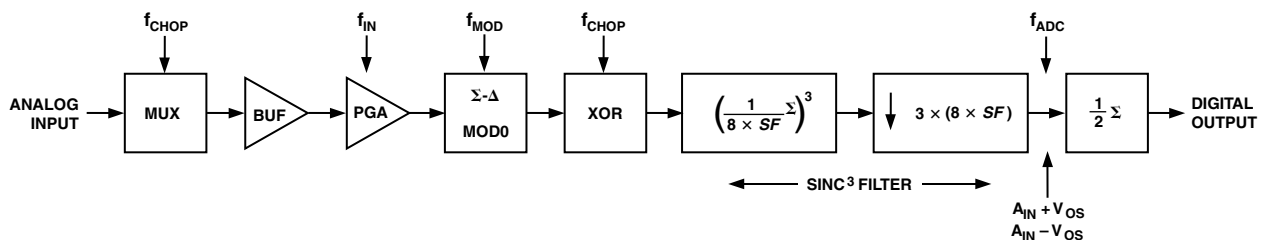

Figure 4. ADC Channel Block Diagram with CHOP Enabled

AD7708/AD7718

Table I. ADC Conversion and Settling Times for Various SF Words with CHOP = 0

SF Word	Data Update Rate f_{ADC} (Hz)	Settling Time t_{SETTLE} (ms)
13	105.3	19.04
23	59.36	33.69
27	50.56	39.55
45	30.3	65.9
69 (Default)	19.79	101.07
91	15	133.1
182	7.5	266.6
255	5.35	373.54

The overall frequency response is the product of a sinc^3 and a sinc response. There are sinc^3 notches at integer multiples of $3 \times f_{ADC}$ and there are sinc notches at odd integer multiples of $f_{ADC}/2$. The 3 dB frequency for all values of SF obeys the following equation:

$$f(3 \text{ dB}) = 0.24 \times f_{ADC}$$

Normal-mode rejection is the major function of the digital filter on the AD7708/AD7718. The normal mode 50 ± 1 Hz rejection with an SF word of 82 is typically -100 dB. The 60 ± 1 Hz rejection with SF = 68 is typically -100 dB. Simultaneous 50 Hz and 60 Hz rejection of better than 60 dB is achieved with an SF of 69. Choosing an SF word of 69 places notches at both 50 Hz and 60 Hz. Figures 5 to 9 show the filter rejection for a selection of SF words.

The frequency response of the filter $H(f)$ is as follows:

$$\left(\frac{1}{SF \times 8} \times \frac{\sin(SF \times 8 \times \pi \times f / f_{MOD})}{\sin(\pi \times f / f_{MOD})} \right)^3 \times \left(\frac{1}{2} \times \frac{\sin(2 \times \pi \times f / f_{OUT})}{\sin(\pi \times f / f_{OUT})} \right)$$

where

$$f_{MOD} = 32,768 \text{ Hz,}$$

SF = value programmed into SF Register,

$$f_{OUT} = f_{MOD} / (SF \times 8 \times 3).$$

The following plots show the filter frequency response for a variety of update rates from 5 Hz to 105 Hz.

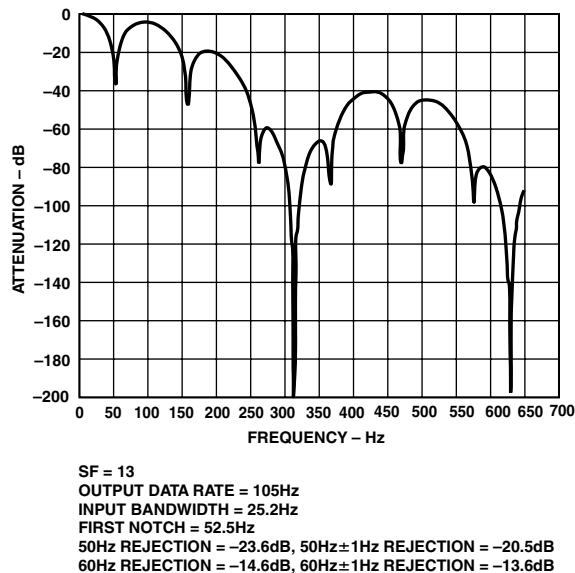

Figure 5. Filter Profile with SF = 13

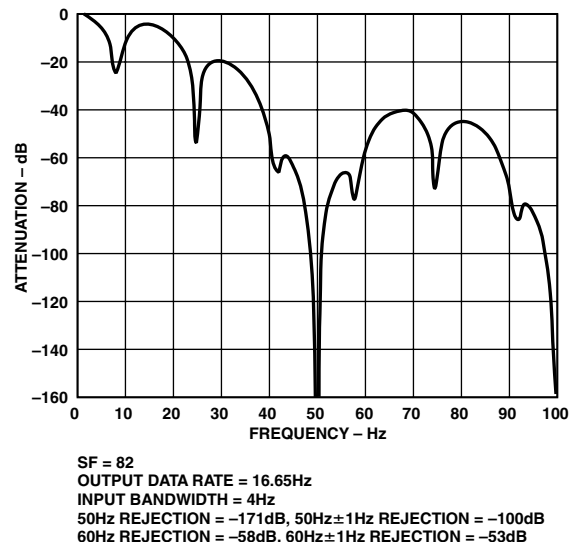
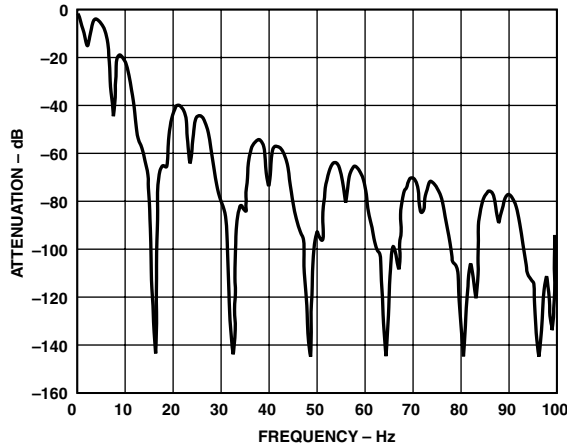
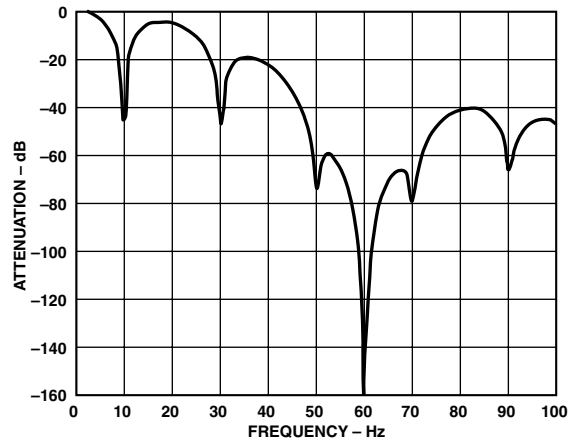

Figure 6. Filter Profile with SF = 82



SF = 255
 OUTPUT DATA RATE = 5.35Hz
 INPUT BANDWIDTH = 1.28Hz
 50Hz REJECTION = -93dB, 50Hz±1Hz REJECTION = -93dB
 60Hz REJECTION = -74dB, 60Hz±1Hz REJECTION = -68dB

Figure 7. Filter Profile with SF = 255



SF = 68
 OUTPUT DATA RATE = 20.07Hz
 INPUT BANDWIDTH = 4.82Hz
 50Hz REJECTION = -74dB, 50Hz±1Hz REJECTION = -54.6dB
 60Hz REJECTION = -147dB, 60Hz±1Hz REJECTION = -101dB

Figure 9. Filter Profile with SF = 68

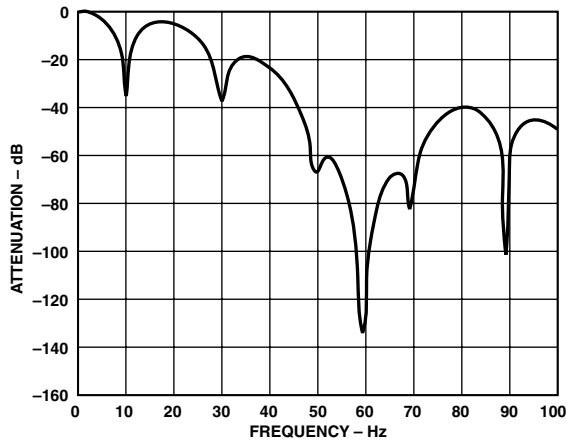

SF = 69
 OUTPUT DATA RATE = 19.8Hz
 INPUT BANDWIDTH = 4.74Hz
 FIRST NOTCH = 9.9Hz
 50Hz REJECTION = -66dB, 50Hz±1Hz REJECTION = -60dB
 60Hz REJECTION = -117dB, 60Hz±1Hz REJECTION = -94dB

Figure 8. Filter Profile with Default SF = 69 Giving Filter Notches at Both 50 Hz and 60 Hz

**ADC NOISE PERFORMANCE CHOP ENABLED
 (CHOP = 0)**

Tables II to V show the output rms noise and output peak-to-peak resolution in bits (rounded to the nearest 0.5 LSB) for a selection of output update rates. The numbers are typical and generated at a differential input voltage of 0 V with $AV_{DD} = DV_{DD} = 5$ V and using a 2.5 V reference. The output update rate is selected via the SF7–SF0 bits in the Filter Register. It is important to note that the peak-to-peak resolution figures represent the resolution for which there will be no code flicker within a six-sigma limit. The output noise comes from two sources. The first is the electrical noise in the semiconductor devices (device noise) used in the implementation of the modulator. Secondly, when the analog input is converted into the digital domain, quantization noise is added. The device noise is at a low level and is independent of frequency. The quantization noise starts at an even lower level but rises rapidly with increasing frequency to become the dominant noise source. The numbers in the tables are given for the bipolar input ranges. For the unipolar ranges the rms noise numbers will be the same as the bipolar range, but the peak-to-peak resolution is now based on half the signal range which effectively means losing one bit of resolution.

AD7708/AD7718

Table II. Typical Output RMS Noise vs. Input Range and Update Rate for AD7718 with Chop Enabled ($\overline{\text{CHOP}} = 0$); Output RMS Noise in μV

SF Word	Data Update Rate (Hz)	Input Range							
		$\pm 20 \text{ mV}$	$\pm 40 \text{ mV}$	$\pm 80 \text{ mV}$	$\pm 160 \text{ mV}$	$\pm 320 \text{ mV}$	$\pm 640 \text{ mV}$	$\pm 1.28 \text{ V}$	$\pm 2.56 \text{ V}$
13	105.3	1.50	1.50	1.60	1.75	3.50	4.50	6.70	11.75
23	59.36	1.0	1.02	1.06	1.15	1.22	1.77	3.0	5.08
27	50.56	0.95	0.95	0.98	1.00	1.10	1.66		5.0
69	19.79	0.60	0.65	0.65	0.65	0.65	0.95	1.40	2.30
255	5.35	0.35	0.35	0.37	0.37	0.37	0.51	0.82	1.25

Table III. Peak-to-Peak Resolution vs. Input Range and Update Rate for AD7718 with Chop Enabled ($\overline{\text{CHOP}} = 0$); Peak-to-Peak Resolution in Bits

SF Word	Data Update Rate (Hz)	Input Range							
		$\pm 20 \text{ mV}$	$\pm 40 \text{ mV}$	$\pm 80 \text{ mV}$	$\pm 160 \text{ mV}$	$\pm 320 \text{ mV}$	$\pm 640 \text{ mV}$	$\pm 1.28 \text{ V}$	$\pm 2.56 \text{ V}$
13	105.3	12	13	14	15	15	15.5	16	16
23	59.36	12.5	13.5	14.5	15	16	17	17	17
27	50.56	12.5	13.5	14.5	15.5	16.5	17	17	17
69	19.79	13	14	15	16	17	17.5	18	18.5
255	5.35	14	15	16	17	18	18.5	18.8	19.2

Table IV. Typical Output RMS Noise vs. Input Range and Update Rate for AD7708 with Chop Enabled ($\overline{\text{CHOP}} = 0$); Output RMS Noise in μV

SF Word	Data Update Rate (Hz)	Input Range							
		$\pm 20 \text{ mV}$	$\pm 40 \text{ mV}$	$\pm 80 \text{ mV}$	$\pm 160 \text{ mV}$	$\pm 320 \text{ mV}$	$\pm 640 \text{ mV}$	$\pm 1.28 \text{ V}$	$\pm 2.56 \text{ V}$
13	105.3	1.50	1.50	1.60	1.75	3.50	4.50	6.70	11.75
23	59.36	1.0	1.02	1.06	1.15	1.22	1.77	3.0	5.08
27	50.56	0.95	0.95	0.98	1.00	1.10	1.66		5.0
69	19.79	0.60	0.65	0.65	0.65	0.65	0.95	1.40	2.30
255	5.35	0.35	0.35	0.37	0.37	0.37	0.51	0.82	1.25

Table V. Peak-to-Peak Resolution vs. Input Range and Update Rate for AD7708 with Chop Enabled ($\overline{\text{CHOP}} = 0$); Peak-to-Peak Resolution in Bits

SF Word	Data Update Rate (Hz)	Input Range							
		$\pm 20 \text{ mV}$	$\pm 40 \text{ mV}$	$\pm 80 \text{ mV}$	$\pm 160 \text{ mV}$	$\pm 320 \text{ mV}$	$\pm 640 \text{ mV}$	$\pm 1.28 \text{ V}$	$\pm 2.56 \text{ V}$
13	105.3	12	13	14	15	15	15.5	16	16
23	59.35	12.5	13.5	14.5	15	16	16	16	16
27	50.56	12.5	13.5	14.5	15.5	16	16	16	16
69	19.79	13	14	15	16	16	16	16	16
255	5.35	14	15	16	16	16	16	16	16

SIGNAL CHAIN OVERVIEW CHOP DISABLED (CHOP = 1)

With $\overline{\text{CHOP}} = 1$ chopping is disabled. With chopping disabled the available output rates vary from 16.06 Hz (62.26 ms) to 1365.33 Hz (0.73 ms). The range of applicable SF words is from 3 to 255. When switching between channels with chop disabled, the channel throughput is increased by a factor of two over the case where chop is enabled. When used in multiplexed applications operation with chop disabled will offer the best throughput time when cycling through all channels. The drawback with chop disabled is that the drift performance is degraded and calibration is required following a gain change or significant temperature change. A block diagram of the ADC input channel with chop disabled is shown in Figure 10. The signal chain includes a mux, buffer, PGA, sigma-delta modulator, and digital filter. The modulator bit stream is applied to a Sinc³ filter. The programming of the Sinc³ decimation factor is restricted to an 8-bit register SF, the actual decimation factor is the register value times 8. The decimated output rate from the Sinc³ filter (and the ADC conversion rate) will therefore be:

$$f_{ADC} = \frac{f_{MOD}}{8 \times SF}$$

where

f_{ADC} is the ADC conversion rate,
 SF is the decimal equivalent of the word loaded to the filter register, valid range is from 3 to 255,
 f_{MOD} is the modulator sampling rate of 32.768 kHz.

The settling time to a step input is governed by the digital filter. A synchronized step change will require a settling time of three times the programmed update rate, a channel change can be treated as a synchronized step change. An unsynchronized step change will require four outputs to reflect the new analog input at its output.

$$t_{SETTLE} = \frac{3}{f_{ADC}} = 3 \times t_{ADC}$$

The allowable range for SF is 3 to 255 with a default of 69 (45H). The corresponding conversion rates, conversion times, and settling times are shown in Table VI. Note that the conversion time increases by 0.245 ms for each increment in SF.

Table VI. ADC Conversion and Settling Times for Various SF Words with CHOP = 1

SF Word	Data Update Rate f_{ADC} (Hz)	Settling Time t_{SETTLE} (ms)
03	1365.33	2.20
68	60.2	49.8
69 (Default)	59.36	50.54
75	54.6	54.93
82	49.95	60
151	27.13	110.6
255	16.06	186.76

The frequency response of the digital filter $H(f)$ is as follows:

$$\left(\frac{1}{SF \times 8} \times \frac{\sin(SF \times 8 \times \pi \times f/f_{MOD})}{\sin(\pi \times f/f_{MOD})} \right)^3$$

where

$f_{MOD} = 32,768$ Hz,
 SF = value programmed into SF SFR.

The following shows plots of the filter frequency response using different SF words for output data rates of 16 Hz to 1.36 kHz.

There are sinc³ notches at integer multiples of the update rate. The 3 dB frequency for all values of SF obeys the following equation:

$$f(3 \text{ dB}) = 0.262 \times f_{ADC}$$

The following plots show frequency response of the AD7708/AD7718 digital filter for various filter words. The AD7708/AD7718 are targeted at multiplexed applications. One of the key requirements in these applications is to optimize the SF word to obtain the maximum filter rejection at 50 Hz and 60 Hz while minimizing the channel throughput rate. Figure 12 shows the AD7708/AD7718 optimized throughput while maximizing 50 Hz and 60 Hz rejection. This is achieved with an SF word of 75. In Figure 13, by using a higher SF word of 151, 50 Hz and 60 Hz rejection can be maximized at 60 dB with a channel throughput rate of 110 ms. An SF word of 255 gives maximum rejection at both 50 Hz and 60 Hz but the channel throughput rate is restricted to 186 ms as shown in Figure 14.

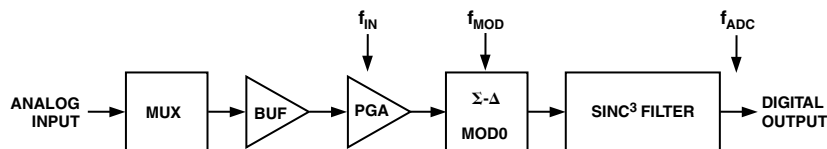
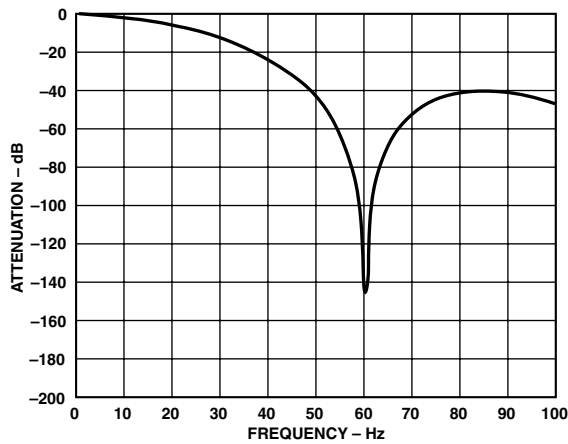

Figure 10. ADC Channel Block Diagram with CHOP Disabled

AD7708/AD7718



SF = 68
 OUTPUT DATA RATE = 60.2Hz
 SETTLING TIME = 49.8ms
 INPUT BANDWIDTH = 15.5Hz
 50Hz REJECTION = -43dB, 50Hz±1Hz REJECTION = -40dB
 60Hz REJECTION = -147dB, 60Hz±1Hz REJECTION = -101dB

Figure 11. Frequency Response Operating with the SF Word of 68

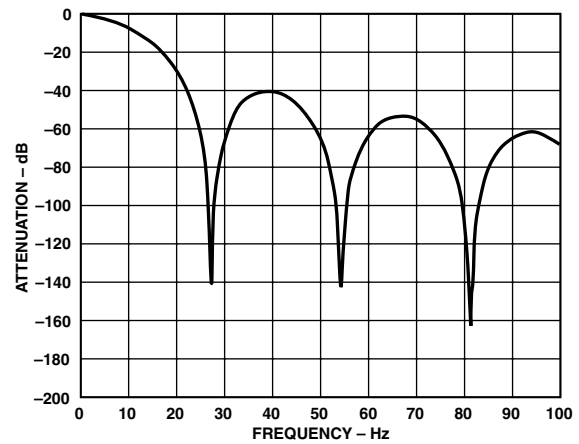

SF = 151
 OUTPUT DATA RATE = 27.12Hz
 SETTLING TIME = 110ms
 INPUT BANDWIDTH = 27.12Hz
 50Hz REJECTION = -65.4dB, 50Hz±1Hz REJECTION = -60dB
 60Hz REJECTION = -63dB, 60Hz±1Hz REJECTION = -60dB

Figure 13. Optimizing Filter Response for Maximum Simultaneous 50 Hz and 60 Hz Rejection

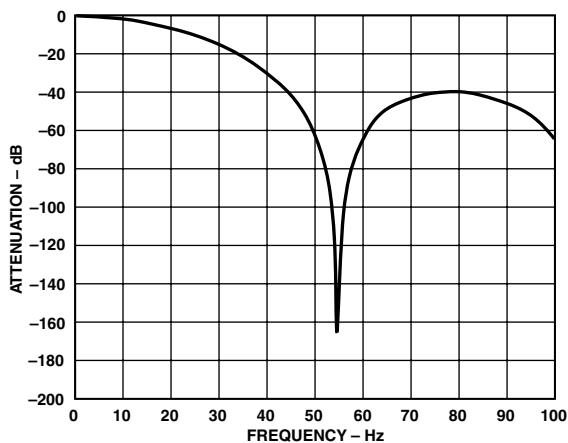

SF = 75
 OUTPUT DATA RATE = 54.6Hz
 SETTLING TIME = 55ms
 INPUT BANDWIDTH = 14.3Hz
 50Hz REJECTION = -62.5dB, 50Hz±1Hz REJECTION = -57dB
 60Hz REJECTION = -63dB, 60Hz±1Hz REJECTION = -60dB

Figure 12. Optimizing Filter Response for Throughput while Maximizing the Simultaneous 50 Hz and 60 Hz Rejection

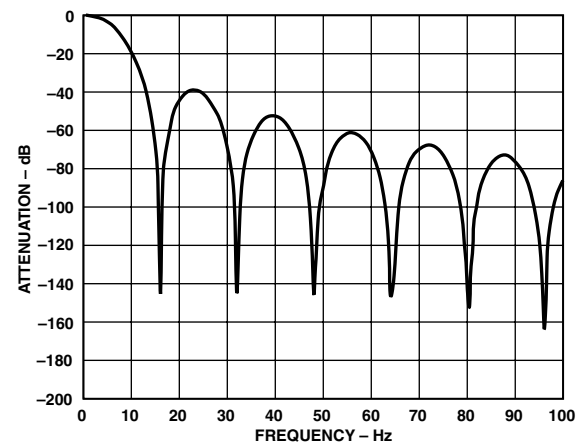

SF = 255
 OUTPUT DATA RATE = 16.06Hz
 SETTLING TIME = 186ms
 INPUT BANDWIDTH = 4.21Hz
 50Hz REJECTION = -87dB, 50Hz±1Hz REJECTION = -77dB
 60Hz REJECTION = -72dB, 60Hz±1Hz REJECTION = -68dB

Figure 14. Frequency with Maximum SF Word = 255

ADC NOISE PERFORMANCE CHOP DISABLED (CHOP = 1)

Tables VII to X show the output rms noise and output peak-to-peak resolution in bits (rounded to the nearest 0.5 LSB) for some typical output update rates. The numbers are typical and generated at a differential input voltage of 0 V. The output update rate is selected via the SF7-SF0 bits in the Filter Register. It is important to note that the peak-to-peak resolution figures represent the resolution for which there will be no code flicker within a six-sigma limit. The output noise comes from two sources. The first is the electrical noise in the semiconductor devices (device noise) used in the implementation of the modulator. Secondly,

when the analog input is converted into the digital domain, quantization noise is added. The device noise is at a low level and is independent of frequency. The quantization noise starts at an even lower level but rises rapidly with increasing frequency to become the dominant noise source. The numbers in the tables are given for the bipolar input ranges. For the unipolar ranges the rms noise numbers will be the same as the bipolar range, but the peak-to-peak resolution is now based on half the signal range which effectively means losing 1 bit of resolution.

Table VII. Typical Output RMS Noise vs. Input Range and Update Rate for AD7718 with Chop Disabled ($\overline{\text{CHOP}} = 1$); Output RMS Noise in μV

SF Word	Data Update Rate (Hz)	Input Range							
		$\pm 20 \text{ mV}$	$\pm 40 \text{ mV}$	$\pm 80 \text{ mV}$	$\pm 160 \text{ mV}$	$\pm 320 \text{ mV}$	$\pm 640 \text{ mV}$	$\pm 1.28 \text{ V}$	$\pm 2.56 \text{ V}$
03	1365.33	30.31	29.02	58.33	112.7	282.44	361.72	616.89	1660
13	315.08	2.47	2.49	2.37	3.87	7.18	12.61	16.65	32.45
66	62.06	0.743	0.852	0.9183	0.8788	0.8795	1.29	1.99	3.59
69	59.38	0.961	0.971	0.949	0.922	0.923	1.32	2.03	3.73
81	50.57	0.894	0.872	0.872	0.806	0.793	1.34	2.18	2.96
255	16.06	0.475	0.468	0.434	0.485	0.458	0.688	1.18	1.78

Table VIII. Peak-to-Peak Resolution vs. Input Range and Update Rate for AD7718 with Chop Disabled ($\overline{\text{CHOP}} = 1$); Peak-to-Peak Resolution in Bits

SF Word	Data Update Rate (Hz)	Input Range							
		$\pm 20 \text{ mV}$	$\pm 40 \text{ mV}$	$\pm 80 \text{ mV}$	$\pm 160 \text{ mV}$	$\pm 320 \text{ mV}$	$\pm 640 \text{ mV}$	$\pm 1.28 \text{ V}$	$\pm 2.56 \text{ V}$
03	1365.33	8	9	9	9	9	9	9	9
13	315.08	11	12	14	14	14	14	15	15
66	62.06	13	14	15	16	17	17	18	18
69	59.36	13	14	15	16	17	17	18	18
81	50.57	13	14	15	16	17	17	18	18
255	16.06	14	15	16	17	18	18	19	19

Table IX. Typical Output RMS Noise vs. Input Range and Update Rate for AD7708 with Chop Disabled ($\overline{\text{CHOP}} = 1$); Output RMS Noise in μV

SF Word	Data Update Rate (Hz)	Input Range							
		$\pm 20 \text{ mV}$	$\pm 40 \text{ mV}$	$\pm 80 \text{ mV}$	$\pm 160 \text{ mV}$	$\pm 320 \text{ mV}$	$\pm 640 \text{ mV}$	$\pm 1.28 \text{ V}$	$\pm 2.56 \text{ V}$
03	1365.33	30.31	29.02	58.33	112.7	282.44	361.72	616.89	1660
13	315.08	2.47	2.49	2.37	3.87	7.18	12.61	16.65	32.45
66	62.06	0.743	0.852	0.9183	0.8788	0.8795	1.29	1.99	3.59
69	59.38	0.961	0.971	0.949	0.922	0.923	1.32	2.03	3.73
81	50.57	0.894	0.872	0.872	0.806	0.793	1.34	2.18	2.96
255	16.06	0.475	0.468	0.434	0.485	0.458	0.688	1.18	1.78

Table X. Peak-to-Peak Resolution vs. Input Range and Update Rate for AD7708 with Chop Disabled ($\overline{\text{CHOP}} = 1$); Peak-to-Peak Resolution in Bits

SF Word	Data Update Rate (Hz)	Input Range							
		$\pm 20 \text{ mV}$	$\pm 40 \text{ mV}$	$\pm 80 \text{ mV}$	$\pm 160 \text{ mV}$	$\pm 320 \text{ mV}$	$\pm 640 \text{ mV}$	$\pm 1.28 \text{ V}$	$\pm 2.56 \text{ V}$
03	1365.33	8	9	9	9	9	9	9	9
13	315.08	11	12	14	14	14	14	15	15
66	62.06	13	14	15	16	16	16	16	16
69	59.36	13	14	15	16	16	16	16	16
81	50.57	13	14	15	16	16	16	16	16
255	16.06	14	15	16	16	16	16	16	16

AD7708/AD7718

ON-CHIP REGISTERS

The AD7708 and AD7718 are controlled and configured via a number of on-chip registers which are shown in Figure 15. The first of these registers is the communications register which is used to control all operations on these converters. All communications with these parts must start with a write to the communications register to specify the next operation to be performed. After a power-on or RESET, the device defaults to waiting for a write to the communications register. The STATUS register contains information pertaining to the operating conditions of the converter. The STATUS register is a read only register. The MODE register is used to configure the conversion mode, calibration, chop enable/disable, reference select, channel configuration and buffered or unbuffered operation on the AINCOM analog input. The MODE register is a read/write register. The ADC Control register is a read/write register used to select the active channel and program its input range and bipolar/unipolar operation. The I/O control register is a read/write register used to configure the operation of the 2-pin I/O

port. The filter register is a read/write register used to program the data update rate of the converter. The ADC Data register is a read only register that contains the result of a data conversion on the selected channel. The ADC offset registers are read/write registers that contain the offset calibration data. There are five offset registers, one for each of the fully differential input channels. When configured for pseudo-differential input mode the channels share offset registers. The ADC gain registers are read/write registers that contain the gain calibration data. There are five ADC gain registers, one for each of the fully differential input channels. When configured for pseudo differential input mode the channels share gain registers. The ADC contains Test registers for factory use only, the user is advised not to alter the operating conditions of these registers. The ID register is a read only register and is used for silicon identification purposes. The following sections contains more in-depth detail on all of these registers. In the following descriptions, *SET* implies a Logic 1 state and *CLEARED* implies a Logic 0 state unless otherwise stated.

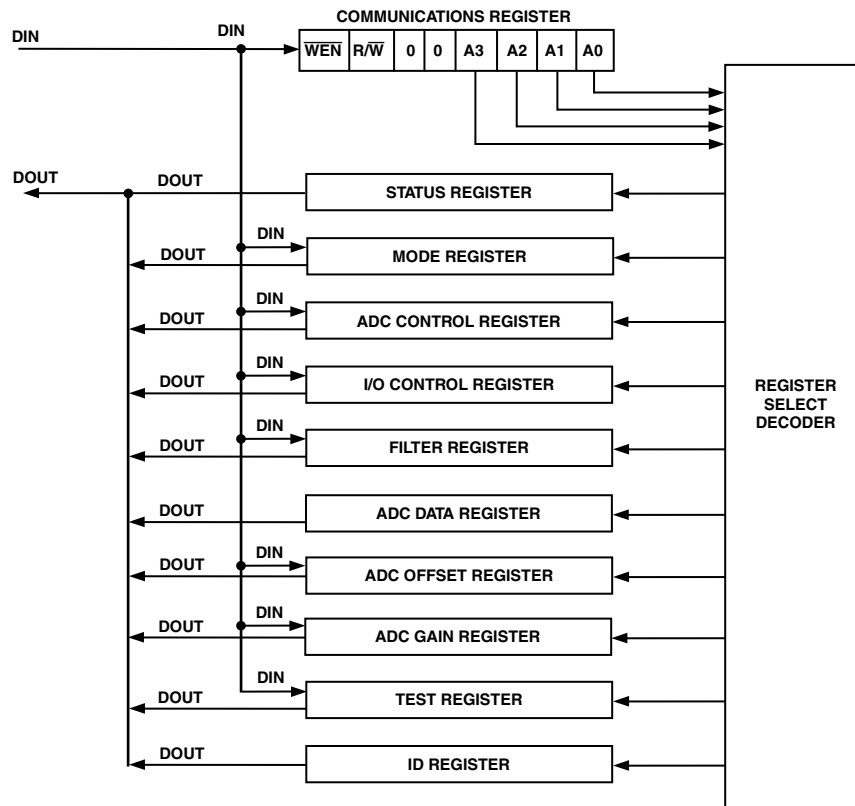

Figure 15. On-Chip Registers

AD7708/AD7718

Table XI. Registers—Quick Reference Guide (continued)

Power-On/Reset Register Name	Type	Size	Default Value	Function
AD7718 Offset Register	Read/Write	24 Bits	800 000 Hex	Contains a 24-bit word which is the offset calibration coefficient for the part. The contents of this register are used to provide offset correction on the output from the digital filter. There are five Offset Registers on the part and these are associated with input channels as outlined in the ADCCON register.
AD7718 Gain Register	Read/Write	24 Bits	5XXXXX5 Hex	Contains a 24-bit word which is the gain calibration coefficient for the part. The contents of this register are used to provide gain correction on the output from the digital filter. There are five Gain Registers on the part and these are associated with input channels as outlined in the ADCCON register.
AD7708 Offset Register	Read/Write	16 Bits	8000 Hex	Contains a 16-bit word which is the offset calibration coefficient for the part. The contents of this register are used to provide offset correction on the output from the digital filter. There are five Offset Registers on the part and these are associated with input channels as outlined in the ADCCON register.
AD7708 Gain Register	Read/Write	16 Bits	5XXX Hex	Contains a 16-bit word which is the gain calibration coefficient for the part. The contents of this register are used to provide gain correction on the output from the digital filter. There are five Gain Registers on the part and these are associated with input channels as outlined in the ADCCON register.
AD7708 ID Register	Read	8 Bits	5X Hex	Contains an 8-bit byte which is the identifier for the part.
AD7718 ID Register	Read	8 Bits	4X Hex	Contains an 8-bit byte which is the identifier for the part.
Test Registers	Read/Write	16 Bits	0000 Hex	Controls the test modes of the part that are used when testing the part. The user is advised not to change the contents of these registers.

Communications Register (A3, A2, A1, A0 = 0, 0, 0, 0)

The Communications Register is an 8-bit write-only register. All communications to the part must start with a write operation to the Communications Register. The data written to the Communications Register determines whether the next operation is a read or write operation, the type of read operation, and on which register this operation takes place. For read or write operations, once the subsequent read or write operation to the selected register is complete, the interface returns to where it expects a write operation to the Communications Register. This is the default state of the interface and, on power-up or after a $\overline{\text{RESET}}$, the AD7708/AD7718 is in this default state waiting for a write operation to the Communications Register. In situations where the interface sequence is lost, a write operation of at least 32 serial clock cycles with DIN high returns the AD7708/AD7718 to this default state by resetting the part. Table XII outlines the bit designations for the Communications Register. CR0 through CR7 indicate the bit location, CR denoting the bits are in the Communications Register. CR7 denotes the first bit of the data stream.

CR7	CR6	CR5	CR4	CR3	CR2	CR1	CR0
$\overline{\text{WEN}}$ (0)	R/ $\overline{\text{W}}$ (0)	0 (0)	0 (0)	A3 (0)	A2 (0)	A1 (0)	A0 (0)

Table XII. Communications Register Bit Designations

Bit Location	Bit Mnemonic	Description
CR7	$\overline{\text{WEN}}$	Write Enable Bit. A 0 must be written to this bit so the write operation to the Communications Register actually takes place. If a 1 is written to this bit, the part will not clock on to subsequent bits in the register. It will stay at this bit location until a 0 is written to this bit. Once a 0 is written to the $\overline{\text{WEN}}$ bit, the next seven bits will be loaded to the Communications Register.
CR6	R/ $\overline{\text{W}}$	A zero in this bit location indicates that the next operation will be a write to a specified register. A one in this position indicates that the next operation will be a read from the designated register.
CR5	0	A zero must be written to this bit position to ensure correct operation of the AD7708/AD7718.
CR4	0	A zero must be written to this bit position to ensure correct operation of the AD7708/AD7718.
CR3–CR0	A3–A0	Register Address Bits. These address bits are used to select which of the AD7708/AD7718's registers are being accessed during this serial interface communication. A3 is the MSB of the three selection bits.

Table XIII. Register Selection Table

A3	A2	A1	A0	Register
0	0	0	0	Communications Register during a Write Operation
0	0	0	0	Status Register during a Read Operation
0	0	0	1	Mode Register
0	0	1	0	ADC Control Register
0	0	1	1	Filter Register
0	1	0	0	ADC Data Register
0	1	0	1	ADC Offset Register
0	1	1	0	ADC Gain Register
0	1	1	1	I/O Control Register
1	0	0	0	Undefined
1	0	0	1	Undefined
1	0	1	0	Undefined
1	0	1	1	Undefined
1	1	0	0	Test 1 Register
1	1	0	1	Test 2 Register
1	1	1	0	Undefined
1	1	1	1	ID Register

AD7708/AD7718

Status Register (A3, A2, A1, A0 = 0, 0, 0, 0; Power-On-Reset = 00Hex)

The ADC Status Register is an 8-bit read-only register. To access the ADC Status Register, the user must write to the Communications Register selecting the next operation to be a read and load Bits A3-A0 with 0, 0, 0,0. Table XIV outlines the bit designations for the Status Register. SR0 through SR7 indicate the bit location, SR denoting the bits are in the Status Register. SR7 denotes the first bit of the data stream. The number in brackets indicates the power-on/reset default status of that bit.

SR7	SR6	SR5	SR4	SR3	SR2	SR1	SR0
RDY (0)	0 (0)	CAL (0)	0 (0)	ERR (0)	0 (0)	0 (0)	LOCK (0)

Table XIV. Status Register Bit Designations

Bit Location	Bit Mnemonic	Description
SR7	RDY	Ready Bit for the ADC <i>Set</i> when data is transferred to the ADC data registers or on completion of calibration cycle. The RDY bit is <i>cleared</i> automatically a period of time before the data register is updated with a new conversion result or after the ADC data register has been read. This bit is also cleared by a write to the mode bits to indicate a conversion or calibration. The $\overline{\text{RDY}}$ pin is the complement of the RDY bit.
SR6	0	Bit is automatically <i>cleared</i> . Reserved for future use
SR5	CAL	Calibration Status Bit <i>Set</i> to indicate completion of calibration. It is set at the same time that the RDY is set high. <i>Cleared</i> by a write to the mode bits to start another ADC conversion or calibration.
SR4	0	This bit is automatically <i>cleared</i> . Reserved for future use
SR3	ERR	ADC Error Bit <i>Set</i> to indicate that the result written to the ADC data register has been clamped to all zeros or all ones. After a calibration this bit also flags error conditions that caused the calibration registers not to be written. Error sources include Overrange. <i>Cleared</i> by a write to the mode bits to initiate a conversion or calibration.
SR2	0	This bit is automatically <i>cleared</i> . Reserved for future use
SR1	0	This bit is automatically <i>cleared</i> . Reserved for future use
SR0	LOCK	PLL Lock Status Bit. <i>Set</i> if the PLL has locked onto the 32.768 kHz crystal oscillator clock. If the user is worried about exact sampling frequencies etc., the LOCK bit should be interrogated and the result discarded if the LOCK bit is zero.

Mode Register (A3, A2, A1, A0 = 0, 0, 0, 1; Power-On-Reset = 00Hex)

The Mode Register is an 8-bit register from which data can be read or to which data can be written. This register configures the operating modes of the AD7708/AD7718. Table XV outlines the bit designations for the Mode Register. MR7 through MR0 indicate the bit location, MR denoting the bits are in the Mode Register. MR7 denotes the first bit of the data stream. The number in brackets indicates the power-on/reset default status of that bit.

MR7	MR6	MR5	MR4	MR3	MR2	MR1	MR0
$\overline{\text{CHOP}}$ (0)	NEGBUF (0)	REFSEL (0)	CHCON (0)	OSCPD (0)	MD2 (0)	MD1 (0)	MD0 (0)

Table XV. Mode Register Bit Designations

Bit Location	Bit Mnemonic	Description	
MR7	$\overline{\text{CHOP}}$	If this bit is <i>cleared</i> , chopping is enabled. When this bit is <i>set</i> chopping is disabled. The default is for chop enabled.	
MR6	NEGBUF	This bit controls the operation of the input buffer on the AINCOM input when a channel is configured for pseudo-differential mode of operation. If <i>cleared</i> , the analog negative input (AINCOM) is unbuffered allowing it to be tied to AGND in single-ended input configuration. If this bit is <i>set</i> the analog negative input (AINCOM) is buffered, placing a restriction on its common-mode input range.	
MR5	REFSEL	If this bit is <i>cleared</i> , the reference selected is REFIN1(+) and REFIN1(-) for the active channel. If this bit is <i>set</i> , the reference selected is REFIN2(+) and REFIN2(-) for the active channel. The contents of the CHCON bit overrides the REFSEL bit. If the ADC is configured in five fully-differential or 10 pseudo-differential input channel mode, the REFSEL bit setting is irrelevant as only one reference input is available. V_{REF} Select implemented using the REFSEL bit enables the user to perform both absolute and ratiometric measurements.	
MR4	CHCON	When <i>cleared</i> the device is configured as an 8-input channel converter, configured as eight pseudo-differential input channels with respect to AINCOM or four differential input arrangements with two reference input selection options. When <i>set</i> the device is configured as a 10 pseudo-differential input or a five differential input channel arrangement with a single reference input option.	
MR3	OSCPD	Oscillator Power-Down Bit. If this bit is <i>set</i> , placing the AD7708/AD7718 in standby mode will stop the crystal oscillator reducing the power drawn by these parts to a minimum. The oscillator will require 300 ms to begin oscillating when the ADC is taken out of standby mode. If this bit is <i>cleared</i> , the oscillator is not shut off when the ADC is put into standby mode and will not require the 300 ms start-up time when the ADC is taken out of standby.	
MR2–MR0	MD2–MD0	ADC Mode Bits. These bits select the operational mode of the ADC as follows:	
MD2	MD1	MD0	
0	0	0	Power-Down Mode (Power-On Default)
0	0	1	Idle Mode In Idle Mode the ADC filter and modulator are held in a reset state although the modulator clocks are still provided.
0	1	0	Single Conversion Mode In Single Conversion Mode, a single conversion is performed on the enabled channels. On completion of the conversion the ADC data registers are updated, the relevant flags in the STATUS register are written, and idle mode is reentered with the MD2–MD0 being written accordingly to 001.
0	1	1	Continuous Conversion In continuous conversion mode, the ADC data registers are regularly updated at the selected update rate (see Filter register).
1	0	0	Internal Zero-Scale Calibration Internal short automatically connected to the enabled channel(s)
1	0	1	Internal Full-Scale Calibration External V_{REF} is connected automatically to the ADC input for this calibration.
1	1	0	System Zero-Scale Calibration User should connect system zero-scale input to the channel input pins as selected by CH3–CH0 bits in the control registers.
1	1	1	System Full-Scale Calibration User should connect system full-scale input to the channel input pins as selected by CH3–CH0 bits in the control registers.

AD7708/AD7718

Operating Characteristics when Addressing the Mode and Control Registers

1. Any change to the MD bits will immediately reset the ADCs. A write to the MD2–MD0 bits with no change is also treated as a reset.
2. Once the MODE has been written with a calibration mode, the RDY bit (STATUS) is immediately reset and the calibration commences. On completion the appropriate calibration registers are written, the bit in STATUS register is updated and the MD2–MD0 bits are reset to 001 to indicate the ADC is back in idle mode.
3. Calibrations are performed with the maximum allowable SF value with chop enabled. SF register is reset to user configuration after calibration with chop enabled. Calibrations are performed with the selected value of SF when chop is disabled.

ADC Control Register (ADCCON): (A3, A2, A1, A0 = 0, 0, 1, 0; Power-On-Reset = 07 Hex)

The ADC Control Register is an 8-bit register from which data can be read or to which data can be written. This register is used to configure the ADC for range, channel selection, and unipolar or bipolar coding. Table XVI outlines the bit designations for the ADC control register ADCCON7 through ADCCON0 indicate the bit location, ADCCON denoting the bits are in the ADC Control Register. ADCCON7 denotes the first bit of the data stream. The number in brackets indicates the power-on/reset default status of that bit.

ADCCON7	ADCCON6	ADCCON5	ADCCON4	ADCCON3	ADCCON2	ADCCON1	ADCCON0
CH3 (0)	CH2 (0)	CH1 (0)	CH0 (0)	U/B̄ (0)	RN2 (1)	RN1 (1)	RN0 (1)

Table XVI. ADC Control Register (ADCCON) Bit Designations

Bit Location		Bit Mnemonic		Description						
ADCCON7		CH3		ADC Channel Selection Bits. Written by the user to select either pseudo-differential or fully-differential input pairs used by the ADC as follows:						
ADCCON6		CH2								
ADCCON5		CH1								
ADCCON4		CH0								
CH3	CH2	CH1	CH0	8-Channel Configuration (CHCON = 0)			10-Channel Configuration (CHCON = 1)		Cal Register Pair	
				Positive Input	Negative Input	Cal Register Pair	Positive Input	Negative Input		
0	0	0	0	AIN1	AINCOM	1	AIN1	AINCOM	1	
0	0	0	1	AIN2	AINCOM	2	AIN2	AINCOM	2	
0	0	1	0	AIN3	AINCOM	3	AIN3	AINCOM	3	
0	0	1	1	AIN4	AINCOM	4	AIN4	AINCOM	4	
0	1	0	0	AIN5	AINCOM	1	AIN5	AINCOM	5	
0	1	0	1	AIN6	AINCOM	2	AIN6	AINCOM	1	
0	1	1	0	AIN7	AINCOM	3	AIN7	AINCOM	2	
0	1	1	1	AIN8	AINCOM	4	AIN8	AINCOM	3	
1	0	0	0	AIN1	AIN2	1	AIN1	AIN2	1	
1	0	0	1	AIN3	AIN4	2	AIN3	AIN4	2	
1	0	1	0	AIN5	AIN6	3	AIN5	AIN6	3	
1	0	1	1	AIN7	AIN8	4	AIN7	AIN8	4	
1	1	0	0	AIN2	AIN2	1	AIN9	AIN10	5	
1	1	0	1	AINCOM	AINCOM	1	AINCOM	AINCOM	1	
1	1	1	0	REFIN(+)	REFIN(-)	1	AIN9	AINCOM	4	
1	1	1	1	OPEN	OPEN	1	AIN10	AINCOM	5	
ADCCON3		U/B̄		Unipolar/Bipolar Bit. Set by user to enable unipolar coding i.e., zero differential input will result in 00000hex output and a full-scale differential input will result in FFFFFFF Hex output when operated in 24-bit mode. Cleared by user to enable bipolar coding, Negative full-scale differential input will result in an output code of 000000 Hex, zero differential input will result in an output code of 800000 Hex and a positive full-scale differential input will result in an output code of FFFFFFF Hex.						

Table XVI. ADC Control Register (ADCCON) Bit Designations (continued)

AD0C2 AD0C1 AD0C0	RN2 RN1 RN0	ADC Range Bits			
		RN2	RN1	RN0	Selected ADC Input Range (VREF = 2.5 V)
		Written by the user to select the ADC input range as follows			
		0	0	0	±20 mV
		0	0	1	±40 mV
		0	1	0	±80 mV
		0	1	1	±160 mV
		1	0	0	±320 mV
		1	0	1	±640 mV
		1	1	0	±1.28 V
		1	1	1	±2.56 V

Filter Register (A3, A2, A1, A0 = 0, 0, 1, 1; Power-On Reset = 45Hex)

The Filter Register is an 8-bit register from which data can be read or to which data can be written. This register determines the amount of averaging performed by the sinc filter. Table XVII outlines the bit designations for the Filter Register. FR7 through FR0 indicate the bit location, FR denoting the bits are in the Filter Register. FR7 denotes the first bit of the data stream. The number in brackets indicates the power-on/reset default status of that bit. The number in this register is used to set the decimation factor and thus the output update rate for the ADCs. The filter register cannot be written to by the user the ADC is active. The update rate is used for the ADCs is calculated as follows:

$$f_{ADC} = \frac{1}{3} \times f_{MOD} \text{ CHOP Enabled } (\overline{CHOP} = 0)$$

$$f_{ADC} = \frac{1}{8 \times SF} \times f_{MOD} \text{ CHOP Disabled } (\overline{CHOP} = 1)$$

where

- f_{ADC} = ADC Output Update Rate,
- f_{MOD} = Modulator Clock Frequency = 32.768 kHz,
- SF = Decimal Value Written to SF Register.

Table XVII. Filter Register Bit Designations

FR7	FR6	FR5	FR4	FR3	FR2	FR1	FR0
SF7 (0)	SF6 (1)	SF5 (0)	SF4 (0)	SF3 (0)	SF2 (1)	SF1 (0)	SF0 (1)

The allowable range for SF is 13 decimal to 255 decimal with chop enabled, and the allowable SF range when chop is disabled is 03 decimal to 255 decimal. Examples of SF values and corresponding conversion rate (f_{ADC}) and time (t_{ADC}) are shown in Table XVIII. It should be noted that optimum performance is obtained when operating with chop enabled. When chopping is enabled ($\overline{CHOP} = 0$), the filter register is loaded with FF HEX during a calibration cycle. With chop disabled ($\overline{CHOP} = 1$), the value in the filter register is used during calibration.

Table XVIII. Update Rate vs. SF Word

SF (Dec)	SF (Hex)	CHOP Enabled		CHOP Disabled	
		f_{ADC} (Hz)	t_{ADC} (ms)	f_{ADC} (Hz)	t_{ADC} (ms)
03	03	N/A	N/A	1365.33	0.732
13	0D	105.3	9.52	315	3.17
69	45	19.79	50.34	59.36	16.85
255	FF	5.35	186.77	16.06	62.26

AD7708/AD7718

I/O Control Register (IOCON): (A3, A2, A1, A0 = 0, 1, 1, 1; Power-On-Reset = 00Hex)

The IOCON Register is an 8-bit register from which data can be read or to which data can be written. This register is used to control and configure the I/O port. Table XIX outlines the bit designations for this register. IOCON7 through IOCON0 indicate the bit location, IOCON denoting the bits are in the I/O Control Register. IOCON7 denotes the first bit of the data stream. The number in brackets indicates the power-on/reset default status of that bit. A write to the IOCON register has immediate effect and does not reset the ADCs.

IOCON7	IOCON6	IOCON5	IOCON4	IOCON3	IOCON2	IOCON1	IOCON0
(0)	0 (0)	P2DIR (0)	P1DIR (0)	0 (0)	0 (0)	P2DAT (0)	P1DAT (0)

Table XIX. IOCON (I/O Control Register) Bit Designations

Bit Location	Bit Mnemonic	Description
IOCON7	0	This bit should always be <i>cleared</i> . Reserved for future use.
IOCON6	0	This bit should always be <i>cleared</i> . Reserved for future use.
IOCON5	P2DIR	P2, I/O Direction Control Bit. Set by user to enable P2 as an output. Cleared by user to enable P2 as an input. There are weak pull-ups internally when enabled as an input.
IOCON4	P1DIR	P1, I/O Direction Control Bit. Set by user to enable P1 as an output. Cleared by user to enable P1 as an input. There are weak pull-ups internally when enabled as an input.
IOCON3	0	This bit should always be <i>cleared</i> . Reserved for future use.
IOCON2	0	This bit should always be <i>cleared</i> . Reserved for future use.
IOCON1	P2DAT	Digital I/O Port (P1) Data Bit. The readback value of this bit indicates the status of the pin regardless of whether this pin is configured as an input or an output. The value written to this data bit will appear at the output port when the I/O pin is enabled as an output.
IOCON0	P1DAT	Digital I/O port (P1) Data Bit. The readback value of this bit indicates the status of the pin, regardless of whether this pin is configured as an input or an output. The value written to this data bit will appear at the output port when the I/O pin is enabled as an output.

ADC Data Result Register (DATA): (A3, A2, A1, A0 = 0, 1, 0, 0; Power-On-Reset = 000000Hex)

The conversion result for the selected ADC channel is stored in the ADC data register (DATA). This register is 16 bits wide on the AD7708 and 24 bits wide on the AD7718. This is a read only register. On completion of a read from this register the RDY bit in the status register is cleared. These ADCs can be operated in either unipolar or bipolar mode of operation.

Unipolar Mode

In unipolar mode of operation the output coding is straight binary. With an analog input voltage of 0 V the output code is 0000Hex for the AD7708 and 000000Hex for the AD7718. With an analog input voltage of $1.024 V_{REF}/Gain$ the output code is FFFFHex for the AD7708 and FFFFFFF Hex for the AD7718. The output code for any analog input voltage can be represented as follows:

$$Code = (AIN \times GAIN \times 2^N) / (1.024 \times V_{REF})$$

where

AIN is the analog input voltage and

$N = 16$ for the AD7708 and $N = 24$ for the AD7718.

Bipolar Mode

With an analog input voltage of $(-1.024 V_{REF}/GAIN)$, the output code is 0000 Hex using the AD7708 and 000000H using the AD7718. With an analog input voltage of 0 V, the output code is 8000Hex for the AD7708 and 800000Hex for the AD7718. With an analog input voltage of $(+1.024 V_{REF}/GAIN)$, the output code is FFFF Hex for the AD7708 and FFFFFFF Hex for the AD7718. Note the analog inputs are pseudo bipolar inputs and the analog input voltage must remain within the common-mode input range at all times. The output code for any analog input voltage can be represented as follows:

$$Code = 2^{N-1} \times [(AIN \times GAIN/1.024 \times V_{REF}) + 1]$$

where

AIN is the analog input voltage,

$N = 16$ for the AD7708, and

$N = 24$ for the AD7718.

ADC Offset Calibration Coefficient Registers (OF0): (A3, A2, A1, A0 = 0, 1, 0, 1; Power-On-Reset = 8000(00)Hex)

The offset calibration registers are 16-bit registers on the AD7708 and 24-bit registers on the AD7718. These registers hold the offset calibration coefficient for the ADC. The power-on-reset value of the internal zero-scale calibration coefficient registers is 8000(00). There are five offset registers available, one for each of the fully differential input channels. Calibration register pairs are shared when operating in pseudo-differential input mode. However, these bytes will be automatically overwritten if an internal or system zero-scale calibration is initiated by the user via MD2–MD0 bits in the MODE register. The channel bits, in association with the communication register address for the OF0 register, allow access to this register. This register is a read/write register. The calibration register can only be written to if the ADC is inactive (MD bits in the mode register = 000 or 001). Reading of the calibration register does not clear the RDY bit.

ADC Gain Calibration Coefficient Register (GNO): (A3, A2, A1, A0 = 0, 1, 1, 0; Power-On-Reset = 5XXX(X5) Hex)

The gain calibration registers are 16-bit registers on the AD7708 and 24-bit registers on the AD7718. These registers are configured at power-on with factory-calculated internal full-scale calibration coefficients. There are five full-scale registers available, one for each of the fully differential input channels. Calibration register pairs are shared when operating in pseudo-differential input mode. Every device will have different default coefficients. However, these bytes will be automatically overwritten if an internal or system full-scale calibration is initiated by the user via MD2–MD0 bits in the MODE register. The channel bits, in association with the communication register address, allow access to the data contained in the GN0 register. This is a read/write register. The calibration registers can only be written to if the ADC is inactive (MD bits in the mode register = 000 or 001). Reading of the calibration registers does not clear the RDY bit. A calibration (self or system) is required when operating with chop mode disabled.

ID Register (ID): (A3, A2, A1, A0 = 1, 1, 1, 1; Power-On-Reset = 4X Hex (AD7718) and 5X Hex (AD7708))

This register is a read only 8-bit register. The contents are used to determine the die revision of the silicon. Table XX indicates the bit locations for the AD7708.

Table XX. ID Register Bit Designation

ID7	ID6	ID5	ID4	ID3	ID2	ID1	ID0
0	1	0	0/1	X	X	X	X

User Nonprogrammable Test Registers

The AD7708 and AD7718 contain two test registers. The bits in these test registers control the test modes of these ADCs which are used for the testing of the device. *The user is advised not to change the contents of these registers.*

AD7708/AD7718

Configuring the AD7708/AD7718

All user-accessible registers on the AD7708 and AD7718 are accessed via the serial interface. Communication with any of these registers is initiated by first writing to the Communications Register. Figures 16, 17, and 18 show flow diagrams for initializing the ADC, a sequence for calibrating the ADC channels, and a routine that cycles through and reads all channels. Figure 16 shows a flowchart detailing necessary programming steps required to initialize the ADC. The following are the general programming steps required:

1. Configure and initialize the microcontroller or microprocessor serial port.
2. Initialize the AD7708/AD7718 by configuring the following registers:
 - a. IOCON to configure the digital I/O port.
 - b. FILTER to configure the update rate for each channel.
 - c. ADCCON to select the active input channel, select the analog input range, and select unipolar or bipolar operation.
 - d. MODE to configure the operating mode. The mode register selects chop or nonchop operation, buffered/unbuffered operation of the AINCOM input, 8-/10-channel mode of operation and reference select along with the selection of conversion, calibration or idle modes of operation.

All operations consist of a write to the communications register to specify the next operation as a write to a specified register. Data is then written to the specified register. When each sequence is complete, the ADC defaults to waiting for another write to the communications register to specify the next operation.

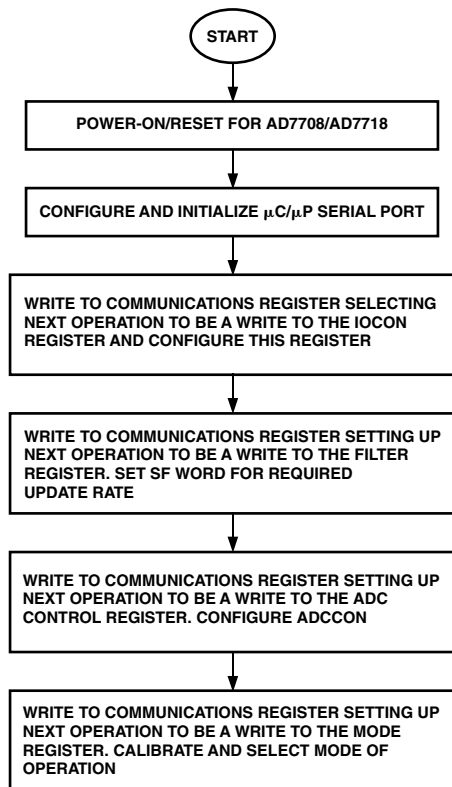

Figure 16. Initializing AD7708/AD7718

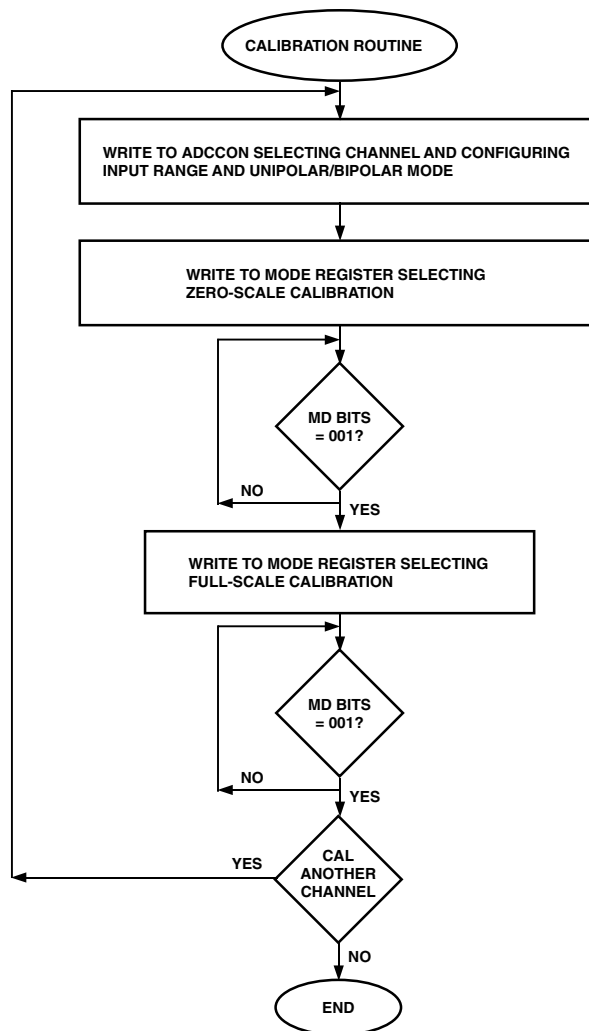

Figure 17. Calibrating the AD7708/AD7718

Figure 17 shows a flowchart detailing necessary programming steps required when calibrating the AD7708/AD7718. The AD7708/AD7718 have dedicated calibration register pairs for each of the fully-differential input channels. Having a dedicated register pair per channel allows each channel to be calibrated as part of the initialization and the ADC picks up the relevant coefficients for each channel during normal operation. When operating in pseudo-differential mode channels share calibration register pairs. Channels that share coefficients should be configured with the same operating conditions to avoid having to calibrate each time a channel is switched, especially with chop mode disabled. The AD7708/AD7718 are factory-calibrated with chop mode enabled and, therefore, if the ADC is operated at the same conditions as the factory-calibration field calibrations will not be required. Extremely low offset error and offset and gain drift errors are a by product of the chopping scheme. When operating with chop mode disabled, the user can achieve faster throughput times. An offset calibration is required with chop disabled when a gain or temperature change occurs. The following are the general programming steps required when calibrating a channel on the AD7708/AD7718.

1. Write to the ADCCON register to select the channel to be calibrated, its input range, and operation in unipolar or bipolar mode.
2. Write to the mode register selecting chop or nonchop mode of operation, select the reference, buffered/unbuffered operation on the AINCOM, and select zero-scale offset calibration. Zero-scale calibration can be either self-calibration, where the ADC determines the zero point internal to the ADC, or a system calibration where the user must supply the zero-scale voltage to the input for the duration of the calibration.
3. The calibration is initiated following the write to the mode register. The user then needs to determine when the calibration is complete. This can be performed in two ways, by polling the $\overline{\text{RDY}}$ pin or flag or by monitoring the MD2, MD1, MD0 bits in the mode register. These bits are reset to 0, 0, 1 when the calibration is complete. The flowchart uses polling of the mode bits in the mode register to determine when the calibration is complete.
4. The next step is to perform the full-scale calibration. Full-scale calibration can be a self-calibration or system calibration. Using system calibration the user must supply the full-scale signal to the analog inputs for the duration of the calibration. Again the MD2, MD1, MD0 bits in the mode register are monitored to determine when the calibration is complete.

Figure 18 shows a flowchart detailing the necessary programming steps required to cycle through and read data results from all channels in a multiplexed application. This flowchart assumes that all channels have been previously calibrated. The following are the general programming steps required when reading all channels in a multiplexed application.

1. The AD7708/AD7718 is put into continuous conversion mode. In this mode the part continually converts on the specified channel and the $\overline{\text{RDY}}$ line indicates when valid data is available to be read from the data register.
2. The ADCCON register is written to select the channel for conversion, its input range and operation is unipolar/bipolar mode.
3. In this flowchart hardware polling of the $\overline{\text{RDY}}$ line is performed to determine when it is valid to read data from the converter. When $\overline{\text{RDY}}$ is low, valid data is available in the data register. The $\overline{\text{RDY}}$ line is set high on a channel change and will not go low until a new valid data word is available. Alternatively, the RDY bit in the status register can be polled in software to determine when to read data from the converter.

4. When the data is read, increment the channel address pointer to select the next channel, poll the $\overline{\text{RDY}}$ pin, or RDY bit in the status register, and again read the data. Continue until all channels have been read.

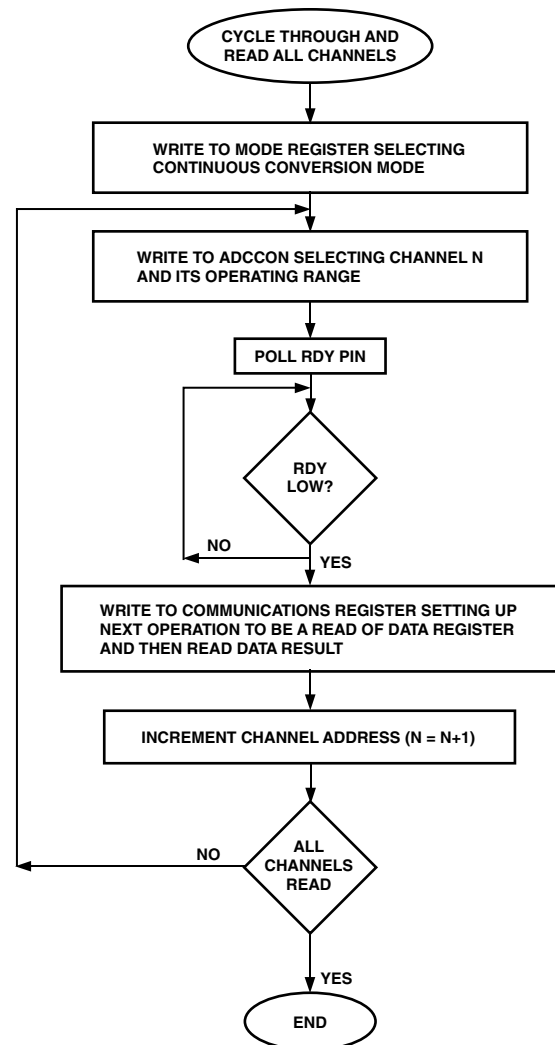

Figure 18. Multichannel Read Operation

AD7708/AD7718

DIGITAL INTERFACE

As previously outlined, the AD7708/AD7718's programmable functions are controlled using a set of on-chip registers. Data is written to these registers via the part's serial interface and read access to the on-chip registers is also provided by this interface. All communications to the part must start with a write operation to the Communications Register. After power-on or RESET, the device expects a write to its Communications Register. The data written to this register determines whether the next operation to the part is a read or a write operation and also determines to which register this read or write operation occurs. Therefore, write access to any of the other registers on the part starts with a write operation to the Communications Register followed by a write to the selected register. A read operation from any other register on the part (including the output data register) starts with a write operation to the Communications Register followed by a read operation from the selected register.

The AD7708/AD7718s serial interface consists of five signals, \overline{CS} , SCLK, DIN, DOUT and \overline{RDY} . The DIN line is used for transferring data into the on-chip registers while the DOUT line is used for accessing data from the on-chip registers. SCLK is the serial clock input for the device and all data transfers (either on DIN or DOUT) take place with respect to this SCLK signal. The \overline{RDY} line is used as a status signal to indicate when data is ready to be read from the device's data register. \overline{RDY} goes low when a new data word is available in the output register. It is reset high when a read operation from the data register is complete. It also goes high prior to the updating of the output register to indicate when not to read from the device to ensure that a data read is not attempted while the register is being updated. \overline{CS} is used to select the device. It can be used to decode these devices in systems where a number of parts are connected to the serial bus.

Figures 2 and 3 show timing diagrams for interfacing to the AD7708/AD7718 with \overline{CS} used to decode the part. Figure 3 is for a read operation from the AD7708/AD7718 output shift register while Figure 2 shows a write operation to the input shift register. It is possible to read the same data twice from the output register even though the \overline{RDY} line returns high after the first read operation. Care must be taken, however, to ensure that the read operations have been completed before the next output update is about to take place.

The serial interface can operate in three-wire mode by tying the \overline{CS} input low. In this case, the SCLK, DIN and DOUT lines are used to communicate with the device and the status of the \overline{RDY} bit can be obtained by interrogating the STATUS Register. This scheme is suitable for interfacing to microcontrollers. If \overline{CS} is required as a decoding signal, it can be generated from a port bit. For microcontroller interfaces, it is recommended that the SCLK idles high between data transfers.

The AD7708/AD7718 can also be operated with \overline{CS} used as a frame synchronization signal. This scheme is suitable for DSP interfaces. In this case, the first bit (MSB) is effectively clocked out by \overline{CS} since \overline{CS} would normally occur after the falling edge of SCLK in DSPs. The SCLK can continue to run between data transfers provided the timing numbers are obeyed.

The serial interface can be reset by exercising the \overline{RESET} input on the part. It can also be reset by writing a series of 1s on the DIN input. If a Logic 1 is written to the AD7708/AD7718 DIN line for at least 32 serial clock cycles, the serial interface is reset. This ensures that in three-wire systems, if the interface is lost

either via a software error or by some glitch in the system, it can be reset back to a known state. This state returns the interface to where the ADC is expecting a write operation to its Communications Register. This operation resets the contents of all registers to their power-on-reset values.

Some microprocessor or microcontroller serial interfaces have a single serial data line. In this case, it is possible to connect the ADC's DOUT and DIN lines together and connect them to the single data line of the processor. A 10 k Ω pull-up resistor should be used on this single data line. In this case, if the interface is lost, because the read and write operations share the same line, the procedure to reset it back to a known state is somewhat different than previously described. It requires a read operation of 24 serial clocks followed by a write operation where a Logic 1 is written for at least 32 serial clock cycles to ensure that the serial interface is back into a known state.

MICROCOMPUTER/MICROPROCESSOR INTERFACING

The flexible serial interface allows for easy interface to most microcomputers and microprocessors. The flowcharts of Figures 16, 17, and 18 outline the sequence that should be followed when interfacing a microcontroller or microprocessor to the AD7708/AD7718. Figures 19, 20, and 21 show some typical interface circuits.

The serial interface on the AD7708/AD7718 is capable of operating from just three wires and is compatible with SPI interface protocols. The three-wire operation makes the part ideal for isolated systems where minimizing the number of interface lines minimizes the number of opto-isolators required in the system. The serial clock input is a Schmitt-triggered input to accommodate slow edges from optocouplers. The rise and fall times of other digital inputs to the AD7708/AD7718 should be no slower than 1 μ s.

Most of the registers on the AD7708/AD7718 are 8-bit registers, which facilitates easy interfacing to the 8-bit serial ports of microcontrollers. The Data Register on the AD7718 is 24 bits wide, the ADC data register on the AD7708 is 16 bits wide, and the offset and gain registers are 16-bit registers on the AD7708 and 24-bit registers on the AD7718; however, data transfers to these registers can consist of multiple 8-bit transfers to the serial port of the microcontroller. DSP processors and microprocessors generally transfer 16 bits of data in a serial data operation. Some of these processors, such as the ADSP-2105, have the facility to program the amount of cycles in a serial transfer. This allows the user to tailor the number of bits in any transfer to match the register length of the required register in the AD7708/AD7718.

Even though some of the registers on the AD7708/AD7718 are only eight bits in length, communicating with two of these registers in successive write operations can be handled as a single 16-bit data transfer if required. For example, if the Filter Register is to be updated, the processor must first write to the Communications Register (saying that the next operation is a write to the Filter Register) and then write eight bits to the Filter Register. If required, this can all be done in a single 16-bit transfer because once the eight serial clocks of the write operation to the Communications Register have been completed, the part immediately sets itself up for a write operation to the Filter Register.

AD7708/AD7718 to 68HC11 Interface

Figure 19 shows an interface between the AD7708/AD7718 and the 68HC11 microcontroller. The diagram shows the minimum (3-wire) interface with \overline{CS} on the AD7708/AD7718 hardwired low. In this scheme, the RDY bit of the Status Register is monitored to determine when the Data Register is updated. An alternative scheme, which increases the number of interface lines to four, is to monitor the \overline{RDY} output line from the AD7708/AD7718. The monitoring of the \overline{RDY} line can be done in two ways. First, \overline{RDY} can be connected to one of the 68HC11's port bits (such as PC0), which is configured as an input. This port bit is then polled to determine the status of \overline{RDY} . The second scheme is to use an interrupt driven system, in which case the \overline{RDY} output is connected to the IRQ input of the 68HC11. For interfaces that require control of the \overline{CS} input on the AD7708/AD7718, one of the port bits of the 68HC11 (such as PC1), which is configured as an output, can be used to drive the \overline{CS} input.

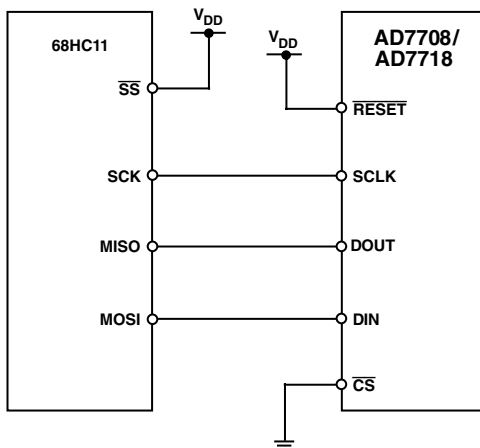

Figure 19. AD7708/AD7718-to-68HC11 Interface

The 68HC11 is configured in the master mode with its CPOL bit set to a Logic 1 and its CPHA bit set to a Logic 1. When the 68HC11 is configured like this, its SCLK line idles high between data transfers. The AD7708/AD7718 is not capable of full duplex operation. If the AD7708/AD7718 is configured for a write operation, no data appears on the DOUT lines even when the SCLK input is active. Similarly, if the AD7708/AD7718 is configured for a read operation, data presented to the part on the DIN line is ignored even when SCLK is active.

AD7708/AD7718-to-8051 Interface

An interface circuit between the AD7708/AD7718 and the 8XC51 microcontroller is shown in Figure 20. The diagram shows the minimum number of interface connections with \overline{CS} on the AD7708/AD7718 hardwired low. In the case of the 8XC51 interface the minimum number of interconnects is just two. In this scheme, the RDY bit of the Status Register is monitored to determine when the Data Register is updated. The alternative scheme, which increases the number of interface lines to three, is to monitor the \overline{RDY} output line from the AD7708/AD7718. The monitoring of the \overline{RDY} line can be done in two ways. First, \overline{RDY} can be connected to one of the 8XC51's port bits (such as P1.0) which is configured as an input. This port bit is then polled to determine the status of \overline{RDY} . The second scheme is to use an interrupt-driven system, in which case the \overline{RDY} output is connected to the INT1 input of the 8XC51. For interfaces that require control of the \overline{CS} input on the AD7708/AD7718, one of the port bits of the 8XC51 (such as P1.1), which is configured as an output, can be used to drive the \overline{CS} input. The 8XC51 is configured in its Mode 0 serial interface mode. Its serial interface contains a single data line. As a result, the DOUT and DIN pins of the AD7708/AD7718 should be connected together with a 10 k Ω pull-up resistor. The serial clock on the 8XC51 idles high between data transfers. The 8XC51 outputs the LSB first in a write operation, while the AD7708/AD7718 expects the MSB first so the data to be transmitted has to be rearranged before being written to the output serial register. Similarly, the AD7708/AD7718 outputs the MSB first during a read operation while the 8XC51 expects the LSB first. Therefore, the data read into the serial buffer needs to be rearranged before the correct data word from the AD7708/AD7718 is available in the accumulator.

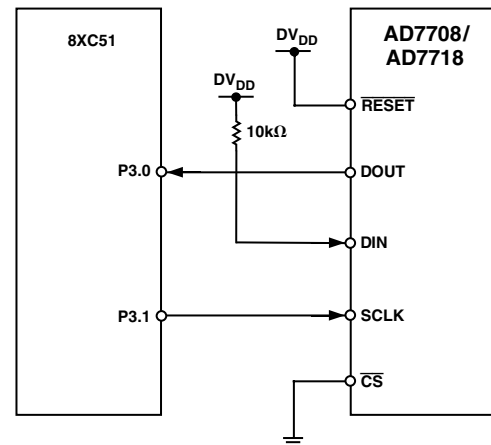

Figure 20. AD7708/AD7718-to-8XC51 Interface

AD7708/AD7718

AD7708/AD7718-to-ADSP-2103/ADSP-2105 Interface

Figure 21 shows an interface between the AD7708/AD7718 and the ADSP-2103/ADSP-2105 DSP processor. In the interface shown, the RDY bit of the Status Register is again monitored to determine when the Data Register is updated. The alternative scheme is to use an interrupt-driven system, in which case the RDY output is connected to the IRQ2 input of the ADSP-2103/ADSP-2105. The serial interface of the ADSP-2103/ADSP-2105 is set up for alternate framing mode. The $\overline{\text{RFS}}$ and $\overline{\text{TFS}}$ pins of the ADSP-2103/ADSP-2105 are configured as active low outputs and the ADSP-2103/ADSP-2105 serial clock line, SCLK, is also configured as an output. The $\overline{\text{CS}}$ for the AD7708/AD7718 is active when either the RFS or TFS outputs from the ADSP-2103/ADSP-2105 are active. The serial clock rate on the ADSP-2103/ADSP-2105 should be limited to 3 MHz to ensure correct operation with the AD7708/AD7718.

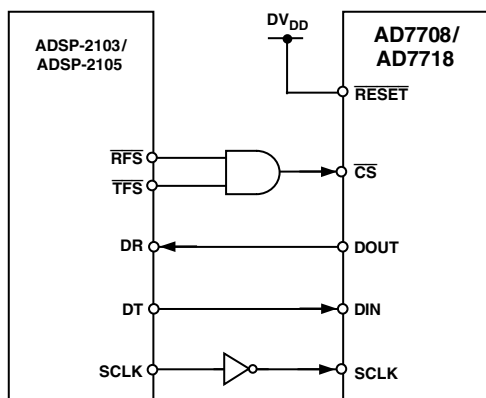

Figure 21. AD7708/AD7718-to-ADSP-2103/ADSP-2105 Interface

BASIC CONFIGURATION

The basic connection diagram for the AD7708/AD7718 in 10-channel mode is shown in Figure 22. This shows both the AV_{DD} and DV_{DD} pins of the converters being driven from the analog 5 V supply. Some applications will have AV_{DD} and DV_{DD} driven from separate supplies. AV_{DD} and DV_{DD} can be operated independently of each other, allowing the device to be operated with 5 V analog supply and 3 V digital supply or vice versa. The parts can be operated in 8- or 10-channel configurations. In 8-channel mode the user has two reference input options. This allows the user to operate some channels in ratiometric mode and others in absolute measurement mode. In 10-channel mode only one reference option is available. An AD780/REF195, precision 2.5 V reference, provides the reference source for the part. A quartz crystal or ceramic resonator provides the 32.768 kHz master clock source for the part. In some cases, it will be necessary to connect capacitors on the crystal or resonator to ensure that it does not oscillate at overtones of its fundamental operating frequency. The values of capacitors will vary, depending on the manufacturer's specifications.

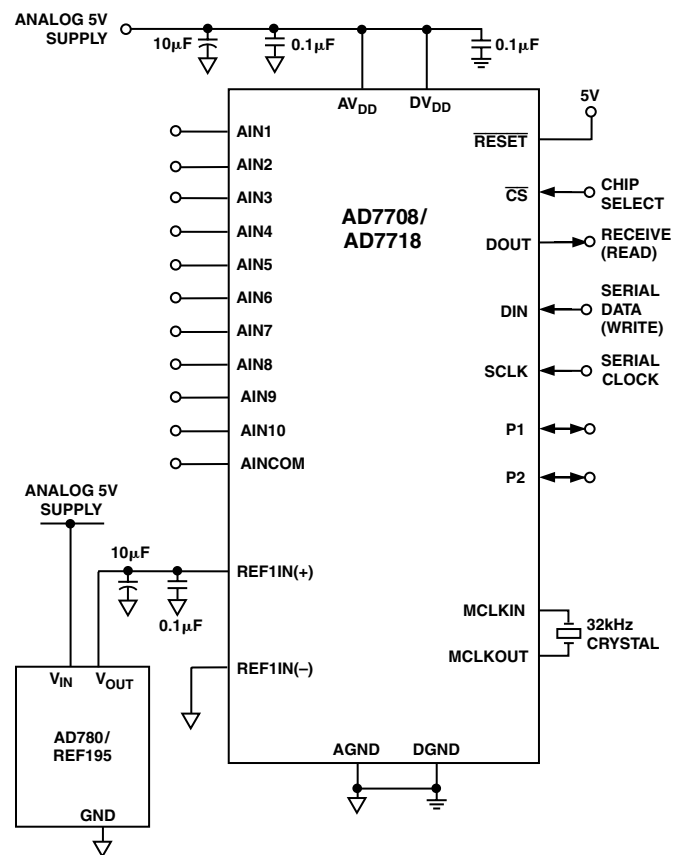

Figure 22. Basic Configuration for 10-Channel Mode

Analog Input Channels

The input multiplexer on AD7708/AD7718 can be configured as either an 8- or 10-input channel device. This configuration is selected using the CHCON bit in the MODE register. With CHCON = 0 (Figure 23), the user has eight input channels; these can be configured as eight pseudo-differential input channels with respect to AINCOM or four fully-differential input channels.

In this configuration the user can select REFIN1 or REFIN 2 as the reference for the selected channel using the REFSEL bit in the mode register.

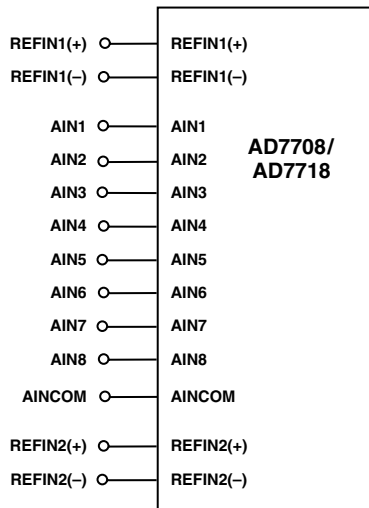

Figure 23. Analog Input and Reference Options with CHCON = 0

With CHCON = 1 (Figure 24), the user has 10 input channels that can be configured as 10 pseudo-differential input channels with respect to AINCOM or as five fully-differential input channels. The contents of the CHCON bit overrides the REFSEL bit. If the ADC is configured in five fully-differential or 10 pseudo-differential input channel mode, the REFSEL bit setting is irrelevant as only REFIN1 is available. Channel selection Bits CH3, CH2, CH1, and CH0 in the ADCCON register select the input channel.

The input multiplexer switches the selected input channel to the on-chip buffer amplifier and sigma-delta converter. When the analog input channel is switched, the settling time of the part must elapse before a new valid word is available from the ADC. If any two inputs are configured as a differential input pair, this input is buffered and the common-mode and absolute input voltage is restricted to a range between AGND + 100 mV and $AV_{DD} - 100$ mV. Care must be taken in setting up the common-mode voltage and input voltage range to ensure that these limits are not exceeded, otherwise there will be a degradation in linearity and noise performance.

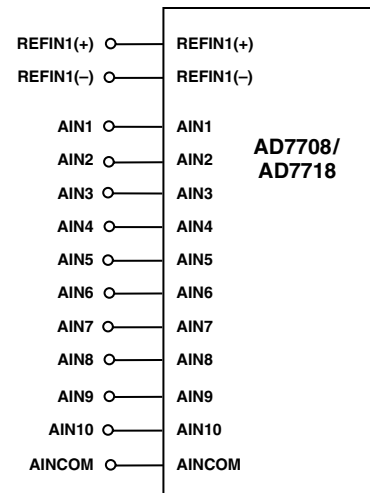

Figure 24. Analog Input and Reference Options with CHCON = 1

Single-Ended Operation

The NEGBUF bit in the mode register is used to control the operation of the input buffer on the AINCOM pin when configured for pseudo-differential mode of operation. If cleared, the analog negative input (AINCOM) is unbuffered. It should be noted that the unbuffered input path on the AINCOM provides a dynamic load to the driving source. Therefore, resistor/capacitor combinations on this input pin can cause dc gain errors depending on the output impedance of the source that is driving the AINCOM input. AINCOM is tied to AGND for single-ended operation. This enables all pseudo-differential inputs to act as single-ended analog inputs. All analog inputs still operate in buffered mode and their common-mode and absolute input voltage is restricted to a range between AGND + 100 mV and $AV_{DD} - 100$ mV.

Chop Mode of Operation ($\overline{CHOP} = 0$)

The signal chain on the AD7708/AD7718 can be operated with chopping enabled or disabled. Chopping is enabled or disabled using the CHOP bit in the mode register. The default mode of operation is for chop enabled ($\overline{CHOP} = 0$). Optimum performance in terms of minimizing offset error and offset and gain drift performance is achieved when chopping is enabled. The digital filter decimation rate, and consequently the output data rate, is programmable via the SF word loaded to the filter register. Output data rates vary from 5.35 Hz (186.77 ms) to 105.03 Hz (9.52 ms). The output data rate $f_{ADC} = \frac{f_{MOD}}{24 \times SF}$.

The overall frequency response from the digital filter with chopping enabled is the product of a sinc³ and a sinc response. There are sinc³ notches at integer multiples of $3 \times f_{ADC}$ and there are sinc notches at odd integer multiples of $f_{ADC}/2$. Normal mode rejection is the major function of the digital filter on the AD7708/AD7718. The normal mode 50 ± 1 Hz rejection with an SF word of 82 is typically -100 dB. The 60 ± 1 Hz rejection with SF = 68 is typically -100 dB. Simultaneous 50 Hz and 60 Hz rejection of better than 60 dB is achieved with an SF of 69 and gives a data update rate of 19.8 Hz and a channel settling time of 101 ms. The AD7708/AD7718 are factory-calibrated so field calibration will only be required if the ADC is operated at temperatures that differ substantially from the factory-calibration conditions.

AD7708/AD7718

Nonchop Mode of Operation ($\overline{\text{CHOP}} = 1$)

Chopping is enabled and disabled using the $\overline{\text{CHOP}}$ bit in the mode register. Chopping is disabled by loading a 1 to the chop bit in the mode register. With chopping disabled the available output rates vary from 16.06 Hz (62.26 ms) to 1365.33 Hz (0.73 ms). The range of applicable SF words is from 3 to 255. When the chopping is disabled the channel output data rate is increased by a factor of 3 compared to the situation when chopping is enabled and using the same SF word. When used in multiplexed applications, operation with chop disabled will offer the best throughput time when cycling through all channels. The drawback with chop disabled is that the drift performance is degraded and calibration is required following a gain change or significant temperature change. The output update and filter decimation rate is again controlled by the SF word loaded to the filter register. The digital filter frequency response places sinc^3 notches at integer multiples of the update rate. The output

update rate $f_{\text{ADC}} = \frac{f_{\text{MOD}}}{8 \times \text{SF}}$. The AD7708/AD7718 are targeted

at multiplexed applications and therefore operating with chop disabled optimizes channel throughput time. One of the key requirements in these applications is the selection of an SF word so as to obtain the maximum filter rejection at 50 Hz and 60 Hz while minimizing the channel throughput rate. This is achieved with an SF word of 75 giving 57 dB rejection at 50 Hz, and 60 dB rejection at 60 Hz while offering a channel throughput time of 55 ms. Using a higher SF word of 151, 50 Hz and 60 Hz rejection can be maximized at 60 dB with a channel throughput rate of 110 ms. An SF word of 255 gives maximum rejection at both 50 Hz and 60 Hz but the channel throughput rate is restricted to 186 ms. Table XXI shows a quick comparison of normal mode 50 Hz and 60 Hz rejection, settling time, and update rate for a selection of SF words with chop both enabled and disabled.

Programmable Gain Amplifier

The output from the buffer is applied to the input of the programmable gain amplifier (PGA). The PGA gain range is programmed via the range bits in the ADCCON register. The PGA has eight ranges. With an external 2.5 V reference applied, and a PGA setting of 128, the unipolar analog input range is 0 mV to 20 mV, while the bipolar analog input range is ± 20 mV. With a PGA setting of 1, the unipolar and bipolar input ranges are 2.56 V. When operating with chop mode enabled ($\overline{\text{CHOP}} = 0$), the ADC range-matching specification of 2 μV (typ) across all ranges means that calibration need only be carried out on a single range and does not have to be repeated when the PGA range is changed. This is a significant advantage when compared with similar ADCs available on the market. Typical matching across ranges is shown in Figure 25. Here, the ADC is configured in fully-differential, bipolar mode with an external 2.5 V reference, while an analog input voltage of just greater than 19 mV is forced on its analog inputs. The ADC continuously converts the dc voltage at an update rate of 5.35 Hz, i.e., SF = FFhex, 800 conversion results in total are gathered. The first 100 results are gathered with the ADC operating with a PGA setting of 128.

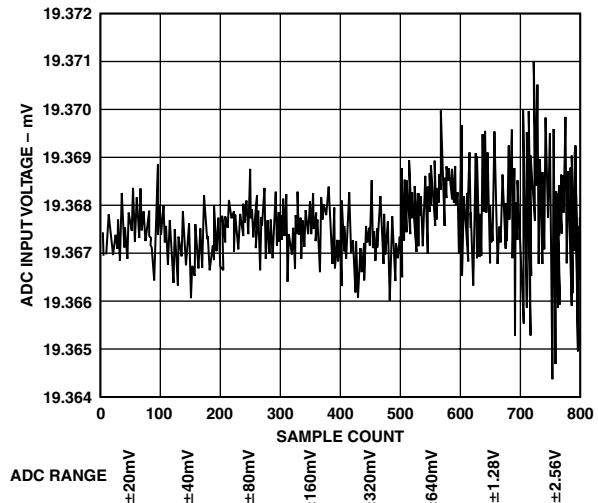

Figure 25. ADC Range Matching

The PGA setting is then switched to 64 and 100 more results are gathered, and so on until the last 100 samples are gathered with a PGA setting of 1. From Figure 25, the variation in the sample mean through each range, i.e., the range matching, is seen to be of the order of 2 μV . When operating with chop mode disabled ($\overline{\text{CHOP}} = 1$), new calibration data is needed (but not necessarily a new calibration) to remove offset error when switching channels.

Bipolar/Unipolar Configuration

The analog inputs on the AD7708/AD7718 can accept either unipolar or bipolar input voltage ranges. Bipolar input ranges does not imply that the part can handle negative voltages with respect to system AGND. Signals in pseudo-differential mode are referenced to AINCOM, while in fully differential mode they are referenced to the negative input of the differential input. For example, if AINCOM is 2.5 V and the AD7708/AD7718 AIN1 analog input is configured for an analog input range of 0 mV to +20 mV, the input voltage range on the AIN1 input is 2.5 V to 2.52 V. If AINCOM is 2.5 V and the AD7708/AD7718 is configured for an analog input range of ± 1.28 V, the analog input range on the AIN1 input is 1.22 V to 3.78 V (i.e., $2.5 \text{ V} \pm 1.28 \text{ V}$). Bipolar or unipolar options are chosen by programming U/B bit in the ADCCON register. Programming for either unipolar or bipolar operation does not change any of the input signal conditioning; it simply changes the data output coding and the points on the transfer function where calibrations occur.

Data Output Coding

When the AD7718 is configured for unipolar operation, the output coding is natural (straight) binary with a zero differential input voltage resulting in a code of 000 . . . 000, a midscale voltage resulting in a code of 100 . . . 000, and a full-scale input voltage resulting in a code of 111 . . . 111. The output code for any analog input voltage can be represented as follows:

$$\text{Code} = (\text{AIN} \times \text{GAIN} \times 2^{24}) / (1.024 \times V_{\text{REF}})$$

where

AIN is the analog input voltage,
GAIN is the PGA gain, i.e., 1 on the 2.5 V range and 128 on the 20 mV range.

The output code for any analog input voltage on the AD7708 can be represented as follows:

$$\text{Code} = (\text{AIN} \times \text{GAIN} \times 2^{16}) / (1.024 \times V_{REF})$$

where

AIN is the analog input voltage,
GAIN is the PGA gain, i.e., 1 on the 2.5 V range and 128 on the 20 mV range.

When an ADC is configured for bipolar operation, the coding is offset binary with a negative full-scale voltage resulting in a code of 000 . . . 000, a zero differential voltage resulting in a code of 100 . . . 000, and a positive full-scale voltage resulting in a code of 111 . . . 111. The output code from the AD7718 for any analog input voltage can be represented as follows:

$$\text{Code} = 2^{23} \times [(\text{AIN} \times \text{GAIN} / (1.024 \times V_{REF})) + 1]$$

where

AIN is the analog input voltage,
GAIN is the PGA gain, i.e., 1 on the ± 2.5 V range and 128 on the ± 20 mV range.

The output code from the AD7708 for any analog input voltage can be represented as follows:

$$\text{Code} = 2^{15} \times [(\text{AIN} \times \text{GAIN} / (1.024 \times V_{REF})) + 1]$$

where

AIN is the analog input voltage,
GAIN is the PGA gain, i.e., 1 on the ± 2.5 V range and 128 on the ± 20 mV range.

Oscillator Circuit

The AD7708/AD7718 is intended for use with a 32.768 kHz watch crystal or ceramic resonator. A PLL internally locks onto a multiple of this frequency to provide a stable 4.194304 MHz clock for the ADC. The modulator sample rate is the same as the oscillator frequency.

The start-up time associated with 32 kHz crystals is typically 300 ms. The OSPD bit in the mode register can be used to prevent the oscillator from powering down when the AD7708/AD7718 is placed in power-down mode. This avoids having to wait 300 ms after exiting power-down to start a conversion at the expense of raising the power-down current.

Reference Input

The AD7708/AD7718 has a fully differential reference input capability. When the AD7708/AD7718 is configured in 8-channel mode (CHCON = 0) the user has the option of selecting one of two reference options. This allows the user to configure some channels, for example, for ratiometric operation while others can be configured for absolute value measurements. The REFSEL bit in the mode register allows selection of the required reference. If the REFSEL bit is *cleared*, the reference selected is REFIN1(+)–REFIN1(–) for the active channel. If this bit is *set*, the reference selected is REFIN2(+)–REFIN2(–) for the active channel. When the AD7708/AD7718 is configured in 10-channel mode (CHCON = 1) the user has only one reference option (REFIN1). The contents of the CHCON bit overrides the REFSEL bit. If

the ADC is configured in five fully-differential or 10 pseudo-differential input channel mode, the REFSEL bit setting is irrelevant as only one reference input is available.

The common-mode range for these differential inputs is from AGND to AV_{DD}. The reference inputs are unbuffered and therefore excessive R-C source impedances will introduce gain errors. The nominal reference voltage for specified operation, VREF, (REFIN1(+)-REFIN1(–) or REFIN2(+)-REFIN2(–)), is 2.5 V, but the AD7708/AD7718 is functional with reference voltages from 1 V to AV_{DD}. In applications where the excitation (voltage or current) for the transducer on the analog input also drives the reference voltage for the part, the effect of the low frequency noise in the excitation source will be removed as the application is ratiometric. If the AD7708/AD7718 is used in a nonratiometric application, a low noise reference should be used. Recommended reference voltage sources for the AD7708/AD7718 include the AD780, REF43, and REF192. It should also be noted that the reference inputs provide a high impedance, dynamic load. Because the input impedance of each reference input is dynamic, resistor/capacitor combinations on these inputs can cause dc gain errors, depending on the output impedance of the source that is driving the reference inputs. Reference voltage sources, like those recommended above (e.g., AD780) will typically have low output impedances and are therefore tolerant of having decoupling capacitors on the REFIN(+) without introducing gain errors in the system. Deriving the reference input voltage across an external resistor will mean that the reference input sees a significant external source impedance. External decoupling on the REFIN(+) and REFIN(–) pins would not be recommended in this type configuration.

RESET Input

The RESET input on the AD7708/AD7718 resets all the logic, the digital filter and the analog modulator while all on-chip registers are reset to their default state. RDY is driven high and the AD7708/AD7718 ignores all communications to any of its registers while the RESET input is low. When the RESET input returns high the AD7708/AD7718 operates with its default setup conditions and it is necessary to set up all registers and carry out a system calibration if required after a RESET command.

Power-Down Mode

Loading 0, 0, 0 to the MD2, MD1, MD0 bits in the ADC mode register places the ADC in device power-down mode. Device power-down mode is the default condition for the AD7708/AD7718 on power-up. The ADC retains the contents of all its on-chip registers (including the data register) while in power-down. The device power-down mode does not affect the digital interface, but does affect the status of the RDY pin. Writing the AD7708/AD7718 into power-down will reset the RDY line high. Placing the part in power-down mode reduces the total current (AI_{DD} + DI_{DD}) to 31 μ A max when the part is operated at 5 V and the oscillator allowed to run during power-down mode. With the oscillator shut down the total I_{DD} is typically 9 μ A.

AD7708/AD7718

Calibration

The AD7708/AD7718 provides four calibration modes that can be programmed via the mode bits in the mode register. One of the major benefits of the AD7708/AD7718 is that it is factory-calibrated with chopping enabled as part of the final test process with the generated coefficients stored within the ADC. At power-on, the factory gain calibration coefficients are automatically loaded to the gain calibration registers on the AD7708/AD7718. This gives excellent offset and drift performance and it is envisaged that in the majority of applications the user will not need to perform any field calibrations. Also, because factory gain calibration coefficients (generated at 25°C ambient) are automatically present at power-on, an internal full-scale calibration will only be required if the part is being operated at temperatures significantly different from 25°C.

When chopping is disabled ($\overline{\text{CHOP}} = 1$) the AD7708/AD7718 requires an offset calibration or new calibration coefficients on range changing or when significant temperature changes occur as the signal chain is no longer chopped and offset and drift errors are no longer removed as part of the conversion process.

The factory-calibration values for any one channel will be overwritten if any one of the four calibration options is initiated. The AD7708/AD7718 offers “internal” or “system” calibration facilities. For full calibration to occur, the calibration logic must record the modulator output for two different input conditions. These are “zero-scale” and “full-scale” points. These points are derived by performing a conversion on the different input voltages provided to the input of the modulator during calibration. The result of the “zero-scale” calibration conversion is stored in the Offset Calibration Registers for the appropriate channel. The result of the “full-scale” calibration conversion is stored in the Gain Calibration Registers. With these readings, the calibration logic can calculate the offset and the gain slope for the input-to-output transfer function of the converter. During an “internal” zero-scale or full-scale calibration, the respective “zero” input and “full-scale” input are automatically connected to the ADC input pins internally to the device. A “system” calibration, however, expects the system zero-scale and system full-scale voltages to be applied to the external ADC pins before the calibration mode is initiated. In this way external ADC errors are taken into account and minimized as a result of system calibration. It should also be noted that to optimize calibration accuracy, all AD7708/AD7718 ADC calibrations are carried out automatically at the slowest update rate with chop enabled. When chop mode is disabled calibrations are carried out at the update rate defined by the SF word in the filter register.

Internally in the AD7708/AD7718, the coefficients are normalized before being used to scale the words coming out of the digital filter. The offset calibration coefficient is subtracted from the result prior to the multiplication by the gain coefficient. With chopping disabled AD7708/AD7718 ADC specifications will only apply after a zero-scale calibration at the operating point of interest. From an operational point of view, a calibration should be treated like another ADC conversion. A zero-scale calibration (if required) should always be carried out before a full-scale

calibration. System software should monitor the RDY bit in the STATUS register to determine end of calibration via a polling sequence or interrupt driven routine.

Grounding and Layout

Since the analog inputs and reference inputs are differential, most of the voltages in the analog modulator are common-mode voltages. The excellent common-mode rejection of the part will remove common-mode noise on these inputs. The analog and digital supplies to the AD7708/AD7718 are independent and separately pinned out to minimize coupling between the analog and digital sections of the device. The AD7708/AD7718 can be operated with 5 V analog and 3 V digital supplies or vice versa. The digital filter will provide rejection of broadband noise on the power supplies, except at integer multiples of the modulator sampling frequency. The digital filter also removes noise from the analog and reference inputs provided these noise sources do not saturate the analog modulator. As a result, the AD7708/AD7718 is more immune to noise interference than a conventional high-resolution converter. However, because the resolution of the AD7708/AD7718 is so high and the noise levels from the converter so low, care must be taken with regard to grounding and layout.

The printed circuit board that houses the ADC should be designed so the analog and digital sections are separated and confined to certain areas of the board. This facilitates the use of ground planes that can be easily separated. A minimum etch technique is generally best for ground planes as it gives the best shielding.

Although the AD7708/AD7718 has separate pins for analog and digital ground, the AGND and DGND pins are tied together internally via the substrate. Therefore, the user must not tie these two pins to separate ground planes unless the ground planes are connected together near the AD7708/AD7718.

In systems where the AGND and DGND are connected somewhere else in the system, i.e., the systems power supply, they should not be connected again at the AD7708/AD7718 or a ground loop will result. In these situations it is recommended that ground pins of the AD7708/AD7718 be tied to the AGND plane.

In any layout it is implicit that the user keep in mind the flow of currents in the system, ensuring that the paths for all currents are as close as possible to the paths the currents took to reach their destinations. Avoid forcing digital currents to flow through the AGND.

Avoid running digital lines under the device as these will couple noise onto the die. The analog ground plane should be allowed to run under the AD7708/AD7718 to prevent noise coupling. The power supply lines to the AD7708/AD7718 should use as wide a trace as possible to provide low impedance paths and reduce the effects of glitches on the power supply line. Fast switching signals like clocks should be shielded with digital ground to avoid radiating noise to other sections of the board and clock signals should never be run near the analog inputs. Avoid crossover of digital and analog signals. Traces on opposite sides of the board should run at right angles to each other. This will reduce the effects of feedthrough through the board. A microstrip technique is by far the best, but is not always possible with a double-sided board. In this technique, the component side of the board is dedicated to ground planes while signals are placed on the solder side.

Good decoupling is important when using high resolution ADCs. All analog supplies should be decoupled with 10 μF tantalum in parallel with 0.1 μF capacitors to AGND. To achieve the best from these decoupling components, they have to be placed as close as possible to the device, ideally right up against the device. All logic chips should be decoupled with 0.1 μF ceramic capacitors to DGND. In systems where a common supply voltage is used to drive both the AV_{DD} and DV_{DD} of the AD7708/AD7718, it is recommended that the system's AV_{DD} supply is used. This supply should have the recommended analog supply decoupling capacitors between the AV_{DD} pin of the AD7708/AD7718 and AGND and the recommended digital supply decoupling capacitor between the DV_{DD} pin of the AD7708/AD7718 and DGND.

APPLICATIONS

The AD7708/AD7718 provides a low cost, high resolution analog-to-digital function. The AD7708 offers 16-bit resolution while the AD7718 offers 24-bit resolution. The AD7708 and AD7718 are pin and function compatible. The AD7718 allows a direct upgradable path from a 16-bit to a 24-bit system with minimal software and no hardware changes. Because the analog-to-digital function is provided by a sigma-delta architecture, it makes the part more immune to noisy environments, thus making the part ideal for use in sensor measurement and in industrial and process control applications. There are two modes of operation associated with the AD7708/AD7718, chop enabled ($\overline{\text{CHOP}} = 0$) or chop disabled ($\overline{\text{CHOP}} = 1$). With chop enabled the signal chain is chopped and the device is factory-calibrated at final test in this mode. Field calibration can be avoided due to the extremely low offset and gain drifts exhibited by the converter in this mode. While operating in this mode gives optimum performance in terms of offset error and offset and gain drift performance, it offers limited throughput when cycling through all channels. With chopping disabled, the signal chain is not chopped and therefore the user needs to ensure that the ADC is calibrated on range changes and if there is a significant temperature change as the gain and offset drift performance is degraded.

The key advantage in using the AD7708/AD7718 with chopping disabled is in channel cycling applications where system throughput is of prime importance. The max conversion rate with chop disabled is 1.36 kHz compared with 105 Hz with chop enabled.

The AD7708/AD7718 also provides a programmable gain amplifier, a digital filter, and system calibration options. Thus, it provides far more system level functionality than off-the-shelf integrating ADCs without the disadvantage of having to supply a high quality integrating capacitor. In addition, using the AD7708/AD7718 in a system allows the system designer to achieve a much higher level of resolution because noise performance of the AD7708/AD7718 is significantly better than that of integrating ADCs.

The on-chip PGA allows the AD7708/AD7718 to handle an analog input voltage range as low as 10 mV full scale with $V_{\text{REF}} = 1.25 \text{ V}$. The AD7708/AD7718 can be operated in 8-channel mode with two reference input options or 10-channel mode with one reference input. Eight-channel mode allows both ratiometric or absolute measurements to be performed on any channel using the two reference input options. The differential analog inputs of the part allow this analog input range to have an absolute value anywhere between $\text{AGND} + 100 \text{ mV}$ and $\text{AV}_{\text{DD}} - 100 \text{ mV}$.

The buffer on the negative analog input can be bypassed allowing the AD7708/AD7718 be operated as eight or ten single-ended input channels. The PGA allows the user to connect transducers directly to the input of the AD7708/AD7718. The programmable gain front end on the AD7708/AD7718 allows the part to handle unipolar analog input ranges from 0 mV to +20 mV to 0 V to +2.5 V and bipolar inputs of $\pm 20 \text{ mV}$ to $\pm 2.5 \text{ V}$. Because the part operates from a single supply these bipolar ranges are with respect to a biased-up differential input.

Data Acquisition

The AD7708/AD7718, with its different configuration options (five fully-differential input or 10 pseudo-differential input channels with one reference input or four fully-differential input or eight pseudo-differential input channels with two reference inputs), is suited to low bandwidth, high resolution data acquisition systems. In addition, the 3-wire digital interface allows this data acquisition front end to be isolated with just three optoisolators. The entire system can be operated from a single 3 V or 5 V supply, provided that the input signals to the AD7708/AD7718's analog inputs are all of positive polarity.

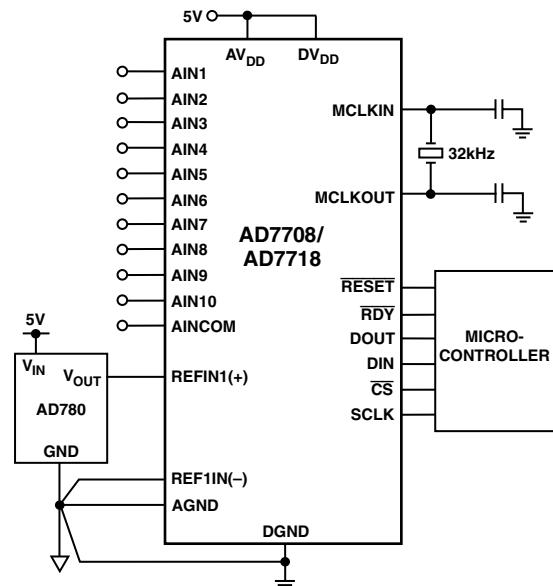

Figure 26. Data Acquisition Using the AD7708/AD7718

Programmable Logic Controllers

The AD7708/AD7718 is also suited to programmable logic controller applications. In such applications, the ADC is required to handle signals from a variety of different transducers. The AD7708/AD7718's programmable gain front end allows the part to either handle low level signals directly from a transducer or full-scale signals that have already been conditioned. The faster throughput rate and settling time of the part when operated with chopping disabled makes this the optimum mode of operation in PLC applications as an important feature in these applications is loop response time. The configuration of the AD7708/AD7718 in PLC applications is similar to that outlined for a data acquisition system and is shown in Figure 26. In this application the AD7708/AD7718 is configured in 10-channel mode, ($\text{CHCON} = 1$) and can be operated as 10 pseudo-differential inputs with respect to AINCOM or as five fully-differential input channels.

AD7708/AD7718

Converting Single-Ended Inputs

The AD7708/AD7718 generally operates in buffered mode. This places a restriction of $AGND + 100\text{ mV}$ to $AVDD - 100\text{ mV}$ on the absolute and common-mode voltages that can be applied to any input on the AD7708/AD7718.

Some applications may require the measurement of analog inputs with respect to $AGND$. To enable the AD7708/AD7718 to be used in these single-ended applications, the buffer on the $AINCOM$ can be bypassed. The $NEGBUF$ bit in the mode register controls the operation of the input buffer on the $AINCOM$ input when a channel is configured for pseudo-differential mode of operation. If *cleared*, the analog negative input ($AINCOM$) is unbuffered, allowing it to be tied to $AGND$ in single-ended input configuration. If this bit is *set*, the analog negative input ($AINCOM$) is buffered, placing a restriction on its common-mode input range. When $AINCOM$ is unbuffered, signals with a common-mode range from $AGND - 30\text{ mV}$ to $AVDD + 30\text{ mV}$ can be accommodated on this input allowing the end user to connect the $AINCOM$ input to $AGND$ and perform single-ended measurements with respect to this input. This unbuffered input path on the $AINCOM$ provides a dynamic load to the driving source. Therefore, resistor/capacitor combinations on this input pin can cause dc gain errors, depending on the output impedance of the source that is driving the $AINCOM$ input. All analog inputs still operate in buffered mode and their common-mode and absolute input voltage is restricted to a range between $AGND + 100\text{ mV}$ and $AV_{DD} - 100\text{ mV}$.

Combined Ratiometric and Absolute Value Measurement System

The AD7708/AD7718 when operated with $CHCON = 0$ can be configured for operation as four fully-differential analog inputs or eight pseudo-differential analog inputs with two fully-differential reference inputs. Having the ability to use either $REFIN1$ or $REFIN2$ with any channel during the conversion process allows the end user to make both absolute and ratiometric measurements as shown in Figure 27. In this example a fully-differential analog input ($AIN1-AIN2$) is being converted from a bridge transducer in a ratiometric manner using $REFIN1$ as the reference input for this channel. $AIN3$ is configured as a pseudo-differential input channel using $REFIN2$ to perform an absolute measurement on the potentiometer. The $REFSEL$ bit in the mode register is used to select which reference is used with the active channel during the conversion process. When the AD7708/AD7718 is configured with $CHCON = 1$, only one reference ($REFIN1$) is available. The contents of the $CHCON$ bit override the $REFSEL$ bit. If the ADC is configured in five fully-differential or 10 pseudo-differential input channel mode, the $REFSEL$ bit setting is irrelevant as only $REFIN1$ is available.

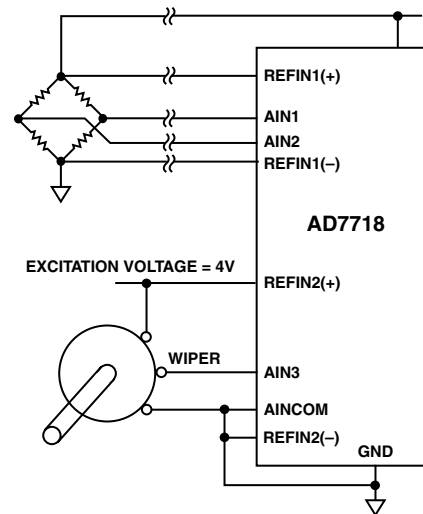

Figure 27. Absolute and Ratiometric Measurement System Using AD7718

Optimizing Throughput while Maximizing 50 Hz and 60 Hz Rejection in a Multiplexed Data Acquisition System

The AD7708/AD7718 can be optimized for one of two modes of operation. Operating the AD7708/AD7718 with chopping enabled ($\overline{\text{CHOP}} = 0$) optimizes the AD7708/AD7718 for analog performance over channel throughput. Output data rates vary from 5.35 Hz (186.77 ms) to 105.03 Hz (9.52 ms). Optimum performance, in terms of minimizing offset error and offset and gain drift performance, is achieved as a result of chopping the signal chain.

With chopping disabled the available output rates vary from 16.06 Hz (62.26 ms) to 1365.33 Hz (0.73 ms). The range of applicable SF words is from 3 to 255. When the chopping is disabled the channel output data rate is increased by a factor of 3 compared to the situation when chopping is enabled is disabled. When used in multiplexed applications, operation with chop disabled will offer the best throughput time when

cycling through all channels. The drawback with chopping disabled is that the drift performance is degraded and calibration is required following gain and temperature changes. One of the key requirements in these applications is to optimize the SF word to obtain the maximum filter rejection at 50 Hz and 60 Hz while minimizing the channel throughput rate. This is achieved with an SF word of 75 giving 57 dB rejection at 50 Hz and 60 dB rejection at 60 Hz while offering a channel throughput time of 55 ms.

Using a higher SF word of 151, 50 Hz and 60 Hz rejection can be maximized at 60 dB with a channel throughput rate of 110 ms. An SF word of 255 gives maximum rejection at both 50 Hz and 60 Hz, but the channel throughput rate is restricted to 186 ms. Table XXI gives a quick comparison of normal mode 50 Hz and 60 Hz rejection, settling time, and update rate for a selection of SF words with both chopping enabled and disabled.

Table XXI. Normal Mode 50 Hz and 60 Hz Rejection vs. Settling Time and Update Rate for a Selection of SF Words

SF Word	CHOP Disabled				CHOP Enabled			
	f_{ADC} (Hz)	t_{SETTLE} (ms)	50 Hz \pm 1 Hz Rejection (dB)	60 Hz \pm 1 Hz Rejection (dB)	f_{ADC} (Hz)	t_{SETTLE} (ms)	50 Hz \pm 1 Hz Rejection (dB)	60 Hz \pm 1 Hz Rejection (dB)
03	1365.33	2.20	0.05	0.08	N/A	N/A	N/A	N/A
13	315.08	9.52	1	1.5	105.03	19.04	21	13.6
69	59.36	50.54	42	94	19.79	101	60	94
75	54.6	54.93	57	60	18.2	110	62	66
82	49.95	60	100		16.65	180	100	53
151	27.13	110.6	60	60	9.04	221	72	63
255	16.06	186.76	77	68	5.35	373.5	93	68

OUTLINE DIMENSIONS

Dimensions shown in inches and (mm).

28-Lead Plastic SOIC
(R-28)

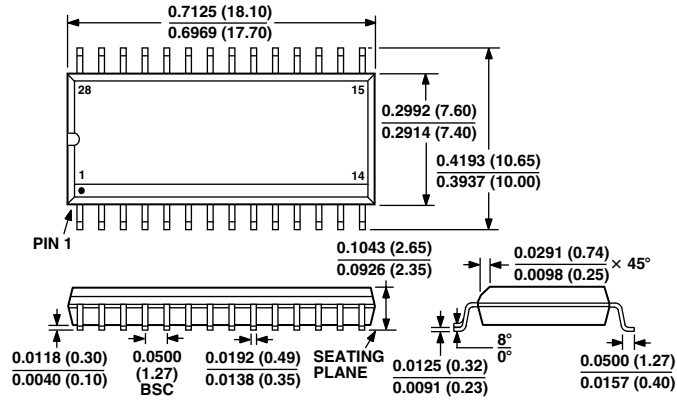

28-Lead Plastic TSSOP
(RU-28)

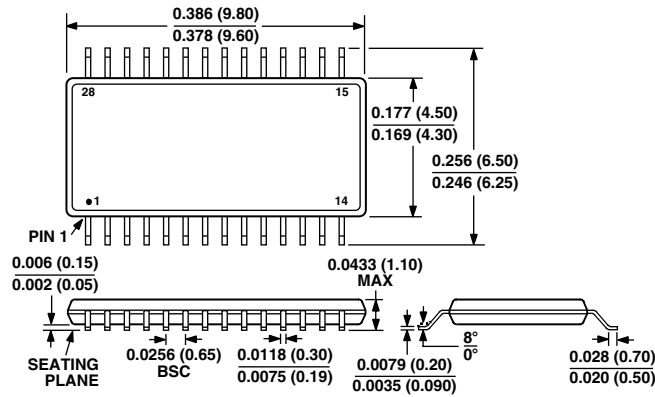



Стандарт Электрон Связь

Мы молодая и активно развивающаяся компания в области поставок электронных компонентов. Мы поставляем электронные компоненты отечественного и импортного производства напрямую от производителей и с крупнейших складов мира.

Благодаря сотрудничеству с мировыми поставщиками мы осуществляем комплексные и плановые поставки широчайшего спектра электронных компонентов.

Собственная эффективная логистика и склад в обеспечивает надежную поставку продукции в точно указанные сроки по всей России.

Мы осуществляем техническую поддержку нашим клиентам и предпродажную проверку качества продукции. На все поставляемые продукты мы предоставляем гарантию .

Осуществляем поставки продукции под контролем ВП МО РФ на предприятия военно-промышленного комплекса России , а также работаем в рамках 275 ФЗ с открытием отдельных счетов в уполномоченном банке. Система менеджмента качества компании соответствует требованиям ГОСТ ISO 9001.

Минимальные сроки поставки, гибкие цены, неограниченный ассортимент и индивидуальный подход к клиентам являются основой для выстраивания долгосрочного и эффективного сотрудничества с предприятиями радиоэлектронной промышленности, предприятиями ВПК и научно-исследовательскими институтами России.

С нами вы становитесь еще успешнее!

Наши контакты:

Телефон: +7 812 627 14 35

Электронная почта: sales@st-electron.ru

Адрес: 198099, Санкт-Петербург,
Промышленная ул, дом № 19, литера Н,
помещение 100-Н Офис 331