

i.MX 6UltraLite EVK Board Hardware User's Guide

1 Introduction

This document is the Hardware User Guide for the i.MX 6UltraLite Evaluation Kit (EVK) based on the Freescale Semiconductor i.MX 6UltraLite Applications Processor. This board is fully supported by Freescale Semiconductor. This Manual includes system setup and debugging, and provides detailed information on the overall design and usage of the EVK board from a Hardware Systems perspective.

1.1 Board overview

This EVK board is a platform designed to showcase many of the most commonly used features of the i.MX 6UltraLite Applications Processor in a small, low cost package. The i.MX 6UltraLite EVK board is an entry level development board, which gives the developer the option of becoming familiar with the processor before investing a large amount or resources in more specific designs.

Features of the i.MX 6UltraLite EVK board are:

Contents

1. Introduction	1
2. Specifications	4
3. PCB information	19
4. EVK Design Files	20
5. Contents of the Evaluation Kit	20
6. Revision history	21

Table 1. Features

Processor:	Freescale Applications Processor	MCIMX6G3CVM05AA
DRAM Memory:	Micron 4Gb DDR3L SDRAM	MT41K256M16HA-125:E
DCDC:	MPS	MP2144GJ & MP2159GJ
LDO	RICHTECK	RT9169-33GVL RT9169-18GVL RT9193-33GB
	UNION	UM1750S-00
Mass storage	MicroSD card connector	
	256Mbit QSPI Flash	
	32Gb NAND Flash (unpopulated)	
	32 Gb eMMC (unpopulated)	
Display interface	LCD connector	
	HDMI connector (no function by default)	
Ethernet	Dual RJ45 Connector for 10/100 Base-T	
USB	One USB 2.0 Standard-A host connector	
	One USB 2.0 Micro-B OTG connector	
Audio connectors:	3.5 mm Stereo Headphone output	
	Mono-Microphone input on board	
	Left & Right Speaker Out connectors	
Power connector:	5V DC-Jack, 2.0mm (Power supply: DC5V/3.5A, 2.1mmX5.5mm)	
Debug connectors:	UART to USB connector	
	RJ-45 connector for 10/100 Base-T	
	20-pin Standard JTAG connector	
Sensor	eCOMPASS	
	Accelerometer	
	Gyroscope (unpopulated)	
Camera	CMOS Camera connector	
CAN	CAN bus connector	
Bluetooth	20-pin Bluetooth Connector	
EMV SIM	14-pin EMV SIM connector	
User Interface Buttons	ON/OFF, Reset button	
LED Indicators	Power status, UART	

Table 1. Features (continued)

Coin Cell	Connection point for ML414 Coin Cell (unpopulated) for RTC Operation
Expansion Port	ARDUINO Headers
PCB	Main board: 2.66 inch x 1.27 inch (6.76cm x 4.24 cm), 4-layer board
	Base board: 5.12 inch x 4.25 inch (13.0cm x 10.8 cm), 4-layer board

1.2 i.MX 6UltraLite EVK contents

The i.MX 6UltraLite EVK contains the following items:

- i.MX 6UltraLite Main board & Base board
- Quick Start Guide

1.3 i.MX 6UltraLite EVK board revision history

- Rev A—Proof of Concept
- Rev B—Prototype (Internal Freescale Development)
- Rev C—Production (For Customer)

The board assembly version will be printed on a label, usually attached to the bottom side. The assembly version will be the letter designation following the schematic revision: base board is 700-28616 REV C, main board is 700-28617 REV C.

2 Specifications

This chapter provides detailed information about the electrical design and practical considerations of the EVK board, and is organized to discuss each block in the following block diagram of the EVK board.

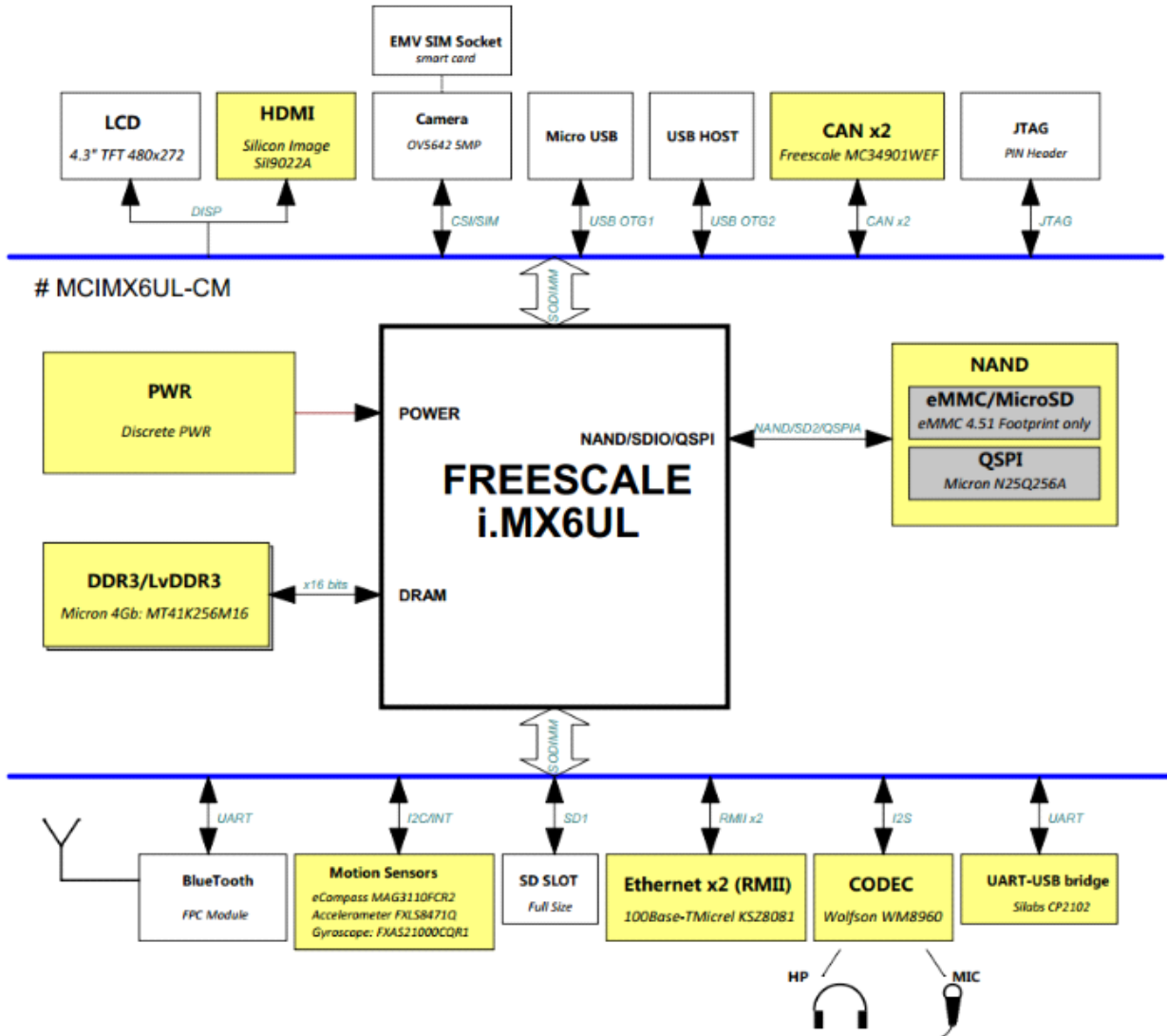

Figure 1. Block diagram

The overview of the i.MX 6UltraLite EVK board is shown in the following figure.

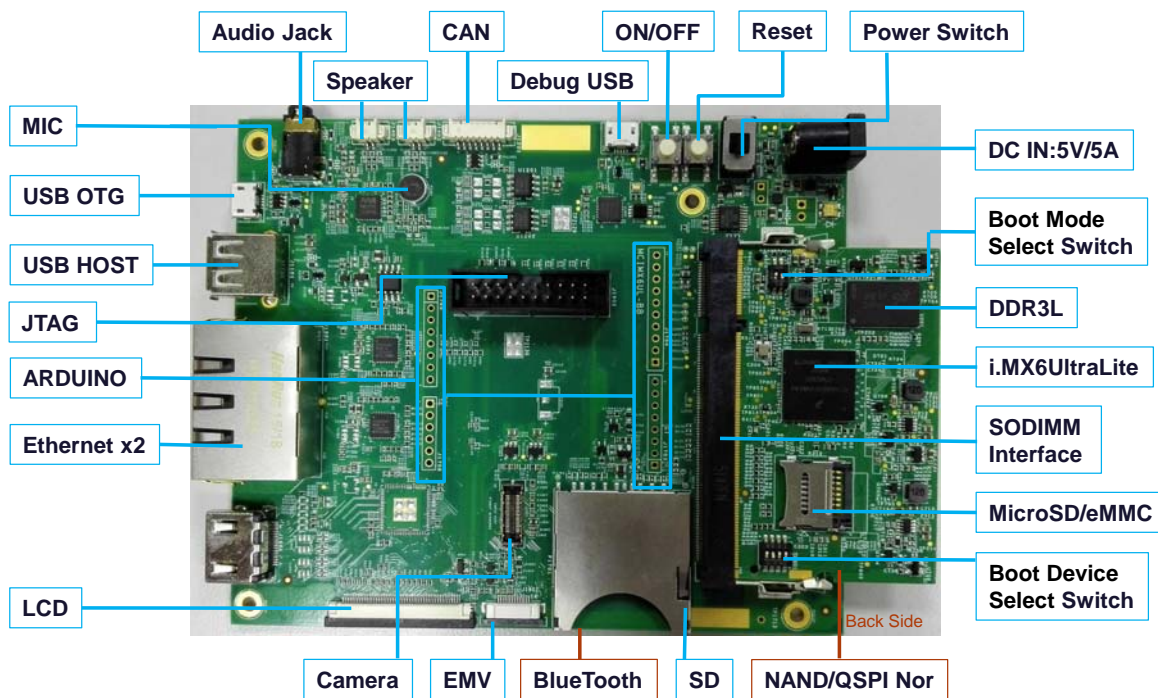

Figure 2. Overview of the i.MX 6UltraLite EVK board



Figure 3. Overview of the i.MX 6UltraLite EVK board connection

2.1 i.MX 6UltraLite processor

The i.MX 6UltraLite processor represents Freescale Semiconductor's latest achievement in integrated multimedia-focused products offering high performance processing with a high degree of functional integration, targeted towards the growing market of connected devices. The i.MX 6UltraLite processor features Freescale's advanced implementation of the single ARM[®]Cortex[®]-A7 core, which operates at speeds up to 528 MHz. The i.MX 6UltraLite includes integrated power management module that reduces the complexity of external power supply and simplifies the power sequencing. Each processor provides a 16-bit DDR3/LVDDR3/LPDDR2 memory interface and a number of other interfaces for connecting peripherals, such as WLAN, Bluetooth, GPS, displays, and camera sensors.

The more detail information about the processor can be found in the datasheet and the reference manual, which can be obtained from the Freescale website.

2.2 Boot mode configurations

BOOT_MODE[1:0] are used to select system boot mode. On the i.MX 6UltraLite EVK board, a dual-switch (SW602) is used to select the input voltage of these two pins, either 0 or 3.3V.

Table 2. SW602 boot mode pin settings

D1/MODE1	D2/MODE0	Boot Mode
OFF	OFF	Boot From Fuses
OFF	ON	Serial Downloader
ON	OFF	Internal Boot
ON	ON	Reserved

**Figure 4. SW602 boot mode settings**

Typically, internal boot is selected for normal boot, which is configured by external BOOT_CFG GPIOs. Then the developer must set the switch SW602: D2(MODE0) to OFF, D1(MODE1) to ON, and use SW601 to select the boot device. This is shown in the following table and figure.

Table 3. SW601 boot device settings

D1	D2	D3	D4	Boot Device
OFF	OFF	ON	OFF	MicroSD
OFF	OFF	OFF	OFF	QSPI
OFF	ON	ON	OFF	EMMC
ON	ON	OFF	ON	NAND

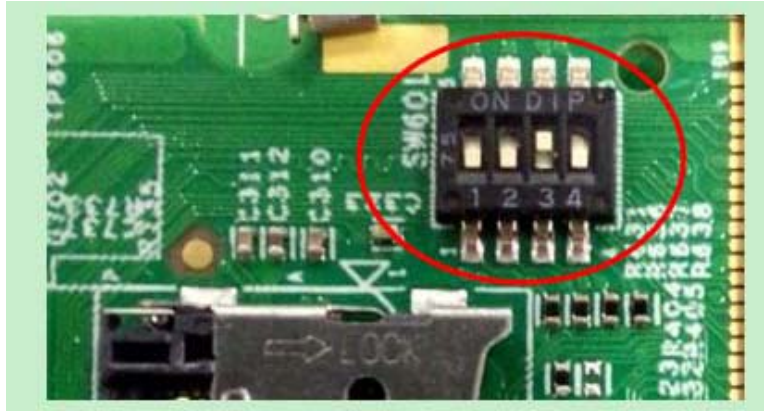

Figure 5. SW601 boot device settings

On the i.MX 6UltraLite EVK board, the default boot device is USDHC interface. There are two SD slots on the board, one MicroSD (USDHC-2) on the Main board, one standard SD (USDHC-1) on the Base board, MicroSD (USDHC-2) is the default boot device. If the developer wants to boot from the SD (USDHC-1) by default, need to remove R613 (10K) and install R642 (10K). The location of the R613 and R642 is on the bottom side as show in the following figure.

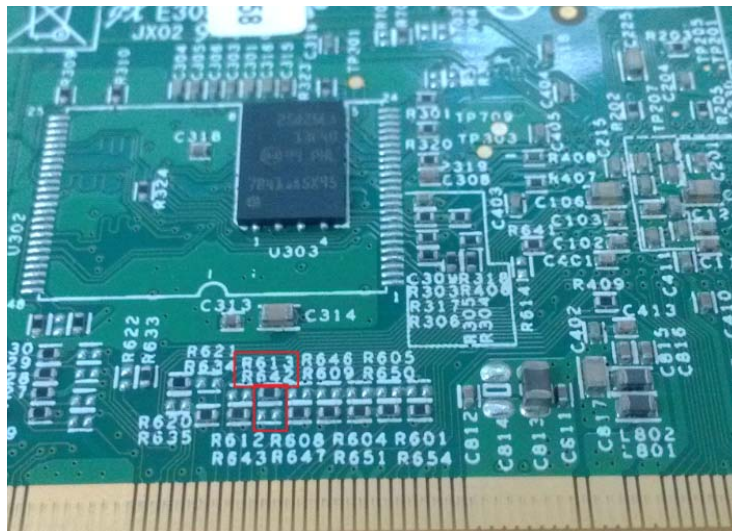

Figure 6. Location of the R613 and R642

NOTE

For more information about boot mode configuration, see the System Boot chapter of the i.MX 6UltraLite Reference Manual.

For more information about i.MX 6UltraLite EVK boot device selection and configuration, see the main board schematic.

2.3 Power tree

A DC5V/3.5A external power supply with a 2.1 mm x 5.5 mm plug is used to supply the i.MX 6UltraLite EVK board at connector J2001, and a slide switch SW2001 is used to turn the power ON/OFF. There is an

over-voltage protection circuit at the input power rail, so if the output voltage of the power supply exceeds 5.6V, the circuit will shut the system down. Discrete regulators are used to generate different power rails for the whole system.

The power tree is shown in the following figure.

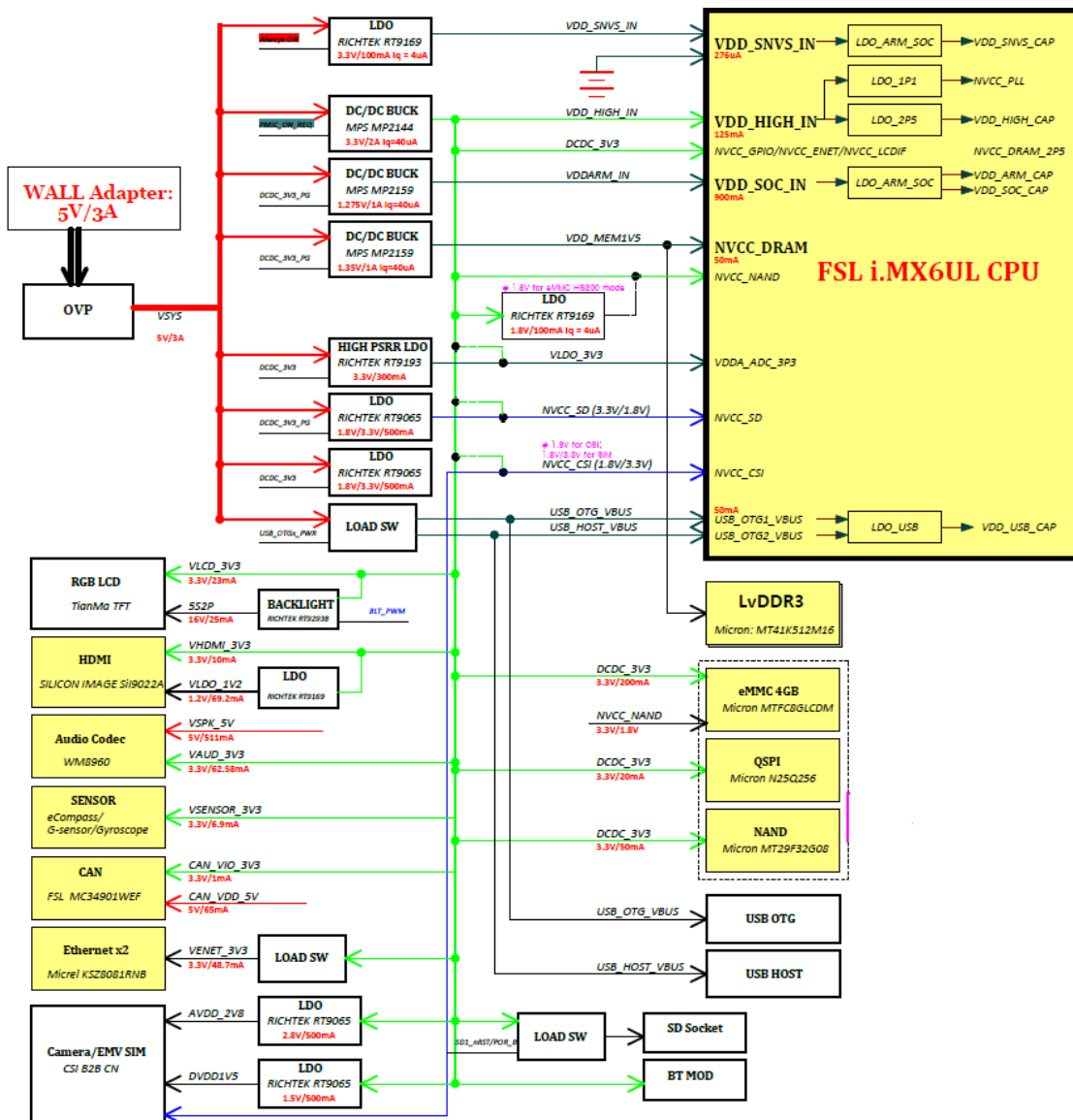

Figure 7. Power tree

The power tree displays all of the power supply rails used on the EVK board.

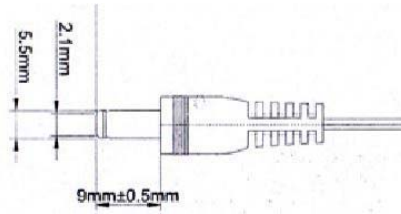

Figure 8. Plug size for DC5V power supply

The power control logic of the i.MX 6UltraLite EVK board is shown in the following figure.

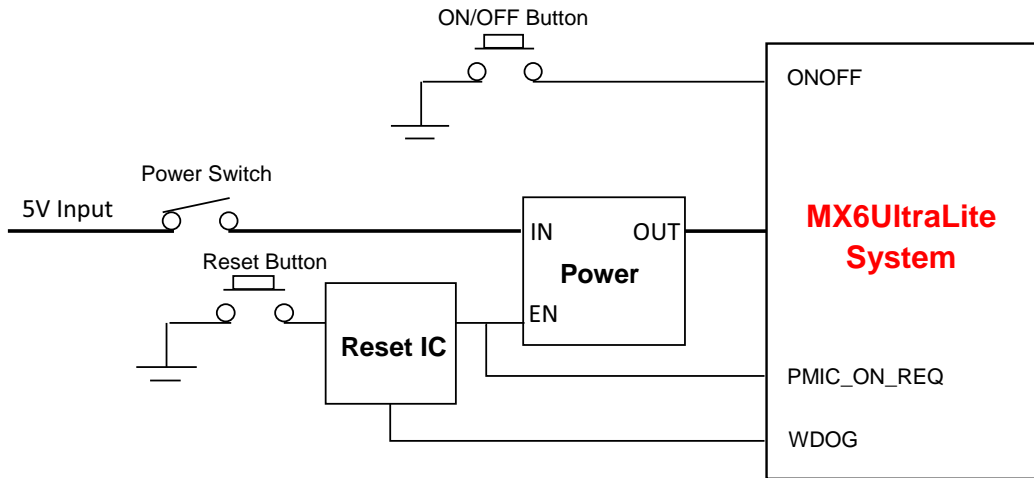

Figure 9. Power Control Diagram

The power rails on the board are shown in the following table.

Table 4. Power rails

Regulator	Voltage /max-current	Power domains	Modules
DC/DC BUCK MP2159	1.3V / 1A	VDD_ARM_SOC_IN	VDDSOC
DC/DC BUCK MP2159	1.35V / 1A	NVCC_DRAM	NVCC_DRAM DDR3L SDRAM
DC/DC BUCK MP2144	3.3V / 2A	VDD_HIGH_IN DCDC_3V3	VDD_HIGH GPIO ENET module LCD module NAND module QSPI module CAN module Audio module HDMI module Camera module Bluetooth module

Table 4. Power rails (continued)

LDO RT9169	3.3V / 100mA	VDD_SNVS_IN	VDD_SNVS_IN
LDO RT9193	3.3V / 300mA	VLDO_3V3	ADC module
LDO UM1750	1.8V or 3.3V / 300mA	NVCC_SD	SD module
LDO UM1750	2.8V/300mA	NVCC_CSI	CSI module
LDO UM1750	1.5V/300mA	DVDD_1V5	Camera module
LDO RT9169	1.2V/100mA	VLDO_1V2	HDMI module

2.4 DDR3L DRAM memory

The i.MX 6UltraLite EVK board has one 256 Meg x 16 DDR3L SDRAM (MT41K256M16HA-125:E) for a total of 512 MB RAM memory.

The DDR_VREF is created by a simple voltage divider using 1.5K Ohm 1% resistors and 0.1uF capacitors for stability. The relatively small value resistors provide enough current to maintain a steady midpoint voltage. The calibration resistors used by the DDR3L chips and the processor are 240 Ohm 1% resistors. These resistor values are specified by the DDR3L specifications.

2.5 SD card slots (J301, P1701)

There are two SD card connectors (J301, P1701) on the i.MX 6UltraLite EVK board.

- J301 on the i.MX 6UltraLite EVK Main board is the Micro SD slot for USDHC2 interface.
- P1701 on the i.MX 6UltraLite EVK base board is a standard SD slot for USDHC1. It can also support accessories such as a WiFi card, etc.

2.6 eMMC

The eMMC interface is connected to USDHC2 of i.MX 6UltraLite. It can support up to eMMC 4.5, but the eMMC device is not populated by default on the EVK board. To boot from eMMC, remove the Micro SD socket and populate the eMMC device, and then change the boot device switch (SW601) settings (OFF, ON, ON, OFF) as shown in [Table 3](#).

Additionally, the developer should adjust the BOOT_CFG settings for specified eMMC device by exchanging the pull up/down resistors. See the main board schematic for more information.

2.7 QSPI Nor flash

On the 6UltraLite EVK board, there is one 256 Mbit QSPI Nor Flash device. If the developer wants to boot from the QSPI flash, he must change the boot device switch (SW601) settings to OFF, OFF, OFF, OFF, as shown in [Table 3](#).

Additionally, the developer should adjust the BOOT_CFG settings for specified QSPI Nor Flash device, by exchanging the pull up/down resistors. See the main board schematic for more information.

2.8 NAND flash

NAND flash is not populated by default on the i.MX 6UltraLite EVK board. If the developer wants to boot from the NAND flash, the following reworks should be implemented:

1. Remove the QSPI Nor flash device
2. Populate the NAND device
3. Change the Boot-mode switch (SW601) settings to ON, ON, OFF, ON
4. Additionally, the developer should adjust the BOOT_CFG settings for specified NAND Flash device, by exchanging the pull up/down resistors. See the main board schematic for more information.

Note that the data lines of NAND flash are multiplexed with the eMMC and MicroSD, so they can't be used at the same time.

2.9 Dual ethernet connector (J1501)

There are two Ethernet MAC controllers in the i.MX 6UltraLite processor. The Ethernet subsystem of the i.MX 6UltraLite EVK board is provided by the MICREL KSZ8081RNB 10/100M Ethernet Transceiver (U1501, U1601) and a dual port RJ45 (J1501) with integrated Magnetic.

The MAC addresses are shown on the sticks upon the RJ45 connector.

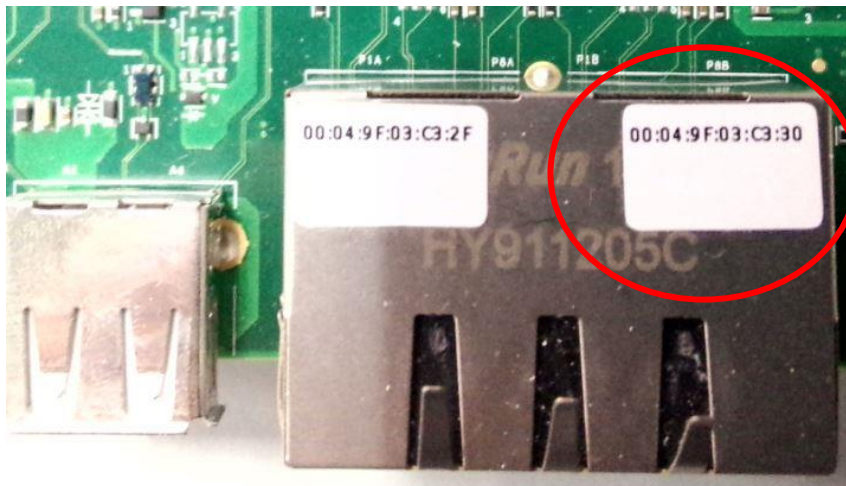

Figure 10. Dual Port RJ45

2.10 USB PHY connector (J1102, J1101)

The i.MX 6UltraLite Applications Processors contains two high speed (HS) USB 2.0 OTG (Up to 480 Mbps) controllers, with two integrated HS USB Phy. On the EVK board, J1101 is a Type-A connector for USB host port, J1102 is a Micro-B connector for USB OTG port. The OTG port J1102 is also used for downloading the boot image by MFGTool in Serial Download Mode.

2.11 Audio input/output connectors (J1401/P1401/J1402 & J1403)

The Audio CODEC used on the i.MX 6UltraLite EVK board is Wolfson's Low Power, high quality Stereo Codec, WM8960. The digital interface between i.MX 6UltraLite and WM8960 includes four signals:

- SYNC_CLK
- BCLK
- DACDAT
- ADCDAT

i.MX 6UltraLite also provides the MCLK to WM8960.

i.MX 6UltraLite EVK includes one headphone interface (J1401), one onboard MIC (P1401), and two speaker interfaces (J1402, J1403). J1401 is a 3.5mm 4-pole (or TRRS) phone jack, which supports jack detect.

2.12 USB debug connector (J1901)

On the EVK board, CP2102, a USB to Serial UART IC is used to convert the UART signal to the USB signal. With the Micro-B USB connector J1901, the connection for debugging is simplified. A Micro-B to standard A USB cable is enough.

UART1 port is used as the default debug port. No RTS or CTS signals are sent from the processor to the debug connector because these signals are commonly ignored by most applications. The required terminal settings are shown in the following table.

Table 5. Terminal settings

Baud rate	115,200
Data bits	8
Parity	None
Stop bits	1
Flow control	None

2.13 Bluetooth Connector (J1701)

On the EVK board, the J1701 is connected to i.MX 6UltraLite UART2 port, and can be used for Bluetooth. Silex Bluetooth module SX-SDCAN-2830BT is recommended. The developer may need to consult Silex for the detailed information of the module. If the developer wants to verify other Bluetooth modules, a convert board might be needed.

NOTE

J1701 is a bottom-contact type connector for BT connection on the Rev. C board. 20PIN/0.5mm pitch same side FFC/FPC should be used to connect with Silex Bluetooth module SX-SDCAN-2830BT, as shown in the following figure.

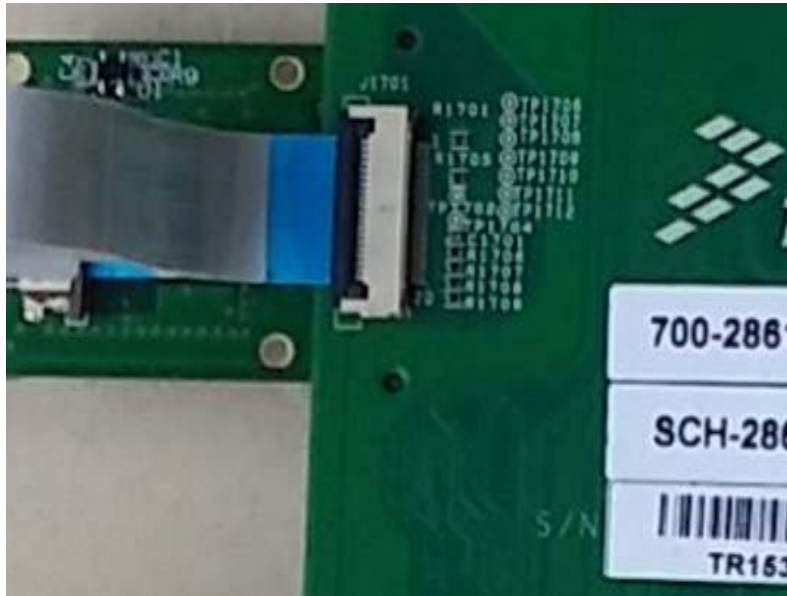
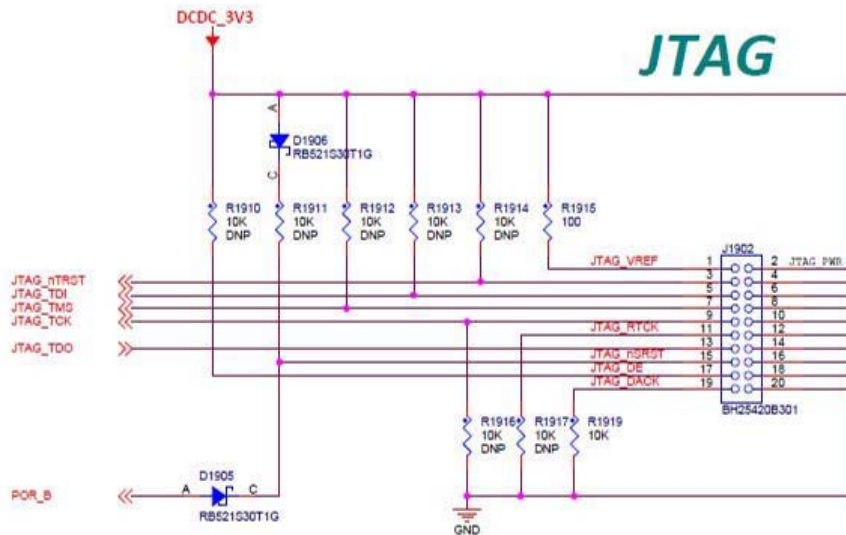

Figure 11. Connect the BT module

2.14 JTAG connector (J1902)

J1902 is a standard 20pin/2.54mm Box Header Connector for JTAG. The pin definitions are shown in following figure.

Figure 12. JTAG pin definitions



NOTE

JTAG is dedicated with Audio CODEC signals. Remove R1407, R1431~R1434 resistors while using JTAG debug.

2.15 ARDUINO expansion port (J1703-J1706)

J1703-J1706 (unpopulated) is defined as the ARDUINO Interface. If the developer wants to use the processor for ARDUINO development, the following rework should be implemented.

- Populate- R1717-R1732

The pin definitions of ARDUINO interface are shown in following table.

Table 6. ARDUINO pin definitions

J1703	J1706
UART_RX/D0	A0
UART_TX/D1	A1
D2	A2
D3	A3
D4	A4
D5	A5
D6	
D7	

J1704	J1704
D8	NC
D9	3.3V
D10/SPI_CS	RESET
D11/SPI_MOSI	3.3V
D12/SPI_MISO	5V
D13/SPI_CLK	GND
GND	GND
3.3V	3.3V
D14/I2C_SDA	
D15/I2C_SCL	

2.16 Camera module connector (J1801)

One parallel CSI (Camera Sensor Interface) (up to 24 bit and up to 133 MHz) is supported by the i.MX 6UltraLite processor. It is designed to support 24-bit RGB888/YUV444, CCIR656, 8-bit YCbCr, YUV or RGB, and 8-bit/10-bit/26-bit Bayer data input.

The CMOS module is OV5640-MRFL-AB0T, which is based on OmniVision chipset OV5640. The developer can choose another CMOS module on their project, if the pin map is compatible. The connector used in i.MX 6UltraLite EVK is FX12B-40P-0.4SV, from HIROSE.

When the developer is using the camera module, attention must be paid to the installation, as shown in the following figure.



Figure 13. Direction of the camera

2.17 User interface switches

There are three user interface switches on the EVK board. Their functionality is as follows.

2.17.1 ON/OFF button (SW2101)

SW2101 is the ON/OFF button for i.MX 6UltraLite EVK board. The function of this button is listed below.

- In Yocto Project, short press and long press will only generate an interrupt, the usage could be defined by upper software.
- Prolonged depress (>5 sec) will force an immediate hardware shutdown.
- If board is in the SHUTDOWN state, short press of the button will restart (boot) the system.
- If board is in the STANDBY state, short press of the button will bring the system out of standby (resume operations, no boot).

2.17.2 Reset button (SW2102)

Press of the button will reset the system and begin a new boot sequence by powering off and repowering almost all the power rails except the VDD_SNVS on the i.MX 6UltraLite EVK board.

2.18 Power switch (SW2001)

SW2001 is a slide switch to control the power of the i.MX 6UltraLite EVK board. The function of this switch is listed below.

- Sliding the switch to the ON position connects the 5V power supply to the Evaluation board main power system.
- Sliding the switch to OFF position immediately removes all power from the board.

2.19 Sensors

The i.MX 6UltraLite EVK board has three sensors: Accelerometer (FXLS8471Q), eCOMPASS (MAG3110), and Gyroscope (FXAS21002CQ, unpopulated). These three sensors are connected to i.MX 6UltraLite I2C1 port.

2.19.1 Accelerometer

FXLS8471Q is a small, low-power, 3-axis, linear accelerometer in a 3 mm x 3 mm x 1 mm QFN package. FXLS8471Q has dynamically selectable acceleration full-scale ranges of ± 2 g/ ± 4 g/ ± 8 g and 14 bits of resolution.

2.19.2 eCOMPASS (U1302)

MAG3110 is a small, low-power, 3-axis digital magnetometer. It works by measuring the strength of a magnetic field, which is a combination of earth's magnetic field and the magnetic fields of nearby objects, including distortions. The device can be used in conjunction with a 3-axis accelerometer to produce orientation-independent, accurate compass heading information.

2.19.3 Gyroscope (U1303)

FXAS21002CQ is a small, low-power, yaw, pitch, and roll angular rate gyroscope with 16-bit ADC resolution. The full-scale range is adjustable from 250/s to 2000/s. It's not populated by default, so if the developer wants to verify this feature, the chip should first be purchased and soldered.

2.20 User interface LED indicators

There are two LED status indicators located on the board. The functions of these LEDs include:

- Main Power Supply (D2003)
 - Green — DC 5V main supply (WALL_5V_DC_JACK) is normal.
 - Red — WALL_5V_DC_JACK is over 5.6V.
 - Off — the board is not powered.
- UART (D1903)
 - Green flashing — Debug UART data are being transmitted to PC.
 - Orange flashing — Debug UART data are being received from PC.

2.21 HDMI display connector (J1001)

The i.MX 6UltraLite EVK board has a HDMI Display interface with Type A connector. The EVK board use a HDMI Transmitter IC SiI9022A from Silicon Image to convert the parallel LCD signals to HDMI signals, but the HDMI device is the chip is not populated by default. If the developer wants to use the HDMI display function, the following reworks should be implemented.

- Populate U1001---SiI9022A
- Populate U1002, U1003, TVS1001~TVS1005
- Populate L1001~L1004, D1002, R1023

In the i.MX 6UltraLite EVK board, parallel LCD signals to SiI9022A are multiplexed with the LCD model, and the SPDIF signal is multiplexed with the JTAG interface, so they can't work at the same time.

2.22 Optional back-up coin cell holder (BT2101)

On the i.MX 6UltraLite EVK board, there is a connector (BT2101) for holding an ML414 Lithium coin cell battery. The coin cell provides an alternative power supply for i.MX 6UltraLite VDD_SNVS_IN power rail when the main VDD_SNVS_3V3 is off. When VDD_SNVS_3V3 is on, then coin cell can be charged through a current limit resistor R101. i.MX 6UltraLite has an internal LDO to regulate the VDD_SNVS_IN power to supply the RTC subsystem. When DC 5V power supply is removed, the coin cell will provide power only to the VDD_SNVS_IN power rail of the EVK board. To increase the keep time of RTC, the developer should optimize the power consumption of the whole VDD_SNVS_IN power rail.

2.23 LCD daughter card

For developers wishing to use LCD, Freescale provides an optional LCD module LCD8000-43T which has a 4.3 inch touch-screen and supports a resolution of up to 480X3(RGB)X272. This module already contains a 50pin FPC cable, which can be inserted to connector J901 on the base board (the bottom contact). The developer can purchase the LCD module from the Freescale website.

3 PCB information

Both the base board and main board are made using standard 4-layer technology. The material used was FR-4.

The PCB stack-up information is shown in the following table.

Table 7. Board stack-up information

Base board				Main board			
Layer	Description	Copper (Oz)	Dielectric Thickness (mil)	Layer	Description	Copper (Oz)	Dielectric Thickness (mil)
1	Signal	1	—	1	Signal	1	—
	Dielectric	—	3.0		Dielectric	—	3
2	GND	1	—	2	GND	1	—
	Dielectric	—	36		Dielectric	—	28
3	Power	1	—	3	Power	1	—
	Dielectric	—	3.0		Dielectric	—	3
4	Signal	1	—	4	Signal	1	—

4 EVK Design Files

The schematics, layout files, and gerber files (including Silkscreen) can be downloaded from the following Web page:

http://www.freescale.com/webapp/sps/site/prod_summary.jsp?code=i.MX6UL

5 Contents of the Evaluation Kit

Table 8. EVK contents

Item	Description
Main Board	CPU board with i.MX 6UltraLite applications processor, memory, discrete powers and microSD card slot
Base Board	Peripherals and connectivity board
Documentation	Quick Start Guide

NOTE

Power supply, USB Cable, microSD card, LCD Module are not standard parts of the Evaluation Kit.

Table 9. Required preparation equipment

Item	Description
Power Supply	Output: 5V/3.5A, Plug: 2.1mmx5.5mm
USB Cable	USB cable (micro-B to standard-A)
MicroSD card	Bootable Linux image
LCD Module (optional)	LCD8000-43T is the recommended module, which has a 4.3 inch resistive touch screen and supports a resolution of up to 480X3(RGB)X272.

6 Revision history

Rev. A is the initial release of this document.

How to Reach Us:

Home Page:
freescale.com

Web Support:
freescale.com/support

Information in this document is provided solely to enable system and software implementers to use Freescale products. There are no express or implied copyright licenses granted hereunder to design or fabricate any integrated circuits based on the information in this document.

Freescale reserves the right to make changes without further notice to any products herein. Freescale makes no warranty, representation, or guarantee regarding the suitability of its products for any particular purpose, nor does Freescale assume any liability arising out of the application or use of any product or circuit, and specifically disclaims any and all liability, including without limitation consequential or incidental damages. "Typical" parameters that may be provided in Freescale data sheets and/or specifications can and do vary in different applications, and actual performance may vary over time. All operating parameters, including "typicals," must be validated for each customer application by customer's technical experts. Freescale does not convey any license under its patent rights nor the rights of others. Freescale sells products pursuant to standard terms and conditions of sale, which can be found at the following address: freescale.com/SalesTermsandConditions.

ARM and ARM Powered are registered trademarks of ARM Limited (or its subsidiaries) in the EU and/or elsewhere. ARM7 is a trademark of ARM Limited (or its subsidiaries) in the EU and/or elsewhere. All rights reserved.

© 2015 Freescale Semiconductor, Inc.

Document Number: IMX6ULEVKHUG
Rev. 0
08/2015





Стандарт Электрон Связь

Мы молодая и активно развивающаяся компания в области поставок электронных компонентов. Мы поставляем электронные компоненты отечественного и импортного производства напрямую от производителей и с крупнейших складов мира.

Благодаря сотрудничеству с мировыми поставщиками мы осуществляем комплексные и плановые поставки широчайшего спектра электронных компонентов.

Собственная эффективная логистика и склад в обеспечивает надежную поставку продукции в точно указанные сроки по всей России.

Мы осуществляем техническую поддержку нашим клиентам и предпродажную проверку качества продукции. На все поставляемые продукты мы предоставляем гарантию .

Осуществляем поставки продукции под контролем ВП МО РФ на предприятия военно-промышленного комплекса России , а также работаем в рамках 275 ФЗ с открытием отдельных счетов в уполномоченном банке. Система менеджмента качества компании соответствует требованиям ГОСТ ISO 9001.

Минимальные сроки поставки, гибкие цены, неограниченный ассортимент и индивидуальный подход к клиентам являются основой для выстраивания долгосрочного и эффективного сотрудничества с предприятиями радиоэлектронной промышленности, предприятиями ВПК и научно-исследовательскими институтами России.

С нами вы становитесь еще успешнее!

Наши контакты:

Телефон: +7 812 627 14 35

Электронная почта: sales@st-electron.ru

Адрес: 198099, Санкт-Петербург,
Промышленная ул, дом № 19, литера Н,
помещение 100-Н Офис 331