

P4080 Development System User's Guide

by *Networking and Multimedia Group*
Freescale Semiconductor, Inc.
Austin, TX

1 Overview

The P4080 development system (DS) is a high-performance computing, evaluation, and development platform supporting the P4080 Power Architecture® processor. The P4080 development system's official designation is P4080DS, and may be ordered using this part number.

The P4080DS is designed to the ATX form-factor standard, allowing it to be used in 2U rack-mount chassis, as well as in a standard ATX chassis. The system is lead-free and RoHS-compliant.

Contents

1. Overview	1
2. Features Summary	2
3. Block Diagram and Placement	4
4. Evaluation Support	6
5. Architecture	8
6. Configuration	40
7. Programming Model	45
8. Revision History	58
A. References	58

2 Features Summary

The features of the P4080DS development board are as follows:

- Support for the P4080 processor
 - Core processors
 - Eight e500mc cores
 - 45 nm SOI process technology
 - High-speed serial port (SerDes)
 - Eighteen lanes, dividable into many combinations
 - Five controllers support five add-in card slots.
 - Supports PCI Express, SGMII, Nexus/Aurora debug, XAUI, and Serial RapidIO®.
 - Dual DDR memory controllers
 - Designed for DDR3 support
 - One-per-channel 240-pin sockets that support standard JEDEC DIMMs
 - Triple-speed Ethernet/ USB controller
 - One 10/100/1G port uses on-board VSC8244 PHY in RGMII mode.
 - One USB ULPI
 - Combo USB/RJ45 stack
 - Local bus
 - 128-Mbyte NOR Flash (fast boot)
 - PromJet debug port
 - eSDHC
 - Connects to SDMedia card slot for boot code or mass storage
 - SPI
 - 16-Mbyte EEPROM device for boot code and storage
 - I²C
 - Three controllers
 - I²C-based, real-time clock and battery-backed SRAM
 - EEPROM storage for boot-sequencer, SystemID, ngPIXIS(FPGA) processor code, and so on
 - UART
 - Two serial ports at up to 115200 Kbps
 - Debug features
 - Both Legacy COP/JTAG and Aurora/Nexus debug support
 - EVT support
 - Package
 - 1295-pin, 1 mm pitch BGA
 - Socket and solder attach can be supported.

- System Logic ngPIXIS(FPGA)
 - Manages system reset sequencing
 - Manages system and SerDes clock speed selections
 - Implements registers for system control and monitoring
 - Manages boot and RCW source selection
 - Internal 8-bit MCU allows independent VCore/temperature monitoring and reconfiguration.
- Clocks
 - System clock
 - SYSCLK switch settable to one of eight common settings in the interval 66 MHz–133 MHz.
 - Software settable in 1-MHz increments from 1–200 MHz.
 - SerDes clock
 - Supports three domains
 - 100-MHz, 125-MHz and 156.25-MHz configurations to support PCI Express, SGMII and XAUI
- Power supplies
 - Three dedicated programmable regulators supplying two cores and platform power pools
 - PMBus control
 - GVDD (DDR power) and VTT/VREF adjustable for DDR3
 - 2.5-V power for Ethernet PHY

3 Block Diagram and Placement

This figure shows the major functions of the P4080DS.

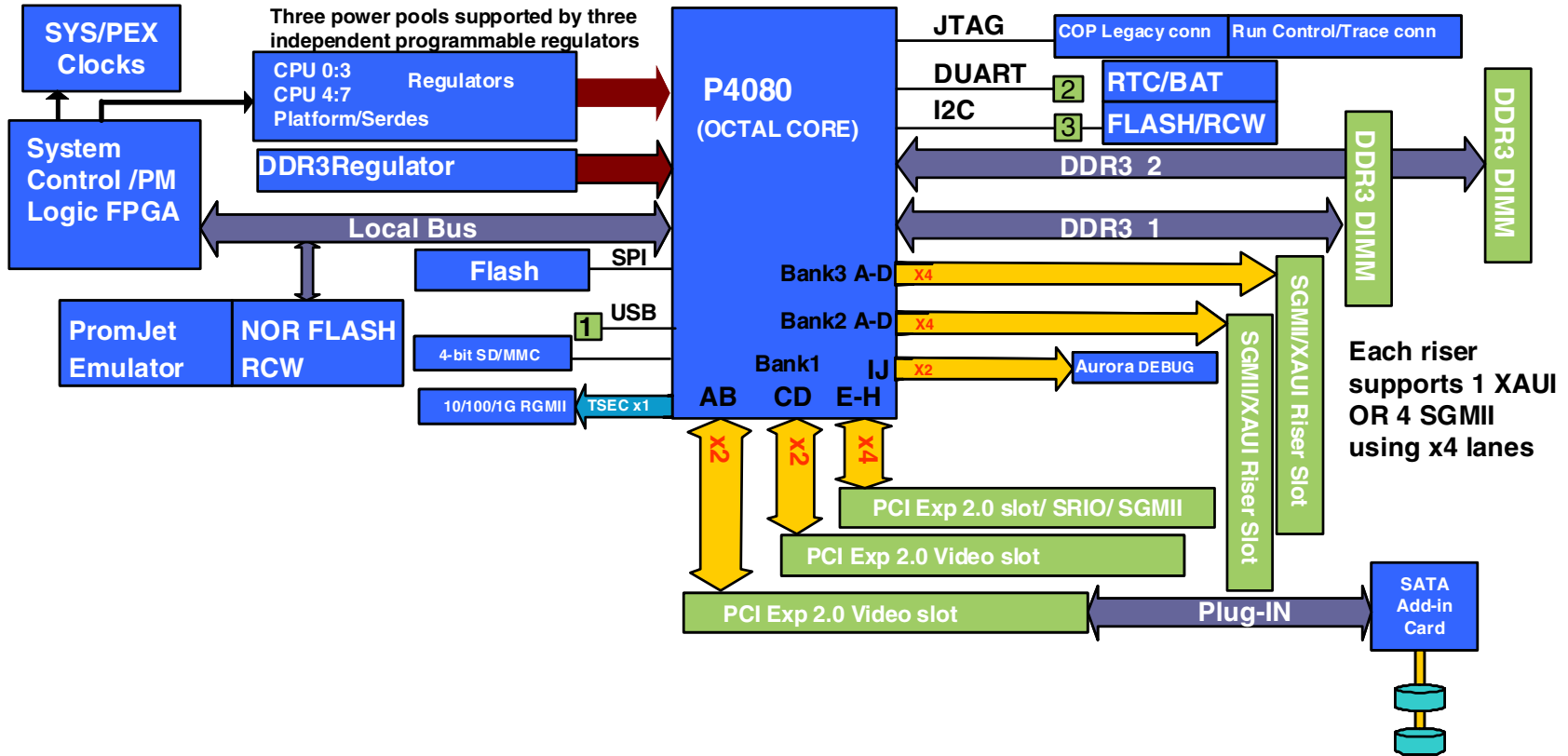
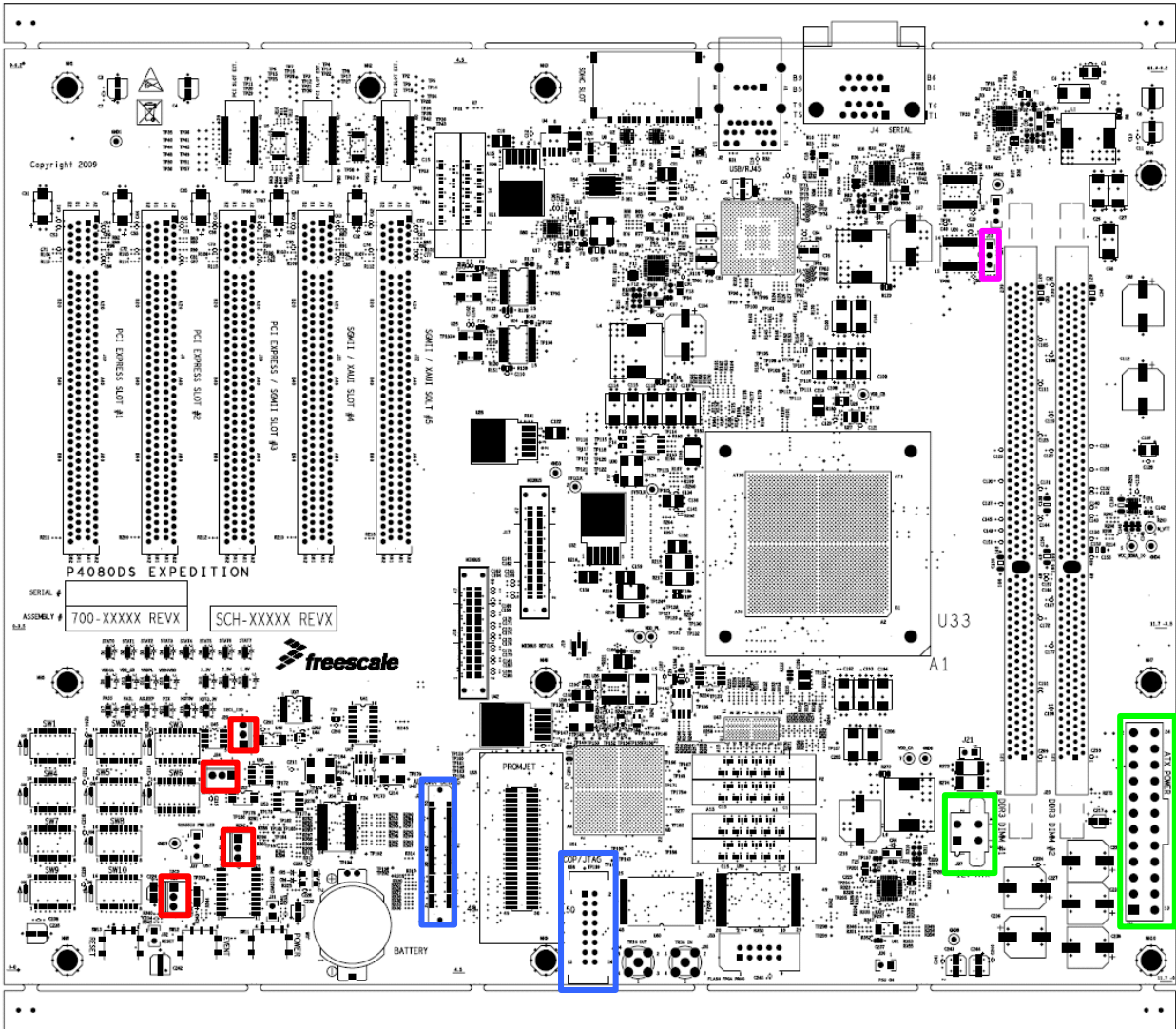

Figure 1. Block Diagram

This figure highlights more difficult-to-find connections that are commonly used.



- Notes:
- I2C HEADERS
 - AURORA and LEGACY COP CONNECTORS
 - ATX POWER CONNECTORS
 - CPU FAN HEADER

Figure 2. Expedition Top View

4 Evaluation Support

The P4080DS is intended to evaluate as many features of the P4080 as are reasonable within a limited amount of board space and cost limitations. This table shows an evaluation of the P4080DS.

Table 1. P4080DS Evaluation Summary

P4080 Feature	Evaluation Support/Methods
SerDes	<ul style="list-style-type: none"> Connects to PCI Express slots for use with graphics or other PEX cards Testable via PCI Express card (typically graphics) or Catalyst™ PCI Express control/monitoring card Traffic monitoring via Tek/Agilent passive mid-point probing
Memory Controller DDR3	<ul style="list-style-type: none"> Combined GVDD (VIO), VTT and MVREF supplies Debugging uses Tek/NextWave analyzer breakout cards. No special MECC/debug tap
eSDHC	Supports SDMedia cards and MMC cards
SPI	Supports standard and x4 devices
Local Bus	<ul style="list-style-type: none"> 1 bank of 16-bit, 8-Mbyte–1-Gbyte Flash (64 Mbytes by default) Option for PromJet access System controller (ngPIXIS) registers implementing the following: board ID, VDD control, frequency reset, self-reset reset, and so on
Serial	<ul style="list-style-type: none"> UART supports two 4-wire serial ports.
I ² C	I ² C bus #1 for the following: <ul style="list-style-type: none"> Boot initialization code System EEPROM (MAC address storage, serial number, and so on) PMBus power regulator control
	I ² C bus #2 for the following: <ul style="list-style-type: none"> DDR bus DIMM module SPD EEPROMs PCI/PCI Express slots (as “SMBus”) ngPIXIS access
Clocking	<ul style="list-style-type: none"> Digitally settable SYSCLK and DDRCLK clock generator Switch-selectable coarse settings Software-selectable fine settings
	<ul style="list-style-type: none"> SerDes reference clocks to SerDes on P4080, NVidia, and slots
	<ul style="list-style-type: none"> Reference clock
GPIO	<ul style="list-style-type: none"> All GPIO attached to test 0.1” header Some GPIO have predefined board functions that can be eliminated.
DMA	Controlled and executable by ngPIXIS logic.
IRQs	EVENT switch normally asserts IRQ* but can drive SRESET0, and/or SRESET1 via software setting.
Power	<ul style="list-style-type: none"> VDD (VCORE+VDD) VID switch-settable ngPIXIS software-monitored/controlled voltages

4.1 Development System Use

For general hardware and/or software development and evaluation purposes, the P4080DS can be used just like an ordinary desktop computer. In the absence of special hardware or software configuration, the P4080DS operates identically to a development/evaluation system such as ArgoNavis(8641DS) or other

members the HPC family. This figure shows an example of the P4080DS system in a desktop configuration.

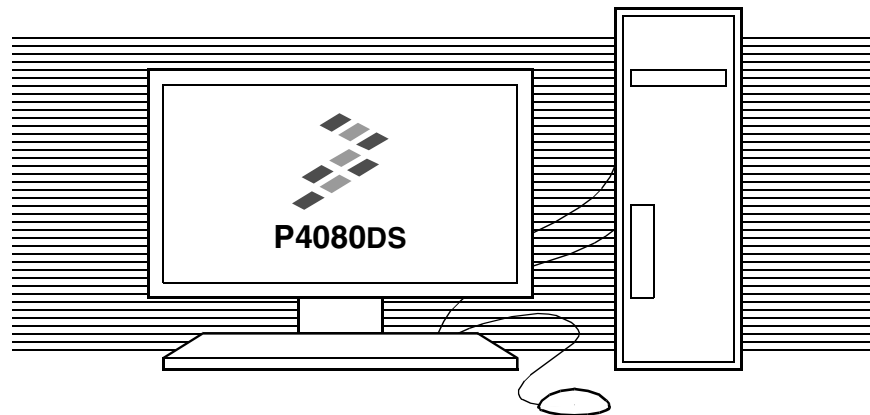

Figure 3. P4080DS Desktop Configuration

4.2 Rackmount Server Use

For use in a rackmount chassis, the P4080DS requires the following modifications:

- Low-profile heatsink
- Non-socketed board

Otherwise, it is similar to the desktop case.

4.3 Embedded Use

For general embedded hardware and/or software development and evaluation purposes, the P4080DS can be used just like an ordinary desktop computer. Peripherals and embedded storage can be connected to the PromJet superser connector.

The ngPIXIS FPGA is used to provide startup configuration information for DINK, UBOOT or Linux and other advanced features are used or ignored.

4.4 AVP-Controlled Evaluation

For many test situations, it is desirable to download a test vector program and run the results. The P4080DS can do this by using a PCI-based control card, such as the DataBlizzard, or a PCI Express-based control

card, such as Freescale’s Komodo card, either stand-alone or in coordination with the ngPIXIS. This table lists an overview example of the steps required to accomplish this.

Table 2. AVP Execution Steps

Step	Details	
Assert Target Reset	Set target reset Target processor (not the system) is reset.	Control card asserts “flying lead” reset line; alternately, the ngPIXIS register bit PX_RST[RSTL] is set to ‘0’.
Setup New Target Environment	Set target core VDD Set requested SYSCLK	VCTL[VCORE]=1 VCORE=xxxxxxx VCTL[SYSCLK]=1 VSPEED[SYS]=xxx
Restart Target	Set target reconfiguration System is reconfigured, target processor remains in reset. This may take several milliseconds.	VCTL[GO]=1
Download Target	Download to target execution space. Presumably the DDR and PCIExpress resources were configured by the I ² C sequencer. If so, a PCIMaster such as the DataBlizzard can simply write test code to system memory via PCI->DDR path.	
Release Target Reset	Release target reset Target processor executes code.	Control card deasserted “flying lead” reset line; alternately the ngPIXIS register bit PX_RST[RSTL] is set to ‘1’.
Collect Results	Results can be extracted from system DDR, PCI Express graphics memory (used as a buffer), or other memory (SDMedia, Flash, PromJet).	

5 Architecture

The P4080DS architecture is primarily determined by the P4080 processor, and by the need to provide “typical,” OS-dependent resources (disk, Ethernet, and so on).

5.1 Processor

This table lists the major pin groupings of the P4080.

Table 3. P4080 Pin Groupings Summary

Signal Group	Details
Memory Controllers	Section 5.1.1, “DDR”
SerDes x18	Section 5.1.2, “SerDes x18”
Ethernet	Section 5.1.3, “Ethernet (EC)”
IEEE 1588	Section 5.1.4, “Support for IEEE Std 1588™ Protocol”
Local Bus	Section 5.1.5, “Local Bus”
eSDHC	Section 5.1.6, “eSDHC”
SPI	Section 5.1.7, “SPI Interface”
USB	Section 5.1.8, “USB Interface”
DMA	Section 5.1.9, “DMA Controller”

Table 3. P4080 Pin Groupings Summary (continued)

Signal Group	Details
eOpenPIC	Section 5.1.10, "eOpenPIC Interrupt Controller"
GPIO	Section 5.1.11, "GPIO Controller Port"
System Control	Section 5.1.12, "Control Group"
UART	Section 5.1.13, "UART Serial Ports"
I2C	Section 5.1.14, "I²C"
EM1 and EM2 Management	Section 5.1.15, "EM1 and EM2 Management Busses"
Debug/Power Management	Section 5.1.16, "Debug and Power Management"
Clock	Section 5.1.17, "Clock"
Thermal	Section 5.1.18, "Temperature"
Power	Section 5.1.19, "Power"

5.1.1 DDR

The P4080 supports DDR2 and DDR3 devices; however, the P4080DS supports only DDR3, using industry-standard JEDEC DDR3 2-rank and 4-rank DIMM modules. However, the system is shipped and supported by software to support UDIMM 2-rank modules for targeted vendors. The type and vendor may change as memory availability varies. The memory interface includes all the necessary termination and I/O power, and is routed so as to achieve maximum performance on the memory bus.

This figure shows the general DDR memory architecture per controller.

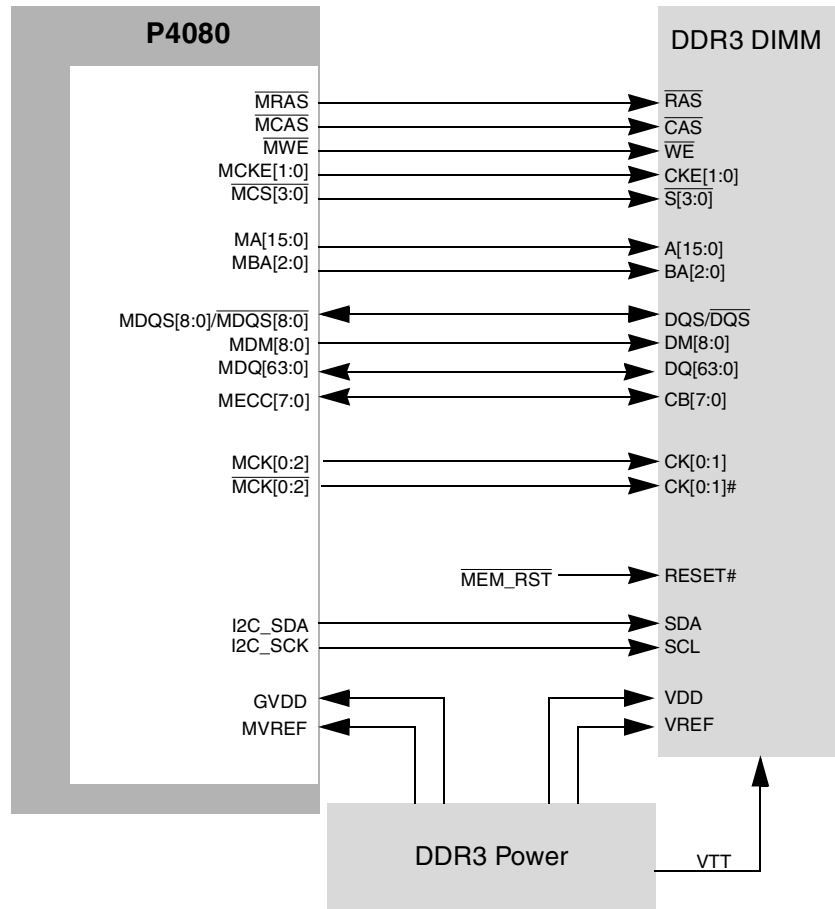

Figure 4. P4080DS Memory Architecture per controller

Note that the P4080DS does not directly support the use of the MECC pins to access internal debug information, because the P4080DS does not provide the special multiplexer, and thus has a simpler routing and signal integrity status. On the other hand, the P4080DS does not interfere with this path, so access to debug information on the MECC pins is possible with the use of a NextWave (or equivalent) DDR logic analyzer connector and the use of non-ECC DDR modules.

32-bit DDR3 interface mode is supported; from the viewpoint of the P4080DS board, the unused lower MDQ/MDS/MDM signals are simply inactive.

The DDR3 power supplies the following interface voltages:

- VDD_IO up to 20 W (10 A at 1.5 V nominal)
- VDDQ+VTT up to 2 A
- MVREF up to 10 mA

5.1.1.1 Compatible DDR-3 Modules

The DDR interface of the P4080DS and the P4080 works with any JEDEC-compliant, 240-pin, DDR3 DIMM module. This table shows several DIMM modules that are believed to be compatible.

Table 4. DDR-3 Modules

Mfg.	Part Number	Size	Ranks	ECC	Data Rate	Verified?	Notes
Elpida	EBJ21EE8BAFA-DJ-E	2 Gbytes	2	Y	1333	TBD	Or later revisions

5.1.2 SerDes x18

The SerDes block provides high-speed serial communications interfaces for several internal devices. The SerDes block provides 18 serial lanes that may be partitioned as shown in this table.

Table 5. SerDes Lane Multiplexing/Configuration

Bank 1										Bank 2				Bank 3			
A	B	C	D	E	F	G	H	I	J	A	B	C	D	A	B	C	D
0	1	2	3	4	5	6	7	8	9	10	11	12	13	14	14	16	17
SLOT 1		SLOT 2		SLOT 3			Aurora Conn.		SLOT 4			SLOT 5					
PCle1 (5/2.5G)		PCle3 (5/2.5G)		PCle2 (5/2.5G)			Debug (5/2.5G)		4x SGMII FM2			4x SGMII FM1					
PCle1 (5/2.5G)		PCle3 (5/2.5G)		PCle2 (5/2.5G)			Debug (5/2.5G)		XAUI FM2			4x SGMII FM1					
PCle1 (5/2.5G)		PCle3 (5/2.5G)		PCle2 (5/2.5G)			Debug (5/2.5G)		XAUI FM2			XAUI FM1					
PCle1 (2.5G)		PCle3 (2.5G)		4x SGMII FM2			Debug (2.5G)		XAUI FM2			4x SGMII FM1					
PCle1 (5/2.5G)		PCle3 (5/2.5G)		—	sRIO2 (2.5G)	—	sRIO1 (2.5G)	Debug (5/2.5G)		4x SGMII FM2			4x SGMII FM1				
PCle1 (5/2.5G)		PCle3 (5/2.5G)		—	sRIO2 (2.5G)	—	sRIO1 (2.5G)	Debug (5/2.5G)		XAUI FM2			4x SGMII FM1				
PCle1 (5/2.5G)		PCle3 (5/2.5G)		—	sRIO2 (2.5G)	—	sRIO1 (2.5G)	Debug (5/2.5G)		XAUI FM2			XAUI FM1				

Note that the term ‘lane’ is used to describe the minimum number of signals needed to create a bidirectional communications channel; in the case of PCI Express or Serial RapidIO, a lane consists of two differential pairs, one for receive and one for transmit, or four in all.

Table 5, top down, shows three clocking banks: 1, 2, and 3. For Bank1, lanes A–B go to slot 1, C–D to slot 2, E–H go to slot 3, and I–J to the Aurora debug connector. For Bank 2, lanes A–D go to slot 4. For Bank 3, lanes A–D got to slot 5.

This figure shows an overview of Bank1.

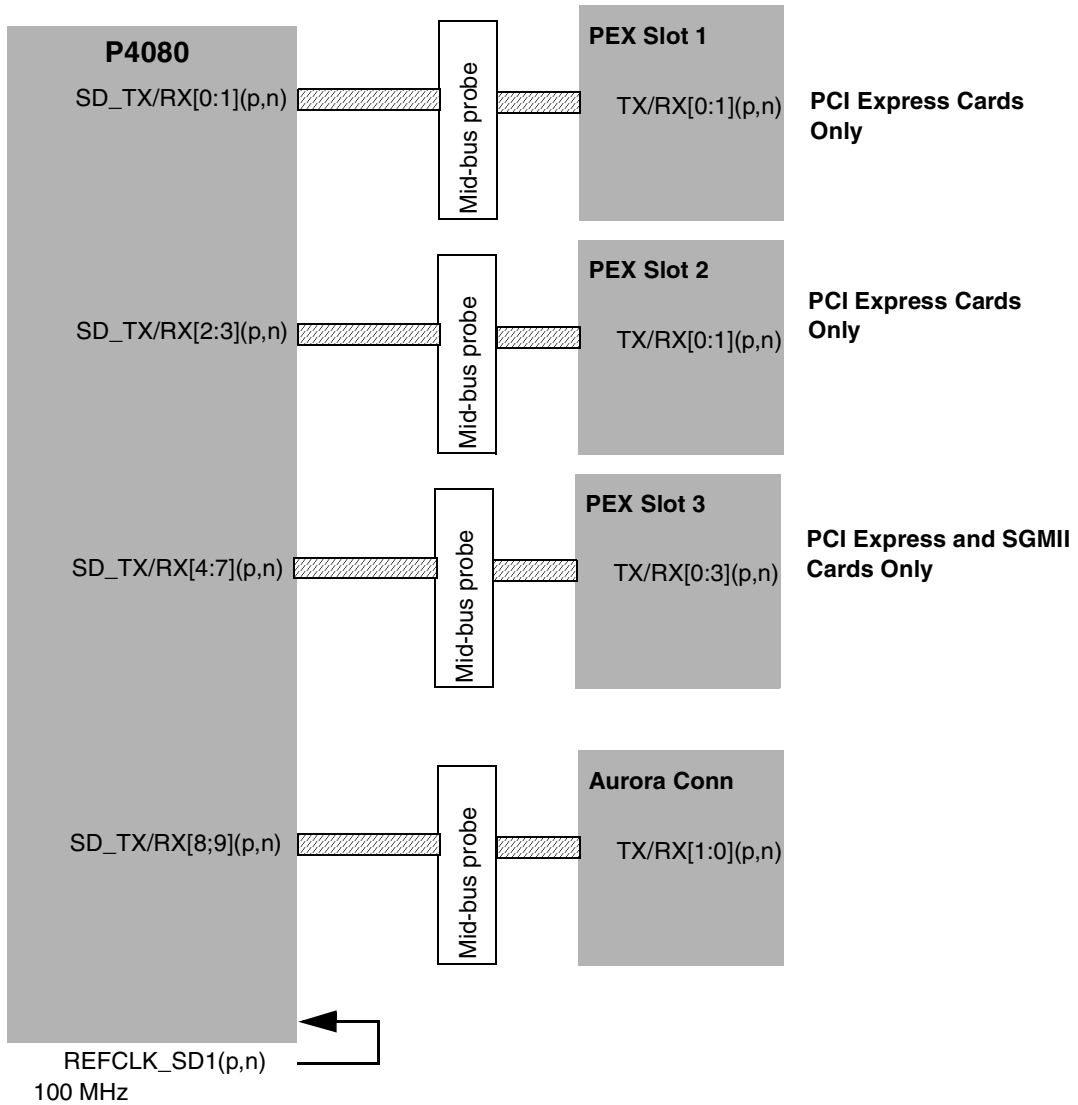

Figure 5. SerDes Bank1 Configuration

Note that a Mid-bus probe can be used with a logic analyzer to analyze bus activity.

This figure shows an overview of SerDes bank 2 and 3.

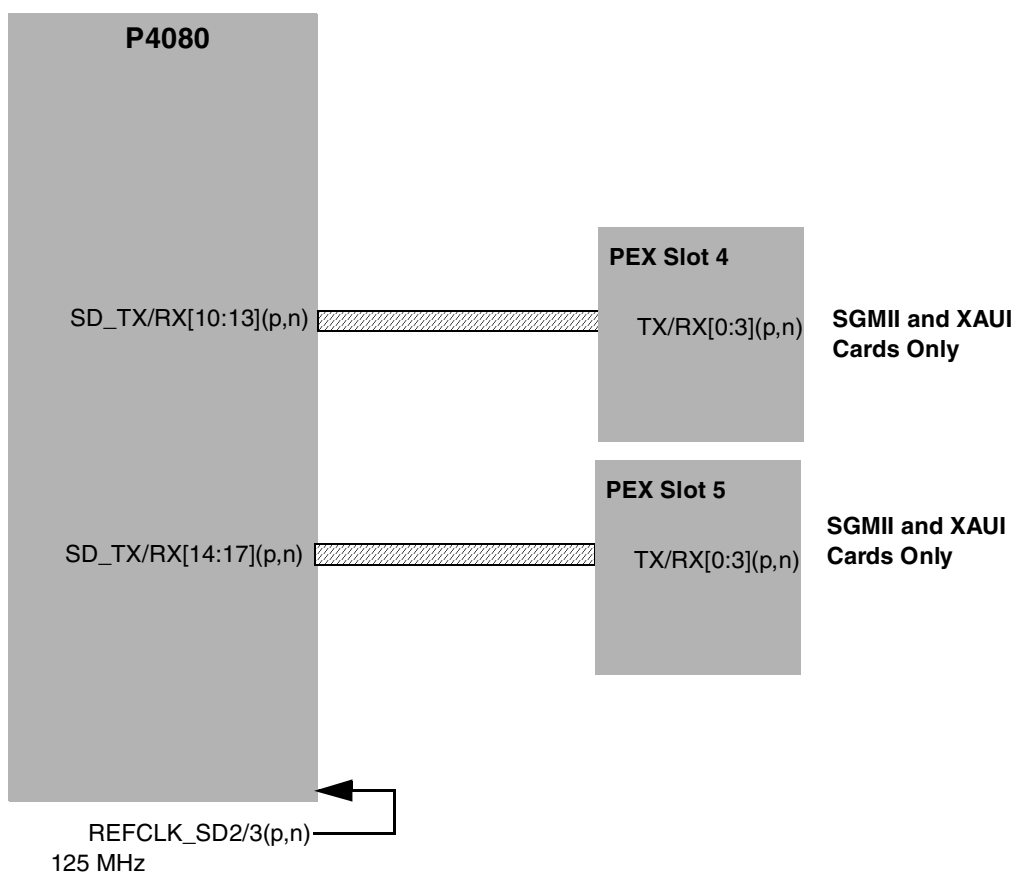

Figure 6. SerDes Bank 2 and 3 Configuration.

Note that the Mid-bus probes are not on the development system, but are available on the SGMII and XAUI riser cards. The SD2 and SD3 clocking domains are separate clock generators.

5.1.3 Ethernet (EC)

The P4080 supports up to two 10/100/1000baseT triple-speed Ethernet controllers (EC). The P4080DS uses one of these, which is channel EC2, and is connected to the on-board Vitesse VSC8244 PHY (the remaining ports are unused) using the RGMII protocol. Alternately, both ECs may be independently connected to a ULPI USB interface; for the P4080DS, EC1 routes via ULPI to a USB PHY. See [Section 5.1.8, “USB Interface,”](#) for more information.

This table summarizes connections and routing.

Table 6. Ethernet Port Locations

P4080 EC #	Connection Port	PHY Address	Location	Notes
2	EC	0	Top port of stack	—
1	USB	na	Bottom port of stack	—

This figure shows the general organization of the Ethernet system.

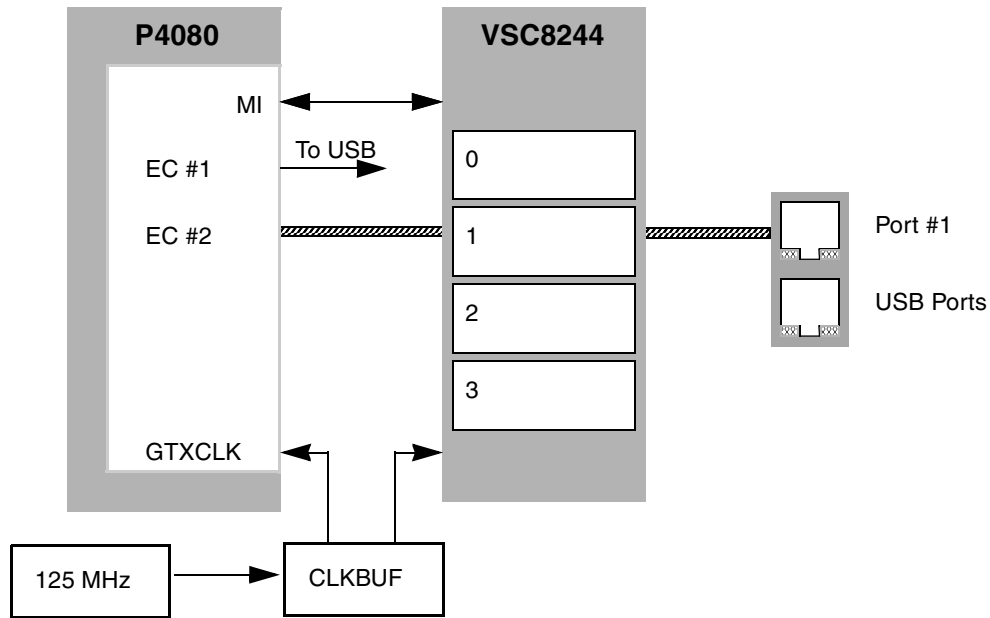

Figure 7. Ethernet Architecture

The P4080DS uses the ICS8304AMLF to drive the Ethernet GTX clocks with the correct edge rate at 2.5 V.

See the Vitesse website for programming information for the VSC8244 PHY.

5.1.4 Support for IEEE Std 1588™ Protocol

The P4080 includes support for the IEEE 1588 precision time protocol (PTP). This facility works in tandem with the Ethernet controller to time-stamp incoming packets.

This figure shows an overview of the IEEE 1588 block.

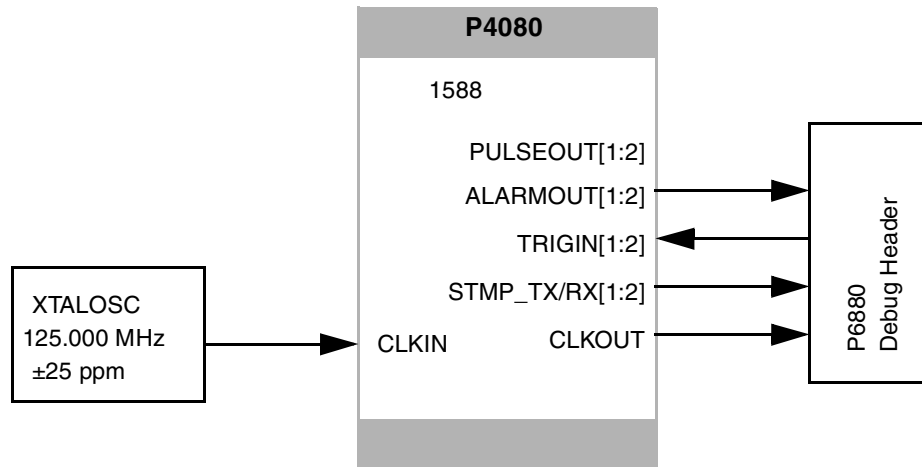

Figure 8. IEEE-1588 Interface Overview

5.1.5 Local Bus

For the P4080DS, the enhanced local bus controller (eLBC) connects to various Flash devices and the ngPIXIS FPGA internal register space. The P4080 only supports 16-bit devices, so the eLBC interface is comparatively simpler than past development systems. In particular, a single 16-bit latch/buffer is used to both latch the portion of the address that is not already provided by the latched address pins and to buffer the data. This figure shows an overview of the eLBC.

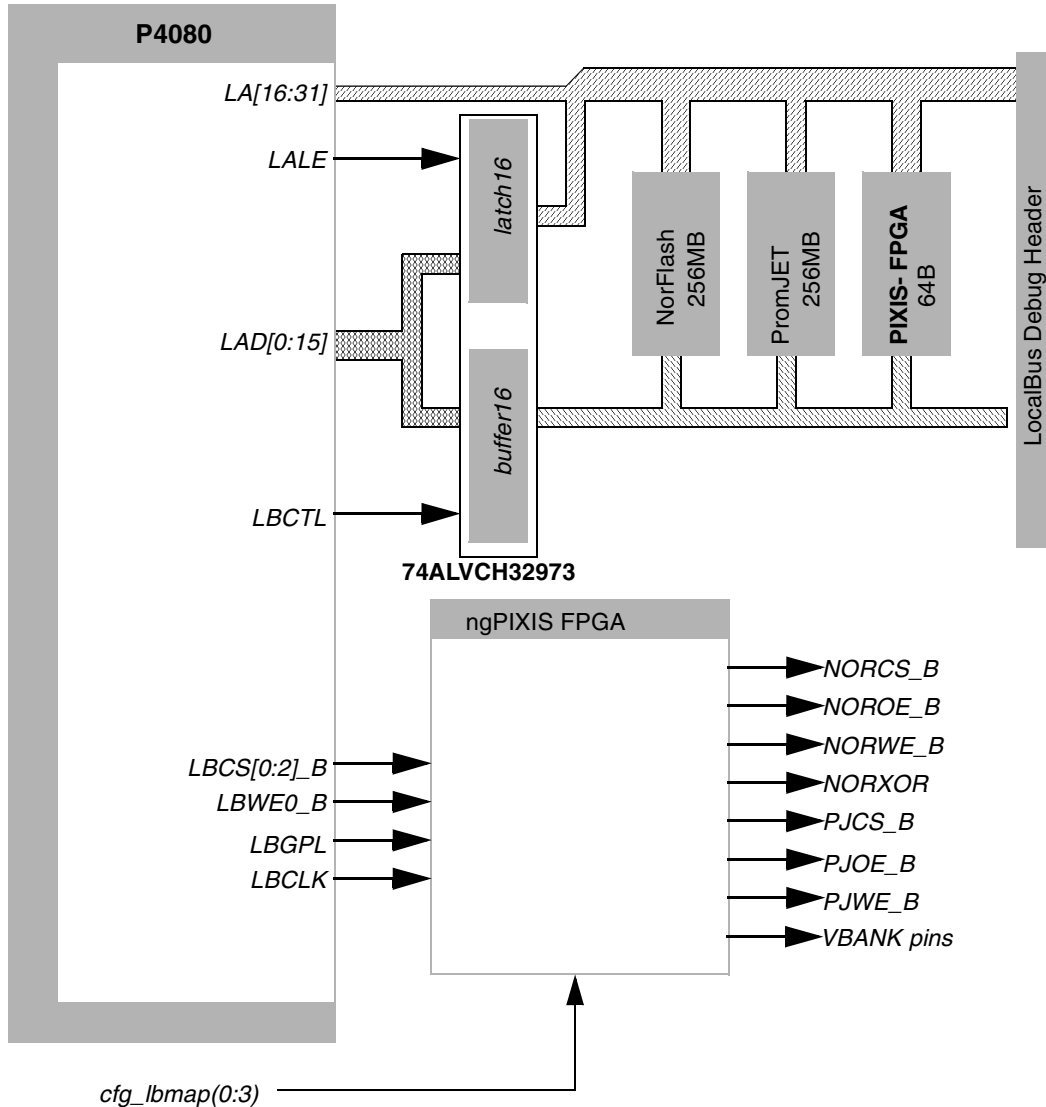

Figure 9. Local Bus Overview

The P4080 can redirect boot fetches to the eLBC, where it is routed to the device attached to $\overline{\text{LCS0}}$. To support greater flexibility, the ngPIXIS can re-route the $\overline{\text{LCS0}}$ pin to other devices, allowing the P4080DS to boot from the following devices:

- NORFlash
- NORFlash with MSB[0:1] address lines XOR'd (virtual bank swapping)

- PromJet

Local bus chip select routing is summarized in this table. The “cfg_lbmap” column is used to rearrange the internal addresses of NOR Flash devices, based on user configuration options. Simplistically, no matter what state the switches are in, the end-user toggling the switch results in toggling the halves or quarters of the NOR Flash and toggling the CS lines of the NAND Flash. If different program images are stored therein, upon reset, different startup code is executed. NAND Flash is not currently supported on the system board. The current hardware implementation is not correct, but the future system board re-spin may incorporate a correct and supported implementation.

Table 7. Local Bus Chip Select Mapping

Flash Selection cfg_lbmap (0:3)	NOR Flash	PromJet	NAND Flash	ngPIXIS	Description
0000	LCS0	LCS1	LCS[2,4:6]	LCS3	Boot from NOR Flash region #0
0001	LCS0	LCS1	LCS[2,4:6]		Boot from NOR Flash region #1
0010	LCS0	LCS1	LCS[2,4:6]		Boot from NOR Flash region #2
0011	LCS0	LCS1	LCS[2,4:6]		Boot from NOR Flash region #3
0100	LCS0	LCS1	LCS[2,4:6]		Boot from NOR Flash region #4
0101	LCS0	LCS1	LCS[2,4:6]		Boot from NOR Flash region #5
0110	LCS0	LCS1	LCS[2,4:6]		Boot from NOR Flash region #6
0111	LCS0	LCS1	LCS[2,4:6]		Boot from NOR Flash region #7
1000	LCS1	LCS0	LCS[2,4:6]	—	Boot from PromJet, NOR Flash unbanked.
1001	LCS2	LCS1	LCS[0,4:6]	—	Boot from NAND Flash NOR Flash unbanked.
1010–1111	Not valid				

The “address toggle” feature mentioned in [Table 7](#) is implemented as multistaged XOR gate in-line with the most significant addresses of the Flash, as shown in this figure.

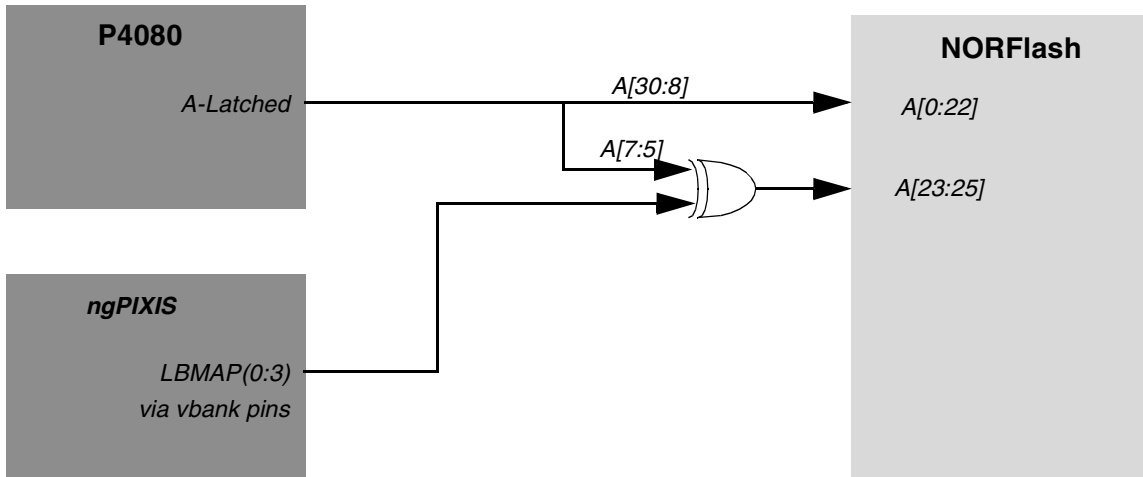

Figure 10. Flash Address Toggle

When LBMAP encoded bits A23–A25 of the Flash address are altered (toggled), as shown in [Table 7](#), the Flash behaves normally or is swapped around as virtual banks. Thus, the boot bank can be swapped around to support up to eight boot images with or without RCW.

5.1.6 eSDHC

The P4080 has an enhanced secure digital host controller (eSHDC). The P4080DS connects the eSDHC to an SDMedia card slot and uses GPIO signals for sideband signals, such as write-protect-detect and card-detect. Both x4 and x8 cards are supported, the latter using the SPI_CS_B[0:3] signals, which can be reassigned as eSHDC_D[4:7]. This figure shows the overall connections of the eSDHC block.

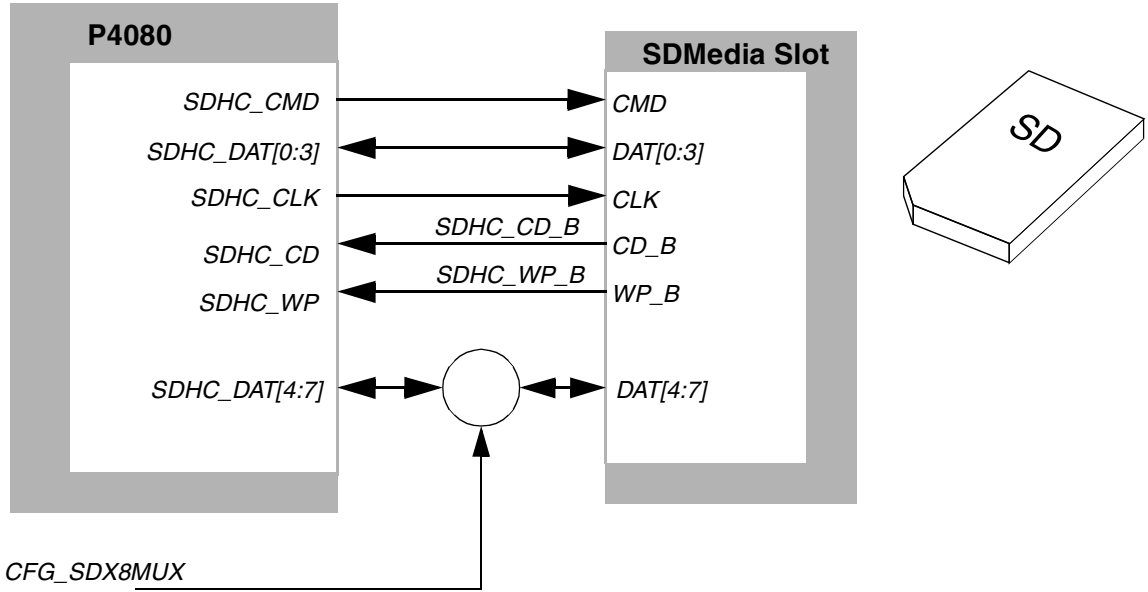

Figure 11. eSDHC Architecture

The SDHC_DAT[4:7] signals are shared with the SPI CS pins; software may select the routing of those pins to either the SDHC devices or the SPI devices, but both cannot be used simultaneously.

5.1.7 SPI Interface

The P4080 has a serial peripheral interface (SPI), which is used to communicate with various peripherals. The P4080DS connects a conventional 16-Mbyte serial EEPROM to one chip-select. The remaining three chip-selects are unused. This figure shows the overall connections of the SPI portion.

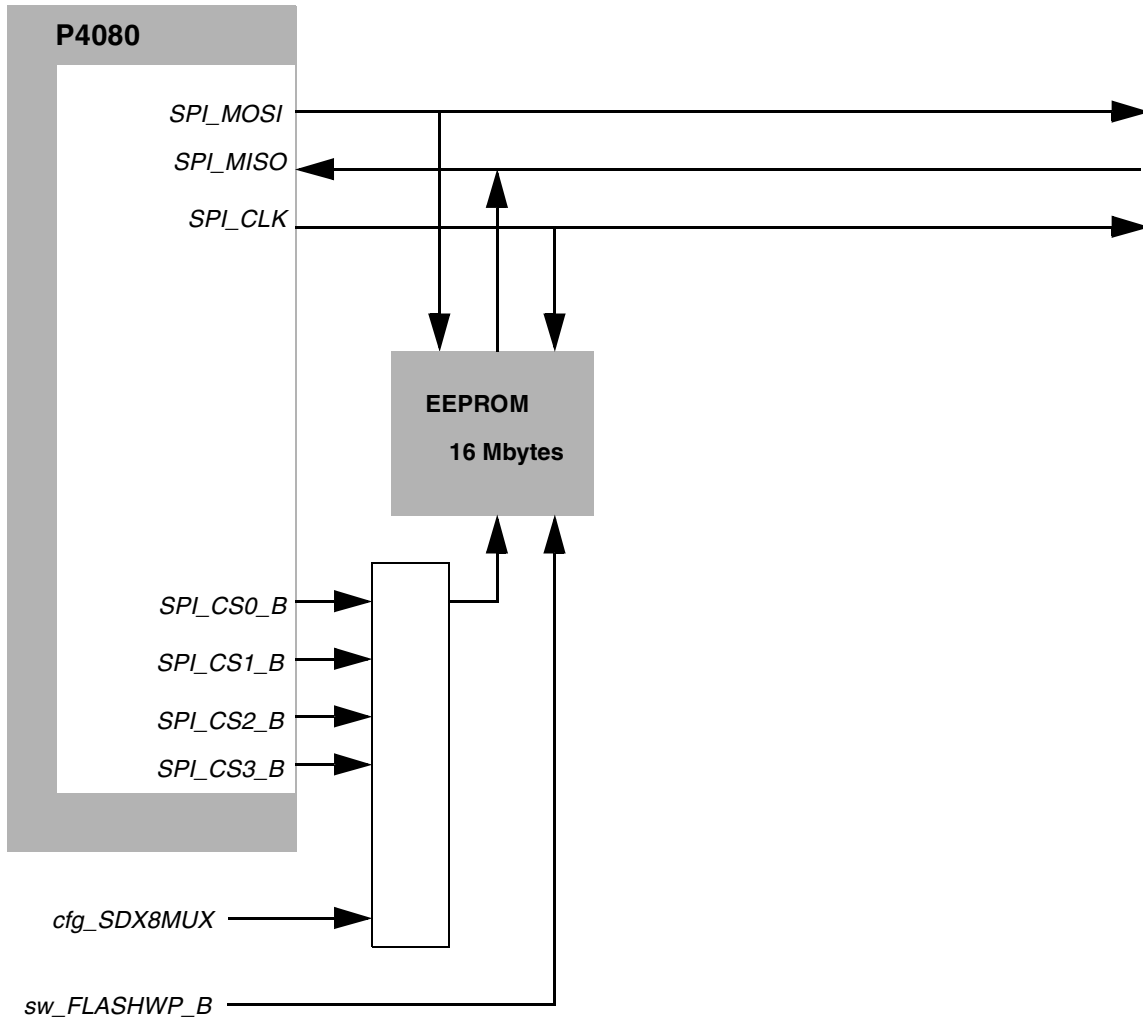

Figure 12. SPI Architecture

5.1.8 USB Interface

The P4080 has a USB 2.0 port that uses the UTMI+ protocol to connect to an external USB PHY, and may be configured for host or device modes. This figure shows the overall connections of the USB portion.

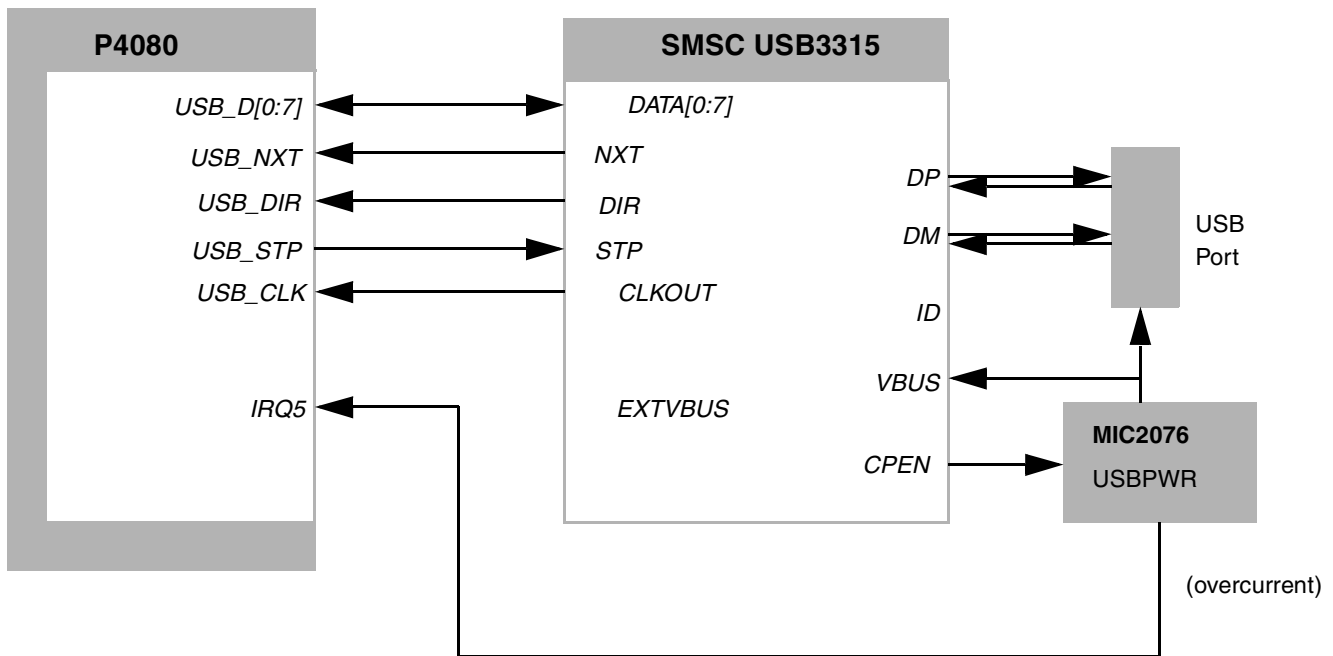

Figure 13. USB Architecture

The USB port connector is a female “Type A,” the standard connector for a host to communicate with keyboards, mice, memory sticks, and so on. To support evaluating peripheral mode, the ID pin of the USB3300 can be controlled with ngPIXIS using the “On-The-Go” mode to switch to peripheral mode. This requires a special adapter, because a host expects the target device to be either a male “Type A” or a female “Type B.”

5.1.9 DMA Controller

The P4080 DMA controllers have internal and external controls to initiate and monitor DMA activity. The P4080DS does not incorporate any specific devices that make use of the external pin-controlled DMA.

The DMA ports are connected to test points to allow external hardware control as needed.

5.1.10 eOpenPIC Interrupt Controller

The P4080DS contains numerous interrupt connections. This table shows the P4080 eOpenPIC connections.

Table 8. Interrupt Connections

Signal Names	Connections
IRQ0_B	SLOT3 Sideband connector (SGMII riser does not connect, must use in-band irq)
IRQ1_B	DS3232 Realtime CLOCK and NVRAM
IRQ2_B	Four ZL2006 VCORE alert outputs
IRQ3_B	VSC8244 PHY interrupts 0–2 (wire-ORed)
IRQ4_B	SLOT4 Sideband connector (SGMII riser does not connect, XAUI riser can use or inband)
IRQ5_B	MIC2076 USB Power FLAG for over current at USB connector
IRQ6_B	SLOT6 Sideband connector (SGMII riser does not connect, XAUI riser can use or inband)
IRQ7_B	Not Connected
IRQ8_B	ngPIXIS FPGA
IRQ9_B	ngPIXIS FPGA
IRQ10_B	ADT7461 Thermal Diode ALERT PIN
IRQ11_B	ADT7461 Thermal Diode THERM PIN
IRQ_OUT_B	Not used as Interrupt, but as an EVT pin

5.1.11 GPIO Controller Port

Several pins of the P4080 can be used for customer-specific applications. Some of these pins have alternate P4080-defined purposes to which they may also be used. All unused GPIO signals are connected to test points on the P4080DS board; for those that have additional functions, there are additional connections as noted. In general, additional functions are used so as not to interfere with use as GPIO unless otherwise noted. This table summarizes the dedicated GPIO signals.

Table 9. Dedicated GPIO Connections

Signal Names	System Function
GPIO[0:1]	EM1 management bus mux control.
GPIO[2:3]	EM2 management bus mux control.
GPIO[4:7]	Spares connected to test points.

5.1.12 Control Group

The P4080 control group signals are principally related to halting or restarting execution. This figure shows an overview of the connections.

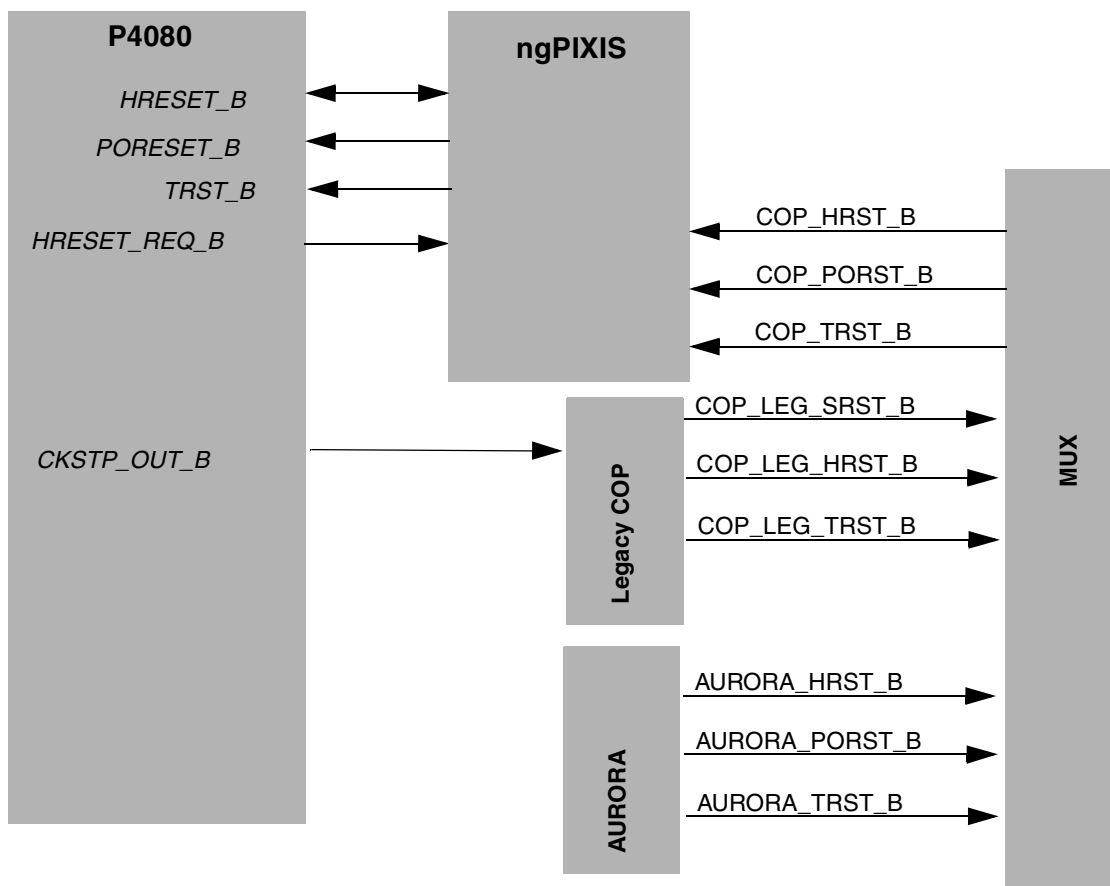

Figure 14. Control Architecture

The resets from the legacy COP and Aurora connectors are multiplexed to the ngPIXIS FPGA. The ngPIXIS FPGA can inject system-level resets along with the legacy COP or Aurora resets. Note that the Legacy COP HRST is mapped to the P4080 PORESET and the Legacy COP SRST is mapped to the P4080 HRESET. The P4080 HRESET is bi-directional open drain signal, but is not monitored by the ngPIXIS FPGA. Basic system reset is mapped to the P4080 PORESET for both cold and warm reset conditions.

5.1.13 UART Serial Ports

The P4080DS connects both 4-wire serial ports to serial level transceivers, and from there to a stacked dual DB9 male connector placed in the ATX I/O gasket area. The default mode is 4-wire, so RTS/CTS flow control is supported on these connectors.

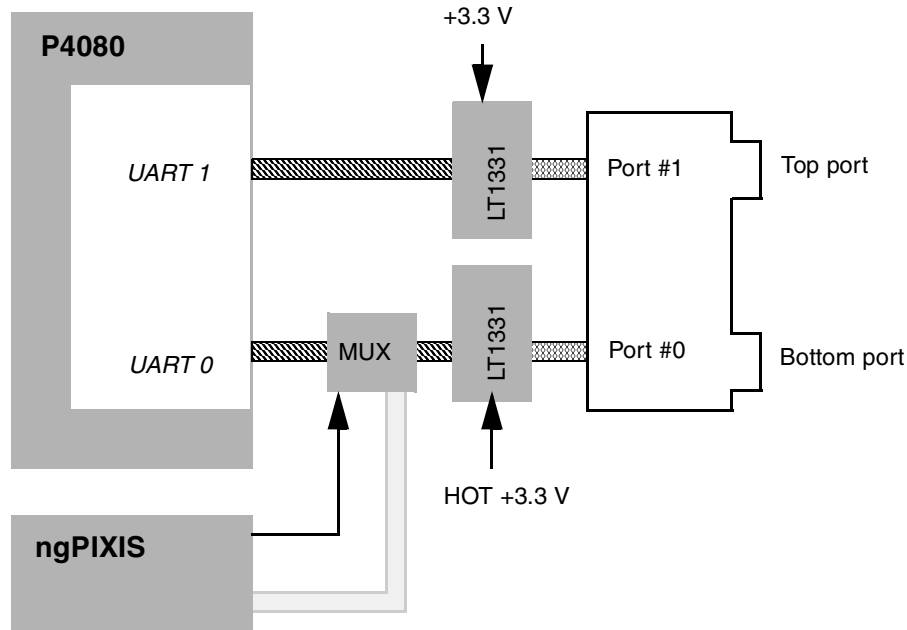

Figure 15. Serial Architecture

The UART programming model is a standard PC16550-compatible register set. Baud rate calculations for the divisor latch registers (DLL and DML) are typically done by reading the ngPIXIS PX_CLK register to determine the P4080 SYSCLK clock input (typically 133 MHz) frequency, but possibly any value. The baud rate divisors can then be calculated using the formula described in the *P4080 QorIQ Integrated Communications Processor Family Reference Manual*.

NOTE: Programming Note

If the dynamic reconfiguration capabilities of ngPIXIS are used to set the SYSCLK input to an arbitrary value, the 3 bits in the PX_CLK register are not valid. In this case, the PX_AUX register is, by convention, set to the value of SYSCLK in MHz, which is used in lieu of PX_CLK.

Note that the primary serial port is powered from the 3.3-V hot power rail, and thus may be used even when the system is powered down. This facility is used by the ngPIXIS processor to run programs and interact with the user, allowing reconfiguration of the board when sealed in the chassis.

5.1.14 I²C

The P4080 has four separate I²C/SMB buses; however, the P4080DS uses three of them. I²C1 is also electrically isolated before power-up of the P4080 so as to allow ngPIXIS access to eeprom resources. Those resources can be accessed by P4080 after power up. This figure shows the I²C block.

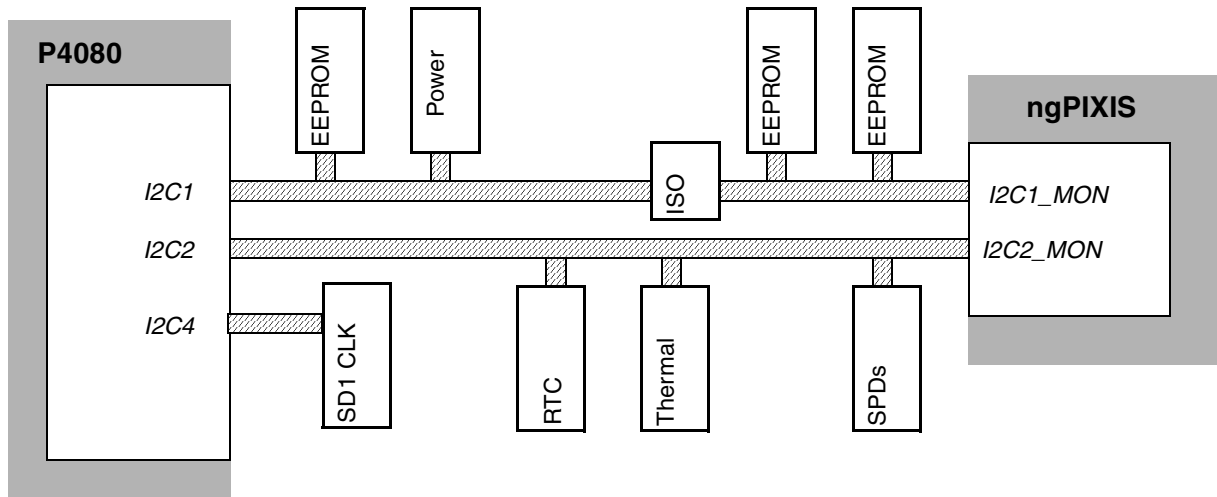
Figure 16. I²C Architecture

This table summarizes the I²C bus device addresses.

Table 10. I2C Bus Device Map

I ² C Bus	I ² C Address	Device	Notes
1	0x21	VCORE PMBus ZL2006 regulator	Controls rail VDD_CA
1	0x22	VCORE PMBus ZL2006 regulator	Controls rail VDD_CB
1	0x23	VCORE PMBus ZL2006 regulator	Controls rail VDD_PL
1	0x24	DDR PMBus ZL2006 regulator	Controls rail VDD_GVDD
1	0x50	4KiB EEPROM Atmel AT24C64A or equivalent.	Stores RCW and PBLOADER data. Write protectable.
1	0x55	4KiB EEPROM Atmel AT24C64A or equivalent.	Stores ngPIXIS accessed configuration data. Accessible while board is powered off. Write protectable.
1	0x56	4KiB EEPROM Atmel AT24C64A or equivalent.	Stores ngPIXIS GMSA program code. Accessible while board is powered off. Write protectable.
1	0x57	256B SYSTEM ID EEPROM Atmel AT24C02A or equivalent.	Stores board specific data, including MAC addresses, serial number/errata, and so on. Write protectable.
1	n/a	ngPIXIS I2C port	Used for bus reset, monitoring, and master-only data collection.
1	n/a	I2C Access Header	For remote programming of boot sequencer startup code (if needed) or Zilker Lab PMBus programmer.

Table 10. I2C Bus Device Map (continued)

I ² C Bus	I ² C Address	Device	Notes
2	0x4C	Processor Thermal Monitor Analog ADT7461A or equivalent	—
2	0x51	DDR3 DIMM Socket 1 Atmel AT24C02, Microchip MCP98242. or equivalent	SPD EEPROM Type of device depends on the DIMM vendor; the default Elpida device supplies an MCP98242.
2	0x52	DDR3 DIMM Socket 2 Atmel AT24C02, Microchip MCP98242. or equivalent	SPD EEPROM Type of device depends on the DIMM vendor; the default Elpida device supplies an MCP98242.
2	0x68	Real-time clock DS3232	Optional
2	n/a	ngPIXIS I2C port	Used for bus reset, monitoring, and master-only data collection.
2	n/a	I2C Access Header	For remote programming of boot sequencer startup code (if needed).
3	0x6E	SerDes clock generator ICS9FG108	—
3	n/a	I2C Access Header	For remote programming (if needed).

Note: These addresses do not include the position of the LSB of the transmitted address (the read/write bit).

5.1.15 EM1 and EM2 Management Busses

The P4080 has two types buses: one for SGMII and RGMII PHY management, and one for XAUI PHY management. Because one set of busses must span across multiple devices in the P4080DS system, multiplexers are used to route from the P4080 to each PHY. GPIOs are used to control the multiplexers.

These tables summarize the management bus control.

Table 11. PHY Management Bus Map for EMI1

Bus	GPIO[0:1]	Device
EMI1	00	On board Vitesse RGMII
EMI1	01	Slot 4 SGMII
EMI1	10	Slot 3 SGMII
EMI1	11	Slot 5 SGMII

Table 12. PHY Management Bus Map for EMI2

Bus	GPIO[2:3]	Device
EMI2	00	No Device
EMI2	01	Slot 4 XAUI

Table 12. PHY Management Bus Map for EMI2 (continued)

Bus	GPIO[2:3]	Device
EMI2	10	No Device
EMI2	11	Slot 5 XAUI

5.1.16 Debug and Power Management

This table summarizes the debug and power management signals.

Table 13. Debug and Power Management Connections

Signal Names	Connections
EVT[2,3,7,8]	P6880 Debug header
MSRCID[0:2]	P6880 Debug header
MDVAL	P6880 Debug header
CLK_OUT	Test point w/adjacent ground.
ASLEEP	ngPIXIS LED

5.1.17 Clock

This table summarizes the clocks for the P4080. Further details on the clock architecture are covered in [Section 5.4, “Clocks.”](#)

Table 14. P4080 Clock Connections

Pin Count	Signal Names	Connections
1	SYSCLK	ICS307 System clock synthesizer
1	RTC	Arbitrary timebase frequency
11	Total pins in this group	

NOTE

The SerDes and Ethernet clocks are included in their respective sections.

5.1.18 Temperature

The P4080 has two pins connected to a thermal body diode on the die, allowing direct temperature measurement. These pins are connected to the ADT7461 thermal monitor, which allows direct reading of the temperature of the die and is accurate to ± 1 °C. This figure shows the thermal management scheme for the P4080DS.

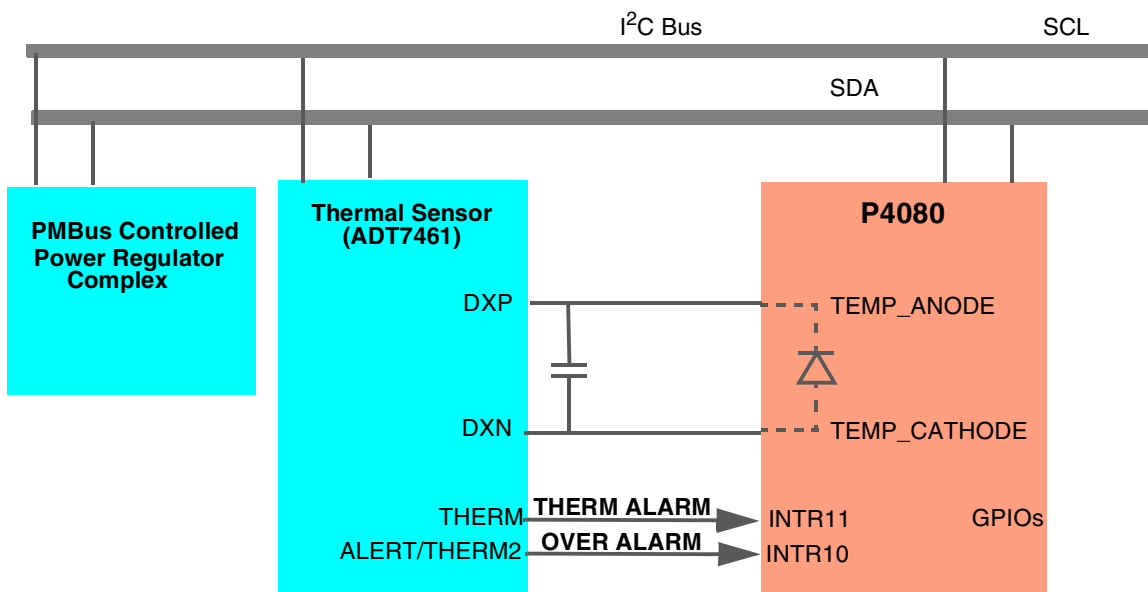

Figure 17. Functional Block Diagram of P4080DS Thermal Management Scheme

5.1.19 Power

The power requirements of the P4080 are estimated at this time, based on historical precedents and estimated power requirements. These figures show the power architecture for the P4080 as implemented on the P4080DS.

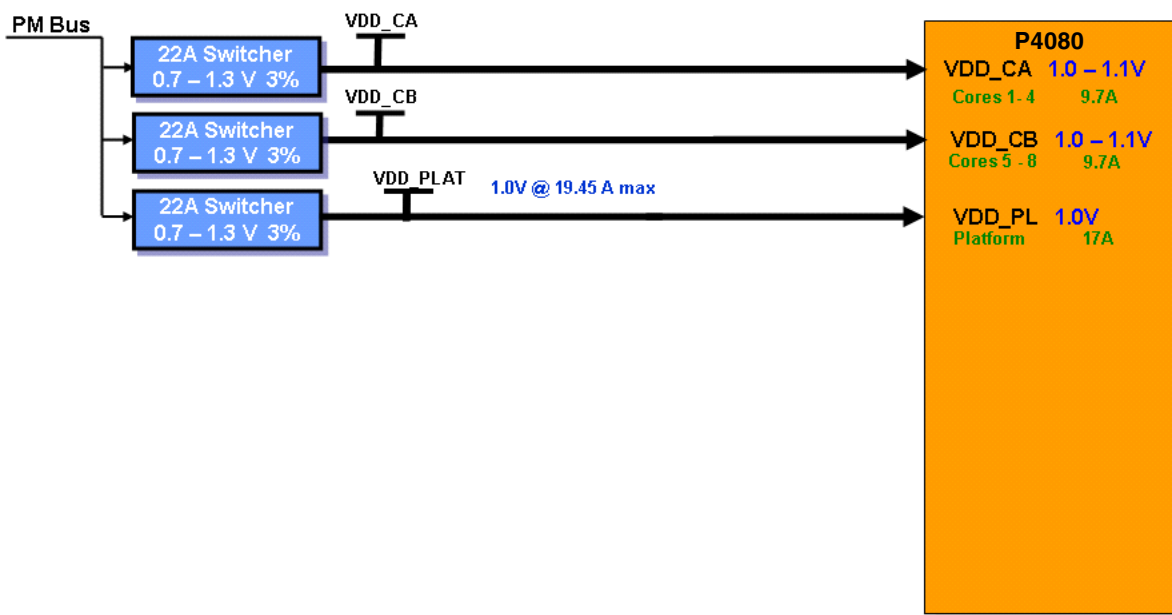

Figure 18. P4080DS Power Architecture for P4080 Part 1 of 3

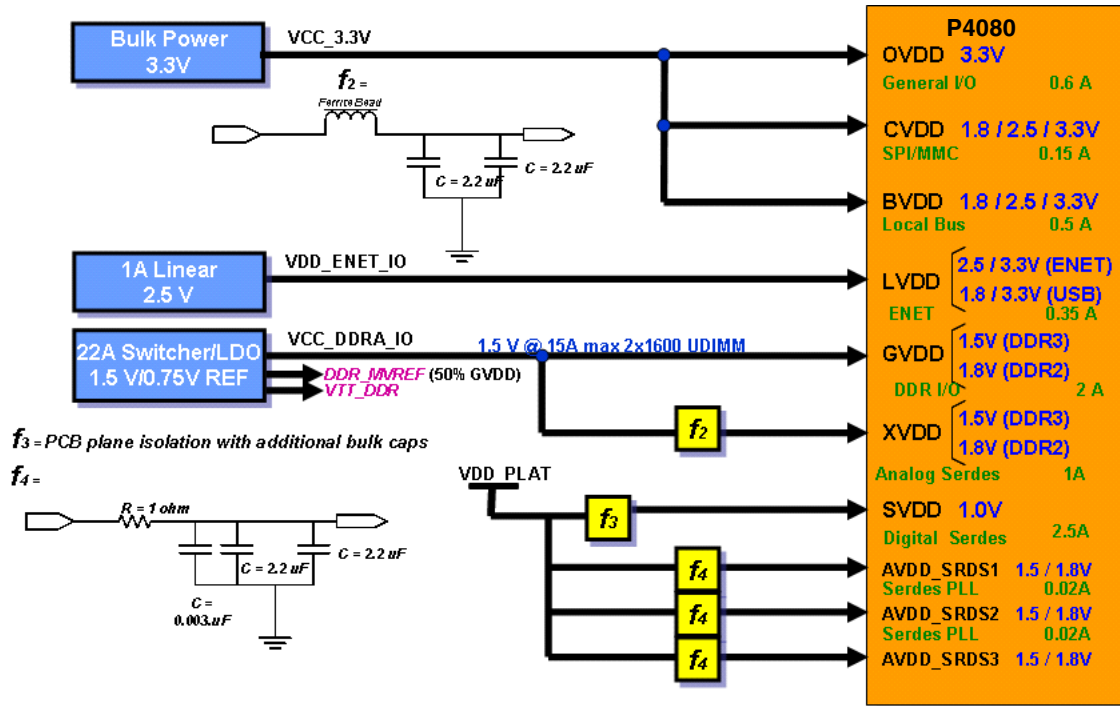

Figure 19. P4080DS Power Architecture for P4080 Part 2 of 3

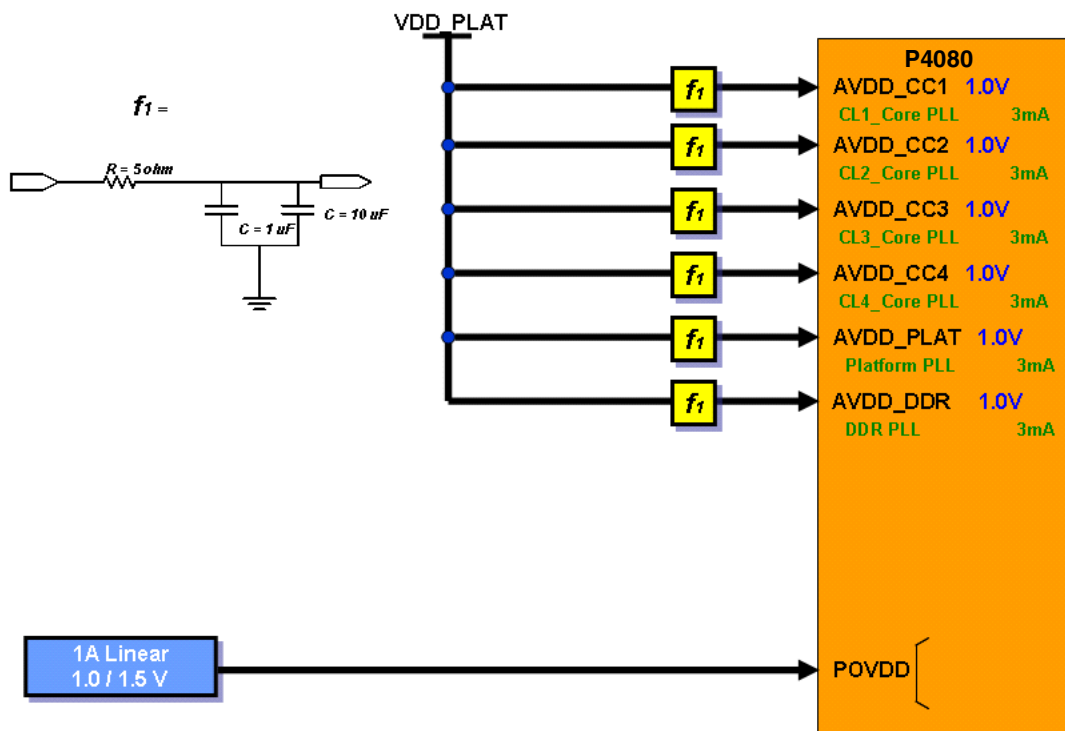

Figure 20. P4080DS Power Architecture for P4080 Part 3 of 3

Note that this is the power for the P4080 only as implemented on the P4080DS; it does not include external devices, memory, and so on. Because these are estimates, and because alpha silicon tends to be “hot,” the VDD rail must have an excess capacity of approximately 20%.

Note also that the P4080 supports more than these voltage levels, but they are the voltage levels supported by the P4080DS.

Because of the high-current transients present on the VDD power pins, careful attention should be paid to properly bypass these power pins and to provide a good connection between the BGA pads and the power and ground planes. In particular, the SMD capacitors should have pads directly attached to the via ring (or within it, if the PCB costs are not prohibitive).

5.2 System Control Logic

The P4080DS contains an FPGA, the ngPIXIS, which implements the following functions:

- Reset sequencing/timing combined with COP/JTAG connections.
- Map/re-map P4080 local bus chip selects to Flash, compact Flash, and so on.
- Transfer switch settings to processor/board configuration signals.
- Load configuration data from RAM (registers) or EEPROM to override configuration for self-test.
- Miscellaneous system logic
 - COP reset merging
 - DMA trigger/monitor registers
 - I²C timeout reset

The FPGA is powered by standby power supplies and an independent clock. This allows the FPGA to control all aspects of board bringup, including power, clocking, and reset.

The ngPIXIS is implemented in an Actel A3P600 in a 484-256-pad micro-BGA. This figure shows the overall ngPIXIS architecture.

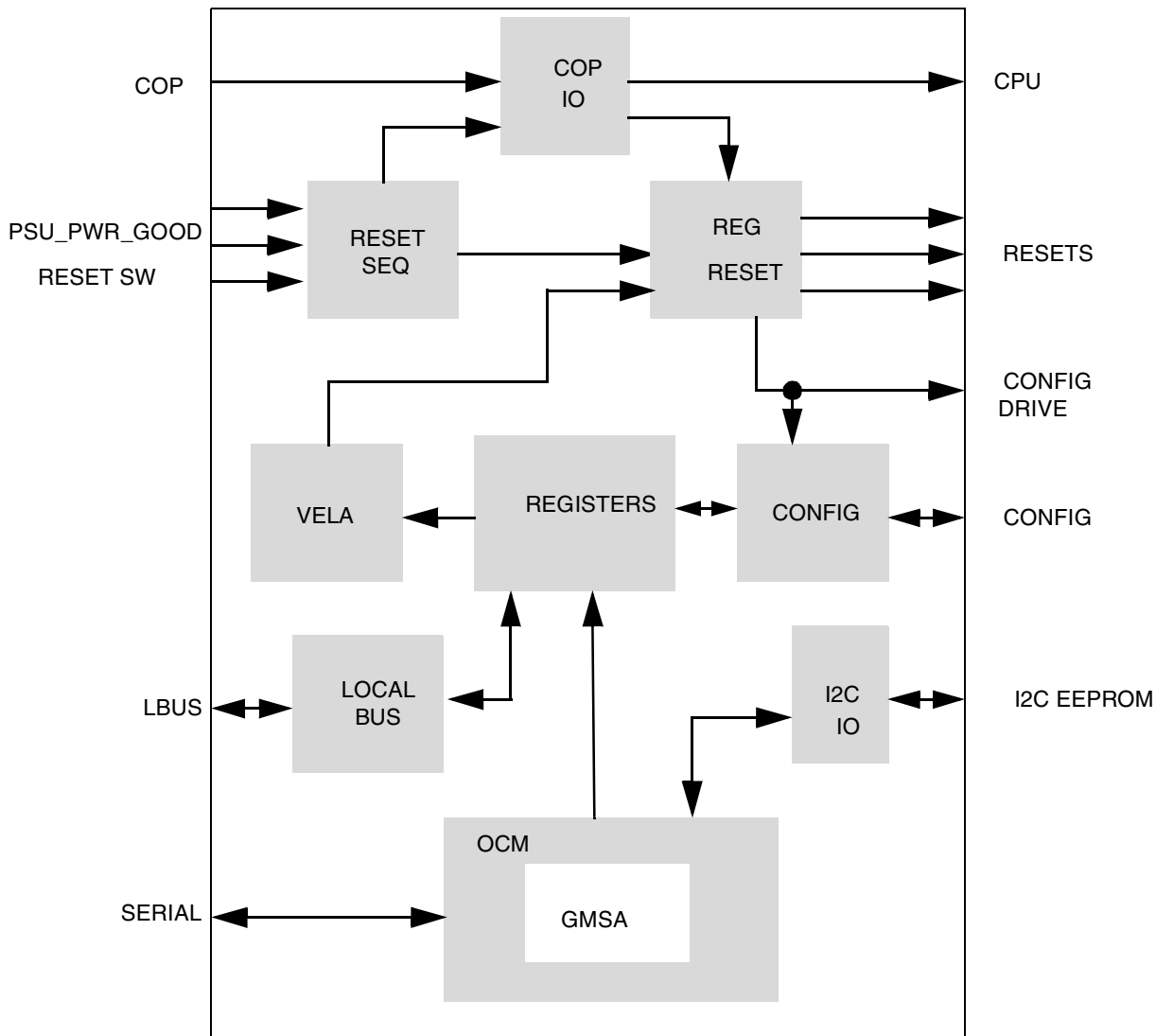

Figure 21. ngPIXIS Overview

The principal portions of ngPIXIS are as follows:

- COP Handles merging COP header resets with on-board resets in a transparent manner
- RESETSEQ Collects various reset/power-good signals and starts the global reset sequencer
- REGRESETS Drives resets from the sequencer, from register-based software control, or from VELA
- REGISTERS A multi-ported register file containing status and configuration data
- LOCALBUS Interface between processor and REGFILE
- CONFIG Monitors and/or sets selected configuration signals

Architecture

VELA	VELA is a simple machine to monitor requested changes in board configuration and when detected, perform a power-on-reset/re-configuration of the target system.
OCM	Offline configuration manager—a machine that initializes the ngPIXIS registers, including those used for P4080 initialization, from external I ² C EEPROMs. The OCM can talk to the user or another computer using the serial port while the system is powered down.
GMSA	General microprocessor/stack architecture—a stack-based microprocessor that loads executes before and during power-down/-up events. It can query I ² C devices and collect data during normal system operation, as well as allow setting configuration switches without opening the chassis.

5.2.1 COP

COP handles merging COP header resets with on-board resets in a transparent manner. It is critical that the COP HRST* input resets the entire system except for the COP JTAG controller (that is, TRST* must not be asserted). With COP not attached, it is critical that reset does indeed assert TRST*. The COP core manages these modal operations.

5.2.2 RESETSEQ

RESETSEQ collects various reset/power-good signals and starts the global reset sequencer.

Note that ASLEEP indicates that the processor(s) have exited the reset state. It does not cause a reset, because the processor can sleep for any number of reasons after hard reset is completed.

Note also that during power-down, all I/O and output drivers must be tristated. After power up, drivers may be driven. Normal operation and/or use of the VELA engine may cause some I/Os to be tristated.

5.2.3 REGRESETS

REGRESETS copies reset signals from the sequencer, but also allows register-based software to individually asserted reset to the local bus, memory, and/or compact Flash interfaces.

5.2.4 REGFILE

REGFILE is a dual-ported register file containing several types of registers.

Note that REGFILE must be able to accept (or arbitrate for) concurrent writes to the same register, though this is not a statistically likely occurrence.

5.2.5 LOCALBUS

LOCALBUS is the interface between processor and REGFILE. Because access to the internal registers may be blocked, asynchronous (not ready) signalling is used.

5.2.6 CONFIG

CONFIG monitors and/or sets selected configuration signals.

In some instances, CONFIG maps switch settings into direct configuration outputs, while in others (such as SYSCLK), it maps a 3-position switch into a 16-bit register initialization pattern, which is subsequently used to initialize the clock generator.

5.2.7 VELA

VELA is a simple microsequencer used to monitor sequence in requested changes in board configuration upon a signal (generally a register write from PCI). When detected, bits in a PX_EN[1:8] register allow a corresponding PX_SW[1:8] register to be driven onto configuration pins during a system restart.

5.2.8 OCM

The off-line configuration manager (OCM), is a small microprocessor (GMSA) that contains an embedded CPU core, 8-Kbyte SRAM and I/O peripherals (UART, I²C, GPIO and timers). The standard OCM software performs the following functions:

- Monitors PX_VCTL[GO] to avoid interfering with self-shmoo
- Loads ngPIXIS SW/EN registers from external I²C EEPROM
- Modifies ngPIXIS misc registers from external I²C EEPROM
- Modifies VCORE output voltage based on SW_VCORE(0:1) settings
- User interaction to allow programming I²C EEPROM (even with power off)
- Background data collection on VCORE, ICORE, TEMP, and so on
- Other system control functions (reset, power cycle, and so on)

This figure shows the block diagram of the OCM component.

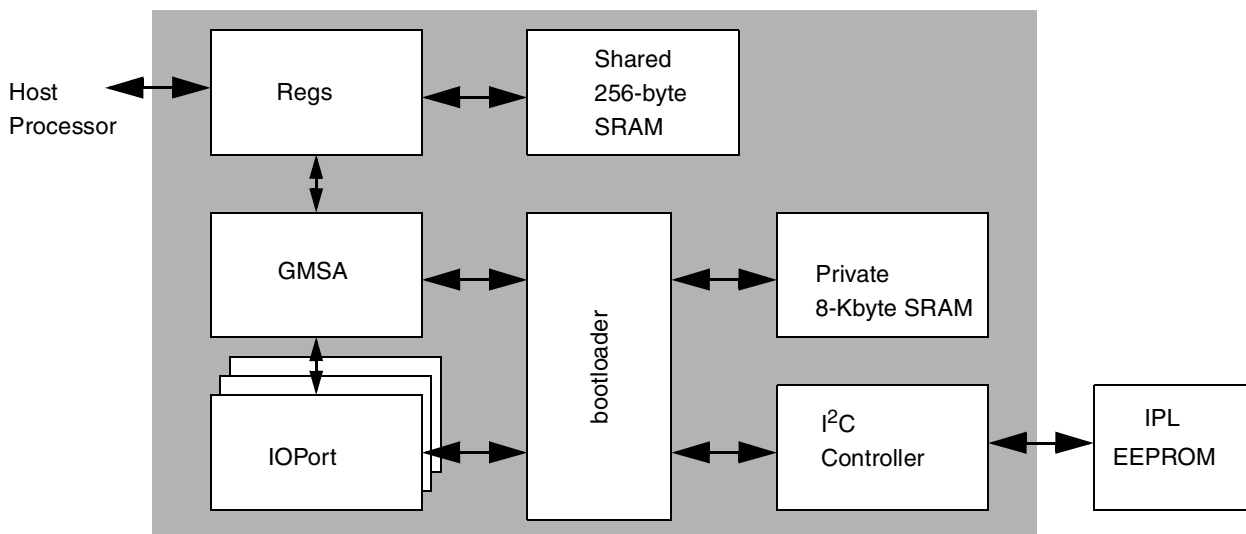

Figure 22. OCM GMSA Implementation

A great portion of the OCM is defined by the software. Because this can be changed by the end-user or updated with new functions at any time, see the OCM documentation for definitive details.

5.2.9 Power

Power for ngPIXIS is supplied from dedicated VCC_HOT_3.3 and VCC_HOT_1.5-V power supplies based upon the ATX power supply +5-V standby power, VCC5STDBY.

5.2.10 Register Summary

ngPIXIS contains several registers. For further details, see [Section 7.1, “ngPIXIS Registers.”](#)

5.3 System Power

The 12-V, 5-V, and 3.3-V power requirements are met by the attached ATX-12V compatible power supply unit (PSU). 5 V and 3.3 V are connected to individual power planes in the P4080DS PCB stackup. The 12-V power from the standard ATX header is treated as separate from the ATX-12V power, which supplies a large amount of current and is referred to as “VCC_12V_BULK”. The latter is used solely for the VDD_CA, VDD_CB, and VDD_PL power supply rails, while the former is used for miscellaneous purposes, such as fan power and PCI slots.

Note that to support ngPIXIS standby operation, video cards, or other high-power-dissipation cards in the PCIeExpress slot, the PSU should support the following minimum specifications:

- Minimum 450 W overall, 500 W recommended
- One PCIE 12-V connector
- PCIE 12 V supports a minimum of 150 W
- Minimum 5-V, 2-A standby current

All other power sources are derived from the ATX PSU. [Figure 23](#) shows the principal system power connections in relationship to FPGA control. For more detail as to P4080 power scheme as implemented by this system, see [Section 5.2.9, “Power.”](#)

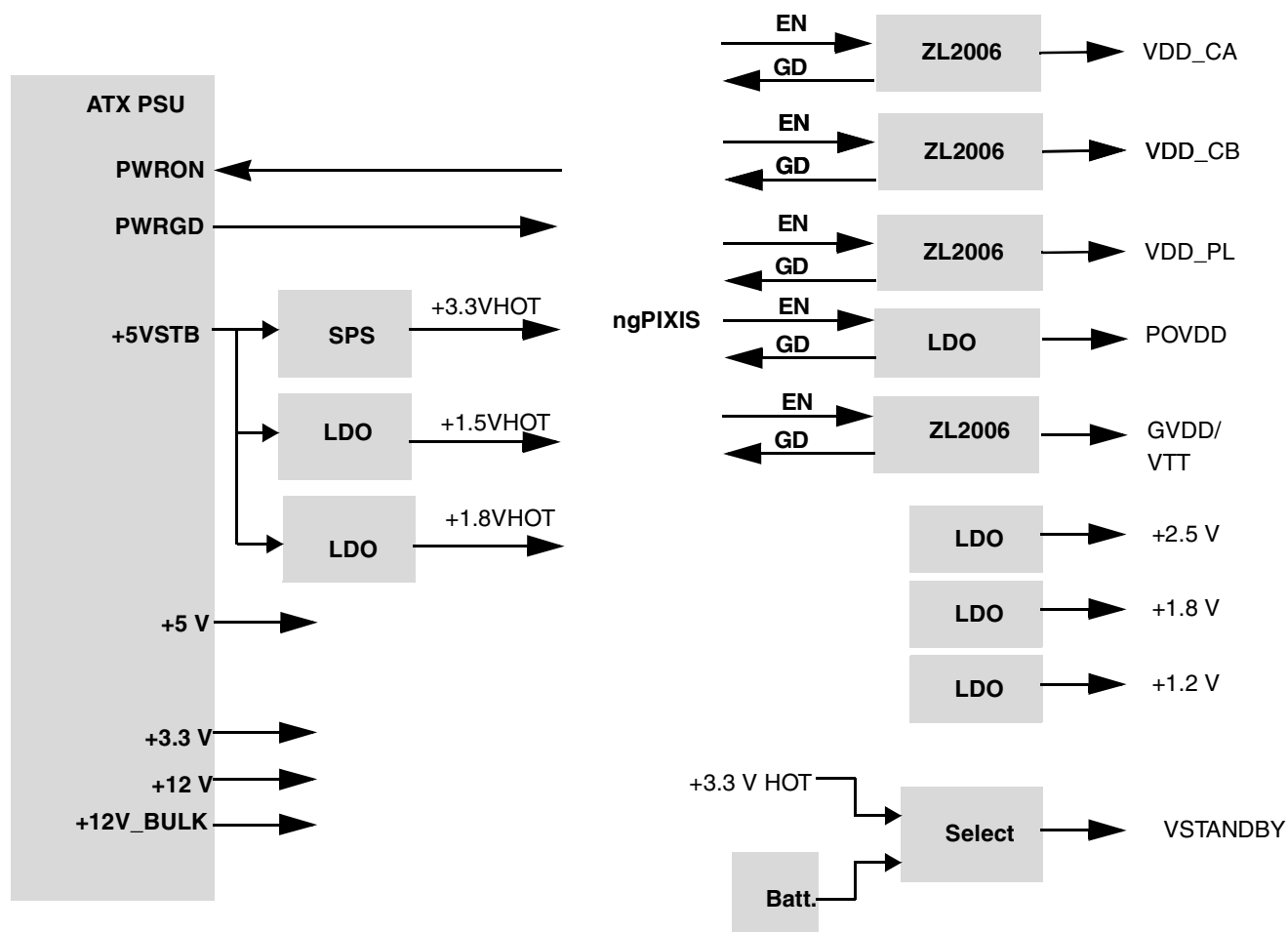

Figure 23. Expedition Power Architecture

5.3.1 Core and Platform Power

The P4080DS uses the Zilker Labs ZL2006 switching power controller. The P4080DS uses this device as a single-phase controller for up to 22 A of power at a nominal 1.0- to 1.10-V output. Four switchable values are available for experimentation see [Section 6.1.2, “Configuration Switches.”](#) Of particular interest is the PMBus capabilities of the ZL2006; the P4080DS uses hardware configuration pins to set the nominal voltage to 1.10 V, but using PMBus commands, nearly any parameter of the design can be adjusted by software, including the following:

- Output voltage
- Current limit
- Slew rate
- Power-up delay
- Droop compensation
- Margining

In addition, the SNAPSHOT command allows collection of data, including paired voltage and current measurements. See the ZL2006 data sheet and the PMBus association specifications for further details.

5.3.2 GVDD/VTT DDR Power

The P4080DS uses the Zilker Labs ZL2006 switching power controller as a single-phase controller for up to 22 A of power at a nominal 1.5-V output. As with the Core and Platform power regulators, the PMBus may be used; however, there are no switchable values. This device supplies both GVDD, while an LDO, it supplies half of this voltage as VTT (termination power), and MVREF (switching reference voltage) for the DDR DIMM and the P4080 DDR interface.

5.3.3 XVDD/SVDD SerDes Power

XVDD is a filtered copy of the DDR power GVDD. There is a backup LDO as an alternative source of XVDD. Filtering is the primary choice, while the LDO is for experimentation. SVDD is a filtered copy of Platform power VDD_PL.

5.4 Clocks

This table summarizes the clock requirements of the P4080DS. Note that the DDR clocks are not included, because they are provided by the P4080.

Table 15. P4080DS Clock Requirements

Clock	Destination	Clock Frequency	Specs	Type	Notes
SYSCLK	P4080 SYSCLK	33–200 MHz	$t_R \leq 1\text{ns}$ $t_F \leq 1\text{ns}$ $\leq 60\%$ duty $\leq 150\text{ ps}$ jitter	LVTTTL	133.33 nominal closed loop jitter bandwidth should be $<500\text{ kHz}$ at 20 dB.
BCLK	P4080 RTCCLK	14.318 MHz	none	LVTTTL	—
	P4080 SD1_REFCLK(p,n)	100.00 MHz or 125.00 MHz	jitter: 80–100 ps skew: 330 ps	LVDS	100.00 MHz 100 ps jitter
SD1 REFCLK	SLOT1 REFCLK(p,n)	—	—	—	—
	SLOT2 REFCLK(p,n)	—	—	—	—
	SLOT3 REFCLK(p,n)	—	—	—	—
SD2 REFCLK	P4080 SD2_REFCLK(p,n)	156.25 MHz or 125.00 MHz	—	—	—
	SLOT4 REFCLK(p,n)	—	—	—	—
SD3 REFCLK	P4080 SD3_REFCLK(p,n)	156.25 MHz or 125.00 MHz	—	—	—
	SLOT5 REFCLK(p,n)	—	—	—	—

Table 15. P4080DS Clock Requirements (continued)

Clock	Destination	Clock Frequency	Specs	Type	Notes
GTXCLK	P4080 EC_GTX_CLK125 VSC8244 XTAL1	125 MHz	—	—	—
UPHYCLK	USB PHY clock	26.000 MHz	—	LVTTTL	—

This figure shows the principal clock connections (DDR and miscellaneous clocks are not shown).

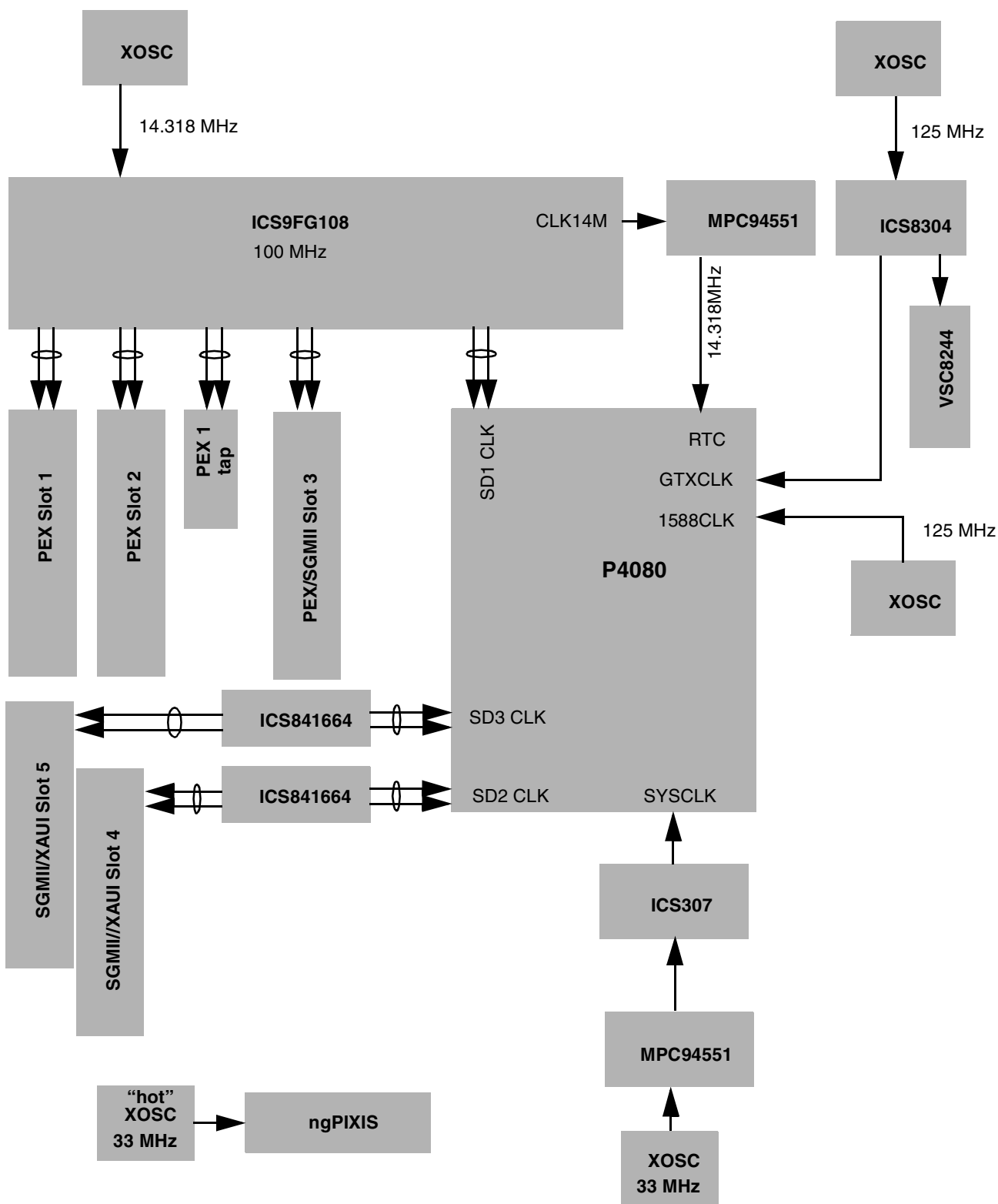

Figure 24. P4080DS Clock Architecture

5.4.1 SYSCLK

Much of the timing within the P4080 is derived from the SYSCLK input. On the P4080DS, this pin is controlled by an IDT ICS307-02 frequency synthesizer. This device is serially configured by 20 found bits of data by the ngPIXIS as part of the reset/power-up sequence. These 24 bits can be controlled to set the SYSCLK speed to fine increments using the dynamic (re)configuration facilities of remote access ngPIXIS. To make configuration easy, ngPIXIS pre-loads the 24-bit configuration pattern using one of eight popular values by sampling three switches located on the motherboard. This table summarizes the switch-selectable clock generation possibilities.

Table 16. SYSCLK Frequency Options

cfg_sysclk	Selected SYSCLK	Actual SYSCLK	Error	ICS307 Control Word	Notes
0 0 0	66.666 MHz	66.6660 MHz	0 ppm	0x270501	—
0 0 1	75.000 MHz	74.999 MHz	10 ppm	0x230984	—
0 1 0	83.333 MHz	83.3325 MHz	6 ppm	0x230381	—
0 1 1	90.000 MHz	89.999 MHz	10 ppm	0x230983	—
1 0 0	100.000 MHz	99.9990 MHz	10 ppm	0x230501	—
1 0 1	111.000 MHz	111.110 MHz	9 ppm	0x260381	—
1 1 0	125.000 MHz	124.998 MHz	10 ppm	0x210382	—
1 1 1	133.333 MHz	133.332 MHz	7.5 ppm	0x210201	—

Table 16 is based upon a 33.333-MHz reference clock input. The “Control Word” field is the data sent to the ICS307 upon startup, or when commanded to by the VELA controller. This value can be calculated from the ICS307 data sheet examples, or using the convenient online calculator IDT provides. In the cases above, whenever different values are calculated for frequency accuracy vs. lowest-jitter, the lowest-jitter parameter was chosen.

5.5 System Reset

The P4080DS ngPIXIS contains a reset sequencer used to properly manage the orderly bring-up of the system (this is not the same as the power sequencer, which is similar, but not specifically related to reset).

Once the system has transitioned to having fully stable power supplies, the reset sequencer waits for all reset conditions to clear, configures and releases the processor from reset, then idles waiting for further reset conditions to occur. This table summarizes reset conditions and actions.

Table 17. Reset Terms

Term	Type	Description	Notes
HOT_RST_B	External	HOT power stable	Restarts all ngPIXIS internal state machines and registers
PWRGD	External	ATX power stable	Causes full system reset unless the system is in S3 (power down) state.
COP_HRST_B	External	COP tool reset request	Triggers reset, but must never cause CPU_TRST_B to be asserted

Table 17. Reset Terms (continued)

Term	Type	Description	Notes
RESET_REQ_B	External	CPU requests reset	Full reset
tgtrst_b	Internal	Reset request from OCM software	Causes full reset always
rstall	Internal	PX_RST register write	Full reset
go	Internal	ngPIXIS shmoo logic restart request	Causes full reset except: PX_AUX registers are not changed.
wdtrst_b	Internal	Watchdog timer expired	Causes full restart including shmoo changes, if any

6 Configuration

The configuration options are categorized by the following:

- Requiring software configuration to support evaluation
- Expected to be easily and often changed by the end-user/developer
- Should rarely or never be changed

The first two options are implemented with “DIP switches” and/or software-settable options, while the latter set are usually implemented by resistors that must be added or removed by competent technicians.

This figure shows the configuration logic for those signals configured using switches.

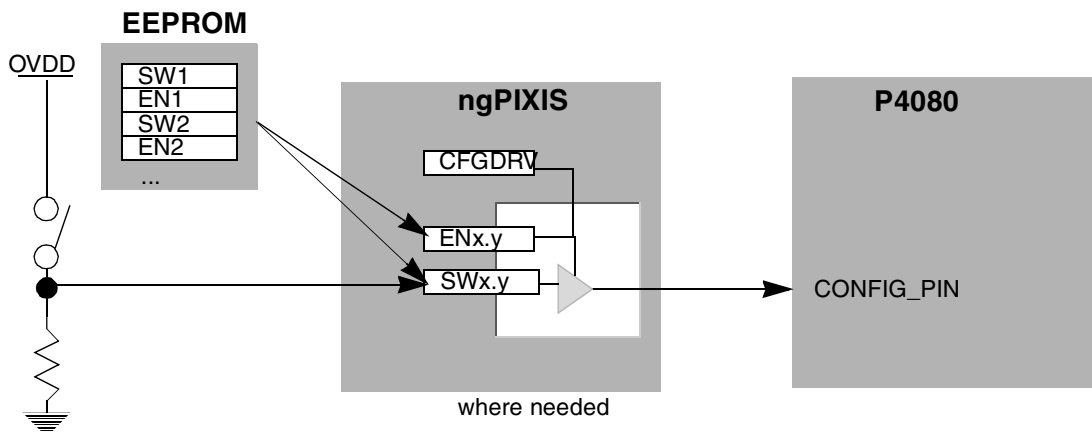

Figure 25. Configuration Logic

The default action is for the ngPIXIS to transfer the switch setting to the processor configuration pin during the $\overline{\text{HRESET}}$ assertion interval.

In addition, software running on the P4080 can initialize internal registers (such as SWx and ENx) to allow a board to configure itself for the next restart (termed “self-shmoo” or “self-characterization”).

A third option allows the ngPIXIS to copy configuration data from an external I²C EEPROM upon reset, and apply those values to the SWx/ENx registers (ignoring the external hardware switches). This allows dispensing with the expensive DIP switches and their corresponding difficulties with set-up and configuration preservation.

6.1 Configuration Options

The P4080DS uses the OCM function in the ngPIXIS to control how the board is configured as part of the normal power-up sequence. The OCM monitors a two-position switch, which allows selecting one of the configuration modes shown in this table.

Table 18. P4080DS Configuration Options

SW_CFGOPT(0:1)	Configuration Mode	Description
00	Bypass	Switch settings control all system configurations. No software in the OCM is executed. The following functions are NOT available: <ul style="list-style-type: none"> • Real-time PVT data collection • VCORE voltage changes
01	n/a	—
10	Memory	If VCTL=1 (self-shmoo is in process), no changes are made; otherwise, Pixis SW/EN registers are loaded from external EEPROM, and for every bit in a control all system settings, For every bit in an enable register that is set to one, the corresponding bit in a switch register is driven onto the board during HRESET.
11	Interactive	Same as “Memory” mode, except that during startup, the OCM pauses and allows the user to alter and optionally re-write the memory with new configuration settings with a UART connected to COM1. If no IO is received within 20 seconds, IO is stopped and “Memory” mode is used.

6.1.1 Configuration Modes

This section describes the various configuration modes.

6.1.1.1 Bypass

In bypass configuration mode, the GMSA processor is kept in reset, so no OCM software runs. No switch settings can be changed; whatever is selected on the configuration switches is used during the $\overline{\text{HRESET}}$ configuration sampling interval.

It is also possible for the system to change its own configuration registers and initiate a software-controlled restart (“self-shmooing”), just as with previous platforms.

This mode is backwards-compatible with previous generation platforms.

6.1.1.2 Memory

In memory configuration mode, the ngPIXIS registers are initialized as in [Section 6.1.1.1, “Bypass.”](#) If the system is not in self-shmoo mode, the OCM loads values from the SW(1:8) and EN(1:8) registers from the I²C-based EEPROM storage at device address 0x55. This device is isolated and powered from the standby power supply and is available even before the system has been powered up.

The OCM transfers data from the EEPROM into the ngPIXIS SW/EN registers, as shown in this table.

Table 19. OCM Configuration Data Format

I ² C EEPROM	Description	ngPIXIS Register	
Source Addresses		Destination Address	
0x00 – 0x03	EEPROM header	—	
0x08	Set Selection bit 3=1: Use VCORE value bit 3=0: Do not use VCORE bit 0(lsb)=0: Use Set A bit 0(lsb)=1: Use Set B	—	
0x20..0x3F	Set A: SW1, EN1 SW2, EN2 SW3, EN3 SW4, EN4 SW5, EN5 SW6, EN6 SW7, EN7 SW8, EN8	SW(x)	EN(x)
		20	21
		22	23
		24	25
		26	27
		28	29
		2A	2B
		2C	2D
		2E	2F
0x40..0x5F	Set B: SW1, EN1 SW2, EN2 SW3, EN3 SW4, EN4 SW5, EN5 SW6, EN6 SW7, EN7 SW8, EN8	SW(x)	EN(x)
		40	41
		42	43
		44	45
		46	47
		48	49
		4A	4B
		4C	4D
		4E	4F
0x70, 0x71	VCORE output code (if enabled)	PMBus output code (MSB first)	
0xA0, 0xA1	ngPIXIS register edits. Ends on values of 0x00 or 0xFF	Address, then Data	

The OCM examines the LSB of byte 0x08, and transfers either “Set A” (LSB = 0) or “Set B” (LSB = 1).

In all cases, when the registers have been loaded during reset configuration, wherever an EN register has a bit set to “1”, the corresponding bit in a “SW” register is used to replace the selected switch setting. For example, if all EN(1:8) registers are set to all ones, no external switch settings is used, so the system is purely EEPROM-configured. This allows a system cost reduction by eliminating all but one of the (fairly expensive) DIP switches. Conversely, if all EN(1:8) registers are set to all zeros, the register settings are unchanged and the external switch settings are used.

During memory configuration mode, the OCM is still running code. The target system may communicate with it via message passing; see [Section 5.2.8, “OCM,”](#) for details.

6.1.1.3 Interactive

In interactive configuration mode, the OCM prints a message to the COM1 serial port (115200, 8/N/1) and waits up to 20 seconds for a keypress. During this time, if the system is powered up, it pauses until this

delay has completed. If no character is received, the OCM mode falls back to memory configuration mode. Otherwise, while the system is still prevented from powering up, commands are accepted over the serial port, allowing SW/EN registers to be edited in memory. When the user has completed any configuration commands, the “GO” command allows the normal power-up sequence to proceed.

6.1.2 Configuration Switches

The SW registers are formatted as shown in this table.

Table 20. Configuration Switches Format

DIP Switch Label	1	2	3	4	5	6	7	8
ngPIXIS Register Bit (Power Arch. “big endian” format)	0	1	2	3	4	5	6	7

Switch names exactly match the name on the schematics and on the printed-circuit board in most cases, except where a spare has been newly assigned and only an FPGA has changed. See the *P4080DS Configuration Sheet*, which helps configure the system to a default configuration and has more detail as to the functionality of the these switches. It is also the most up-to-date document for any addition or change in features before [Appendix A, “References,”](#) is updated. This table summarizes the switches.

Table 21. Configuration Switches

Group	Switches	Configuration Signals	Class
SW1	(1–5)	cfg_rcw_src[0:4]	Dynamic
	(6)	cfg_dram_type	
	(7)	cfg_rsp_dis	
	(8)	cfg_elbc_ecc	
SW2	1	cfg_eng_use[0]	Dynamic
	2	cfg_eng_use[1]	
	3	cfg_eng_use[2]	
	4	cfg_eng_use[3]	
	5	cfg_eng_use[4]	
	6	cfg_eng_use[5]	
	7	cfg_eng_use[6]	
	8	cfg_eng_use[7]	
SW3	1	sd1_refspread	Static
	2	sd1_refcksel	
	3	sd2_refcksel	
	4	sd3_refcksel	
	5	n/a	—
	(6–8)	sysclk[0:2]	Static

Table 21. Configuration Switches (continued)

Group	Switches	Configuration Signals	Class
SW4	1	cfg_gpinput0	Dynamic
	2	cfg_gpinput1	
	(3–5)	cfg_svr[0:1]+cfg_testsel_b	
	6	n/a	—
	7	n/a	—
	8	i2c1_proc_iso	Static
SW5	(1–8)	spares	—
SW6	(1–2)	vdd_pl[0:1]	Static
	(3–4)	vdd_ca[0:1]	
	(5–6)	vdd_cb[0:1]	
	7	vdd_cb_en	
	8	vdd_povdd_en	
SW7	(1–4)	lbmap[0:3]	Static
	5	spare6	—
	6	spare7	—
	7	spare8	—
	8	rstreq_en	Static
SW8	1	spare1	—
	2	i2c_rcw_wp	Static
	3	flash_wp_b	
	4	id_wp	
	5	aurora_clk_en	
	6	povdd_cntl	
	7	rstreq_mode	Static
	8	legacy_pod_b	—
SW9	1	cfg_pixisopt[0]	Static
	2	cfg_pixisopt[1]	
	3	iplwp	
	4	cfgwp	
	5	rp_cntrl	
	6	spare5	
	(7–8)	cfg_cfgopt[0:1]	Static

Table 21. Configuration Switches (continued)

Group	Switches	Configuration Signals	Class
SW10	(1–2)	zl_ca_v_sel[1:0]	Static
	(3–4)	zl_cb_v_sel[1:0]	
	(5–6)	zl_pl_v_sel[1:0]	
	7	n/a	—
	8	n/a	—

“Dynamic” are those configuration pins that are only asserted during $\overline{\text{HRESET}}$ (these are also processor-only configuration pins), while “Static” configuration pins remain constant as long as the system power is operational.

7 Programming Model

This section covers general programming information to help guide the writing of board support packages.

7.1 ngPIXIS Registers

The ngPIXIS device contains several software accessible registers that are accessed from the base address programmed for LCS3 (see [Section 5.1.5, “Local Bus”](#)). This table shows the register map of the ngPIXIS device.

Table 22. ngPIXIS Register Map

Base Address Offset	Register	Access	Reset	Section/Page
0x00	PX_ID—System ID register	R	0x17	7.1.1/46
0x01	PX_ARCH—System architecture version register	R	0x01	7.1.2/46
0x02	PX_SCVER—ngPIXIS version register	R	0x02	7.1.3/47
0x03	PX_CSR—General control/status register	R/W	All zeros	7.1.4/48
0x04	PX_RST—Reset control register	R/W	All zeros	7.1.5/48
0x05	Reserved	—	—	—
0x06	PX_AUX—Auxiliary register	R/W	All zeros	7.1.6/49
0x07	PX_SPD—Speed register	R	All zeros	7.1.7/50
0x08	PX_BRDCFG0—Board Configuration register 0	R/W	0x11	7.1.8/50
0x0A	PX_ADDR—SRAM Address Register	R/W	All zeros	7.1.9/51
0x0B–0x0C	Reserved	—	—	—
0x0D	PX_DATA—SRAM Data Register	R/W	Undefined	7.1.10/51
0x0E	PX_LED—LED Data Register	R/W	All zeros	7.1.11/52
0x0F	Reserved	—	—	—
0x10	PX_VCTL—VELA Control Register	R/W	All zeros	7.1.12/52

Table 22. ngPIXIS Register Map (continued)

Base Address Offset	Register	Access	Reset	Section/Page
0x11	PX_VSTAT—VELA Status Register	R	All zeros	7.1.13/53
0x13	Reserved	—	—	—
0x14	PX_OCMCSR—OCMCSR Register	R/W	All zeros	7.1.14/53
0x15	PX_OCMMSG—OCMMSG Register	R/W	All zeros	7.1.15/54
0x16	PX_GMDBG—GMDBG Register	R/W	All zeros	7.1.16/55
0x17–0x18	Reserved	—	—	—
0x19	PX_SCLK0—SCLK0 Register	R/W	varies	7.1.17/55
0x1A	PX_SCLK1—SCLK1 Register	R/W	Varies	7.1.17/55
0x1B	PX_SCLK2—SCLK2 Register	R/W	Varies	7.1.17/55
0x1F	PX_WATCH—WATCH Register	R/W	0x7F	7.1.18/55
0x20, 0x22, ...	PX_SW(1:8)—SW(1:8) Registers	R/W	All zeros	7.1.19/57
0x21, 0x23, ...	PX_EN(1:8)—EN(1:8) Registers	R/W	All zeros	7.1.20/57

7.1.1 ID Register (PX_ID)

The ID register (PX_ID) contains a unique classification number; this ID number is used by software to uniquely identify development boards. The ID number does not change for any P4080DS revision.

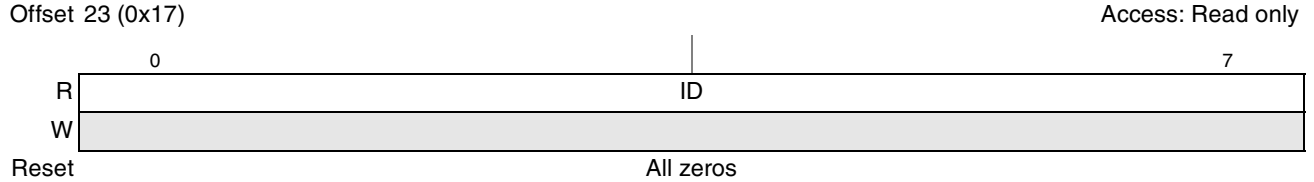

Figure 26. ID Register (PX_ID)

Table 23. PX_ID Field Descriptions

Bits	Name	Description
0–7	ID	Board identification

7.1.2 Architectural Version Register (PX_ARCH)

The architectural version register (PX_ARCH) contains the architectural revision of the P4080DS board.

This register only changes when significant (that is, software-visible and software-impacting) changes to the board have occurred; examples are replacing a component with a slot or eliminating a “backup” device. Conversely, changing Flash manufacturers, for example, would not be considered an architectural change, because a CFI-compliant Flash programmer should be able to handle such a change.

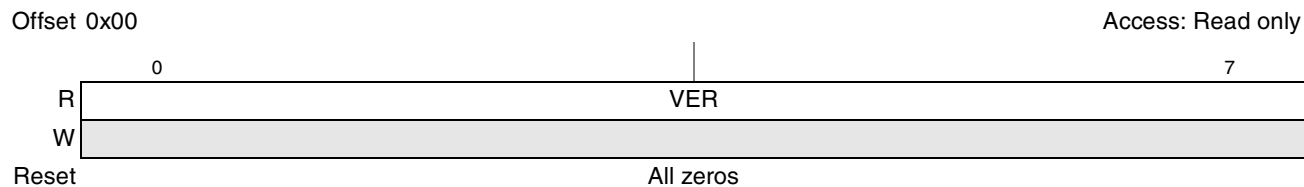

Figure 27. Architectural Version Register (PX_ARCH)

Table 24. PX_ARCH Field Descriptions

Bits	Name	Description
0–7	VER	Version number: %00000001 : Version 1 %00000010 : Version 2 And so on

7.1.3 System Control FPGA Version Register (PX_SCVER)

The system control FPGA version register (PX_SCVER) contains the major and minor revision information of the ngPIXIS system controller FPGA.

This register changes as features are added/updated within the FPGA, and is incremented as FPGA images are distributed. Because the FPGA image is (generally) designed to work on one or more board versions, there is no correlation between the two.

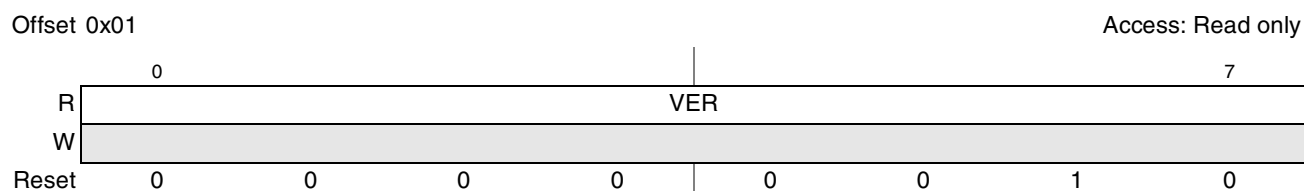

Figure 28. Version Register (PX_SCVER)

Table 25. PX_SCVER Field Descriptions

Bits	Name	Description
0–7	VER	Version number: %00000001 : Version 1 %00000010 : Version 2 And so on

7.1.4 General Control/Status Register (PX_CSR)

The general control/status register (PX_CSR) contains various control and status fields, as described below.

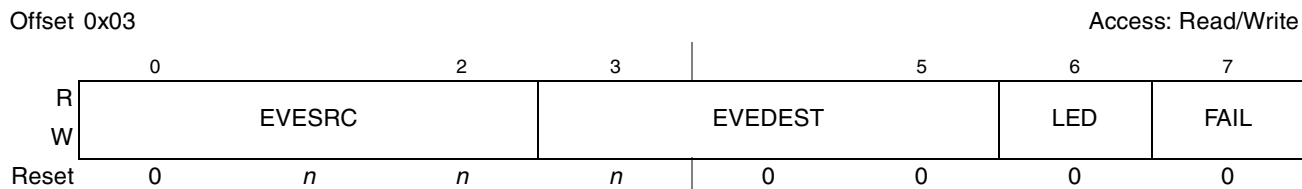

Figure 29. General Control/Status Register (PX_CSR)

Table 26. PX_CSR Field Descriptions

Bits	Name	Description
0–2	EVESRC	Selects one of several inputs for mapping to internal signal <i>esig</i> , which in turn may be connected to special outputs (see PIX_CSR[EVEDEST]). 000 <i>esig</i> <- event_b 001 <i>esig</i> <- trig_out 010 <i>esig</i> <- evt_b(2) 011 <i>esig</i> <- evt_b(3) 111 <i>esig</i> <- chkstpi_b
3–5	EVEDEST	Selects the output pin to which the internal signal <i>esig</i> is driven (see PIX_CSR[EVESRC] for details). 001 <i>esig</i> -> trig_in 010 <i>esig</i> -> evt_b(7) 011 <i>esig</i> -> evt_b(8) 100 <i>esig</i> -> evt_b(9)
6	LED	If set, the diagnostic LEDs are driven by the value in the PX_LED register; otherwise, the LEDs default to activity monitors
7	FAIL	If set, the external LED labeled “FAIL” is turned on and the one labeled “PASS” is off; otherwise, if cleared, the opposite is true.

7.1.5 Reset Control Register (PX_RST)

The reset control register (PX_RST) may be used to reset the system, or portions of it.



Figure 30. Reset Control Register (PX_RST)

Table 27. PX_RST Field Descriptions

Bits	Name	Description
0	ALL	Allows the entire system to be reset. 0 A full system reset is initiated. 1 Normal operation.
1–3	—	Reserved
4	SXSLOT	Allows reset of any board installed in the SGMII/XAUI riser card slot. 0 SXSLOT_RST_B is asserted. 1 SXSLOT_RST_B is deasserted.
5	PHY	Allows reset of the 10/100/1G Ethernet PHY. 0 PHY_RST_B is asserted. 1 PHY_RST_B is deasserted
6	—	Reserved
7	GEN	Allows reset of miscellaneous board features (refer to schematics or documentation for details). 0 GEN_RST_B is asserted. 1 GEN_RST_B is deasserted

NOTE

PX_RST register bits are not self-resetting. PX_RST[ALL] is reset only as a side effect of triggering a full system reset. The other bits must be cleared with software.

NOTE

These register-based resets are merged with others internal resets, such as those of the VELA sequencer. Setting these bits while a VELA configuration cycle is active may have unpredictable results.

7.1.6 Auxiliary Register (PX_AUX)

The auxiliary register (PX_AUX) is a general-purpose read/write register. It reset upon initial power activation, or by chassis reset sources; PX_AUX preserves its value between Aurora-, COP- or watchdog-initiated resets.

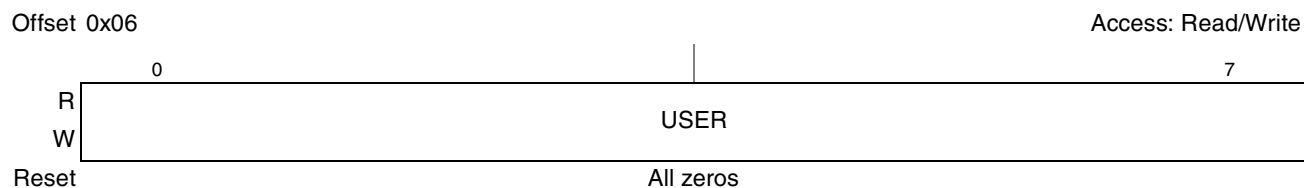
Figure 31. Auxiliary Register (PX_AUX)
Table 28. PX_AUX Field Descriptions

Bits	Name	Description
0–7	USER	User-defined

7.1.7 Speed Status Register (PX_SPD)

The speed status register (PX_SPD) is used to communicate the current switch-selectable settings for the SYSCLK clock generator, one of eight preset values. This register is typically needed for software to be able to accurately initialize timing-dependent parameters, such as those for local bus, DDR memory, I²C clock rates, and more.

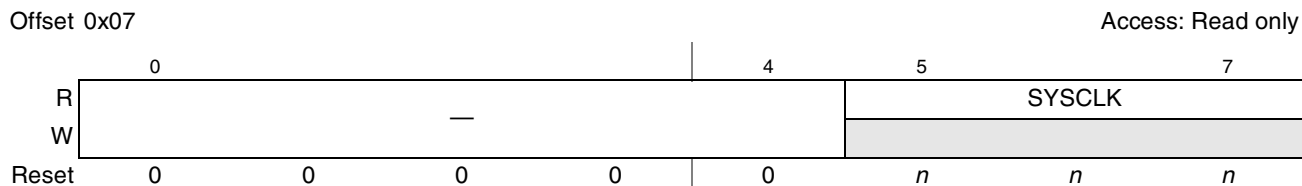

Figure 32. Speed Status Register (PX_SPD)

Table 29. PX_SPD Field Descriptions

Bits	Name	Description
0–4	—	Reserved
5–7	SYSCLK	Reflects switch settings as described in Table 16 .

7.1.8 Board Configuration Register (PX_BRDCFG0)

The board configuration register (PX_BRDCFG0) controls the board configuration. Unlike other configuration settings, those controlled by this register may be changed at any time.

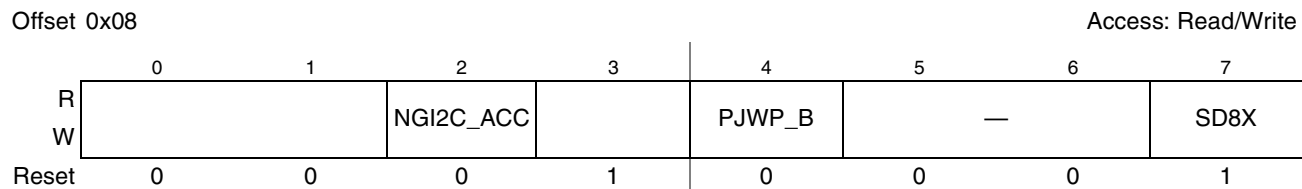

Figure 33. Board Configuration Register 0 (PX_BRDCFG0)

Table 30. PX_BRDCFG0 Field Descriptions

Bits	Name	Description
0–1	—	Reserved
2	NGI2C_ACC	Controls the whether the system may access the private I ² C devices owned by the ngPIXIS device. 0 The system cannot access those devices. 1 The system may access those devices.
3	—	Reserved
4	PJWP_B	Controls whether the PromJET may be written to or not. 0 The PromJet cannot be written to. 1 The PromJet may be written to.

Table 30. PX_BRDCFG0 Field Descriptions (continued)

Bits	Name	Description
5–6	—	Reserved
7	SD8X	0 P4080 SPI_CS(0:3)_B pins are used as SDHC data bits 4:7 for SDHC-8bit mode. SPI CS_B pins are pulled high. 1 P4080 SPI_CS(0:3)_B pins are used with the SPI controller. SDHC data bits 4:7 are pulled high and only SDHC 4-bit mode is used.

7.1.9 SRAM Address Register (PX_ADDR)

The SRAM address register (PX_ADDR) is a general-purpose register that is used to index an internal 256-byte SRAM array. Though reset upon initial power activation or by chassis reset sources, PX_ADDR preserves its value between COP- or watchdog-initiated resets.

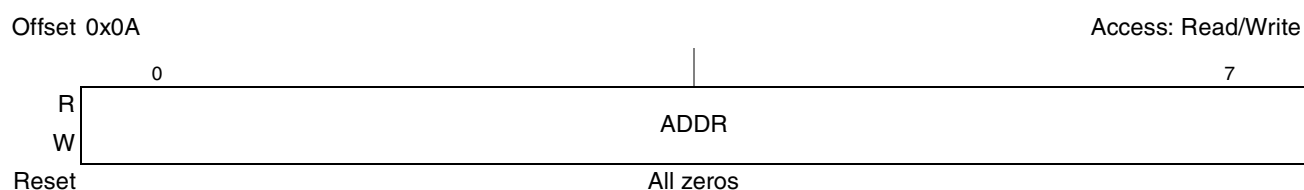
Figure 34. SRAM Address Register (PX_ADDR)
Table 31. PX_ADDR Field Descriptions

Bits	Name	Description
0–7	ADDR	Address of SRAM array to which PX_DATA reads/writes.

NOTE

Writing PX_ADDR and reading/write PX_DATA is non-atomic. Care should be exercised when sharing SRAM between processors and/or the ngPIXIS GMSA core.

7.1.10 Data Register (PX_DATA)

The data register (PX_DATA) is a general-purpose register that is used to read or write to an internal 256-byte SRAM array. Though reset upon initial power activation or by chassis reset sources, PX_DATA preserves its value between COP- or watchdog-initiated resets.

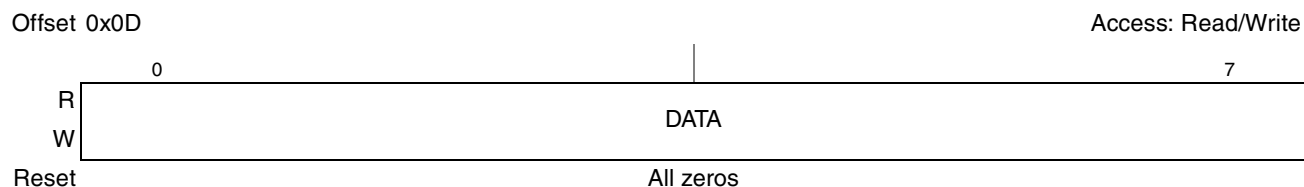

Figure 35. Data Register (PX_DATA)

Table 32. PX_DATA Field Descriptions

Bits	Name	Description
0–7	DATA	Contents of SRAM array as indexed by PX_ADDR

7.1.11 LED Data Register (PX_LED)

The LED data register (PX_LED) can be used to directly control the monitoring LEDs (for software message purposes, as an example). Direct control of the LEDs is possible only when PX_CSR[LED] is set to 1.

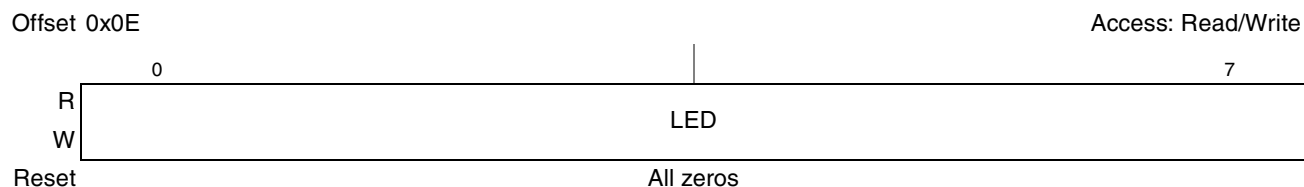

Figure 36. LED Data Register (PX_LED)

Table 33. PX_LED Field Descriptions

Bits	Name	Description
0–7	LED	Corresponding values for monitoring LEDs L0–L7. 0 Does not illuminate the LED 1 Illuminates the LED

7.1.12 VELA Control Register (PX_VCTL)

The VELA control register (PX_VCTL) may be used to start and control the configuration reset sequencer as well as other configuration/test-related features.



Figure 37. VELA Control Register (PX_VCTL)

Table 34. PX_VCTL Field Descriptions

Bits	Name	Description
0–3	—	Reserved
4	WDEN	Watchdog enable 0 Watchdog disabled 1 Watchdog enabled. If not disabled with 2 ²⁹ clock cycles (> 5 minutes at 30-ns clock), the system is reset. Note: This is not a highly secure watchdog; software can reset this bit at any time, disabling the watchdog.

Table 34. PX_VCTL Field Descriptions (continued)

Bits	Name	Description
5	—	Reserved
6	PWROFF	Power off 0 Power is controlled as normal (by NVidia or by switch). 1 Power is forced off. Note: Hardware must restore power; software cannot force power on. Note: Note that the default value of PWROFF is zero, so that normal operations do not interfere with the power switches. Setting PWROFF to 1 overrides any user- or APM-initiated power switch event.
7	GO	Go 0 The VELA sequencer remains idle. 1 The VELA sequencer starts. Note: The sequencer halts after running until software resets GO to 0.

7.1.13 VELA Status Register (PX_VSTAT)

The VELA status register (PX_VSTAT) may be used to monitor the configuration sequencer activity.

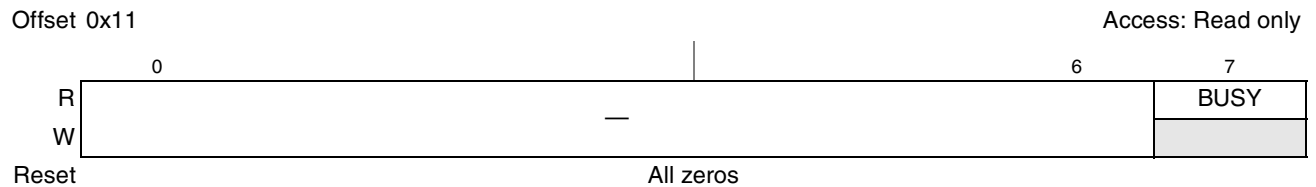

Figure 38. VELA Status Register (PX_VSTAT)

Table 35. PX_VSTAT Field Descriptions

Bits	Name	Description
0–6	—	Reserved
7	BUSY	0 The VELA sequencer is idle. 1 The VELA sequencer is busy.

7.1.14 OCM Control/Status Register (PX_OCMCSR)

The OCM control/status register (PX_OCMCSR) is a general-purpose register used to communicate between the P4080 and the FPGA GMSA processor.

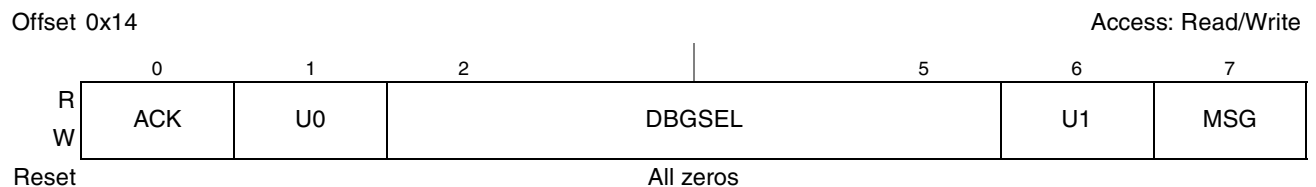

Figure 39. OCM Control/Status Register (PX_OCMCSR)

Table 36. PX_OCMCSR Field Descriptions

Bits	Name	Description
0	ACK	0 No acknowledgement is present. 1 OCM software signals that a message has been processed.
1	U0	Unassigned values
2–5	DBGSEL	Selects information to provide in the GMDBG register.
6	U1	Unassigned values
7	MSG	0 No message is present. 1 Signals OCM software that a message is present.

Note: Field descriptions are enforced by software; it is possible to redefine the meanings by using different software in the GMSA processor.

7.1.15 OCM Message Register (PX_OCMMSG)

The OCM message register (PX_OCMMSG) is a general-purpose register used to communicate between the P4080 and the FPGA GMSA processor.

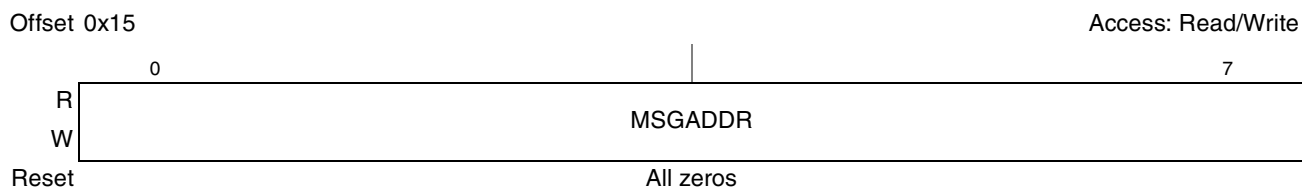

Figure 40. OCM Message Register (PX_OCMMSG)

Table 37. PX_OCMMSG Field Descriptions

Bits	Name	Description
0–7	ADDR	Address within shared SRAM of a message to process

Note: The above definitions are enforced by software; it is possible to redefine the meanings by using different software in the GMSA processor.

Note: The above definitions are enforced by software; it is possible to redefine the meanings by using different software in the GMSA processor.

7.1.16 GMSA Debug Register (PX_GMDBG)

The GMSA debug register (PX_GMDBG) allows access to information regarding the GMSA processor in the ngPIXIS.

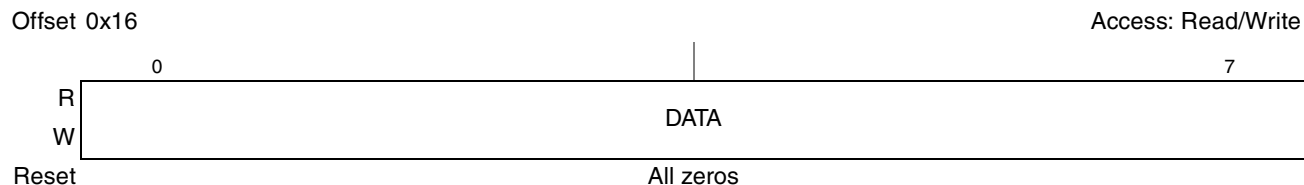

Figure 41. GMSA Debug Register (PX_GMDBG)

Table 38. PX_GMDBG Field Descriptions

Bits	Name	Description
0–7	DATA	Requested data, as selected by PX_OCMCSR[2:5] 0001 PC[7:0] 0010 PC[11:0] 0011 opcode 0100 status 0101 TOS Other values are undefined.

7.1.17 SCLK[0:2] Registers (PX_SCLK[0:2])

The PX_SCLK[0:2] registers control the 24-bit configuration word of the ICS307 system clock generator.

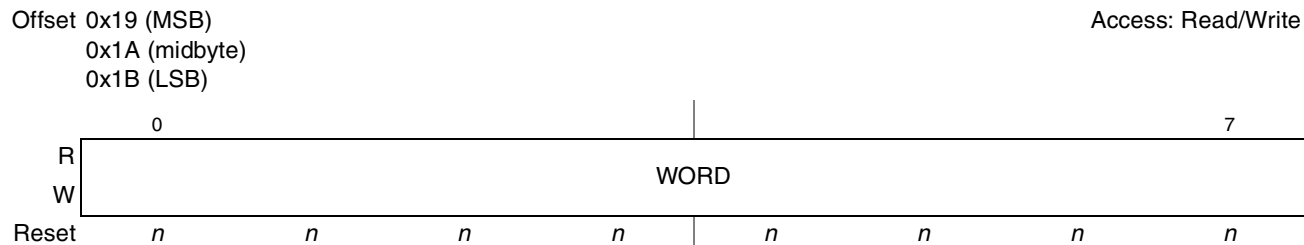

Figure 42. SCLK[0:2] Register (PX_SCLK[0:2])

Table 39. PX_SCLK[0:2] Field Descriptions

Bits	Name	Description
0–7	WORD	Read: Returns the current programmed values Write: Values written to WORD are driven into the ICS307 during reset sequencing if PX_VCFGEN0[SCLK]=1; otherwise, the encoded value of CFG_SYSClk(0:2) is used.

7.1.18 Watchdog Register (PX_WATCH)

The watchdog register (PX_WATCH) selects the appropriate watchdog timer event for the VELA-controlled sequencer. Note that this watchdog works independently of any other watchdog timers, such as those within the P4080.

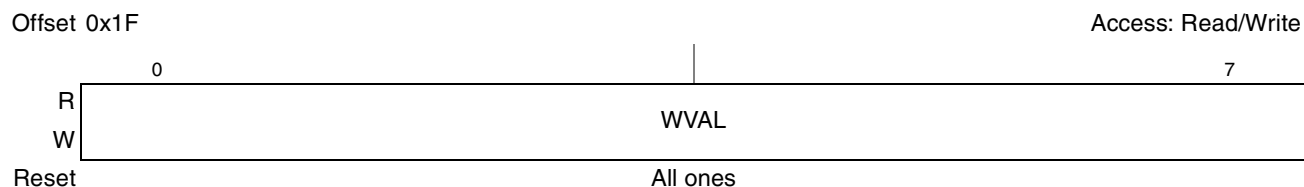

Figure 43. Watchdog Register (PX_WATCH)

Table 40. PX_WATCH Field Descriptions

Bits	Name	Description
0–7	WVAL	Read: Returns the current programmed values. Write: Sets watchdog timer.

NOTE

The PX_WATCH register represents the 8 most significant bits of an internal 34-bit watchdog timer. Any new value must be written before the PX_VCTL[WDEN] bit is set to 1, and must be written after every reset of this register (that is, it resets just like any other general register). If the watchdog times out or any other reset/restart condition occurs (except the PX_VCTL[GO] bit), then repeat the procedure.

Time formulae:

The base of the timer = 26 bits x 30 ns interval = 2.01326592 seconds.

Where the upper 8 bits represent (seconds) [(decimal value of the 8-bit field) x (2.01326592sec)] + 2.01326592sec

Some examples values for PX_WATCH register values are shown in [Table 41](#).

Table 41. Watchdog Timer Values

Timeout Value		Timeout
Binary	Hex	
11111111	0xFF	0.59 min
01111111	0x7F	4.29 min
00111111	0x3F	2.15min
00011111	0x1F	1.07 min
00001111	0x0F	32.1 sec
00000111	0x07	16.1 sec
00000011	0x03	8.05 sec
00000001	0x01	4.027 sec
00000000	0x00	2.013 sec

7.1.19 Switch Registers (PX_SWx)

The switch registers (PX_SWx) are used to define configuration switch overrides. Each bit in each PX_SWx register corresponds to a similarly named switch on the board. If a bit is 1, the switch is 1 and vice-versa, provided the matching ENx bit is set.



Figure 44. Switch Registers (PX_SWx)

Table 42. PX_SWx Field Descriptions

Bits	Name	Description
0–7	SWx #b	Value to replace for switch SWx #b.

Note that SW registers do NOT reflect the contents of the physical switches.

7.1.20 Switch Enable Registers (PX_ENx)

The switch enable register (PX_ENx) control whether the corresponding bits of the corresponding PX_SWx register are used or ignored.



Figure 45. Switch Enable Register (PX_ENx)

Table 43. PX_ENx Field Descriptions

Bits	Name	Description
0–7	ENx #b	0 External switch SWx #b controls the corresponding configuration pin; the system controller does not affect the value. 1 Internal register SWx #b controls the corresponding configuration pin; the external switches do not affect the value.

7.2 EEPROM Data

The SystemID EEPROM stores important data about the Expedition system, including the following:

- Board ID
- Errata level (as shipped)
- Manufacturing date

Revision History

- Ethernet MAC address

This device is programmed at the factory and is write-protected. The contents of the data are described in detail in application note *The SystemID Format for Power Architecture® Development Systems (AN3638)* available at the freescale.com website.

8 Revision History

This table provides a revision history for this document.

Table 44. Document Revision History

Rev. Number	Date	Substantive Change(s)
0	07/2011	Initial public release

Appendix A References

This table lists useful reference documents.

Table A-1. Useful References

Topic	Reference
System design	<i>P4080 QorIQ Integrated Processor Hardware Specifications (P4080EC)</i>
SoC programming	<i>P4080 QorIQ Integrated Multicore Communication Processor Family Reference Manual (P4080RM)</i>
Switch configuration	P4080DS Configuration Sheet
SystemID format	<i>The SystemID Format for Power Architecture™ Development Systems (AN3638)</i>
PromJet	PromJet modules are flash memory emulators available from Emutech (www.emutech.com). Expedition uses the 16-bit wide devices (size is user-dependent). The “low-voltage” option for use on the 3.3 V local bus.

How to Reach Us:

Home Page:

www.freescale.com

Web Support:

<http://www.freescale.com/support>

USA/Europe or Locations Not Listed:

Freescale Semiconductor, Inc.
Technical Information Center, EL516
2100 East Elliot Road
Tempe, Arizona 85284
1-800-521-6274 or
+1-480-768-2130
www.freescale.com/support

Europe, Middle East, and Africa:

Freescale Halbleiter Deutschland GmbH
Technical Information Center
Schatzbogen 7
81829 Muenchen, Germany
+44 1296 380 456 (English)
+46 8 52200080 (English)
+49 89 92103 559 (German)
+33 1 69 35 48 48 (French)
www.freescale.com/support

Japan:

Freescale Semiconductor Japan Ltd.
Headquarters
ARCO Tower 15F
1-8-1, Shimo-Meguro, Meguro-ku
Tokyo 153-0064
Japan
0120 191014 or
+81 3 5437 9125
support.japan@freescale.com

Asia/Pacific:

Freescale Semiconductor China Ltd.
Exchange Building 23F
No. 118 Jianguo Road
Chaoyang District
Beijing 100022
China
+86 10 5879 8000
support.asia@freescale.com

For Literature Requests Only:

Freescale Semiconductor
Literature Distribution Center
1-800 441-2447 or
+1-303-675-2140
Fax: +1-303-675-2150
LDCForFreescaleSemiconductor@hibbertgroup.com

Information in this document is provided solely to enable system and software implementers to use Freescale Semiconductor products. There are no express or implied copyright licenses granted hereunder to design or fabricate any integrated circuits or integrated circuits based on the information in this document.

Freescale Semiconductor reserves the right to make changes without further notice to any products herein. Freescale Semiconductor makes no warranty, representation or guarantee regarding the suitability of its products for any particular purpose, nor does Freescale Semiconductor assume any liability arising out of the application or use of any product or circuit, and specifically disclaims any and all liability, including without limitation consequential or incidental damages. "Typical" parameters which may be provided in Freescale Semiconductor data sheets and/or specifications can and do vary in different applications and actual performance may vary over time. All operating parameters, including "Typicals" must be validated for each customer application by customer's technical experts. Freescale Semiconductor does not convey any license under its patent rights nor the rights of others. Freescale Semiconductor products are not designed, intended, or authorized for use as components in systems intended for surgical implant into the body, or other applications intended to support or sustain life, or for any other application in which the failure of the Freescale Semiconductor product could create a situation where personal injury or death may occur. Should Buyer purchase or use Freescale Semiconductor products for any such unintended or unauthorized application, Buyer shall indemnify and hold Freescale Semiconductor and its officers, employees, subsidiaries, affiliates, and distributors harmless against all claims, costs, damages, and expenses, and reasonable attorney fees arising out of, directly or indirectly, any claim of personal injury or death associated with such unintended or unauthorized use, even if such claim alleges that Freescale Semiconductor was negligent regarding the design or manufacture of the part.

Freescale, the Freescale logo, CodeWarrior, ColdFire, PowerQUICC, QorIQ, StarCore, and Symphony are trademarks of Freescale Semiconductor, Inc., Reg. U.S. Pat. & Tm. Off. CoreNet, QorIQ Qonverge, QUICC Engine, and VortiQa are trademarks of Freescale Semiconductor, Inc. All other product or service names are the property of their respective owners. The Power Architecture and Power.org word marks and the Power and Power.org logos and related marks are trademarks and service marks licensed by Power.org.

© 2011 Freescale Semiconductor, Inc.

Document Number: P4080DSUG

Rev. 0
07/2010





Стандарт Электрон Связь

Мы молодая и активно развивающаяся компания в области поставок электронных компонентов. Мы поставляем электронные компоненты отечественного и импортного производства напрямую от производителей и с крупнейших складов мира.

Благодаря сотрудничеству с мировыми поставщиками мы осуществляем комплексные и плановые поставки широчайшего спектра электронных компонентов.

Собственная эффективная логистика и склад в обеспечивает надежную поставку продукции в точно указанные сроки по всей России.

Мы осуществляем техническую поддержку нашим клиентам и предпродажную проверку качества продукции. На все поставляемые продукты мы предоставляем гарантию .

Осуществляем поставки продукции под контролем ВП МО РФ на предприятия военно-промышленного комплекса России , а также работаем в рамках 275 ФЗ с открытием отдельных счетов в уполномоченном банке. Система менеджмента качества компании соответствует требованиям ГОСТ ISO 9001.

Минимальные сроки поставки, гибкие цены, неограниченный ассортимент и индивидуальный подход к клиентам являются основой для выстраивания долгосрочного и эффективного сотрудничества с предприятиями радиоэлектронной промышленности, предприятиями ВПК и научно-исследовательскими институтами России.

С нами вы становитесь еще успешнее!

Наши контакты:

Телефон: +7 812 627 14 35

Электронная почта: sales@st-electron.ru

Адрес: 198099, Санкт-Петербург,
Промышленная ул, дом № 19, литера Н,
помещение 100-Н Офис 331