

# RF Power LDMOS Transistors

## High Ruggedness N-Channel Enhancement-Mode Lateral MOSFETs

Designed for mobile two-way radio applications with frequencies from 764 to 941 MHz. The high gain, ruggedness and broadband performance of these devices make them ideal for large-signal, common source amplifier applications in mobile radio equipment.

### Narrowband Performance

(In Freescale Test Circuit: 12.5 Vdc,  $I_{DQ(A+B)} = 550$  mA,  $T_A = 25^\circ\text{C}$ , CW)

Frequency (MHz)	$G_{ps}$ (dB)	$\eta_D$ (%)	$P_{out}$ (W)
870	17.5	69.0	57

### 800 MHz Broadband Performance

(In Freescale Reference Circuit: 12.5 Vdc,  $I_{DQ(A+B)} = 800$  mA,  $P_{in} = 1.5$  W,  $T_A = 25^\circ\text{C}$ , CW)

Frequency (MHz)	$G_{ps}$ (dB)	$\eta_D$ (%)	$P_{out}$ (W)
764	16.1	56.0	61
816	15.8	58.0	57
870	15.7	61.0	56

### Load Mismatch/Ruggedness

Frequency (MHz)	Signal Type	VSWR	$P_{in}$ (W)	Test Voltage	Result
870 (1)	CW	>65:1 at all Phase Angles	3 (3 dB Overdrive)	17	No Device Degradation

1. Measured in 764-870 MHz broadband test circuit.

### Features

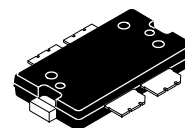
- Characterized for Operation from 764 to 941 MHz
- Integrated Input Matching Improves Broadband Performance
- Integrated ESD Protection
- Broadband — Full Power Across the Band (764-870 MHz)
- 225°C Capable Plastic Package
- Exceptional Thermal Performance
- Extreme Ruggedness
- High Linearity for: TETRA, SSB
- Cost-effective Over-molded Plastic Packaging
- In Tape and Reel. R1 Suffix = 500 Units, 44 mm Tape Width, 13-inch Reel.

### Typical Applications

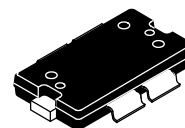
- Output Stage 800 MHz Band Mobile Radio
- Output Stage 700 MHz Band Mobile Radio

**AFT09MP055NR1**  
**AFT09MP055GNR1**

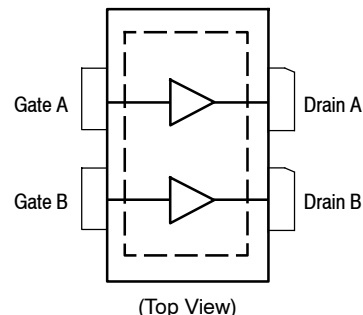
**764-941 MHz, 55 W, 12.5 V  
BROADBAND  
RF POWER LDMOS TRANSISTORS**



**TO-270WB-4  
AFT09MP055NR1**



**TO-270WB-4 GULL  
AFT09MP055GNR1**



Note: Exposed backside of the package is the source terminal for the transistor.

**Figure 1. Pin Connections**

**Table 1. Maximum Ratings**

Rating	Symbol	Value	Unit
Drain-Source Voltage	$V_{DSS}$	-0.5, +40	Vdc
Gate-Source Voltage	$V_{GS}$	-6.0, +12	Vdc
Operating Voltage	$V_{DD}$	19, +0	Vdc
Storage Temperature Range	$T_{stg}$	-65 to +150	°C
Case Operating Temperature Range	$T_C$	-40 to +150	°C
Operating Junction Temperature Range (1,2)	$T_J$	-40 to +225	°C
Total Device Dissipation @ $T_C = 25^\circ\text{C}$ Derate above $25^\circ\text{C}$	$P_D$	625 3.13	W W/°C

**Table 2. Thermal Characteristics**

Characteristic	Symbol	Value (2,3)	Unit
Thermal Resistance, Junction to Case Case Temperature $78^\circ\text{C}$ , 55 W CW, 12.5 Vdc, $I_{DQ(A+B)} = 550$ mA, 870 MHz	$R_{\theta JC}$	0.32	°C/W

**Table 3. ESD Protection Characteristics**

Test Methodology	Class
Human Body Model (per JESD22-A114)	2, passes 2500 V
Machine Model (per EIA/JESD22-A115)	A, passes 150 V
Charge Device Model (per JESD22-C101)	IV, passes 2000 V

**Table 4. Moisture Sensitivity Level**

Test Methodology	Rating	Package Peak Temperature	Unit
Per JESD22-A113, IPC/JEDEC J-STD-020	3	260	°C

**Table 5. Electrical Characteristics** ( $T_A = 25^\circ\text{C}$  unless otherwise noted)

Characteristic	Symbol	Min	Typ	Max	Unit
<b>Off Characteristics</b>					
Zero Gate Voltage Drain Leakage Current ( $V_{DS} = 40$ Vdc, $V_{GS} = 0$ Vdc)	$I_{DSS}$	—	—	3	$\mu\text{A}$ dc
Zero Gate Voltage Drain Leakage Current ( $V_{DS} = 12.5$ Vdc, $V_{GS} = 0$ Vdc)	$I_{DSS}$	—	—	2	$\mu\text{A}$ dc
Gate-Source Leakage Current ( $V_{GS} = 5$ Vdc, $V_{DS} = 0$ Vdc)	$I_{GSS}$	—	—	1	$\mu\text{A}$ dc
<b>On Characteristics</b>					
Gate Threshold Voltage ( $V_{DS} = 10$ Vdc, $I_D = 270$ $\mu\text{A}$ dc)	$V_{GS(th)}$	1.6	2.1	2.6	Vdc
Drain-Source On-Voltage ( $V_{GS} = 10$ Vdc, $I_D = 2.85$ Adc)	$V_{DS(on)}$	—	0.14	—	Vdc
Forward Transconductance (4) ( $V_{GS} = 10$ Vdc, $I_D = 7.5$ Adc)	$g_{fs}$	—	7	—	S

1. Continuous use at maximum temperature will affect MTTF.
2. MTTF calculator available at <http://www.freescale.com/rf>. Select Software & Tools/Development Tools/Calculators to access MTTF calculators by product.
3. Refer to AN1955, *Thermal Measurement Methodology of RF Power Amplifiers*. Go to <http://www.freescale.com/rf>. Select Documentation/Application Notes - AN1955.
4. Each side of device measured separately.

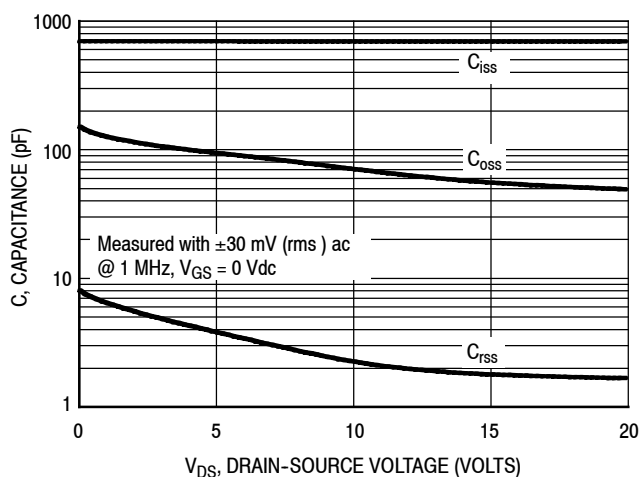
(continued)

**Table 5. Electrical Characteristics** ( $T_A = 25^\circ\text{C}$  unless otherwise noted) (continued)

Characteristic	Symbol	Min	Typ	Max	Unit
<b>Dynamic Characteristics</b> <sup>(1)</sup>					
Reverse Transfer Capacitance ( $V_{DS} = 12.5\text{ Vdc} \pm 30\text{ mV(rms)ac}$ @ 1 MHz, $V_{GS} = 0\text{ Vdc}$ )	$C_{rss}$	—	1.9	—	pF
Output Capacitance ( $V_{DS} = 12.5\text{ Vdc} \pm 30\text{ mV(rms)ac}$ @ 1 MHz, $V_{GS} = 0\text{ Vdc}$ )	$C_{oss}$	—	61	—	pF
Input Capacitance ( $V_{DS} = 12.5\text{ Vdc}$ , $V_{GS} = 0\text{ Vdc} \pm 30\text{ mV(rms)ac}$ @ 1 MHz)	$C_{iss}$ <sup>(2)</sup>	—	690	—	pF
<b>Functional Tests</b> <sup>(3)</sup> (In Freescale Narrowband Test Fixture, 50 ohm system) $V_{DD} = 12.5\text{ Vdc}$ , $I_{DQ(A+B)} = 550\text{ mA}$ , $P_{in} = 1\text{ W}$ , $f = 870\text{ MHz}$					
Common-Source Amplifier Output Power	$P_{out}$	—	57	—	W
Drain Efficiency	$\eta_D$	—	69.0	—	%

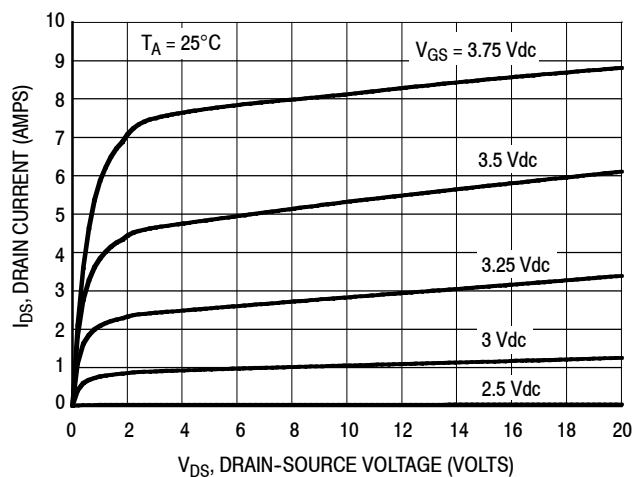
1. Each side of device measured separately.
2. Value includes input matching network.
3. Measurement made with device in straight lead configuration before any lead forming operation is applied. Lead forming is used for gull wing (GN) parts.

### TYPICAL CHARACTERISTICS



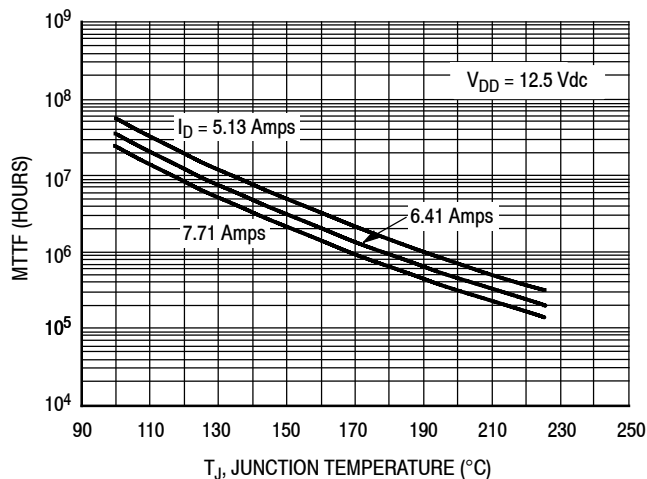
**Note:** Each side of device measured separately.  
 $C_{iss}$  value includes input matching network.

**Figure 2. Capacitance versus Drain-Source Voltage**



**Note:** Measured with both sides of the transistor tied together.

**Figure 3. Drain Current versus Drain-Source Voltage**

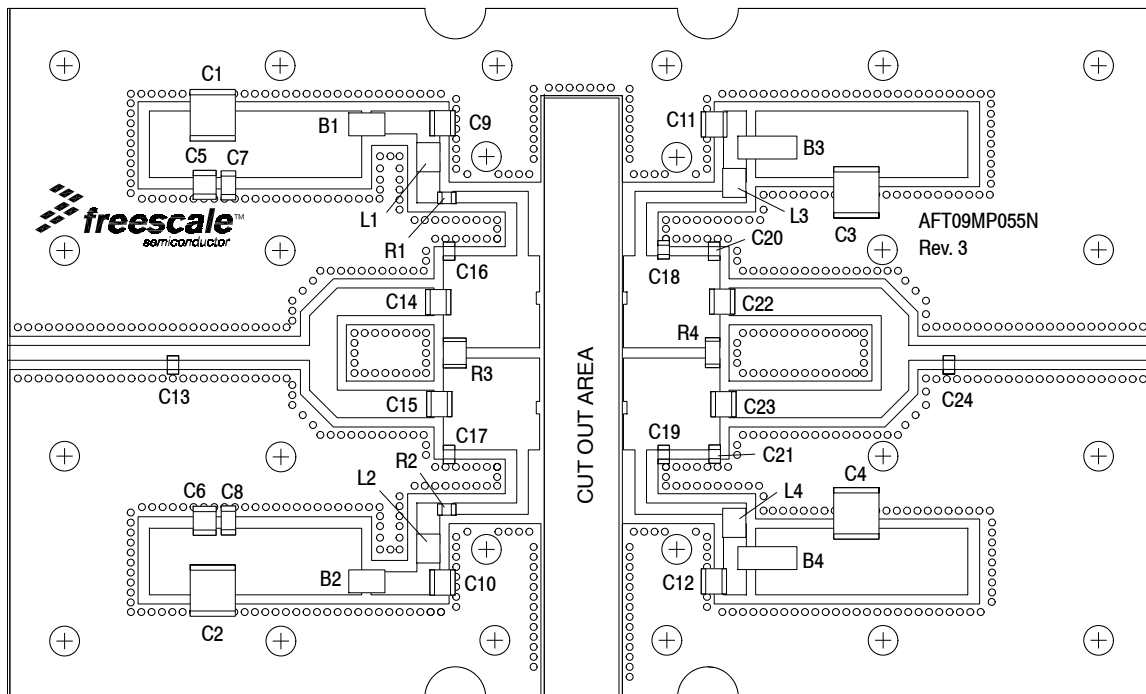


**Note:** MTTF value represents the total cumulative operating time under indicated test conditions.

MTTF calculator available at <http://www.freescale.com/rf>. Select Software & Tools/Development Tools/Calculators to access MTTF calculators by product.

**Figure 4. MTTF versus Junction Temperature - CW**

## 870 MHz NARROWBAND PRODUCTION TEST FIXTURE



**Figure 5. AFT09MP055NR1 Narrowband Test Circuit Component Layout — 870 MHz**

**Table 6. AFT09MP055NR1 Narrowband Test Circuit Component Designations and Values — 870 MHz**

Part	Description	Part Number	Manufacturer
B1, B2	RF Beads, Short	2743019447	Fair-Rite
B3, B4	RF Beads, Long	2743021447	Fair-Rite
C1, C2, C3, C4	10 $\mu$ F Chip Capacitors	GRM55DR61H106KA88L	Murata
C5, C6	0.1 $\mu$ F Chip Capacitors	GRM32MR71H104JA01L	Murata
C7, C8	1 $\mu$ F Chip Capacitors	GRM31MR71H105KA88L	Murata
C9, C10	68 pF Chip Capacitors	ATC100B680JT500XT	ATC
C11, C12, C22, C23	56 pF Chip Capacitors	ATC100B560CT500XT	ATC
C13	7.5 pF Chip Capacitor	GQM2195C2E7R5BB15	Murata
C14, C15	7.5 pF Chip Capacitors	ATC100B7R5CT500XT	ATC
C16, C17	12 pF Chip Capacitors	ATC600F120JT250XT	ATC
C18, C19, C20, C21	9.1 pF Chip Capacitors	GQM2195C2E9R1BB15	Murata
C24	3 pF Chip Capacitor	ATC600F3R0BT250XT	ATC
L1, L2, L3, L4	2.5 nH Inductors	A01TKLC	Coilcraft
R1, R2	10 $\Omega$ Chip Resistors	CRCW120610R0JNEA	Vishay
R3	2.0 $\Omega$ Chip Resistor	ERJ-14YJ2R0U	Panasonic
R4	5.9 $\Omega$ Chip Resistor	CRCW12065R90FKEA	Vishay
PCB	0.030", $\epsilon_r = 4.8$	RF35A2	Taconic

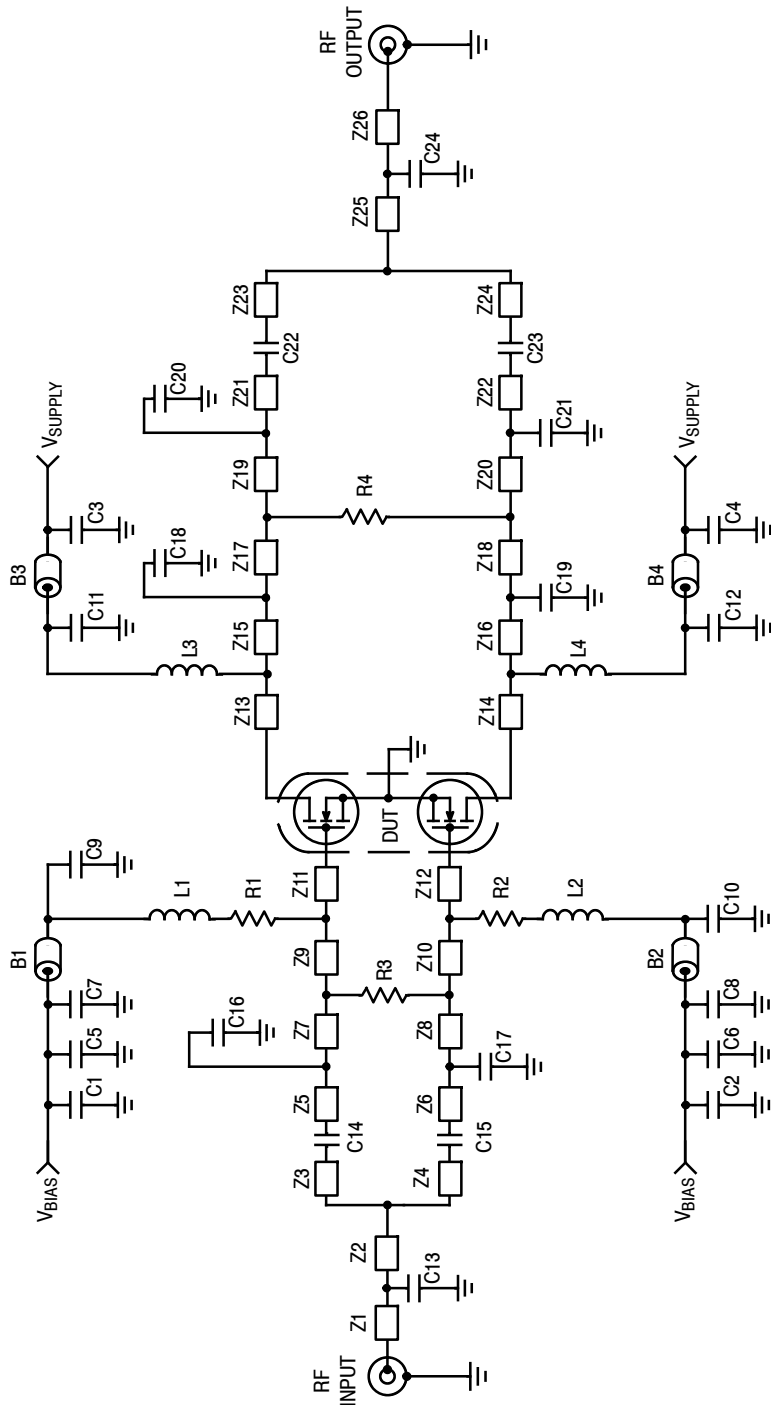


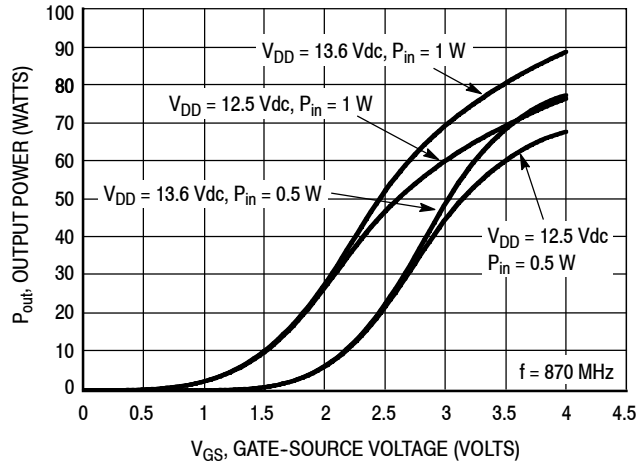
Figure 6. AFT09MP055NR1 Narrowband Test Circuit Schematic — 870 MHz

Table 7. AFT09MP055NR1 Narrowband Test Circuit Microstrips — 870 MHz

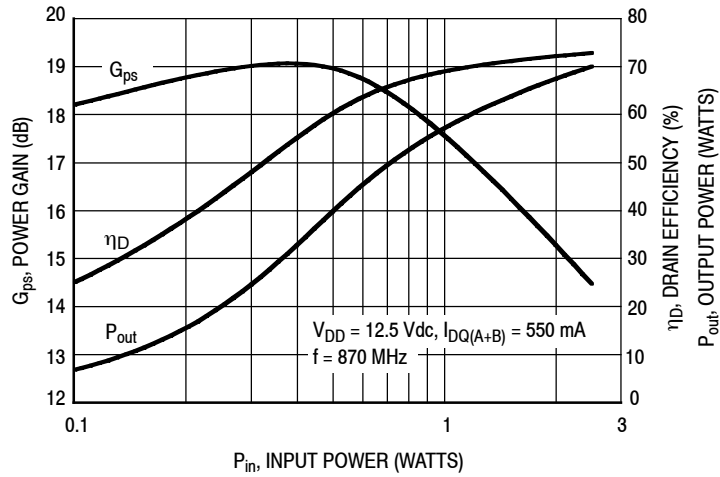
Microstrip	Description	Microstrip	Description	Microstrip	Description
Z1	0.721" x 0.065" Microstrip	Z9, Z10	0.295" x 0.400" Microstrip	Z19, Z20	0.007" x 0.400" Microstrip
Z2	0.595" x 0.065" Microstrip	Z11, Z12	0.075" x 0.400" Microstrip	Z21, Z22	0.025" x 0.400" Microstrip
Z3*, Z4*	0.670" x 0.120" Microstrip	Z13, Z14	0.075" x 0.400" Microstrip	Z23*, Z24*	0.885" x 0.120" Microstrip
Z5, Z6	0.025" x 0.400" Microstrip	Z15, Z16	0.100" x 0.400" Microstrip	Z25	0.175" x 0.065" Microstrip
Z7, Z8	0.025" x 0.400" Microstrip	Z17, Z18	0.213" x 0.400" Microstrip	Z26	0.901" x 0.065" Microstrip

\* Line length includes microstrip bends

### TYPICAL CHARACTERISTICS — 870 MHz



**Figure 7. Output Power versus Gate-Source Voltage at a Constant Input Power**



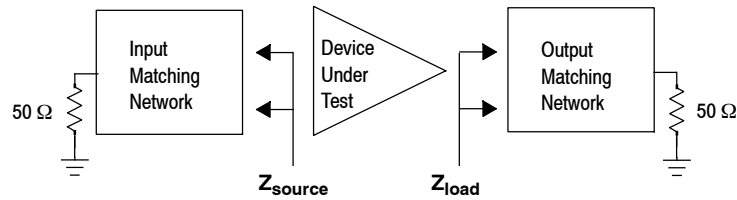
**Figure 8. Power Gain, Drain Efficiency and Output Power versus Input Power**

$V_{DD} = 12.5 \text{ Vdc}$ ,  $I_{DQ(A+B)} = 550 \text{ mA}$ ,  $P_{out} = 57 \text{ W Avg.}$

f MHz	$Z_{source}$ $\Omega$	$Z_{load}$ $\Omega$
870	$1.40 - j1.00$	$0.61 - j0.14$

$Z_{source}$  = Test circuit impedance as measured from gate to ground.

$Z_{load}$  = Test circuit impedance as measured from drain to ground.



**Figure 9. Narrowband Series Equivalent Source and Load Impedance — 870 MHz**

## 764-870 MHz BROADBAND REFERENCE CIRCUIT

**Table 8. 764-870 MHz Broadband Performance** (In Freescale Reference Circuit, 50 ohm system)

$V_{DD} = 12.5 \text{ Vdc}$ ,  $I_{DQ(A+B)} = 800 \text{ mA}$ ,  $P_{out} = 55 \text{ W}$ ,  $T_A = 25^\circ\text{C}$ , CW

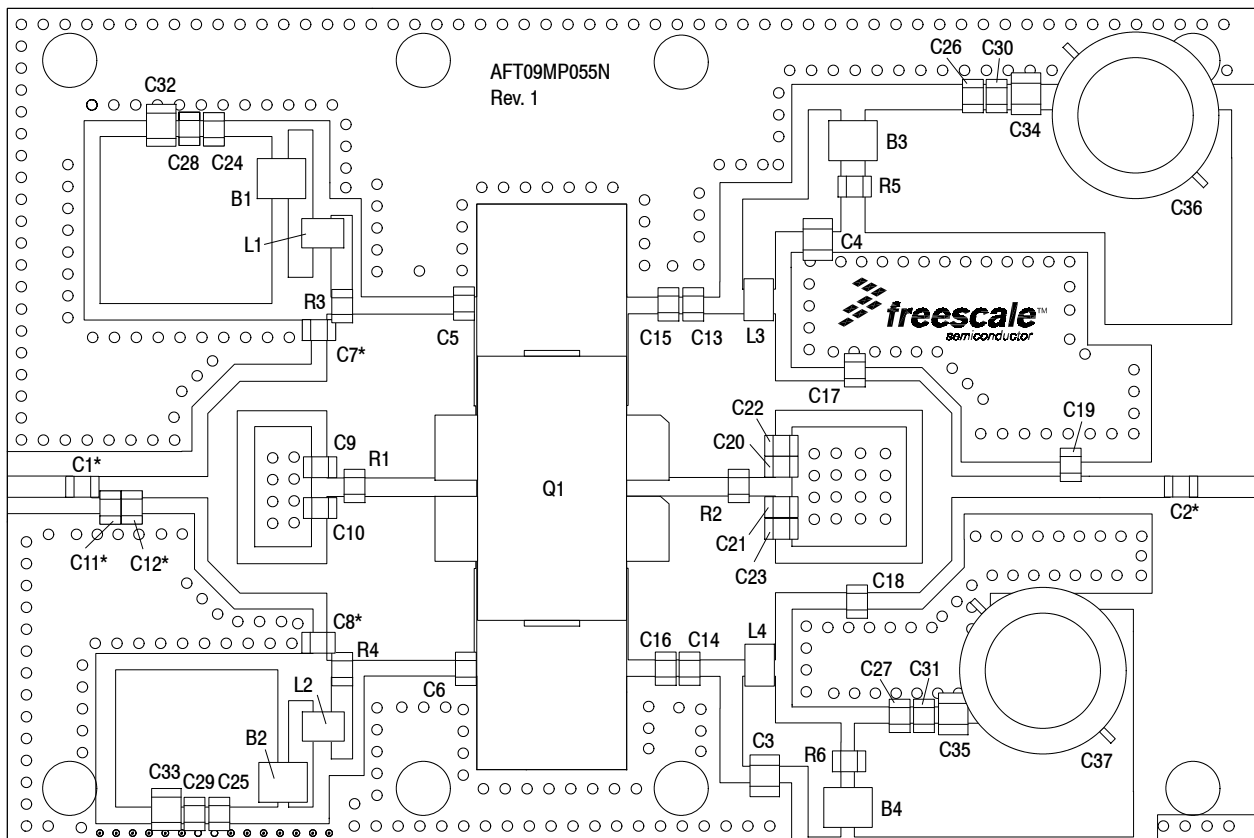
Frequency (MHz)	$G_{ps}$ (dB)	$\eta_D$ (%)	$P_{out}$ (W)
764	16.6	54.2	55
816	16.0	59.2	55
870	15.8	61.1	55

**Table 9. Load Mismatch/Ruggedness** (In Freescale Reference Circuit)

Frequency (MHz)	Signal Type	VSWR	$P_{in}$ (W)	Test Voltage, $V_{DD}$	Result
764	CW	>65:1 at all Phase Angles	3 (3 dB Overdrive)	15	No Device Degradation



## 764-870 MHz BROADBAND REFERENCE CIRCUIT



\*C1, C2, C7, C8, C11 and C12 are mounted vertically.

**Figure 10. AFT09MP055NR1 Broadband Reference Circuit Component Layout — 764-870 MHz**

**Table 10. AFT09MP055NR1 Broadband Reference Circuit Component Designations and Values — 764-870 MHz**

Part	Description	Part Number	Manufacturer
B1, B2, B3, B4	RF Beads, Short	2743019447	Fair-Rite
C1, C2, C3, C4	56 pF Chip Capacitors	ATC100B560GT1500XT	ATC
C5, C6, C7, C8	10 pF Chip Capacitors	ATC600F100GT250XT	ATC
C9, C10	8.2 pF Chip Capacitors	ATC600F8R2JT250XT	ATC
C11	4.7 pF Chip Capacitor	ATC600F4R7GT250XT	ATC
C12	5.6 pF Chip Capacitor	ATC600F5R6GT250XT	ATC
C13, C14	15 pF Chip Capacitors	ATC600F150JT250XT	ATC
C15, C16, C17, C18	3.9 pF Chip Capacitors	ATC600F3R9GT250XT	ATC
C19	6.8 pF Chip Capacitor	ATC600F6R8GT250XT	ATC
C20, C21	2.2 pF Chip Capacitors	ATC600F2R2GT250XT	ATC
C22, C23	1.5 pF Chip Capacitors	ATC600F1R5GT250XT	ATC
C24, C25, C26, C27	0.1 $\mu$ F Chip Capacitors	GRM32MR71H104JA01L	Murata
C28, C29, C30, C31	1 $\mu$ F Chip Capacitors	GRM31MR71H105KA88L	Murata
C32, C33, C34, C35	10 $\mu$ F Chip Capacitors	GRM55DR61H106KA88L	Murata
C36, C37	470 $\mu$ F, 63 V Electrolytic Capacitors	MCGPR63V477M13X26-RH	Multicomp
L1, L2, L3, L4	12.5 nH Chip Inductors	A04TKLC	Coilcraft
Q1	RF Power LDMOS Transistor	AFT09MP055NR1	Freescale
R1, R2, R3, R4, R5, R6	10 $\Omega$ , Chip Resistors	CRCW201010R0FKEF	Vishay
PCB	0.030", $\epsilon_r = 4.8$	S1000-2	Shengyi

**AFT09MP055NR1 AFT09MP055GNR1**

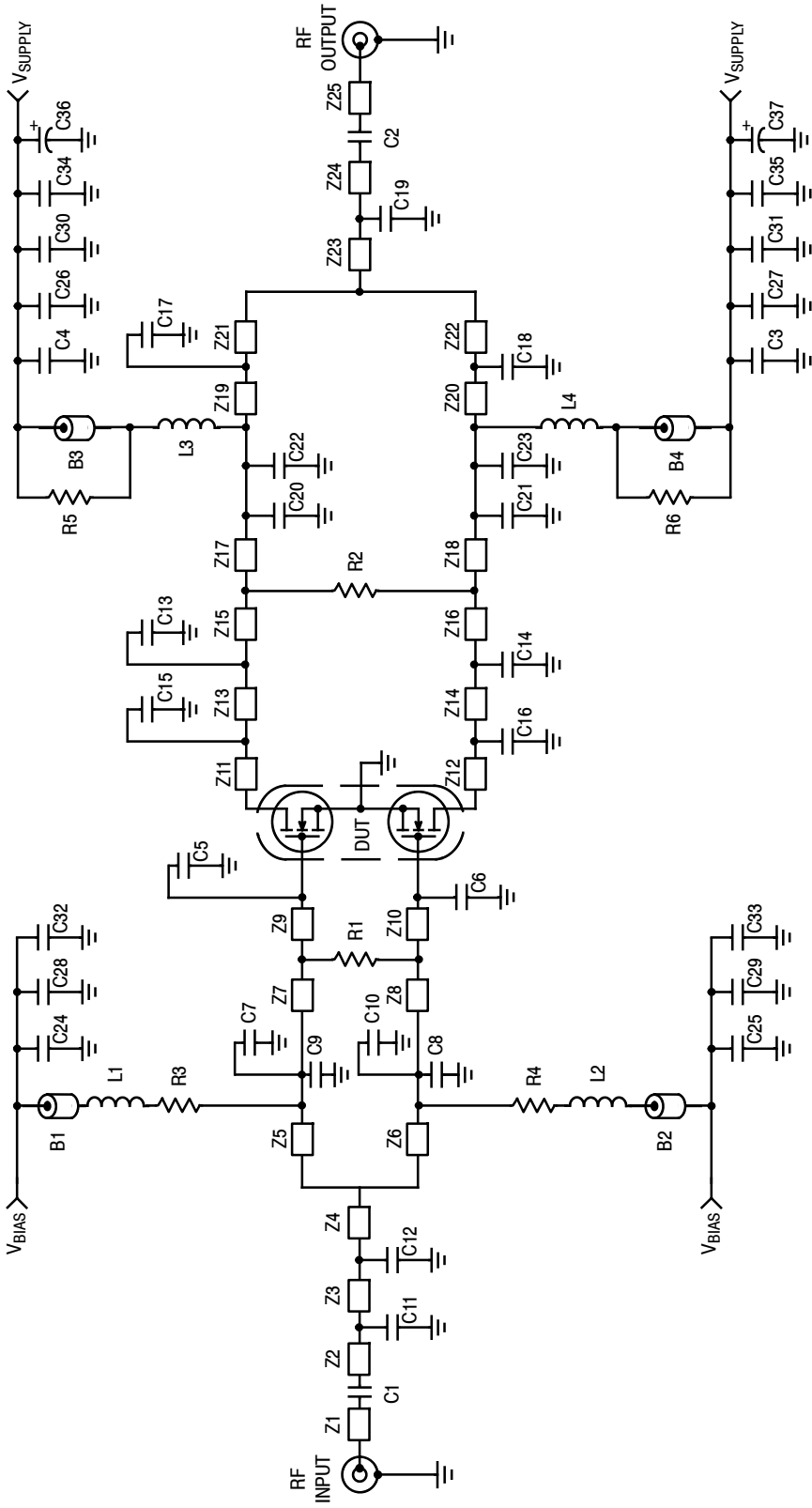


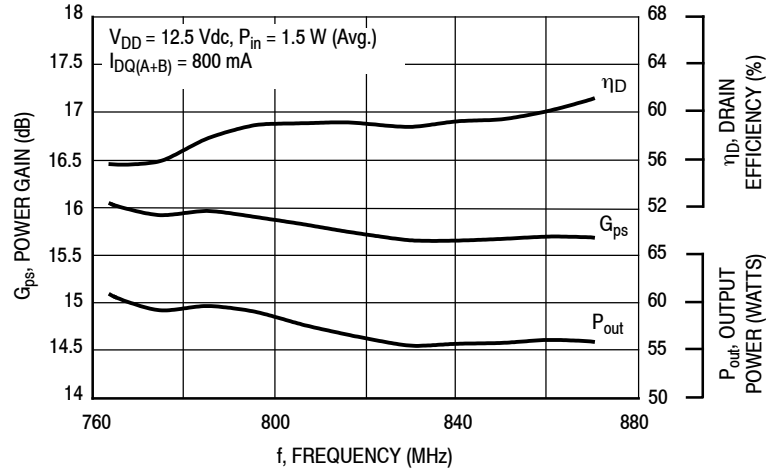
Figure 11. AFT09MP055NR1 Broadband Reference Circuit Schematic — 764-870 MHz

Table 11. AFT09MP055NR1 Broadband Reference Circuit Microstrips — 764-870 MHz

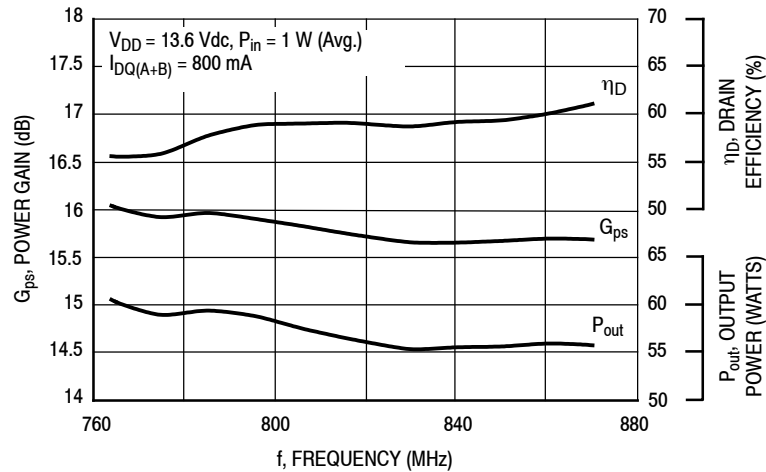
Microstrip	Description	Microstrip	Description	Microstrip	Description
Z1	0.157" x 0.051" Microstrip	Z9, Z10	0.319" x 0.393" Microstrip	Z19, Z20	0.190" x 0.071" Microstrip
Z2	0.043" x 0.051" Microstrip	Z11, Z12	0.097" x 0.393" Microstrip	Z21*, Z22*	0.500" x 0.071" Microstrip
Z3	0.052" x 0.051" Microstrip	Z13, Z14	0.052" x 0.393" Microstrip	Z23	0.240" x 0.051" Microstrip
Z4	0.185" x 0.051" Microstrip	Z15, Z16	0.119" x 0.393" Microstrip	Z24	0.280" x 0.051" Microstrip
Z5*, Z6*	0.408" x 0.071" Microstrip	Z17, Z18	0.083" x 0.393" Microstrip	Z25	0.157" x 0.051" Microstrip
Z7, Z8	0.035" x 0.393" Microstrip				

\* Line length includes microstrip bends

## TYPICAL CHARACTERISTICS — 764-870 MHz BROADBAND REFERENCE CIRCUIT

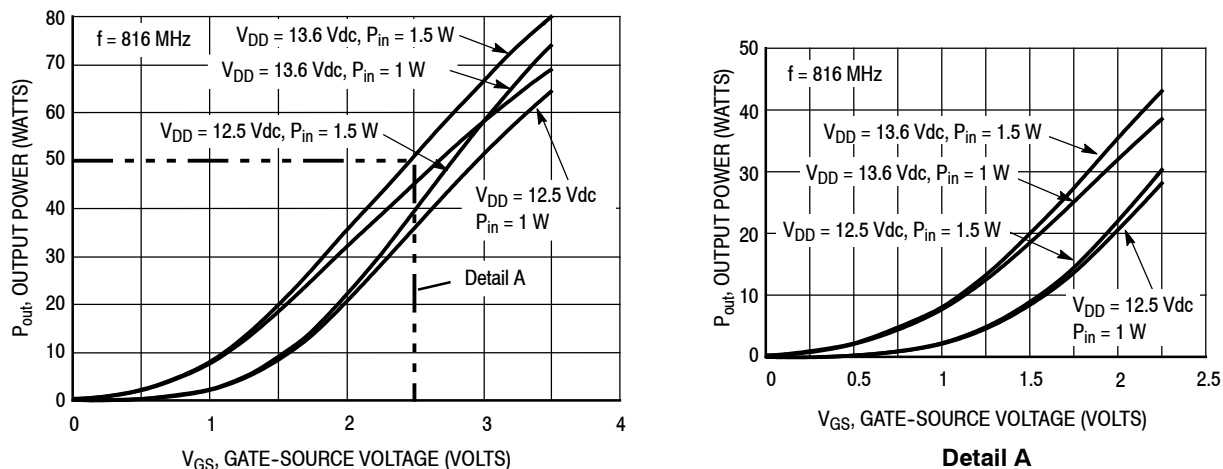


**Figure 12. Power Gain, Output Power and Drain Efficiency versus Frequency at a Constant Input Power — 12.5 Vdc**

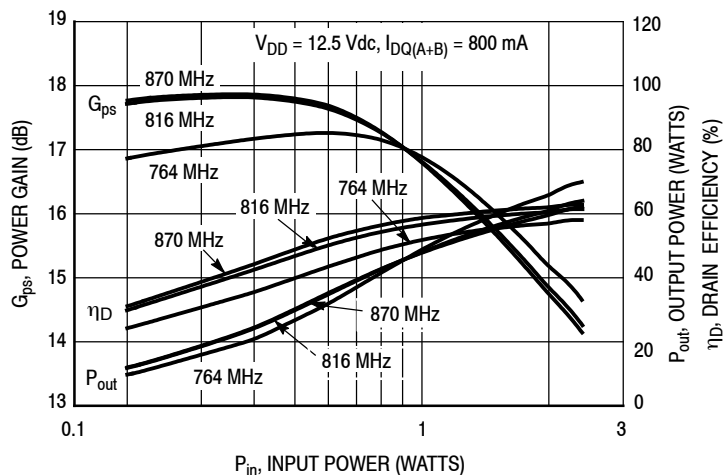


**Figure 13. Power Gain, Output Power and Drain Efficiency versus Frequency at a Constant Input Power — 13.6 Vdc**

## TYPICAL CHARACTERISTICS — 764-870 MHz BROADBAND REFERENCE CIRCUIT

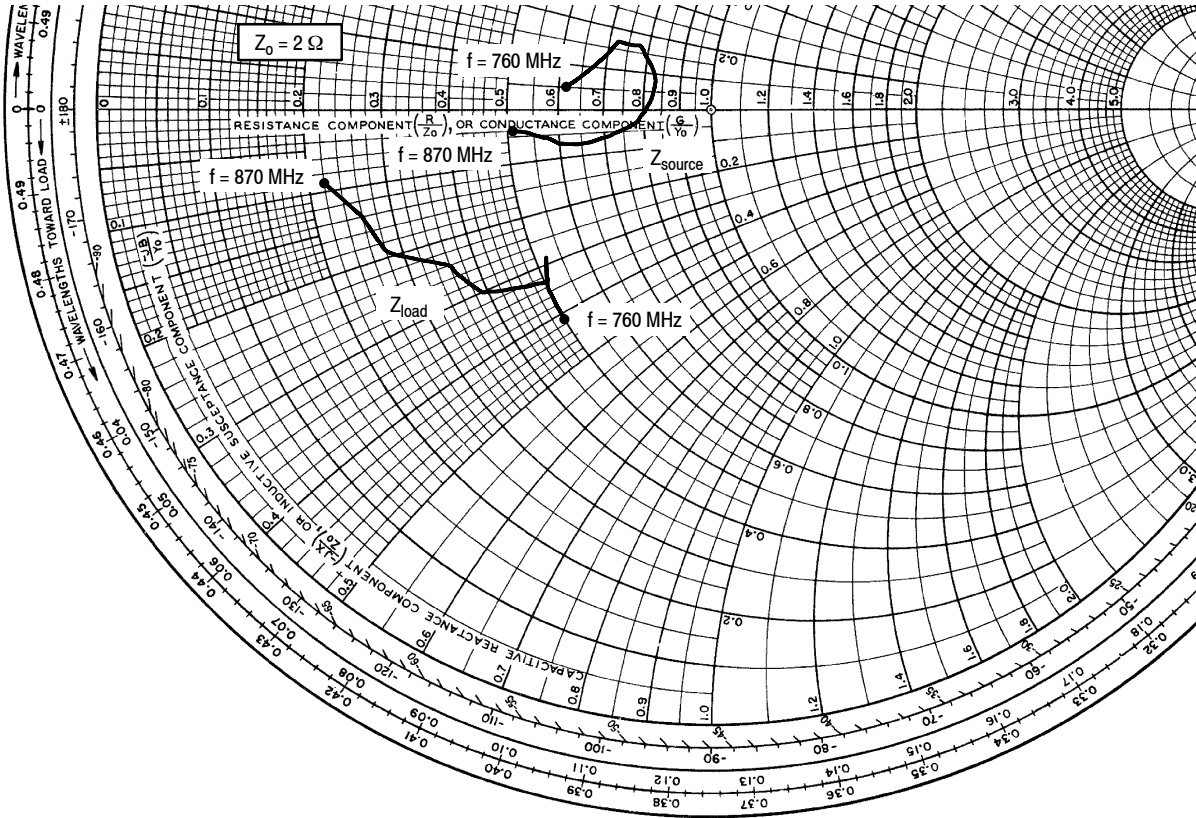


**Figure 14. Output Power versus Gate-Source Voltage**



**Figure 15. Power Gain, Output Power and Drain Efficiency versus Input Power and Frequency**

### 764-870 MHz BROADBAND REFERENCE CIRCUIT



$V_{DD} = 12.5 \text{ Vdc}$ ,  $I_{DQ(A+B)} = 800 \text{ mA}$ ,  $P_{out} = 55 \text{ W Avg.}$

f MHz	$Z_{source}$ $\Omega$	$Z_{load}$ $\Omega$
760	$1.24 + j0.09$	$1.00 - j0.81$
770	$1.30 + j0.15$	$1.00 - j0.75$
780	$1.35 + j0.21$	$1.00 - j0.72$
790	$1.43 + j0.34$	$1.01 - j0.61$
800	$1.54 + j0.34$	$1.03 - j0.58$
810	$1.66 + j0.18$	$0.99 - j0.65$
820	$1.63 + j0.06$	$0.90 - j0.63$
830	$1.55 - j0.07$	$0.78 - j0.60$
840	$1.42 - j0.12$	$0.71 - j0.48$
850	$1.21 - j0.13$	$0.56 - j0.37$
860	$1.15 - j0.12$	$0.52 - j0.28$
870	$1.01 - j0.10$	$0.43 - j0.17$

$Z_{source}$  = Test circuit impedance as measured from gate to ground.

$Z_{load}$  = Test circuit impedance as measured from drain to ground.

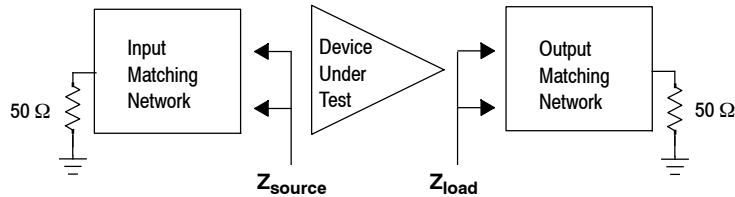
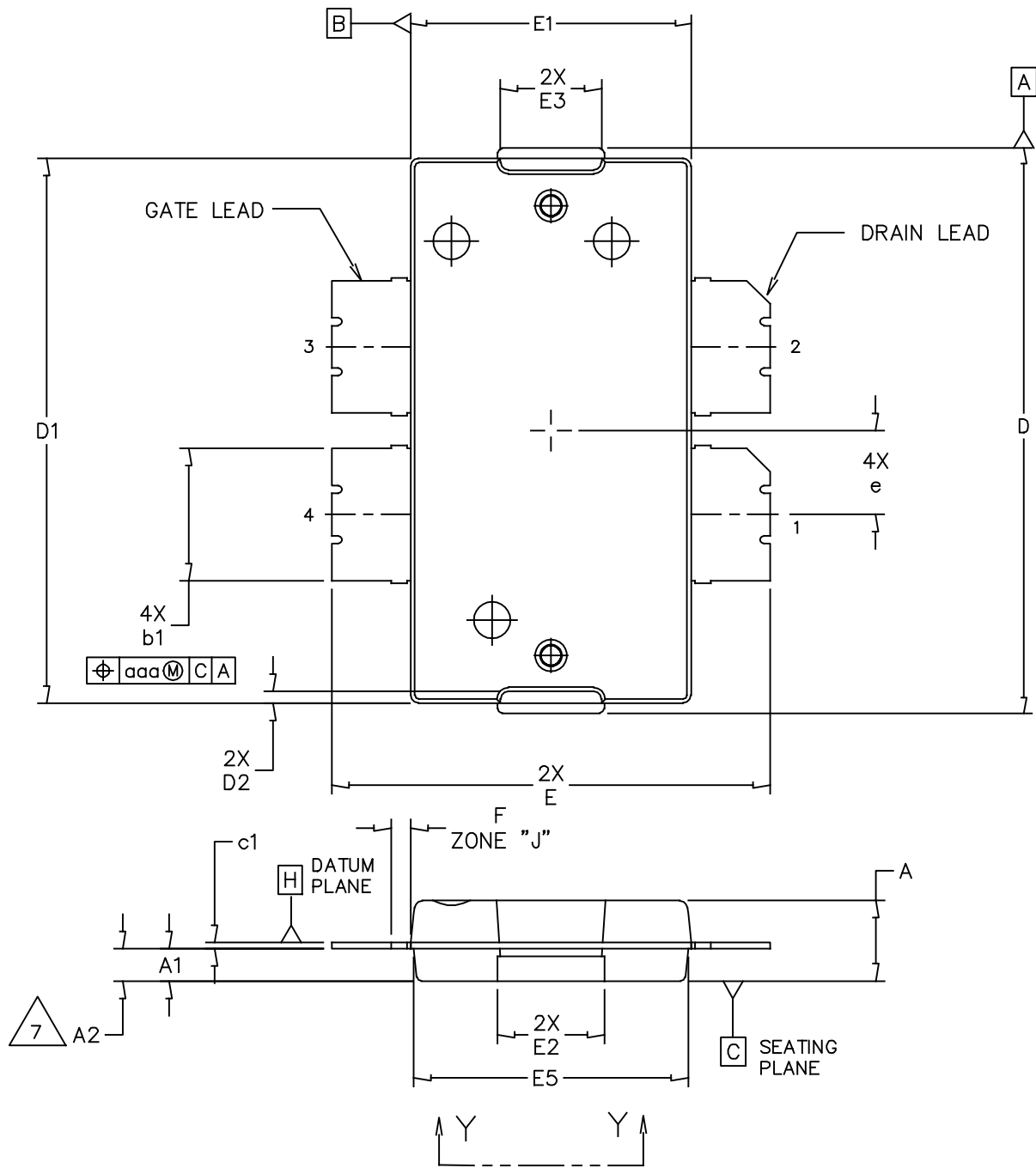
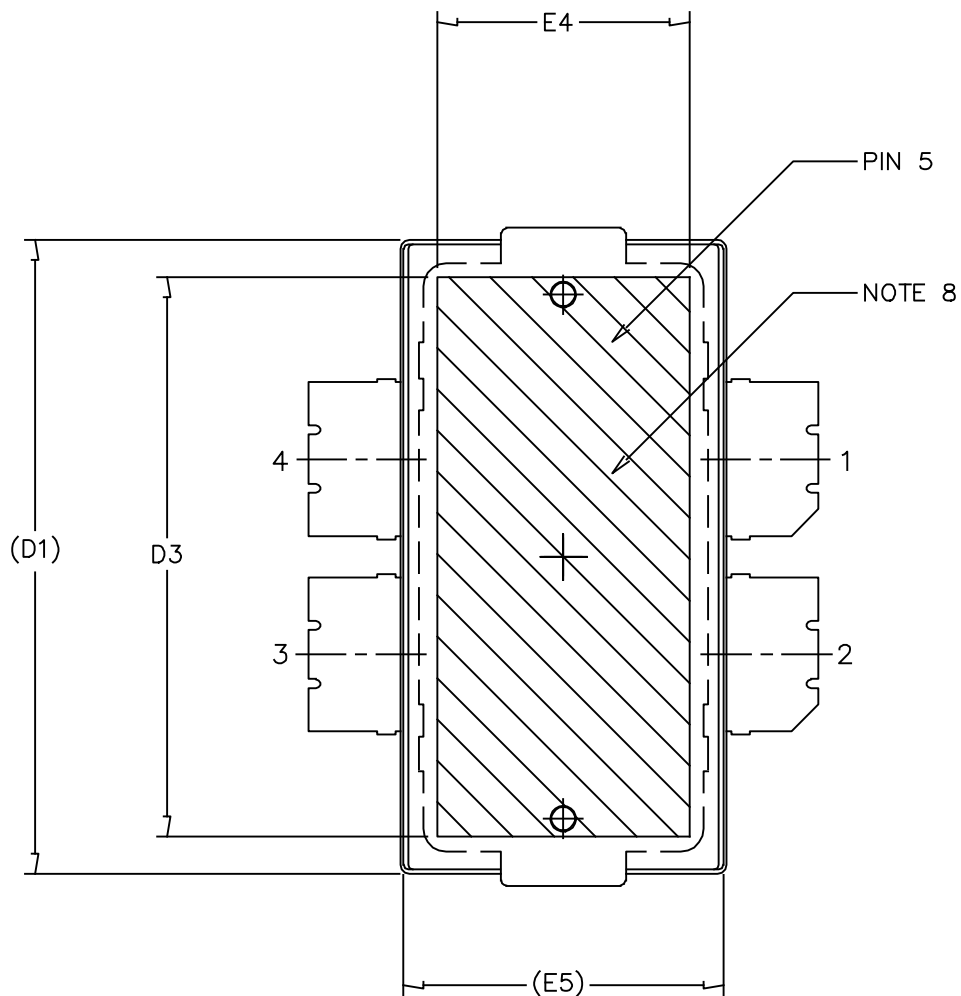


Figure 16. Broadband Series Equivalent Source and Load Impedance — 764-870 MHz

**PACKAGE DIMENSIONS**



© FREESCALE SEMICONDUCTOR, INC. ALL RIGHTS RESERVED.	MECHANICAL OUTLINE	PRINT VERSION NOT TO SCALE	
TITLE: TO-270 4 LEAD, WIDE BODY	DOCUMENT NO: 98ASA10577D	REV: D	
	CASE NUMBER: 1486-03	13 AUG 2007	
	STANDARD: NON-JEDEC		



© FREESCALE SEMICONDUCTOR, INC. ALL RIGHTS RESERVED.	MECHANICAL OUTLINE	PRINT VERSION NOT TO SCALE	
TITLE: TO-270 4 LEAD, WIDE BODY		DOCUMENT NO: 98ASA10577D	REV: D
		CASE NUMBER: 1486-03	13 AUG 2007
		STANDARD: NON-JEDEC	

NOTES:

1. CONTROLLING DIMENSION: INCH
2. INTERPRET DIMENSIONS AND TOLERANCES PER ASME Y14.5M-1994.
3. DATUM PLANE -H- IS LOCATED AT THE TOP OF LEAD AND IS COINCIDENT WITH THE LEAD WHERE THE LEAD EXITS THE PLASTIC BODY AT THE TOP OF THE PARTING LINE.
4. DIMENSIONS "D" AND "E1" DO NOT INCLUDE MOLD PROTRUSION. ALLOWABLE PROTRUSION IS .006 PER SIDE. DIMENSIONS "D" AND "E1" DO INCLUDE MOLD MISMATCH AND ARE DETERMINED AT DATUM PLANE -H-.
5. DIMENSIONS "b1" DOES NOT INCLUDE DAMBAR PROTRUSION. ALLOWABLE DAMBAR PROTRUSION SHALL BE .005 TOTAL IN EXCESS OF THE "b1" DIMENSION AT MAXIMUM MATERIAL CONDITION.
6. DATUMS -A- AND -B- TO BE DETERMINED AT DATUM PLANE -H-.
7. DIMENSION A2 APPLIES WITHIN ZONE "J" ONLY.
8. HATCHING REPRESENTS THE EXPOSED AREA OF THE HEAT SLUG.

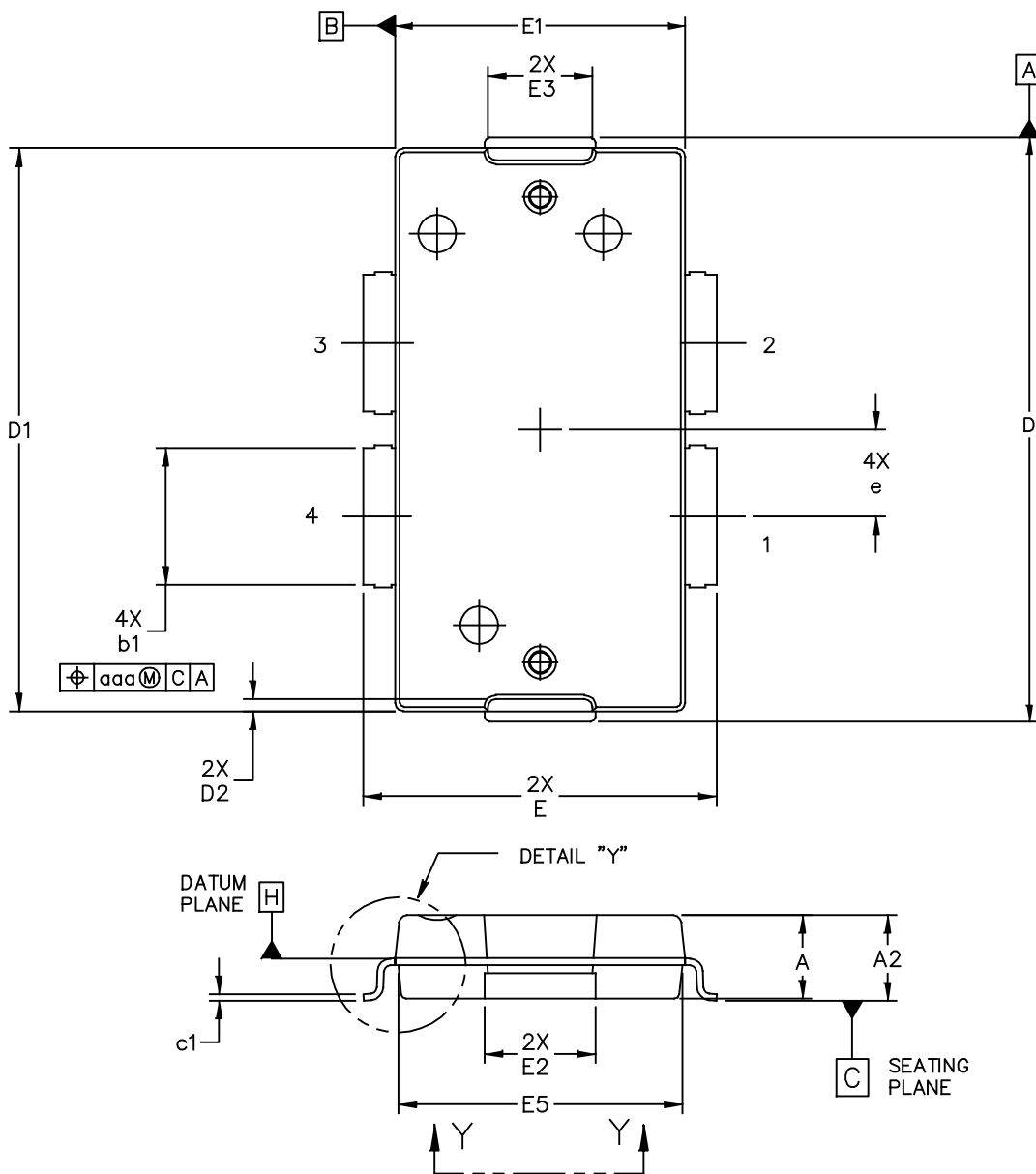
STYLE 1:

PIN 1 - DRAIN      PIN 2 - DRAIN  
 PIN 3 - GATE      PIN 4 - GATE  
 PIN 5 - SOURCE

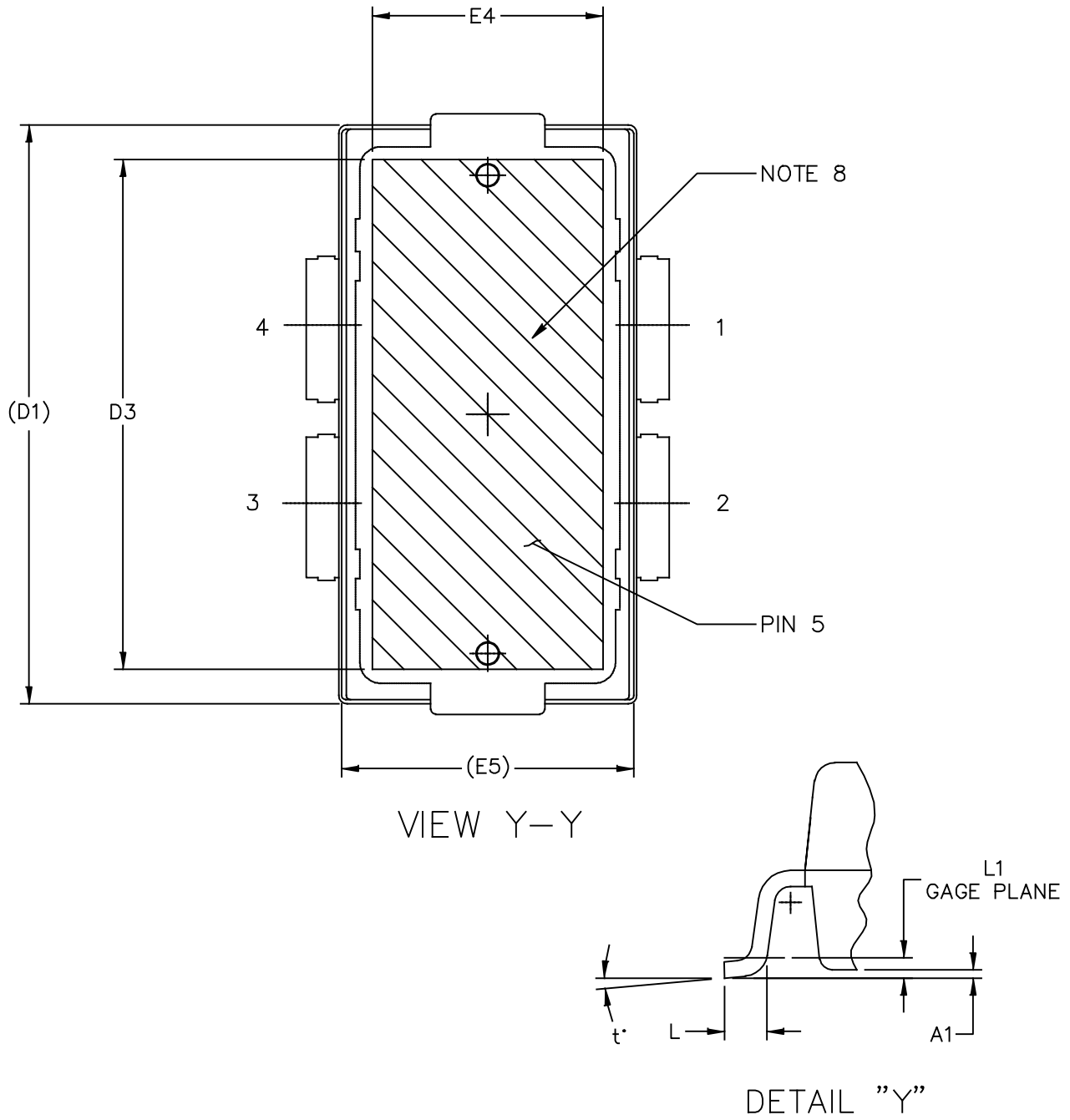
DIM	INCH		MILLIMETER		DIM	INCH		MILLIMETER	
	MIN	MAX	MIN	MAX		MIN	MAX	MIN	MAX
A	.100	.104	2.54	2.64	F	.025 BSC		0.64 BSC	
A1	.039	.043	0.99	1.09	b1	.164	.170	4.17	4.32
A2	.040	.042	1.02	1.07	c1	.007	.011	.18	.28
D	.712	.720	18.08	18.29	e	.106 BSC		2.69 BSC	
D1	.688	.692	17.48	17.58	aaa	.004		.10	
D2	.011	.019	0.28	0.48					
D3	.600	---	15.24	---					
E	.551	.559	14	14.2					
E1	.353	.357	8.97	9.07					
E2	.132	.140	3.35	3.56					
E3	.124	.132	3.15	3.35					
E4	.270	---	6.86	---					
E5	.346	.350	8.79	8.89					

© FREESCALE SEMICONDUCTOR, INC. ALL RIGHTS RESERVED.		MECHANICAL OUTLINE		PRINT VERSION NOT TO SCALE	
TITLE:  TO-270 4 LEAD WIDE BODY			DOCUMENT NO: 98ASA10577D		REV: D
			CASE NUMBER: 1486-03		13 AUG 2007
			STANDARD: NON-JEDEC		





© FREESCALE SEMICONDUCTOR, INC. ALL RIGHTS RESERVED.	MECHANICAL OUTLINE	PRINT VERSION NOT TO SCALE	
TITLE: TO-270 4 LEAD, WIDE BODY GULL WING	DOCUMENT NO: 98ASA10578D	REV: D	
	CASE NUMBER: 1487-05	03 AUG 2007	
	STANDARD: JEDEC TO-270 BB		



© FREESCALE SEMICONDUCTOR, INC. ALL RIGHTS RESERVED.	MECHANICAL OUTLINE	PRINT VERSION NOT TO SCALE	
TITLE: TO-270 4 LEAD, WIDE BODY GULL WING	DOCUMENT NO: 98ASA10578D	REV: D	
	CASE NUMBER: 1487-05	03 AUG 2007	
	STANDARD: JEDEC TO-270 BB		

NOTES:

1. CONTROLLING DIMENSION: INCH
2. INTERPRET DIMENSIONS AND TOLERANCES PER ASME Y14.5M-1994.
3. DATUM PLANE -H- IS LOCATED AT THE TOP OF LEAD AND IS COINCIDENT WITH THE LEAD WHERE THE LEAD EXITS THE PLASTIC BODY AT THE TOP OF THE PARTING LINE.
4. DIMENSIONS "D" AND "E1" DO NOT INCLUDE MOLD PROTRUSION. ALLOWABLE PROTRUSION IS .006 (0.15) PER SIDE. DIMENSIONS "D" AND "E1" DO INCLUDE MOLD MISMATCH AND ARE DETERMINED AT DATUM PLANE -H-.
5. DIMENSION "b1" DOES NOT INCLUDE DAMBAR PROTRUSION. ALLOWABLE DAMBAR PROTRUSION SHALL BE .005 (0.13) TOTAL IN EXCESS OF THE "b1" DIMENSION AT MAXIMUM MATERIAL CONDITION.
6. HATCHING REPRESENTS THE EXPOSED AREA OF THE HEAT SLUG.

STYLE 1:

- PIN 1 - DRAIN
- PIN 2 - DRAIN
- PIN 3 - GATE
- PIN 4 - GATE
- PIN 5 - SOURCE

DIM	INCH		MILLIMETER		DIM	INCH		MILLIMETER	
	MIN	MAX	MIN	MAX		MIN	MAX	MIN	MAX
A	.100	.104	2.54	2.64	L	.018	.024	0.46	0.61
A1	.001	.004	0.02	0.10	L1	.01 BSC		0.25 BSC	
A2	.101	.108	2.56	2.74	b1	.164	.170	4.17	4.32
D	.712	.720	18.08	18.29	c1	.007	.011	.18	.28
D1	.688	.692	17.48	17.58	e	.106 BSC		2.69 BSC	
D2	.011	.019	0.28	0.48	t	2'	8'	2'	8'
D3	.600	-----	15.24	-----	aaa	.004		0.1	
E	.429	.437	10.90	11.10					
E1	.353	.357	8.97	9.07					
E2	.132	.140	3.35	3.56					
E3	.124	.132	3.15	3.35					
E4	.270	-----	6.86	-----					
E5	.346	.350	8.79	8.89					
© FREESCALE SEMICONDUCTOR, INC. ALL RIGHTS RESERVED.			MECHANICAL OUTLINE			PRINT VERSION NOT TO SCALE			
TITLE: TO-270 4 LEAD, WIDE BODY GULL WING					DOCUMENT NO: 98ASA10578D			REV: D	
					CASE NUMBER: 1487-05			03 AUG 2007	
					STANDARD: JEDEC TO-270 BB				

## PRODUCT DOCUMENTATION, SOFTWARE AND TOOLS

Refer to the following documents, software and tools to aid your design process.

### Application Notes

- AN1955: Thermal Measurement Methodology of RF Power Amplifiers

### Engineering Bulletins

- EB212: Using Data Sheet Impedances for RF LDMOS Devices

### Software

- Electromigration MTTF Calculator
- RF High Power Model
- .s2p File

### Development Tools

- Printed Circuit Boards

For Software and Tools, do a Part Number search at <http://www.freescale.com>, and select the “Part Number” link. Go to the Software & Tools tab on the part’s Product Summary page to download the respective tool.

## REVISION HISTORY

The following table summarizes revisions to this document.

Revision	Date	Description
0	July 2013	• Initial Release of Data Sheet

### ***How to Reach Us:***

**Home Page:**  
[freescale.com](http://freescale.com)

**Web Support:**  
[freescale.com/support](http://freescale.com/support)

Information in this document is provided solely to enable system and software implementers to use Freescale products. There are no express or implied copyright licenses granted hereunder to design or fabricate any integrated circuits based on the information in this document.

Freescale reserves the right to make changes without further notice to any products herein. Freescale makes no warranty, representation, or guarantee regarding the suitability of its products for any particular purpose, nor does Freescale assume any liability arising out of the application or use of any product or circuit, and specifically disclaims any and all liability, including without limitation consequential or incidental damages. "Typical" parameters that may be provided in Freescale data sheets and/or specifications can and do vary in different applications, and actual performance may vary over time. All operating parameters, including "typicals," must be validated for each customer application by customer's technical experts. Freescale does not convey any license under its patent rights nor the rights of others. Freescale sells products pursuant to standard terms and conditions of sale, which can be found at the following address: [freescale.com/SalesTermsandConditions](http://freescale.com/SalesTermsandConditions).

Freescale and the Freescale logo are trademarks of Freescale Semiconductor, Inc., Reg. U.S. Pat. & Tm. Off. Airfast is a trademark of Freescale Semiconductor, Inc. All other product or service names are the property of their respective owners.

© 2013 Freescale Semiconductor, Inc.



## Стандарт Электрон Связь

Мы молодая и активно развивающаяся компания в области поставок электронных компонентов. Мы поставляем электронные компоненты отечественного и импортного производства напрямую от производителей и с крупнейших складов мира.

Благодаря сотрудничеству с мировыми поставщиками мы осуществляем комплексные и плановые поставки широчайшего спектра электронных компонентов.

Собственная эффективная логистика и склад в обеспечивает надежную поставку продукции в точно указанные сроки по всей России.

Мы осуществляем техническую поддержку нашим клиентам и предпродажную проверку качества продукции. На все поставляемые продукты мы предоставляем гарантию .

Осуществляем поставки продукции под контролем ВП МО РФ на предприятия военно-промышленного комплекса России , а также работаем в рамках 275 ФЗ с открытием отдельных счетов в уполномоченном банке. Система менеджмента качества компании соответствует требованиям ГОСТ ISO 9001.

Минимальные сроки поставки, гибкие цены, неограниченный ассортимент и индивидуальный подход к клиентам являются основой для выстраивания долгосрочного и эффективного сотрудничества с предприятиями радиоэлектронной промышленности, предприятиями ВПК и научно-исследовательскими институтами России.

С нами вы становитесь еще успешнее!

### Наши контакты:

**Телефон:** +7 812 627 14 35

**Электронная почта:** [sales@st-electron.ru](mailto:sales@st-electron.ru)

**Адрес:** 198099, Санкт-Петербург,  
Промышленная ул, дом № 19, литера Н,  
помещение 100-Н Офис 331