

RLDRAM 3

MT44K32M18 – 2 Meg x 18 x 16 Banks

MT44K16M36 – 1 Meg x 36 x 16 Banks

Features

- 1066 MHz DDR operation (2133 Mb/s/ball data rate)
- 76.8 Gb/s peak bandwidth (x36 at 1066 MHz clock frequency)
- Organization
 - 32 Meg x 18, and 16 Meg x 36 common I/O (CIO)
 - 16 banks
- 1.2V center-terminated push/pull I/O
- 2.5V_{V_{EXT}}, 1.35V_{V_{DD}}, 1.2V_{V_{DDQ}} I/O
- Reduced cycle time (^tRC (MIN) = 7.5 - 12ns)
- SDR addressing
- Programmable READ/WRITE latency (RL/WL) and burst length
- Data mask for WRITE commands
- Differential input clocks (CK, CK#)
- Free-running differential input data clocks (DKx, DKx#) and output data clocks (QKx, QKx#)
- On-die DLL generates CK edge-aligned data and differential output data clock signals
- 64ms refresh (128K refresh per 64ms)
- 168-ball BGA package
- 40Ω or 60Ω matched impedance outputs
- Integrated on-die termination (ODT)
- Single or multibank writes
- Extended operating range (200–1066 MHz)
- READ training register
- Multiplexed and non-multiplexed addressing capabilities
- Mirror function
- Output driver and ODT calibration
- JTAG interface (IEEE 1149.1-2001)

Options¹

- Clock cycle and ^tRC timing
 - 0.93ns and ^tRC (MIN) = 7.5ns (RL3-2133) -093F
 - 0.93ns and ^tRC (MIN) = 8ns (RL3-2133) -093E
 - 1.07ns and ^tRC (MIN) = 8ns (RL3-1866) -107E
 - 1.25ns and ^tRC (MIN) = 8ns (RL3-1600) -125F
 - 1.25ns and ^tRC (MIN) = 10ns (RL3-1600) -125E
 - 1.25ns and ^tRC (MIN) = 12ns (RL3-1600) -125
- Configuration
 - 32 Meg x 18 32M18
 - 16 Meg x 36 16M36
- Operating temperature
 - Commercial (T_C = 0° to +95°C) None
 - Industrial (T_C = -40°C to +95°C) IT
- Package
 - 168-ball BGA (Pb-free) RB
- Revision :A / :B

Note: 1. Not all options listed can be combined to define an offered product. Use the part catalog search on www.micron.com for available offerings.

Figure 1: 576Mb RLD RAM® 3 Part Numbers



BGA Part Marking Decoder

Due to space limitations, BGA-packaged components have an abbreviated part marking that is different from the part number. Micron’s BGA Part Marking Decoder is available on Micron’s Web site at www.micron.com.

Contents

General Description	9
General Notes	9
State Diagram	10
Functional Block Diagrams	11
Ball Assignments and Descriptions	13
Package Dimensions	17
Electrical Characteristics – I _{DD} Specifications	18
Electrical Specifications – Absolute Ratings and I/O Capacitance	25
Absolute Maximum Ratings	25
Input/Output Capacitance	25
AC and DC Operating Conditions	26
AC Overshoot/Undershoot Specifications	28
Slew Rate Definitions for Single-Ended Input Signals	31
Slew Rate Definitions for Differential Input Signals	33
ODT Characteristics	34
ODT Resistors	34
ODT Sensitivity	36
Output Driver Impedance	36
Output Driver Sensitivity	37
Output Characteristics and Operating Conditions	39
Reference Output Load	42
Slew Rate Definitions for Single-Ended Output Signals	43
Slew Rate Definitions for Differential Output Signals	44
Speed Bin Tables	45
AC Electrical Characteristics	47
Temperature and Thermal Impedance Characteristics	53
Command and Address Setup, Hold, and Derating	55
Data Setup, Hold, and Derating	62
Commands	69
MODE REGISTER SET (MRS) Command	70
Mode Register 0 (MR0)	71
^t RC	72
Data Latency	72
DLL Enable/Disable	72
Address Multiplexing	72
Mode Register 1 (MR1)	74
Output Drive Impedance	74
DQ On-Die Termination (ODT)	74
DLL Reset	74
ZQ Calibration	75
ZQ Calibration Long	76
ZQ Calibration Short	76
AUTO REFRESH Protocol	77
Burst Length (BL)	77
Mode Register 2 (MR2)	79
READ Training Register (RTR)	79
WRITE Protocol	81
WRITE Command	81
Multibank WRITE	82
READ Command	82



AUTO REFRESH Command	84
INITIALIZATION Operation	86
WRITE Operation	88
READ Operation	92
AUTO REFRESH Operation	95
RESET Operation	98
Clock Stop	99
Mirror Function	100
Multiplexed Address Mode	101
Data Latency in Multiplexed Address Mode	106
REFRESH Command in Multiplexed Address Mode	106
IEEE 1149.1 Serial Boundary Scan (JTAG)	110
Disabling the JTAG Feature	110
Test Access Port (TAP)	110
TAP Controller	111
Performing a TAP RESET	113
TAP Registers	113
TAP Instruction Set	114

List of Figures

Figure 1: 576Mb RLD RAM [®] 3 Part Numbers	2
Figure 2: Simplified State Diagram	10
Figure 3: 32 Meg x 18 Functional Block Diagram	11
Figure 4: 16 Meg x 36 Functional Block Diagram	12
Figure 5: 168-Ball BGA	17
Figure 6: Single-Ended Input Signal	27
Figure 7: Overshoot	28
Figure 8: Undershoot	28
Figure 9: V_{IX} for Differential Signals	29
Figure 10: Single-Ended Requirements for Differential Signals	30
Figure 11: Definition of Differential AC Swing and t_{DVAC}	30
Figure 12: Nominal Slew Rate Definition for Single-Ended Input Signals	32
Figure 13: Nominal Differential Input Slew Rate Definition for CK, CK#, DKx, and DKx#	33
Figure 14: ODT Levels and I-V Characteristics	34
Figure 15: Output Driver	37
Figure 16: DQ Output Signal	41
Figure 17: Differential Output Signal	42
Figure 18: Reference Output Load for AC Timing and Output Slew Rate	42
Figure 19: Nominal Slew Rate Definition for Single-Ended Output Signals	43
Figure 20: Nominal Differential Output Slew Rate Definition for QKx, QKx#	44
Figure 21: Example Temperature Test Point Location	54
Figure 22: Nominal Slew Rate and t_{VAC} for t_{IS} (Command and Address - Clock)	58
Figure 23: Nominal Slew Rate for t_{IH} (Command and Address - Clock)	59
Figure 24: Tangent Line for t_{IS} (Command and Address - Clock)	60
Figure 25: Tangent Line for t_{IH} (Command and Address - Clock)	61
Figure 26: Nominal Slew Rate and t_{VAC} for t_{DS} (DQ - Strobe)	65
Figure 27: Nominal Slew Rate for t_{DH} (DQ - Strobe)	66
Figure 28: Tangent Line for t_{DS} (DQ - Strobe)	67
Figure 29: Tangent Line for t_{DH} (DQ - Strobe)	68
Figure 30: MRS Command Protocol	70
Figure 31: MR0 Definition for Non-Multiplexed Address Mode	71
Figure 32: MR1 Definition for Non-Multiplexed Address Mode	74
Figure 33: ZQ Calibration Timing (ZQCL and ZQCS)	76
Figure 34: Read Burst Lengths	78
Figure 35: MR2 Definition for Non-Multiplexed Address Mode	79
Figure 36: READ Training Function - Back-to-Back Readout	80
Figure 37: WRITE Command	81
Figure 38: READ Command	83
Figure 39: Bank Address-Controlled AUTO REFRESH Command	84
Figure 40: Multibank AUTO REFRESH Command	85
Figure 41: Power-Up/Initialization Sequence	87
Figure 42: WRITE Burst	88
Figure 43: Consecutive WRITE Bursts	89
Figure 44: WRITE-to-READ	89
Figure 45: WRITE - DM Operation	90
Figure 46: Consecutive Quad Bank WRITE Bursts	90
Figure 47: Interleaved READ and Quad Bank WRITE Bursts	91
Figure 48: Basic READ Burst	92
Figure 49: Consecutive READ Bursts (BL = 2)	93
Figure 50: Consecutive READ Bursts (BL = 4)	93

Figure 51: READ-to-WRITE (BL = 2)	94
Figure 52: Read Data Valid Window	94
Figure 53: Bank Address-Controlled AUTO REFRESH Cycle	95
Figure 54: Multibank AUTO REFRESH Cycle	95
Figure 55: READ Burst with ODT	96
Figure 56: READ-NOP-READ with ODT	97
Figure 57: RESET Sequence	98
Figure 58: Command Description in Multiplexed Address Mode	101
Figure 59: Power-Up/Initialization Sequence in Multiplexed Address Mode	102
Figure 60: MR0 Definition for Multiplexed Address Mode	103
Figure 61: MR1 Definition for Multiplexed Address Mode	104
Figure 62: MR2 Definition for Multiplexed Address Mode	105
Figure 63: Bank Address-Controlled AUTO REFRESH Operation with Multiplexed Addressing	106
Figure 64: Multibank AUTO REFRESH Operation with Multiplexed Addressing	106
Figure 65: Consecutive WRITE Bursts with Multiplexed Addressing	107
Figure 66: WRITE-to-READ with Multiplexed Addressing	108
Figure 67: Consecutive READ Bursts with Multiplexed Addressing	108
Figure 68: READ-to-WRITE with Multiplexed Addressing	109
Figure 69: TAP Controller State Diagram	112
Figure 70: TAP Controller Functional Block Diagram	112
Figure 71: JTAG Operation - Loading Instruction Code and Shifting Out Data	115
Figure 72: TAP Timing	116

List of Tables

Table 1: 32 Meg x 18 Ball Assignments – 168-Ball BGA (Top View)	13
Table 2: 16 Meg x 36 Ball Assignments – 168-Ball BGA (Top View)	14
Table 3: Ball Descriptions	15
Table 4: I _{DD} Operating Conditions and Maximum Limits (Die Rev :A)	18
Table 5: I _{DD} Operating Conditions and Maximum Limits (Die Rev :B)	22
Table 6: Absolute Maximum Ratings	25
Table 7: Input/Output Capacitance	25
Table 8: DC Electrical Characteristics and Operating Conditions	26
Table 9: Input AC Logic Levels	26
Table 10: Control and Address Balls	28
Table 11: Clock, Data, Strobe, and Mask Balls	28
Table 12: Differential Input Operating Conditions (CK, CK# and DKx, DKx#)	29
Table 13: Allowed Time Before Ringback (^t DVAC) for CK, CK#, DKx, and DKx#	31
Table 14: Single-Ended Input Slew Rate Definition	31
Table 15: Differential Input Slew Rate Definition	33
Table 16: ODT DC Electrical Characteristics	34
Table 17: R _{TT} Effective Impedances	35
Table 18: ODT Sensitivity Definition	36
Table 19: ODT Temperature and Voltage Sensitivity	36
Table 20: Driver Pull-Up and Pull-Down Impedance Calculations	37
Table 21: Output Driver Sensitivity Definition	38
Table 22: Output Driver Voltage and Temperature Sensitivity	38
Table 23: Single-Ended Output Driver Characteristics	39
Table 24: Differential Output Driver Characteristics	40
Table 25: Single-Ended Output Slew Rate Definition	43
Table 26: Differential Output Slew Rate Definition	44
Table 27: RL3 2133/1866 Speed Bins	45
Table 28: RL3 1600 Speed Bins	46
Table 29: AC Electrical Characteristics	47
Table 30: Temperature Limits	53
Table 31: Thermal Impedance	53
Table 32: Command and Address Setup and Hold Values Referenced at 1 V/ns – AC/DC-Based	55
Table 33: Derating Values for ^t IS/ ^t IH – AC150/DC100-Based	56
Table 34: Derating Values for ^t IS/ ^t IH – AC120/DC100-Based	57
Table 35: Minimum Required Time ^t VAC Above V _{IH(AC)} (or Below V _{IL(AC)}) for Valid Transition	57
Table 36: Data Setup and Hold Values at 1 V/ns (DKx, DKx# at 2V/ns) – AC/DC-Based	62
Table 37: Derating Values for ^t DS/ ^t DH – AC150/DC100-Based	63
Table 38: Derating Values for ^t DS/ ^t DH – AC120/DC100-Based	64
Table 39: Minimum Required Time ^t VAC Above V _{IH(AC)} (or Below V _{IL(AC)}) for Valid Transition	64
Table 40: Command Descriptions	69
Table 41: Command Table	69
Table 42: ^t RC_MRS Values	72
Table 43: Address Widths of Different Burst Lengths	77
Table 44: 32 Meg x 18 Ball Assignments with MF Ball Tied HIGH	100
Table 45: Address Mapping in Multiplexed Address Mode	105
Table 46: TAP Input AC Logic Levels	116
Table 47: TAP AC Electrical Characteristics	116
Table 48: TAP DC Electrical Characteristics and Operating Conditions	117
Table 49: Identification Register Definitions	117
Table 50: Scan Register Sizes	118



Table 51: Instruction Codes	118
Table 52: Boundary Scan (Exit), Die Rev. A	118
Table 53: Boundary Scan (Exit), Die Rev. B	120

General Description

The Micron® RLD RAM® 3 is a high-speed memory device designed for high-bandwidth data storage—telecommunications, networking, cache applications, and so forth. The chip's 16-bank architecture is optimized for sustainable high-speed operation.

The DDR I/O interface transfers two data bits per clock cycle at the I/O balls. Output data is referenced to the READ strobes.

Commands, addresses, and control signals are also registered at every positive edge of the differential input clock, while input data is registered at both positive and negative edges of the input data strobes.

Read and write accesses to the RL3 device are burst-oriented. The burst length (BL) is programmable to 2, 4, or 8 by a setting in the mode register.

The device is supplied with 1.35V for the core and 1.2V for the output drivers. The 2.5V supply is used for an internal supply.

Bank-scheduled refresh is supported with the row address generated internally.

The 168-ball BGA package is used to enable ultra-high-speed data transfer rates.

General Notes

- The functionality and the timing specifications discussed in this data sheet are for the DLL enable mode of operation.
- Any functionality not specifically stated is considered undefined, illegal, and not supported, and can result in unknown operation.
- Nominal conditions are assumed for specifications not defined within the figures shown in this data sheet.
- Throughout this data sheet, the terms "RLDRAM," "DRAM," and "RLDRAM 3" are all used interchangeably and refer to the RLD RAM 3 SDRAM device.
- References to DQ, DK, QK, DM, and QVLD are to be interpreted as each group collectively, unless specifically stated otherwise. This includes true and complement signals of differential signals.
- Non-multiplexed operation is assumed if not specified as multiplexed.
- A x36 device supplies four QK/QK# sets, one per nine DQ. Using only two QK/QK# sets is allowed, but QK0/QK0# and QK1/QK1# must be used. QK0/QK0# control DQ[8:0] and DQ[26:18], and QK1/QK1# control DQ[17:9] and DQ[35:27]. The QK to DQ timing parameter to be used is ^tQKQ02, ^tQKQ13. The unused QK/QK# pins should be left floating.

State Diagram

Figure 2: Simplified State Diagram



Functional Block Diagrams

Figure 3: 32 Meg x 18 Functional Block Diagram

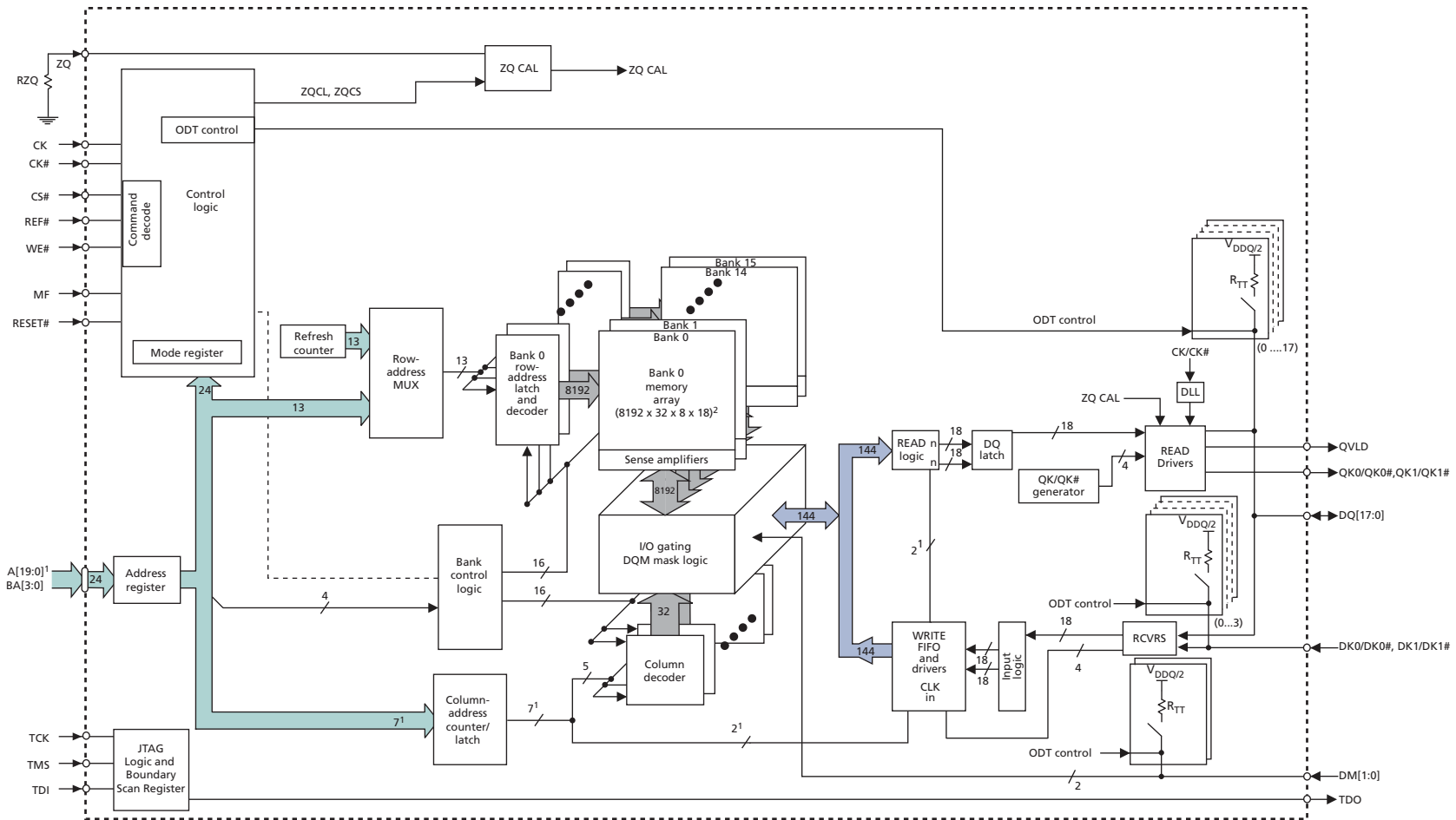

- Notes:
1. Example for BL = 2; column address will be reduced with an increase in burst length.
 2. $8 = (\text{length of burst}) \times 2^{\wedge} (\text{number of column addresses to WRITE FIFO and READ logic})$.

Functional Block Diagrams

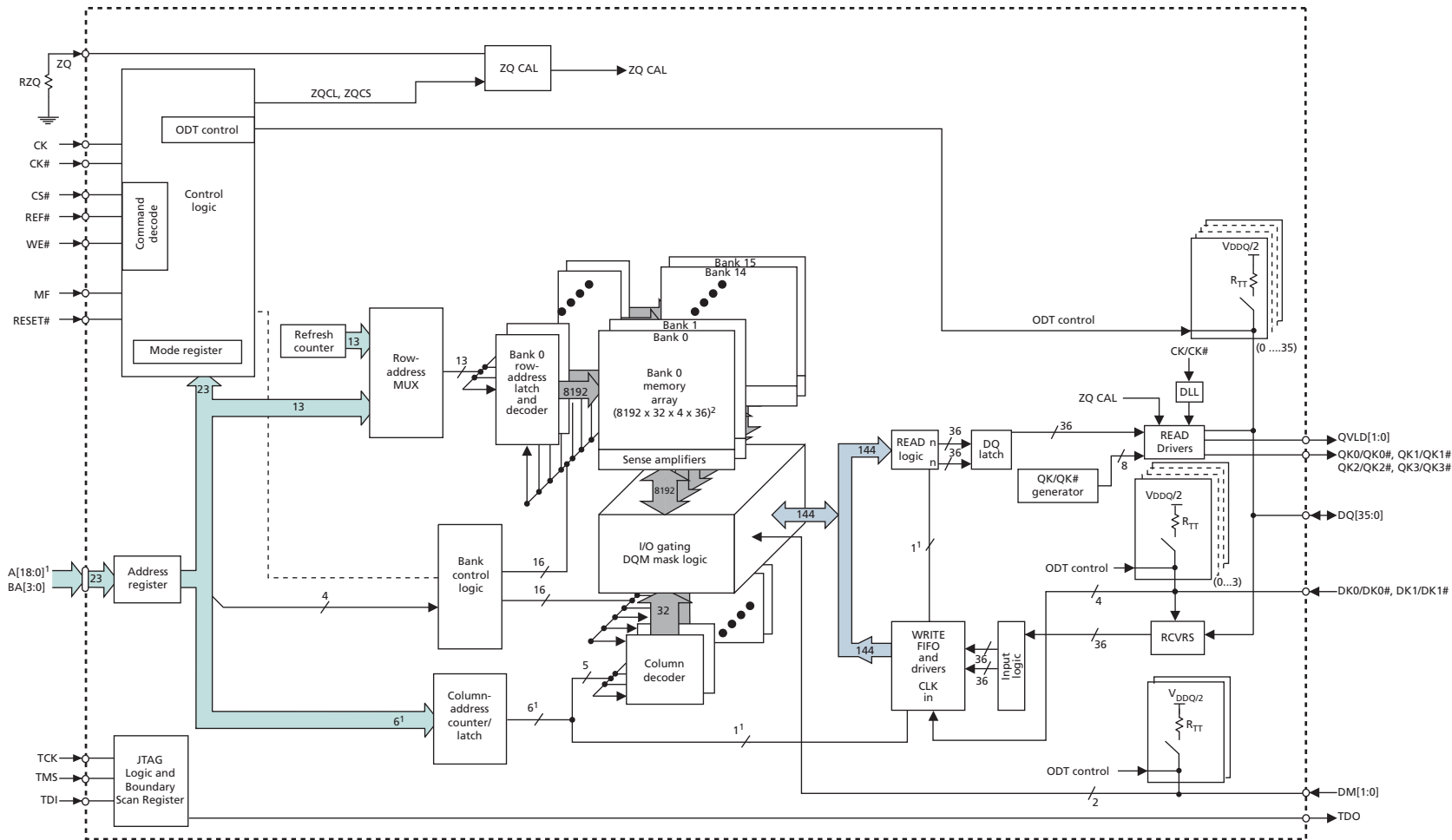
Figure 4: 16 Meg x 36 Functional Block Diagram

- Notes:
1. Example for BL = 2; column address will be reduced with an increase in burst length.
 2. $4 = (\text{length of burst}) \times 2^{\wedge} (\text{number of column addresses to WRITE FIFO and READ logic})$.

Ball Assignments and Descriptions

Table 1: 32 Meg x 18 Ball Assignments – 168-Ball BGA (Top View)

	1	2	3	4	5	6	7	8	9	10	11	12	13
A		V _{SS}	V _{DD}	NF	V _{DDQ}	NF	V _{REF}	DQ7	V _{DDQ}	DQ8	V _{DD}	V _{SS}	RESET#
B	V _{EXT}	V _{SS}	NF	V _{SSQ}	NF	V _{DDQ}	DM0	V _{DDQ}	DQ5	V _{SSQ}	DQ6	V _{SS}	V _{EXT}
C	V _{DD}	NF	V _{DDQ}	NF	V _{SSQ}	NF	DK0#	DQ2	V _{SSQ}	DQ3	V _{DDQ}	DQ4	V _{DD}
D	A11	V _{SSQ}	NF	V _{DDQ}	NF	V _{SSQ}	DK0	V _{SSQ}	QK0	V _{DDQ}	DQ0	V _{SSQ}	A13
E	V _{SS}	A0	V _{SSQ}	NF	V _{DDQ}	NF	MF	QK0#	V _{DDQ}	DQ1	V _{SSQ}	CS#	V _{SS}
F	A7	NF _(CS1/A20) ¹	V _{DD}	A2	A1	WE#	ZQ	REF#	A3	A4	V _{DD}	A5	A9
G	V _{SS}	A15	A6	V _{SS}	BA1	V _{SS}	CK#	V _{SS}	BA0	V _{SS}	A8	A18	V _{SS (RFU)} ²
H	A19	V _{DD}	A14	A16	V _{DD}	BA3	CK	BA2	V _{DD}	A17	A12	V _{DD}	A10
J	V _{DDQ}	NF	V _{SSQ}	NF	V _{DDQ}	NF	V _{SS}	QK1#	V _{DDQ}	DQ9	V _{SSQ}	QVLD	V _{DDQ}
K	NF	V _{SSQ}	NF	V _{DDQ}	NF	V _{SSQ}	DK1	V _{SSQ}	QK1	V _{DDQ}	DQ10	V _{SSQ}	DQ11
L	V _{DD}	NF	V _{DDQ}	NF	V _{SSQ}	NF	DK1#	DQ12	V _{SSQ}	DQ13	V _{DDQ}	DQ14	V _{DD}
M	V _{EXT}	V _{SS}	NF	V _{SSQ}	NF	V _{DDQ}	DM1	V _{DDQ}	DQ15	V _{SSQ}	DQ16	V _{SS}	V _{EXT}
N	V _{SS}	TCK	V _{DD}	TDO	V _{DDQ}	NF	V _{REF}	DQ17	V _{DDQ}	TDI	V _{DD}	TMS	V _{SS}

- Notes:
1. F2 is an NF ball for both the X18 & X36 576Mb devices, but is also the Location of CS1 to support the 1Gb x18 DDP device. This same ball has been designated as the location of A20 for the future 1Gb monolithic device. F2 is Internally connected so it can mirror the A5 address signal when MF is asserted HIGH and has parasitic characteristics of an address pin.
 2. G13 is a VSS ball for both X18 & X36 576Mb devices, but has been reserved for future use (RFU) on the 1Gb monolithic devices and will have parasitic characteristics of an address.
 3. NF balls for the x18 configuration are internally connected and have parasitic characteristics of an I/O. Balls may be connected to V_{SSQ}.
 4. MF is assumed to be tied LOW for this ball assignment.



Table 2: 16 Meg x 36 Ball Assignments – 168-Ball BGA (Top View)

	1	2	3	4	5	6	7	8	9	10	11	12	13
A		V _{SS}	V _{DD}	DQ26	V _{DDQ}	DQ25	V _{REF}	DQ7	V _{DDQ}	DQ8	V _{DD}	V _{SS}	RESET#
B	V _{EXT}	V _{SS}	DQ24	V _{SSQ}	DQ23	V _{DDQ}	DM0	V _{DDQ}	DQ5	V _{SSQ}	DQ6	V _{SS}	V _{EXT}
C	V _{DD}	DQ22	V _{DDQ}	DQ21	V _{SSQ}	DQ20	DK0#	DQ2	V _{SSQ}	DQ3	V _{DDQ}	DQ4	V _{DD}
D	A11	V _{SSQ}	DQ18	V _{DDQ}	QK2	V _{SSQ}	DK0	V _{SSQ}	QK0	V _{DDQ}	DQ0	V _{SSQ}	A13
E	V _{SS}	A0	V _{SSQ}	DQ19	V _{DDQ}	QK2#	MF	QK0#	V _{DDQ}	DQ1	V _{SSQ}	CS#	V _{SS}
F	A7	NF _(CS1/A20) ¹	V _{DD}	A2	A1	WE#	ZQ	REF#	A3	A4	V _{DD}	A5	A9
G	V _{SS}	A15	A6	V _{SS}	BA1	V _{SS}	CK#	V _{SS}	BA0	V _{SS}	A8	A18	V _{SS} (RFU) ²
H	NF _(A19) ³	V _{DD}	A14	A16	V _{DD}	BA3	CK	BA2	V _{DD}	A17	A12	V _{DD}	A10
J	V _{DDQ}	QVLD1	V _{SSQ}	DQ27	V _{DDQ}	QK3#	V _{SS}	QK1#	V _{DDQ}	DQ9	V _{SSQ}	QVLD0	V _{DDQ}
K	DQ29	V _{SSQ}	DQ28	V _{DDQ}	QK3	V _{SSQ}	DK1	V _{SSQ}	QK1	V _{DDQ}	DQ10	V _{SSQ}	DQ11
L	V _{DD}	DQ32	V _{DDQ}	DQ31	V _{SSQ}	DQ30	DK1#	DQ12	V _{SSQ}	DQ13	V _{DDQ}	DQ14	V _{DD}
M	V _{EXT}	V _{SS}	DQ34	V _{SSQ}	DQ33	V _{DDQ}	DM1	V _{DDQ}	DQ15	V _{SSQ}	DQ16	V _{SS}	V _{EXT}
N	V _{SS}	TCK	V _{DD}	TDO	V _{DDQ}	DQ35	V _{REF}	DQ17	V _{DDQ}	TDI	V _{DD}	TMS	V _{SS}

- Notes:
1. F2 is an NF ball for both the X18 & X36 576Mb devices, but is also the Location of CS1 to support the 1Gb x18 DDP device. This same ball has been designated as the location of A20 for the future 1Gb monolithic device. F2 is Internally connected so it can mirror the A5 address signal when MF is asserted HIGH and has parasitic characteristics of an address pin.
 2. G13 is a VSS ball for both X18 & X36 576Mb devices, but has been reserved for future use (RFU) on the 1Gb monolithic devices and will have parasitic characteristics of an address.
 3. NF ball for x36 configuration is internally connected and has parasitic characteristics of an address (A19 for x18 configuration). Ball may be connected to V_{SSQ}.
 4. MF is assumed to be tied LOW for this ball assignment.

Table 3: Ball Descriptions

Symbol	Type	Description
A[19:0]	Input	Address inputs: A[19:0] define the row and column addresses for READ and WRITE operations. During a MODE REGISTER SET, the address inputs define the register settings along with BA[3:0]. They are sampled at the rising edge of CK.
BA[3:0]	Input	Bank address inputs: Select the internal bank to which a command is being applied.
CK/CK#	Input	Input clock: CK and CK# are differential input clocks. Addresses and commands are latched on the rising edge of CK.
CS#	Input	Chip select: CS# enables the command decoder when LOW and disables it when HIGH. When the command decoder is disabled, new commands are ignored, but internal operations continue.
DQ[35:0]	I/O	Data input: The DQ signals form the 36-bit data bus. During READ commands, the data is referenced to both edges of QK. During WRITE commands, the data is sampled at both edges of DK.
DKx, DKx#	Input	Input data clock: DKx and DKx# are differential input data clocks. All input data is referenced to both edges of DKx. For the x36 device, DQ[8:0] and DQ[26:18] are referenced to DK0 and DK0#, and DQ[17:9] and DQ[35:27] are referenced to DK1 and DK1#. For the x18 device, DQ[8:0] are referenced to DK0 and DK0#, and DQ[17:9] are referenced to DK1 and DK1#. DKx and DKx# are free-running signals and must always be supplied to the device.
DM[1:0]	Input	Input data mask: DM is the input mask signal for WRITE data. Input data is masked when DM is sampled HIGH. DM0 is used to mask the lower byte for the x18 device and DQ[8:0] and DQ[26:18] for the x36 device. DM1 is used to mask the upper byte for the x18 device and DQ[17:9] and DQ[35:27] for the x36 device. Tie DM[1:0] to V _{SS} if not used.
TCK	Input	IEEE 1149.1 clock input: This ball must be tied to V _{SS} if the JTAG function is not used.
TMS, TDI	Input	IEEE 1149.1 test inputs: These balls may be left as no connects if the JTAG function is not used.
WE#, REF#	Input	Command inputs: Sampled at the positive edge of CK, WE# and REF# (together with CS#) define the command to be executed.
RESET#	Input	Reset: RESET# is an active LOW CMOS input referenced to V _{SS} . RESET# assertion and deassertion are asynchronous. RESET# is a CMOS input defined with DC HIGH $\geq 0.8 \times V_{DDQ}$ and DC LOW $\leq 0.2 \times V_{DDQ}$.
ZQ	Input	External impedance: This signal is used to tune the device's output impedance and ODT. RZQ needs to be 240 Ω , where RZQ is a resistor from this signal to ground.
QKx, QKx#	Output	Output data clocks: QK and QK# are opposite-polarity output data clocks. They are free-running signals and during READ commands are edge-aligned with the DQs. For the x36 device, QK0, QK0# align with DQ[8:0]; QK1, QK1# align with DQ[17:9]; QK2, QK2# align with DQ[26:18]; QK3, QK3# align with DQ[35:27]. For the x18 device, QK0, QK0# align with DQ[8:0]; QK1, QK1# align with DQ[17:9].
QVLDx	Output	Data valid: The QVLD ball indicates that valid output data will be available on the subsequent rising clock edge. There is a single QVLD ball for the x18 device and two, QVLD0 and QVLD1, for the x36 device. QVLD0 aligns with DQ[17:0]; QVLD1 aligns with DQ[35:18].
MF	Input	Mirror function: The mirror function ball is a DC input used to create mirrored ballouts for simple dual-loaded clamshell mounting. If the ball is tied to V _{SS} , the address and command balls are in their true layout. If the ball is tied to V _{DDQ} , they are in the complement location. MF must be tied HIGH or LOW and cannot be left floating.
TDO	Output	IEEE 1149.1 test output: JTAG output. This ball may be left as no connect if the JTAG function is not used.

Table 3: Ball Descriptions (Continued)

Symbol	Type	Description
V _{DD}	Supply	Power supply: 1.35V nominal. See Table 8 (page 26) for range.
V _{DDQ}	Supply	DQ power supply: 1.2V nominal. Isolated on the device for improved noise immunity. See Table 8 (page 26) for range.
V _{EXT}	Supply	Power supply: 2.5V nominal. See Table 8 (page 26) for range.
V _{REF}	Supply	Input reference voltage: V _{DDQ} /2 nominal. Provides a reference voltage for the input buffers.
V _{SS}	Supply	Ground.
V _{SSQ}	Supply	DQ ground: Isolated on the device for improved noise immunity.
NC	–	No connect: These balls are not connected to the DRAM.
NF	–	No function: These balls are connected to the DRAM, but provide no functionality.

Package Dimensions

Figure 5: 168-Ball BGA



- Notes: 1. All dimensions are in millimeters.
2. Solder ball material: SAC302 (96.8% Sn, 3% Ag, 0.2% Cu).

Electrical Characteristics – I_{DD} Specifications

Table 4: I_{DD} Operating Conditions and Maximum Limits (Die Rev :A)

Notes 1–6 apply to the entire table

Description	Condition	Symbol	-093E	-107E	-125F	-125E	-125	Units	Notes
Standby current	^t CK = idle; All banks idle; No inputs toggling	I _{SB1} (V _{DD}) x18	125	125	125	125	125	mA	
		I _{SB1} (V _{DD}) x36	125	125	125	125	125		
		I _{SB1} (V _{EXT})	30	30	30	30	30		
Clock active standby current	CS# = 1; No commands; Bank address incremented and half address/data change once every four clock cycles	I _{SB2} (V _{DD}) x18	870	815	725	725	725	mA	
		I _{SB2} (V _{DD}) x36	895	835	740	740	740		
		I _{SB2} (V _{EXT})	30	30	30	30	30		
Operational current: BL2	BL = 2; Sequential bank access; Bank transitions once every ^t RC; Half address transitions once every ^t RC; Read followed by write sequence; Continuous data during WRITE commands	I _{DD1} (V _{DD}) x18	1175	1100	990	940	915	mA	
		I _{DD1} (V _{DD}) x36	1185	1110	1000	950	925		
		I _{DD1} (V _{EXT})	35	35	35	35	35		
Operational current: BL4	BL = 4; Sequential bank access; Bank transitions once every ^t RC; Half address transitions once every ^t RC; Read followed by write sequence; Continuous data during WRITE commands	I _{DD2} (V _{DD}) x18	1205	1130	1020	970	945	mA	
		I _{DD2} (V _{DD}) x36	1215	1140	1030	980	950		
		I _{DD2} (V _{EXT})	35	35	35	35	35		
Operational current: BL8	BL = 8; Sequential bank access; Bank transitions once every ^t RC; Half address transitions once every ^t RC; Read followed by write sequence; Continuous data during WRITE commands	I _{DD3} (V _{DD}) x18	1300	1200	1085	1030	1000	mA	
		I _{DD3} (V _{DD}) x36	NA	NA	N/A	NA	NA		
		I _{DD3} (V _{EXT})	35	35	35	35	35		
Burst refresh current	Sixteen bank cyclic refresh using Bank Address Control AREF protocol; Command bus remains in refresh for all sixteen banks; DQs are High-Z and at V _{DDQ} /2; Addresses are at V _{DDQ} /2	I _{REF1} (V _{DD}) x18	1550	1400	1230	1230	1230	mA	
		I _{REF1} (V _{DD}) x36	1570	1420	1245	1245	1245		
		I _{REF1} (V _{EXT})	80	75	70	70	70		
Distributed refresh current	Single bank refresh using Bank Address Control AREF protocol; Sequential bank access every 0.489μs; DQs are High-Z and at V _{DDQ} /2; Addresses are at V _{DDQ} /2	I _{REF2} (V _{DD}) x18	875	820	730	730	730	mA	
		I _{REF2} (V _{DD}) x36	900	840	745	745	745		
		I _{REF2} (V _{EXT})	30	30	30	30	30		

Table 4: I_{DD} Operating Conditions and Maximum Limits (Die Rev :A) (Continued)

Notes 1–6 apply to the entire table

Description	Condition	Symbol	-093E	-107E	-125F	-125E	-125	Units	Notes
Multibank refresh current: 4 bank refresh	Quad bank refresh using Multibank AREF protocol; BL = 4; Cyclic bank access; Subject to ^t SAW and ^t MMD specifications; DQs are High-Z and at V _{DDQ} /2; Bank addresses are at V _{DDQ} /2	I _{MBREF4} (V _{DD}) x18	2130	2030	1885	1885	1645	mA	
		I _{MBREF4} (V _{DD}) x36	2155	2050	1900	1900	1660		
		I _{MBREF4} (V _{EXT})	130	115	105	105	105		
Operating burst write current : BL2	BL = 2; Cyclic bank access; Half of address bits change every clock cycle; Continuous data; Measurement is taken during continuous WRITE	I _{DD2W} (V _{DD}) x18	2110	1910	1665	1665	1665	mA	
		I _{DD2W} (V _{DD}) x36	2290	2070	1805	1805	1805		
		I _{DD2W} (V _{EXT})	80	75	70	70	70		
Operating burst write current : BL4	BL = 4; Cyclic bank access; Half of address bits change every two clock cycles; Continuous data; Measurement is taken during continuous WRITE	I _{DD4W} (V _{DD}) x18	1730	1590	1395	1395	1395	mA	
		I _{DD4W} (V _{DD}) x36	1815	1665	1460	1460	1460		
		I _{DD4W} (V _{EXT})	55	55	50	50	50		
Operating burst write current :BL8	BL = 8; Cyclic bank access; Half of address bits change every four clock cycles; Continuous data; Measurement is taken during continuous WRITE	I _{DD8W} (V _{DD}) x18	1475	1335	1190	1190	1190	mA	
		I _{DD8W} (V _{DD}) x36	NA	NA	NA	NA	NA		
		I _{DD8W} (V _{EXT})	45	40	40	40	40		
Multibank write current: Dual bank write	BL = 4; Cyclic bank access using Dual Bank WRITE; Half of address bits change every two clock cycles; Continuous data; Measurement is taken during continuous WRITE	I _{DBWR} (V _{DD}) x18	2305	2170	1885	1885	1885	mA	
		I _{DBWR} (V _{DD}) x36	2400	2250	1960	1960	1960		
		I _{DBWR} (V _{EXT})	80	75	70	70	70		
Multibank write current: Quad bank write	BL = 4; Cyclic bank access using Quad Bank WRITE; Half of address bits change every two clock cycles; Continuous data; Measurement is taken during continuous WRITE; Subject to ^t SAW specification	I _{QBWR} (V _{DD}) x18	2965	2890	2525	2525	2525	mA	
		I _{QBWR} (V _{DD}) x36	3195	3000	2615	2615	2615		
		I _{QBWR} (V _{EXT})	130	115	100	100	100		
Operating burst read current example	BL = 2; Cyclic bank access; Half of address bits change every clock cycle; Continuous data; Measurement is taken during continuous READ	I _{DD2R} (V _{DD}) x18	2250	2045	1785	1785	1785	mA	
		I _{DD2R} (V _{DD}) x36	2395	2180	1895	1895	1895		
		I _{DD2R} (V _{EXT})	80	75	70	70	70		
Operating burst read current example	BL = 4; Cyclic bank access; Half of address bits change every two clock cycles; Continuous data; Measurement is taken during continuous READ	I _{DD4R} (V _{DD}) x18	1740	1595	1400	1400	1400	mA	
		I _{DD4R} (V _{DD}) x36	1835	1685	1475	1475	1475		
		I _{DD4R} (V _{EXT})	55	55	50	50	50		

Table 4: I_{DD} Operating Conditions and Maximum Limits (Die Rev :A) (Continued)

Notes 1–6 apply to the entire table

Description	Condition	Symbol	-093E	-107E	-125F	-125E	-125	Units	Notes
Operating burst read current example	BL = 8; Cyclic bank access; Half of address bits change every four clock cycles; Continuous data; Measurement is taken during continuous READ	I _{DD8R} (V _{DD}) x18	1450	1315	1175	1175	1175	mA	
		I _{DD8R} (V _{DD}) x36	NA	NA	NA	NA	NA		
		I _{DD8R} (V _{EXT})	45	40	40	40	40		

- Notes:
1. I_{DD} specifications are tested after the device is properly initialized. $0^{\circ}\text{C} \leq T_C \leq +95^{\circ}\text{C}$; $+1.28\text{V} \leq V_{DD} \leq +1.42\text{V}$, $+1.14\text{V} \leq V_{DDQ} \leq +1.26\text{V}$, $+2.38\text{V} \leq V_{EXT} \leq +2.63\text{V}$, $V_{REF} = V_{DDQ}/2$.
 2. I_{DD} measurements use t_{CK} (MIN), t_{RC} (MIN), and minimum data latency (RL and WL).
 3. Input slew rate is 1V/ns for single ended signals and 2V/ns for differential signals.
 4. Definitions for I_{DD} conditions:
 - LOW is defined as $V_{IN} \leq V_{IL(AC)MAX}$.
 - HIGH is defined as $V_{IN} \geq V_{IH(AC)MIN}$.
 - Continuous data is defined as half the DQ signals changing between HIGH and LOW every half clock cycle (twice per clock).
 - Continuous address is defined as half the address signals changing between HIGH and LOW every clock cycle (once per clock).
 - Sequential bank access is defined as the bank address incrementing by one every t_{RC} .
 - Cyclic bank access is defined as the bank address incrementing by one for each command access. For BL = 2 this is every clock, for BL = 4 this is every other clock, and for BL = 8 this is every fourth clock.
 5. CS# is HIGH unless a READ, WRITE, AREF, or MRS command is registered. CS# never transitions more than once per clock cycle.
 6. I_{DD} parameters are specified with ODT disabled.

Electrical Characteristics – I_{DD} Specifications

Table 5: I_{DD} Operating Conditions and Maximum Limits (Die Rev :B)

Notes 1–6 apply to the entire table

Description	Condition	Symbol	-093F	-093E	-107E	Units
Standby current	t ^{CK} = idle; All banks idle; No inputs toggling	I _{SB1} (V _{DD}) x18	225	225	225	mA
		I _{SB1} (V _{DD}) x36	225	225	225	
		I _{SB1} (V _{EXT})	55	55	55	
Clock active standby current	CS# = 1; No commands; Bank address incremented and half address/data change once every four clock cycles	I _{SB2} (V _{DD}) x18	605	605	570	mA
		I _{SB2} (V _{DD}) x36	625	625	585	
		I _{SB2} (V _{EXT})	55	55	55	
Operational current: BL2	BL = 2; Sequential bank access; Bank transitions once every t ^{RC} ; Half address transitions once every t ^{RC} ; Read followed by write sequence; Continuous data during WRITE commands	I _{DD1} (V _{DD}) x18	1105	1040	975	mA
		I _{DD1} (V _{DD}) x36	1115	1050	985	
		I _{DD1} (V _{EXT})	60	60	60	
Operational current: BL4	BL = 4; Sequential bank access; Bank transitions once every t ^{RC} ; Half address transitions once every t ^{RC} ; Read followed by write sequence; Continuous data during WRITE commands	I _{DD2} (V _{DD}) x18	1200	1130	1060	mA
		I _{DD2} (V _{DD}) x36	1210	1140	1070	
		I _{DD2} (V _{EXT})	60	60	60	
Operational current: BL8	BL = 8; Sequential bank access; Bank transitions once every t ^{RC} ; Half address transitions once every t ^{RC} ; Read followed by write sequence; Continuous data during WRITE commands	I _{DD3} (V _{DD}) x18	1160	1095	1015	mA
		I _{DD3} (V _{DD}) x36	NA	NA	NA	
		I _{DD3} (V _{EXT})	60	60	60	
Burst refresh current	Sixteen bank cyclic refresh using Bank Address Control AREF protocol; Command bus remains in refresh for all sixteen banks; DQs are High-Z and at V _{DDQ} /2; Addresses are at V _{DDQ} /2	I _{REF1} (V _{DD}) x18	1135	1135	1025	mA
		I _{REF1} (V _{DD}) x36	1150	1150	1040	
		I _{REF1} (V _{EXT})	115	115	110	
Distributed refresh current	Single bank refresh using Bank Address Control AREF protocol; Sequential bank access every 0.489μs; DQs are High-Z and at V _{DDQ} /2; Addresses are at V _{DDQ} /2	I _{REF2} (V _{DD}) x18	580	580	540	mA
		I _{REF2} (V _{DD}) x36	595	595	555	
		I _{REF2} (V _{EXT})	55	55	55	
Multibank refresh current: 4 bank refresh	Quad bank refresh using Multibank AREF protocol; BL = 4; Cyclic bank access; Subject to t ^{SAW} and t ^{MMD} specifications; DQs are High-Z and at V _{DDQ} /2; Bank addresses are at V _{DDQ} /2	I _{MBREF4} (V _{DD}) x18	1490	1490	1420	mA
		I _{MBREF4} (V _{DD}) x36	1510	1510	1435	
		I _{MBREF4} (V _{EXT})	185	185	165	
Operating burst write current : BL2	BL = 2; Cyclic bank access; Half of address bits change every clock cycle; Continuous data; Measurement is taken during continuous WRITE	I _{DD2W} (V _{DD}) x18	1655	1655	1500	mA
		I _{DD2W} (V _{DD}) x36	1810	1810	1635	
		I _{DD2W} (V _{EXT})	80	80	75	

Table 5: I_{DD} Operating Conditions and Maximum Limits (Die Rev :B) (Continued)

Notes 1–6 apply to the entire table

Description	Condition	Symbol	-093F	-093E	-107E	Units
Operating burst write current : BL4	BL = 4; Cyclic bank access; Half of address bits change every two clock cycles; Continuous data; Measurement is taken during continuous WRITE	I _{DD4W} (V _{DD}) x18	1515	1515	1395	mA
		I _{DD4W} (V _{DD}) x36	1595	1595	1465	
		I _{DD4W} (V _{EXT})	75	75	70	
Operating burst write current :BL8	BL = 8; Cyclic bank access; Half of address bits change every four clock cycles; Continuous data; Measurement is taken during continuous WRITE	I _{DD8W} (V _{DD}) x18	1140	1140	1040	mA
		I _{DD8W} (V _{DD}) x36	NA	NA	NA	
		I _{DD8W} (V _{EXT})	70	70	65	
Multibank write current: Dual bank write	BL = 4; Cyclic bank access using Dual Bank WRITE; Half of address bits change every two clock cycles; Continuous data; Measurement is taken during continuous WRITE	I _{DBWR} (V _{DD}) x18	2005	2005	1890	mA
		I _{DBWR} (V _{DD}) x36	2090	2090	1960	
		I _{DBWR} (V _{EXT})	115	115	110	
Multibank write current: Quad bank write	BL = 4; Cyclic bank access using Quad Bank WRITE; Half of address bits change every two clock cycles; Continuous data; Measurement is taken during continuous WRITE; Subject to t _{SAW} specification	I _{QBWR} (V _{DD}) x18	2620	2620	2565	mA
		I _{QBWR} (V _{DD}) x36	2840	2840	2665	
		I _{QBWR} (V _{EXT})	200	200	175	
Operating burst read current example	BL = 2; Cyclic bank access; Half of address bits change every clock cycle; Continuous data; Measurement is taken during continuous READ	I _{DD2R} (V _{DD}) x18	1715	1715	1560	mA
		I _{DD2R} (V _{DD}) x36	1835	1835	1670	
		I _{DD2R} (V _{EXT})	80	80	75	
Operating burst read current example	BL = 4; Cyclic bank access; Half of address bits change every two clock cycles; Continuous data; Measurement is taken during continuous READ	I _{DD4R} (V _{DD}) x18	1510	1510	1380	mA
		I _{DD4R} (V _{DD}) x36	1595	1595	1465	
		I _{DD4R} (V _{EXT})	75	75	70	
Operating burst read current example	BL = 8; Cyclic bank access; Half of address bits change every four clock cycles; Continuous data; Measurement is taken during continuous READ	I _{DD8R} (V _{DD}) x18	1135	1135	1040	mA
		I _{DD8R} (V _{DD}) x36	NA	NA	NA	
		I _{DD8R} (V _{EXT})	70	70	65	

- Notes:
1. I_{DD} specifications are tested after the device is properly initialized. $0^{\circ}\text{C} \leq T_C \leq +95^{\circ}\text{C}$; $+1.28\text{V} \leq V_{DD} \leq +1.42\text{V}$, $+1.14\text{V} \leq V_{DDQ} \leq +1.26\text{V}$, $+2.38\text{V} \leq V_{EXT} \leq +2.63\text{V}$, $V_{REF} = V_{DDQ}/2$.
 2. I_{DD} measurements use t_{CK} (MIN), t_{RC} (MIN), and minimum data latency (RL and WL).
 3. Input slew rate is 1 V/ns for single ended signals and 2 V/ns for differential signals.
 4. Definitions for I_{DD} conditions:
 - LOW is defined as $V_{IN} \leq V_{IL(AC)MAX}$.
 - HIGH is defined as $V_{IN} \geq V_{IH(AC)MIN}$.
 - Continuous data is defined as half the DQ signals changing between HIGH and LOW every half clock cycle (twice per clock).
 - Continuous address is defined as half the address signals changing between HIGH and LOW every clock cycle (once per clock).
 - Sequential bank access is defined as the bank address incrementing by one every t_{RC} .
 - Cyclic bank access is defined as the bank address incrementing by one for each command access. For BL = 2 this is every clock, for BL = 4 this is every other clock, and for BL = 8 this is every fourth clock.
 5. CS# is HIGH unless a READ, WRITE, AREF, or MRS command is registered. CS# never transitions more than once per clock cycle.
 6. I_{DD} parameters are specified with ODT disabled.

Electrical Specifications – Absolute Ratings and I/O Capacitance

Absolute Maximum Ratings

Stresses greater than those listed may cause permanent damage to the device. This is a stress rating only, and functional operation of the device at these or any other conditions outside those indicated in the operational sections of this specification is not implied. Exposure to absolute maximum rating conditions for extended periods may adversely affect reliability.

Table 6: Absolute Maximum Ratings

Symbol	Parameter	Min	Max	Units
V_{DD}	V_{DD} supply voltage relative to V_{SS}	-0.4	1.975	V
V_{DDQ}	Voltage on V_{DDQ} supply relative to V_{SS}	-0.4	1.66	V
V_{IN}, V_{OUT}	Voltage on any ball relative to V_{SS}	-0.4	1.66	V
V_{EXT}	Voltage on V_{EXT} supply relative to V_{SS}	-0.4	2.8	V

Input/Output Capacitance

Table 7: Input/Output Capacitance

Notes 1 and 2 apply to entire table

Capacitance Parameters	Symbol	RL3-2133		RL3-1866		RL3-1600		Units	Notes
		Min	Max	Min	Max	Min	Max		
CK/CK#	C_{CK}	1.3	2.1	1.3	2.1	1.3	2.2	pF	
ΔC : CK to CK#	C_{DCK}	0	0.15	0	0.15	0	0.15	pF	
Single-ended I/O: DQ, DM	C_{IO}	1.9	2.9	1.9	3.0	2.0	3.1	pF	3
Input strobe: DK/DK#	C_{IO}	1.9	2.9	1.9	3.0	2.0	3.1	pF	
Output strobe: QK/QK#, QVLD	C_{IO}	1.9	2.9	1.9	3.0	2.0	3.1	pF	
ΔC : DK to DK#	C_{DDK}	0	0.15	0	0.15	0	0.15	pF	
ΔC : QK to QK#	C_{DQK}	0	0.15	0	0.15	0	0.15	pF	
ΔC : DQ to QK or DQ to DK	C_{DIO}	-0.5	0.3	-0.5	0.3	-0.5	0.3	pF	4
Inputs (CMD, ADDR)	C_I	1.25	2.25	1.25	2.25	1.25	2.25	pF	5
ΔC : CMD_ADDR to CK	$C_{DI_CMD_ADDR}$	-0.5	0.3	-0.5	0.3	-0.4	0.4	pF	6
JTAG balls	C_{JTAG}	1.5	4.5	1.5	4.5	1.5	4.5	pF	7
RESET#, MF balls	C_I	-	3.0	-	3.0	-	3.0	pF	

- Notes:
- $+1.28V \leq V_{DD} \leq +1.42V$, $+1.14V \leq V_{DDQ} \leq 1.26V$, $+2.38V \leq V_{EXT} \leq +2.63V$, $V_{REF} = V_{SS}$, $f = 100$ MHz, $T_C = 25^\circ C$, $V_{OUT(DC)} = 0.5 \times V_{DDQ}$, V_{OUT} (peak-to-peak) = 0.1V.
 - Capacitance is not tested on ZQ ball.
 - DM input is grouped with the I/O balls, because they are matched in loading.
 - $C_{DIO} = C_{IO(DQ)} - 0.5 \times (C_{IO} [QK] + C_{IO} [QK\#])$.
 - Includes CS#, REF#, WE#, A[19:0], and BA[3:0].
 - $C_{DI_CMD_ADDR} = C_I$ (CMD_ADDR) - $0.5 \times (C_{CK} [CK] + C_{CK} [CK\#])$.
 - JTAG balls are tested at 50 MHz.

AC and DC Operating Conditions

Table 8: DC Electrical Characteristics and Operating Conditions

Note 1 applies to the entire table; Unless otherwise noted: $0^{\circ}\text{C} \leq T_C \leq +95^{\circ}\text{C}$; $+1.28\text{V} \leq V_{DD} \leq +1.42\text{V}$

Description	Symbol	Min	Max	Units	Notes
Supply voltage	V_{EXT}	2.38	2.63	V	
Supply voltage	V_{DD}	1.28	1.42	V	
Isolated output buffer supply	V_{DDQ}	1.14	1.26	V	
Reference voltage	V_{REF}	$0.49 \times V_{DDQ}$	$0.51 \times V_{DDQ}$	V	2, 3
Input HIGH (logic 1) voltage	$V_{IH(DC)}$	$V_{REF} + 0.10$	V_{DDQ}	V	
Input LOW (logic 0) voltage	$V_{IL(DC)}$	V_{SS}	$V_{REF} - 0.10$	V	
Input leakage current: Any input $0\text{V} \leq V_{IN} \leq V_{DD}$, V_{REF} ball $0\text{V} \leq V_{IN} \leq 1.1\text{V}$ (All other balls not under test = 0V)	I_{LI}	-2	2	μA	
Reference voltage current (All other balls not under test = 0V)	I_{REF}	-5	5	μA	

- Notes:
1. All voltages referenced to V_{SS} (GND).
 2. The nominal value of V_{REF} is expected to be $0.5 \times V_{DDQ}$ of the transmitting device. V_{REF} is expected to track variations in V_{DDQ} .
 3. Peak-to-peak noise (non-common mode) on V_{REF} may not exceed $\pm 2\%$ of the DC value. DC values are determined to be less than 20 MHz. Peak-to-peak AC noise on V_{REF} should not exceed $\pm 2\%$ of $V_{REF(DC)}$. Thus, from $V_{DDQ}/2$, V_{REF} is allowed $\pm 2\% V_{DDQ}/2$ for DC error and an additional $\pm 2\% V_{DDQ}/2$ for AC noise. The measurement is to be taken at the nearest V_{REF} bypass capacitor.

Table 9: Input AC Logic Levels

Notes 1-3 apply to entire table; Unless otherwise noted: $0^{\circ}\text{C} \leq T_C \leq +95^{\circ}\text{C}$; $+1.28\text{V} \leq V_{DD} \leq +1.42\text{V}$

Description	Symbol	Min	Max	Units
Input HIGH (logic 1) voltage	$V_{IH(AC150)}$	$V_{REF} + 0.15$	-	V
Input HIGH (logic 1) voltage	$V_{IH(AC120)}$	$V_{REF} + 0.12$	-	V
Input LOW (logic 0) voltage	$V_{IL(AC120)}$	-	$V_{REF} - 0.12$	V
Input LOW (logic 0) voltage	$V_{IL(AC150)}$	-	$V_{REF} - 0.15$	V

- Notes:
1. All voltages referenced to V_{SS} (GND).
 2. The receiver will effectively switch as a result of the signal crossing the AC input level, and will remain in that state as long as the signal does not ring back above/below the DC input LOW/HIGH level.
 3. Single-ended input slew rate = 1V/ns ; maximum input voltage swing under test is 900mV (peak-to-peak).

Figure 6: Single-Ended Input Signal



AC Overshoot/Undershoot Specifications

Table 10: Control and Address Balls

Parameter	RL3-2133	RL3-1866	RL3-1600
Maximum peak amplitude allowed for overshoot area	0.4V	0.4V	0.4V
Maximum peak amplitude allowed for undershoot area	0.4V	0.4V	0.4V
Maximum overshoot area above V_{DDQ}	0.25 Vns	0.28 Vns	0.33 Vns
Maximum undershoot area below V_{SS}/V_{SSQ}	0.25 Vns	0.28 Vns	0.33 Vns

Table 11: Clock, Data, Strobe, and Mask Balls

Parameter	RL3-2133	RL3-1866	RL3-1600
Maximum peak amplitude allowed for overshoot area	0.4V	0.4V	0.4V
Maximum peak amplitude allowed for undershoot area	0.4V	0.4V	0.4V
Maximum overshoot area above V_{DDQ}	0.10 Vns	0.11 Vns	0.13 Vns
Maximum undershoot area below V_{SS}/V_{SSQ}	0.10 Vns	0.11 Vns	0.13 Vns

Figure 7: Overshoot



Figure 8: Undershoot



Table 12: Differential Input Operating Conditions (CK, CK# and DKx, DKx#)

Notes 1 and 2 apply to entire table

Parameter/Condition	Symbol	Min	Max	Units	Notes
Differential input voltage logic HIGH – slew	$V_{IH,diff_slew}$	+200	n/a	mV	3
Differential input voltage logic LOW – slew	$V_{IL,diff_slew}$	n/a	-200	mV	3
Differential input voltage logic HIGH	$V_{IH,diff(AC)}$	$2 \times (V_{IH(AC)} - V_{REF})$	V_{DDQ}	mV	4
Differential input voltage logic LOW	$V_{IL,diff(AC)}$	V_{SSQ}	$2 \times (V_{IL(AC)} - V_{REF})$	mV	5
Differential input crossing voltage relative to $V_{DD}/2$	V_{IX}	$V_{REF(DC)} - 150$	$V_{REF(DC)} + 150$	mV	6
Single-ended HIGH level	V_{SEH}	$V_{IH(AC)}$	V_{DDQ}	mV	4
Single-ended LOW level	V_{SEL}	V_{SSQ}	$V_{IL(AC)}$	mV	5

- Notes:
1. CK/CK# and DKx/DKx# are referenced to V_{DDQ} and V_{SSQ} .
 2. Differential input slew rate = 2 V/ns.
 3. Defines slew rate reference points, relative to input crossing voltages.
 4. Maximum limit is relative to single-ended signals; overshoot specifications are applicable.
 5. Minimum limit is relative to single-ended signals; undershoot specifications are applicable.
 6. The typical value of V_{IX} is expected to be about $0.5 \times V_{DDQ}$ of the transmitting device and V_{IX} is expected to track variations in V_{DDQ} . V_{IX} indicates the voltage at which differential input signals must cross.

Figure 9: V_{IX} for Differential Signals



Figure 10: Single-Ended Requirements for Differential Signals

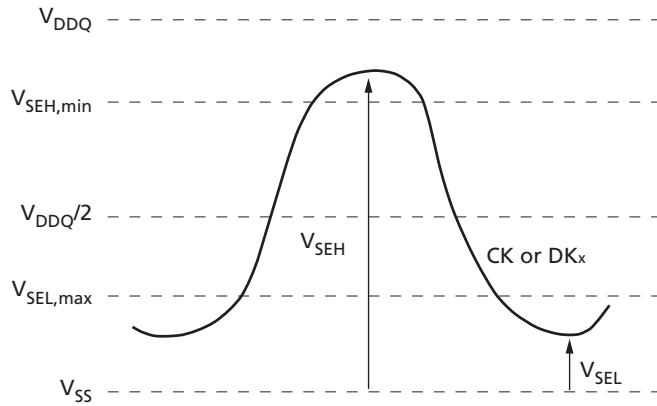

Figure 11: Definition of Differential AC Swing and t_{DVAC}

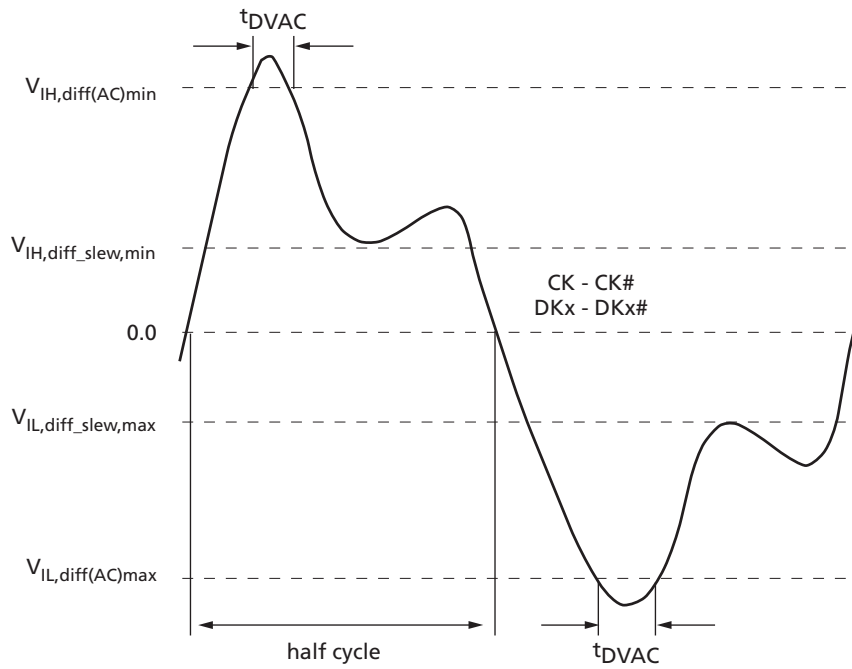

Table 13: Allowed Time Before Ringback (^tDVAC) for CK, CK#, DKx, and DKx#

Slew Rate (V/ns)	MIN ^t DVAC (ps) at V _{IH} /V _{IL,diff(AC)}
>4.0	175
4.0	170
3.0	167
2.0	163
1.9	162
1.6	161
1.4	159
1.2	155
1.0	150
<1.0	150

Slew Rate Definitions for Single-Ended Input Signals

Setup (^tIS and ^tDS) nominal slew rate for a rising signal is defined as the slew rate between the last crossing of V_{REF} and the first crossing of V_{IH(AC)min}. Setup (^tIS and ^tDS) nominal slew rate for a falling signal is defined as the slew rate between the last crossing of V_{REF} and the first crossing of V_{IL(AC)max}.

Hold (^tIH and ^tDH) nominal slew rate for a rising signal is defined as the slew rate between the last crossing of V_{IL(DC)max} and the first crossing of V_{REF}. Hold (^tIH and ^tDH) nominal slew rate for a falling signal is defined as the slew rate between the last crossing of V_{IH(DC)min} and the first crossing of V_{REF} (see Figure 12 (page 32)).

Table 14: Single-Ended Input Slew Rate Definition

Input Slew Rates (Linear Signals)		Measured		Calculation
Input	Edge	From	To	
Setup	Rising	V _{REF}	V _{IH(AC)min}	$[V_{IH(AC)min} - V_{REF}]/\Delta TRS$
	Falling	V _{REF}	V _{IL(AC)max}	$[V_{REF} - V_{IL(AC)max}]/\Delta TFS$
Hold	Rising	V _{IL(DC)max}	V _{REF}	$[V_{REF} - V_{IL(DC)max}]/\Delta TRH$
	Falling	V _{IH(DC)min}	V _{REF}	$[V_{IH(DC)min} - V_{REF}]/\Delta TFH$

Figure 12: Nominal Slew Rate Definition for Single-Ended Input Signals



Slew Rate Definitions for Differential Input Signals

Input slew rate for differential signals (CK, CK# and DKx, DKx#) are defined and measured as shown in the following two tables. The nominal slew rate for a rising signal is defined as the slew rate between $V_{IL,diff,max}$ and $V_{IH,diff,min}$. The nominal slew rate for a falling signal is defined as the slew rate between $V_{IH,diff,min}$ and $V_{IL,diff,max}$.

Table 15: Differential Input Slew Rate Definition

Differential Input Slew Rates (Linear Signals)		Measured		Calculation
Input	Edge	From	To	
CK and DK reference	Rising	$V_{IL,diff_slew,max}$	$V_{IH,diff_slew,min}$	$[V_{IH,diff_slew,min} - V_{IL,diff_slew,max}] / \Delta TR_{diff}$
	Falling	$V_{IH,diff_slew,min}$	$V_{IL,diff_slew,max}$	$[V_{IH,diff_slew,min} - V_{IL,diff_slew,max}] / \Delta TF_{diff}$

Figure 13: Nominal Differential Input Slew Rate Definition for CK, CK#, DKx, and DKx#



ODT Characteristics

ODT effective resistance, R_{TT} , is defined by MR1[4:2]. ODT is applied to the DQ, DM, and DKx, DKx# balls. The individual pull-up and pull-down resistors (R_{TTPU} and R_{TTPD}) are defined as follows:

$$R_{TTPU} = (V_{DDQ} - V_{OUT}) / |I_{OUT}|, \text{ under the condition that } R_{TTPD} \text{ is turned off}$$

$$R_{TTPD} = (V_{OUT}) / |I_{OUT}|, \text{ under the condition that } R_{TTPU} \text{ is turned off}$$

Figure 14: ODT Levels and I-V Characteristics



Table 16: ODT DC Electrical Characteristics

Parameter/Condition	Symbol	Min	Nom	Max	Units	Notes
R_{TT} effective impedance from $V_{IL(AC)}$ to $V_{IH(AC)}$	R_{TT_EFF}	See Table 17 (page 35).				1, 2
Deviation of V_M with respect to $V_{DDQ}/2$	ΔV_m	-5	-	+5	%	3

- Notes:
1. Tolerance limits are applicable after proper ZQ calibration has been performed at a stable temperature and voltage. Refer to ODT Sensitivity (page 36) if either the temperature or voltage changes after calibration.
 2. Measurement definition for R_{TT} : Apply $V_{IH(AC)}$ to ball under test and measure current $I[V_{IH(AC)}]$, then apply $V_{IL(AC)}$ to ball under test and measure current $I[V_{IL(AC)}]$:

$$R_{TT} = \frac{V_{IH(AC)} - V_{IL(AC)}}{|I[V_{IH(AC)}] - I[V_{IL(AC)}]|}$$

3. Measure voltage (V_M) at the tested ball with no load:

$$\Delta VM = \left(\frac{2 \times VM}{V_{DDQ}} - 1 \right) \times 100$$

ODT Resistors

The on-die termination resistance is selected by MR1[4:2]. The following table provides an overview of the ODT DC electrical characteristics. The values provided are not speci-

fication requirements; however, they can be used as design guidelines to indicate what R_{TT} is targeted to provide:

- R_{TT} 120 Ω is made up of $R_{TT120(PD240)}$ and $R_{TT120(PU240)}$.
- R_{TT} 60 Ω is made up of $R_{TT60(PD120)}$ and $R_{TT60(PU120)}$.
- R_{TT} 40 Ω is made up of $R_{TT40(PD80)}$ and $R_{TT40(PU80)}$.

Table 17: R_{TT} Effective Impedances

R_{TT}	Resistor	V_{out}	Min	Nom	Max	Units
120 Ω	$R_{TT120(PD240)}$	$0.2 \times V_{DDQ}$	0.6	1.0	1.1	RZQ/1
		$0.5 \times V_{DDQ}$	0.9	1.0	1.1	RZQ/1
		$0.8 \times V_{DDQ}$	0.9	1.0	1.4	RZQ/1
	$R_{TT120(PU240)}$	$0.2 \times V_{DDQ}$	0.9	1.0	1.4	RZQ/1
		$0.5 \times V_{DDQ}$	0.9	1.0	1.1	RZQ/1
		$0.8 \times V_{DDQ}$	0.6	1.0	1.1	RZQ/1
120 Ω		$V_{IL(AC)}$ to $V_{IH(AC)}$	0.9	1.0	1.6	RZQ/2
60 Ω	$R_{TT60(PD120)}$	$0.2 \times V_{DDQ}$	0.6	1.0	1.1	RZQ/2
		$0.5 \times V_{DDQ}$	0.9	1.0	1.1	RZQ/2
		$0.8 \times V_{DDQ}$	0.9	1.0	1.4	RZQ/2
	$R_{TT60(PU120)}$	$0.2 \times V_{DDQ}$	0.9	1.0	1.4	RZQ/2
		$0.5 \times V_{DDQ}$	0.9	1.0	1.1	RZQ/2
		$0.8 \times V_{DDQ}$	0.6	1.0	1.1	RZQ/2
60 Ω		$V_{IL(AC)}$ to $V_{IH(AC)}$	0.9	1.0	1.6	RZQ/4
40 Ω	$R_{TT40(PD80)}$	$0.2 \times V_{DDQ}$	0.6	1.0	1.1	RZQ/3
		$0.5 \times V_{DDQ}$	0.9	1.0	1.1	RZQ/3
		$0.8 \times V_{DDQ}$	0.9	1.0	1.4	RZQ/3
	$R_{TT40(PU80)}$	$0.2 \times V_{DDQ}$	0.9	1.0	1.4	RZQ/3
		$0.5 \times V_{DDQ}$	0.9	1.0	1.1	RZQ/3
		$0.8 \times V_{DDQ}$	0.6	1.0	1.1	RZQ/3
40 Ω		$V_{IL(AC)}$ to $V_{IH(AC)}$	0.9	1.0	1.6	RZQ/6

ODT Sensitivity

If either temperature or voltage changes after I/O calibration, then the tolerance limits listed in Table 16 (page 34) and Table 17 (page 35) can be expected to widen according to Table 18 (page 36) and Table 19 (page 36).

Table 18: ODT Sensitivity Definition

Symbol	Min	Max	Units
R_{TT}	$0.9 - dR_{TTdT} \times DT - dR_{TTdV} \times DV $	$1.6 + dR_{TTdT} \times DT + dR_{TTdV} \times DV $	RZQ/(2,4,6)

Note: 1. $DT = T - T(@ \text{ calibration})$, $DV = V_{DDQ} - V_{DDQ}(@ \text{ calibration})$ or $V_{DD} - V_{DD}(@ \text{ calibration})$.

Table 19: ODT Temperature and Voltage Sensitivity

Change	Min	Max	Units
dR_{TTdT}	0	1.5	%/°C
dR_{TTdV}	0	0.15	%/mV

Output Driver Impedance

The output driver impedance is selected by MR1[1:0] during initialization. The selected value is able to maintain the tight tolerances specified if proper ZQ calibration is performed.

Output specifications refer to the default output driver unless specifically stated otherwise. A functional representation of the output buffer is shown below. The output driver impedance R_{ON} is defined by the value of the external reference resistor RZQ as follows:

- $R_{ON,x} = RZQ/y$ (with $RZQ = 240\Omega \pm 1\%$; $x = 40\Omega$ or 60Ω with $y = 6$ or 4 , respectively)

The individual pull-up and pull-down resistors ($R_{ON(PU)}$ and $R_{ON(PD)}$) are defined as follows:

- $R_{ON(PU)} = (V_{DDQ} - V_{OUT})/|I_{OUT}|$, when $R_{ON(PD)}$ is turned off
- $R_{ON(PD)} = (V_{OUT})/|I_{OUT}|$, when $R_{ON(PU)}$ is turned off

Figure 15: Output Driver



Table 20: Driver Pull-Up and Pull-Down Impedance Calculations

R_{ON}		Min	Nom	Max	Units
$RZQ/6 = (240\Omega \pm 1\%)/6$		39.6	40	40.4	Ω
$RZQ/4 = (240\Omega \pm 1\%)/4$		59.4	60	60.6	Ω
Driver	V_{OUT}	Min	Nom	Max	Units
40 Ω pull-down	$0.2 \times V_{DDQ}$	24	40	44	Ω
	$0.5 \times V_{DDQ}$	36	40	44	Ω
	$0.8 \times V_{DDQ}$	36	40	56	Ω
40 Ω pull-up	$0.2 \times V_{DDQ}$	36	40	56	Ω
	$0.5 \times V_{DDQ}$	36	40	44	Ω
	$0.8 \times V_{DDQ}$	24	40	44	Ω
60 Ω pull-down	$0.2 \times V_{DDQ}$	36	60	66	Ω
	$0.5 \times V_{DDQ}$	54	60	66	Ω
	$0.8 \times V_{DDQ}$	54	60	84	Ω
60 Ω pull-up	$0.2 \times V_{DDQ}$	54	60	84	Ω
	$0.5 \times V_{DDQ}$	54	60	66	Ω
	$0.8 \times V_{DDQ}$	36	60	66	Ω

Output Driver Sensitivity

If either the temperature or the voltage changes after ZQ calibration, then the tolerance limits listed in Table 20 (page 37) can be expected to widen according to Table 21 (page 38) and Table 22 (page 38).

Table 21: Output Driver Sensitivity Definition

Symbol	Min	Max	Units
$R_{ON(PD)} @ 0.2 \times V_{DDQ}$	$0.6 - dR_{ONdTH} \times DT - dR_{ONdVH} \times DV$	$1.1 + dR_{ONdTH} \times DT + dR_{ONdVH} \times DV$	RZQ/(6, 4)
$R_{ON(PD)} @ 0.5 \times V_{DDQ}$	$0.9 - dR_{ONdTM} \times DT - dR_{ONdVM} \times DV$	$1.1 + dR_{ONdTM} \times DT + dR_{ONdVM} \times DV$	RZQ/(6, 4)
$R_{ON(PD)} @ 0.8 \times V_{DDQ}$	$0.9 - dR_{ONdTL} \times DT - dR_{ONdVL} \times DV$	$1.4 + dR_{ONdTL} \times DT + dR_{ONdVL} \times DV$	RZQ/(6, 4)
$R_{ON(PU)} @ 0.2 \times V_{DDQ}$	$0.9 - dR_{ONdTH} \times DT - dR_{ONdVH} \times DV$	$1.4 + dR_{ONdTH} \times DT + dR_{ONdVH} \times DV$	RZQ/(6, 4)
$R_{ON(PU)} @ 0.5 \times V_{DDQ}$	$0.9 - dR_{ONdTM} \times DT - dR_{ONdVM} \times DV$	$1.1 + dR_{ONdTM} \times DT + dR_{ONdVM} \times DV$	RZQ/(6, 4)
$R_{ON(PU)} @ 0.8 \times V_{DDQ}$	$0.6 - dR_{ONdTL} \times DT - dR_{ONdVL} \times DV$	$1.1 + dR_{ONdTL} \times DT + dR_{ONdVL} \times DV$	RZQ/(6, 4)

Note: 1. $DT = T - T(@ \text{calibration})$, $DV = V_{DDQ} - V_{DDQ}(@ \text{calibration})$ or $V_{DD} - V_{DD}(@ \text{calibration})$.

Table 22: Output Driver Voltage and Temperature Sensitivity

Change	Min	Max	Unit
dR_{ONdTM}	0	1.5	%/°C
dR_{ONdVM}	0	0.15	%/mV
dR_{ONdTL}	0	1.5	%/°C
dR_{ONdVL}	0	0.15	%/mV
dR_{ONdTH}	0	1.5	%/°C
dR_{ONdVH}	0	0.15	%/mV

Output Characteristics and Operating Conditions

Table 23: Single-Ended Output Driver Characteristics

Note 1 and 2 apply to entire table

Parameter/Condition	Symbol	Min	Max	Units	Notes
Output leakage current; DQ are disabled; Any output ball $0V \leq V_{OUT} \leq V_{DDQ}$; ODT is disabled; All other balls not under test = 0V	I_{OZ}	-5	5	μA	
Output slew rate: Single-ended; For rising and falling edges, measures between $V_{OL(AC)} = V_{REF} - 0.1 \times V_{DDQ}$ and $V_{OH(AC)} = V_{REF} + 0.1 \times V_{DDQ}$	SRQ_{SE}	2.5	6	V/ns	4, 5
Single-ended DC high-level output voltage	$V_{OH(DC)}$	$0.8 \times V_{DDQ}$		V	6
Single-ended DC mid-point level output voltage	$V_{OM(DC)}$	$0.5 \times V_{DDQ}$		V	6
Single-ended DC low-level output voltage	$V_{OL(DC)}$	$0.2 \times V_{DDQ}$		V	6
Single-ended AC high-level output voltage	$V_{OH(AC)}$	$V_{TT} + 0.1 \times V_{DDQ}$		V	7, 8, 9
Single-ended AC low-level output voltage	$V_{OL(AC)}$	$V_{TT} - 0.1 \times V_{DDQ}$		V	7, 8, 9
Impedance delta between pull-up and pull-down for DQ and QVLD	MM_{PUPD}	-10	10	%	3
Test load for AC timing and output slew rates	Output to V_{TT} ($V_{DDQ}/2$) via 25 Ω resistor				9

- Notes:
- All voltages are referenced to V_{SS} .
 - RZQ is 240 Ω ($\pm 1\%$) and is applicable after proper ZQ calibration has been performed at a stable temperature and voltage.
 - Measurement definition for mismatch between pull-up and pull-down (MM_{PUPD}). Measure both $R_{ON(PU)}$ and $R_{ON(PD)}$ at $0.5 \times V_{DDQ}$:

$$MM_{PUPD} = \frac{R_{onPU} - R_{onPD}}{R_{onNOM}} \times 100$$

- The 6 V/ns maximum is applicable for a single DQ signal when it is switching either from HIGH to LOW or LOW to HIGH while the remaining DQ signals in the same byte lane are either all static or switching the opposite direction. For all other DQ signal switching combinations, the maximum limit of 6 V/ns is reduced to 5 V/ns.
- See Table 25 (page 43) for output slew rate.
- See the Driver Pull-Up and Pull-Down Impedance Calculations table for IV curve linearity. Do not use AC test load.
- $V_{TT} = V_{DDQ}/2$.
- See Figure 16 (page 41) for an example of a single-ended output signal.
- See Figure 18 (page 42) for the test load configuration.

Table 24: Differential Output Driver Characteristics

Notes 1 and 2 apply to entire table

Parameter/Condition	Symbol	Min	Max	Units	Notes
Output leakage current; DQ are disabled; Any output ball $0V \leq V_{OUT} \leq V_{DDQ}$; ODT is disabled; All other balls not under test = 0V	I_{OZ}	-5	5	μA	
Output slew rate: Differential; For rising and falling edges, measures between $V_{OL,diff(AC)} = -0.2 \times V_{DDQ}$ and $V_{OH,diff(AC)} = +0.2 \times V_{DDQ}$	SRQ_{diff}	5	12	V/ns	5
Output differential cross-point voltage	$V_{OX(AC)}$	$V_{REF} - 150$	$V_{REF} + 150$	mV	6
Differential high-level output voltage	$V_{OH,diff(AC)}$	$+0.2 \times V_{DDQ}$		V	6
Differential low-level output voltage	$V_{OL,diff(AC)}$	$-0.2 \times V_{DDQ}$		V	6
Delta resistance between pull-up and pull-down for QK/QK#	MM_{PUPD}	-10	10	%	3
Test load for AC timing and output slew rates	Output to V_{TT} ($V_{DDQ}/2$) via 25 Ω resistor				4

- Notes:
1. All voltages are referenced to V_{SS} .
 2. RZQ is 240 Ω ($\pm 1\%$) and is applicable after proper ZQ calibration has been performed at a stable temperature and voltage.
 3. Measurement definition for mismatch between pull-up and pull-down (MM_{PUPD}). Measure both $R_{ON(PU)}$ and $R_{ON(PD)}$ at $0.5 \times V_{DDQ}$:

$$MM_{PUPD} = \frac{R_{onPU} - R_{onPD}}{R_{onNOM}} \times 100$$

4. See Figure 18 (page 42) for the test load configuration.
5. See Table 26 (page 44) for the output slew rate.
6. See Figure 17 (page 42) for an example of a differential output signal.

Figure 16: DQ Output Signal

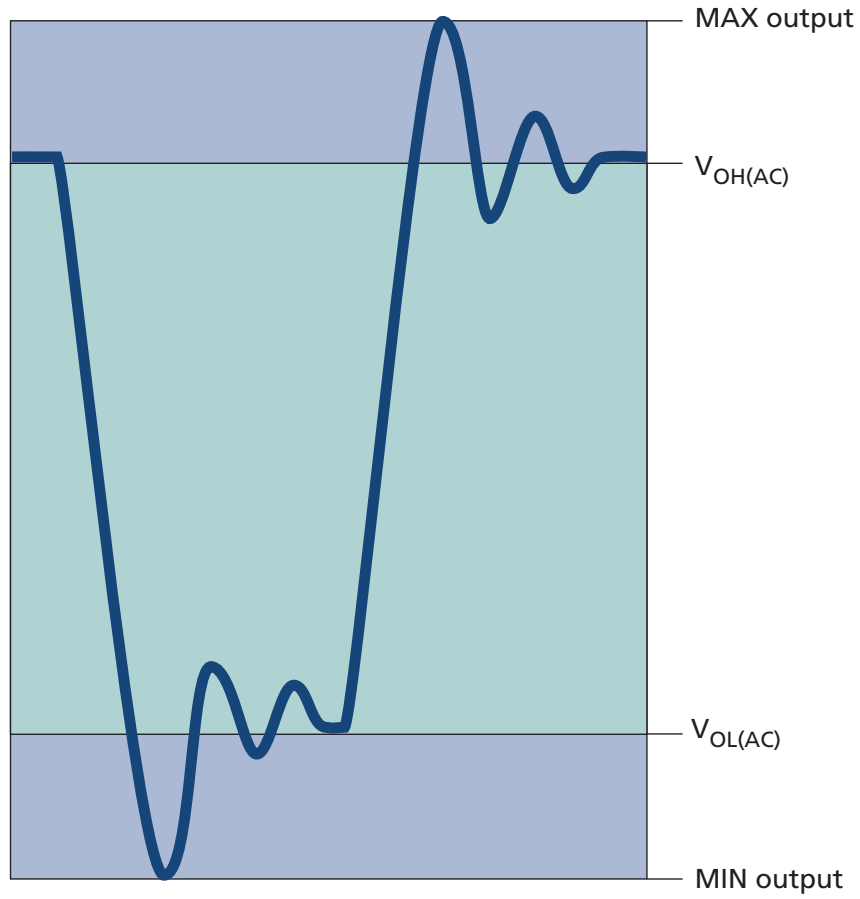

Figure 17: Differential Output Signal



Reference Output Load

The following figure represents the effective reference load of 25Ω used in defining the relevant device AC timing parameters as well as the output slew rate measurements. It is not intended to be a precise representation of a particular system environment or a depiction of the actual load presented by a production tester. System designers should use IBIS or other simulation tools to correlate the timing reference load to a system environment.

Figure 18: Reference Output Load for AC Timing and Output Slew Rate

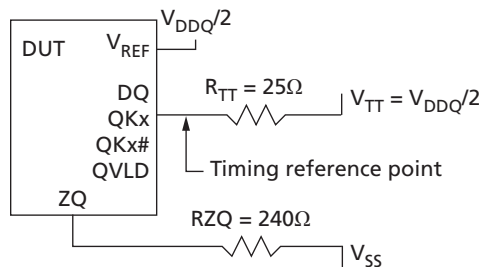

Slew Rate Definitions for Single-Ended Output Signals

The single-ended output driver is summarized in the following table. With the reference load for timing measurements, the output slew rate for falling and rising edges is defined and measured between $V_{OL(AC)}$ and $V_{OH(AC)}$ for single-ended signals.

Table 25: Single-Ended Output Slew Rate Definition

Single-Ended Output Slew Rates (Linear Signals)		Measured		Calculation
Output	Edge	From	To	
DQ and QVLD	Rising	$V_{OL(AC)}$	$V_{OH(AC)}$	$\frac{V_{OH(AC)} - V_{OL(AC)}}{\Delta TR_{SE}}$
	Falling	$V_{OH(AC)}$	$V_{OL(AC)}$	$\frac{V_{OH(AC)} - V_{OL(AC)}}{\Delta TF_{SE}}$

Figure 19: Nominal Slew Rate Definition for Single-Ended Output Signals

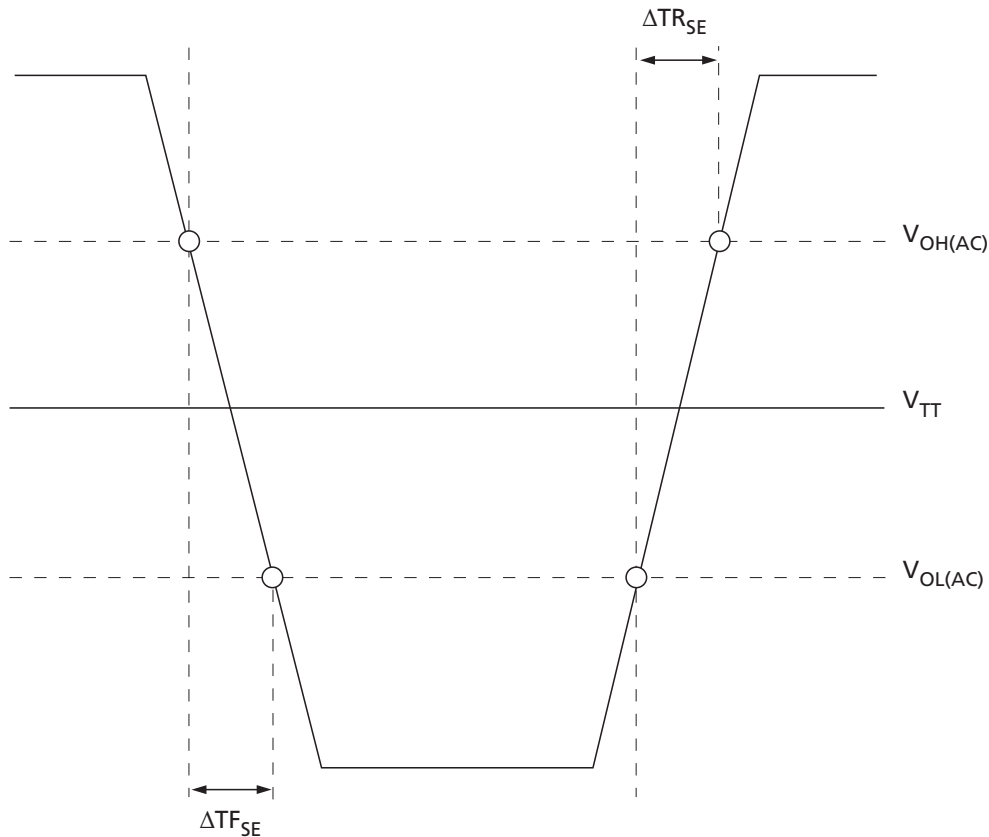

Slew Rate Definitions for Differential Output Signals

The differential output driver is summarized in the following table. With the reference load for timing measurements, the output slew rate for falling and rising edges is defined and measured between $V_{OL,diff(AC)}$ and $V_{OH,diff(AC)}$ for differential signals.

Table 26: Differential Output Slew Rate Definition

Differential Output Slew Rates (Linear Signals)		Measured		Calculation
Output	Edge	From	To	
QKx, QKx#	Rising	$V_{OL,diff(AC)}$	$V_{OH,diff(AC)}$	$\frac{V_{OH,diff(AC)max} - V_{OL,diff(AC)}}{\Delta TR_{diff}}$
	Falling	$V_{OH,diff(AC)}$	$V_{OL,diff(AC)}$	$\frac{V_{OH,diff(AC)} - V_{OL,diff(AC)}}{\Delta TF_{diff}}$

Figure 20: Nominal Differential Output Slew Rate Definition for QKx, QKx#



Speed Bin Tables

Table 27: RL3 2133/1866 Speed Bins

The MIN t_{CK} value for a given RL/WL parameter must be used to determine the t_{RC} mode register setting.

Parameter	Symbol	-093F		-093E		-107E		Units
		Min	Max	Min	Max	Min	Max	
Clock Timing								
RL = 5 ; WL = 6	t_{CK} (avg)	3	4.3	3	4.3	3.5	4.3	ns
RL = 6 ; WL = 7	t_{CK} (avg)	2.5	3.5	2.5	3.5	3	3.5	ns
RL = 7 ; WL = 8	t_{CK} (avg)	2.5	3	2.5	3	2.5	3	ns
RL = 8 ; WL = 9	t_{CK} (avg)	1.875	2.5	1.875	2.5	2	2.5	ns
RL = 9 ; WL = 10	t_{CK} (avg)	1.875	2	1.875	2	1.875	2	ns
RL = 10 ; WL = 11	t_{CK} (avg)	1.5	2	1.5	2	1.875	2	ns
RL = 11 ; WL = 12	t_{CK} (avg)	1.5	1.875	1.5	1.875	1.5	1.875	ns
RL = 12 ; WL = 13	t_{CK} (avg)	1.25	1.875	1.25	1.5	1.5	1.66	ns
RL = 13 ; WL = 14	t_{CK} (avg)	1.25	1.5	1.25	1.5	1.25	1.5	ns
RL = 14 ; WL = 15	t_{CK} (avg)	1.07	1.5	1.07	1.5	1.25	1.33	ns
RL = 15 ; WL = 16	t_{CK} (avg)	1.0	1.25	1.0	1.25	1.07	1.33	ns
RL = 16 ; WL = 17	t_{CK} (avg)	0.9375	1.25	0.9375	1.25	Reserved		ns
Row Cycle Timing								
Row cycle time	t_{RC}	7.5	–	8.0	–	8	–	ns

Table 28: RL3 1600 Speed Bins

The MIN t_{CK} value for a given RL/WL parameter must be used to determine the t_{RC} mode register setting.

Parameter	Symbol	-125F		125E		-125		Units
		Min	Max	Min	Max	Min	Max	
Clock Timing								
RL = 5 ; WL = 6	t_{CK} (avg)	Reserved		4	4.3	4	5	ns
RL = 6 ; WL = 7	t_{CK} (avg)	Reserved		3	4.3	3.5	4.3	ns
RL = 7 ; WL = 8	t_{CK} (avg)	Reserved		2.5	3	3	3.5	ns
RL = 8 ; WL = 9	t_{CK} (avg)	Reserved		2	3	2.5	3	ns
RL = 9 ; WL = 10	t_{CK} (avg)	Reserved		1.875	2	2.33	2.66	ns
RL = 10 ; WL = 11	t_{CK} (avg)	Reserved		1.875	2	2	2.33	ns
RL = 11 ; WL = 12	t_{CK} (avg)	Reserved		1.5	2	1.875	2.33	ns
RL = 12 ; WL = 13	t_{CK} (avg)	1.33	1.66	1.5	1.875	1.875	2	ns
RL = 13 ; WL = 14	t_{CK} (avg)	1.25	1.5	1.25	1.5	1.5	1.875	ns
RL = 14 ; WL = 15	t_{CK} (avg)	Reserved		1.25	1.33	1.4	1.66	ns
RL = 15 ; WL = 16	t_{CK} (avg)	Reserved		Reserved		1.33	1.66	ns
RL = 16 ; WL = 17	t_{CK} (avg)	Reserved		Reserved		1.25	1.33	ns
Row Cycle Timing								
Row cycle time	t_{RC}	8	–	10	–	12	–	ns

AC Electrical Characteristics

Table 29: AC Electrical Characteristics

Notes 1–7 apply to entire table

Parameter	Symbol	RL3–2133		RL3–1866		RL3–1600		Units	Notes	
		Min	Max	Min	Max	Min	Max			
Clock Timing										
Clock period average: DLL disable mode	$t_{CK(DLL_DIS)}$	8	488	8	488	8	488	ns	8	
Clock period average: DLL enable mode	$t_{CK(avg)}$	See t_{CK} values in the RL3 Speed Bins table.						ns	9, 10	
High pulse width average	$t_{CH(avg)}$	0.47	0.53	0.47	0.53	0.47	0.53	CK	11	
Low pulse width average	$t_{CL(avg)}$	0.47	0.53	0.47	0.53	0.47	0.53	CK	11	
Clock period jitter	DLL locked	$t_{JIT(per)}$	–50	50	–60	60	–70	70	ps	12
	DLL locking	$t_{JIT(per),lck}$	–40	40	–50	50	–60	60	ps	12
Clock absolute period	$t_{CK(abs)}$	MIN = $t_{CK(avg),min} + t_{JIT(per),min}$; MAX = $t_{CK(avg),max} + t_{JIT(per),max}$						ps		
Clock absolute high pulse width	$t_{CH(abs)}$	0.43	–	0.43	–	0.43	–	$t_{CK(avg)}$	13	
Clock absolute low pulse width	$t_{CL(abs)}$	0.43	–	0.43	–	0.43	–	$t_{CK(avg)}$	14	
Cycle-to-cycle jitter	DLL locked	$t_{JIT(cc)}$	100		120		140		ps	15
	DLL locking	$t_{JIT(cc),lck}$	80		100		120		ps	15
Cumulative error across	2 cycles	$t_{ERR(2per)}$	–74	74	–88	88	–103	103	ps	16
	3 cycles	$t_{ERR(3per)}$	–87	87	–105	105	–122	122	ps	16
	4 cycles	$t_{ERR(4per)}$	–97	97	–117	117	–136	136	ps	16
	5 cycles	$t_{ERR(5per)}$	–105	105	–126	126	–147	147	ps	16
	6 cycles	$t_{ERR(6per)}$	–111	111	–133	133	–155	155	ps	16
	7 cycles	$t_{ERR(7per)}$	–116	116	–139	139	–163	163	ps	16
	8 cycles	$t_{ERR(8per)}$	–121	121	–145	145	–169	169	ps	16
	9 cycles	$t_{ERR(9per)}$	–125	125	–150	150	–175	175	ps	16
	10 cycles	$t_{ERR(10per)}$	–128	128	–154	154	–180	180	ps	16
	11 cycles	$t_{ERR(11per)}$	–132	132	–158	158	–184	184	ps	16
	12 cycles	$t_{ERR(12per)}$	–134	134	–161	161	–188	188	ps	16
	n = 13, 14 ... 49, 50 cycles	$t_{ERR(nper)}$	$t_{ERR(nper),min} = [1 + 0.68LN(n)] \times t_{JIT(per),min}$ $t_{ERR(nper),max} = [1 + 0.68LN(n)] \times t_{JIT(per),max}$						ps	16
DQ Input Timing										
Data setup time to DK, DK#	Base (specification)	$t_{DS(AC150)}$	–30	–	–15	–	10	–	ps	17, 18
	V_{REF} @ 1 V/ns		120	–	135	–	160	–	ps	18, 19

Table 29: AC Electrical Characteristics (Continued)

Notes 1–7 apply to entire table

Parameter	Symbol	RL3–2133		RL3–1866		RL3–1600		Units	Notes	
		Min	Max	Min	Max	Min	Max			
Data setup time to DK, DK#	Base (specification)	$t_{DS}(AC120)$	60	–	75	–	100	–	ps	17, 18
	V_{REF} @ 2 V/ns		120	–	135	–	160	–	ps	18, 19
Data hold time from DK, DK#	Base (specification)	$t_{DH}(DC100)$	5	–	20	–	45	–	ps	17, 18
	V_{REF} @ 1 V/ns		105	–	120	–	145	–	ps	
Data hold time from DK, DK#	Base (specification)	$t_{DH}(DC100)$	55	–	70	–	95	–	ps	17, 18
	V_{REF} @ 2 V/ns		105	–	120	–	145	–	ps	
Minimum data pulse width	t_{DIPW}	280	–	320	–	360	–	ps	20	
DQ Output Timing										
QK, QK# edge to output data edge within byte group	t_{QKQx}	–	75	–	85	–	100	ps		
QK, QK# edge to any output data edge within specific data word grouping (only for x36)	t_{QKQ02} , t_{QKQ13}	–	125	–	135	–	150	ps	22	
DQ output hold time from QK, QK#	t_{QH}	0.38	–	0.38	–	0.38	–	$t_{CK}(avg)$	23	
DQ Low-Z time from CK, CK#	t_{LZ}	–360	180	–390	195	–450	225	ps	24, 26	
DQ High-Z time from CK, CK#	t_{HZ}	–	180	–	195	–	225	ps	24, 26	
Input and Output Strobe Timing										
DK (rising), DK# (falling) edge to/from CK (rising), CK# (falling) edge	t_{CKDK}	–0.27	0.27	–0.27	0.27	–0.27	0.27	CK	29, 34	
DK, DK# differential input HIGH width	t_{DKH}	0.45	0.55	0.45	0.55	0.45	0.55	CK		
DK, DK# differential input LOW width	t_{DKL}	0.45	0.55	0.45	0.55	0.45	0.55	CK		
QK (rising), QK# (falling) edge to CK (rising), CK# (falling) edge	t_{CKQK}	–135 – 5% t_{CK}	135 + 5% t_{CK}	–140 – 5% t_{CK}	140 + 5% t_{CK}	–160 – 5% t_{CK}	160 + 5% t_{CK}	ps	26	
QK (rising), QK# (falling) edge to CK (rising), CK# (falling) edge with DLL disabled	t_{CKQK} DLL_DIS	1	10	1	10	1	10	ns	27	
QK, QK# differential output HIGH time	t_{QKH}	0.4	–	0.4	–	0.4	–	CK	23	

Table 29: AC Electrical Characteristics (Continued)

Notes 1–7 apply to entire table

Parameter	Symbol	RL3–2133		RL3–1866		RL3–1600		Units	Notes	
		Min	Max	Min	Max	Min	Max			
QK, QK# differential output LOW time	t_{QKL}	0.4	–	0.4	–	0.4	–	CK	23	
QK (falling), QK# (rising) edge to QVLD edge	t_{QKVLD}	–	125	–	135	–	150	ps	25	
Command and Address Timing										
CTRL, CMD, ADDR, setup to CK, CK#	Base (specification)	$t_{IS}(AC150)$	85	–	120	–	170	–	ps	28, 30
	V_{REF} @ 1 V/ns		235	–	270	–	320	–	ps	19, 30
CTRL, CMD, ADDR, setup to CK, CK#	Base (specification)	$t_{IS}(AC120)$	115	–	150	–	200	–	ps	28, 30
	V_{REF} @ 1 V/ns		235	–	270	–	320	–	ps	19, 30
CTRL, CMD, ADDR, hold from CK, CK#	Base (specification)	$t_{IH}(DC100)$	65	–	100	–	120	–	ps	28, 30
	V_{REF} @ 1 V/ns		165	–	200	–	220	–	ps	19, 30
Minimum CTRL, CMD, ADDR pulse width	t_{IPW}	470	–	535	–	560	–	ps	20	
Row cycle time	t_{RC}	See minimum t_{RC} values in the RL3 Speed Bins table.						ns	21	
Refresh rate	t_{REF}	64	–	64	–	64	–	ms		
Sixteen-bank access window	t_{SAW}	8	–	8	–	8	–	ns		
Multibank access delay	t_{MMD}	2	–	2	–	2	–	CK	33	
WRITE-to-READ to same address	t_{WTR}	WL + BL/2	–	WL + BL/2	–	WL + BL/2	–	CK	32	
Mode register set cycle time to any command	t_{MRSC}	12	–	12	–	12	–	CK		
READ training register minimum READ time	t_{RTRS}	2	–	2	–	2	–	CK		
READ training register burst end to mode register set for training register exit	t_{RTRE}	1	–	1	–	1	–	CK		
Calibration Timing										
	POWER-UP and RE-SET operation	t_{ZQinit}	512	–	512	–	512	–	CK	
	Normal operation	t_{ZQoper}	256	–	256	–	256	–	CK	
ZQCS: Short calibration time	t_{ZQcs}	64	–	64	–	64	–	CK		
Initialization and Reset Timing										
Begin power-supply ramp to power supplies stable	$t_{V_{DDPR}}$	–	200	–	200	–	200	ms		

Table 29: AC Electrical Characteristics (Continued)

Notes 1–7 apply to entire table

Parameter	Symbol	RL3–2133		RL3–1866		RL3–1600		Units	Notes
		Min	Max	Min	Max	Min	Max		
RESET# LOW to power supplies stable	t_{RPS}	–	200	–	200	–	200	ms	
RESET# LOW to I/O and R _{TT} High-Z	t_{IOZ}	–	20	–	20	–	20	ns	31

- Notes:
- Parameters are applicable with $0^{\circ}\text{C} \leq T_C \leq +95^{\circ}\text{C}$; $+1.28\text{V} \leq V_{DD} \leq +1.42\text{V}$, $+2.38\text{V} \leq V_{EXT} \leq +2.63\text{V}$, $+1.14\text{V} \leq V_{DDQ} \leq 1.26\text{V}$.
 - All voltages are referenced to V_{SS} .
 - The unit $t_{CK(ave)}$ represents the actual $t_{CK(ave)}$ of the input clock under operation. The unit CK represents one clock cycle of the input clock, counting the actual clock edges.
 - AC timing and I_{DD} tests may use a V_{IL} -to- V_{IH} swing of up to 900mV in the test environment, but input timing is still referenced to V_{REF} (except t_{IS} , t_{IH} , t_{DS} , and t_{DH} use the AC/DC trip points and CK,CK# and DKx, DKx# use their crossing points). The minimum slew rate for the input signals used to test the device is 1 V/ns for single-ended inputs and 2 V/ns for differential inputs in the range between $V_{IL(AC)}$ and $V_{IH(AC)}$.
 - All timings that use time-based values (ns, μs , ms) should use $t_{CK(ave)}$ to determine the correct number of clocks. In the case of noninteger results, all minimum limits should be rounded up to the nearest whole integer, and all maximum limits should be rounded down to the nearest whole integer.
 - The term "strobe" refers to the DK and DK# or QK and QK# differential crossing point when DK and QK, respectively, is the rising edge. Clock, or CK, refers to the CK and CK# differential crossing point when CK is the rising edge.
 - The output load defined in Figure 18 (page 42) is used for all AC timing and slew rates. The actual test load may be different. The output signal voltage reference point is $V_{DDQ}/2$ for single-ended signals and the crossing point for differential signals.
 - When operating in DLL disable mode, Micron does not warrant compliance with normal mode timings or functionality.
 - The clock's $t_{CK(ave)}$ is the average clock over any 200 consecutive clocks and $t_{CK(ave),min}$ is the smallest clock rate allowed, with the exception of a deviation due to clock jitter. Input clock jitter is allowed provided it does not exceed values specified and must be of a random Gaussian distribution in nature.
 - Spread spectrum is not included in the jitter specification values. However, the input clock can accommodate spread spectrum at a sweep rate in the range of 20–60 kHz with an additional 1% of $t_{CK(ave)}$ as a long-term jitter component; however, the spread spectrum may not use a clock rate below $t_{CK(ave),min}$.
 - The clock's $t_{CH(ave)}$ and $t_{CL(ave)}$ are the average half-clock period over any 200 consecutive clocks and is the smallest clock half-period allowed, with the exception of a deviation due to clock jitter. Input clock jitter is allowed provided it does not exceed values specified and must be of a random Gaussian distribution in nature.
 - The period jitter, $t_{JIT(per)}$, is the maximum deviation in the clock period from the average or nominal clock. It is allowed in either the positive or negative direction.
 - $t_{CH(abs)}$ is the absolute instantaneous clock high pulse width as measured from one rising edge to the following falling edge.
 - $t_{CL(abs)}$ is the absolute instantaneous clock low pulse width as measured from one falling edge to the following rising edge.

15. The cycle-to-cycle jitter, $t_{JIT(cc)}$, is the amount the clock period can deviate from one cycle to the next. It is important to keep cycle-to-cycle jitter at a minimum during the DLL locking time.
16. The cumulative jitter error, $t_{ERR(nper)}$, where n is the number of clocks between 2 and 50, is the amount of clock time allowed to accumulate consecutively away from the average clock over n number of clock cycles.
17. $t_{DS(base)}$ and $t_{DH(base)}$ values are for a single-ended 1 V/ns DQ slew rate and 2 V/ns differential DK, DK# slew rate.
18. These parameters are measured from a data signal (DM, DQ0, DQ1, and so forth) transition edge to its respective data strobe signal (DK, DK#) crossing.
19. The setup and hold times are listed converting the base specification values (to which derating tables apply) to V_{REF} when the slew rate is 1 V/ns. These values, with a slew rate of 1 V/ns, are for reference only.
20. Pulse width of an input signal is defined as the width between the first crossing of $V_{REF(DC)}$ and the consecutive crossing of $V_{REF(DC)}$.
21. Mode Register 0 (MR0), bits [3:0] selects the number of clock cycles required to satisfy the minimum t_{RC} value. The value programmed into these bits must match one of the allowed combinations shown in the t_{RC_MRS} table.
22. t_{QKQ02} defines the skew between QK0 and DQ[26:18] and between QK2 and DQ[8:0]. t_{QKQ13} defines the skew between QK1 and DQ[35:27] and between QK3 and DQ[17:9].
23. When the device is operated with input clock jitter, this parameter needs to be derated by the actual $t_{JIT(per)}$ (the larger of $t_{JIT(per),min}$ or $t_{JIT(per),max}$ of the input clock; output deratings are relative to the SDRAM input clock).
24. Single-ended signal parameter.
25. For x36 device this specification references the skew between the falling edge of QK0 and QK1 to QVLD0 and the falling edge of QK2 and QK3 to QVLD1.
26. The DRAM output timing is aligned to the nominal or average clock. The following output parameters must be derated by the actual jitter error when input clock jitter is present, even when within specification. This results in each parameter becoming larger. The following parameters are required to be derated by subtracting $t_{ERR(10per),max}$: $t_{CKQK (MIN)}$, and $t_{LZ (MIN)}$. The following parameters are required to be derated by subtracting $t_{ERR(10per),min}$: $t_{CKQK (MAX)}$, $t_{HZ (MAX)}$, and $t_{LZ (MAX)}$.
27. The $t_{DQSKdll_dis}$ parameter begins RL - 1 cycles after the READ command.
28. $t_{IS(base)}$ and $t_{IH(base)}$ values are for a single-ended 1 V/ns control/command/address slew rate and 2 V/ns CK, CK# differential slew rate.
29. These parameters are measured from the input data strobe signal (DK/DK#) crossing to its respective clock signal crossing (CK/CK#). The specification values are not affected by the amount of clock jitter applied as they are relative to the clock signal crossing. These parameters should be met whether or not clock jitter is present.
30. These parameters are measured from a command/address signal transition edge to its respective clock (CK, CK#) signal crossing. The specification values are not affected by the amount of clock jitter applied as the setup and hold times are relative to the clock signal crossing that latches the command/address. These parameters should be met whether or not clock jitter is present.
31. RESET# should be LOW as soon as power starts to ramp to ensure the outputs are in High-Z. Until RESET# is LOW, the outputs are at risk of driving and could result in excessive current, depending on bus activity.
32. If t_{WTR} is violated, the data just written will not be read out when a READ command is issued to the same address. Whatever data was previously written to the address will be output with the READ command.
33. This specification is defined as any bank command (READ, WRITE, AREF) to a multi-bank command or a multi-bank command to any bank command. This specification only applies to quad bank WRITE, 3-bank AREF and 4-bank AREF commands. Dual bank WRITE, 2-bank AREF, and all single bank access commands are not bound by this specification.

34. If the alignment of CK to DK exceeds the data sheet t_{CKDK} specification for the purposes of system calibration or timing adjustments, it is possible to put the device into an undefined state, which will cause write failures. The device will remain in this state until either an MR0 command or a RESET# is issued.

Temperature and Thermal Impedance Characteristics

It is imperative that the device's temperature specifications be maintained in order to ensure that the junction temperature is in the proper operating range to meet data sheet specifications. An important way to maintain the proper junction temperature is to use the device's thermal impedances correctly. Thermal impedances are listed for the available packages.

Incorrectly using thermal impedances can produce significant errors. Read Micron technical note TN-00-08, "Thermal Applications" prior to using thermal impedances listed below.

The device's safe junction temperature range can be maintained when the T_C specification is not exceeded. In applications where the device's ambient temperature is too high, use of forced air and/or heat sinks may be required in order to meet the case temperature specifications.

Table 30: Temperature Limits

Parameter		Symbol	Min	Max	Units	Notes
Storage temperature		T_{STG}	-55	150	°C	1
Reliability junction temperature	Commercial	$T_{J(REL)}$	-	110	°C	2
	Industrial		-	110	°C	2
Operating junction temperature	Commercial	$T_{J(OP)}$	0	100	°C	3
	Industrial		-40	100	°C	3
Operating case temperature	Commercial	T_C	0	95	°C	4, 5
	Industrial		-40	95	°C	4, 5

- Notes:
1. MAX storage case temperature; T_{STG} is measured in the center of the package (see Figure 21 (page 54)). This case temperature limit is allowed to be exceeded briefly during package reflow, as noted in Micron technical note TN-00-15.
 2. Temperatures greater than 110°C may cause permanent damage to the device. This is a stress rating only and functional operation of the device at or above this is not implied. Exposure to absolute maximum rating conditions for extended periods may adversely affect the reliability of the part.
 3. Junction temperature depends upon package type, cycle time, loading, ambient temperature, and airflow.
 4. MAX operating case temperature; T_C is measured in the center of the package (see Figure 21 (page 54)).
 5. Device functionality is not guaranteed if the device exceeds maximum T_C during operation.

Table 31: Thermal Impedance

Package	Substrate	θ_{JA} (°C/W) Airflow = 0m/s	θ_{JA} (°C/W) Airflow = 1m/s	θ_{JA} (°C/W) Airflow = 2m/s	θ_{JB} (°C/W)	θ_{JC} (°C/W)
Die Rev A	Low conductivity	39.3	28.8	25.2	N/A	2.0
	High conductivity	22.0	17.2	15.9	10.3	N/A

Table 31: Thermal Impedance (Continued)

Package	Substrate	θ_{JA} ($^{\circ}\text{C}/\text{W}$) Airflow = 0m/s	θ_{JA} ($^{\circ}\text{C}/\text{W}$) Airflow = 1m/s	θ_{JA} ($^{\circ}\text{C}/\text{W}$) Airflow = 2m/s	θ_{JB} ($^{\circ}\text{C}/\text{W}$)	θ_{JC} ($^{\circ}\text{C}/\text{W}$)
Die Rev B	Low conductivity	38.7	28.7	25.5	N/A	2.1
	High conductivity	21.8	17.2	16.0	6.4	N/A

Note: 1. Thermal impedance data is based on a number of samples from multiple lots, and should be viewed as a typical number.

Figure 21: Example Temperature Test Point Location

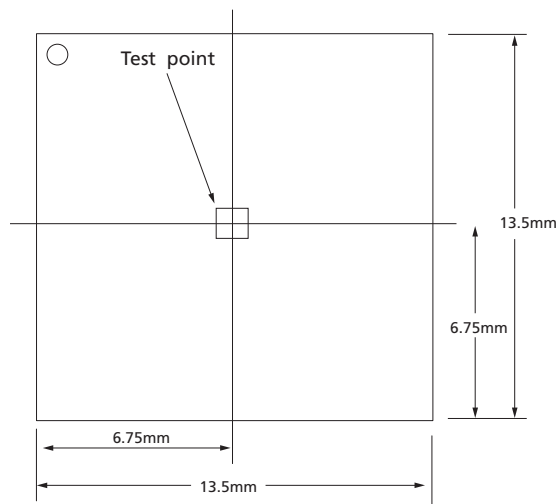

Command and Address Setup, Hold, and Derating

The total t_{IS} (setup time) and t_{IH} (hold time) required is calculated by adding the data sheet t_{IS} (base) and t_{IH} (base) values (see Table 32 (page 55); values come from (page 0)) to the Δt_{IS} and Δt_{IH} derating values (see Table 33 (page 56)), respectively. Example: t_{IS} (total setup time) = t_{IS} (base) + Δt_{IS} . For a valid transition, the input signal must remain above/below $V_{IH(AC)}/V_{IL(AC)}$ for some time t_{VAC} (see Table 35 (page 57)).

Although the total setup time for slow slew rates might be negative (for example, a valid input signal will not have reached $V_{IH(AC)}/V_{IL(AC)}$ at the time of the rising clock transition), a valid input signal is still required to complete the transition and to reach $V_{IH(AC)}/V_{IL(AC)}$. For slew rates which fall between the values listed in Table 33 (page 56) and Table 35 (page 57) for Valid Transition, the derating values may be obtained by linear interpolation.

Setup (t_{IS}) nominal slew rate for a rising signal is defined as the slew rate between the last crossing of $V_{REF(DC)}$ and the first crossing of $V_{IH(AC)min}$. Setup (t_{IS}) nominal slew rate for a falling signal is defined as the slew rate between the last crossing of $V_{REF(DC)}$ and the first crossing of $V_{IL(AC)max}$. If the actual signal is always earlier than the nominal slew rate line between the shaded $V_{REF(DC)}$ -to-AC region, use the nominal slew rate for derating value (see Figure 22 (page 58)). If the actual signal is later than the nominal slew rate line anywhere between the shaded $V_{REF(DC)}$ -to-AC region, the slew rate of a tangent line to the actual signal from the AC level to the DC level is used for derating value (see Figure 24 (page 60)).

Hold (t_{IH}) nominal slew rate for a rising signal is defined as the slew rate between the last crossing of $V_{IL(DC)max}$ and the first crossing of $V_{REF(DC)}$. Hold (t_{IH}) nominal slew rate for a falling signal is defined as the slew rate between the last crossing of $V_{IH(DC)min}$ and the first crossing of $V_{REF(DC)}$. If the actual signal is always later than the nominal slew rate line between the shaded DC-to- $V_{REF(DC)}$ region, use the nominal slew rate for derating value (see Figure 23 (page 59)). If the actual signal is earlier than the nominal slew rate line anywhere between the shaded DC-to- $V_{REF(DC)}$ region, the slew rate of a tangent line to the actual signal from the DC level to the $V_{REF(DC)}$ level is used for derating value (see Figure 25 (page 61)).

Table 32: Command and Address Setup and Hold Values Referenced at 1 V/ns – AC/DC-Based

Symbol	RL3-2133	RL3-1866	RL3-1600	Units	Reference
$t_{IS}(base),AC150$	85	120	170	ps	$V_{IH(AC)}/V_{IL(AC)}$
$t_{IS}(base),AC120$	115	150	200	ps	$V_{IH(AC)}/V_{IL(AC)}$
$t_{IH}(base),DC100$	65	100	120	ps	$V_{IH(DC)}/V_{IL(DC)}$



Table 33: Derating Values for t_{IS}/t_{IH} – AC150/DC100-Based

$\Delta t_{IS}, \Delta t_{IH}$ Derating (ps) - AC/DC-Based AC 150 Threshold: $V_{IH(AC)} = V_{REF(DC)} + 150mV, V_{IL(AC)} = V_{REF(DC)} - 150mV$																
CMD/ADDR Slew Rate (V/ns)	CK, CK# Differential Slew Rate															
	4.0 V/ns		3.0 V/ns		2.0 V/ns		1.8 V/ns		1.6 V/ns		1.4 V/ns		1.2 V/ns		1.0 V/ns	
	Δt_{IS}	Δt_{IH}	Δt_{IS}	Δt_{IH}	Δt_{IS}	Δt_{IH}	Δt_{IS}	Δt_{IH}	Δt_{IS}	Δt_{IH}	Δt_{IS}	Δt_{IH}	Δt_{IS}	Δt_{IH}	Δt_{IS}	Δt_{IH}
2.0	75	50	75	50	75	50	83	58	91	66	99	74	107	84	115	100
1.5	50	34	50	34	50	34	58	42	66	50	74	58	82	68	90	84
1.0	0	0	0	0	0	0	8	8	16	16	24	24	32	34	40	50
0.9	0	-4	0	-4	0	-4	8	4	16	12	24	20	32	30	40	46
0.8	0	-10	0	-10	0	-10	8	-2	16	6	24	14	32	24	40	40
0.7	0	-16	0	-16	0	-16	8	-8	16	0	24	8	32	18	40	34
0.6	-1	-26	-1	-26	-1	-26	7	-18	15	-10	23	-2	31	8	39	24
0.5	-10	-40	-10	-40	-10	-40	-2	-32	6	-24	14	-16	22	-6	30	10
0.4	-25	-60	-25	-60	-25	-60	-17	-52	-9	-44	-1	-36	7	-26	15	-10

Table 34: Derating Values for t_{IS}/t_{IH} – AC120/DC100-Based

$\Delta t_{IS}, \Delta t_{IH}$ Derating (ps) - AC/DC-Based AC 120 Threshold: $V_{IH(AC)} = V_{REF(DC)} + 120mV, V_{IL(AC)} = V_{REF(DC)} - 120mV$																
CMD/ADDR Slew Rate (V/ns)	CK, CK# Differential Slew Rate															
	4.0 V/ns		3.0 V/ns		2.0 V/ns		1.8 V/ns		1.6 V/ns		1.4 V/ns		1.2 V/ns		1.0 V/ns	
	Δt_{IS}	Δt_{IH}	Δt_{IS}	Δt_{IH}	Δt_{IS}	Δt_{IH}	Δt_{IS}	Δt_{IH}	Δt_{IS}	Δt_{IH}	Δt_{IS}	Δt_{IH}	Δt_{IS}	Δt_{IH}	Δt_{IS}	Δt_{IH}
2.0	60	50	60	50	60	50	68	58	76	66	84	74	92	84	100	100
1.5	40	34	40	34	40	34	48	42	56	50	64	58	72	68	80	84
1.0	0	0	0	0	0	0	8	8	16	16	24	24	32	34	40	50
0.9	0	-4	0	-4	0	-4	8	4	16	12	24	20	32	30	40	46
0.8	0	-10	0	-10	0	-10	8	-2	16	6	24	14	32	24	40	40
0.7	0	-16	0	-16	0	-16	8	-8	16	0	24	8	32	18	40	34
0.6	-1	-26	-1	-26	-1	-26	7	-18	15	-10	23	-2	31	8	39	24
0.5	-10	-40	-10	-40	-10	-40	-2	-32	6	-24	14	-16	22	-6	30	10
0.4	-25	-60	-25	-60	-25	-60	-17	-52	-9	-44	-1	-36	7	-26	15	-10

Table 35: Minimum Required Time t_{VAC} Above $V_{IH(AC)}$ (or Below $V_{IL(AC)}$) for Valid Transition

Slew Rate (V/ns)	t_{VAC} (ps)
>2.0	175
2.0	170
1.5	167
1.0	163
0.9	162
0.8	161
0.7	159
0.6	155
0.5	150
<0.5	150

Figure 22: Nominal Slew Rate and t_{VAC} for t_{IS} (Command and Address - Clock)



$$\text{Setup slew rate falling signal} = \frac{V_{REF(DC)} - V_{IL(AC)max}}{\Delta TF}$$

$$\text{Setup slew rate rising signal} = \frac{V_{IH(AC)min} - V_{REF(DC)}}{\Delta TR}$$

Note: 1. Both the clock and the data strobe are drawn on different time scales.

Figure 23: Nominal Slew Rate for t_{IH} (Command and Address - Clock)

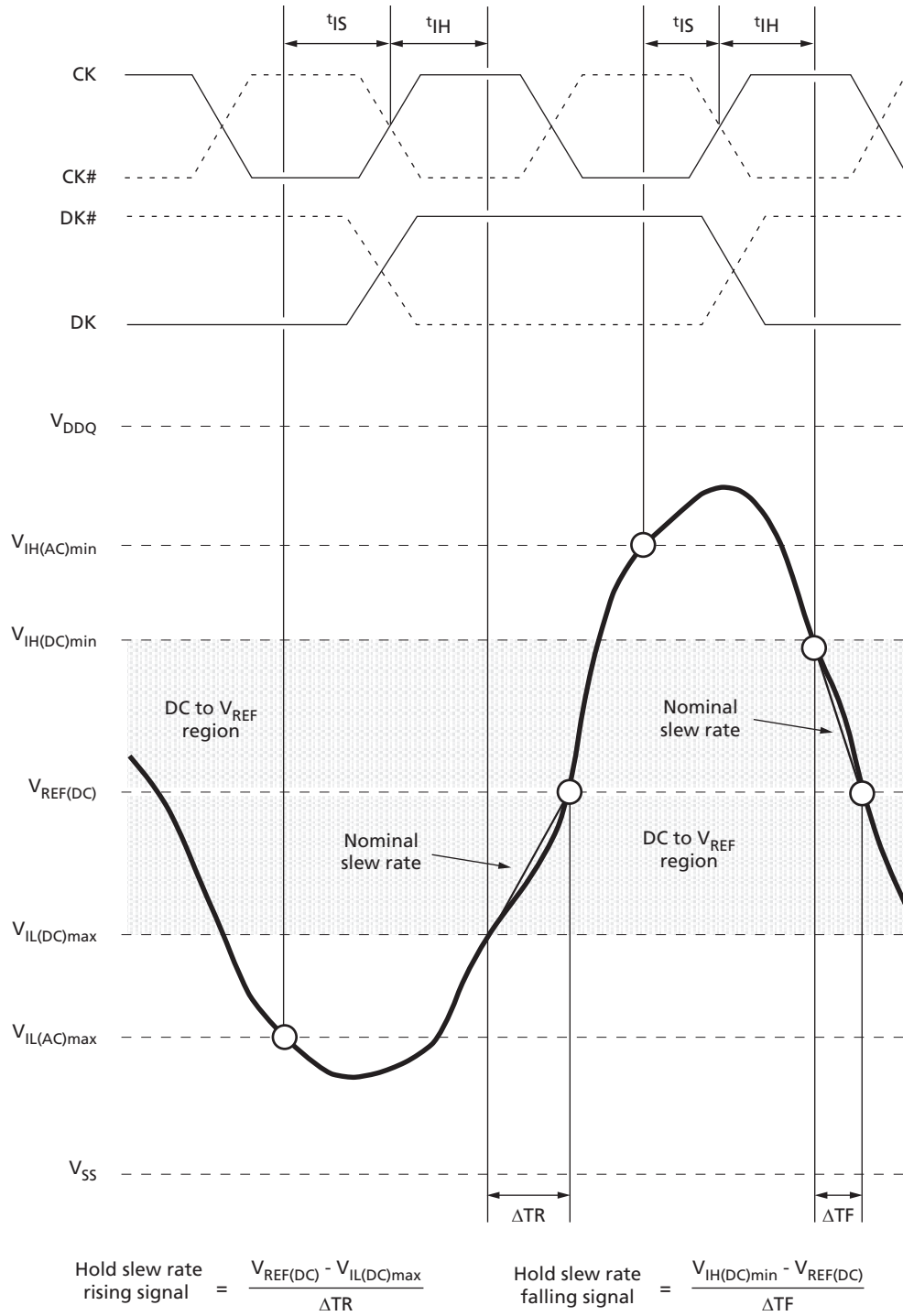

Note: 1. Both the clock and the data strobe are drawn on different time scales.

Figure 24: Tangent Line for t_{IS} (Command and Address - Clock)



Note: 1. Both the clock and the data strobe are drawn on different time scales.

Figure 25: Tangent Line for t_{IH} (Command and Address - Clock)



Note: 1. Both the clock and the data strobe are drawn on different time scales.

Data Setup, Hold, and Derating

The total t_{DS} (setup time) and t_{DH} (hold time) required is calculated by adding the data sheet t_{DS} (base) and t_{DH} (base) values (see the table below; values come from (page 0)) to the Δt_{DS} and Δt_{DH} derating values (see Table 37 (page 63)), respectively. Example: t_{DS} (total setup time) = t_{DS} (base) + Δt_{DS} . For a valid transition, the input signal has to remain above/below $V_{IH(AC)}/V_{IL(AC)}$ for some time t_{VAC} (see Table 39 (page 64)).

Although the total setup time for slow slew rates might be negative (for example, a valid input signal will not have reached $V_{IH(AC)}/V_{IL(AC)}$ at the time of the rising clock transition), a valid input signal is still required to complete the transition and to reach $V_{IH}/V_{IL(AC)}$. For slew rates which fall between the values listed in Table 37 (page 63) and Table 39 (page 64), the derating values may be obtained by linear interpolation.

Setup (t_{DS}) nominal slew rate for a rising signal is defined as the slew rate between the last crossing of $V_{REF(DC)}$ and the first crossing of $V_{IH(AC)min}$. Setup (t_{DS}) nominal slew rate for a falling signal is defined as the slew rate between the last crossing of $V_{REF(DC)}$ and the first crossing of $V_{IL(AC)max}$. If the actual signal is always earlier than the nominal slew rate line between the shaded $V_{REF(DC)}$ -to-AC region, use the nominal slew rate for derating value (see Figure 26 (page 65)). If the actual signal is later than the nominal slew rate line anywhere between the shaded $V_{REF(DC)}$ -to-AC region, the slew rate of a tangent line to the actual signal from the AC level to the DC level is used for derating value (see Figure 28 (page 67)).

Hold (t_{DH}) nominal slew rate for a rising signal is defined as the slew rate between the last crossing of $V_{IL(DC)max}$ and the first crossing of $V_{REF(DC)}$. Hold (t_{DH}) nominal slew rate for a falling signal is defined as the slew rate between the last crossing of $V_{IH(DC)min}$ and the first crossing of $V_{REF(DC)}$. If the actual signal is always later than the nominal slew rate line between the shaded DC-to- $V_{REF(DC)}$ region, use the nominal slew rate for derating value (see Figure 27 (page 66)). If the actual signal is earlier than the nominal slew rate line anywhere between the shaded DC-to- $V_{REF(DC)}$ region, the slew rate of a tangent line to the actual signal from the DC-to- $V_{REF(DC)}$ region is used for derating value (see Figure 29 (page 68)).

Table 36: Data Setup and Hold Values at 1 V/ns (DKx, DKx# at 2V/ns) – AC/DC-Based

Symbol	RL3-2133	RL3-1866	RL3-1600	Units	Reference
$t_{DS}(\text{base}), AC150$ at 1V/ns	-30	-15	10	ps	$V_{IH(AC)}/V_{IL(AC)}$
$t_{DS}(\text{base}), AC120$ at 2v/ns	60	75	100	ps	$V_{IH(AC)}/V_{IL(AC)}$
$t_{DH}(\text{base}), DC100$ at 1v/ns	5	20	45	ps	$V_{IH(DC)}/V_{IL(DC)}$
$t_{DH}(\text{base}), DC100$ at 2v/ns	55	70	95	ps	$V_{IH(DC)}/V_{IL(DC)}$



Table 37: Derating Values for t_{DS}/t_{DH} – AC150/DC100-Based

Empty cells indicate slew rate combinations not supported

$\Delta t_{DS}, \Delta t_{DH}$ Derating (ps) - AC/DC-Based																
DQ Slew Rate (V/ns)	DKx, DKx# Differential Slew Rate															
	4.0 V/ns		3.0 V/ns		2.0 V/ns		1.8 V/ns		1.6 V/ns		1.4 V/ns		1.2 V/ns		1.0 V/ns	
	Δt_{DS}	Δt_{DH}	Δt_{DS}	Δt_{DH}	Δt_{DS}	Δt_{DH}	Δt_{DS}	Δt_{DH}	Δt_{DS}	Δt_{DH}	Δt_{DS}	Δt_{DH}	Δt_{DS}	Δt_{DH}	Δt_{DS}	Δt_{DH}
2.0	75	50	75	50	75	50										
1.5	50	34	50	34	50	34	58	42								
1.0	0	0	0	0	0	0	8	8	16	16						
0.9			0	-4	0	-4	8	4	16	12	24	20				
0.8					0	-10	8	-2	16	6	24	14	32	24		
0.7							8	-8	16	0	24	8	32	18	40	34
0.6									15	-10	23	-2	31	8	39	24
0.5											14	-16	22	-6	30	10
0.4													7	-26	15	-10

Table 38: Derating Values for t_{DS}/t_{DH} – AC120/DC100-Based

Empty cells indicate slew rate combinations not supported

$\Delta t_{DS}, \Delta t_{DH}$ Derating (ps) - AC/DC-Based																
DQ Slew Rate (V/ns)	DKx, DKx# Differential Slew Rate															
	8.0 V/ns		7.0 V/ns		6.0 V/ns		5.0 V/ns		4.0 V/ns		3.0 V/ns		2.0 V/ns		1.8 V/ns	
	Δt_{DS}	Δt_{DH}	Δt_{DS}	Δt_{DH}	Δt_{DS}	Δt_{DH}	Δt_{DS}	Δt_{DH}	Δt_{DS}	Δt_{DH}	Δt_{DS}	Δt_{DH}	Δt_{DS}	Δt_{DH}	Δt_{DS}	Δt_{DH}
4.0	30	25	30	25	30	25										
3.5	26	22	26	22	26	22	26	22								
3.0	20	17	20	17	20	17	20	17	20	17						
2.5			12	10	12	10	12	10	12	10	12	10				
2.0					0	0	0	0	0	0	0	0	0	0		
1.5							-20	-16	-20	-16	-20	-16	-20	-16	-12	-8
1.0									-60	-50	-60	-50	-60	-50	-52	-42
0.9											-60	-50	-60	-50	-52	-42
0.8													-60	-50	-52	-42

Table 39: Minimum Required Time t_{VAC} Above $V_{IH(AC)}$ (or Below $V_{IL(AC)}$) for Valid Transition

Slew Rate (V/ns)	t_{VAC} (ps)
>2.0	175
2.0	170
1.5	167
1.0	163
0.9	162
0.8	161
0.7	159
0.6	155
0.5	150
<0.5	150

Figure 26: Nominal Slew Rate and t_{VAC} for t_{DS} (DQ - Strobe)

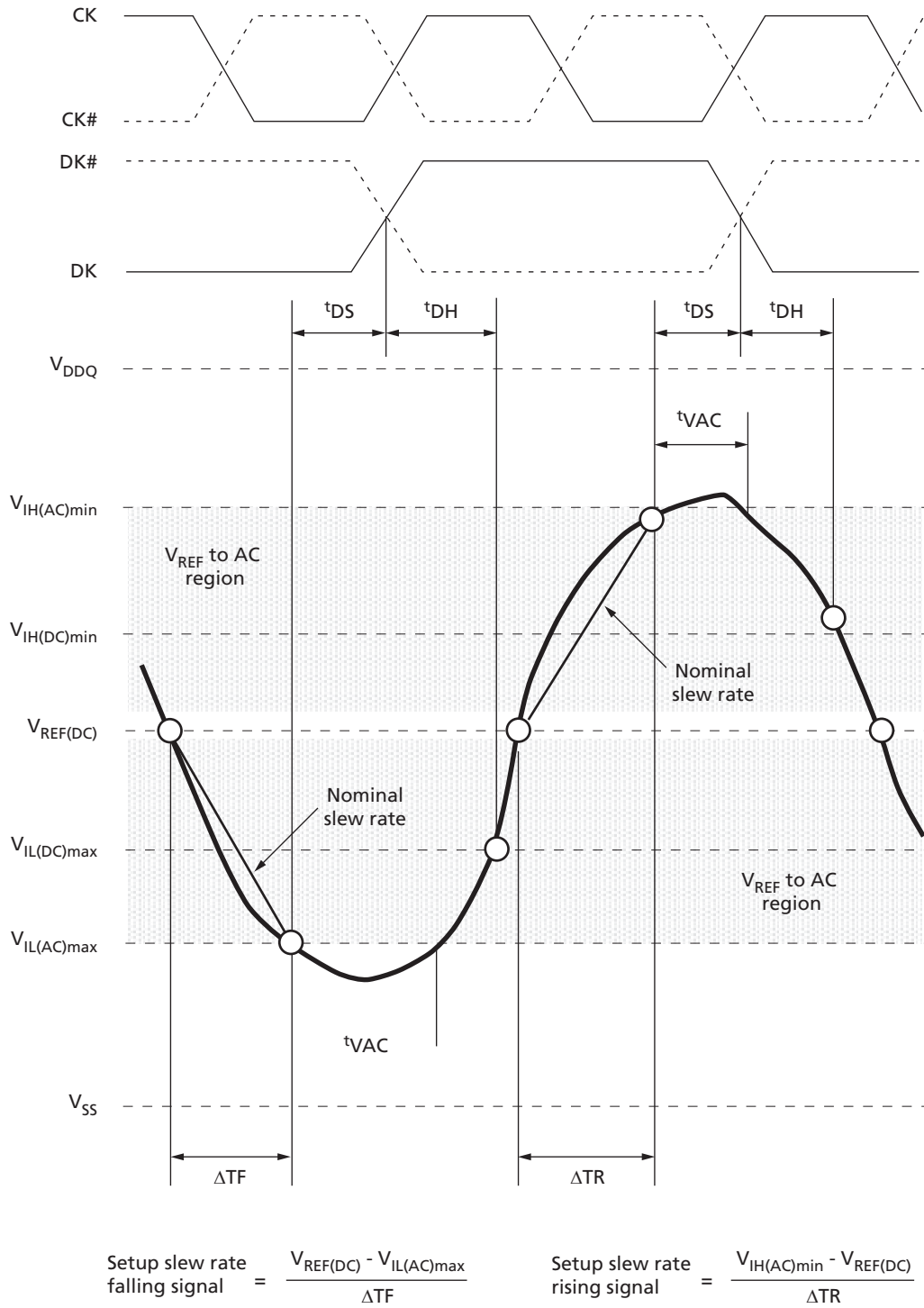

Note: 1. Both the clock and the strobe are drawn on different time scales.

Figure 27: Nominal Slew Rate for t_{DH} (DQ - Strobe)



$$\text{Hold slew rate rising signal} = \frac{V_{REF(DC)} - V_{IL(DC)max}}{\Delta TR}$$

$$\text{Hold slew rate falling signal} = \frac{V_{IH(DC)min} - V_{REF(DC)}}{\Delta TF}$$

Note: 1. Both the clock and the strobe are drawn on different time scales.

Figure 28: Tangent Line for t_{DS} (DQ - Strobe)

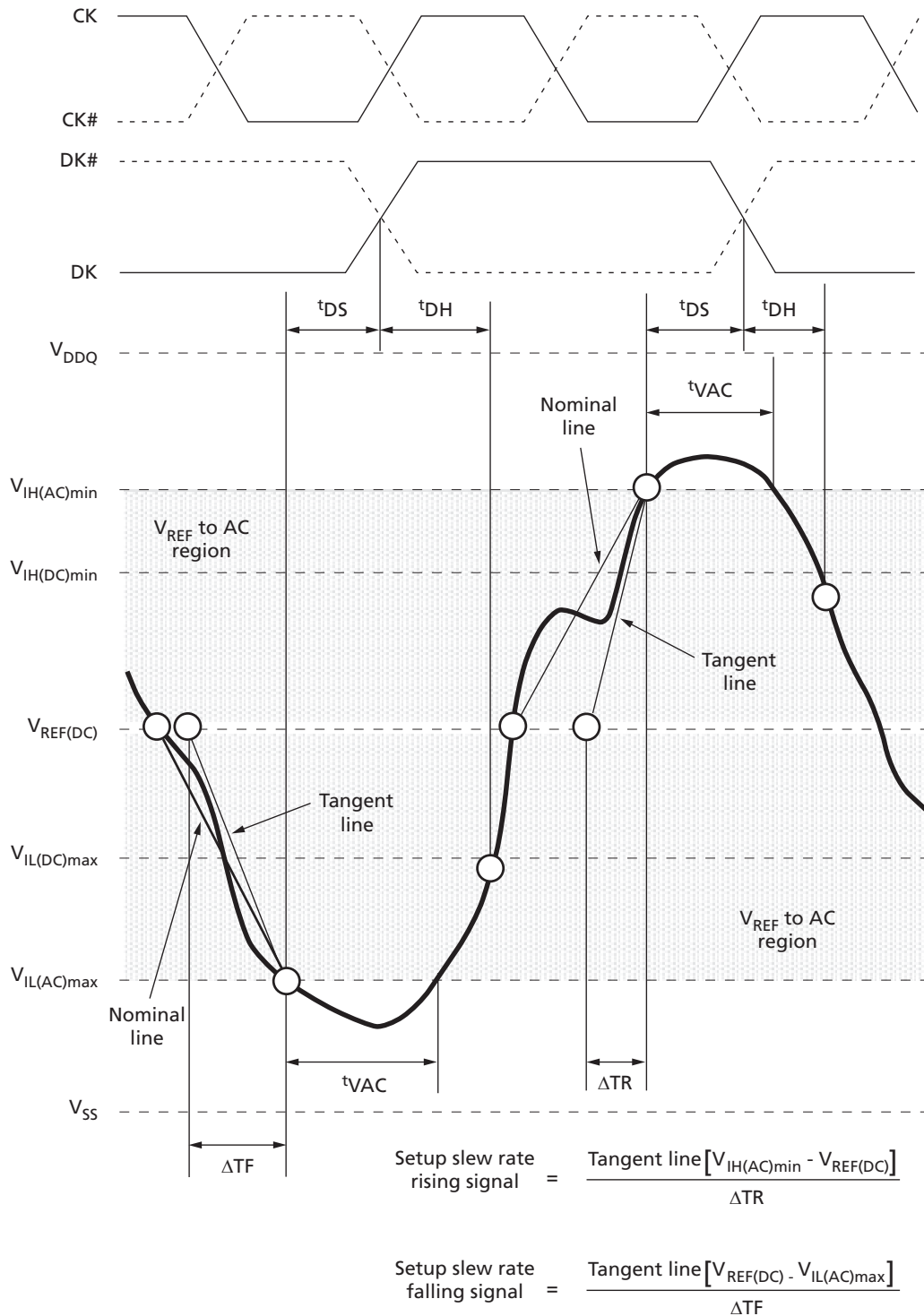

Note: 1. Both the clock and the strobe are drawn on different time scales.

Figure 29: Tangent Line for t_{DH} (DQ - Strobe)



$$\text{Hold slew rate rising signal} = \frac{\text{Tangent line} [V_{REF(DC)} - V_{IL(DC)max}]}{\Delta TR}$$

$$\text{Hold slew rate falling signal} = \frac{\text{Tangent line} [V_{IH(DC)min} - V_{REF(DC)}]}{\Delta TF}$$

Note: 1. Both the clock and the strobe are drawn on different time scales.

Commands

The following table provides descriptions of the valid commands of the RLD RAM 3 device. All command and address inputs must meet setup and hold times with respect to the rising edge of CK.

Table 40: Command Descriptions

Command	Description
NOP	The NOP command prevents new commands from being executed by the DRAM. Operations already in progress are not affected by NOP commands. Output values depend on command history.
MRS	Mode registers MR0, MR1, and MR2 are used to define various modes of programmable operations of the DRAM. A mode register is programmed via the MODE REGISTER SET (MRS) command during initialization and retains the stored information until it is reprogrammed, RESET# goes LOW, or until the device loses power. The MRS command can be issued only when all banks are idle, and no bursts are in progress.
READ	The READ command is used to initiate a burst read access to a bank. The BA[3:0] inputs select a bank, and the address provided on inputs A[19:0] select a specific location within a bank.
WRITE	The WRITE command is used to initiate a burst write access to a bank (or banks). MRS bits MR2[4:3] select single, dual, or quad bank WRITE protocol. The BA[x:0] inputs select the bank(s) (x = 3, 2, or 1 for single, dual, or quad bank WRITE, respectively). The address provided on inputs A[19:0] select a specific location within the bank. Input data appearing on the DQ is written to the memory array subject to the DM input logic level appearing coincident with the data. If the DM signal is registered LOW, the corresponding data will be written to memory. If the DM signal is registered HIGH, the corresponding data inputs will be ignored (that is, this part of the data word will not be written).
AREF	The AREF command is used during normal operation of the RLD RAM 3 to refresh the memory content of a bank. There are two methods by which the RLD RAM 3 can be refreshed, both of which are selected within the mode register. The first method, bank address-controlled AREF, is identical to the method used in RLD RAM 2. The second method, multibank AREF, enables refreshing of up to four banks simultaneously. More information is available in the Auto Refresh section. For both methods, the command is nonpersistent, so it must be issued each time a refresh is required.

Table 41: Command Table

Note 1 applies to the entire table

Operation	Code	CS#	WE#	REF#	A[19:0]	BA[3:0]	Notes
NOP	NOP	H	X	X	X	X	
MRS	MRS	L	L	L	OPCODE	OPCODE	
READ	READ	L	H	H	A	BA	2
WRITE	WRITE	L	L	H	A	BA	2
AUTO REFRESH	AREF	L	H	L	A	BA	3

- Notes:
1. X = "Don't Care;" H = logic HIGH; L = logic LOW; A = valid address; BA = valid bank address; OPCODE = mode register bits
 2. Address width varies with burst length and configuration; see the Address Widths of Different Burst Lengths table for more information.
 3. Bank address signals (BA) are used only during bank address-controlled AREF; Address signals (A) are used only during multibank AREF.

MODE REGISTER SET (MRS) Command

The mode registers, MR0, MR1, and MR2, store the data for controlling the operating modes of the memory. The MODE REGISTER SET (MRS) command programs the RLD RAM 3 operating modes and I/O options. During an MRS command, the address inputs are sampled and stored in the mode registers. The BA[1:0] signals select between mode registers 0–2 (MR0–MR2). After the MRS command is issued, each mode register retains the stored information until it is reprogrammed, until RESET# goes LOW, or until the device loses power.

After issuing a valid MRS command, ^tMRSC must be met before any command can be issued to the RLD RAM 3. The MRS command can be issued only when all banks are idle, and no bursts are in progress.

Figure 30: MRS Command Protocol

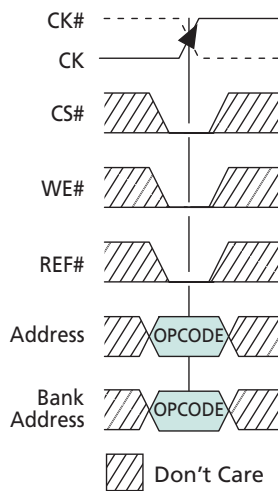

Mode Register 0 (MR0)

Figure 31: MR0 Definition for Non-Multiplexed Address Mode



- Notes:
1. BA2, BA3, and all address balls corresponding to reserved bits must be held LOW during the MRS command.
 2. BL8 not allowed.

t_{RC}

Bits MR0[3:0] select the number of clock cycles required to satisfy the t_{RC} specifications.

After a READ, WRITE, or AREF command is issued to a bank, a subsequent READ, WRITE, or AREF cannot be issued to the same bank until t_{RC} has been satisfied.

The correct (t_{RC_MRS}) value to program for MR0 command bits [3:0] is shown in the table below. These are the only allowed settings. Using a value other than the one shown for a given RL/WL and speed grade combination is not allowed.

Table 42: t_{RC_MRS} Values

Parameter	-093F	-093E	-107E	-125F	-125E	-125
RL = 5; WL = 6	3	3	3	Reserved	3	3
RL = 6; WL = 7	3	4	3	Reserved	4	4
RL = 7; WL = 8	3	4	4	Reserved	4	4
RL = 8; WL = 9	4	5	4	Reserved	5	5
RL = 9; WL = 10	4	5	5	Reserved	6	6
RL = 10; WL = 11	5	6	5	Reserved	6	6
RL = 11; WL = 12	5	6	6	Reserved	7	7
RL = 12; WL = 13	6	7	6	6	7	7
RL = 13; WL = 14	6	7	7	7	8	8
RL = 14; WL = 15	8	8	7	Reserved	9	9
RL = 15; WL = 16	8	8	8	Reserved	Reserved	10
RL = 16; WL = 17	8	9	Reserved	Reserved	Reserved	10

Data Latency

The data latency register uses MR0[7:4] to set both the READ and WRITE latency (RL and WL). The valid operating frequencies for each data latency register setting can be found in (page 0).

DLL Enable/Disable

Through the programming of MR0[8], the DLL can be enabled or disabled.

The DLL must be enabled for normal operation. The DLL must be enabled during the initialization routine and upon returning to normal operation after having been disabled for the purpose of debugging or evaluation. To operate the RLD RAM with the DLL disabled, the t_{RC_MRS} setting must equal the read latency (RL) setting. Enabling the DLL should always be followed by resetting the DLL using the appropriate MR1 command.

Address Multiplexing

Although the RLD RAM has the ability to operate similar to an SRAM interface by accepting the entire address in one clock (non-multiplexed, or broadside addressing), MR0[9] can be set to 1 so that it functions with multiplexed addressing, similar to a traditional DRAM. In multiplexed address mode, the address is provided to the RLD RAM in two parts that are latched into the memory with two consecutive rising edges of CK.

When in multiplexed address mode, only 11 address balls are required to control the RLD RAM, as opposed to 20 address balls when in non-multiplexed address mode. The data bus efficiency in continuous burst mode is only affected when using the BL = 2 setting because the device requires two clocks to read and write data. During multiplexed mode, the bank addresses as well as WRITE and READ commands are issued during the first address part, Ax. The Address Mapping in Multiplexed Address Mode table shows the addresses needed for both the first and second rising clock edges (Ax and Ay, respectively).

After MR0[9] is set HIGH, READ, WRITE, and MRS commands follow the format described in the Command Description in Multiplexed Address Mode figure. Refer to Multiplexed Address Mode for further information on operation with multiplexed addressing.

Mode Register 1 (MR1)

Figure 32: MR1 Definition for Non-Multiplexed Address Mode



- Notes:
1. BA2, BA3, and all address balls corresponding to reserved bits must be held LOW during the MRS command.
 2. BL8 not available in x36.

Output Drive Impedance

The RLD RAM 3 uses programmable impedance output buffers, which enable the user to match the driver impedance to the system. MR1[0] and MR1[1] are used to select 40Ω or 60Ω output impedance, but the device powers up with an output impedance of 40Ω. The drivers have symmetrical output impedance. To calibrate the impedance a 240Ω ±1% external precision resistor (RZQ) is connected between the ZQ ball and V_{SSQ}.

The output impedance is calibrated during initialization through the ZQCL mode register setting. Subsequent periodic calibrations (ZQCS) may be performed to compensate for shifts in output impedance due to changes in temperature and voltage. More detailed information on calibration can be found in the ZQ Calibration section.

DQ On-Die Termination (ODT)

MR1[4:2] are used to select the value of the on-die termination (ODT) for the DQ, DK_x and DM balls. When enabled, ODT terminates these balls to V_{DDQ}/2. The RLD RAM 3 device supports 40Ω, 60Ω, or 120Ω ODT. The ODT function is dynamically switched off when a DQ begins to drive after a READ command has been issued. Similarly, ODT is designed to switch on at the DQs after the RLD RAM has issued the last piece of data. The DM and DK_x balls are always terminated after ODT is enabled.

DLL Reset

Programming MR1[5] to 1 activates the DLL RESET function. MR1[5] is self-clearing, meaning it returns to a value of 0 after the DLL RESET function has been initiated.

Whenever the DLL RESET function is initiated, CK/CK# must be held stable for 512 clock cycles before a READ command can be issued. This is to allow time for the internal clock to be synchronized with the external clock. Failing to wait for synchronization to occur may cause output timing specifications, such as t_{CKQK} , to be invalid.

ZQ Calibration

The ZQ CALIBRATION mode register command is used to calibrate the DRAM output drivers (R_{ON}) and ODT values (R_{TT}) over process, voltage, and temperature, provided a dedicated 240Ω ($\pm 1\%$) external resistor is connected from the DRAM's RZQ ball to V_{SSQ} . Bit MR1[6] selects between ZQ calibration long (ZQCL) and ZQ calibration short (ZQCS), each of which are described in detail below. When bit MR1[7] is set HIGH, it enables the calibration sequence. Upon completion of the ZQ calibration sequence, MR1[7] automatically resets LOW.

The RLD RAM 3 needs a longer time to calibrate R_{ON} and ODT at power-up initialization and a relatively shorter time to perform periodic calibrations. An example of ZQ calibration timing is shown below.

All banks must have t_{RC} met before ZQCL or ZQCS mode register settings can be issued to the DRAM. No other activities (other than loading another ZQCL or ZQCS mode register setting may be issued to another DRAM) can be performed on the DRAM channel by the controller for the duration of t_{ZQinit} or t_{ZQoper} . The quiet time on the DRAM channel helps accurately calibrate R_{ON} and ODT. After DRAM calibration is achieved, the DRAM will disable the ZQ ball's current consumption path to reduce power.

ZQ CALIBRATION mode register settings can be loaded in parallel to DLL reset and locking time.

In systems that share the ZQ resistor between devices, the controller must not allow overlap of t_{ZQinit} , t_{ZQoper} , or t_{ZQcs} between devices.

Figure 33: ZQ Calibration Timing (ZQCL and ZQCS)



- Notes:
1. All devices connected to the DQ bus should be held High-Z during calibration.
 2. The state of QK and QK# are unknown during ZQ calibration.
 3. t_{MRSC} after loading the MR1 settings, QVLD output drive strength will be at the value selected or higher (lower resistance) until ZQ calibration is complete.

ZQ Calibration Long

The ZQ calibration long (ZQCL) mode register setting is used to perform the initial calibration during a power-up initialization and reset sequence. It may be loaded at any time by the controller depending on the system environment. ZQCL triggers the calibration engine inside the DRAM. After calibration is achieved, the calibrated values are transferred from the calibration engine to the DRAM I/O, which are reflected as updated R_{ON} and ODT values.

The DRAM is allowed a timing window defined by either t_{ZQinit} or t_{ZQoper} to perform the full calibration and transfer of values. When ZQCL is issued during the initialization sequence, the timing parameter t_{ZQinit} must be satisfied. When initialization is complete, subsequent loading of the ZQCL mode register setting requires the timing parameter t_{ZQoper} to be satisfied.

ZQ Calibration Short

The ZQ calibration short (ZQCS) mode register setting is used to perform periodic calibrations to account for small voltage and temperature variations. The shorter timing window is provided to perform the reduced calibration and transfer of values as defined by timing parameter t_{ZQCS} . ZQCS can effectively correct a minimum of 0.5% R_{ON} and R_{TT} impedance error within 64 clock cycles, assuming the maximum sensitivities specified in the ODT Temperature and Voltage Sensitivity and the Output Driver Voltage and Temperature Sensitivity tables.

AUTO REFRESH Protocol

The AUTO REFRESH (AREF) protocol is selected with bit MR1[8]. There are two ways in which AREF commands can be issued to the RLD RAM. Depending upon how bit MR1[8] is programmed, the memory controller can issue either bank address-controlled or multibank AREF commands. Bank address-controlled AREF uses the BA[3:0] inputs to refresh a single bank per command. Multibank AREF is enabled by setting bit MR1[8] HIGH during an MRS command. This refresh protocol enables the simultaneous refreshing of a row in up to four banks. In this method, the address pins A[15:0] represent banks 0–15, respectively. More information on both AREF protocols can be found in AUTO REFRESH Command (page 84).

Burst Length (BL)

Burst length is defined by MR1[9] and MR1[10]. Read and write accesses to the RLD RAM are burst-oriented, with the burst length being programmable to 2, 4, or 8. Figure 34 (page 78) shows the different burst lengths with respect to a READ command. Changes in the burst length affect the width of the address bus (see the following table for details).

The data written by the prior burst length is not guaranteed to be accurate when the burst length of the device is changed.

Table 43: Address Widths of Different Burst Lengths

Burst Length	Configuration	
	x18	x36
2	A[19:0]	A[18:0]
4	A[18:0]	A[17:0]
8	A[17:0]	NA

Figure 34: Read Burst Lengths

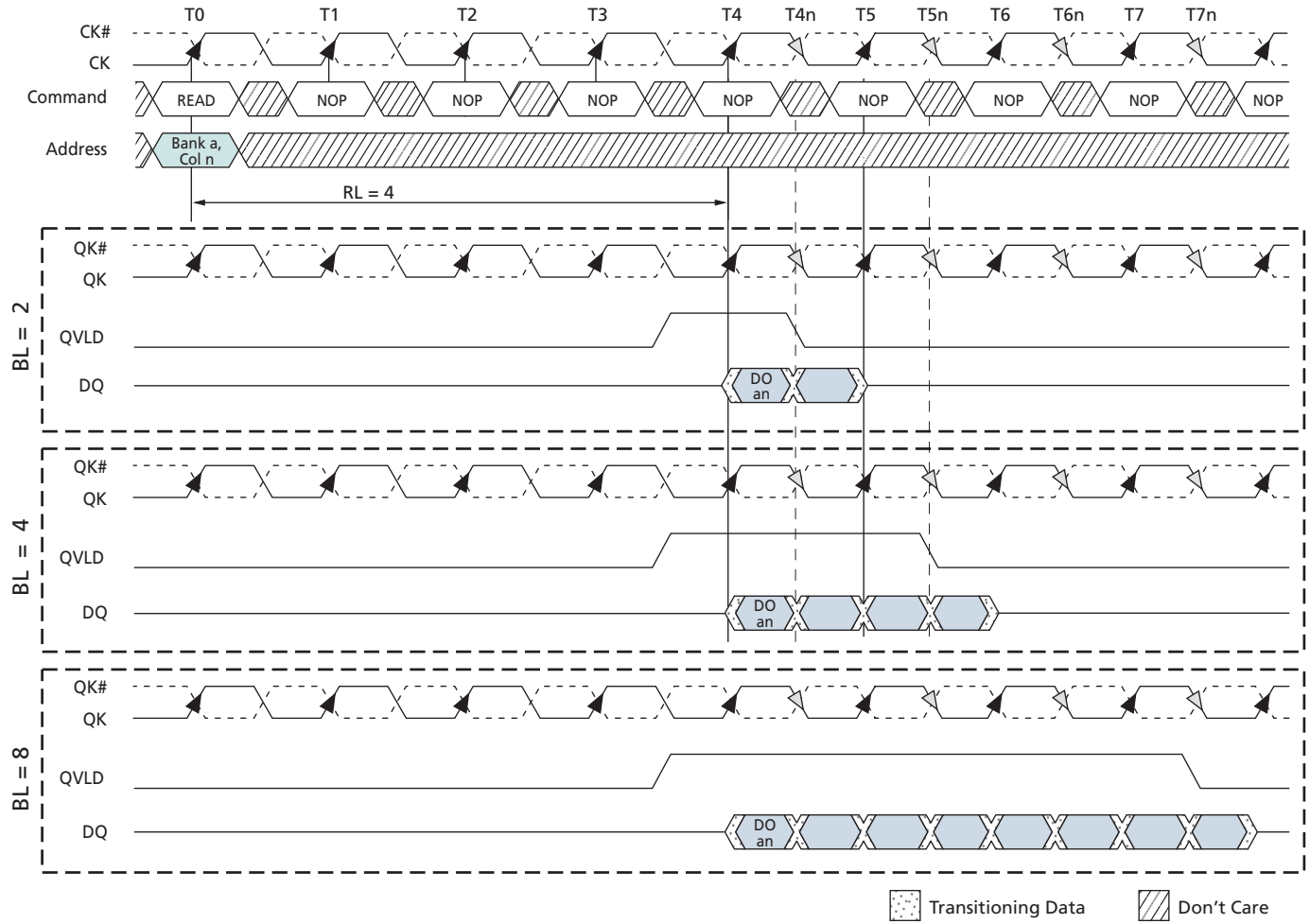

Note: 1. DO an = data-out from bank a and address an.

Mode Register 2 (MR2)

Figure 35: MR2 Definition for Non-Multiplexed Address Mode



Note: 1. BA2, BA3, and all address balls corresponding to reserved bits must be held LOW during the MRS command.

READ Training Register (RTR)

The READ training register (RTR) is controlled through MR2[2:0]. It is used to output a predefined bit sequence on the output balls to aid in system timing calibration. MR2[2] is the master bit that enables or disables access to the READ training register, and MR2[1:0] determine which predefined pattern for system calibration is selected. If MR2[2] is set to 0, the RTR is disabled, and the DRAM operates in normal mode. When MR2[2] is set to 1, the DRAM no longer outputs normal read data, but a predefined pattern that is defined by MR2[1:0].

Prior to enabling the RTR, all banks must be in the idle state (^tRC met). When the RTR is enabled, all subsequent READ commands will output four bits of a predefined sequence from the RTR on all DQs. The READ latency during RTR is defined with the Data Latency bits in MR0. To loop on the predefined pattern when the RTR is enabled, successive READ commands must be issued and satisfy ^tRTRS. Address balls A[19:0] are considered "Don't Care" during RTR READ commands. Bank address bits BA[3:0] must access Bank 0 with each RTR READ command. ^tRC does not need to be met in between RTR READ commands to Bank 0. When the RTR is enabled, only READ commands are allowed. When the last RTR READ burst has completed and ^tRTRE has been satisfied, an MRS command can be issued to exit the RTR. Standard RLD RAM 3 operation may then start after ^tMRSC has been met. The RESET function is supported when the RTR is enabled.

If MR2[1:0] is set to 00 a 0-1-0-1 pattern will be output on all DQs with each RTR READ command. If MR2[1:0] is set to 01, a 0-1-0-1 pattern will output on all even DQs and the opposite pattern, a 1-0-1-0, will output on all odd DQs with each RTR READ command.

Enabling RTR may corrupt previously written data.

Figure 36: READ Training Function - Back-to-Back Readout



Note: 1. RL = READ latency defined with data latency MR0 setting.

WRITE Protocol

Single or multibank WRITE operation is programmed with bits MR2[4:3]. The purpose of multibank WRITE operation is to reduce the effective t_{RC} during READ commands. When dual- or quad-bank WRITE protocol is selected, identical data is written to two or four banks, respectively. With the same data stored in multiple banks on the RLD RAM, the memory controller can select the appropriate bank to READ the data from and minimize t_{RC} delay. Detailed information on the multibank WRITE protocol can be found in Multibank WRITE (page 82).

WRITE Command

Write accesses are initiated with a WRITE command. The address needs to be provided concurrent with the WRITE command.

During WRITE commands, data will be registered at both edges of DK, according to the programmed burst length (BL). The RLD RAM operates with a WRITE latency (WL) determined by the data latency bits within MR0. The first valid data is registered at the first rising DK edge WL cycles after the WRITE command.

Any WRITE burst may be followed by a subsequent READ command (assuming t_{RC} is met). Depending on the amount of input timing skew, an additional NOP command might be necessary between WRITE and READ commands to avoid external data bus contention (see Figure 44 (page 89)).

Setup and hold times for incoming DQ relative to the DK edges are specified as t_{DS} and t_{DH} . The input data is masked if the corresponding DM signal is HIGH.

Figure 37: WRITE Command

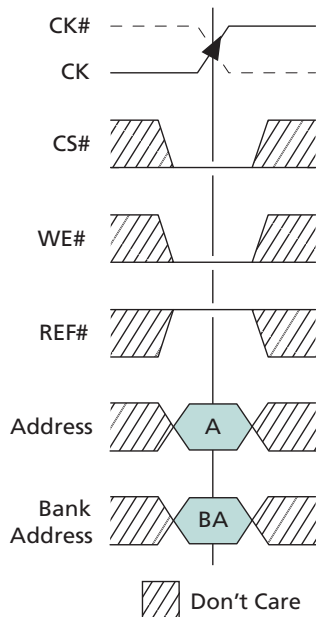

Multibank WRITE

All the information provided above in the WRITE section is applicable to a multibank WRITE operation as well. Either two or four banks can be simultaneously written to when the appropriate MR2[4:3] mode register bits are selected.

If a dual-bank WRITE has been selected through the mode register, both banks x and $x+8$ will be written to simultaneously with identical data provided during the WRITE command. For example, when a dual-bank WRITE has been loaded and the bank address for Bank 1 has been provided during the WRITE command, Bank 9 will also be written to at the same time. When a dual-bank WRITE command is issued, only bank address bits BA[2:0] are valid and BA3 is considered a “Don’t Care.”

The same methodology is used if the quad-bank WRITE has been selected through the mode register. Under these conditions, when a WRITE command is issued to Bank x , the data provided on the DQs will be issued to banks x , $x+4$, $x+8$, and $x+12$. When a quad-bank WRITE command is issued, only bank address bits BA[1:0] are valid and BA[3:2] are considered “Don’t Care.”

The timing parameter t_{SAW} must be adhered to when operating with multibank WRITE commands. This parameter limits the number of active banks at 16 within an 8ns window. The t_{MMD} specification must also be followed if the quad-bank WRITE is being used. This specification requires two clock cycles between any bank command (READ, WRITE, or AREF) to a quad-bank WRITE or a quad-bank WRITE to any bank command. The data bus efficiency is not compromised if BL4 or BL8 is being utilized.

READ Command

Read accesses are initiated with a READ command (see the figure below). Addresses are provided with the READ command.

During READ bursts, the memory device drives the read data so it is edge-aligned with the QK signals. After a programmable READ latency, data is available at the outputs. One half clock cycle prior to valid data on the read bus, the data valid signal(s), QVLD, transitions from LOW to HIGH. QVLD is also edge-aligned with the QK signals.

The skew between QK and the crossing point of CK is specified as t_{CKQK} . t_{QKQx} is the skew between a QK pair and the last valid data edge generated at the DQ signals in the associated byte group, such as DQ[7:0] and QK0. t_{QKQx} is derived at each QK clock edge and is not cumulative over time. For the x36 device, the t_{QKQ02} and t_{QKQ13} specifications define the relationship between the DQs and QK signals within specific data word groupings. t_{QKQ02} defines the skew between QK0 and DQ[26:18] and between QK2 and DQ[8:0]. t_{QKQ13} defines the skew between QK1 and DQ[35:17] and between QK3 and DQ[17:9].

After completion of a burst, assuming no other commands have been initiated, output data (DQ) will go High-Z. The QVLD signal transitions LOW on the last bit of the READ burst. The QK clocks are free-running and will continue to cycle after the read burst is complete. Back-to-back READ commands are possible, producing a continuous flow of output data.

Any READ burst may be followed by a subsequent WRITE command. Some systems having long line lengths or severe skews may need an additional idle cycle inserted between READ and WRITE commands to prevent data bus contention.

Figure 38: READ Command



AUTO REFRESH Command

The RLD RAM 3 device uses two unique AUTO REFRESH (AREF) command protocols, bank address-controlled AREF and multibank AREF. The desired protocol is selected by setting MR1[8] LOW (for bank address-controlled AREF) or HIGH (for multibank AREF) during an MRS command. Bank address-controlled AREF is identical to the method used in RLD RAM2 devices, whereby banks are refreshed independently. The value on bank addresses BA[3:0], issued concurrently with the AREF command, define which bank is to be refreshed. The array address is generated by an internal refresh counter, effectively making each address bit a "Don't Care" during the AREF command. The delay between the AREF command and a subsequent command to the same bank must be at least t_{RC} .

Figure 39: Bank Address-Controlled AUTO REFRESH Command

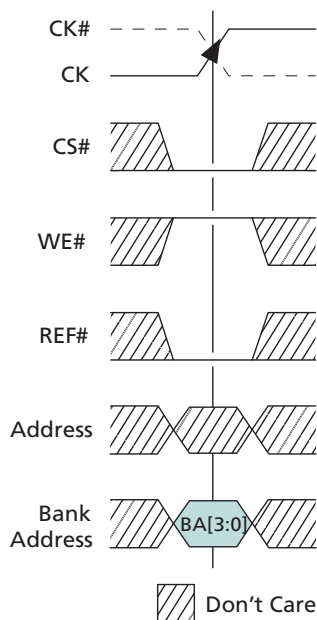

The multibank AREF protocol, enabled by setting bit MR1[8] HIGH during an MRS command, enables the simultaneous refresh of a row in up to four banks. In this method, address balls A[15:0] represent banks [15:0], respectively. The row addresses are generated by an internal refresh counter for each bank; therefore, the purpose of the address balls during an AREF command is only to identify the banks to be refreshed. The bank address balls BA[3:0] are considered "Don't Care" during a multibank AREF command.

A multibank AUTO REFRESH is performed for a given bank when its corresponding address ball is asserted HIGH during an AREF command. Any combination of up to four address balls can be asserted HIGH during the rising clock edge of an AREF command to simultaneously refresh a row in each corresponding bank. The delay between an AREF command and subsequent commands to the banks refreshed must be at least t_{RC} . Adherence to t_{SAW} must be followed when simultaneously refreshing multiple banks. If refreshing three or four banks with the multibank AREF command, t_{MMD} must be followed. This specification requires two clock cycles between any bank command (READ, WRITE, AREF) to the multibank AREF or the multibank AREF to any bank

command. Note that refreshing one or two banks with the multibank AREF command is not subject to the t_{MMD} specification.

The entire device must be refreshed every 64ms (t_{REF}). The RLD RAM device requires 128K cycles at an average periodic interval of 0.489 μ s MAX (64ms/[8K rows x 16 banks]).

To allow for improved efficiency in scheduling and switching between tasks, some flexibility in the absolute refresh interval is provided. A maximum of 128 subsequent refresh commands can be issued as long as these commands are distributed among all 16 banks with no more than 8 refreshes per bank. Every access must ensure that t_{RC} of the bank has been met and no more than 128 refreshes can be issued within 128 x average periodic interval of 0.489 μ s (128 x 0.489 μ s = 62.59 μ s).

Figure 40: Multibank AUTO REFRESH Command



INITIALIZATION Operation

The RLD RAM 3 device must be powered up and initialized in a predefined manner. Operational procedures other than those specified may result in undefined operations or permanent damage to the device.

The following sequence is used for power-up:

1. Ensure that RESET# is below $0.2 \times V_{DDQ}$ during power ramp to ensure the outputs remain disabled (High-Z) and ODT is off (R_{TT} is also High-Z). DQs and QK signals will remain High-Z until MR0 command. TCK must remain stable during the power ramp, initialization, and non JTAG operation. All other inputs may be undefined during the power ramp.
2. Apply power (V_{EXT} , V_{DD} , V_{DDQ}). Apply V_{DD} and V_{EXT} before, or at the same time as, V_{DDQ} . V_{DD} must not exceed V_{EXT} during power supply ramp. Micron strongly recommends that V_{DD} and V_{DDQ} be ramped up at the same time. V_{EXT} , V_{DD} , V_{DDQ} must all ramp to their respective minimum DC levels within 200ms.
3. After the power is stable, RESET# must remain LOW for at least 200 μ s prior to beginning the initialization process.
4. After 100 or more stable input clock cycles with NOP commands, bring RESET# HIGH.
5. After RESET# goes HIGH, a stable clock must be applied in conjunction with NOP commands and all address pins, including the bank address pins to be held LOW for 10,000 cycles.
6. Load desired settings into MR0.
7. t_{MRSC} after loading the MR0 settings, load operating parameters in MR1, including DLL reset and long ZQ calibration.
8. After the DLL is reset and long ZQ calibration is enabled, the input clock must be stable for t_{ZQinit} clock cycles while NOPs are issued.
9. Load desired settings into MR2. If using the RTR, follow the procedure outlined in the READ Training Function – Back-to-Back Readout figure prior to entering normal operation.
10. The RLD RAM 3 is ready for normal operation.

Figure 41: Power-Up/Initialization Sequence



- Notes: 1. QVLD output drive status during power-up and initialization:
- QVLD will remain at High-Z while $RESET\#$ is LOW.
 - After $RESET\#$ goes HIGH, QVLD will transition LOW after approximately 20ns.
 - QVLD will then continue to drive LOW with 40Ω or lower until MR0 is enabled. After MR0 has been enabled, the state of QVLD becomes unknown.

- d. QVLD will meet the output drive strength specifications when the ZQ calibration is complete.
- 2. After MR2 has been issued, R_{TT} is either High-Z or enabled to the ODT value selected in MR1.

WRITE Operation

Figure 42: WRITE Burst



Note: 1. DI an = data-in for bank a and address n.

Figure 43: Consecutive WRITE Bursts



Note: 1. DI an (or bn or cn) = data-in for bank a (or b or c) and address n.

Figure 44: WRITE-to-READ



Notes: 1. DI an = data-in for bank a and address n.

2. DO bn = data-out from bank b and address n .

Figure 45: WRITE - DM Operation



Note: 1. DI an = data-in for bank a and address n .

Figure 46: Consecutive Quad Bank WRITE Bursts



Notes: 1. DI an = data-in for bank a , $a+4$, $a+8$, and $a+12$ and address n .
2. DI bn = data-in for bank b , $b+4$, $b+8$, and $b+12$ and address n .

Figure 47: Interleaved READ and Quad Bank WRITE Bursts

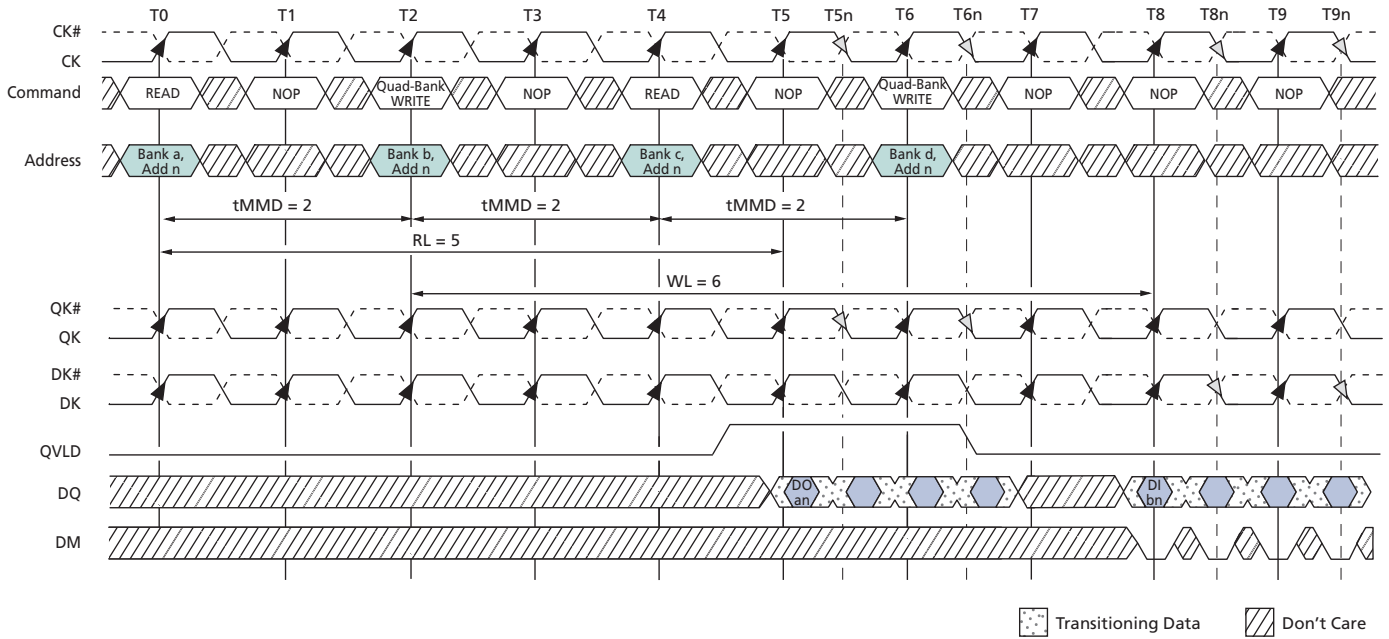

- Notes: 1. DO an = data-out for bank a and address n .
2. DI bn = data-in for bank b , $b+4$, $b+8$, and $b+12$ and address n .

READ Operation

Figure 48: Basic READ Burst



Note: 1. DO an = data-out from bank a and address n.

Figure 49: Consecutive READ Bursts (BL = 2)

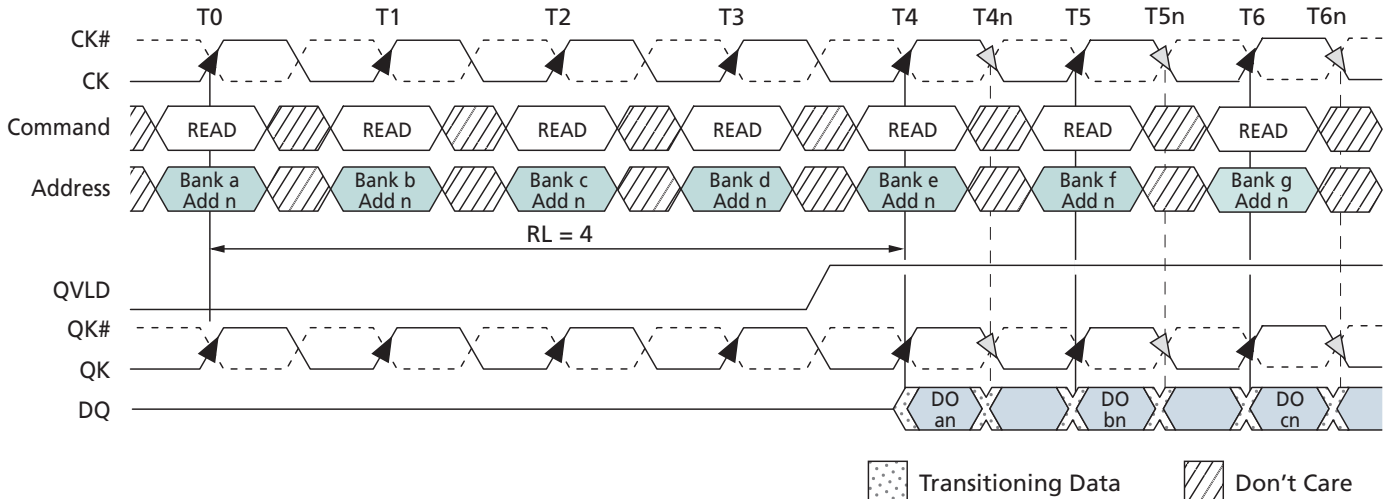

Note: 1. DO an (or bn, cn) = data-out from bank a (or bank b, c) and address n.

Figure 50: Consecutive READ Bursts (BL = 4)



Note: 1. DO an (or bn) = data-out from bank a (or bank b) and address n.

Figure 51: READ-to-WRITE (BL = 2)

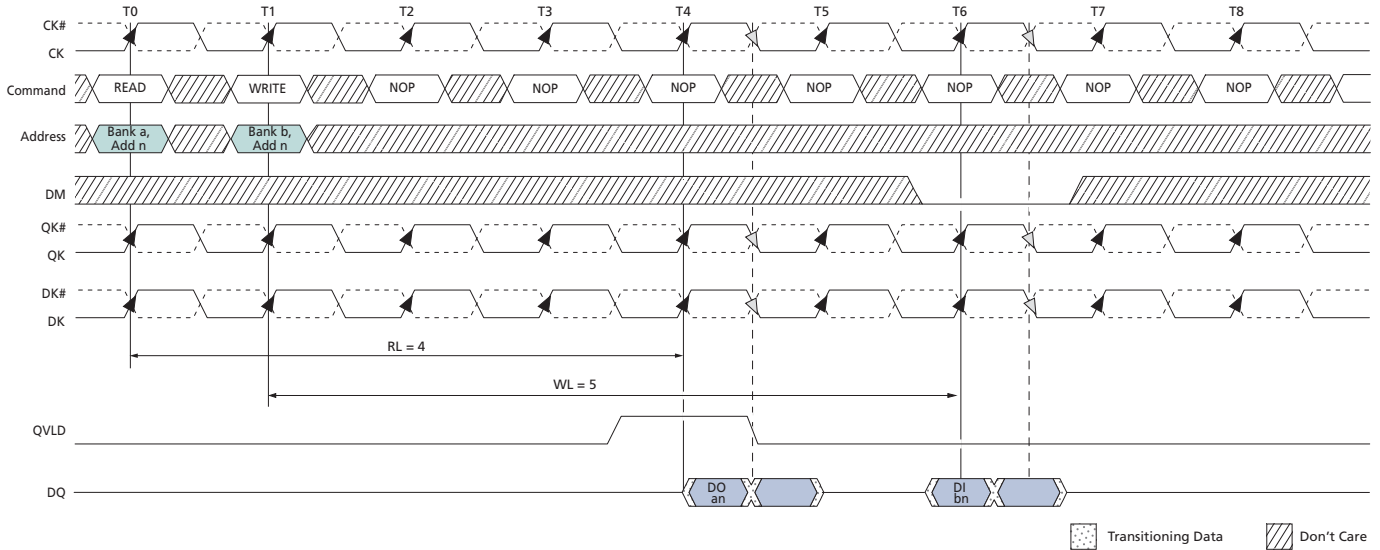

- Notes: 1. DO an = data-out from bank a and address n .
2. DI bn = data-in for bank b and address n .

Figure 52: Read Data Valid Window

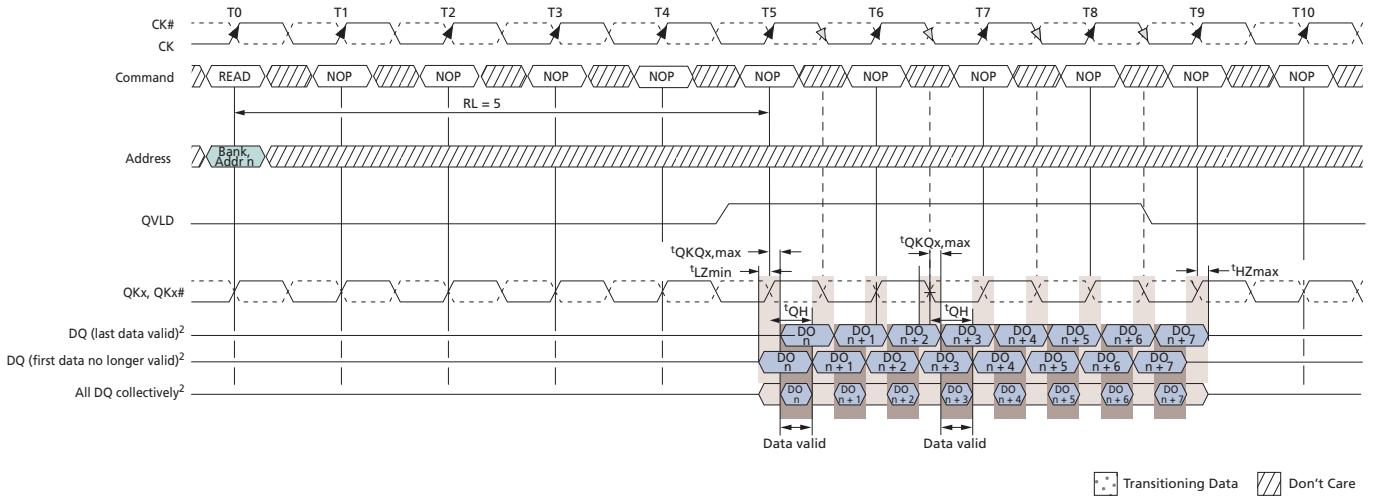

- Notes: 1. DO n = data-out from bank a and address n .
2. Represents DQs associated with a specific QK, QK# pair.
3. Output timings are referenced to $V_{DDQ}/2$ and DLL on and locked.
4. t_{QKQx} defines the skew between the QK0, QK# pair to its respective DQs. t_{QKQx} does not define the skew between QK and CK.
5. Early data transitions may not always happen at the same DQ. Data transitions of a DQ can vary (either early or late) within a burst.

AUTO REFRESH Operation

Figure 53: Bank Address-Controlled AUTO REFRESH Cycle



- Notes:
1. AREFx (or AREFy) = AUTO REFRESH command to bank x (or bank y).
 2. ACx = any command to bank x; ACy = any command to bank y.
 3. BAx = bank address to bank x; BAy = bank address to bank y.

Figure 54: Multibank AUTO REFRESH Cycle

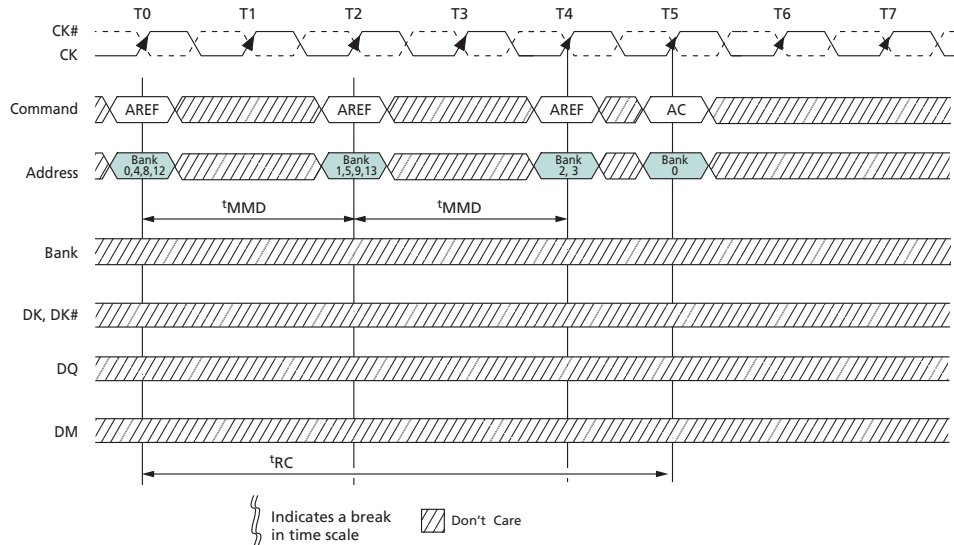

Figure 55: READ Burst with ODT



Note: 1. DO an = data out from bank a and address n.

Figure 56: READ-NOP-READ with ODT



Note: 1. DO an (or bn) = data-out from bank a (or bank b) and address n.

RESET Operation

The RESET signal (RESET#) is an asynchronous signal that triggers any time it drops LOW. There are no restrictions for when it can go LOW. After RESET# goes LOW, it must remain LOW for 100ns. During this time, the outputs are disabled, ODT (R_{TT}) turns off (High-Z), and the DRAM resets itself. Prior to RESET# going HIGH, at least 100 stable CK cycles with NOP commands must be given to the RLD RAM. After RESET# goes HIGH, the DRAM must be reinitialized as though a normal power-up was executed. All refresh counters on the DRAM are reset, and data stored in the DRAM is assumed unknown after RESET# has gone LOW.

Figure 57: RESET Sequence

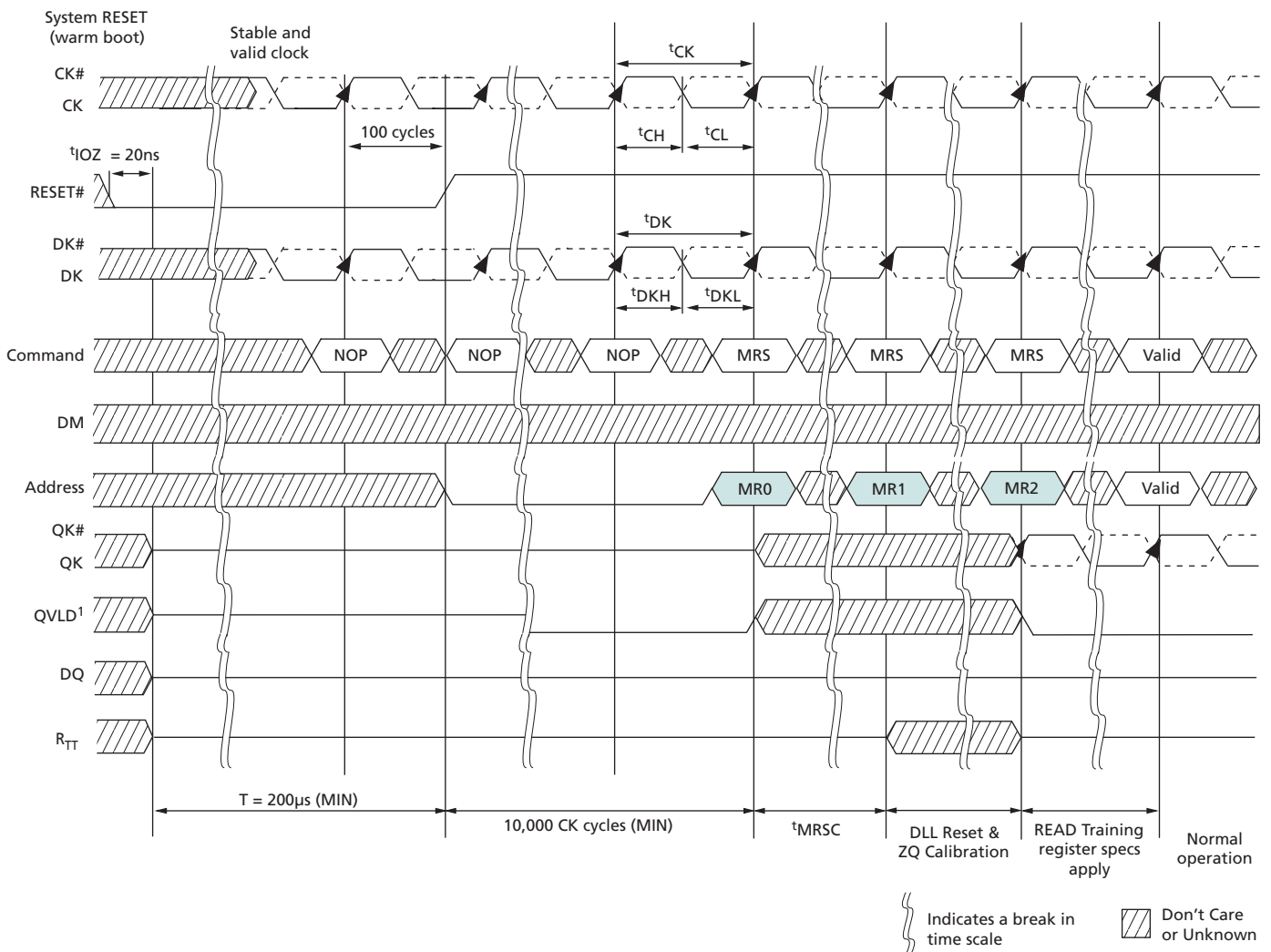

Clock Stop

If the clock is stopped or suspended after normal operation has begun, the RESET# pin must be asserted and the device reinitialized, before normal operation can continue. Refer to the RESET and INITIALIZATION Operation sections for more detail. All refresh counters on the DRAM are reset, and data stored in the DRAM is assumed unknown after RESET# has gone LOW.

Mirror Function

The mirror function ball (MF) is a DC input used to create mirrored ballouts for simple dual-loaded clamshell mounting. If the MF ball is tied LOW, the address and command balls are in their true layout. If the MF ball is tied HIGH, the address and command balls are mirrored around the central y-axis (column 7). The following table shows the ball assignments when the MF ball is tied HIGH for a x18 device. Compare that table to Table 1 (page 13) to see how the address and command balls are mirrored. The same balls are mirrored on the x36 device.

Table 44: 32 Meg x 18 Ball Assignments with MF Ball Tied HIGH

	1	2	3	4	5	6	7	8	9	10	11	12	13
A		V _{SS}	V _{DD}	NF	V _{DDQ}	NF	V _{REF}	DQ7	V _{DDQ}	DQ8	V _{DD}	V _{SS}	RESET#
B	V _{EXT}	V _{SS}	NF	V _{SSQ}	NF	V _{DDQ}	DM0	V _{DDQ}	DQ5	V _{SSQ}	DQ6	V _{SS}	V _{EXT}
C	V _{DD}	NF	V _{DDQ}	NF	V _{SSQ}	NF	DK0#	DQ2	V _{SSQ}	DQ3	V _{DDQ}	DQ4	V _{DD}
D	A13	V _{SSQ}	NF	V _{DDQ}	NF	V _{SSQ}	DK0	V _{SSQ}	QK0	V _{DDQ}	DQ0	V _{SSQ}	A11
E	V _{SS}	CS#	V _{SSQ}	NF	V _{DDQ}	NF	MF	QK0#	V _{DDQ}	DQ1	V _{SSQ}	A0	V _{SS}
F	A9	A5	V _{DD}	A4	A3	REF#	ZQ	WE#	A1	A2	V _{DD}	NF	A7
G	V _{SS}	A18	A8	V _{SS}	BA0	V _{SS}	CK#	V _{SS}	BA1	V _{SS}	A6	A15	V _{SS}
H	A10	V _{DD}	A12	A17	V _{DD}	BA2	CK	BA3	V _{DD}	A16	A14	V _{DD}	A19
J	V _{DDQ}	NF	V _{SSQ}	NF	V _{DDQ}	NF	V _{SS}	QK1#	V _{DDQ}	DQ9	V _{SSQ}	QVLD	V _{DDQ}
K	NF	V _{SSQ}	NF	V _{DDQ}	NF	V _{SSQ}	DK1	V _{SSQ}	QK1	V _{DDQ}	DQ10	V _{SSQ}	DQ11
L	V _{DD}	NF	V _{DDQ}	NF	V _{SSQ}	NF	DK1#	DQ12	V _{SSQ}	DQ13	V _{DDQ}	DQ14	V _{DD}
M	V _{EXT}	V _{SS}	NF	V _{SSQ}	NF	V _{DDQ}	DM1	V _{DDQ}	DQ15	V _{SSQ}	DQ16	V _{SS}	V _{EXT}
N	V _{SS}	TCK	V _{DD}	TDO	V _{DDQ}	NF	V _{REF}	DQ17	V _{DDQ}	TDI	V _{DD}	TMS	V _{SS}

Multiplexed Address Mode

Figure 58: Command Description in Multiplexed Address Mode

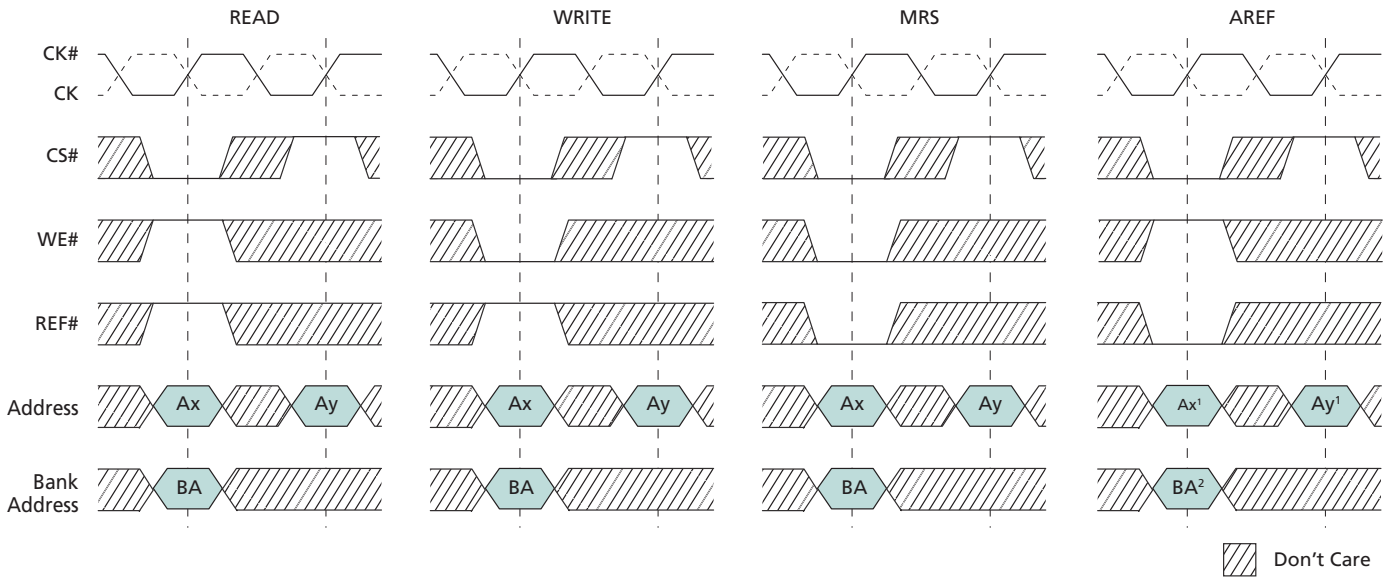

- Notes:
1. Addresses valid only during a multibank AUTO REFRESH command.
 2. Bank addresses valid only during a bank address-controlled AUTO REFRESH command.
 3. The minimum setup and hold times of the two address parts are defined as t_{IS} and t_{IH} .

Figure 59: Power-Up/Initialization Sequence in Multiplexed Address Mode

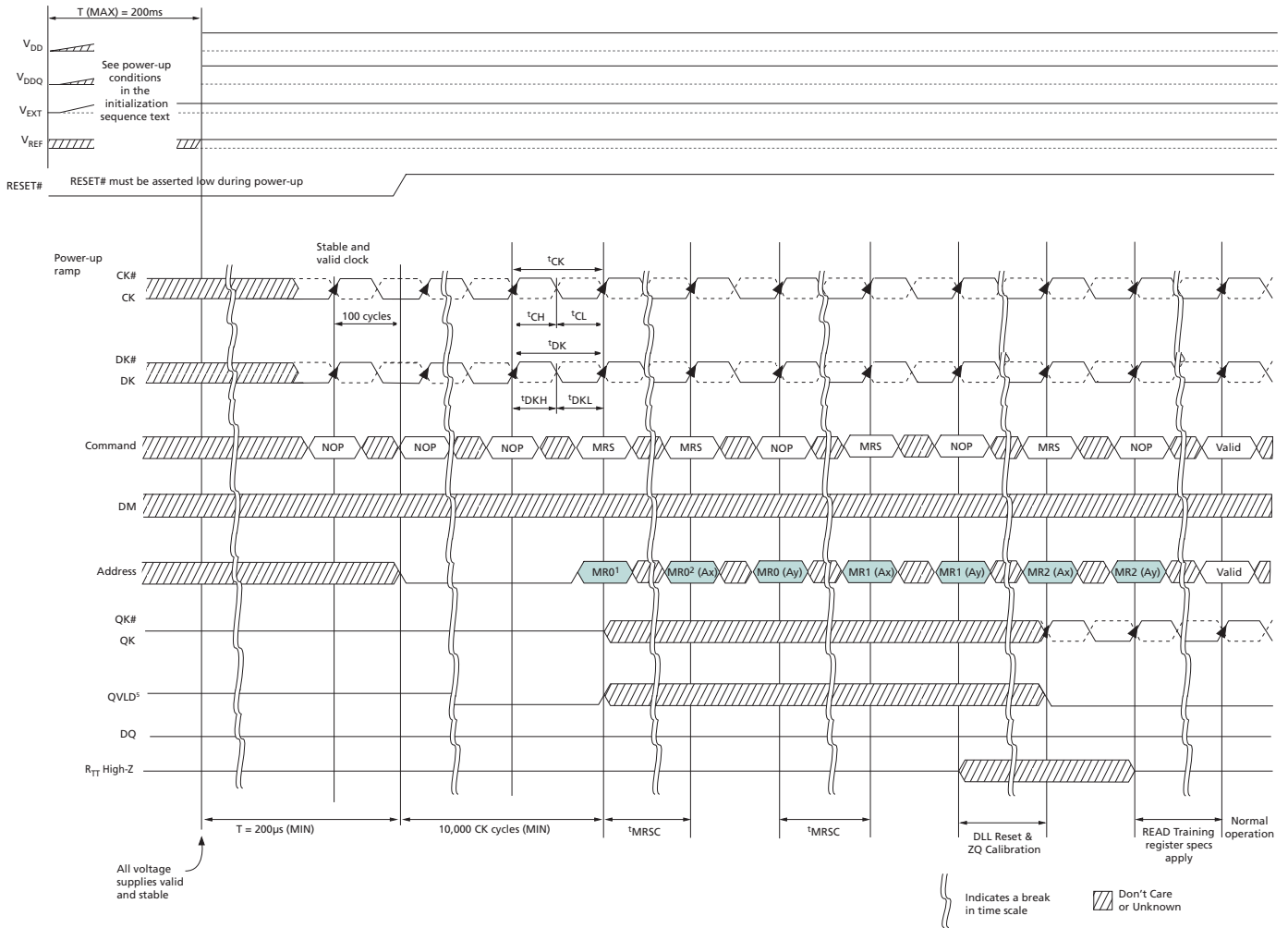

- Notes:**
1. Set address bit MR0[9] HIGH. This enables the device to enter multiplexed address mode when in non-multiplexed mode operation. Multiplexed address mode can also be entered at a later time by issuing an MRS command with MR0[9] HIGH. After address bit MR0[9] is set HIGH, t_{MRSC} must be satisfied before the two-cycle multiplexed mode MRS command is issued.
 2. Address MR0[9] must be set HIGH. This and the following step set the desired MR0 setting after the RLD RAM device is in multiplexed address mode.
 3. MR1 (Ax), MR1 (Ay), MR2 (Ax), and MR2 (Ay) represent MR1 and MR2 settings in multiplexed address mode.
 4. The above sequence must be followed in order to power up the RLD RAM device in the multiplexed address mode.
 5. See QVLD output drive strength status during power up and initialization in non-multiplexed initialization operation section.
 6. After MR2 has been issued, R_{TT} is either High-Z or enabled to the ODT value selected in MR1.

Figure 60: MR0 Definition for Multiplexed Address Mode

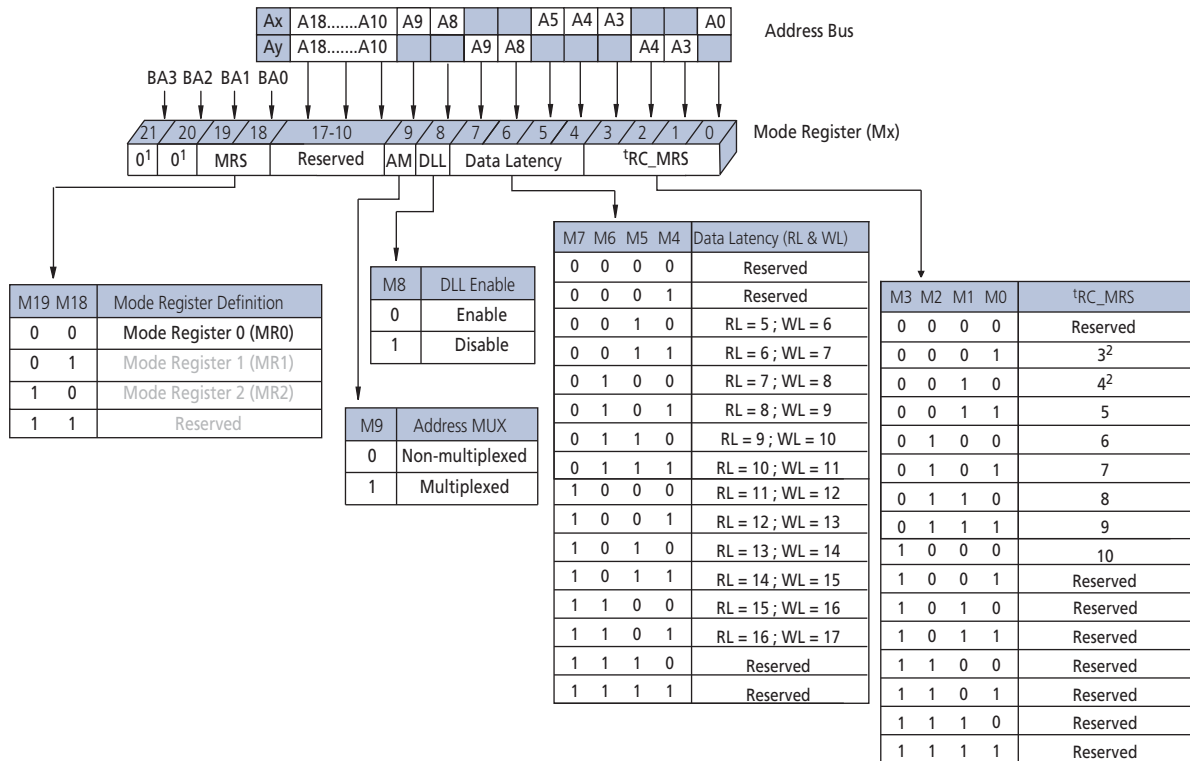

- Notes: 1. BA2, BA3, and all address balls corresponding to reserved bits must be held LOW during the MRS command.
2. BL8 not allowed.

Figure 61: MR1 Definition for Multiplexed Address Mode

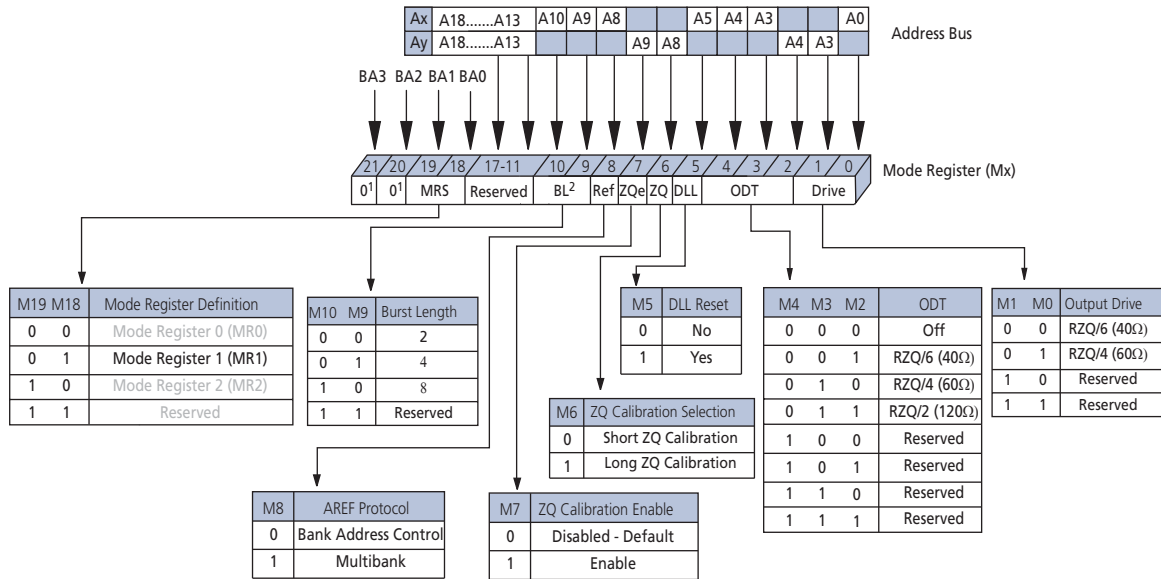

- Notes:
1. BA2, BA3, and all address balls corresponding to reserved bits must be held LOW during the MRS command.
 2. BL8 not available in x36.

Figure 62: MR2 Definition for Multiplexed Address Mode



Note: 1. BA2, BA3, and all address balls corresponding to reserved bits must be held LOW during the MRS command.

Table 45: Address Mapping in Multiplexed Address Mode

Data Width	Burst Length	Ball	Address										
			A0	A3	A4	A5	A8	A9	A10	A13	A14	A17	A18
x36	2	Ax	A0	A3	A4	A5	A8	A9	A10	A13	A14	A17	A18
		Ay	X	A1	A2	X	A6	A7	X	A11	A12	A16	A15
	4	Ax	A0	A3	A4	A5	A8	A9	A10	A13	A14	A17	X
		Ay	X	A1	A2	X	A6	A7	X	A11	A12	A16	A15
x18	2	Ax	A0	A3	A4	A5	A8	A9	A10	A13	A14	A17	A18
		Ay	X	A1	A2	X	A6	A7	A19	A11	A12	A16	A15
	4	Ax	A0	A3	A4	A5	A8	A9	A10	A13	A14	A17	A18
		Ay	X	A1	A2	X	A6	A7	X	A11	A12	A16	A15
	8	Ax	A0	A3	A4	A5	A8	A9	A10	A13	A14	A17	X
		Ay	X	A1	A2	X	A6	A7	X	A11	A12	A16	A15

Note: 1. X = "Don't Care"

Data Latency in Multiplexed Address Mode

When in multiplexed address mode, data latency (READ and WRITE) begins when the A_y part of the address is issued with any READ or WRITE command. t_{RC} is measured from the clock edge in which the command and A_x part of the address is issued in both multiplexed and non-multiplexed address mode.

REFRESH Command in Multiplexed Address Mode

Similar to other commands when in multiplexed address mode, both modes of AREF (single and multibank) are executed on the rising clock edge, following the one on which the command is issued. However, when in bank address-controlled AREF, as only the bank address is required, the next command can be applied on the following clock. When using multibank AREF, the bank addresses are mapped across A_x and A_y so a subsequent command cannot be issued until two clock cycles later.

Figure 63: Bank Address-Controlled AUTO REFRESH Operation with Multiplexed Addressing

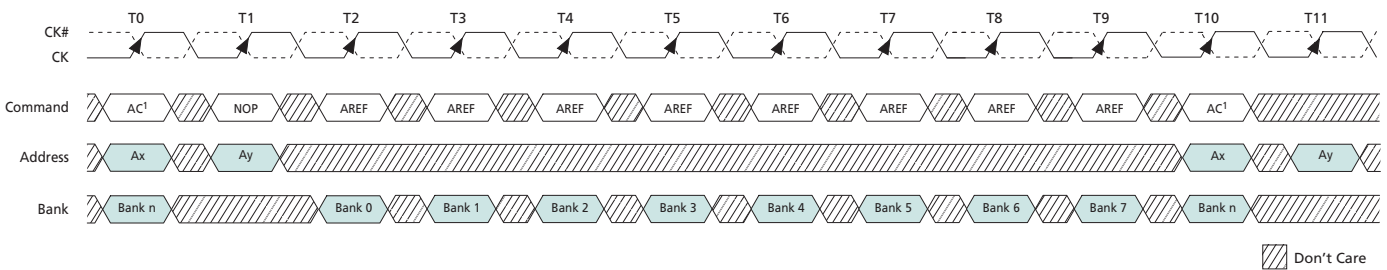

Note: 1. Any command subject to t_{RC} specification.

Figure 64: Multibank AUTO REFRESH Operation with Multiplexed Addressing

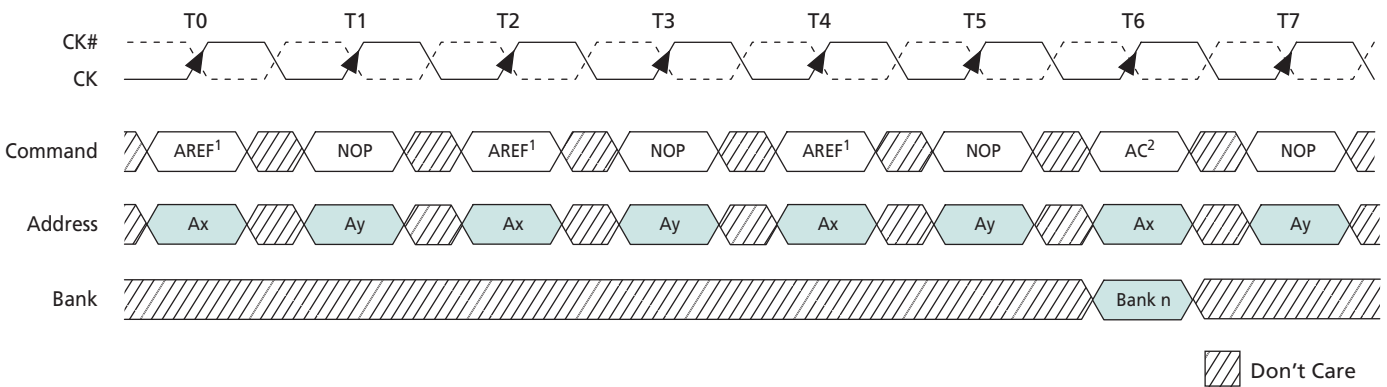

Notes: 1. Usage of multibank AREF subject to t_{SAW} and t_{MMD} specifications.
2. Any command subject to t_{RC} specification.

Figure 65: Consecutive WRITE Bursts with Multiplexed Addressing



Note: 1. DI a = data-in for bank a; DI b = data-in for bank b.

Figure 66: WRITE-to-READ with Multiplexed Addressing



Note: 1. DI a = data-in for bank a; DI b = data-in for bank b.

Figure 67: Consecutive READ Bursts with Multiplexed Addressing



Note: 1. DO a = data-out for bank a.

Figure 68: READ-to-WRITE with Multiplexed Addressing



Note: 1. DO a = data-out for bank a; DI b = data-in for bank b.

IEEE 1149.1 Serial Boundary Scan (JTAG)

The RLD RAM 3 device incorporates a serial boundary-scan test access port (TAP) for the purpose of testing the connectivity of the device after it has been mounted on a printed circuit board (PCB). As the complexity of PCB high-density surface mounting techniques increases, the boundary-scan architecture is a valuable resource for interconnectivity debug. This port operates in accordance with IEEE Standard 1149.1-2001 (JTAG) with the exception of the ZQ pin. To ensure proper boundary-scan testing of the ZQ pin, MR1[7] needs to be set to 0 until the JTAG testing of the pin is complete. Note that upon power up, the default state of the MRS bit M1[7] is low.

The JTAG test access port utilizes the TAP controller on the device, from which the instruction register, boundary-scan register, bypass register, and ID register can be selected. Each of these functions of the TAP controller is described in detail below.

Disabling the JTAG Feature

It is possible to operate an RLD RAM 3 device without using the JTAG feature. To disable the TAP controller, TCK must be tied LOW (V_{SS}) to prevent clocking of the device. TDI and TMS are internally pulled up and may be unconnected. They may alternately be connected to V_{DDQ} through a pull-up resistor. TDO should be left unconnected. Upon power-up, the device will come up in a reset state, which will not interfere with the operation of the device.

Test Access Port (TAP)

Test Clock (TCK)

The test clock is used only with the TAP controller. All inputs are captured on the rising edge of TCK. All outputs are driven from the falling edge of TCK.

Test Mode Select (TMS)

The TMS input is used to give commands to the TAP controller and is sampled on the rising edge of TCK.

All the states in Figure 69 (page 112) are entered through the serial input of the TMS ball. A 0 in the diagram represents a LOW on the TMS ball during the rising edge of TCK, while a 1 represents a HIGH on TMS.

Test Data-In (TDI)

The TDI ball is used to serially input test instructions and data into the registers and can be connected to the input of any of the registers. The register between TDI and TDO is chosen by the instruction that is loaded into the TAP instruction register. For information on loading the instruction register, see Figure 69 (page 112). TDI is connected to the most significant bit (MSB) of any register (see Figure 70 (page 112)).

Test Data-Out (TDO)

The TDO output ball is used to serially clock test instructions and data out from the registers. The TDO output driver is only active during the Shift-IR and Shift-DR TAP controller states. In all other states, the TDO ball is in a High-Z state. The output changes on the falling edge of TCK. TDO is connected to the least significant bit (LSB) of any register (see Figure 70 (page 112)).

TAP Controller

The TAP controller is a finite state machine that uses the state of the TMS ball at the rising edge of TCK to navigate through its various modes of operation (see Figure 69 (page 112)). Each state is described in detail below.

Test-Logic-Reset

The test-logic-reset controller state is entered when TMS is held HIGH for at least five consecutive rising edges of TCK. As long as TMS remains HIGH, the TAP controller will remain in the test-logic-reset state. The test logic is inactive during this state.

Run-Test/Idle

The run-test/idle is a controller state in between scan operations. This state can be maintained by holding TMS LOW. From there, either the data register scan, or subsequently, the instruction register scan, can be selected.

Select-DR-Scan

Select-DR-scan is a temporary controller state. All test data registers retain their previous state while here.

Capture-DR

The capture-DR state is where the data is parallel-loaded into the test data registers. If the boundary-scan register is the currently selected register, then the data currently on the balls is latched into the test data registers.

Shift-DR

Data is shifted serially through the data register while in this state. As new data is input through the TDI ball, data is shifted out of the TDO ball.

Exit1-DR, Pause-DR, and Exit2-DR

The purpose of exit1-DR is used to provide a path to return back to the run-test/idle state (through the update-DR state). The pause-DR state is entered when the shifting of data through the test registers needs to be suspended. When shifting is to reconvene, the controller enters the exit2-DR state and then can re-enter the shift-DR state.

Update-DR

When the EXTEST instruction is selected, there are latched parallel outputs of the boundary-scan shift register that only change state during the update-DR controller state.

Instruction Register States

The instruction register states of the TAP controller are similar to the data register states. The desired instruction is serially shifted into the instruction register during the shift-IR state and is loaded during the update-IR state.

Figure 69: TAP Controller State Diagram



Figure 70: TAP Controller Functional Block Diagram



Note: 1. x = Die Rev. A = 121 for all configurations, Die Rev. B = 135 for all configurations.

Performing a TAP RESET

A reset is performed by forcing TMS HIGH (V_{DDQ}) for five rising edges of t_{CK} . This RESET does not affect the operation of the device and may be performed while the device is operating.

At power-up, the TAP is reset internally to ensure that TDO comes up in a High-Z state. If JTAG inputs cannot be guaranteed to be stable during power-up it is recommended that TMS be held HIGH for at least 5 consecutive TCK cycles prior to boundary scan testing.

TAP Registers

Registers are connected between the TDI and TDO balls and allow data to be scanned into and out of the RLD RAM 3 device test circuitry. Only one register can be selected at a time through the instruction register. Data is serially loaded into the TDI ball on the rising edge of TCK. Data is output on the TDO ball on the falling edge of TCK.

Instruction Register

Eight-bit instructions can be serially loaded into the instruction register. This register is loaded during the update-IR state of the TAP controller. Upon power-up, the instruction register is loaded with the IDCODE instruction. It is also loaded with the IDCODE instruction if the controller is placed in a reset state as described in the previous section.

When the TAP controller is in the capture-IR state, the two LSBs are loaded with a binary 01 pattern to allow for fault isolation of the board-level serial test data path.

Bypass Register

To save time when serially shifting data through registers, it is sometimes advantageous to skip certain chips. The bypass register is a single-bit register that can be placed between the TDI and TDO balls. This enables data to be shifted through the device with minimal delay. The bypass register is set LOW (V_{SS}) when the BYPASS instruction is executed.

Boundary-Scan Register

The boundary-scan register is connected to all the input and bidirectional balls on the device. Several balls are also included in the scan register to reserved balls. Die Revision A has a 121-bit register. Die Revision B has a 135-bit register.

The boundary-scan register is loaded with the contents of the RAM I/O ring when the TAP controller is in the capture-DR state and is then placed between the TDI and TDO balls when the controller is moved to the shift-DR state.

The order in which the bits are connected for Die Revision A are shown in Table 52 (page 118) and the order in which the bits are connected for Die Revision B are shown in Table 53 (page 120). Each bit corresponds to one of the balls on the RLD RAM package. The MSB of the register is connected to TDI, and the LSB is connected to TDO.

Identification (ID) Register

The ID register is loaded with a vendor-specific, 32-bit code during the capture-DR state when the IDCODE command is loaded in the instruction register. The IDCODE is hardwired into the RLD RAM 3 and can be shifted out when the TAP controller is in the shift-DR state. The ID register has a vendor code and other information described in Table 49 (page 117).

TAP Instruction Set

Overview

There are 2^8 different instructions possible with the 8-bit instruction register. All combinations used are listed in Table 51 (page 118). These six instructions are described in detail below. The remaining instructions are reserved and should not be used.

The TAP controller used in this RLD RAM 3 device is fully compliant to the IEEE 1149.1 convention.

Instructions are loaded into the TAP controller during the shift-IR state when the instruction register is placed between TDI and TDO. During this state, instructions are shifted through the instruction register through the TDI and TDO balls. To execute the instruction after it is shifted in, the TAP controller needs to be moved into the update-IR state.

EXTEST

The EXTEST instruction enables circuitry external to the component package to be tested. Boundary-scan register cells at output balls are used to apply a test vector, while those at input balls capture test results. Typically, the first test vector to be applied using the EXTEST instruction will be shifted into the boundary-scan register using the PRELOAD instruction. Thus, during the update-IR state of EXTEST, the output driver is turned on, and the PRELOAD data is driven onto the output balls.

IDCODE

The IDCODE instruction causes a vendor-specific, 32-bit code to be loaded into the instruction register. It also places the instruction register between the TDI and TDO balls and enables the IDCODE to be shifted out of the device when the TAP controller enters the shift-DR state. The IDCODE instruction is loaded into the instruction register upon power-up or whenever the TAP controller is given a test logic reset state.

High-Z

The High-Z instruction causes the bypass register to be connected between the TDI and TDO. This places all RLD RAM outputs into a High-Z state.

CLAMP

When the CLAMP instruction is loaded into the instruction register, the data driven by the output balls are determined from the values held in the boundary-scan register.

SAMPLE/PRELOAD

When the SAMPLE/PRELOAD instruction is loaded into the instruction register and the TAP controller is in the capture-DR state, a snapshot can be taken of the states of the component's input and output signals without interfering with the normal operation of the assembled board. The snapshot is taken on the rising edge of TCK and is captured in the boundary-scan register. The data can then be viewed by shifting through the component's TDO output.

The user must be aware that the TAP controller clock can only operate at a frequency up to 50 MHz, while the RLD RAM 3 clock operates significantly faster. Because there is a large difference between the clock frequencies, it is possible that during the capture-DR state, an input or output will undergo a transition. The TAP may then try to capture a signal while in transition (metastable state). This will not harm the device, but there is

no guarantee as to the value that will be captured. Repeatable results may not be possible.

To ensure that the boundary-scan register will capture the correct value of a signal, the RLD RAM signal must be stabilized long enough to meet the TAP controller's capture setup plus hold time (t_{CS} plus t_{CH}). The RLD RAM clock input might not be captured correctly if there is no way in a design to stop (or slow) the clock during a SAMPLE/PRELOAD instruction. If this is an issue, it is still possible to capture all other signals and simply ignore the value of the CK and CK# captured in the boundary-scan register.

After the data is captured, it is possible to shift out the data by putting the TAP into the shift-DR state. This places the boundary-scan register between the TDI and TDO balls.

BYPASS

When the BYPASS instruction is loaded in the instruction register and the TAP is placed in a shift-DR state, the bypass register is placed between TDI and TDO. The advantage of the BYPASS instruction is that it shortens the boundary-scan path when multiple devices are connected together on a board.

Reserved for Future Use

The remaining instructions are not implemented but are reserved for future use. Do not use these instructions.

Figure 71: JTAG Operation - Loading Instruction Code and Shifting Out Data



Figure 72: TAP Timing



Table 46: TAP Input AC Logic Levels

$0^{\circ}\text{C} \leq T_C \leq +95^{\circ}\text{C}$; $+1.28\text{V} \leq V_{DD} \leq +1.42\text{V}$, unless otherwise noted

Description	Symbol	Min	Max	Units
Input HIGH (logic 1) voltage	V_{IH}	$V_{REF} + 0.225$	-	V
Input LOW (logic 0) voltage	V_{IL}	-	$V_{REF} - 0.225$	V

Note: 1. All voltages referenced to V_{SS} (GND).

Table 47: TAP AC Electrical Characteristics

$0^{\circ}\text{C} \leq T_C \leq +95^{\circ}\text{C}$; $+1.28\text{V} \leq V_{DD} \leq +1.42\text{V}$

Description	Symbol	Min	Max	Units
Clock				
Clock cycle time	t_{THTH}	20		ns
Clock frequency	f_{TF}		50	MHz
Clock HIGH time	t_{THTL}	10		ns
Clock LOW time	t_{TLTH}	10		ns
TDI/TDO times				
TCK LOW to TDO unknown	t_{TLOX}	0		ns
TCK LOW to TDO valid	t_{TLOV}		10	ns
TDI valid to TCK HIGH	t_{DVTH}	5		ns
TCK HIGH to TDI invalid	t_{THDX}	5		ns
Setup times				
TMS setup	t_{MVT}	5		ns

Table 47: TAP AC Electrical Characteristics (Continued)
 $0^{\circ}\text{C} \leq T_C \leq +95^{\circ}\text{C}; +1.28\text{V} \leq V_{DD} \leq +1.42\text{V}$

Description	Symbol	Min	Max	Units
Capture setup	t^{CS}	5		ns
Hold times				
TMS hold	t^{THMX}	5		ns
Capture hold	t^{CH}	5		ns

Note: 1. t^{CS} and t^{CH} refer to the setup and hold time requirements of latching data from the boundary-scan register.

Table 48: TAP DC Electrical Characteristics and Operating Conditions
 $0^{\circ}\text{C} \leq T_C \leq +95^{\circ}\text{C}; +1.28\text{V} \leq V_{DD} \leq +1.42\text{V}$, unless otherwise noted

Description	Condition	Symbol	Min	Max	Units	Notes
Input HIGH (logic 1) voltage		V_{IH}	$V_{REF} + 0.15$	V_{DDQ}	V	1, 2
Input LOW (logic 0) voltage		V_{IL}	V_{SSQ}	$V_{REF} - 0.15$	V	1, 2
Input leakage current	$0\text{V} \leq V_{IN} \leq V_{DD}$	I_{LI}	-5.0	5.0	μA	
Output leakage current	Output disabled, $0\text{V} \leq V_{IN} \leq V_{DDQ}$	I_{LO}	-5.0	5.0	μA	
Output low voltage	$I_{OLC} = 100\mu\text{A}$	V_{OL1}		0.2	V	1
Output low voltage	$I_{OLT} = 2\text{mA}$	V_{OL2}		0.4	V	1
Output high voltage	$ I_{OHC} = 100\mu\text{A}$	V_{OH1}	$V_{DDQ} - 0.2$		V	1
OUTPUT HIGH VOLTAGE	$ I_{OHT} = 2\text{mA}$	V_{OH2}	$V_{DDQ} - 0.4$		V	1

Notes: 1. All voltages referenced to V_{SS} (GND).
 2. See AC Overshoot/Undershoot Specifications section for overshoot and undershoot limits.

Table 49: Identification Register Definitions

Instruction Field	All Devices	Description
Revision number (31:28)	abcd	ab = 00 for Die Revision A, 01 for Die Revision B cd = 00 for x18, 01 for x36
Device ID (27:12)	00jkiddef10100111	def = 000 for 576Mb, 001 for 1Gb Double Die Package, 010 for 1Gb Monolithic i = 0 for common I/O jk = 10 for RLD RAM 3
Micron JEDEC ID code (11:1)	00000101100	Enables unique identification of RLD RAM vendor
ID register presence indicator (0)	1	Indicates the presence of an ID register

Table 50: Scan Register Sizes

Register Name	Bit Size
Instruction	8
Bypass	1
ID	32
Boundary scan (Die Revision A)	121
Boundary scan (Die Revision B)	135

Table 51: Instruction Codes

Instruction	Code	Description
Extest	0000 0000	Captures I/O ring contents; Places the boundary-scan register between TDI and TDO; This operation does not affect RLD RAM 3 operations.
ID code	0010 0001	Loads the ID register with the vendor ID code and places the register between TDI and TDO; This operation does not affect RLD RAM 3 operations.
Sample/preload	0000 0101	Captures I/O ring contents; Places the boundary-scan register between TDI and TDO.
Clamp	0000 0111	Selects the bypass register to be connected between TDI and TDO; Data driven by output balls are determined from values held in the boundary-scan register.
High-Z	0000 0011	Selects the bypass register to be connected between TDI and TDO; All outputs are forced into High-Z.
Bypass	1111 1111	Places the bypass register between TDI and TDO; This operation does not affect RLD RAM operations.

Table 52: Boundary Scan (Exit), Die Rev. A

Bit#	Ball	Bit#	Ball	Bit#	Ball
1	N8	42	L7	83	M3
2	N8	43	K7	84	M3
3	M11	44	H1	85	M5
4	M11	45	H4	86	M5
5	M9	46	G2	87	L2
6	M9	47	G3	88	L2
7	L12	48	F1	89	L4
8	L12	49	F5	90	L4
9	L10	50	F4	91	L6
10	L10	51	F2	92	L6
11	L8	52	D1	93	K1
12	L8	53	F7	94	K1
13	K13	54	D7	95	K3
14	K13	55	C7	96	K3
15	K11	56	A13	97	J4



Table 52: Boundary Scan (Exit), Die Rev. A (Continued)

Bit#	Ball	Bit#	Ball	Bit#	Ball
16	K11	57	B7	98	J4
17	J10	58	E7	99	J6
18	J10	59	D13	100	K5
19	J8	60	F12	101	J2
20	K9	61	F10	102	A4
21	J12	62	F9	103	A4
22	A10	63	E2	104	A6
23	A10	64	E12	105	A6
24	A8	65	F6	106	B3
25	A8	66	F8	107	B3
26	B11	67	G7	108	B5
27	B11	68	H7	109	B5
28	B9	69	G5	110	C2
29	B9	70	G9	111	C2
30	C12	71	H6	112	C4
31	C12	72	H8	113	C4
32	C10	73	F13	114	C6
33	C10	74	G11	115	C6
34	C8	75	G12	116	E4
35	C8	76	H10	117	E4
36	E10	77	H3	118	D3
37	E10	78	H11	119	D3
38	D11	79	H13	120	E6
39	D11	80	M7	121	D5
40	E8	81	N6	-	-
41	D9	82	N6	-	-



Table 53: Boundary Scan (Exit), Die Rev. B

Bit#	Ball	Bit#	Ball	Bit#	Ball
1	N8	46	D9	91	N6
2	N8	47	L7	92	M3
3	M11	48	K7	93	M3
4	M11	49	H1	94	M5
5	M9	50	H3	95	M5
6	M9	51	H4	96	L2
7	L12	52	G2	97	L2
8	L12	53	G3	98	L4
9	L10	54	F1	99	L4
10	L10	55	H6	100	L6
11	L8	56	G5	101	L6
12	L8	57	G4	102	K1
13	K13	58	G1	103	K1
14	K13	59	F6	104	K3
15	K11	60	E2	105	K3
16	K11	61	F5	106	J4
17	J10	62	F4	107	J4
18	J10	63	F2	108	J6
19	J8	64	D1	109	J6
20	J8	65	F7	110	K5
21	K9	66	D7	111	K5
22	K9	67	C7	112	J2
23	J12	68	A13	113	J2
24	J12	69	B7	114	A4
25	A10	70	E7	115	A4
26	A10	71	D13	116	A6
27	A8	72	F12	117	A6
28	A8	73	F10	118	B3
29	B11	74	F9	119	B3
30	B11	75	E12	120	B5
31	B9	76	G13	121	B5
32	B9	77	G10	122	C2
33	C12	78	F8	123	C2
34	C12	79	G7	124	C4
35	C10	80	H7	125	C4
36	C10	81	G9	126	C6
37	C8	82	H8	127	C6
38	C8	83	F13	128	E4



Table 53: Boundary Scan (Exit), Die Rev. B (Continued)

Bit#	Ball	Bit#	Ball	Bit#	Ball
39	E10	84	G11	129	E4
40	E10	85	G12	130	D3
41	D11	86	H10	131	D3
42	D11	87	H11	132	E6
43	E8	88	H13	133	E6
44	E8	89	M7	134	D5
45	D9	90	N6	135	D5

8000 S. Federal Way, P.O. Box 6, Boise, ID 83707-0006, Tel: 208-368-4000
www.micron.com/products/support Sales inquiries: 800-932-4992
Micron and the Micron logo are trademarks of Micron Technology, Inc.
All other trademarks are the property of their respective owners.

This data sheet contains minimum and maximum limits specified over the power supply and temperature range set forth herein. Although considered final, these specifications are subject to change, as further product development and data characterization sometimes occur.



Стандарт Электрон Связь

Мы молодая и активно развивающаяся компания в области поставок электронных компонентов. Мы поставляем электронные компоненты отечественного и импортного производства напрямую от производителей и с крупнейших складов мира.

Благодаря сотрудничеству с мировыми поставщиками мы осуществляем комплексные и плановые поставки широчайшего спектра электронных компонентов.

Собственная эффективная логистика и склад в обеспечивает надежную поставку продукции в точно указанные сроки по всей России.

Мы осуществляем техническую поддержку нашим клиентам и предпродажную проверку качества продукции. На все поставляемые продукты мы предоставляем гарантию .

Осуществляем поставки продукции под контролем ВП МО РФ на предприятия военно-промышленного комплекса России , а также работаем в рамках 275 ФЗ с открытием отдельных счетов в уполномоченном банке. Система менеджмента качества компании соответствует требованиям ГОСТ ISO 9001.

Минимальные сроки поставки, гибкие цены, неограниченный ассортимент и индивидуальный подход к клиентам являются основой для выстраивания долгосрочного и эффективного сотрудничества с предприятиями радиоэлектронной промышленности, предприятиями ВПК и научно-исследовательскими институтами России.

С нами вы становитесь еще успешнее!

Наши контакты:

Телефон: +7 812 627 14 35

Электронная почта: sales@st-electron.ru

Адрес: 198099, Санкт-Петербург,
Промышленная ул, дом № 19, литера Н,
помещение 100-Н Офис 331