



## ABOUT REDINGTON

Since 1961 REDINGTON has offered products that have proven to be rugged and manufactured to the highest quality standards. Over several decades we have focused on bringing our customers quality products at competitive prices. This catalog contains several new and innovative products confirming our commitment to provide state-of-the-art solutions for our customers.

Over the past few years, we have committed to developing the capabilities to provide the finest electronic solutions for our customers' counting, elapsed time indicating and controlling needs. We have done this while continuing to supply and support our broad range of rugged mechanical and electromechanical products. We stand ready to work with our customers to provide cost effective solutions and to match the best technology with your applications.

## CUSTOMER SERVICE

We are committed to providing the best customer service anywhere. We strive to provide our customers with prompt replies, on time delivery and hassle free customer satisfaction. Our goals are to serve our customers and take the extra steps necessary to satisfy your requirements.

We provide field assistance backed up by competent technical support from our headquarters location. We have Authorized Distributors and Representatives throughout North America that stand ready to assist our customers. Contact your local Sales Representative, or call us at the factory, to get the name of your nearest authorized distributor.

### How to Contact Us

on the web...



web site: [www.redingtoncounters.com](http://www.redingtoncounters.com)  
e-mail: [info@redingtoncounters.com](mailto:info@redingtoncounters.com)

REDINGTON COUNTERS, INC.  
P.O. Box 608  
130 Addison Road  
Windsor, CT 06095



by Mail...

### Customer Service/Application Assistance

by Phone...



(800) 395-7337  
(860) 688-6205

by Fax...



Fax: (860) 688-1591



<b>Introduction</b>		Page#
		4

## COUNTERS

### Electronic

<b>Model 33</b>	LCD 8 digits, self powered	8
<b>NEW! Model 3302</b>	LCD Large 4 digit display PCB Mount, self powered	10
<b>Model 52</b>	LCD 8 digits, uni or bi-directional	11
<b>Model 53</b>	LCD 7 or 8 digits, self powered, AC, DC or switch input	13
<b>Model 54</b>	LCD 7 or 8 digits, PCB module, self-powered	15
<b>Model 55</b>	7 digits, 3 mountings, AC/DC, EEPROM, reset	52
<b>Model 56</b>	7 digits, 3 mountings, AC/DC, EEPROM, reset, "Alerts"	55
<b>Model 57</b>	7 digits, 3 mountings, DC, EEPROM, reset, multi-function, 1 or 2 displays	58
<b>Model 59</b>	7 digits, PCB mount, DC, EEPROM, reset, multi-function	61
<b>Model 88</b>	LCD 8 digits, EEPROM, multifunction, uni or bi- directional	85
<b>Model 94</b>	LCD 6 digits, 3 mountings, reset, large figures	16

### Electromechanical

<b>Model 10</b>	General-purpose totalizer, 6 figures, versatile mountings	19
<b>Model 10</b>	General-purpose totalizer, 7 figures, versatile mountings	20
<b>Model 40</b>	Low cost, 6 or 7 figures, non-reset	21
<b>Model 44</b>	6 figures, non-reset	23
<b>Model 48</b>	Compact 6 or 7 figures, non-reset	24
<b>Model 49</b>	4 or 6 figures, push-button reset	26
<b>Model 128</b>	4 figures, rotary reset, panel or base mount	28
<b>Model 300</b>	6 figures, panel mount, push-button reset	29

### Mechanical

<b>Model 08</b>	Rotary counter	30
<b>Model 14</b>	Small, rotary or stroke counter	31
<b>Model 20</b>	Medium duty, stroke counter	35
<b>Model 22</b>	Medium duty, rotary counter	36
<b>Model 27</b>	Heavy-duty, stroke counter, 5 figures	37
<b>Model 28</b>	Heavy-duty, stroke counter, 5 figures	38
<b>Model 29</b>	Heavy-duty, stroke counter, 6 figures	39
<b>Model 29</b>	Heavy-duty, rotary counter, 6 figures	40
<b>Model 41</b>	Combined register and totalizer, 3 or 4 figures	41
<b>Model 46</b>	Compact, 5 figure, stroke counter	42
<b>Model 750</b>	Rugged revolution counter	43
<b>Model PCU</b>	Stroke counter, 3 or 4 figures	44

### Hand Tally Counters

<b>Model 18</b>	Hand Tally counters	33
<b>Model 19</b>	Modular Tally counters	34
<b>NEW! Model 46T</b>	Compact stroke counter with thumb lever, 5 figures	42
<b>Model E1</b>	LCD Hand Tally, 4 digits, self powered	17
<b>NEW! Model E2/E3</b>	LCD ADD and ADD/SUBTRACT 4 digit Hand Tally	18

## PREDETERMINING COUNTERS

### Electronic

<b>Model 83</b>	LCD 6 digits, 1/16 DIN, preset & batch counter, EEPROM, AC/DC	89
<b>Model 88</b>	LCD 8 digits, serial communications, EEPROM, AC/DC, analog I/O	85

### Electromechanical

<b>Model 58</b>	4 or 6 figures, panel mount, SPDT switch	45
-----------------	--	----



## HOUR METERS

### Electronic

<b>Model 33</b>	6 digits, totally sealed, 4 mounting, AC/DC inputs	46
<b>Model 51</b>	6 digits, totally sealed, 3 mountings, AC/DC/Inductive, "Alerts", Tach.	48
<b>Model 53</b>	7 digits, LCD, self powered, AC, DC or switch input	50
<b>Model 55</b>	7 digits, 3 mountings, AC/DC, EEPROM, reset	52
<b>Model 56</b>	7 digits, 3 mountings, AC/DC, EEPROM, reset, "Alerts"	55
<b>Model 57</b>	7 digits, 3 mountings, DC, EEPROM, reset, multi-function, 1 or 2 displays	58
<b>Model 59</b>	7 digits, PCB mount, DC, EEPROM, reset, multi-function	61
<b>Model 88</b>	6 digits, panel mount, Hrs, Min., Sec., serial communications, EEPROM	87
<b>Model 94</b>	6 digits, 3 mountings, reset, large figures	63
<b>NEW! Model 720</b>	7 digits, rugged steel housing	64

### Electromechanical

<b>Model 77</b>	6 figures, non-reset, panel mount	65
<b>Model 710</b>	5 figures reset, 6 figure non-reset, AC voltage, 3-Hole mount	66
<b>Model 711/731</b>	7 figures, non-reset, AC/DC voltages	67
<b>Model 711/731</b>	7 figures, non-reset, AC/DC voltages, distinctive styling	69
<b>Model 711</b>	6 or 7 figures, reset or non-reset, AC voltage, rectangular styling	70
<b>Model 720</b>	5 or 6 figures, rugged steel housing, designed to mil-spec.	71
<b>NEW! Model 722</b>	6 figures, totally sealed AC Hour Meter, 115/230VAC, 50/60Hz	72
<b>NEW! Model 732</b>	6 figures, totally sealed DC Hour Meter, 10-80 VDC	74

## PREDETERMINING TIMERS

### Electronic

<b>Model 83</b>	6 digits, 1/16 DIN, EEPROM, serial communications	94
<b>Model 88</b>	8 digits, EEPROM, serial communications	85

## CONTROLLERS & INDICATORS

### Electronic

<b>Model 53</b>	Tachometer, 4 digits, LCD, self powered, AC/DC inputs	76
<b>Model 85</b>	4 digits, 1/8 DIN, RED or Green display, input scaling, EEPROM	78
<b>Model 88</b>	8 digits, panel mount, serial communications, input scaling, EEPROM	85
<b>Model 92</b>	Hand Held Tachometer/LCD, rotary and linear speed indicator	98

## DIGITAL PANEL METERS

### Electronic

<b>Model 85</b>	3 1/2 digits, 1/8 DIN, temperature, rate, freq., volts, amps, ohms, modular	78
-----------------	---	----

## ENCODERS/SENSORS

<b>Model 65</b>	Incremental optical encoder, uni or bi-directional	100
<b>Model 65</b>	Proximity switch, DC voltage, for counting or rate input	101

## APPENDICES

Glossary of terms	102
Part# Index	106



### TOTALIZING COUNTERS

Totalizing counters are used to sum the total number of cycles or inputs to a device. These counters have no "outputs". Totalizers can be Mechanical, Electromechanical or Electronic.

Totalizers are typically used to total cycle count, piece count, and linear length or to indicate position. Displays for Mechanical & Electromechanical Totalizers are molded figure wheels usually displaying 0-9 digits on a contrasting background and have a count capacity of 3-8 figures.

### Mechanical Totalizers

The input for Mechanical Totalizers can be Rotary, Stroke or Rotary Ratchet. Mechanical Totalizers require no operating power or sensor and are easy to install. For hand operated applications you need to consider our Model 18, Model 19 or Model 46 with thumb lever option.

**SHAFT ROTATIONS:** Arrows indicate shaft rotation to increase count.

**Left-hand top-coming:**  
(rotation #1)

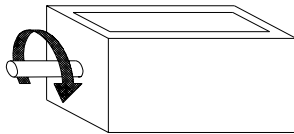

**Left-hand top-going:**  
(rotation #2)

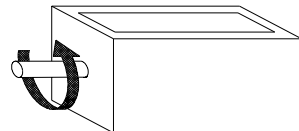

**Right-hand top-coming:**  
(rotation #3)

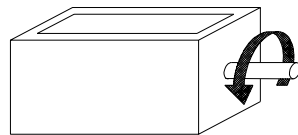

**Right-hand top-going:**  
(rotation #4)

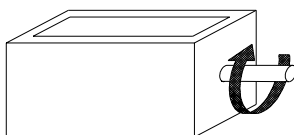

### Basic operation of a mechanical stroke counter

The illustration below shows the lever in the rest position with a total shaft rotation of X+Y+Z. Although these angles may differ from model to model, the total shaft rotation contains a pre-travel (X), a count stroke (Y), and an over-travel (Z). The lever must start in the pre-travel area and continue through to the over-travel area to register a count. It is recommended that the spring furnished with the counter be used to simplify adjustment of count stroke to drive mechanism.

**Note:** This illustrates rotations 2 and 3 only.

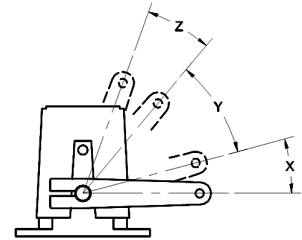

### Typical Applications

Punchpress

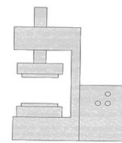

Gaming



Inventory



Printing Press

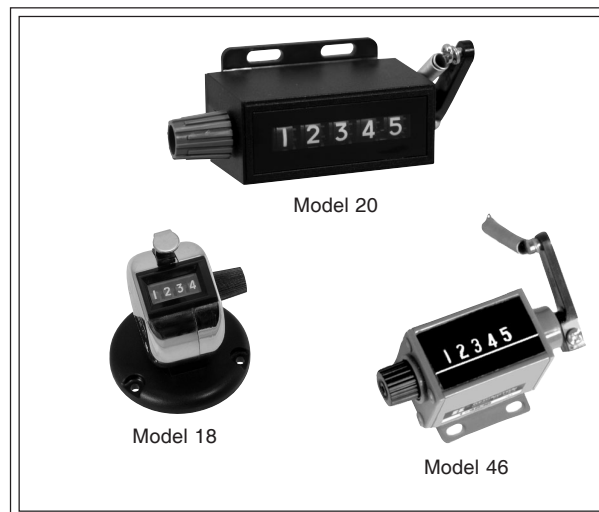
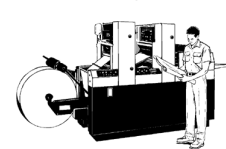



### Electromechanical Totalizers

These count on AC or DC voltage input signals. Electro-mechanical Totalizers are often used when it is desirable to mount the totalizer in a “remote” location. The input can be from a variety of sensors including a Proximity switch, Photoelectric or Mechanical switch. Several choices are available for mounting, reset and add-subtract counting.

#### Typical Applications

Printing Press

Photocopiers

Gaming Machines

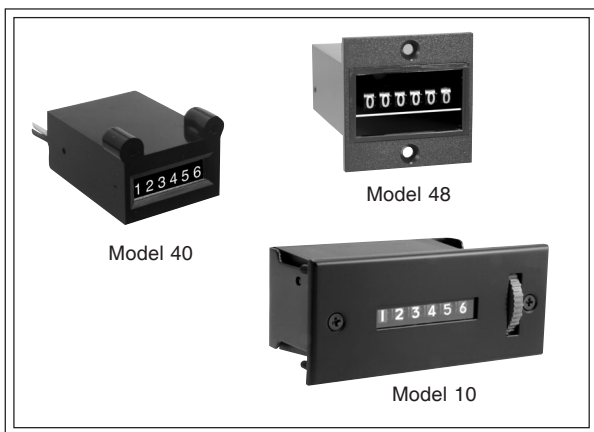
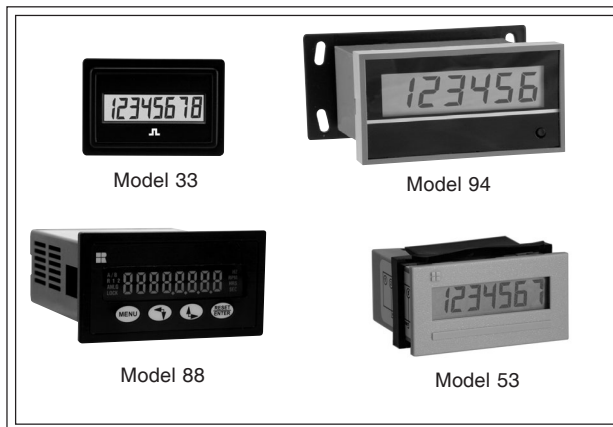
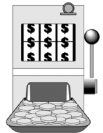
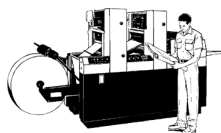

### Electronic Totalizers

Electronic Totalizers utilize LED's or LCD's as displays with a variety of colors and digits sizes. The count capacity can be up to 8 digits with leading “0” suppression. Electronic Totalizers provide the user with several advantages over Mechanical or Electromechanical Totalizers. Electronic Totalizers are silent, have high- speed count/input capability, interface easily with a variety of sensors, have communications, programmable decimal points, input scaling and quadrature inputs.

#### Typical Applications

Office Equipment

Control Panels

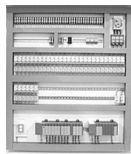

Injection Molding

Test Equipment



### PREDETERMINING COUNTERS/TIMERS

Predetermining counters can provide the user with an output signal when a preset number is reached. Typical applications are controlling batch or lot size, positioning, punching, converting or cut-to-length.

#### Electromechanical Predetermining Counters

Electromechanical predetermining counters are easy to preset and apply. They are ideal for slow batch counting and remote locations. They are limited on their count speed and do not have automatic reset capability. The input signal is an AC/DC voltage source and can come from switch or relay contacts, photoelectric control or proximity switch.

#### Typical Applications

Process Control

Batch Control

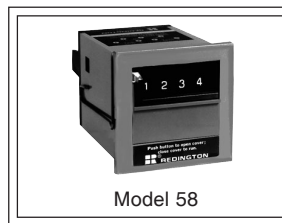
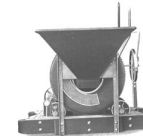
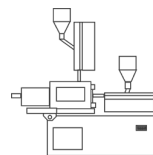

#### Electronic Predetermining Counters/Timers

They provide an output signal, relay contacts or solid state, when a preset number is reached. They can be used for cut-to length, batch or cycle counting, punching and positioning. They can also interface with most sensors including Encoders, Proximity switches and Photoelectric controls. Some models are available with an analog input and output.



They feature high speeds, silent operation, instant reset, without loss of incoming counts, bi-directional count capability, data communications, LED or LCD displays, programmable decimal points and input scaling.

Typical Applications

Cut-to-Length

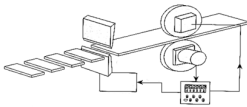

Batching

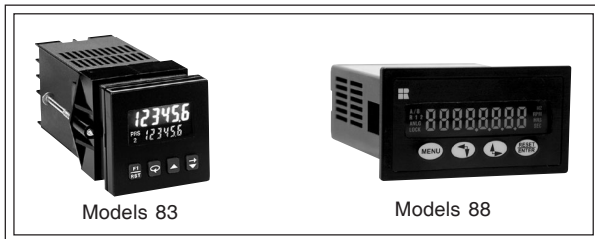

RATE INDICATORS AND CONTROLLERS

Rate Indicators and Controllers can be used to monitor or measure frequency or RPM. Hand Held Tachometers are available to measure RPM or Linear speed. Panel mount indicators/controllers can display and control High-Low set-point limits and provide an output signal for controlling.

Typical Applications

Flow Level and Control

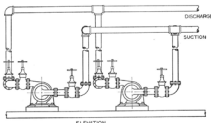

Temperature

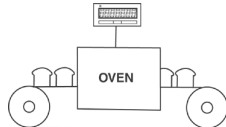

Hand-Held Tachometer

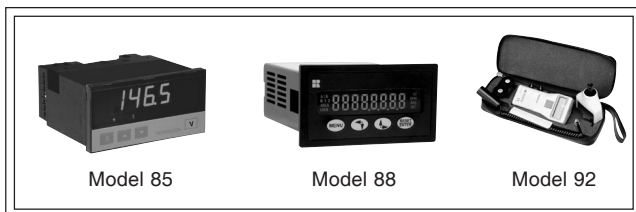
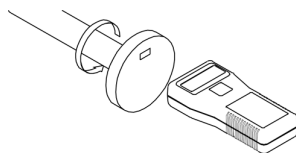

DIGITAL PANEL METERS

Digital Panel Meters can be used to solve a wide range of applications. These include, Indication or Controlling, Volts, Current, Ohms, Temperature, Frequency and RPM. The Redington Model 85 is modular and the main housing, with modules, can be utilized to solve all of the applications below. The Model 85 has "plug-in" modules, which can be configured to the users needs or specifications. The 1/8 DIN enclosure is rated for IP65 and is available with a RED or GREEN LED display.

Typical Applications

Temperature

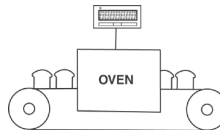

Volts/Amps

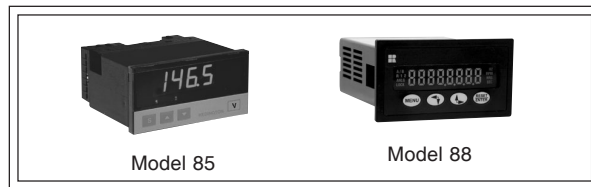

HOUR/MAINTENANCE METERS

Hour/Maintenance Meters are used to record "running" hours for preventive maintenance or warranty purposes. There are several mounting variations available, 2-Hole rectangular, flush-round, flush rectangular, 3-Hole round and PCB Modules. Other models are available for mounting by a DIN rail kit. A wide range of voltages, AC DC or Inductive, makes the Meters adaptable to almost any application. Most Hour Meters are available with 6-7 figures or digits. "Redi-Alert" maintenance alarms can be programmed into the Electronic meters. When the maintenance is due the display will flash off - on and can provide an electrical output by relay or solid- state circuit. Some Meters can record Hour & Counts in the same model.

Electromechanical Hour Meters

Totally sealed Models are provided for harsh environments that conform to SAE J1378 specifications. Models are available with 6-7 figures on a contrasting background. Manual-reset, remote reset and non-reset models provide a wide choice of options. Most models are agency approved, UL/cUL/CSA recognized and CE compliant. This technology is time tested and has proven to be ultra reliable.



### Typical Applications

Test Equipment



Control Panel

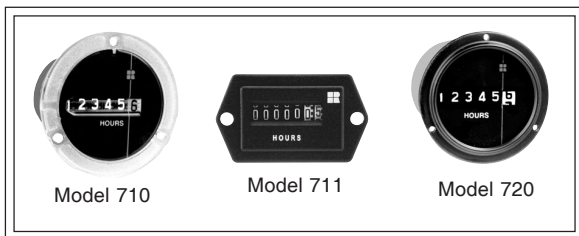
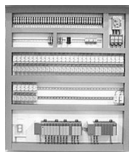

### Electronic Hour Meters (LCD)

The standard mountings for the industry are available. These products are microprocessor based and can be specifically programmed for an application. Models are available with Redi-Alerts, electrical outputs, tachometers, battery operation, or EEPROM memory. Models are also available with an Hour Meter and Counter in the same meter. Totally sealed models conform to SAE-1378 and NEMA 4X specifications.

### Typical Applications

Construction Equipment



Generators

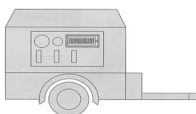

Medical Equipment

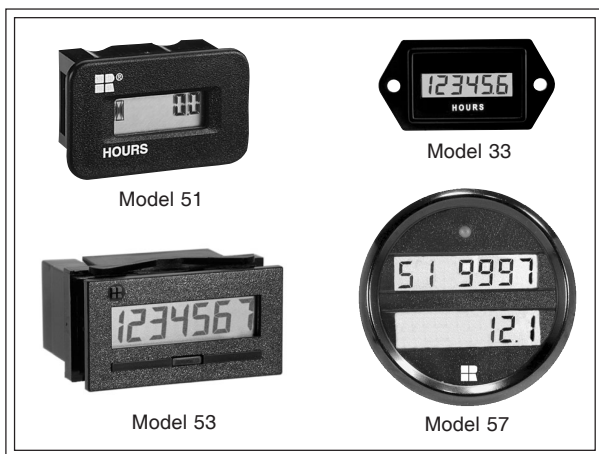



Description

The Redington Model 33 line of LCD counters provides a large display, 7mm high figures, in an eight digit counter. The counters are available in a variety of mountings: 2-hole rectangular, 3-hole round, flush-round and flush-rectangular. Voltage operating ranges are 10-277 VDC AND 20-277VAC. All models are totally sealed from moisture and dirt and conform to NEMA 4 & 4X specifications when mounted with the optional gasket. Their rugged construction makes them ideal replacements for current electromechanical counters. Units have polarized LCD for high visibility in sunlight.

Features

- AC or DC voltage input in the same unit
- Totally sealed from moisture and dirt
- Always on display
- Compact depth
- Clip retainer mount or screws (supplied)

Options

- Custom logos and bezels
- Terminations
- Remote reset - dry contact with 6" wire leads
- Gaskets
  - 5003-002S gasket for 2-hole mount
  - 5003-003S gasket for flush-rectangular mount
  - 5003-004S gasket for flush-round mount
  - 5003-005S gasket for 3-hole round mount

Specifications

<b>Display:</b>	LCD with large 0.28" [7mm] high figures, black on light background	<b>Humidity:</b>	95% SAE J1378
<b>Records &amp; Displays:</b>	8 digit (99999999)	<b>Operating Temperature:</b>	-40°F to +185°F [-40°C to +85°C]
<b>Inputs:</b>	10 to 277VDC AND 20-277VAC Vih* 20VAC or 10VDC minimum Vil* 3VAC or 3VDC maximum	<b>Sealing:</b>	Totally sealed, panel gaskets-NEMA 4 & 4X
<b>Speed:</b>	25 counts per second	<b>Agency Approvals:</b>	CE compliant UL/cUL recognized (file# ELIY2.E36690)
<b>Battery Life:</b>	7+ years	<b>Termination:</b>	0.250" [6.4mm] spades
<b>Shock:</b>	44 to 55g's, SAE J1378	<b>Reset:</b>	Optional - dry contact with 6" wire leads
<b>Vibration:</b>	20 g @ 10 to 80 Hz, SAE J1378	<b>Case Material:</b>	Polymer (black)
		<b>Weight:</b>	1oz [28g]

\* Vih is the input high voltage. This is specified as the minimum input voltage that the Model 33 will recognize as a high level. Vil is the input low voltage. This is specified as the maximum input voltage that the Model 33 will recognize as a low level.

Note: When interfacing the Model 33 with a Solid State Relay or AC Sensor, the leakage current needs to be considered. Contact the factory or see the application note at www.redingtoncounters.com for further information.

Models	Description	Models	Description
3301-0000	2-Hole Rect., 10-277 VDC AND 20-277VAC	3301-0010	2-Hole Rect., 10-277 VDC AND 20-277VAC, remote reset
3301-1000	3-Hole Round, 10-277 VDC AND 20-277VAC	3301-1010	3-Hole Round, 10-277 VDC AND 20-277VAC, remote reset
3301-2000	Flush-Rect., 10-277 VDC AND 20-277VAC	3301-2010	Flush-Rect., 10-277 VDC AND 20-277VAC, remote reset
3301-3000	Flush-Round, 10-277 VDC AND 20-277VAC	3301-3010	Flush-Round, 10-277 VDC AND 20-277VAC, remote reset

\* All Items are normally in factory stock.





Dimensions

2-Hole

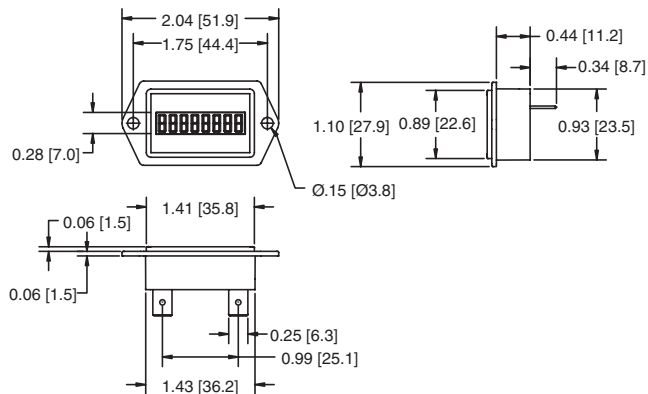

In-front panel cutout: 1.45 X 0.95 [24.0 x 37.0]  
Behind panel cutout: 1.42 X 0.90 [22.9 x 36.1]

3-Hole Round

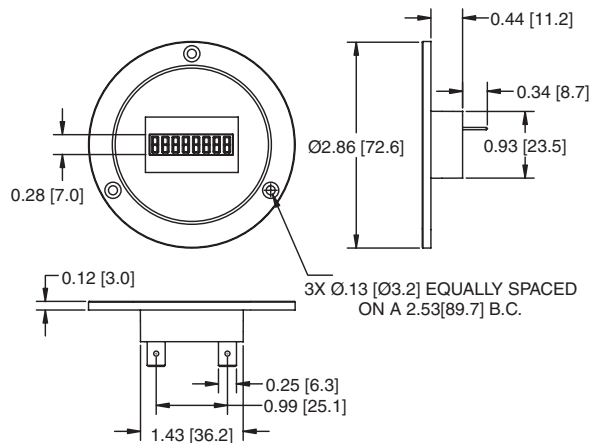

Panel cutout: 1.45 X 0.95 [24.0 x 37.0]

Flush-Round

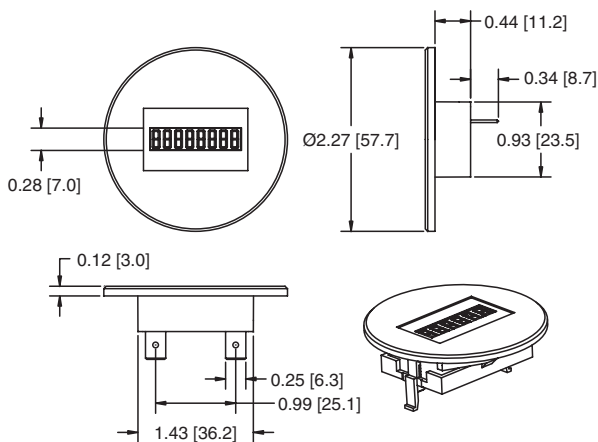

Panel cutout: 1.45 X 0.95 [24.0 x 37.0]  
Maximum panel thickness: 0.15 [3.8]

Flush-Rectangular

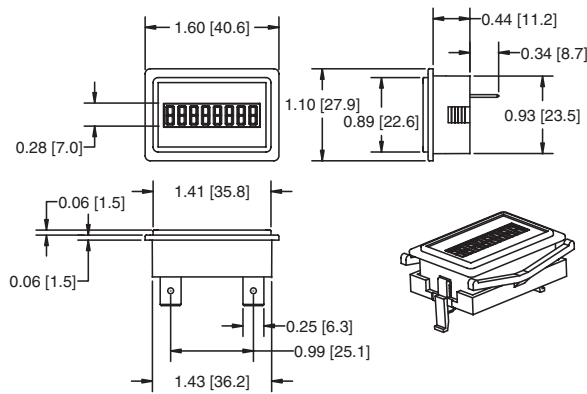

Panel cutout: 1.45 X 0.95 [24.0 x 37.0]  
Maximum panel thickness: 0.15 [3.8]

Applications

Medical Devices



Control Panels



Secondary Equipment



Test Equipment



Production Equipment

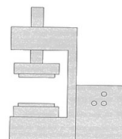

Office Equipment



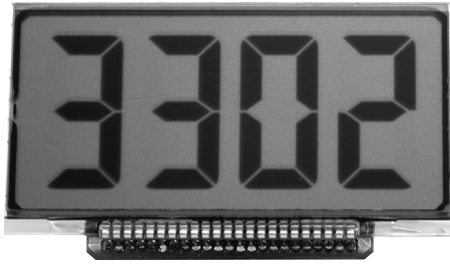

Front

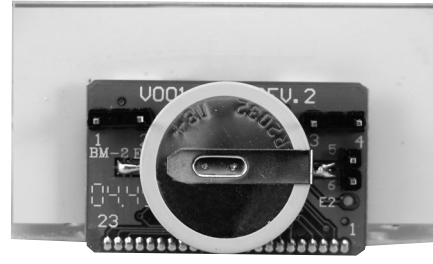

Back

**Description**

The Redington Model 3302-4322 LCD counter provides a very economical, large 4-digit display, 0.75" [19mm] with a PCB mount. The counter is designed to accept dry contact or other solid-state switch-mode inputs. It has remote reset capability that is compatible with dry contact or switch-mode inputs. The maximum pulse frequency is up to 30Hz. The counter is battery operated with a rated life of 5 years.

**Features**

- Large LCD display
- Always on display
- Contact closure input & remote reset
- PCB mount

**Options**

- Non-reset

**Specifications**

**Display:** Large 0.75" [19mm], LCD, black on light background  
**Displays:** 4 digit (9999)  
**Inputs:** Dry contact closure or solid-state switch-mode input  
**Remote Reset:** Dry contact closure or solid-state switch-mode input  
**Battery Life:** 5 years (with 50% input duty cycle)

**Temp. Range:** -40°F to 185°F [-40°C to 85°C]  
**Agency Approvals:** CE Compliant  
**Termination:** (6) 0.025 [0.64] square pins  
**Weight:** 0.5oz, [14g]

**Model Description**

3302-4322 4-digit, LCD, 0.75" [19] PCB mount, dry contact closure input and remote reset

**Dimensions**

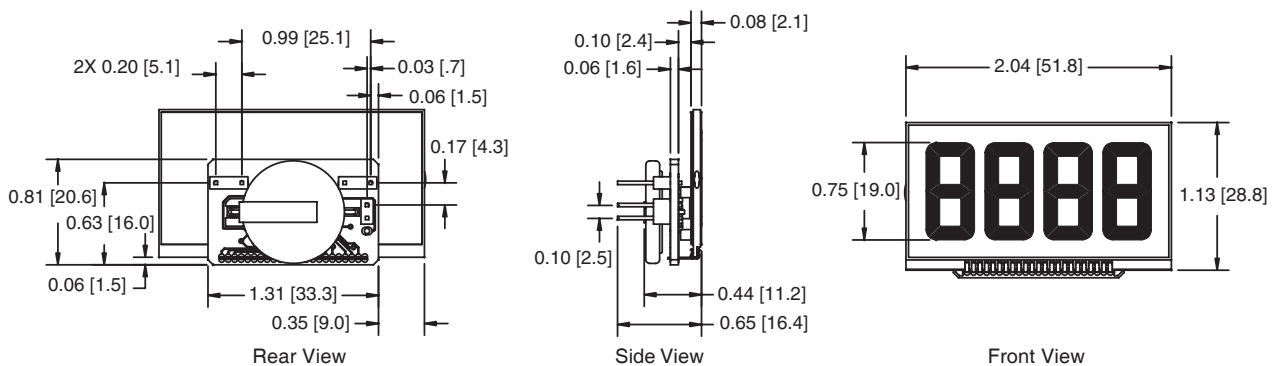

**Applications**

Panel Builders



Test Equipment



Medical Devices



Events or People Counter



Office Equipment



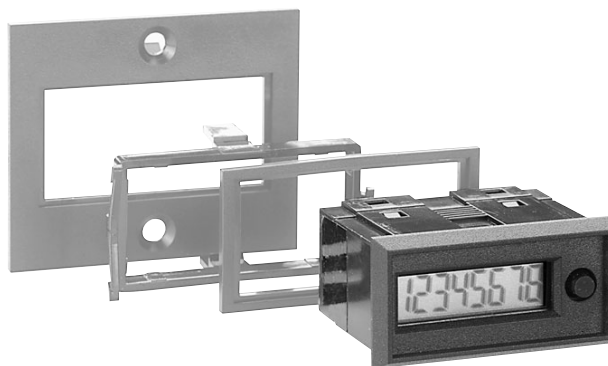

**Description**

The Model 52 LCD 8-digit Miniature Electronic Counter offers a low cost general purpose miniature totalizer with a 10 year internal lithium battery. It is an economical replacement for electromechanical counters and is available for bi-directional or quadrature inputs. Front panel reset button can be enabled or disabled by a wiring connection or external contact closure. Easy snap in mount fits 0.94" x 1.89" [24 x 48mm] DIN panel cutout (0.98" x 1.97" [25 x 50mm] with adaptor).

**Features**

- Contact closure/open collector low speed count input with integral de-bounce circuitry (5200-0000)
- Quad signal compatible using 5211-0000 plug-in adaptor. This permits add/subtract counting in synchronization with forward/reverse motion without count loss or gaining additional counts. (5210-0000).
- Front panel meets NEMA4/IP65 specification for indoor use.
- Counting up to 10kHz.
- 7mm black characters, on a light background, LCD display.

**Options**

- Optional triggering from any voltage between 5 and 240VAC or VDC using the 5202-0000 adaptor and the Model 5200-0000.
- Choice of mounting available, front panel with supplied bezel or rear mounting clip.

**Specifications**

<b>Power:</b>	Internal lithium battery. Nominal life 10 years	<b>Low Speed Count Input:</b>	(Model 5200-0000) (PIN4) contact closure/open collector with integral de-bounce circuitry. 30Hz maximum, negative edge triggered, 0.7V threshold, 15 mS minimum closure time
<b>Display:</b>	8 digit black LCD, 0.3" [7.6mm] characters with leading zero blanking	<b>High Speed Count Input:</b>	(Model 5210-0000) (PIN 5) electronic input 10kHz maximum, negative edge triggered, 0.7 threshold 50µS minimum pulse length, TTL/CMOS compatible +14°F to +140°F [-10°C to +60°C]
<b>Manual Reset Enable:</b>	(PIN 2) link to COMMON (PIN 1) to enable front panel reset button	<b>Operating Temperature:</b>	-4°F to +140°F [-20°C to +60°C]
<b>Count Range:</b>	99,999,999 display rollover to zero, leading zeros suppressed	<b>Storage Temperature:</b>	-4°F to +140°F [-20°C to +60°C]
<b>External Reset:</b>	(PIN 3) contact closure/open collector, negative edge triggered. 0.7 threshold. 15mS minimum closure time	<b>Environmental Protection:</b>	Front panel is NEMA4/IP65 using gasket supplied.
<b>Direction Input:</b>	(Model 5210-0000) (PIN 4) connection or electronic input TTL/CMOS compatible. Add= no connection or > 2.4 volts (logic 1) ; subtract = connect to COMMON or, 0.7V (logic 0) direction input must precede count input by 5µS (minimum) for valid operation.	<b>Mounting:</b>	Either with clip mount or two front screws with bezel supplied.
		<b>Approvals:</b>	UL Recognized, CE Compliant
		<b>Weight:</b>	2 oz. [57g]

<b>Models</b>	<b>Description</b>	<b>Models</b>	<b>Description</b>
<b>5200-0000</b>	Counter/Unidirectional, count up	<b>5202-0000</b>	High voltage pulse adaptor (for use with 5200-0000 only)
<b>5210-0000</b>	Counter/Bidirectional, (Add/Subtract)	<b>5211-0000</b>	Quadrature adaptor (for use with 5210-0000 only)
<b>5201-0000</b>	Terminal block adaptor		

\* Items in bold are normally in factory stock.



Accessory Descriptions

5201-0000 SCREW TERMINAL ADAPTOR

The 5201-0000 adaptor provides screw terminal connections for conductors up to 0.098in<sup>2</sup> [2.5mm<sup>2</sup>]. The adaptor snaps on to the rear of the counter. The terminals are protected to the touch and are easily accessible.

5202-0000 HIGH VOLTAGE ADAPTOR

This is a plug in adaptor for use with the 5200-0000. This input adaptor module permits the use of high voltage input pulses from 5-240VAC or VDC. Opto-isolation provides input to output isolation of 5000V. The adaptor plugs into the rear of the counter by integral clips. Connection is by screw terminal for conductors up to 0.098in<sup>2</sup> [2.5mm<sup>2</sup>].

5211-0000 QUAD ADAPTOR

This is a plug-in adaptor for the (5210-0000) add/subtract counter. It converts the signal from a quadrature output sensor such as a shaft encoder into count and direction signals. The adaptor retains direct access to the external reset on the 5210-0000. Connection by screw terminals for conductors up to 0.098in<sup>2</sup> [2.5mm<sup>2</sup>].

Dimensions

Model 5200-0000

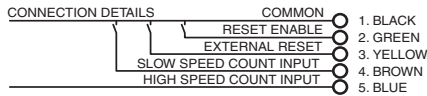
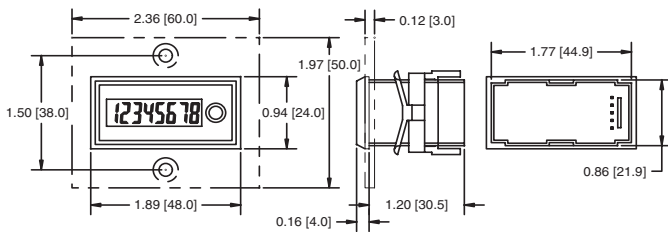

Panel Cutout

1.87" x 0.87" [47.5 x 22.1] +0.02 - 0.0, 1.97" X 0.98" [50.0 x 24.9] with panel adaptor.)

Maximum Panel Thickness

0.3" [7.5mm]

Model 5210-0000

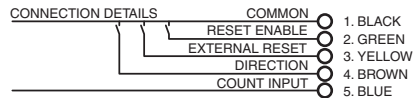
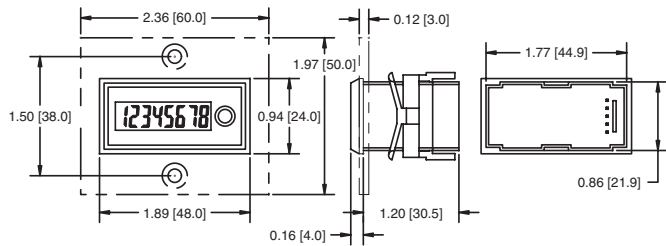

High Voltage Adaptor

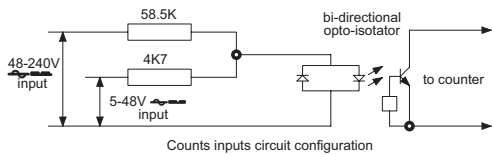

Counts inputs circuit configuration

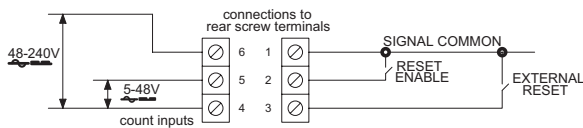

High Voltage Adaptor

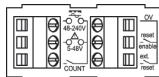

Quadrature

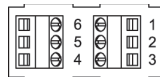

Terminal Block



Applications

Flow Meter

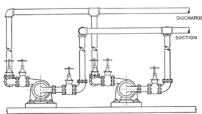

Positioning

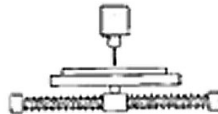

Rotation

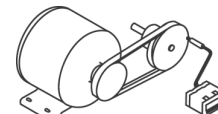



Description

The Model 53 Electronic Totalizer with 7 or 8 LCD digits is ideal as a replacement for electromechanical totalizers or where external power is not available. Powered by an internal lithium battery these products are highly reliable and provide the user with a choice of several options; with or without reset and multiple count ranges for optimized performance. The case is available in either tan or black.

Features

- Lithium battery
- Choice of non-reset or remote reset
- Switch (no-voltage), 3-30VDC, 20-250VAC/VDC

Options

- Case color
- Mounting adapter plates
- 8 digits
- 5003-001S - gasket
- Low AC voltage (4-30 VAC)

Specifications

**Figures:** 7 or 8 LCD figures, 0.32" [8mm] high  
**Reset:** Remote, manual, and non-reset  
**Speed:**  
**7 Digit:** 0-40 counts/second [min. 12.5ms - on, 12.5ms - off]  
 0-150 counts/second [min. 3.3ms - on, 3.3ms - off]  
**8 Digit:** 0-35 count/second [min. 14.3ms - on, 14.3ms - off]  
**Inputs:** Switch (no-voltage), 3-30VDC, 20-250VAC/VDC  
 Vih 20VAC/3VDC minimum  
 Vil 3VAC/1VDC maximum  
**Power:** Self-powered (internal lithium battery)  
**Mounting:** Panel with clip  
**Terminations:** Terminal block, or connector with 8" [200mm] wire leads  
**Battery Life:** ~20years

**Weight** 2 oz. [57g]  
**Temperature:**  
**Operating:** -4°F to +140°F [-20°C to +60°C]  
**Storage:** -40°F to +165°F [-40°C to +75°C]  
**Humidity:** 0 to 95% RH, non-condensing  
**Vibration**  
**Operating:** 10 to 55Hz, 0.01" [0.25mm] double amplitude  
**Non-Operating:** 10 to 55Hz, 0.03" [0.75mm] double amplitude  
**Shock**  
**Operating:** 10G  
**Non-Operating:** 30G  
**Dielectric:** 1000VAC 50/60Hz for 1 minute  
**Accuracy:** 100% [Provided Signal Meets Stated Parameters]  
**Approvals:** UL Recognized, CSA Certified, CE Compliant

Note: When interfacing the Model 53 with a Solid State Relay or AC Sensor, the leakage current needs to be considered. Contact the factory or see the application note at [www.redingtoncounters.com](http://www.redingtoncounters.com) for further information.

Models

Models	Reset			Input			Speed/cps		Terminations		Color	
	remote	none	manual	switch	3-30VDC	20-250VAC/VDC	40/150	40	term. block	8" wire leads	Tan	Black
<b>5300-0000</b>	X			X			X		X		X	
5300-0001	X			X			X		X			X
<b>5300-0100</b>	X		X	X			X		X		X	
5300-0101	X		X	X			X		X			X
<b>5300-1000</b>	X				X		X		X		X	
5300-1001	X				X		X		X			X
<b>5300-1100</b>	X		X		X		X		X		X	
5300-1010	X				X		X			X	X	
5300-1011	X				X		X			X		X
<b>5300-2000</b>	X					X		X	X		X	
5300-2001	X					X		X	X			X
<b>5300-2100</b>	X		X			X		X	X		X	
5300-2200		X				X		X	X		X	
5300-2201		X				X		X	X			X

\* Items in bold are normally in factory stock.

All part numbers shown are for 7 digit models. Please contact the factory for information on 8 digit models.

Dimensions

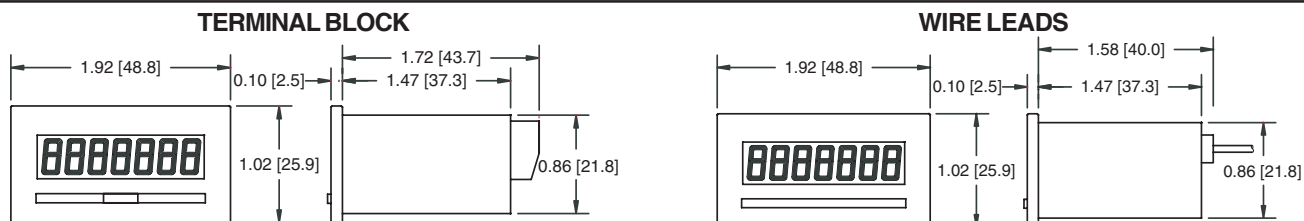



Operating Instructions

MOUNTING:

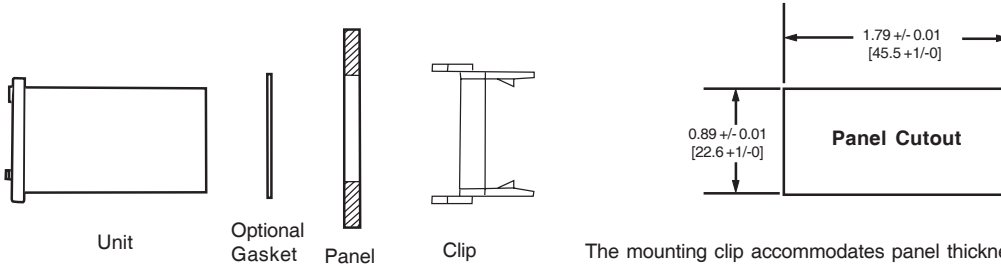

The mounting clip accommodates panel thicknesses up to 1/4" [6.4mm].

Panel adapter plates are available in flush and 2 hole mount to fit various panel cutouts. Consult the factory for availability.

WIRING:

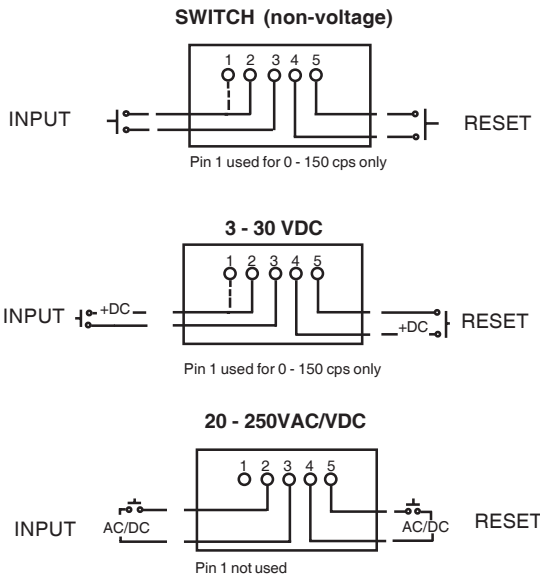

Color code for the 8" [203mm] lead wires (24AWG) are:

- 1 - Yellow
- 2 - Blue
- 3 - Black
- 4 - Violet
- 5 - Gray

Terminal block will accept wire sizes from 14 to 24AWG.

3 - 30VDC units are protected for transient voltages up to 50 volts with pulse widths of up to 1 second at a 1% duty cycle (including reverse polarity).

The operating AC frequency range is 40 to 400Hertz.

NOTES:

INPUT / RESET PARAMETERS

To insure proper performance from totalizers the following minimum input durations are required:

0 to 35 cps totalizer	Minimum	14.3 ms "on"	14.3 ms "off"	The count is activated on the falling edge.
0 to 40 cps totalizer	Minimum	12.5 ms "on"	12.5 ms "off"	The count is activated on the falling edge.
0 to 150 cps totalizer	Minimum	3.3 ms "on"	3.3 ms "off"	The count is activated on the rising edge.

All resettable totalizers can be reset by a pulse with a minimum duration of 6 milliseconds.

DUAL RANGE TOTALIZER PROTECTION FEATURE:

Dual range totalizers have a built-in range protection feature. This feature will protect the totalizer from receiving a false signal from the unused input line. Once a totalizer has received an input from pin #1 or pin #2, it will only accept inputs from that pin until the unit has been reset. For example, if a totalizer is run in the low speed range and it is determined that a high speed range is preferred, simply switch the input from pin #2 to pin #1 and reset the totalizer to de-activate this range protection feature. Conversely, if a totalizer is run in high speed range and it is determined that a low speed range is preferred, simply switch the input from pin #1 to pin #2 and reset the totalizer.

SPECIAL WIRING OPTION

There is an internal connection between pin 3 and pin 5, a single wire can be used by connecting it to either pin 3 or pin 5. This option **does not** apply for units with input of 20 - 250VAC/VDC or manual reset enable.

OPTIONAL INPUTS:

Optional control circuitry (such as transistors) may be used as inputs provided that such circuitry provides the required parameters of the model used.

Applications

Number of Parts

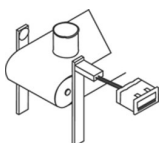

Shear

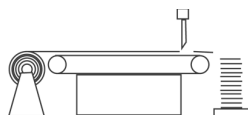

Packaging Line

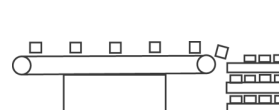



**Description**

The Model 54 is a 7 or 8 digit LCD Totalizer with PCB mounting. Ideal for applications where PCB mounting, high reliability and long life are important. Units are 7 or 8 digits and come with their own lithium battery. Totalizers have two count speed ranges, 40cps or 150cps and are customer selectable.

**Features**

- Remote or non-reset
- Selectable count speeds
- High reliability
- PCB mounting
- Long life lithium battery
- Dry contact closure or voltage pulse input

**Options**

- Hour Meter
- Tachometer
- Without battery
- 8 digits

**Specifications**

<b>Figures:</b>	7 LCD , 0.315" (8mm)	<b>Power:</b>	Lithium battery (rated @ ~ 20 years)
<b>Reset:</b>	Remote and non-reset	<b>Mounting:</b>	PCB: 0.45" Dia. [11.4mm] Pins, 0 .2" [5.1mm] spacing:
<b>Speed: 7 Digit:</b>	0 - 40 counts/second (min. 12.5ms-on, 12.5ms-off)	<b>Temperature:</b>	
	0 - 150 counts/second (min.3.3,s-on, 3.3ms-off)	<b>Operating:</b>	-4°F to +140°F [-20°C to +60°C]
<b>8 Digit:</b>	0 - 35 counts/second (min. 14.3ms-on,14.3ms-off)	<b>Storage:</b>	-40°F to +165°F [-40°C to +75°C]
<b>Inputs:</b>	Switch (no-voltage), 3-30VDC, 20-250VAC/VDC	<b>Weight:</b>	2oz [57g]
	Vih 20VAC/3VDC minimum		
	Vil 3VAC/1VDC maximum		

Models	Description	Models	Description
5400-0010	40/150 cps, switch, remote reset, w/battery	5400-1010	40/150 cps, 3-30VDC, remote reset, w/battery

\* All part numbers shown are for 7 digit models. Please contact the factory for information on 8 digit models.

**Dimensions**

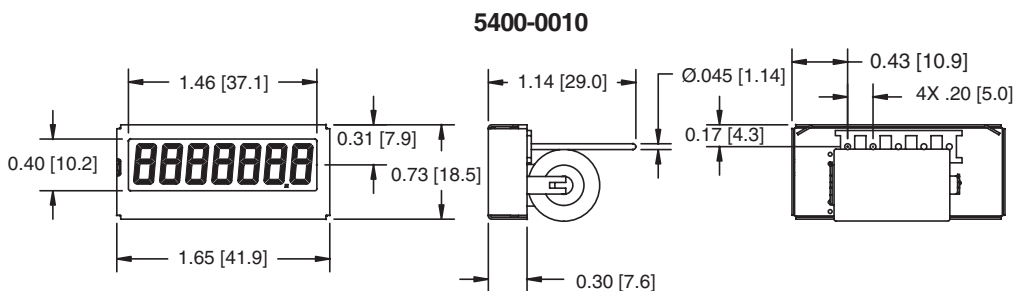

**Applications**

Number of Parts

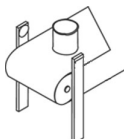

Total Operating Time

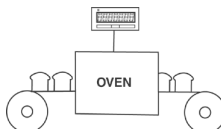

Motor/Pulley Speed

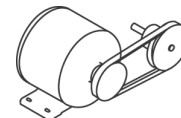



Description

A 6 figure, battery powered, push-button or key reset, electronic counter, available in base mount or panel mount configuration. No external power supply is required. Large 0.50" [12mm] LCD figures for fast, easy reading. Operates at 6-240 VAC or VDC. Long lasting internal lithium battery. Attractive styling and silent operation make these models equally well-suited for lab or office equipment applications.

Features

- No external power supply needed
- Long life lithium battery
- Large easy reading display
- Operates at 6 to 240 VAC or VDC

Options

- Non-reset
- Remote reset

Specifications

<b>Figures:</b>	6 LCD figures, 0.50" [12mm] high	<b>Mounting:</b>	Base or panel
<b>Reset:</b>	Push-button, or lock and key	<b>Terminations:</b>	(2) #22 AWG 221°F [105° C] wire leads, 8" [203mm] long
<b>Speed:</b>	0-40 counts/second, (min. 12.5ms - on, 12.5ms - off)	<b>Temp. Range:</b>	-14°F to +122°F [-26°C to +50°C]
<b>Input:</b>	6-240VAC or VDC	<b>Power Source:</b>	Internal lithium battery
	Vih 6VAC/VDC minimum	<b>Weight:</b>	18 oz. [510g]
	Vil 2VAC/VDC maximum		

Note: When interfacing the Model 94 with a Solid State Relay or AC Sensor, the leakage current needs to be considered. Contact the factory or see the application note at [www.redingtoncounters.com](http://www.redingtoncounters.com) for further information.

Models Description

<b>9415-001</b>	6 figure, base mount, push-button reset
<b>9415-003</b>	6 figure, panel mount, push-button reset
<b>9415-005</b>	6 figure, panel mount, lock and key reset

\* Items in bold are normally in factory stock.

Dimensions

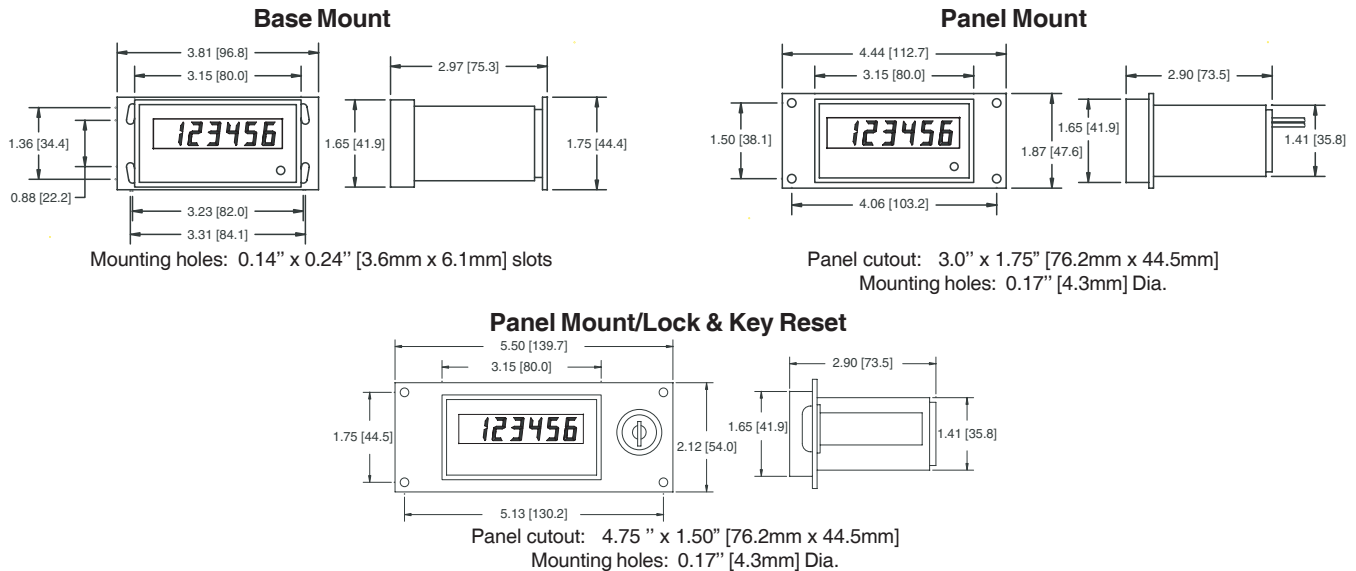

Applications

Office equipment



Production

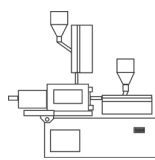

Test labs



Control panels

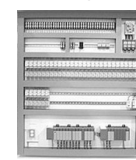





**Description**

A hand-held reset counter with a 4 digit LCD display and push-button actuator. Case is made of a high impact plastic and comes with a key chain for ease of use. All electronic construction provides a long life counter with no mechanical parts to wear out. The Tally is a handy way to count inventory, attendance, traffic, blood cells, or food portions.

**Features**

- LCD display
- Long life

**Specifications**

**Digits:** 4 LCD's 0.24" [6mm] high  
(maximum count 9999)

**Reset:** Push button

**Battery Operating Life:** 250 days (typical)

**Weight:** 0.7 oz [20g]

**Color:** Gray body with yellow buttons

**Models Description**

E1-1804 Electronic Hand Tally

\* Item is normally in factory stock.

**Dimensions**

2.0"L x 1.7"W x 0.7"D [50.8mmL x 43.2mmW x 17.8mmD]

**Operating Instructions**

1. Press ON/RESET key to power ON the unit.
2. Press STEP key once, the LCD will display '1'
3. Press START key, the LCD will display '1'
4. Press COUNT key to continue the counting, the LCD will display from 1 to 2 to 3 to 4 etc.

Anytime you want to restart the count from '0', repeat the above steps.

Note: If '0000' is displayed, you can press 1 ON/RESET to reset to '0'



**Battery Replacement**

When the display gets dim or the counter works erratically, replace the button type battery. Use 1 X G13A or equivalent.

**Applications**

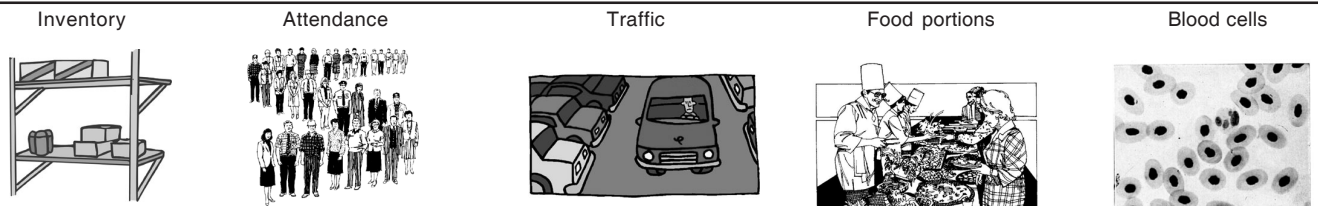



Add Model



Add/Subtract Model

**Description**

The Redington Models E2 & E3 offer an electronic version of the popular Hand Tally counter and are available with a choice of Add only or Add/Subtract models. Counts are input using large positive action buttons. The Add model has a single count button and the Add/Subtract model has two separate count buttons. The "+" button (green) will add a count to the total and the "-" button (red) will subtract a count from the total. When activated, an audible "beeper" sounds every count to verify that a count has been registered. All electronic components provides a long life counter with no moving parts to wear out. The counter is manufactured from impact-resistant plastic, combining lightweight with outstanding durability.

**Features**

- Add or Add/Subtract models
- Beep at every count with the option of switching the sound off for silent operation
- Cannot accidentally reset or turn off; On/Off/Reset button must be held down for 3 seconds to reset
- Long life battery (replaceable) - typically 250 days without sound
- Large LCD display
- No mechanical parts to wear out
- Large rubber buttons for comfort of use
- Ergonomically designed for ease of use
- Carrying cord
- Light weight

**Specifications**

<b>Display:</b>	4 digit LCD 0.35" [9mm] high	<b>Operating Temperature:</b>	+32°F to +122°F [0°C to +50°C]
<b>Battery Operating Life:</b>	250 days (without sound)	<b>Weight:</b>	0.7 oz (20g)
<b>Reset:</b>	Push button	<b>Color:</b>	Black case with blue buttons (Add Only) or green and red buttons (Add/Subtract)

Models	Description	Dimensions
E2-1804	Electronic Hand Tally (Add only)	2.4" L x 1.4" W x 0.6" D [60mm x 35mm x 15mm]
E3-1804	Electronic Hand Tally (Add/Subtract)	

\* All Items are normally in factory stock.

**Operating Instructions**

- Press On/Off/Reset button to power ON the unit
- Add model - Press count button to increment count
- Add/Subtract model - Press the "+" button to Add, Press the "-" button to Subtract
- To reset counter press the On/Off/Reset button for 3 seconds
- To switch the sound Off/On at any time, hold the count button down for 3 seconds
- To turn Off, press the On/Off/Reset for 3 seconds when counter display is at "0"

**Battery Replacement**

When the display gets dim, replace the battery. Use 1 type AG10 1.5 V or equivalent. Observe polarity (±) during replacement

**Applications**

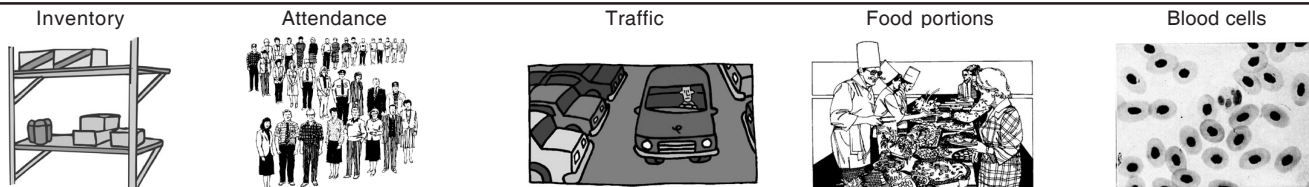



Description

A 6 figure general purpose, rugged, electromechanical counter, either panel or base mounted, with manual knob reset, key reset, or non-reset. Frame and housing provides rigid support for accurate alignment and trouble-free use. Distinctive numerals enhance visibility under adverse viewing conditions.

Features

- Panel or base mount
- Rigid support for accurate alignment
- Enhanced visibility
- Manual knob, key or non-reset

Options

- Voltages
- Lead lengths
- Terminations
- Mounting
- 1071-024S - additional key for model 1026

Specifications

**Figures:** 6 figures, white on black, 0.19" [5mm] high  
**Reset:** Knob, lock and key, or non-reset  
**Speed:** 1,000 counts/minute (min. 30ms - on, 30ms - off)  
**Voltage:** 24, 115, 230 VAC or 24 VDC (+/- 10%, but not to exceed 10 volts)  
**Power:** 7.8 watts (nominal)

**Mounting:** Base or panel  
**Terminations:** (2)#22 AWG 105°C wire leads, 8" [203mm] long  
**Operating Life:** Beyond 50 million counts  
**Temp. Range:** -15°F to +140°F [-26°C to +60°C]  
**Approvals:** UL Recognized, CSA Certified, CE Compliant  
**Weight:** 18 to 22 oz. [510 to 624g]

Models

Description

1-1006	230VAC, base mount, knob reset
<b>2-1006</b>	115VAC, base mount, knob reset
3-1006	24VAC, base mount, knob reset
8-1006	24VDC, base mount, knob reset
2-1016	115VAC, base mount, non-reset
P1-1006	230VAC, panel mount, knob reset
<b>P2-1006</b>	115VAC, panel mount, knob reset

Models

Description

P3-1006	24VAC, panel mount, knob reset
P8-1006	24VDC, panel mount, knob reset
P2-1016	115VAC, panel mount, non-reset
P31-1026	230VAC, panel mount, lock and key reset
<b>P32-1026</b>	115VAC, panel mount, lock and key reset
P33-1026	24VAC, panel mount, lock and key reset
P38-1026	24VDC, panel mount, lock and key reset

\* Items in bold are normally in factory stock.

Dimensions

Base Mount

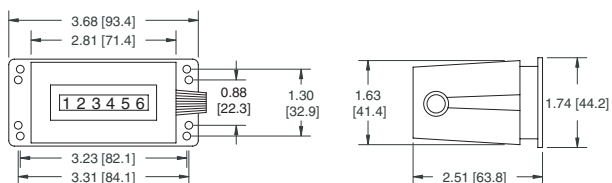

Mounting holes: 0.15" [3.8mm] Dia.

Panel Mount

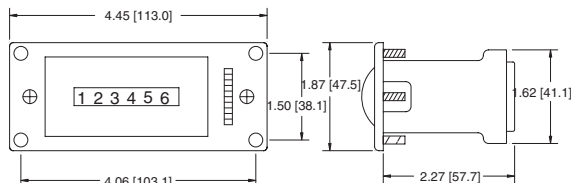

Screws provided: 6-32 x 0.6 [15.2mm]  
Panel cutout: 3.85" x 1.75" [97.8 x 44.5mm]

Lock and Key Reset

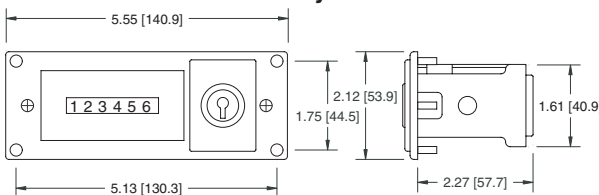

Screws provided: 6-32 x 0.6 [15.2mm]  
Panel cutout: 4.88" x 1.75" [124.0 x 44.5mm]

Applications

Molding machines

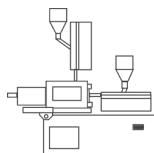

Punch press

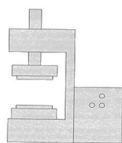

Printing presses

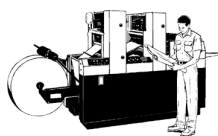

Test labs



Secondary Machines





Description

A 7 figure, rugged, electromechanical counter, either panel or base mounted, with manual knob reset, key reset, or non-reset. Frame and housing provides rigid support for accurate alignment and trouble-free use. Large, easy-to-read numerals assure readability.

Features

- 7 figure
- Panel or base mount
- Rigid support for accurate alignment
- Large easy to read numerals

Options

- Voltages
- Lead lengths
- Terminations
- Wheel color

Specifications

**Figures:** 7 figures, white on black, 0.19" [5mm] high  
**Reset:** Knob, lock and key, or non-reset  
**Speed:** 1,000 counts/minute  
 (min. 30ms - on, 30ms - off)  
**Voltage:** 24, 115, 230 VAC or 24 VDC  
 (+/- 10%, but not to exceed 10 volts)  
**Power:** 7.8 watts (nominal)

**Mounting:** Base, panel, or behind the panel  
**Terminations:** (2)#22 AWG 105°C wire leads, 8" [203mm] long  
**Operating Life:** Beyond 50 million counts  
**Temp. Range:** -15°F to +140°F [-26°C to +60°C]  
**Approvals:** UL Recognized, CSA Certified, CE Compliant  
**Weight:** 14 to 18 oz. [397 to 510g]

Models	Description	Models	Description
1-1007	230VAC, base mount, knob reset	P2-1007	115VAC, panel mount, knob reset
2-1007	115VAC, base mount, knob reset	P2-1027	115VAC, panel mount, lock and key reset
3-1007	24VAC, base mount, knob reset	P8-1027	24VDC, panel mount, lock and key reset
8-1007	24VDC, base mount, knob reset	R2-1007	115VAC, behind the panel, knob reset
2-1017	115VAC, base mount, non-reset	R2-1017	115VAC, behind the panel, non-reset

Dimensions

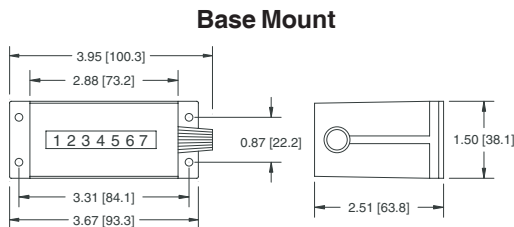

Mounting holes: 0.15" [3.8mm] Dia.

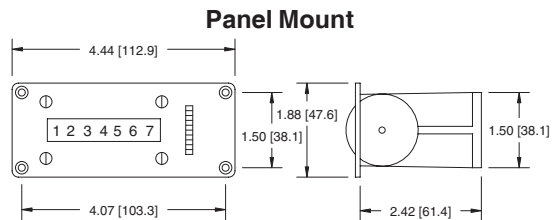

Screws provided: 6-32 x 0.6 [15.2mm]  
Panel cutout: 3.85" x 1.75" [97.8 x 44.5mm]

Lock and Key Reset

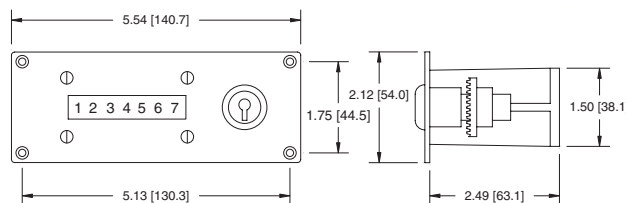

Screws provided: 6-32 x 0.6 [15.2mm]  
Panel cutout: 4.88" x 1.75" [124.0 x 44.5mm]

Applications

Molding machines

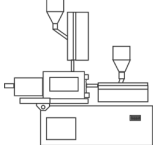

Punch press

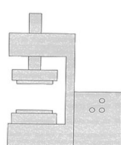

Printing presses

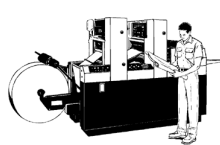

Test labs



Secondary Machines



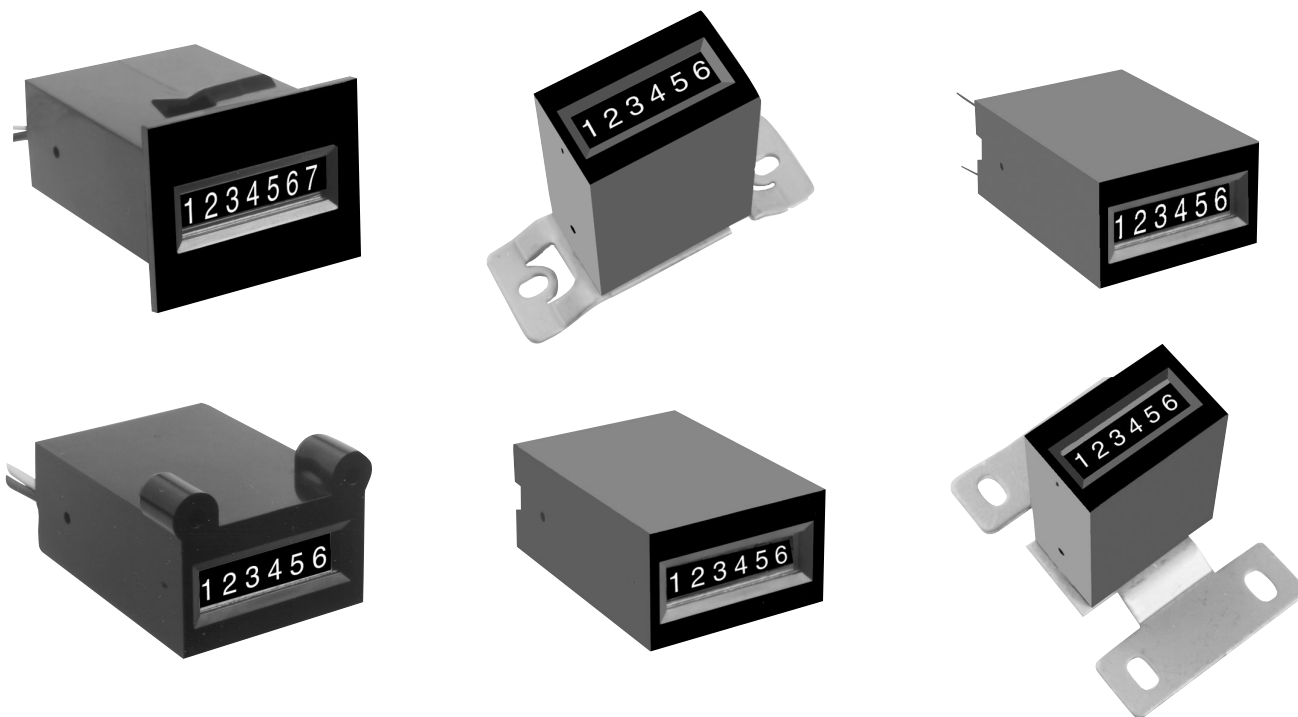

**Description**

The Model 40 is a low cost, non-reset totalizer, available with 6-7 figures (white on black background). A wide choice of operating voltages and mountings make this product adaptable for most applications. The Model 40 is an ideal solution for applications that require low cost and product reliability.

**Features**

- Low cost
- Small size
- DC and AC

**Options**

- 6 or 7 figure
- Multiple mounting choices
- Voltages

**Specifications**

**Figures:** 6 or 7 figures, white on black, 0.12" (3 mm) high  
**Reset:** Non-reset  
**Speed:** 600 counts/minute (min. 50ms - on, 50ms - off)  
**Voltage:** 115 VAC, 5, 12 or 24 VDC (+ 10/-15% tolerance)  
**Power:** 1.4 watts AC, 1.0 watts DC (nominal)  
**Mounting:** Rear, behind the panel, snap-in, base or PCB mount

**Terminations:** (2)#22 AWG 221°F [105°C] wire leads, 10.5" [266.7mm] long or (2) 0.03" [0.8mm] Dia. pins for PCB mounting  
**Operating Life:** Beyond 3 million counts  
**Temp. Range:** +23°F to +104°F [-5°C to +40°C]  
**Weight:** Less than 1 oz. [28g]

Models	Description	Models	Description
2-4016	115VAC, 6 figure, rear mount, wire leads	2-4017	115VAC, 7 figure, rear mount, wire leads
R2-4016	115VAC, 6 figure, behind the panel mount, wire leads	R2-4017	115VAC, 7 figure, behind the panel mount, wire leads
R9-4016	12VDC, 6 figure, behind the panel mount, wire leads	R9-4017	12VDC, 7 figure, behind the panel mount, wire leads
SR2-4016	115VAC, 6 figure, snap-in panel mount, wire leads	SR2-4017	115VAC, 7 figure, snap-in panel mount, wire leads
T2-4016	115VAC, 6 figure, PCB mount, pins	T2-4017	115VAC, 7 figure, PCB mount, pins
V8-4016	24VDC, 6 figure, V-base mount, wire leads	V8-4017	24VDC, 7 figure, V-base mount, wire leads



Dimensions

Rear Mount

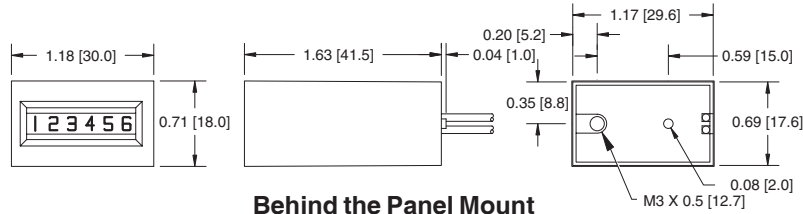

Behind the Panel Mount

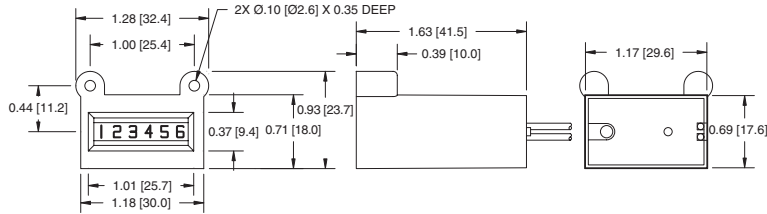

Snap-In Panel Mount

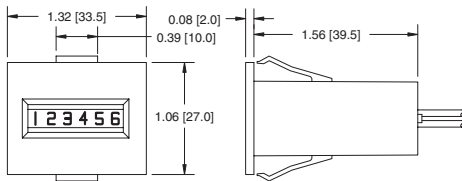

PANEL CUTOUT: 1.20 [30.5] X 0.96 [24.4]  
RECOMMENDED PANEL THICKNESS: 0.04 [1.0] to 0.08 [2.0]

V-Base Mount

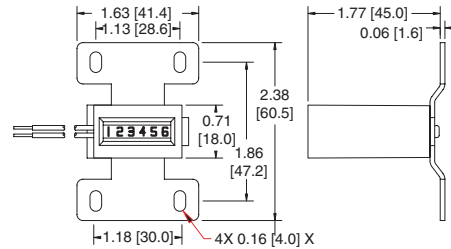

D-Base Mount

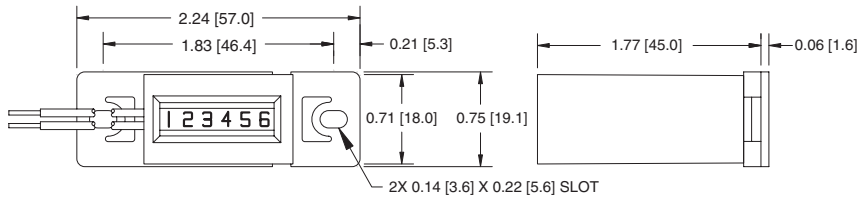

PCB Mount

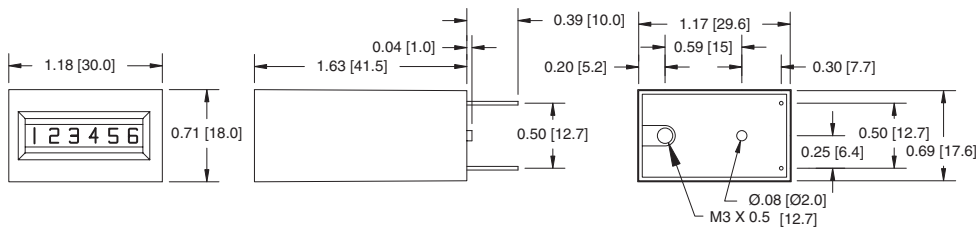

Applications

Vending/Gaming machines

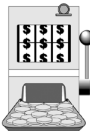

Photocopiers



Items dispenser



Office equipment





Description

A 6 figure, non-reset counter. Metal/plastic frame assembly assures ruggedness while one piece cover discourages tampering. Precision molded internal gearing requires no lubrication for long, accurate count life. Applications include warranty verification, electronic game counting, coin box tallies, or wherever small size, highly visible numerals, and solid construction are critical.

Features

- Small size
- Highly visible numerals
- Solid construction

Options

- Voltages
- 7 figure
- Lead length
- Special connectors
- Extended temperature range
- Count x 2

Specifications

**Figures:** 6 figures, white on black, 0.18" [4.6mm] high  
**Reset:** None  
**Speed:** 600 counts/minute  
 (min. 50ms - on, 50ms - off)  
**Voltages:** 115VAC, 24VDC  
 (+/- 10%, but not to exceed 10 volts)  
**Power:** 1.5 watts (nominal)

**Mounting:** Rear, behind the panel, base, or combination  
**Terminations:** (2) #22 AWG 221°F [105°C] wire leads, 10" [254mm] long  
**Operating Life:** Beyond 3 million counts  
**Temp. Range:** +23°F to +104°F [-5°C to +40°C]  
**Approvals:** UL Recognized, CE Compliant  
**Weight:** 2.5 oz. [71g]

Models	Description	Models	Description
2-4416	115VAC, 6 figure, rear mount	V2-4416	115VAC, 6 figure, base mount
8-4416	24VDC, 6 figure, rear mount	V8-4416	24VDC, 6 figure, base mount
R2-4416	115VAC, 6 figure, behind the panel mount	RV2-4416	115VAC, 6 figure, combination mount
R8-4416	24VDC, 6 figure, behind the panel mount	RV8-4416	24VDC, 6 figure, combination mount

Dimensions

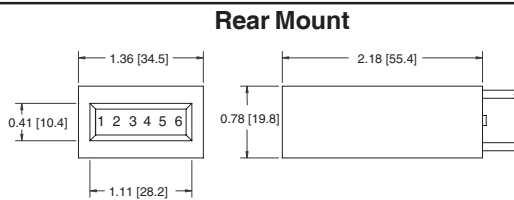

Mounting hole: For M3 screw

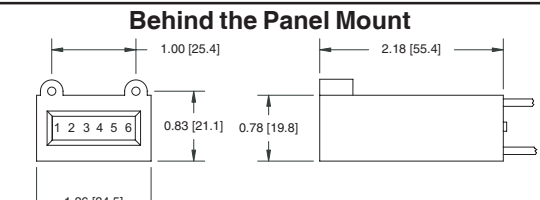

Mounting holes: For M3 self tapping screw

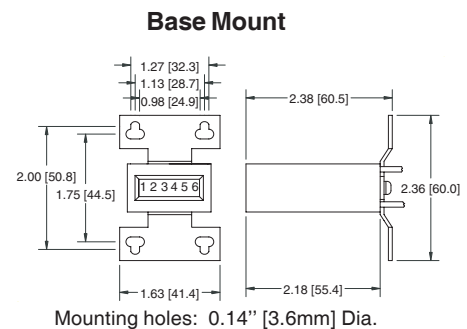
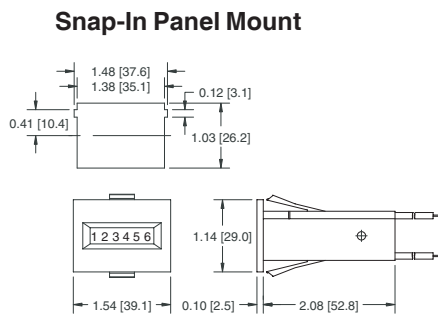

Mounting holes: 0.14" [3.6mm] Dia.

Applications

Warranty verification



Coin box tallies



Electronic game counting





Description

A compact, economical, 6 or 7 figure, non-reset, electromechanical counter designed for general purpose industrial and commercial counting applications. It is designed for a variety of mounting methods as required by the application. Commonly used for coin-operating equipment, photocopiers and vending machines.

Features

- 6 or 7 figure
- Compact
- Non-reset
- Variety of mounting options

Options

- Voltages
- Lead lengths
- 5 figure

Specifications

**Figures:** 6 or 7 figures, white on black, 0.17" [4.3mm] high  
**Reset:** None  
**Speed:** 1,000 counts/minute AC, (min. 30ms - on, 30ms - off)  
 1,200 counts/minute DC, (min. 25ms - on, 25ms - off)  
**Power:** AC: 24VAC ~ 4 watts  
 115VAC ~ 3.5 watts  
 230VAC ~ 5 watts  
 DC: 12/24VDC ~ 2 watts

**Mounting:** Panel or base  
**Terminations:** (2) #22 AWG 105°C wire leads, 12" [305mm] long  
**Operating Life:** Beyond 10 million counts  
**Temp. Range:** -15°F to +140°F [-26°C to +60°C]  
**Approvals:** UL Recognized, CSA Certified, CE Compliant  
**Weight:** 3.5 oz. [99g]

Models	Description	Models	Description
<b>P2-4816</b>	115VAC, 6 figures, P panel mount	D8-4817	24VDC, 7 figures, D base mount
P8-4816	24VDC, 6 figures, P panel mount	P2-4817	115VAC, 7 figures, P panel mount
R2-4816	115VAC, 6 figures, R panel mount	P8-4817	24VDC, 7 figures, P panel mount
SR2-4816	115VAC, 6 figures, SR panel mount	R8-4817	24VDC, 7 figures, R panel mount
SR8-4816	24VDC, 6 figures, SR panel mount	SR8-4817	24VDC, 7 figures, SR panel mount
V1-4816	230VAC, 6 figures, V base mount	V2-4817	115VAC, 7 figures, V base mount
<b>V2-4816</b>	115VAC, 6 figures, V base mount	V8-4817	24VDC, 7 figures, V base mount
V3-4816	24VAC, 6 figures, V base mount		
V8-4816	24VDC, 6 figures, V base mount		
V9-4816	12VDC, 6 figures, V base mount		

\* Items in bold are normally in factory stock.

Applications

Control panels

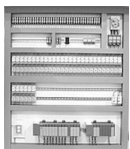

Gaming machines



Vending machines



Coin-operated equipment

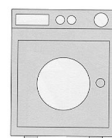

Photocopiers







Dimensions

D - Mount

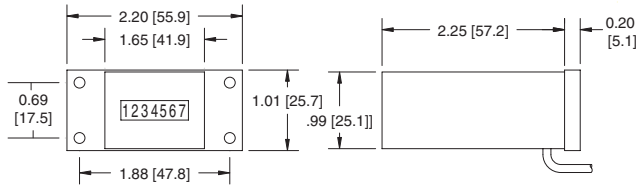

Mounting holes: 0.15" [3.8] Dia.

SR - Mount

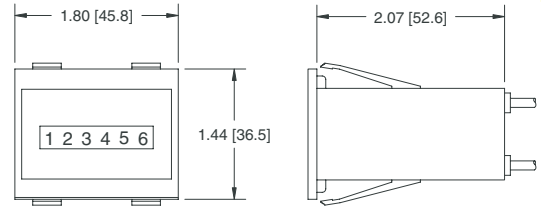

Panel cutout: 1.67" x 1.29" [42.4 x 32.8mm]  
Recommended panel thickness: 0.04" to 0.08" [1.0 to 2.0mm]

P - Mount

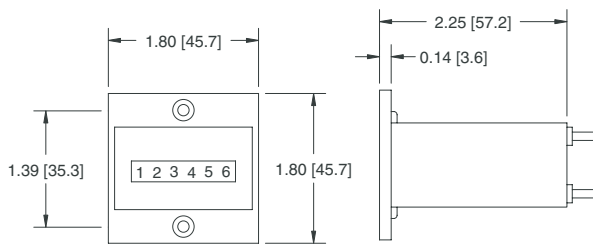

Mounting holes: For #5 flat head screw  
Panel cutout: 1.72" x 1.05" [43.7 x 26.7mm]

R - Mount

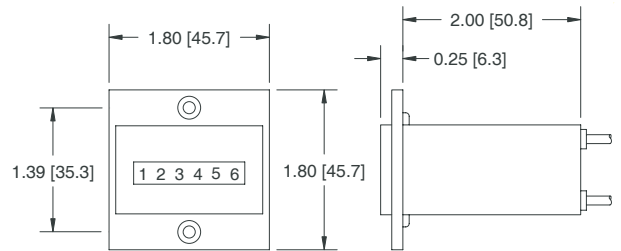

Mounting holes: For #5 flat head screw  
Panel cutout: 1.72" x 1.05" [43.7 x 26.7mm]

V - Mount

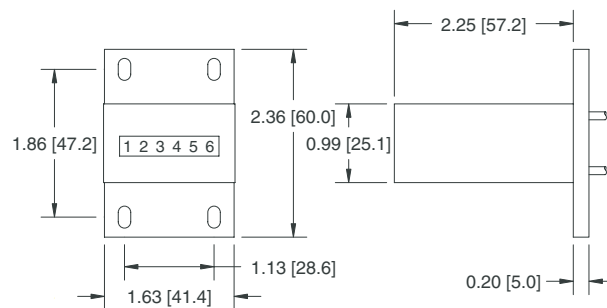

Mounting holes: 0.16" x 0.28" [4.1 x 7.1mm] slots



**Description**

Economically priced 4 and 6 figure push-button reset, electromechanical counter designed for use where limited space is a factor and when reliability is critical. Rugged operating mechanisms require no lubrication or maintenance. Compact size and minimum space requirements make the Model 49 ideally suited for use in control panels, business machines, and test equipment.

**Features**

- Compact
- No maintenance
- Quick reset

**Options**

- Voltages
- Extended temperatures
- 4 or 6 figure

**Specifications**

**Figures:** 4 or 6 figures, white on black, 0.16" [4mm] high  
**Reset:** Push-button  
**Speed:** 600 counts/minute  
 (min. 50ms - on, 50ms - off)  
**Voltages:** 115VAC, 24VDC  
 (+10% to - 15%)  
**Power:** AC: 115VAC ~ 3 watts  
 DC: 24VDC ~ 2 watts

**Mounting:** Panel, base, or bail  
**Termination:** (2) #22 AWG 105°C wire leads, 10" [254mm] long  
**Operating Life:** Beyond 100 million counts  
**Temp. Range:** -15°F to +140°F [-26°C to +60°C]  
**Approvals:** UL Recognized, CE Compliant  
**Weight:** 4 oz. [113g] (4 fig.), 5 oz. [142g] (6 fig.)

Models	Description
B2-4904	115VAC, 4 figure, bail mount
B8-4904	24VDC, 4 figure, bail mount
<b>D2-4904</b>	115VAC, 4 figure, base mount
<b>P2-4904</b>	115VAC, 4 figure, panel mount
<b>P8-4904</b>	24VDC, 4 figure, panel mount
P9-4904	12VDC, 4 figure, panel mount

Models	Description
B2-4906	115VAC, 6 figure, bail mount
B8-4906	24VDC, 6 figure, bail mount
D2-4906	115VAC, 6 figure, base mount
<b>P2-4906</b>	115VAC, 6 figure, panel mount
<b>P8-4906</b>	24VDC, 6 figure, panel mount
P9-4906	12VDC, 6 figure, panel mount

\* Items in bold are normally in factory stock.



Dimensions

Panel Mount - 4 Figure

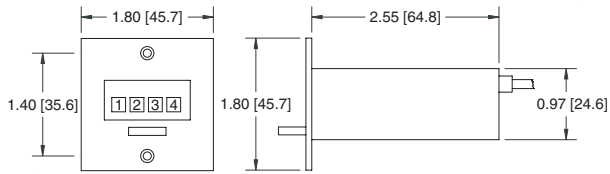

Panel cutout: 1.46" x 1.01" [37.1 x 25.7mm]  
Mounting holes: For #4 flat head screw

Panel Mount - 6 Figure

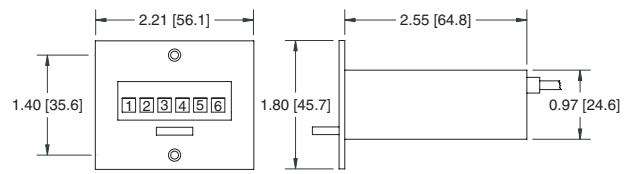

Panel cutout: 2.00" x 1.01" [50.8 x 25.7mm]  
Mounting holes: For #4 flat head screw

Bail Mount - 4 Figure

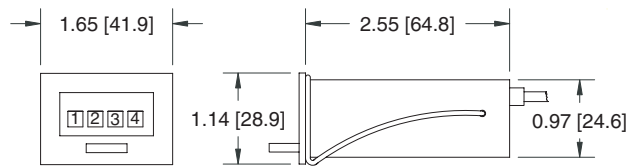

Panel cutout: 1.46" x 1.01" [37.1 x 25.7mm]

Bail Mount - 6 Figure

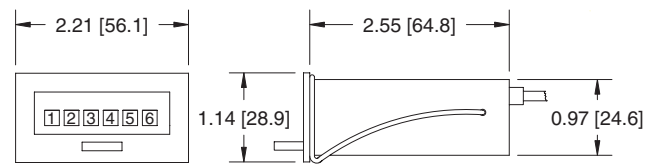

Panel cutout: 2.00" x 1.01" [50.8 x 25.7mm]

Base Mount - 4 Figure

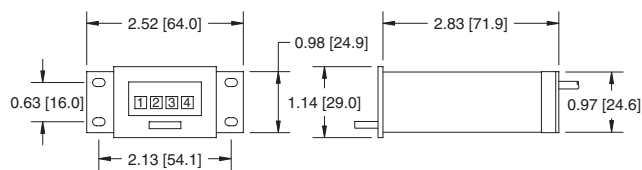

Mounting holes: 0.12" x 0.20" [3.1 x 5.1mm] slots

Base Mount - 6 Figure

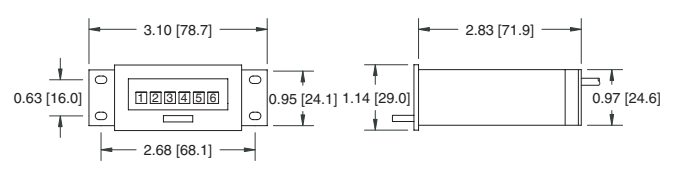

Mounting holes: 0.12" x 0.20" [3.1 x 5.1mm] slots

Applications

Test Equipment



Control Panels

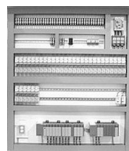

Business Machines



Medical devices





**Description**

A general purpose, 4 figure electromechanical reset counter perfect for applications where long life, reliability, and accuracy are mandatory. Several mounting alternatives and large, easy-to-read numbers are combined in a rugged housing.

**Features**

- Rugged housing
- Long life
- Reliable
- Accurate

**Options**

- Voltages
- Lead lengths
- Terminations

**Specifications**

**Figures:** 4 figures, white on black, 0.19" [5mm] high  
**Reset:** Knob  
**Speed:** 1,000 counts/minute  
 (min. 30ms - on, 30ms - off)  
**Voltage:** 115 VAC  
 (+/-10%, but not to exceed 10 volts)  
**Power:** 5 watts (nominal)

**Mounting:** Base, panel, or behind the panel  
**Terminations:** (2)#22 AWG 105°C wire leads, 8" [203mm] long  
**Operating Life:** Beyond 50 million counts  
**Temp. Range:** -15°F to +140°F [-26°C to +60°C]  
**Approvals:** UL Recognized, CSA Certified, CE Compliant  
**Weight:** 10 oz. [284g]

**Models Description**

**2-1284** 115VAC, Base mount, knob reset  
**D2-1284** 115VAC, D panel mount, knob reset

**Models Description**

**P2-1284** 115VAC, P panel mount, knob reset  
**PR2-1284** 115VAC, PR panel mount, knob reset

\* Items in bold are normally in factory stock.

**Dimensions**

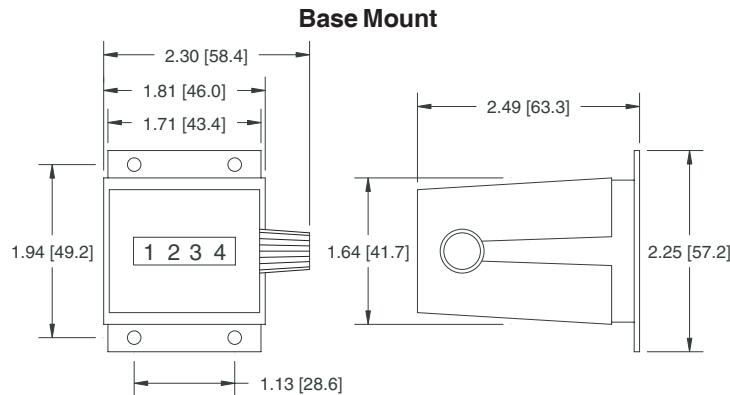

Mounting holes: 0.15" [3.8mm] Dia.

**Applications**

Production totals

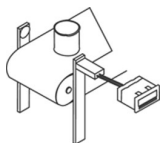

Medical devices



Office machines



Control Panels

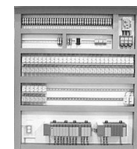



**Description**

An extremely long life, 6 figure, electromechanical counter available in panel mounting versions with manual push-button reset. High count speeds, bold numbers, and contemporary design make this ideal in office, graphic arts, medical and computer applications.

**Features**

- High count speed
- Bold numbers
- Contemporary design

**Options**

- Voltages
- Lead lengths
- Terminations

**Specifications**

**Figures:** 6 figures, white on black, 0.15" [4mm] high  
**Reset:** Push-button  
**Speed:** 1,000 counts/minute AC, (min. 30ms - on, 30ms - off)  
 1,500 counts/minute DC, (min. 20ms - on, 20ms - off)  
**Voltages:** 115VAC, 24VDC  
 (+/- 10%, but not to exceed 10 volts)  
**Power:** 2.8 watts (nominal)

**Mounting:** Panel  
**Terminations:** Solder terminals  
**Operating Life:** Beyond 200 million counts  
**Temp. Range:** -15°F to +140°F [-26°C to +60°C]  
**Approvals:** UL Recognized, CSA Certified, CE Compliant  
**Weight:** 8 oz. [227g]

**Models Description**

P2-3106 115VAC, P panel mount, manual reset  
**R2-3106** 115VAC, R panel mount, manual reset  
 P8-3206 24VDC, P panel mount, manual reset

**Models Description**

P9-3206 12VDC, P panel mount, manual reset  
 R8-3206 24VDC, R panel mount, manual reset

\* Items in bold are normally in factory stock.

**Dimensions**

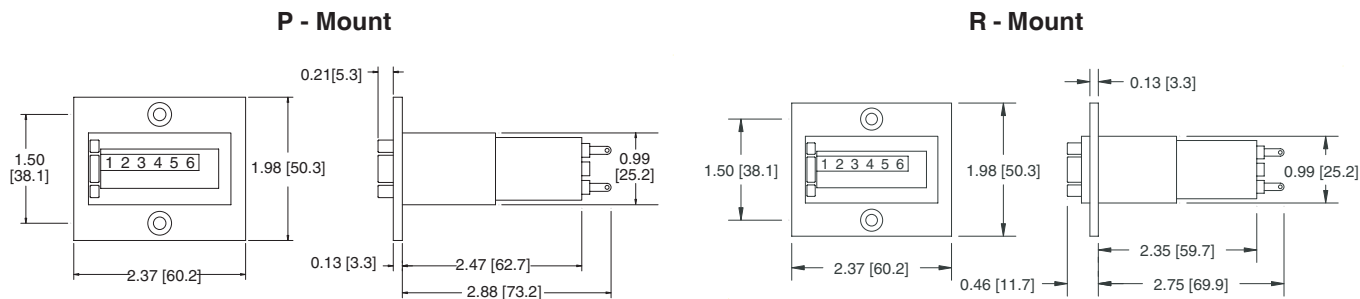

Mounting holes: For #8 flat head screw  
 Panel cutout: 2.02" x 1.05" [51.3 x 26.7mm]

**Applications**

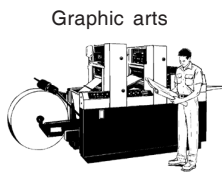

Graphic arts



Office equipment

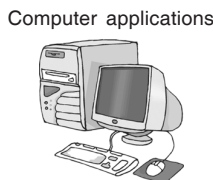

Computer applications



Medical equipment

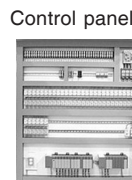

Control panels



**Description**

A 5 figure medium duty counter designed for applications where a rotary counter with a quick reset is desirable. When a 1' circumference measuring wheel is used with our standard counter, the counter will display feet and inches. Consult the factory if you have custom applications.

**Features**

- Counter will add and subtract
- Push button reset
- Versatile mounting
- 1,000 revolutions per minute (100 feet per minute)

**Options**

- Double shaft
- Wheel color
- Figure color
- Ratios
- Mounting
- Case color
- 98WF - Measuring Wheel - 12" circumference

**Specifications**

**Figures:** 5 figures, 0.20" [5mm] high  
**Reset:** Push-button  
**Rotation:** Top going  
**Shaft Extension:** 0.250" diameter, left hand or right hand

**Speed:** 1,000 revolutions/minute (100 feet/minute)  
**Operation Life:** Beyond 50 million  
**Temp. Range:** -15°F to 140°F [-26°C to +60°C]  
**Weight:** 10 oz. [283g]

**Models**

**Description**

11-0825 Left-hand, top-going, add & subtract

**Models**

**Description**

11-0845 Right-hand, top-going, add & subtract

**Dimensions**

**Left - Hand Shaft**

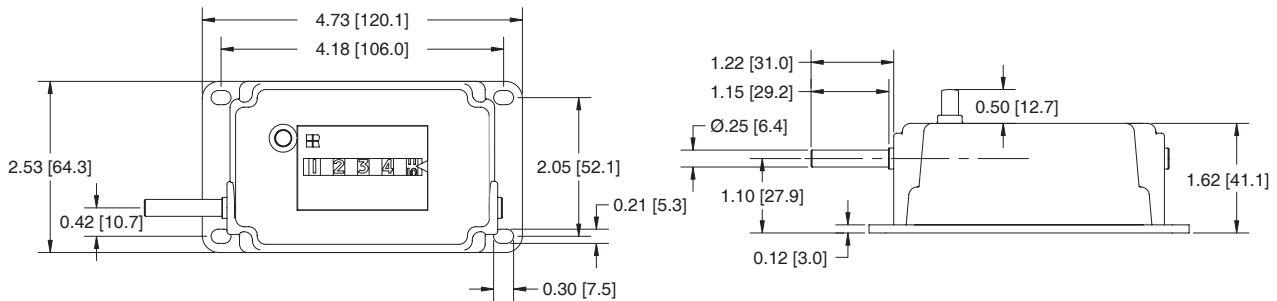

**Applications**

Linear measuring

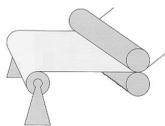

Machine revolutions

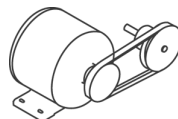

Positioning

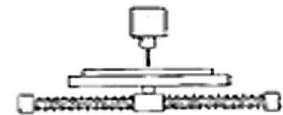



**Description**

The Model 14 is a compact, 5 figure, non-reset totalizer in a molded case with stainless steel shaft. Four types of drives are available and five case configurations. An ideal solution when application requirements call for a low cost and compact totalizer.

**Features**

- Four types of drives
- Choice of five case configurations
- Built-in non-overthrow mechanism on stroke counters
- Built-in internal stops on stroke counters
- 5 Figure: white on black background

**Options**

- Mounting
- Double shafts
- Figure background and case colors
- Sealed

**Specifications**

**Figures:** 5 figures, white on black, 0.16" [4mm] high  
**Reset:** Non-reset  
**Rotation:** Top-coming or top-going  
**Shaft Extension:** Right-hand or left-hand  
**Shaft Diameter:** 0.125" [3.2mm]  
**Speed:** Stroke: 1,000 counts/minute  
 Revolution: 3,000 counts/minute  
 Direct: 15,000 counts/minute  
 Rotary Ratchet:  
 3,000 counts/minute rotary mode  
 1,500 counts/minute in oscillating mode  
**Weight:** 0.5 oz. [14g]  
**Temp:** -40°F to +160°F [-40°C to +71°C]  
**Operating Torque:** Stroke; 0.8 to 2.0 in/oz  
 at 75°F Revolution; 0.15 in/oz  
 Direct; 0.15 in/oz  
 Rotary Ratchet; 0.3 to 1.0 in/oz

**Case Types:** Square base mount  
 Square panel mount  
 Square - no flange  
 Cylindrical base mount  
 Cylindrical panel mount  
**Drive Types:**  
 Stroke: typical count stroke 39° to 48°  
 typical total stroke 50° to 52°  
 Revolution: adds or subtracts one(1) count per revolution.  
 Direct: adds or subtracts ten (10) counts per revolution  
 Rotary Ratchet: adds ten (10) counts per revolution  
 adds only one (1) count per 36° to 60° oscillation.

Models	Description	Models	Description
11B-1415	lh, top coming, stroke, sq case, base mt	11B-1435	rh, top coming, stroke, sq case, base mt
11B-1515	lh, top coming, rev. drive, sq case, base mt	11B-1535	rh, top coming, rev. drive, sq case, base mt
11B-1615	lh, top coming, direct drive, sq case, base mt	11B-1635	rh, top coming, direct drive, sq case, base mt
11B-1715	lh, top coming, rotary rat., sq case, base mt	11B-1735	rh, top coming, rotary rat., sq case, base mt
11B-1425	lh, top going, stroke, sq case, base mt	11B-1445	rh, top going, stroke, sq case, base mt
11B-1525	lh, top going, rev. drive, sq case, base mt	11B-1545	rh, top going, rev drive, sq case, base mt
11B-1625	lh, top going, direct drive, sq case, base mt	11B-1645	rh, top going, direct drive, sq case, base mt
11B-1725	lh, top going, rotary rat., sq case, base mt	11B-1745	rh, top going, rotary rat., sq case, base mt

rat = ratchet  
 rev = revolution

lh = left hand  
 rh = right hand

sq = square  
 mt = mount

Similar products are also available in the following configurations:  
 Square case - panel mount change 11B to 11P  
 Square case - without flange change 11B to 11N  
 Cylindrical case - base mount change 11B to 21B  
 Cylindrical case - panel mount change 11B to 21P



Dimensions

Square Case Base Mount

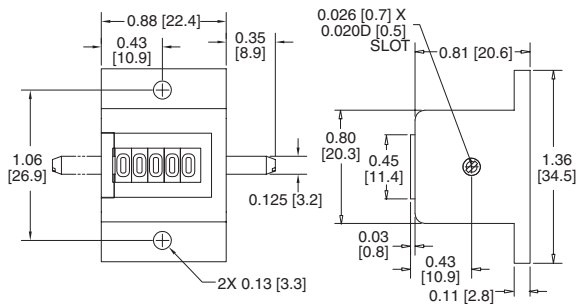

Square Case Without Flange

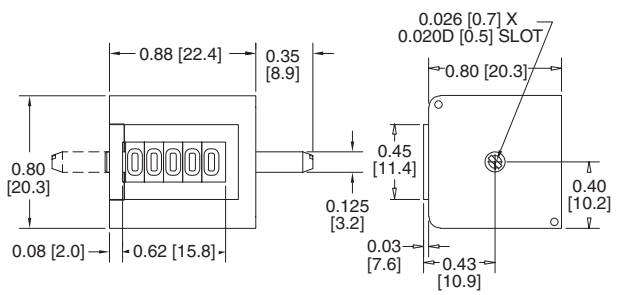

Square Case Panel Mount

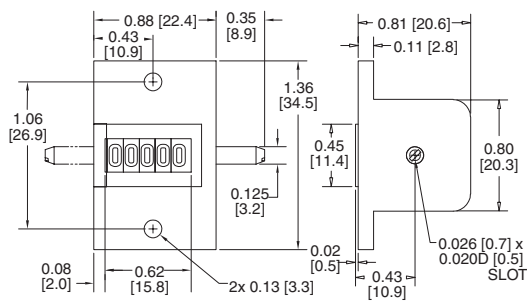

Cylindrical Case Base Mount

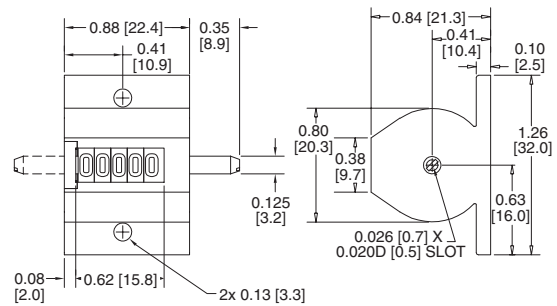

Cylindrical Case Panel Mount

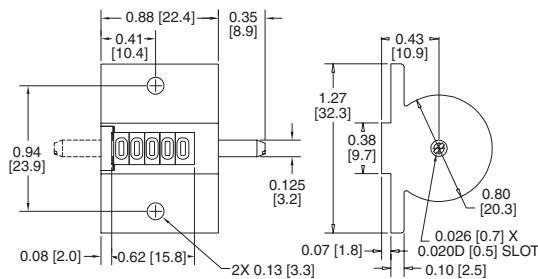

Short Lever (10006-028S)

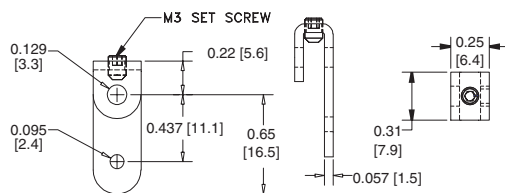

Standard Lever (10006-027S)

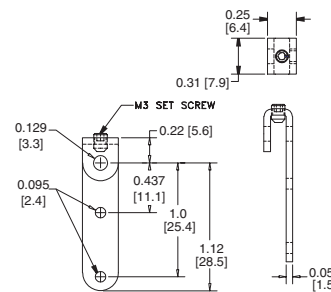

Applications

Circuit breakers



Vending machines



Gaming machines



Business and office equipment







**Description**

A 4 figure, hand-held or desk mounted reset counter with push-button actuator. Case is chrome plated steel. Hand-held model comes with thumb ring for ease of use. Single desk mounted style has plastic base with mounting holes. Multiple desk units, from 2 to 10, mounted on a single base with a common reset. These tallies are a convenient way to count inventory, attendance, traffic, blood cells, or food portions.

**Features**

- Chrome plated steel housing
- Long life

**Options**

- Multiple units

**Specifications**

**Figures:** 4 figures, white on black, 0.16" [4mm] high  
**Reset:** Knob  
**Operating Life:** Beyond 5 million counts

**Temp. Range:** -15°F to +140°F [-26°C to +60°C]  
**Weight:** 3.5 oz. [99g]

Models	Description	Models	Description
<b>12-1804</b>	Hand Tally with finger ring	3-1804-6	Versa Tally: 6 units, common reset and base
<b>13-1804</b>	Desk Tally with mousing base	3-1804-7	Versa Tally: 7 units, common reset and base
3-1804-2	Versa Tally: 2 units, common reset and base	3-1804-8	Versa Tally: 8 units, common reset and base
3-1804-3	Versa Tally: 3 units, common reset and base	3-1804-9	Versa Tally: 9 units, common reset and base
3-1804-4	Versa Tally: 4 units, common reset and base	3-1804-10	Versa Tally: 10 units, common reset and base
3-1804-5	Versa Tally: 5 units, common reset and base		

\* Items in bold are normally in factory stock.

**Dimensions**

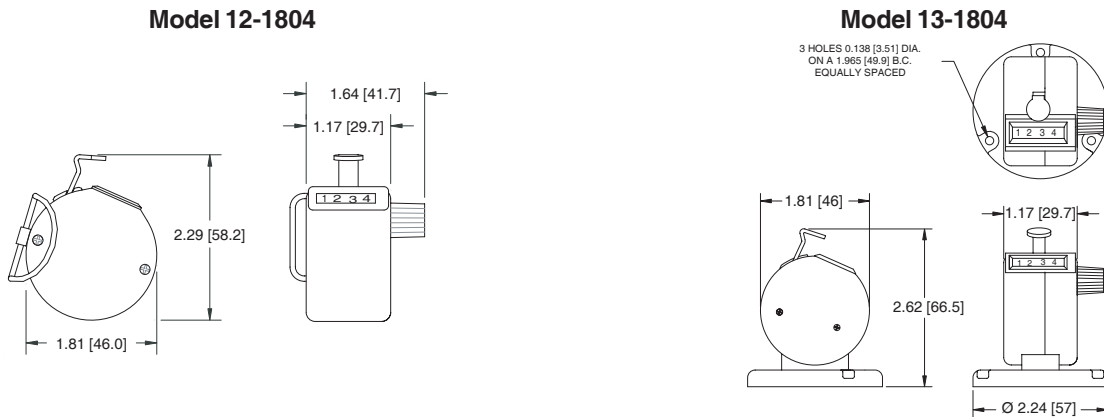

**Applications**

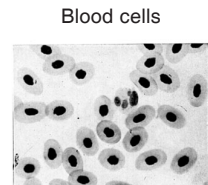
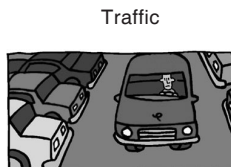



**Description**

The Redington "Victor" counters are manually operated mechanical totalizers ideal for use when you need to count more than one item at the same time. Models are available from a single counter to a maximum of 20 units (4 wide X 5 high). All modules have 4-figure counters and a common rotary reset for the entire row. Each unit can be easily labeled using removable paper tabs. Applications include Lab Counters, Traffic Surveys, Inventory Control, Inspection Tallies, QC Counters, Bus Counters and Point-of-Sale Records.

**Features**

- Paper tabs for labeling
- Common reset for each row
- Positive action pushbutton
- Lubrication not required
- Quick, simple to operate and accurate

**Options**

- Multiple units - up to 20 counters

**Specifications**

**Figures:** 4 figures, white on black, 0.12" [3mm] high  
**Reset:** Knob

**Weight:** ~3.0oz. [85g] per unit

Models	Description	Models	Description
11-1904	Modular Tally, single unit	14-1904	Modular Tally, 1 unit wide x 4 units high
21-1904	Modular Tally, 2 units wide x 1 unit high	24-1904	Modular Tally, 2 units wide x 4 units high
31-1904	Modular Tally, 3 units wide x 1 unit high	34-1904	Modular Tally, 3 units wide x 4 units high
41-1904	Modular Tally, 4 units wide x 1 unit high	44-1904	Modular Tally, 4 units wide x 4 units high
12-1904	Modular Tally, 1 unit wide x 2 units high	15-1904	Modular Tally, 1 unit wide x 5 units high
22-1904	Modular Tally, 2 units wide x 2 units high	25-1904	Modular Tally, 2 units wide x 5 units high
32-1904	Modular Tally, 3 units wide x 2 units high	35-1904	Modular Tally, 3 units wide x 5 units high
42-1904	Modular Tally, 4 units wide x 2 units high	45-1904	Modular Tally, 4 units wide x 5 units high
13-1904	Modular Tally, 1 unit wide x 3 units high		
23-1904	Modular Tally, 2 units wide x 3 units high		
33-1904	Modular Tally, 3 units wide x 3 units high		
43-1904	Modular Tally, 4 units wide x 3 units high		

**Dimensions**

Dimensions for a single unit are shown to the right. To calculate the approximate size of an assembled unit, add 1.5" [37] to the width for each additional unit in a row, and add 2.6" [66] to the depth and 1.5" [37] to the height, for each additional row.

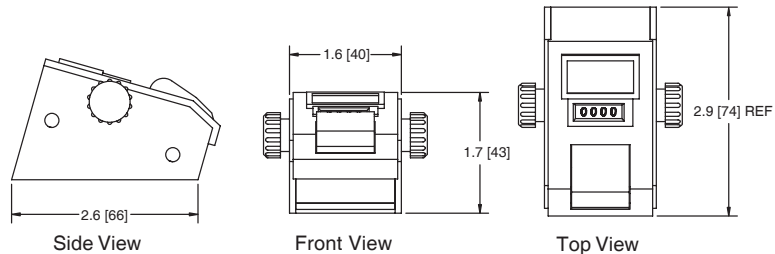

**Applications**

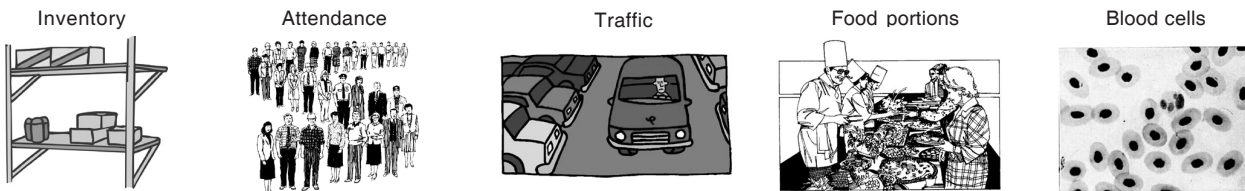



**Description**

A highly versatile, 5 figure stroke counter. Numbers are large and distinctive for easy viewing even when above or below eye level. Ruggedly built for years of trouble-free use. An excellent choice for counting parts produced.

**Features**

- Durable
- Large figures
- Reliable

**Options**

- Non-reset
- Large reset knob
- Right or left-hand shaft extension
- 10007-010S - additional lever and spring

**Specifications**

**Figures:** 5 figures, white on black, 0.19" [5mm] high  
**Reset:** Knob  
**Speed:** 1,000 counts/minute  
**Rotation:** Top-coming or top-going  
**Count Stroke:** 49° Min. - 60° Max.

**Shaft Extension:** Right-hand or left-hand  
**Shaft Diameter:** 0.125" [3.2mm]  
**Operating Life:** Beyond 50 million counts  
**Temp. Range:** -15°F to +140°F [-26°C to +60°C]  
**Weight:** 5 oz. [142g]

Models	Description	Models	Description
1-2015	Left-hand, top-coming, standard reset knob	1-2035	Right-hand, top-coming, standard reset knob
1-2025	Left-hand, top-going, standard reset knob	1-2045	Right-hand, top-going, standard reset knob

\* Items in bold are normally in factory stock.

**Dimensions**

**Right-Hand Shaft**

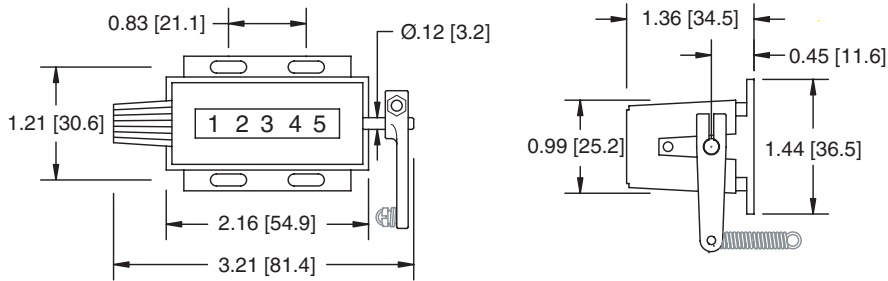

Mounting holes: 0.13" x 0.38" [3.3 x 9.7mm] slots

**Applications**

Punch press

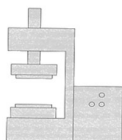

Machine cycles

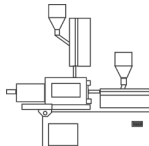

Secondary machines

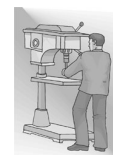



Description

A compact, 5 figure, rotary counter, indicating 10 counts/revolution. Design and compact size make it ideally suited for office and test equipment, coin counting and other direct reading instruments.

Features

- Compact size
- 5 figures
- Long life

Options

- Large reset knob
- Special shaft

Specifications

<b>Figures:</b>	5 figures, white on black, 0.19" [5mm] high	<b>Shaft Diameter:</b>	0.125" [3.2mm]
<b>Reset:</b>	Knob	<b>Ratio:</b>	10 counts/revolution
<b>Speed:</b>	1,000 revolutions/minute	<b>Operating Life:</b>	Beyond 50 million counts
<b>Rotation:</b>	Top-coming or top-going	<b>Temp. Range:</b>	-15°F to +140°F [-26°C to +60°C]
<b>Shaft Extension:</b>	Right-hand or left-hand	<b>Weight:</b>	4 oz. [113g]

Models	Description	Models	Description
1-2215	Left-hand, top-coming, add only	7-2225	Left-hand, top-going, add and subtract
1-2225	Left-hand, top-going, add only	<b>7-2235</b>	Right-hand, top-coming, add and subtract
1-2235	Right-hand, top-coming, add only	7-2245	Right-hand, top-going, add and subtract
1-2245	Right-hand, top-going, add only	1-2315	Left-hand, top-coming, add and subtract, non-reset
7-2215	Left-hand, top-coming, add and subtract	1-2325	Left-hand, top-going, add and subtract, non-reset

\* Items in bold are normally in factory stock.

Dimensions

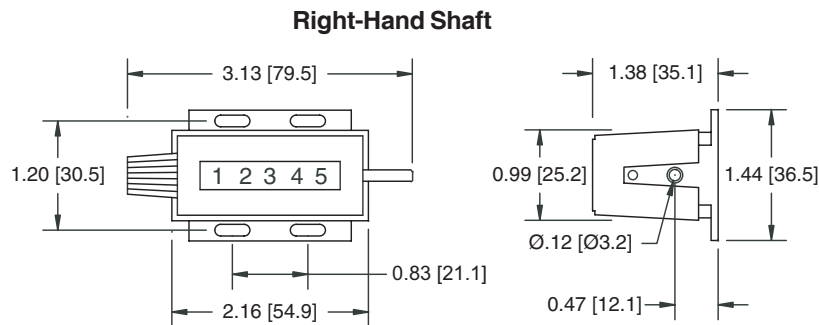

Mounting holes: 0.13" x 0.38" [3.3 x 9.7] slots

Applications

Production equipment

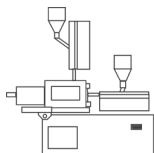

Spooling

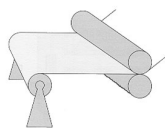

Positioning





**Description**

A heavy-duty, 5 figure, internal reset, stroke counter. Available in either right-hand or left-hand shaft extension.

**Features**

- Heavy-duty
- Internal reset

**Options**

- Right or left-hand shaft extension
- 1022-006S - additional spring

**Specifications**

**Figures:** 5 figures, white on black, 0.31" [8mm] high  
**Reset:** Internal - lift cover, reset wheels  
**Speed:** 750 counts/minute  
**Rotation:** Top-coming  
**Count Stroke:** 36° Min. - 45° Max.

**Shaft Extension:** Right-hand or left-hand  
**Operating Life:** Beyond 200 million counts  
**Temp. Range:** -15°F to +140°F [-26°C to +60°C]  
**Weight:** 24 oz. [680g]

**Models**

**Description**

1-2715 Left-hand, top-coming

**Models**

**Description**

1-2735 Right-hand, top-coming

\* Items in bold are normally in factory stock.

**Dimensions**

**Right-Hand Shaft**

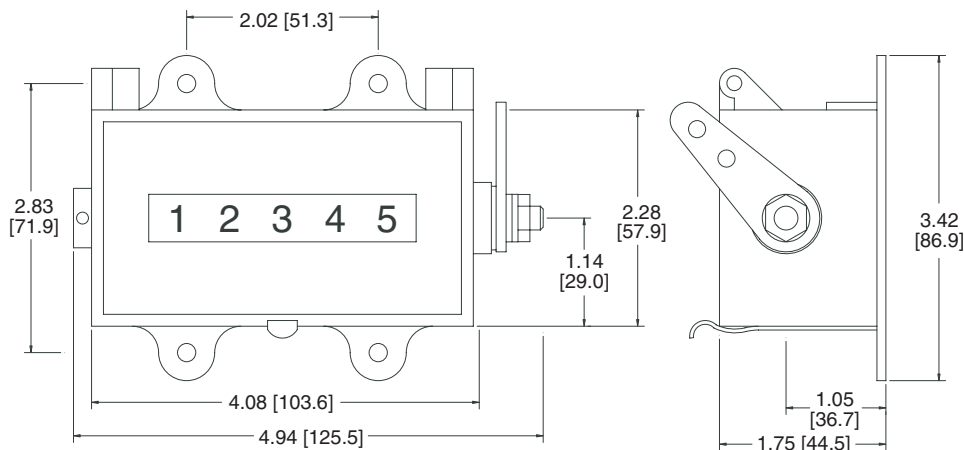

Mounting holes: 0.19" [4.8mm] Dia.

**Applications**

Punch press

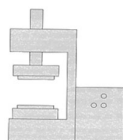

Secondary Machines



Machine cycles

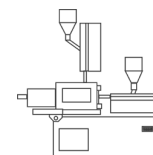



**Description**

A 5 figure, rugged stroke counter, with right-hand shaft extension, operating lever and attached spring. Rated at 600 counts per minute, this heavy-duty model is well suited for most industrial applications.

**Features**

- Heavy-duty
- 600 CPM
- 5 Figures

**Options**

- Lever modifications
- 1022-006S - additional spring

**Specifications**

**Figures:** 5 figures, white on black, 0.27" [7mm] high  
**Reset:** Knob, internal, or lock and key  
**Speed:** 600 counts/minute  
**Rotation:** Top-coming  
**Count Stroke:** 36° Min. - 45° Max.

**Shaft Extension:** Right-hand  
**Operating Life:** Beyond 200 million counts  
**Temp. Range:** -15°F to +140°F [-26°C to +60°C]  
**Weight:** 20 oz. [567g]

**Models Description**

3-2835 Right-hand, top-coming, internal reset  
**4-2835** Right-hand, top-coming, knob reset

**Models Description**

5-2835 Right-hand, top-coming, lock and key reset

\* Items in bold are normally in factory stock.

**Dimensions**

**Right - Hand Shaft**

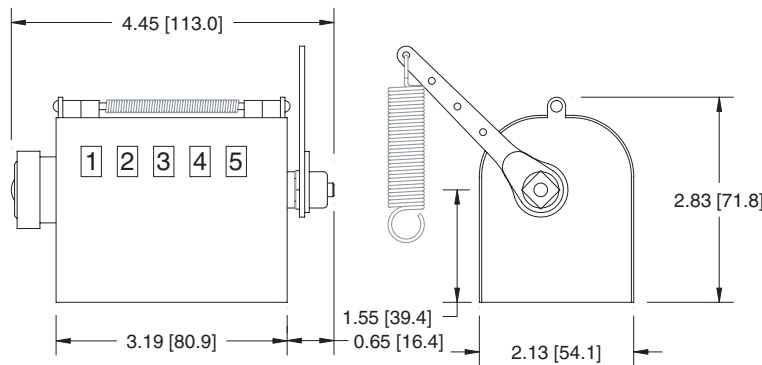

Mounting holes: 0.18" [4.6mm] Dia.

**Applications**

Punch press

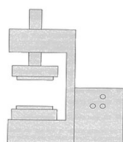

Machine cycles

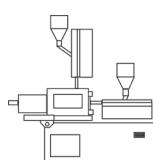

Shears

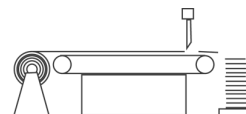



**Description**

A 6 figure, general purpose heavy duty industrial stroke counter designed for high count rates and continuous operation even under the most adverse operating conditions. Corrosion resistant material and finishes. Large, easy-to-read numbers.

**Features**

- Heavy duty
- High count rates
- Corrosion resistant

**Options**

- Non-reset
- Double shaft extensions
- Special mounting bases
- Weatherized versions
- 1022-006S - additional spring
- 1255-004S - additional lever

**Specifications**

**Figures:** 6 figures, white on black, 0.30" [7.6mm] high  
**Reset:** Knob or lock and key  
**Speed:** 1,000 counts/minute  
**Rotation:** Top-coming or top-going  
**Count Stroke:** 40° Min. - 70° Max.

**Shaft Extension:** Right-hand or left-hand  
**Shaft Diameter:** 0.25" [6.4mm]  
**Operating Life:** Beyond 100 million counts  
**Temp. Range:** -15°F to +140°F [-26°C to +60°C]  
**Weight:** 18 oz. [510g]

Models	Description	Models	Description
1-2916	Left-hand, top-coming, standard reset knob	1-2946	Right-hand, top-going, standard reset knob
1-2926	Left-hand, top-going, standard reset knob	2-2936	Right-hand, top-coming, lock and key reset
<b>1-2936</b>	Right-hand, top-coming, standard reset knob	<b>V1-2936</b>	Right-hand, top-coming, standard reset knob, V-base

\* Items in bold are normally in factory stock.

**Dimensions**

**Right - Hand Shaft**

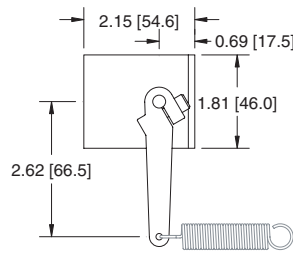
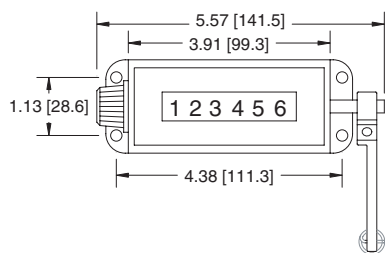

**V - Mount**

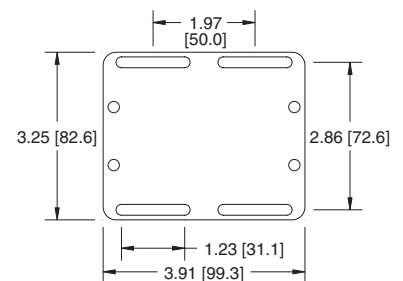

Mounting holes: 0.22" [5.6mm] Dia.

**Applications**

Punch presses

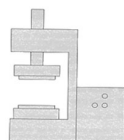

Shears

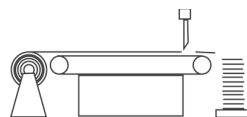

Cement trucks





Description

A 6 figure, general purpose, industrial rotary counter designed for use on equipment where environmental conditions are far from ideal. Various count ratios make it suitable for winding equipment, measuring devices and direct reading instruments.

Features

- Heavy duty
- High count rates
- Corrosion resistant

Options

- Non-reset
- Subtractive
- Double shaft extensions
- Special mounting bases
- Weatherized versions
- 98WF - Measuring Wheel - 12" circumference

Specifications

<b>Figures:</b>	6 figures, white on black, 0.30" [7.6mm] high	<b>Shaft Extension:</b>	Right-hand or left-hand
<b>Reset:</b>	Knob or lock and key	<b>Shaft Diameter:</b>	0.25" [6.4mm]
<b>Speed:</b>	2,500 counts/minute or revolutions/minute, whichever is lower	<b>Ratio:</b>	1 count/revolution or 10 counts/revolution
<b>Rotation:</b>	Top-coming or top-going, to add. Will not subtract if rotation is reversed	<b>Operating Life:</b>	Beyond 100 million counts
		<b>Temp. Range:</b>	-15°F to +140°F [-26°C to +60°C]
		<b>Weight:</b>	18 oz. [510g]

Models	Description	Models	Description
11-2916	Left-hand, top-coming, 10 counts/revolution	21-2936	Right-hand, top-coming, 1 count/revolution
11-2936	Right-hand, top-coming, 10 counts/revolution	21-2946	Right-hand, top-going, 1 count/revolution
21-2916	Left-hand, top-coming, 1 count/revolution	22-2936	Right-hand, top-coming, 1 count/revolution, lock & key reset,
21-2926	Left-hand, top-going, 1 count/revolution		

Dimensions

Right - Hand Shaft

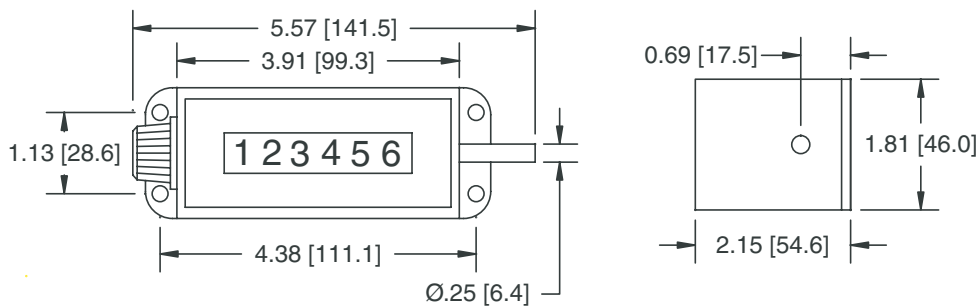

Applications

Winding equipment

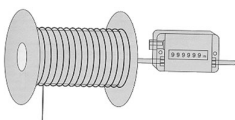

Spooling

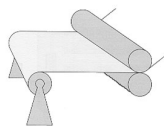

Positioning

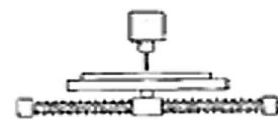



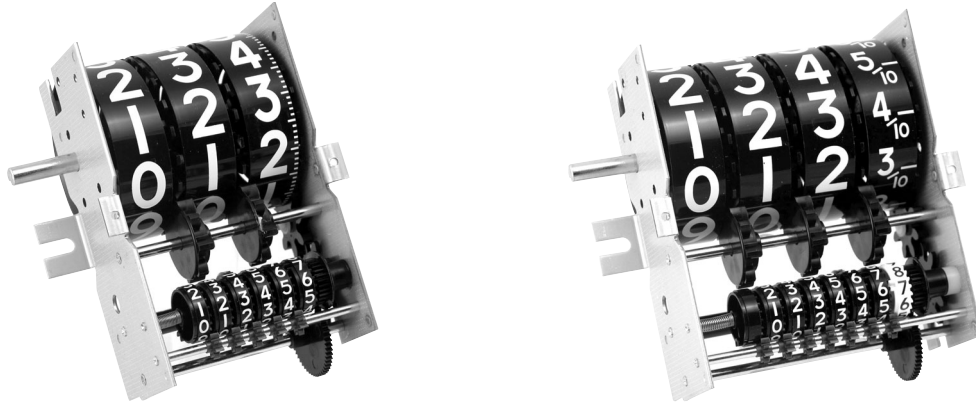

**Description**

The Model 41 is a 3-figure or 4-figure mechanical register and is used to display gallons or liters output from a dispenser or pump. The large figure display can be reset with the rotary reset shaft. A smaller, non-reset, mechanical totalizer is also included to record total product dispensed.

**Features**

- Large easy to read figures
- Time tested, reliable and durable
- Wide operating temperature range
- All non-corrosive parts
- Spring loaded totalizer is pre-settable
- No lubrication required

**Options**

- Gallons or liters
- Reset shaft configuration
- Reset shaft: right hand, left hand, or both

**Specifications**

**Figures:**

**Main Display:** 3 or 4 figures, white on black, 0.65" [16.5mm] high

**Totalizer:** 0.19" [5mm] white on black

**Reset:** Rotary reset. Reset knob supplied by customer

**Reset Shaft:** 0.25" [6.4mm] diameter

**Speed:**

40 gallons per/minute, 400 liters per/minute

**Operation Life:**

1 million gallons, 10 million liters

**Temp. Range:**

-40°F to +150°F [-40°C to +65°C]

**Weight:**

3-figure - 9oz [255g], 4-figure - 11oz [312g]

Models	Description	Models	Description
1-4103	3-figures, gallon display	2-4103	3-figures, liter display
2-4104	4-figures, gallon display	3-4104	4-figures, liter display

**Dimensions**

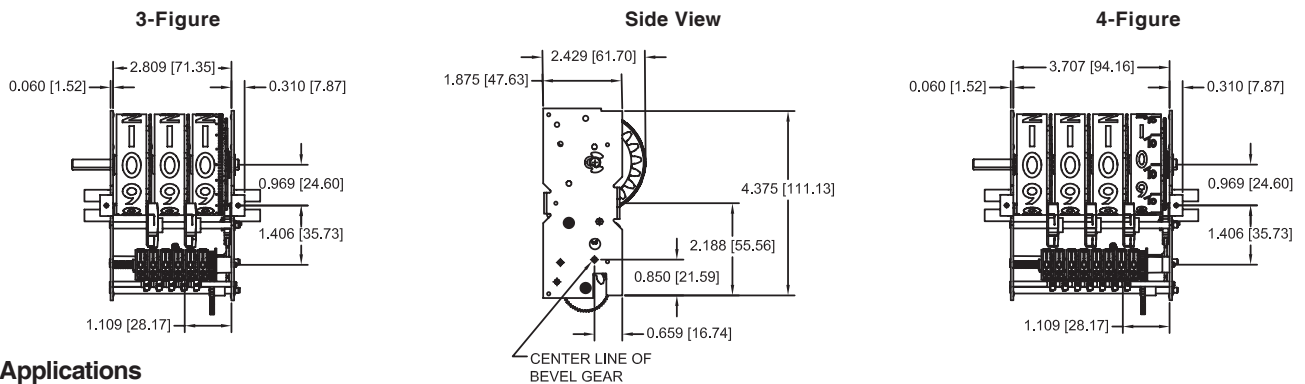

**Applications**

**Pumps and Flow Meters**





With Lever & Spring

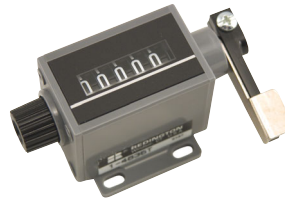

With Thumb Lever

Description

These 5 figure stroke counters are especially designed for limited space and high count life applications. The advanced drive system translates into exceptionally high operating speeds, extended operating life, for fast and accurate readings. Ideal for copiers, printing presses, cut-off machines, and piece-part counting applications. Also available with a thumb lever for use as a tally counter.

Features

- Compact size
- Reliability
- Low cost

Options

- Special levers
- 10011-001S - additional spring
- 10007-009S - lever and spring

Specifications

**Figures:** 5 figures, white on black, 0.19" [5mm] high  
**Reset:** Standard or large knob, non-reset  
**Speed:** 500 counts/minute  
**Rotation:** Top-coming or top-going  
**Count Stroke:** 40° Min. - 45° Max.

**Shaft Extension:** Right-hand or left-hand  
**Shaft Diameter:** 0.156" [4.0mm]  
**Operating Life:** Beyond 5 million counts  
**Temp. Range:** -15°F to +140°F [-25°C to +60°C]  
**Weight:** 2 oz. [57g]

Models	Description	Models	Description
<b>1-4615</b>	Left-hand, top-coming, standard reset knob	2-4615	Left-hand, top-coming, large reset knob
<b>1-4625</b>	Left-hand, top-going, standard reset knob	2-4625	Left-hand, top-going, large reset knob
<b>1-4635</b>	Right-hand, top-coming, standard reset knob	2-4635	Right-hand, top-coming, large reset knob
<b>1-4645</b>	Right-hand, top-going, standard reset knob	2-4645	Right-hand, top-going, large reset knob
<b>1-4635T</b>	Right-hand, top-coming, std. reset knob, with thumb lever	5-4645	Right-hand, top-going, non-reset

\* Items in bold are normally in factory stock.

Dimensions

Right - Hand Shaft

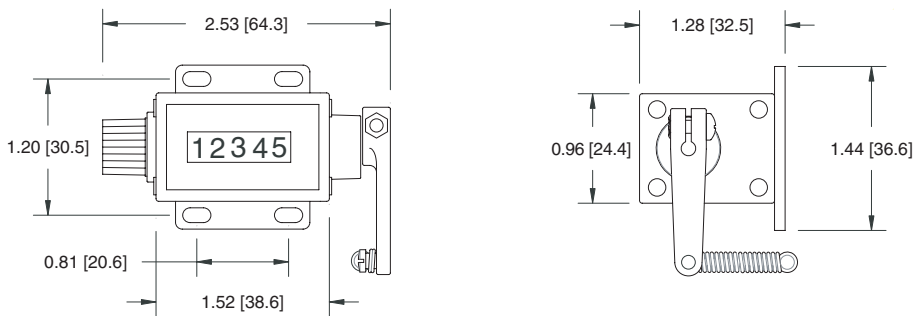

Mounting holes: 0.13" x 0.24" [3.3 x 6.1mm] slots

Applications

Copiers



Printing presses

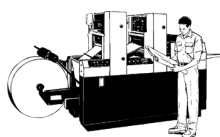

Farm equipment

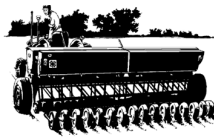

Piece-part counting

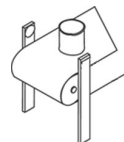

Cut-off machines

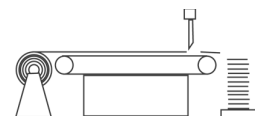



**Description**

These rugged revolution counters are completely sealed, tamper resistant, and maintenance-free. They can be mounted on a rotating shaft or wheel. Adds in either direction, and records revolutions, miles, kilometers, or acres. They are used on material handling equipment, farm machinery, rapid transit vehicles, street sweepers, golf carts, and construction equipment.

**Features**

- Sealed
- Tamper resistant
- Bi-directional

**Options**

- Face plate
- Custom calibrations

**Specifications**

**Figures:** 7 figures, 0.19" [5mm] high  
**Temp. Range:** -50°F to +180°F [-45°C to +82°C]  
**Weight:** 1.5 Lbs. [0.7kg]

Models	Description	Models	Description
750-0002	Reading x 10 = Total Revolutions (Revolutions)	750-0114	Reading x 100 = Revolutions (Revolutions)
750-0007	(9.5L - 15) x 15' (Acres)	750-0156	798 Revolutions per Acre (Acres)
750-0016	364 Revolutions per Acre (Acres)		

Consult factory for a counter to meet your specific needs.

**Dimensions**

**Hubodometer**

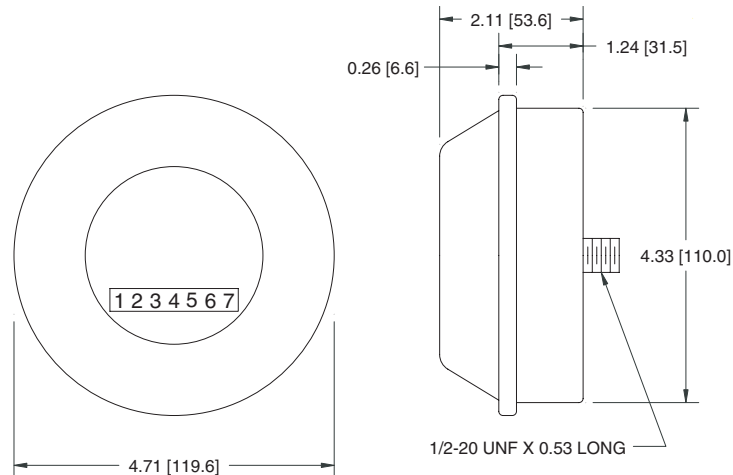

**Applications**

Rapid transit vehicles



Farm machinery



Golf carts



Construction equipment





Description

This 3 or 4 figure stroke counter with operating lever, spring assembly and reset knob, requires minimal space for mounting plus offers a high count rate and long life. The Model PCU can be reset during operation without damage. All PCU's are designed to minimize internal contamination, making them an excellent choice for outdoor use.

Features

- 3 or 4 figure
- Compact size
- Suitable for outdoor use

Options

- Non-reset
- Large reset knob

Specifications

**Figures:** 3 or 4 figures, white on black, 0.19" [5mm] high  
**Reset:** Knob  
**Speed:** 600 counts/minute  
**Rotation:** Top-coming or top-going  
**Count Stroke:** 40° Min. - 45° Max.

**Shaft Extension:** Right-hand or left-hand  
**Shaft Diameter:** 0.156" [4mm]  
**Operating Life:** Beyond 50 million counts  
**Temp. Range:** -15°F to +140°F [-26°C to +60°C]  
**Weight:** 2 oz. [57g]

Models

Description

- 1-PCU-13 Left-hand, top-coming, 3 figure
- 1-PCU-33 Right-hand, top-coming, 3 figure
- 1-PCU-33T Right-hand, top-coming, 3 figure, with thumb lever
- 1-PCU-43 Right-hand, top-going, 3 figure

Models

Description

- 1-PCU-14 Left-hand, top-coming, 4 figure
- 1-PCU-24 Left-hand, top-going, 4 figure
- 1-PCU-34 Right-hand, top-coming, 4 figure
- 1-PCU-44 Right-hand, top-going, 4 figure

Dimensions

1-PCU-13

1-PCU-14

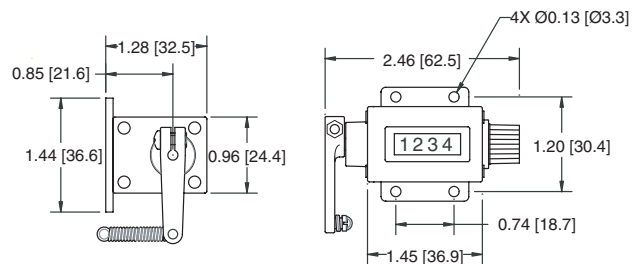
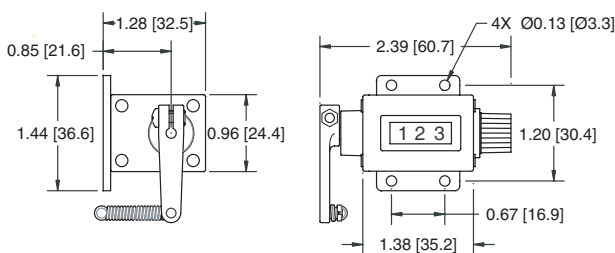

Applications

Secondary Machines



Shears



Farm Machinery





**Description**

Designed for use in a wide variety of production, batching and packaging applications. These 4 or 6 figure electromechanical predetermining counters count down from a preset number and activate a SPDT switch. Convenient preset controls and built-in manual reset with guard are standard. A surge absorbing circuit protects against damage due to voltage spikes. Heavy duty bail mount secures counter in place.

**Features**

- 4 or 6 figures
- Heavy duty mount
- SPDT switch

**Options**

- Voltages

**Specifications**

**Figures:** 4 or 6 figures, white on black, 0.16" [4mm] high  
**Reset:** Manual, or electric reset (min. 100ms - on, 1min - off)  
**Speed:** 600 counts/minute (min. 50ms - on, 50ms - off)  
**Voltages:** 115VAC, 24VDC  
 (+/-10%, but not to exceed 10 volts)  
**Power:** 5.5 watts count, 20 watts reset (nominal)  
**Mounting:** Bail

**Termination:** Screw type  
**Operating Life:** Beyond 100 million counts  
**Temp. Range:** -15°F to +140°F [-26°C to + 60°C]  
**Output Switch:** SPDT 5 Amp. @ 250 VAC resistive  
**Output Duration:** Until reset  
**Approvals:** UL Recognized, CE Compliant  
**Weight:** 10 oz. [284g]

**Models Description**

**B2-5804** 115VAC, 4 figure, manual reset  
**B2-5804/E2** 115VAC, 4 figure, 115VAC electric reset  
**B8-5804** 24VDC, 4 figure, manual reset  
**B8-5804/E8** 24VDC, 4 figure, 24VDC electric reset

**Models Description**

**B2-5806** 115VAC, 6 figure, manual reset  
**B2-5806/E2** 115VAC, 6 figure, 115VAC electric reset  
**B8-5806** 24VDC, 6 figure, manual reset  
**B8-5806/E2** 24VDC, 6 figure, 115VAC electric reset

\* Items in bold are normally in factory stock.

**Dimensions**

**Bail Mount**

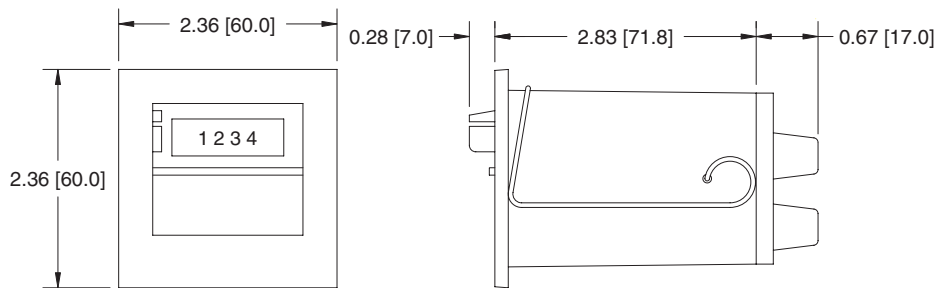

Panel cutout: 2.17" x 2.17" [55.1 x 55.1]

**Applications**

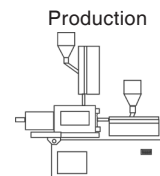
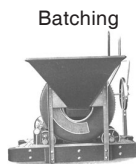
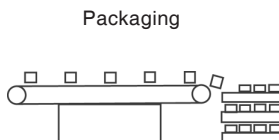



Description

The Redington Model 33 line of LCD hour meters provides a large display, 7mm high figures, in the industry size housings. The hour meters are available in a variety of mountings: 2-hole rectangular, 3-hole round, flush-round and flush-rectangular. Voltage operating ranges are 10-277 VDC AND 20-277VAC 50/60Hz. All models are totally sealed from moisture and dirt and conform to NEMA 4 & 4X specifications when mounted with the optional gasket. Their rugged construction makes them ideal replacements for current hour meters. Units have polarized LCD for high visibility in sunlight.

Features

- AC or DC voltage input in the same unit
- Totally sealed from moisture and dirt
- Run indicator-blinking decimal point
- Always on display
- Compact depth
- AC Voltage input is not frequency sensitive
- Clip retainer mount or screws (supplied)

Options

- Custom logos and bezels
- Terminations
- Remote reset - dry contact with 6" wire leads
- Gaskets
  - 5003-002S gasket for 2-hole mount
  - 5003-003S gasket for flush-rectangular mount
  - 5003-004S gasket for flush-round mount
  - 5003-005S gasket for 3-hole round mount

Specifications

**Display:** LCD with large 0.28" [7mm] high figures, black on light background

**Run Indicator:** Blinking decimal point

**Quartz Accuracy:** 0.02% over entire voltage & temperature range

**Records & Displays:** 6 digit (99999.9)

**Inputs:** 10 to 277VDC AND 20-277VAC-50/60Hz  
 Vih\* 20VAC or 10VDC minimum  
 Vil\* 3VAC or 3VDC maximum

**Battery Life:** 7+ years

**Shock:** 44 to 55g's, SAE J1378

**Vibration:** 20 g @ 10 to 80 Hz, SAE J1378

**Humidity:** 95% SAE J1378

**Operating Temperature:** -40°F to +185°F [-40°C to +85°C]

**Sealing:** Totally sealed, panel gaskets-NEMA 4 & 4X CE compliant

**Agency Approvals:** UL/cUL recognized (file# ELIY2.E36690)  
 0.250" [6.4mm] spades  
 Optional - dry contact with 6" wire leads  
 Polymer (black)

**Termination:** 1oz [28g]

**Reset:** Alternator load dump: 150V

**Case Material:** EMI(Electromagnetic Interference): +400V @ 500Hz inductive switching and reverse polarity

**Weight:**

**Protection Against:**

\* Vih is the input high voltage. This is specified as the minimum input voltage that the Model 33 will recognize as a high level.  
 Vil is the input low voltage. This is specified as the maximum input voltage that the Model 33 will recognize as a low level.

Note: When interfacing the Model 33 with a Solid State Relay or AC Sensor, the leakage current needs to be considered. Contact the factory or see the application note at [www.redingtoncounters.com](http://www.redingtoncounters.com) for further information.

Models	Description	Models	Description
3311-0000	2-Hole Rect., 10-277 VDC AND 20-277VAC	3311-0010	2-Hole Rect., 10-277 VDC AND 20-277VAC, remote reset
3311-1000	3-Hole Round, 10-277 VDC AND 20-277VAC	3311-1010	3-Hole Round, 10-277 VDC AND 20-277VAC, remote reset
3311-2000	Flush Rect., 10-277 VDC AND 20-277VAC	3311-2010	Flush Rect., 10-277 VDC AND 20-277VAC, remote reset
3311-3000	Flush-Round, 10-277 VDC AND 20-277VAC	3311-3010	Flush-Round, 10-277 VDC AND 20-277VAC, remote reset

All parts are normally in factory stock.



Dimensions

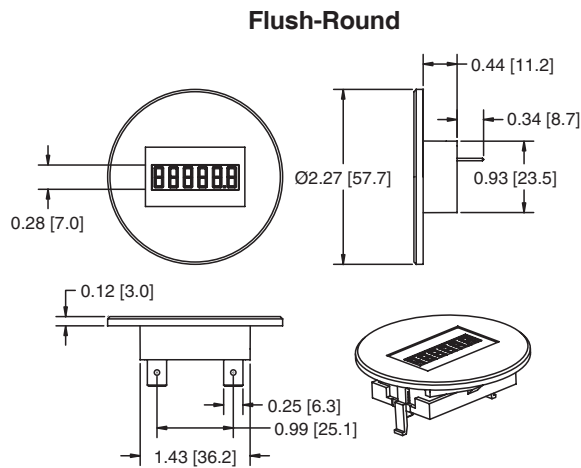
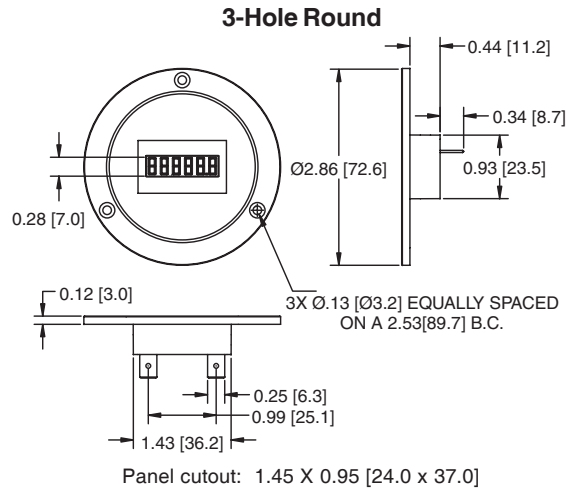
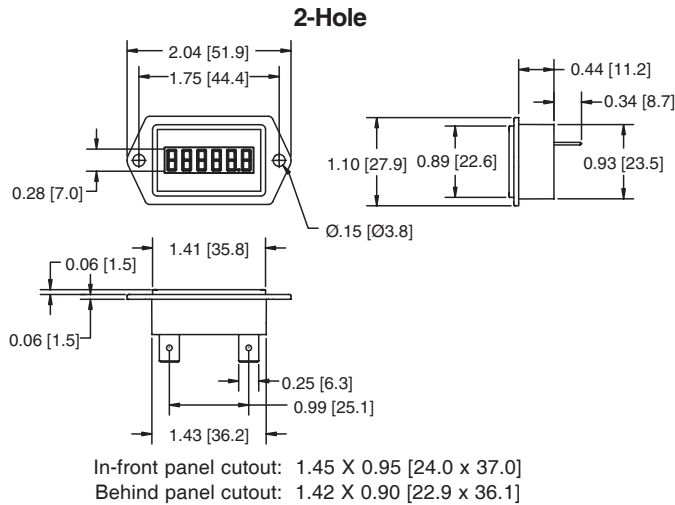

Panel cutout: 1.45 X 0.95 [24.0 x 37.0]  
Maximum panel thickness: 0.15 [3.8]

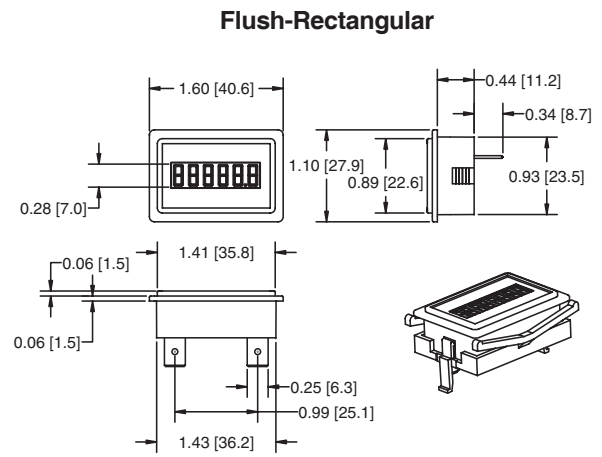

Panel cutout: 1.45 X 0.95 [24.0 x 37.0]  
Maximum panel thickness: 0.15 [3.8]

Applications

Agricultural Equipment



Medical Devices



Pressure Washers



Sweepers



Construction Equipment



Marine Applications



Generators

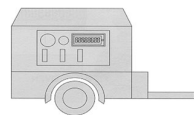

Office Equipment



Test Equipment



Boom Lifts



Compressors

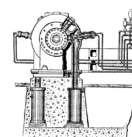

Utility Vehicles





Description

The Redington Model 51 line of 5 figure LCD meters provides a large display in the industry size package. A choice of mountings, Round, 2 Hole Dual, Mini Rectangular or Surface Mount. A custom microprocessor, capable of being programmed to create an almost infinite matrix of models is ideally suited for OEM applications. Available in 3 inputs, DC, AC or Inductive. Maintenance Meters are offered with a "Redi-Alert" to alert users when service is due. Not only does the display flash to get attention, but it displays specific maintenance service needs to be done. Units have Polarized LCD for high visibility in sunlight. Servicing equipment on time is critical to efficient operation and long equipment life. That is why you should consider Redington's "Redi-Alert" meters. Redi-Alert offers two independent alarms (both fully programmable) to alert users when service is due. Alarms are fully automatic; coming on and shutting off at times determined by the OEM.

Features

- Totally sealed from moisture and dirt
- Fits in existing panel openings
- "Redi-Alert" for preventive maintenance
- Icons for specific maintenance needs
- Tachometer/Hour Meter versions
- Automatic rollover
- Hour glass symbol appears & flashes on/off to indicate running time
- Various voltage inputs
- Short depth
- Always on display

Options

- Various voltage inputs
- Alarm outputs: audible or visual (external voltage required)
- Custom logos & bezels
- Terminations: stud, wire, screw, or blade
- Alternator and filtered versions
- Key Kancel (alarm reset via external key or wand)

Specifications

**Display:** Large 0.20" [5mm] LCD, black on light background

**Records & Displays:** 5 digits (9999.9)

**Resolution:** 0.1 hours

**Quartz Accuracy:** 0.02% over entire voltage & temp. range

**Inputs:** 8-32 VDC, 32-277 VAC-50/60HZ

**Operating Temperature:** -40°F to +160°F [-40°C to +71°C]

**Battery Life:** 15 years

**Current Consumption:** 1 mA (for multi-range voltages 1 mA applies to lower voltage)

**Approvals:** AC-UL/cUL Recognized, CE Compliant

**Protection Against:** Transient voltage, inductive switching, reverse polarity, frequency variations

**Alternator Load Dump:** 150 V

**Shock:** SAE J1378 55g

**Vibration:** SAE J1378 20g

**Humidity:** SAE J1378 95% RH

**Termination:** Panel mount standard terminals, 0.250 male blade (s), surface mount- wire lead

**Case Material:** ABS, black, 100% epoxy filled

**Weight:** 1 oz. [28g]

Models Description

Models	Description
<b>DC Models</b>	
<b>5120-1000</b>	Panel Mount, Round, 8-32 VDC, Hours & 1/10's
<b>5120-1100</b>	Panel Mount, Mini, 8-32 VDC, Hours & 1/10's
<b>5120-1200</b>	Panel Mount, 2 Hole, 8-32 VDC, Hours & 1/10's
<b>AC Models</b>	
<b>5120-2000</b>	Panel Mount, Round, 32-277VAC, 50/60 Hz, Hours & 1/10's
<b>5120-2100</b>	Panel Mount, Mini, 32-277 VAC, 50/60 Hz, Hours & 1/10's
<b>5120-2200</b>	Panel Mount, 2 Hole, 32-277 VAC, 50/60 Hz, Hours & 1/10's

Models Description

Models	Description
<b>Inductive Models</b>	
<b>5120-0000</b>	Panel Mount, Round, Inductive, Hours
<b>5120-0100</b>	Panel Mount, Mini, Inductive, Hours
<b>5120-0200</b>	Panel Mount, 2 Hole, Inductive, Hours
<b>5140-0000</b>	Panel Mount, Round, Inductive, Hours & 1:1Tach
<b>5140-0100</b>	Panel Mount, Mini, Inductive, Hours & 1:1Tach.
<b>5140-0200</b>	Panel Mount, 2 Hole, Inductive, Hours & 1:1Tach.
<b>5120-0310</b>	Surface Mount, Inductive, Hours
<b>5140-0311</b>	Surface Mount, Inductive, Hours w/1:1Tach. Change oil Alert @ 25hr./2 hr. flash Lube Alert @ 25hr./2 hr. flash
<b>5140-0312</b>	Surface Mount, Inductive, Hours w/1:1Tach. Change oil Alert @ 100hr./4 hr. flash Lube Alert @ 25 1hr./2 hr. flash

\* Items in bold are normally in factory stock.





Alarm Specifications

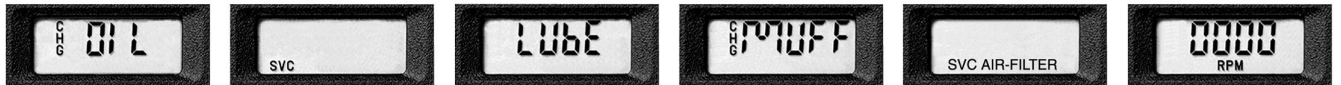

Alarms programmable for your applications

ALARM # 1

Programmable for a "first time" (break in service) or a normal recurring service interval.

ALARM # 2

Same as alarm # 1, but without the "first time" interval.

ALARM/FLASH DURATION

OEM's specify the service interval and flash duration for each alarm. Flash duration is the amount of time in hours that the specified icon flashes before and after the service interval.

ALARM RESET

The standard alarm alert is fully automatic with no operator interface necessary. The alarm simply flashes the specified icon for the duration called out by the OEM. Controlled reset options are available for a higher level of security. Contact factory for additional information.

MAINTENANCE METER ALARM SPECIFICATIONS

ALARM #1

1st time service interval range (2 to 99 hrs. occurs only once)

Normal service interval range: 2 to 999 hrs. (Recurring)

Flash duration: 1 to 99 hrs. (Time flashing before & after service interval)

Available icons: CHG OIL, LUBE, CHG MUFF, SVC-AIR FILTER, SVC-Lower left/right side of display

ALARM #2

Normal service interval range: 2 to 999 hrs. (Recurring)

Flash duration: 1 to 99 hrs. (Time flashing before & after service interval)

Available icons: CHG OIL, LUBE, CHG MUFF, SVC-AIR FILTER, SVC-Lower left/right side of display

Alarms flash specified icon 4 seconds then flash hour 4 seconds throughout alarm duration.

Dimensions

2 Hole Dual Mount

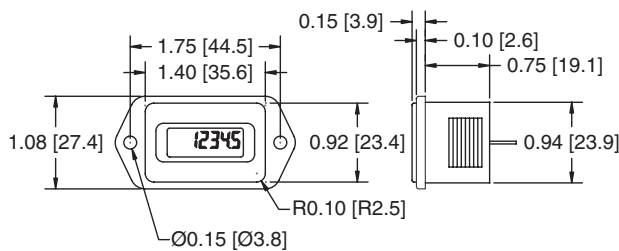

Above panel cutout 1.46 x 0.95 [37.1 x 24.1] opening
Behind panel cutout 1.41 x 0.93 [35.8 x 23.6] opening

Round

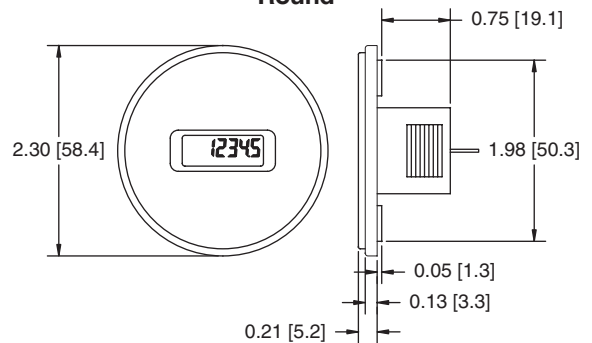

Spring clip retainer, Fast installation
Panel cutout 2.0 [50.8] diameter

Surface Mount

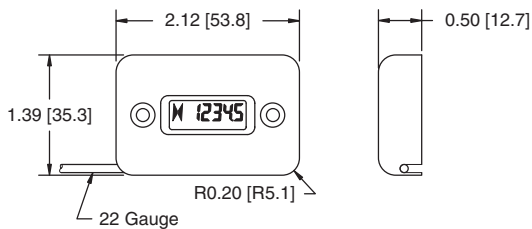

Mounting holes are 1 1/2" [38.1] spacing
Hole Diameter is 1/8" [3.2]

Mini Rectangular

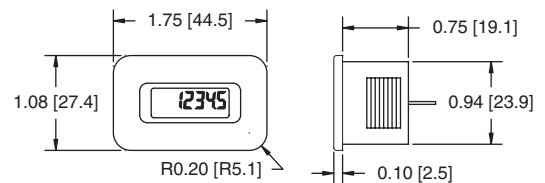

Compact Bezel Design, Spring clip retainer, Fast installation, Panel cutout 1.46 x 0.95 [37.1 x 24.1] opening.

Applications

Construction Equipment



Medical Devices



Generators

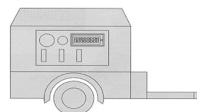

Marine Applications



Garden Tractors



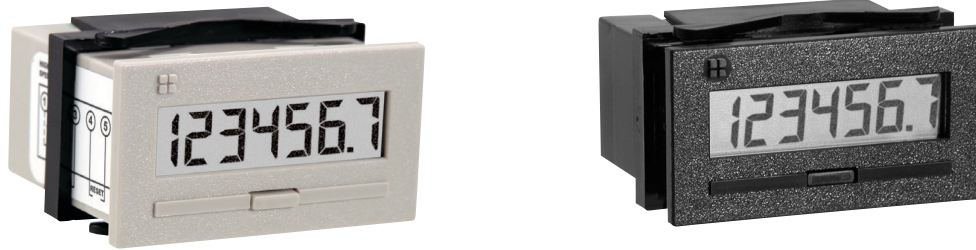

Description

The Model 53 Hour Meter with 7 LCD digits, 999999.9, and internal lithium battery, is ideal for applications requiring time accumulation for maintenance scheduling, warranty monitoring, lease time or fee computation. Applications include test equipment, panel builders, mobile equipment and medical devices. A choice of time ranges, in hours, minutes or seconds provides the user with a wide choice of recording increments.

Features

- Lithium battery
- Choice of manual reset, remote reset or non-reset
- Switch (no-voltage), 3-30VDC, 20-250VAC/VDC

Options

- Termination
- Case color
- Private labeling
- Mounting adapter plates
- 5003-001S - gasket
- Low AC voltage (4-30 VAC)

Specifications

**Figures:** 7 LCD figures, 0.32" [8mm] high  
**Reset:** Remote, manual, and non-reset  
**Inputs:** Switch (no-voltage), 3-30VDC, 20-250VAC/VDC (50/60Hz)  
 Vih\* 20VAC/3VDC minimum  
 Vil\* 3VAC/1VDC maximum  
**Power:** Self-powered (internal lithium battery)  
**Mounting:** Panel with clip  
**Terminations:** Terminal block, or connector - 8" [200mm] wire leads  
**Weight:** 2 oz. [57g]  
**Battery Life:** ~20years  
**Accuracy:** Quartz accuracy (better than 0.01%)  
**Approvals:** UL Recognized, CSA Certified, CE Compliant

**Temperature**  
**Operating:** -4°F to +140°F [-20°C to +60°C]  
**Storage:** -40°F to +165°F [-40°C to +75°C]  
**Humidity:** 0 to 95% RH, non-condensing  
**Vibration**  
**Operating:** 10 to 55Hz, 0.01" [0.25mm] double amplitude  
**Non-Operating:** 10 to 55Hz, 0.03" [0.75mm] double amplitude  
**Shock**  
**Operating:** 10G  
**Non-Operating:** 30G  
**Dielectric:** 1000VAC 50/60Hz for 1 minute

Note: When interfacing the Model 53 with a Solid State Relay or AC Sensor, the leakage current need to be considered. Contact the factory or see the application note at [www.redingtoncounters.com](http://www.redingtoncounters.com) for further information.

Models

Part#	Function			Reset			Input			Terminations		Color	
	hours	min.	sec.	remote	none	manual	switch	3-30VDC	20-250VAC/VDC	term. block	8" wire leads	tan	black
<b>5320-0000</b>	X			X			X			X		X	
5320-0001	X			X			X			X			X
5321-0000		X		X			X			X		X	
5321-0001		X		X			X			X			X
5322-0000			X	X			X			X		X	
5322-0001			X	X			X			X			X
<b>5320-0100</b>	X			X		X	X			X		X	
5320-0101	X			X		X	X			X			X
<b>5320-1000</b>	X			X				X		X		X	
5320-1001	X			X				X		X			X
5320-1010	X			X				X			X	X	
5320-1011	X			X				X			X		X
<b>5320-1100</b>	X			X		X		X		X		X	
<b>5320-2000</b>	X			X					X	X		X	
5320-2001	X			X					X	X			X
5320-2200	X				X				X	X		X	
5320-2201	X				X				X	X			X
<b>5320-2100</b>	X			X		X			X	X		X	

\* Items in bold are normally in factory stock.



Dimensions

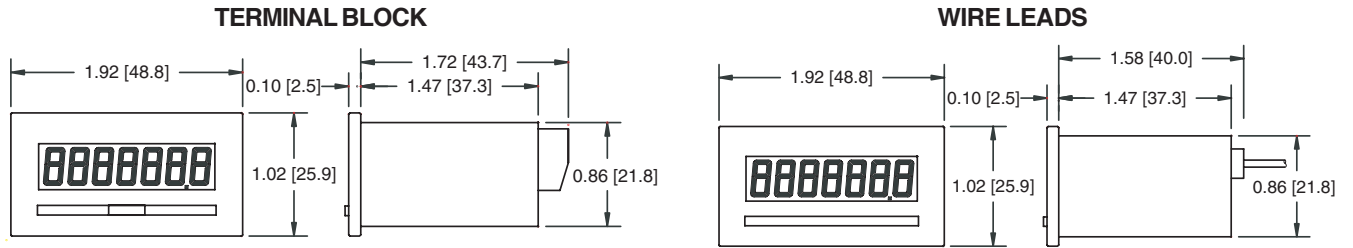

Operating Instructions

MOUNTING:

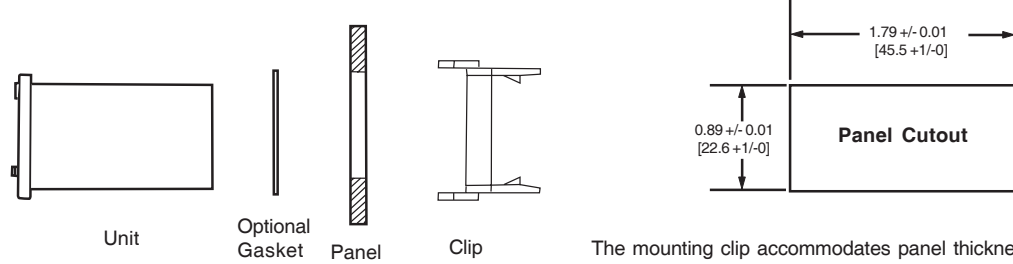

The mounting clip accommodates panel thicknesses up to 1/4" [6.4mm].

Panel adapter plates are available in flush and 2 hole mount to fit various panel cutouts. Consult the factory for availability.

WIRING:

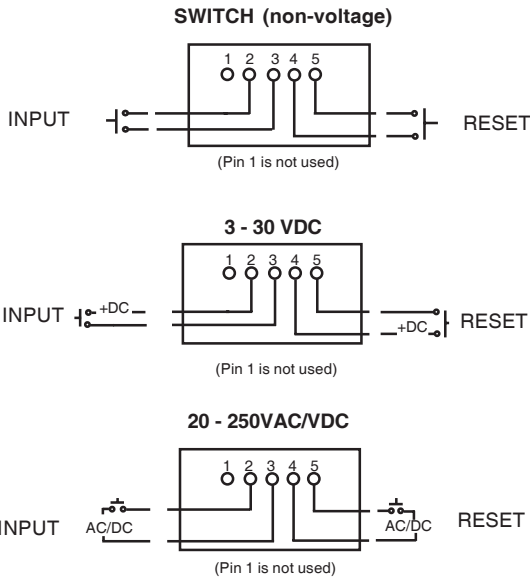

Color code for the 8" [203mm] lead wires (24AWG) are:

- 1 - Yellow
- 2 - Blue
- 3 - Black
- 4 - Violet
- 5 - Gray

Terminal block will accept wire sizes from 14 to 24AWG.

3 - 30VDC units are protected for transient voltages up to 50 volts with pulse widths of up to 1 second at a 1% duty cycle (including reverse polarity).

The operating AC frequency range is 40 to 400Hz.

NOTES:

All resettable hour meters can be reset by a pulse with a minimum duration of 6 milliseconds.

SPECIAL WIRING OPTION

There is an internal connection between pin 3 and pin 5, a single wire can be used by connecting it to either pin 3 or pin 5. This option **does not** apply for units with input of 20 - 250VAC/VDC or manual reset enable.

OPTIONAL INPUTS:

Optional control circuitry (such as transistors) may be used as inputs provided that such circuitry provides the required parameters of the model used.

Applications

Medical Equipment



Test Equipment



Office Equipment





Description

The Model 55 LCD hour meters and counters offer a flexible choice for basic hour meter or counter function. Three variations of cases make the Model 55 flexible for your installation requirements. Because all information is saved in an internal EEPROM memory, no battery is required. A broad range of AC or DC input voltages make the Model 55 a versatile product for most applications. Two operating versions of the hour meter and three operating versions of the counter are offered. These include hour meters that display hours to resolutions of 1/100th or 1/10th of an hours and counters that operate with maximum input rates of 30 Hz or 200 Hz for DC inputs and 10 Hz for AC inputs. The Model 55 includes models with reset options that include remote reset, manual and remote reset, and non-reset. A model designed to mount to a printed circuit board is available upon request.

Features

- Manual, remote or non-reset
- EEPROM for memory (no battery)
- AC or DC input voltages
- 3 housing configurations
- 1/10th or 1/100th hours indication
- IP 65 front panel, without reset button
- Display hours or counts
- Choice of count frequency

Options

- 1/10th or 1/100th hour indication, or counts
- Reset type
- Case configuration
- Termination
- Count speed





Specifications

<b>Figures:</b>	7 LCD figures, 0.28" [7mm] high	<b>Operating Temp:</b>	-22 °F to +158 °F [-30°C to +70°C]
<b>Quartz Accuracy:</b>	0.01%	<b>Humidity:</b>	0 to 95% RH, non-condensing
<b>Reset:</b>	Manual and remote, non-reset and remote only	<b>Protection:</b>	Without reset button-IP 65, gasket supplied, With reset button-IP54
<b>Input Voltage:</b>	12/24 VDC ±25%	<b>EMC:</b>	EN 55011, EN 50082-2
	115-240 VAC ±10% 50/60 Hz	<b>Vibration:</b>	1 g (10-500 Hz) IEC 68-2-34
<b>Special Voltage:</b>	24 VAC/DC ±10%, 24-48 VDC ±25%	<b>Shock:</b>	30 g (18 msec.) IEC 68-2-27
<b>Current:</b>	12-24 VDC & 24-48 VDC/2-4 mA		25 g (6 msec.) IEC 68-2-29
	24 VAC/DC/2 mA	<b>Max Count Speed:</b>	30, 200 Hz DC or (10 Hz AC or AC/DC)
	115-240 VAC/7- 15 mA	<b>Memory:</b>	EEPROM (no battery)
<b>Mounting:</b>	Retaining clip	<b>Case Material:</b>	Black, ABS plastic with glass lens on round model only
<b>Terminations:</b>	1/4" spade or screw terminals	<b>Weight:</b>	2 oz. [57g]
<b>Approvals:</b>	UL Recognized, CE Compliant		

Models Description

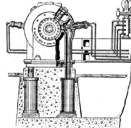
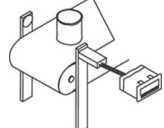
For Details on Models and Descriptions, see the Ordering Information section.

Applications

<p>Test equipment</p> 	<p>Compressors</p> 	<p>Piece count</p> 
<p>Packaging machinery</p> 	<p>Panel builders</p> 	<p>Medical devices</p> 



Dimensions

Round

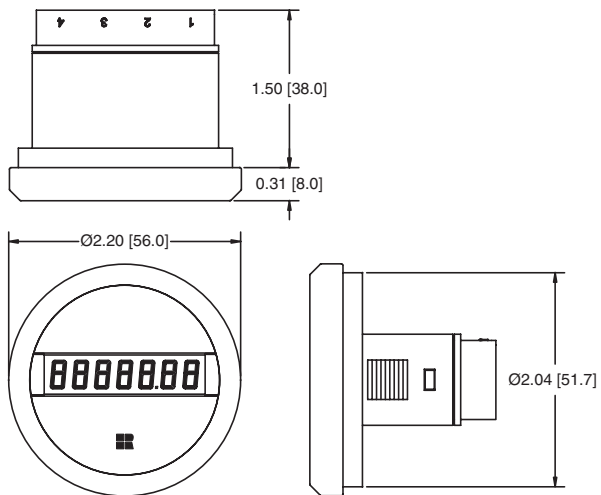

PANEL CUT OUT: Ø2.055 [52.2]

Square

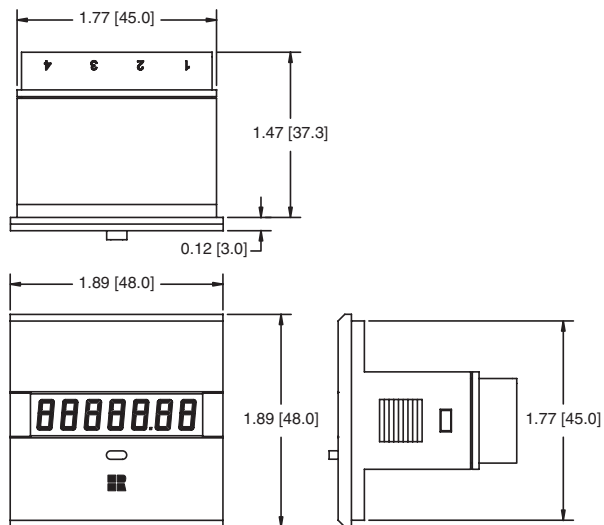

PANEL CUT OUT: 1.78 [45.2] SQUARE

Rectangular

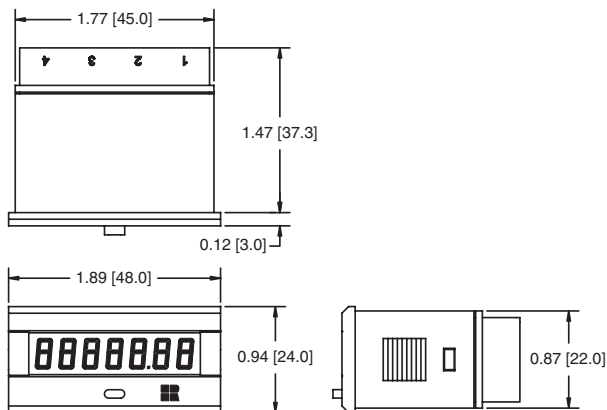

PANEL CUT OUT: .876 [22.2] X 1.772 [45]

Mounting Clip

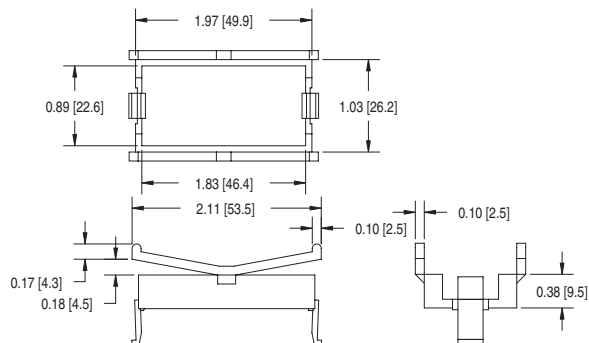

Maximum Panel Thickness for all units: 0.15" [6.4mm]

Wiring Diagram

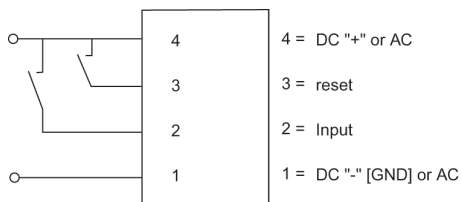





**Description**

The Redington Model 56 family of LCD indicators offers a variety of options to fulfill your count/hour meter requirements. This indicator can display hours, counts or both with a single-line shared display. You decide which value should be displayed permanently and which one will be in the background. The background indication will appear for approximately 10 seconds every time you apply power to the meter.

The Model 56 family offers you many features that are set at the factory at your request. These features include, input voltages, maximum count speeds or minimum hour meter indication times, connector terminations, reset configurations, a Redi-Alert Service Interval feature, prewarn, and input scaling.

The Model 56 family can be ordered to accommodate any of a number of AC or DC input voltages and reset configurations. The counter can be ordered for maximum input count speeds of 10 Hz for AC or AC/DC voltages and 30 Hz or 200 Hz for DC voltages. The hour meter can be ordered to display time intervals of 1/100<sup>th</sup> or 1/10<sup>th</sup> of hours. When using a counter and an hour meter in combination, the counter will count the number of input pulses while the hour meter will record the total duration of the input pulses.

The Redi-Alert Service Interval feature notifies operators of service requirements when service intervals are a function of the number of events or time. If a Redi-Alert Service Interval is specified, the display will show the count (or time) remaining until the service interval is reached. The Redi-Alert Service Interval feature can be considered to be a down-counter (or down-timer) since the count (or time) that is displayed shows what remains until service is required. When the Redi-Alert Service Interval gets to zero, the indicator will flash the display. If the Redi-Alert Service Interval is not reset, the indicator will continue to operate, and the display will show negative counts (or time) indicating how far the system has gone past the service interval. If the prewarn feature is included, the display will begin flashing when the prewarn count (or time) is reached. When the Service Interval is in the background, it will come to the foreground when it reaches the service interval or the prewarn. Resetting the indicator resets the Service Interval to its specified setting and returns the Service Interval to the background.

You can configure your Model 56 meter using the Ordering Information sheet.

**Features**

- Display hours or hours and counts
- "Redi-Alert" for service hours or counts
- Manual, remote or non-reset
- EEPROM for memory (no battery)
- Divider/multiplier on inputs
- AC or DC input voltage
- 3 housing configurations
- Choice of 1/100<sup>th</sup> or 1/10<sup>th</sup> hours (specify)

**Options**

- Input scaling
- Input frequency
- Reset type
- Indication of time/count
- Wide selection of input voltage
- Service "Redi-Alert"

**Specifications**

<b>Display:</b>	7 digit, 0.28 [7mm], LCD, 1 display	<b>Memory:</b>	EEPROM (no battery)
<b>Quartz Accuracy:</b>	0.01%	<b>Approvals:</b>	UL Recognized, CE Compliant
<b>Input Voltage:</b>	12/24 VDC/ ±25% 115-240 VAC 50/60 Hz/±10%	<b>Mounting:</b>	Retaining clip
<b>Special Voltages:</b>	24-48 VDC/±25% 24 VAC 50/60 Hz/VDC/±10%	<b>Electrical Connection:</b>	1/4" [6.4mm] spade or screw terminals
<b>Current Consumption:</b>	12-24 VDC & 24-48 VDC/2-4 mA 24 VAC/VDC/2 mA 115-240 VAC/7-15 mA	<b>Case Material:</b>	Black, ABS plastic with glass lens on round model only
<b>Protection:</b>	Without reset button-IP 65, gasket supplied, with reset button-IP54	<b>Reset:</b>	Manual and remote, non-reset and remote only No manual reset for round model
<b>EMC:</b>	EN 55011, EN 50082-2	<b>Operating Temperature:</b>	-22°F to +158°F [-30°C to +70°C]
<b>Vibration:</b>	1 g (10-500) IEC 68-2-34	<b>Weight:</b>	2 oz [57g]
<b>Shock:</b>	30 g (18 msec.) IEC 68-2-27 25 g (6 msec.) IEC 68-2-29	<b>Service Alert:</b>	Factory set - one "Redi-Alert", 4 digits
<b>Max. Count Speed:</b>	30, 200Hz DC or (10 Hz AC or AC/DC) (specify)	<b>Input Scaling:</b>	Factory set, 4 digits
		<b>Prewarn Signal:</b>	Factory set, 4 digits



Models Description

For Details on Models and Descriptions, see the Ordering Information section.

Dimensions

Round

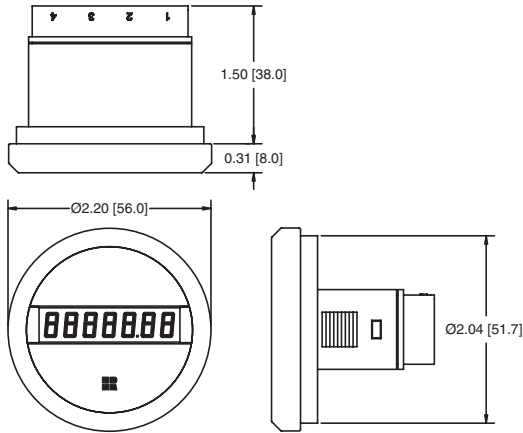

PANEL CUT OUT: Ø2.055 [52.2]

Square

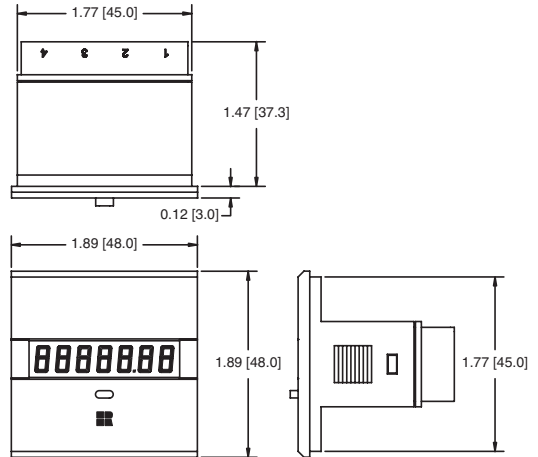

PANEL CUT OUT: 1.78 [45.2] SQUARE

Rectangular

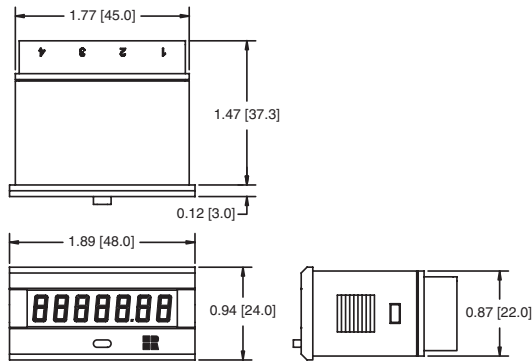

PANEL CUT OUT: .876 [22.2] X 1.772 [45]

Mounting Clip

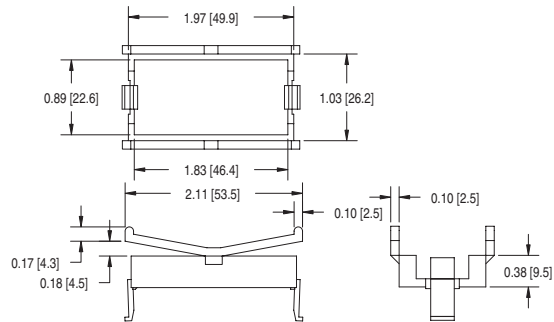

Maximum Panel Thickness for all units: 0.15" [6.4mm]

Wiring Diagram

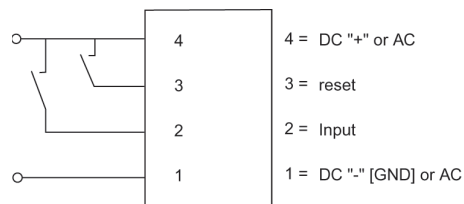

Applications

Test Equipment



Packaging Machinery

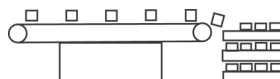

Medical Devices







Ordering Information

FUNCTION	HOUSING DIMENSIONS			NOTES
	1 X 2 INCH	2 X 2 INCH	ROUND 2.2 INCH	
HM WITH HM (bg)*	5600	5601	5602	Only HM is resettable
C WITH C (bg)*	5610	5611	5612	Only C is resettable
HM WITH C (bg)*	5620	5621	5622	Both are resettable
C WITH HM (bg)*	5630	5631	5632	Both are resettable
HM WITH SHM (bg)*	5640	5641	5642	Only SHM (bg) is resettable
C WITH SC (bg)*	5650	5651	5652	Only SC (bg) is resettable
SHM WITH HM (bg)*	5660	5661	5662	Only SHM is resettable
SC WITH C (bg)*	5670	5671	5672	Only SC is resettable

\*HM= Hour Meter \*C= Counter \*bg= Background \*SHM= Service Hour Meter \*SC= Service Counter

Note: The counter display is updated on the trailing edge of the input signal

Model 56 Specification Sheet

Company: \_\_\_\_\_ Phone: \_\_\_\_\_  
 Address: \_\_\_\_\_ Fax: \_\_\_\_\_  
 Contact: \_\_\_\_\_ Email: \_\_\_\_\_  
 Date: \_\_\_\_\_

Model No. \_\_\_\_\_ (4 digits) SELECTED FROM ABOVE TABLE .

Input Voltage: (check only 1)

- 12-24 VDC
- 115-240 VAC 50/60 Hz
- Special voltages available, consult factory.

Indication of time for Hour Meter: (check only 1)

- 1/100<sup>th</sup>
- 1/10<sup>th</sup>

Max. counting frequency for Counter: (check only 1)

- 30 Hz (DC)
- 200 Hz (DC)
- 10 Hz @ (AC) or (AC/DC)

Termination : (check only 1)

- 1/4" spade
- screw terminals

Reset Types: (check only 1)

- non-reset
- remote reset
- remote and manual reset (No manual reset for 2.2 " Round Model)

Service Interval: (optional)

- "Redi-Alert" : \_\_\_\_\_ (4 digits max)
- Prewarn : \_\_\_\_\_ (4 digits max)

Input scaling: (optional - check only 1)

- Divider: \_\_\_\_\_ (4 digits max)
- Multiplier: \_\_\_\_\_ (4 digits max)



Description

The Redington Model 57 family of LCD indicators offers a variety of options to fulfill your count/hour meter requirements. This indicator can display hours, counts or both with a single-line shared display. This model is available with an LED indication for service and relay or transistor output. You decide which value should be displayed permanently and which one will be in the background. The background indication will appear for approximately 10 seconds every time you apply power to the meter.

When using a counter and an hour meter in combination, the counter will count the number of input pulses while the hour meter will record the total duration of the input pulses.

The Redi-Alert Service Interval feature notifies operators of service requirements when service intervals are a function of the number of events or time. If a Redi-Alert Service Interval is specified, the display will show the count (or time) remaining until the service interval is reached. The Redi-Alert Service Interval feature can be considered to be a down-counter (or down-timer) since the count (or time) that is displayed shows what remains until service is required. When the Redi-Alert Service Interval gets to zero, the indicator will flash the display. If the Redi-Alert Service Interval is not reset, the indicator will continue to operate, and the display will show negative counts (or time) indicating how far the system has gone past the service interval. If the prewarn feature is included, the display will begin flashing when the prewarn count (or time) is reached. When the Service Interval is in the background, it will come to the foreground when it reaches the service interval or the prewarn. Resetting the indicator resets the Service Interval to its specified setting and returns the Service Interval to the background.

The LED indicator and output will come on once the Redi-Alert is reached and stay on until reset.

The Model 57 family also offers the option of an additional display for those applications that require dual indications.

Features

- Choice of single or dual displays
- Display counts/hours or both
- Factory programmed service alert
- Divide/multiply on inputs (factory set)
- With or without reset
- Output signal: none, relay or transistor
- Service indicator available
- DC input voltages
- IP 65 sealed front panel
- EEPROM for memory (no battery)

Options

- Input scaling
- Count speed
- Reset type
- Indication of time/count
- Type of output
- One or two displays
- LED indication for service
- Maintenance Redi-Alert output

Specifications

<b>Display:</b>	Large 7 digit, 0.28 [7mm], LCD 1 or 2 displays	<b>Protection:</b>	IP 65 front panel/gasket supplied
<b>Quartz Accuracy:</b>	0.01% over entire voltage & temp. range	<b>EMC:</b>	EN 55011, EN 50082-2
<b>Input Voltage:</b>	12-24 VDC/ ±25% 24 VDC/ ±25% - with relay output	<b>Vibration:</b>	1g (10...500 Hz) IEC 68-2-34 30 g(18 msec.) IEC 68-2-27
<b>Special Voltages:</b>	24-48 VDC/ ±25% 12,36,48 VDC/ ±25%-with relay output	<b>Shock:</b>	25 g(6 msec) IEC 68-2-29
<b>Current Consumption:</b>	12-24 VDC/<10 mA, 24-48 VDC/<10 mA (12 V/< 35 mA, 24 V/< 25 mA, 36 V/<25 mA, 48 V/< 20 mA) with relay	<b>Max Count Speed:</b>	30 or 200 Hz (specify)
<b>Relay Contact:</b>	1 dry contact / breaking capacity 12 V/2 A, 24 V/2 A, 36 V/1.5 A, 48 V/1 A	<b>Memory:</b>	EEPROM (no battery)
<b>Transistor Output:</b>	V <sub>OH</sub> 4.5 VDC, minimum through 30 KW V <sub>OL</sub> 0.4 VDC, maximum through 20 KW I <sub>SINK</sub> 1.0 mA, maximum	<b>Mounting:</b>	Metal clamp
<b>Operating Temperature :</b>	-22 °F to +158 °F [-30 °C to +70 °C]	<b>Electrical Connection:</b>	8 pole compact plug with lock
<b>Approvals:</b>	CE Compliant	<b>Case Material:</b>	Black, ABS plastic w/glass lens
		<b>Reset:</b>	Manual & remote (manual button on the rear of housing), non-reset, remote
		<b>Service Alert:</b>	Factory set - one Redi-Alert, 4 digits
		<b>Prewarn Signal:</b>	Factory set, 4 digits
		<b>Input Scaling:</b>	Factory set, 4 digits
		<b>Weight:</b>	3.5 oz [99g]



Models Description

For Details on Models and Descriptions, see the Ordering Information section.

Dimensions

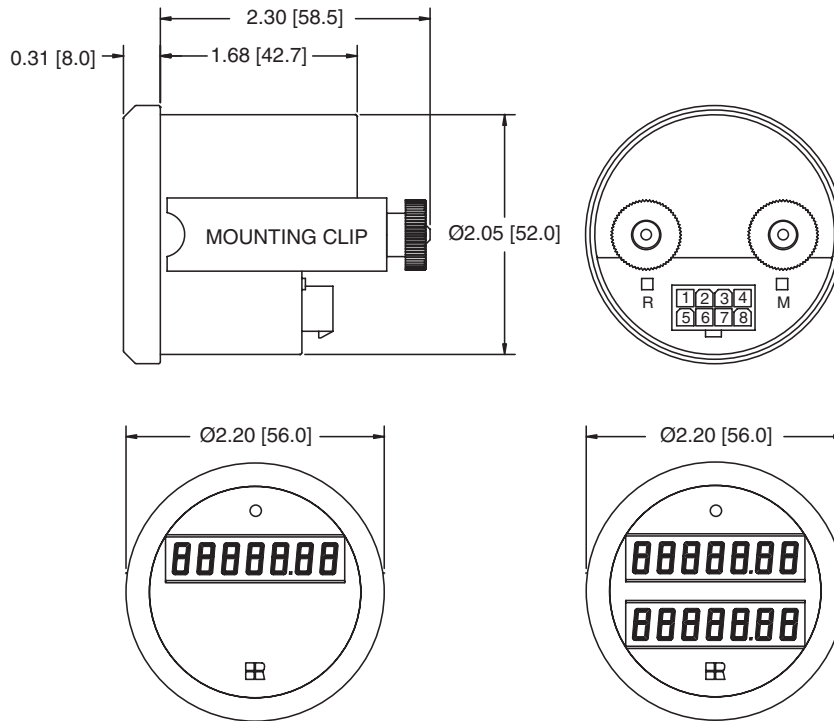

Maximum Panel Thickness: 0.20" [5.1mm]  
 Panel Cutout: 2.06" [52.2mm]

Wiring Diagram

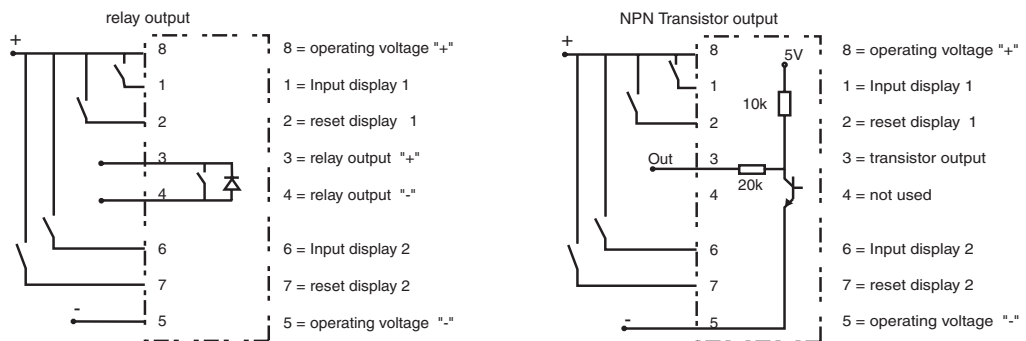

Applications

Panel Builders



Medical Devices



Packaging Machinery

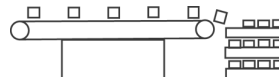

Test Equipment





Ordering Information

Model No.	Voltage	Function	Reset	Notes
5700	12 - 24 VDC	HM*	HM	without output or LED
5701	12 - 24 VDC	C*	C	without output or LED
5702	12 - 24 VDC	HM with HM (bg)*	HM	without output or LED
5703	12 - 24 VDC	C with C (bg)*	C	without output or LED
5704	12 - 24 VDC	HM with C (bg)*	BOTH	without output or LED
5705	12 - 24 VDC	C with HM (bg)*	BOTH	without output or LED
5706	24 VDC	HM with SHM (bg)*	SHM	with relay output and LED
5707	12 - 24 VDC	HM with SHM (bg)*	SHM	with transistor output and LED
5708	24 VDC	C with SC (bg)*	SC	with relay output and LED
5709	12 - 24 VDC	C with SC (bg)*	SC	with transistor output and LED
5710	24 VDC	SHM with HM (bg)*	SHM	with relay output and LED
5711	12 - 24 VDC	SHM with HM (bg)*	SHM	with transistor output and LED
5712	24 VDC	SC with C (bg)*	SC	with relay output and LED
5713	12 - 24 VDC	SC with C (bg)*	SC	with transistor output and LED

\*HM= Hour Meter \*C= Counter \*bg= Background \*SHM= Service Hour Meter \*SC= Service Counter

Model 57 Specification Sheet

Company: \_\_\_\_\_  
Address: \_\_\_\_\_  
Contact: \_\_\_\_\_

Phone: \_\_\_\_\_  
Fax: \_\_\_\_\_  
Email: \_\_\_\_\_  
Date: \_\_\_\_\_

Model No. \_\_\_\_\_ (4 digits) SELECTED FROM ABOVE TABLE

Display 1

Display 2 (Optional)

Yes

No

Indication of time for Hour Meter: (check only 1)

- 1/100<sup>th</sup>
- 1/10<sup>th</sup>

Indication of time for Hour Meter: (check only 1)

- 1/100<sup>th</sup>
- 1/10<sup>th</sup>

Max. counting frequency for Counter: (check only 1)

- 30 Hz
- 200 Hz

Max. counting frequency for Counter: (check only 1)

- 30 Hz
- 200 Hz

Reset types: (check only 1)

- non-reset
- remote reset
- remote & manual (manual reset on rear of housing)

Reset types: (check only 1)

- non-reset
- remote reset
- remote & manual (manual reset on rear of housing)

Service interval (optional)

- "Redi-Alert": \_\_\_\_\_ ( 4 digits max)
- Prewarn: \_\_\_\_\_ (4 digits max.)

Input scaling: (optional - check only 1)

- Divider \_\_\_\_\_ ( 4 digits max)
- Multiplier \_\_\_\_\_ ( 4 digits max)

Input scaling (optional - check only 1)

- Divider \_\_\_\_\_ ( 4 digits max)
- Multiplier \_\_\_\_\_ ( 4 digits max)

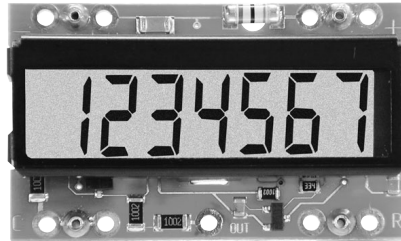

### Description

The Redington Model 59 line of LCD modules can easily be integrated into your equipment or machinery. These functions are also available in cased versions, ask for more information, or see Model 55, 56 & 57.

#### Single Indicator:

Can be used to display hours or count.

#### Twin Indicator:

These models can supply two indications in one display. You can decide which function should be indicated permanently and which one in the background. The background function displays for approximately 10 seconds every time you power-up the display. When using a counter and an hour meter in combination, the counter will count the number of input pulses while the hour meter will record the total duration of the input pulses. Presettable "prewarn" signals can also be programmed into the modules. If you specify a prewarn the display will flash when it reaches its specified value. A wide range of reset functions are also available to provide you with the exact configuration for your application. Model 57 is available with an output function to "alert" when service or preventive maintenance should occur.

#### Redi-Alert:

The Redington Model 59 LCD Maintenance Meter modules can easily be integrated into your equipment or machinery. This module can display hours, counts or both with a single-line, shared display. You can decide which function should be indicated permanently and which one is in the background. The background function, value, appears for approximately 10 seconds every time you power-up the display. When using a hour meter and counter in combination, the counter will count the number of input pulses while the hour meter will record the total duration of the input pulses. A wide range of reset functions are available to provide you with the exact configuration for your application.

The Redi-Alert Service Interval feature notifies operators of service requirements when service intervals are a function of the number of events or time. If a Redi-Alert Service Interval is specified, the display will show the count (or time) remaining until the service interval is reached. The Redi-Alert Service Interval feature can be considered to be a down-counter (or down-timer) since the count (or time) that is displayed shows what remains until service is required. When the Redi-Alert Service Interval gets to zero, the indicator will flash the display. If the Redi-Alert Service Interval is not reset, the indicator will continue to operate, and the display will show negative counts (or time) indicating how far the system has gone past the service interval. If the prewarn feature is included, the display will begin flashing when the prewarn count (or time) is reached. When the Service Interval is in the background, it will come to the foreground when it reaches the service interval or the prewarn. Resetting the indicator resets the Service Interval to its specified setting and returns the Service Interval to the background. The LED indicator and output will come on once the Redi-Alert is reached and stay on until reset.

### Features

- Display time/count or both
- "Redi-Alert" function for service
- Choice of non-reset or remote reset
- EEPROM for memory (no battery)
- Divider/multiplier
- 30 or 200 Hz, max input frequency
- 1/10<sup>th</sup> or 1/100<sup>th</sup> hour indication
- 12 to 24 VDC power range

### Options

- Input scaling
- Input frequency
- Remote reset
- Service "Redi-Alert"
- Display functions

### Specifications

<b>Display:</b>	7 digit, 0.28 [7mm], LCD	<b>Electrical Connection:</b>	Pins for soldering
<b>Quartz Accuracy:</b>	0.01%	<b>Reset:</b>	Non-reset, remote
<b>Input Voltage:</b>	12-24 VDC/ ±25%	<b>Protection:</b>	
<b>Current Consumption:</b>	2-4 mA	<b>EMC:</b>	EN 55011, EN 50082-2
<b>Transistor Output:</b>	$V_{OH}$ 4.5 VDC, minimum through 30 KW	<b>Vibration:</b>	1 g (10 to 500 Hz) IEC 68-2-34
	$V_{OL}$ 0.4 VDC, maximum through 20 KW	<b>Shock:</b>	30 g (18 msec.) IEC 68-2-27
	$I_{SINK}$ 1.0 mA, maximum		25 g (6 msec.) IEC 68-2-29
<b>Operating Temperature:</b>	-22°F/+158°F [-30°C to +70°C]	<b>Weight:</b>	0.5 oz [14g]
<b>Max Count Speed:</b>	30 or 200 Hz	<b>Service Alert:</b>	1 "Redi-Alert", 4 digits, factory set
<b>Memory:</b>	EEPROM (no battery)	<b>Input Scaling:</b>	Factory set, 4 digits
<b>Approvals:</b>	UL/cUL Recognized	<b>Prewarn Signal:</b>	Factory set, 4 digits
<b>Mounting:</b>	Electrical connection pins for soldering		

### Models Description

For Details on Models and Descriptions, see the Ordering Information section.



Dimensions

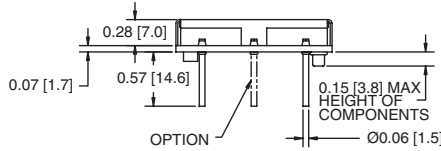
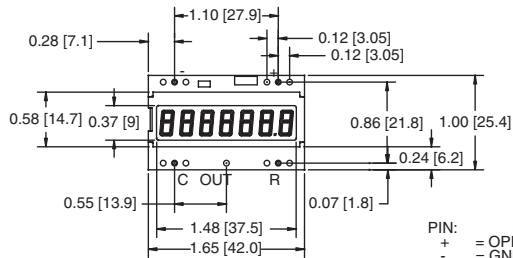

PIN:
+ = OPERATING VOLTAGE
- = GND
C = COUNT
OUT = SERVICE COUNTER OUTPUT (OPTION)
ALTERNATIVE POSITIONS OF THE CONNECTION PINS ARE OPTIONALLY POSSIBLE.

Wiring Diagram
NPN Transistor Output

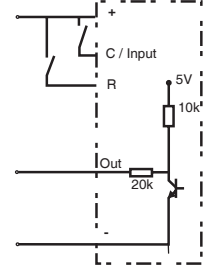

Applications

Test Equipment



Panel Builders

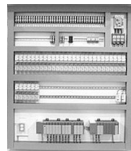

Medical Devices

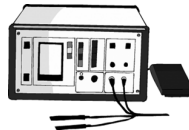

Office Equipment



Flow Meters

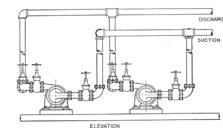

Ordering Information

Table with 4 columns: Model#, Function, Output Signal, Notes. Lists various meter models and their features.

\*HM=HOUR METER \*C= COUNTER \*bg=BACKGROUND \*SC= SERVICE COUNTER \*SHM= SERVICE HOUR METER

Model 59
Specification Sheet

Company:
Address:
Contact:

Phone:
Fax:
Email:
Date:

Model No. (4 digits) SELECTED FROM ABOVE TABLE.

Input voltage: (check only 1)

12-24 VDC Special voltages available, consult factory.

Indication of time for Hour Meter: (check only 1)

1/100th 1/10th

Max. counting frequency for Counter: (check only 1)

30 Hz (DC) 200 Hz DC

Reset type: (check only 1)

non-reset remote reset

Service interval: (optional)

"Redi-Alert": (4 digits max) Prewarn: (4 digits max)

Input scaling: (optional - check only 1)

Divider: (4 digits max) Multiplier: (4 digits max)



Description

A 6 figure, battery powered, push-button or key reset, electronic hour meter, available in base mount or panel mount configuration. No external power supply is required. Large 0.50" [12mm] LCD figures for fast, easy reading. Operates at 6-240 VAC or VDC. Long lasting internal lithium battery. Attractive styling and silent operation make these models equally well-suited for lab or office equipment applications.

Features

- No external power supply needed
- Long life lithium battery
- Large easy reading display
- Operates at 6 to 240 VAC or VDC

Options

- Non-reset
- Remote reset
- Minutes meter
- Seconds meter

Specifications

**Figures:** 6 LCD figures, 0.50" [12mm] high  
**Reset:** Push-button, or lock and key  
**Input:** 6-240VAC (50/60Hz) or 6-240VDC  
 Vih 6VAC/VDC minimum  
 Vil 2VAC/VDC maximum

**Terminations:** (2) #22 AWG 221°F [105° C] wire leads, 8" [203mm] long  
**Temp. Range:** -14°F to +122°F [-26°C to +50°C]  
**Power Source:** Internal lithium battery  
**Weight:** 18 oz. [510g]

**Mounting:** Base or panel

Note: When interfacing the Model 94 with a Solid State Relay or AC Sensor, the leakage current needs to be considered. Contact the factory or see the application note at [www.redingtoncounters.com](http://www.redingtoncounters.com) for further information.

Models Description

- 9425-001 6 figure, base mount, push-button reset
- 9425-003 6 figure, panel mount, push-button reset
- 9425-005 6 figure, panel mount, lock and key reset

\* Items are normally in factory stock.

Dimensions

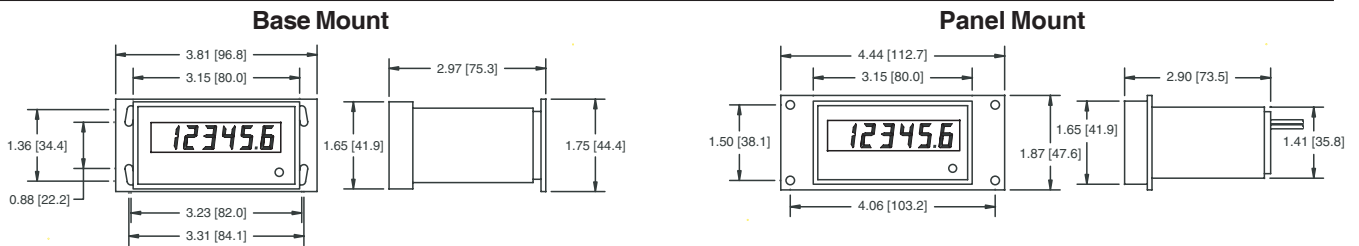

Mounting holes: 0.14" x 0.24" [3.6mm x 6.1mm] slots

Panel cutout: 3.0" x 1.75" [76.2mm x 44.5mm]  
Mounting holes: 0.17" [4.3mm] Dia.

Panel Mount/Lock & Key Reset

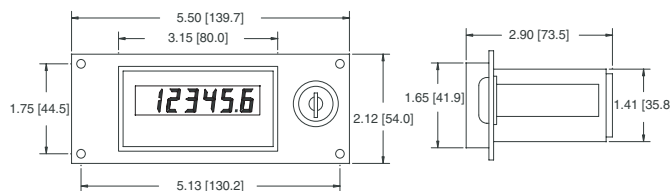

Panel cutout: 4.75" x 1.50" [76.2mm x 44.5mm]  
Mounting holes: 0.17" [4.3mm] Dia.

Applications

Office equipment



Production

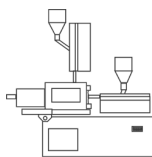

Test labs



Control panels

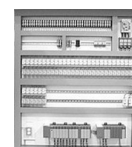



**Description**

The Redington Model 720 Electronic Hour Meter offers a large 7 digit LCD display, (999999.9) 0.32" (8mm) high, with an input operating voltage of 85-500VAC. The front of the unit is totally sealed, and the Hour Meter is housed in a rugged steel enclosure that is interchangeable with the Redington Model 720 Electro Mechanical Hour Meters. The wide operating voltage makes this product ideal for almost any application.

**Features**

- Operating voltage 85-500VAC
- Rugged steel housing
- Lithium battery
- Quartz accuracy (better than 0.01%)
- Popular 3-hole mounting

**Options**

- Gasket (721-0004)
- Special termination available
- DC

**Specifications**

**Display:** Large 7 digit LCD (999999.9), 0.32" [8mm] high  
**Reset:** Non-reset  
**Voltage:** 85-500VAC 50/60Hz  
**Hour Meter Memory:** Self-powered (internal lithium battery)  
**Termination:** Wire leads 6" [152mm]  
**Mounting:** Panel (3-Hole)  
**Temp. Range:**  
**Operating:** -4°F to + 140°F (-20°C to +60°C)  
**Storage:** -40°F to +165°F (-40°C to +75°C)

**Humidity:** 0 to 95% RH, non-condensing, front totally sealed  
**Vibration:** 10 to 80 Hz, 0.06 double amplitude  
**Shock:** 50G  
**Dielectric:** 1000VAC 50/60Hz for 1 minute  
**Accuracy:** Quartz accuracy (better than 0.01%)  
**Weight:** 5.0 oz (142g)

**Models Description**

**720-5300** 85-500VAC, non-reset, 3-hole round, 6" (152mm) wire leads  
 \* Item is normally in factory stock.

**Dimensions**

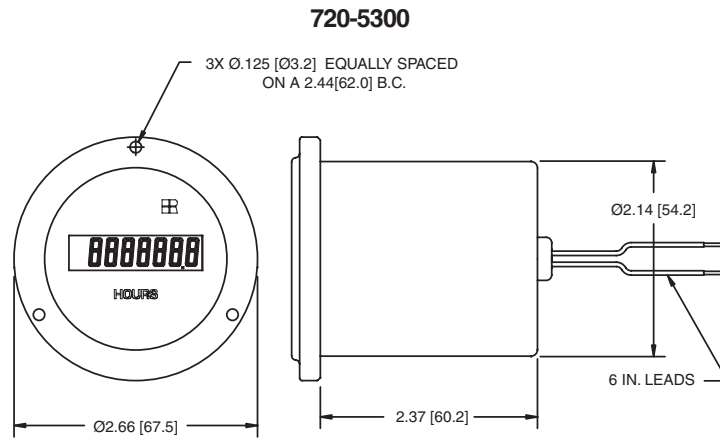

Panel cutout: 2.16" [54.9] Dia.  
 Mounting holes: 0.125" [3.2] Dia. on 2.44" [62.0] B.C.

**Applications**

Control panels

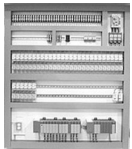

Outdoor Lighting



Industrial Equipment

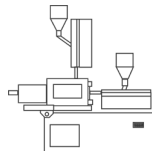

Compressors

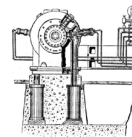

Test equipment







**Description**

The Model 77 is a compact, non-reset, 6 figure, 99999.9, electromechanical hour meter. Available with several mounting styles, panel, behind the panel and "snap-in" mount. Products are UL Recognized, CSA Certified and CE Compliant.

**Features**

- Panel or snap-in mount
- Compact size
- Non-reset

**Options**

- Voltage
- Frequency
- Mounting

**Specifications**

**Figures:** 6 figures, 0.11" [3mm] high  
99,999.9 hours

**Reset:** Non-reset

**Voltages:** 115VAC, (+/- 10%) 60Hz.

**Power:** 3 watts (nominal)

**Mounting:** Panel (front, behind, or snap-in)

**Termination:** Screw type, round terminals

**Temp. Range:** -60°F to +154°F [-51°C to +68°C]

**Approvals:** UL Recognized, CSA Certified, CE Compliant

**Weight:** 2.5 oz. [71g]

**Models Description**

P2-7717/60 115VAC/60Hz, non-reset, panel mount

R2-7717/60 115VAC/60Hz, non-reset, behind the panel mount

**Models Description**

SR2-7717/60 115VAC/60Hz, non-reset, snap-in mount

**Dimensions**

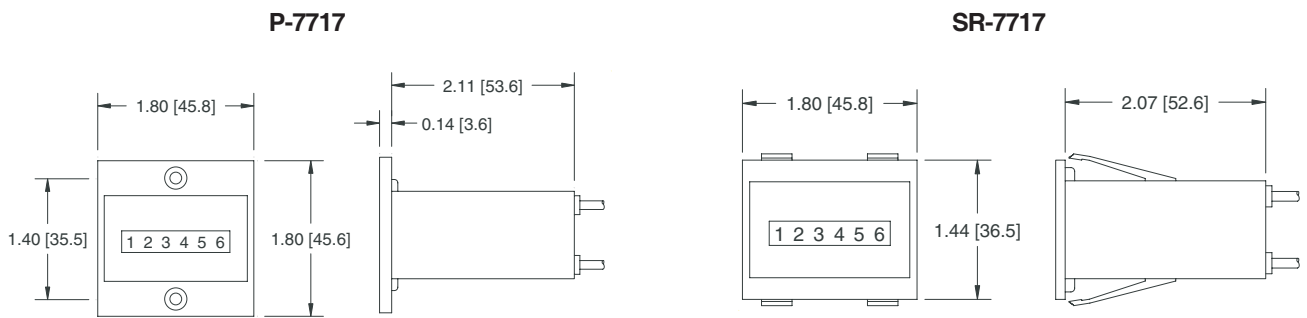

Panel cutout: 1.72" x 1.05" [43.7 x 26.7]  
Mounting holes: For #5 flat head screw

Panel cutout: 1.68" x 1.31" [42.7 x 33.3]

**Applications**

Test equipment



Control panels



Office machines



Industrial equipment

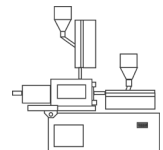



Description

The model 710 AC hour meters and minute meters are widely used in panel applications where number size and visibility are critical. Its tough, Lexan bezel and distinctive styling enhance appearance and durability. Available in 5 figure reset or 6 figure non-reset versions.

Features

- Large figures
- Tough, Lexan case
- Reset or non-reset

Options

- Private label faceplates
- Bracket mount
- Mounting bracket (721-0003)
- Splash proof kit (721-0017)
- Heavy duty splash proof kit (721-0018)
- Gasket (721-0004)

Specifications

**Figures:** 5 figures, 9999.9 (reset) or 6 figure, 99999.9 (non-reset), 0.19" [5mm] high  
**Reset:** Reset (on front or side) or non-reset  
**Voltages:** 24, 115 or 230VAC, (+/-10%), 50 or 60 Hz.  
**Power:** 3 watts (nominal)  
**Mounting:** Panel (3-hole)

**Terminations:** 8" [203.2mm] wire leads or terminal block  
**Temp. Range:** -20°F to +160°F [-29°C to +71°C]  
**Approvals:** UL Recognized, CSA Certified, CE Compliant  
**Weight:** 6 oz. [170g]

Models	Description	Models	Description
<b>710-0001</b>	115VAC/60Hz, non-reset, 99,999.9 hrs, 8" [203mm] wire leads	<b>710-0014</b>	230VAC/60Hz, non-reset, 99,999.9 hrs, terminal block
<b>710-0002</b>	115VAC/60Hz, non-reset, 99,999.9 hrs, terminal block	710-0018	115VAC/60Hz, non-reset, 99,999.9 min, 8" [203mm] wire leads
<b>710-0003</b>	230VAC/60Hz, non-reset, 99,999.9 hrs, 8" [203mm] wire leads	710-0024	24VAC/60Hz, non-reset, 99,999.9 hrs, terminal block
<b>710-0006</b>	24VAC/60Hz, non-reset, 99,999.9 hrs, 8" [203mm] wire leads	<b>710-0026</b>	115VAC/50Hz, non-reset, 99,999.9 hrs, terminal block
710-0008	115VAC/60Hz, non-reset, 99,999 hrs, 8" [203mm] wire leads	<b>710-0032</b>	115VAC/60Hz, front reset, 9,999.9 hrs, terminal block
<b>710-0009</b>	115VAC/50Hz, non-reset, 99,999.9 hrs, 8" [203mm] wire leads	710-0051	115VAC/60Hz, non-reset, 99,999 hrs, terminal block
<b>710-0013</b>	115VAC/60Hz, front reset, 9,999.9 hrs, 8" [203mm] wire leads		

\* Items in bold are normally in factory stock.

Dimensions

8" [203mm] Wire Leads

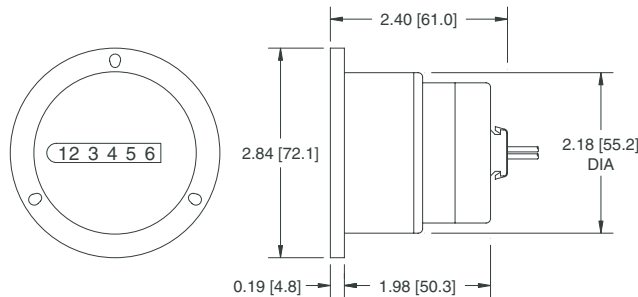

Mounting holes: For #4 screws on 2.44" [62.0] B.C.  
 and #6 screws on 2.53" [64.3] B.C.  
 Panel cutout: 2.21" [56.1] Dia.

Applications

Office equipment



Control panels

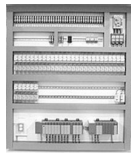

Industrial equipment

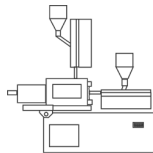

Test equipment



Compressors

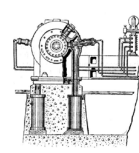



Description

The Redington Model 711/731 provides a family of compact 7 figure, AC or DC Hour Meters. Models are available in the standard industry housings, 2-Hole rectangular, flush-round and flush-rectangular. DC Models are quartz controlled for high reliability and accuracy. A choice of two rectangular panel cutouts are offered 1.45" X 0.95" [36.8mm X 24.1mm] or 1.45" X 0.87" [36.8mm X 2.1mm]. The Round meter has a panel cutout of 1.99" [50.5mm].

Features

- 7 figure, 99999.99
- Various voltage inputs
- Quartz accuracy (DC)
- Large figures, 0.14" [3.6mm]
- CE Compliant
- UL Recognized/CSA Certified for AC
- UL/cUL Recognized for DC

Options

- Special voltages
- Terminations
- Panel cutout

Specifications

**Figures:** 7 figures, 0.14" [3.6mm] 99999.99  
**Reset:** Non-reset  
**Voltages:** 24, 115 or 230VAC (± 10%), 50 or 60 Hz 10-28VDC  
**Power:** 2 watts AC, 0.4 watts DC  
**Mounting:** Clip or mounting holes  
**Termination:** 1/4" [6.3mm] spade terminals with screws (AC)  
 1/4" [6.3mm] spade terminals (DC)  
**Accuracy:** 0.01% (DC) quartz  
**Case Material:** Black polymer  
**Agency Approvals:** CE Compliant  
 UL Recognized/CSA Certified for AC  
 UL/cUL Recognized for DC  
**Weight:** 1.2oz. [35g]

**Environmental:**  
**Front Panel:** IP65  
**Operating Temperature:** -40°F to +180°F [-40°C to +82°C]  
**Storage Temperature:** -40°F to +185°F [-40°C to +85°C]  
**Humidity:** 95% RH- SAE J 1378  
**Vibration:** 20g's @ 10-80 Hz- SAE J 1378  
**Shock:** 55g's @ 9-13 msec.- SAE J 1378  
**Transient Immunity:** EMI: ± 400V@ 500Hz  
**Alternator Load Dump:** 150V inductive switching, reverse polarity and over voltage protection

Models

Models	Voltage AC	Mount	Panel Cut-out		
			1.45 X .87	1.45 X .95	1.99
711-0013	115VAC/60Hz	Round			X
711-0014	230VAC/60Hz	Round			X
711-0015	24VAC/60Hz	Round			X
<b>711-0113</b>	115VAC/60Hz	Flush Rect	X		
<b>711-0114</b>	24VAC/60Hz	Flush Rect.	X		
711-0120	115VAC/60Hz	Flush Rect		X	
711-0123	230VAC/60Hz	Flush Rect.		X	
711-0124	24VAC/60Hz	Flush Rect.		X	
<b>711-0130</b>	115VAC/60Hz	2-Hole	X		
711-0131	230VAC/60Hz	2-Hole	X		
711-0132	24VAC/60Hz	2-Hole	X		
711-0133	115VAC/50Hz	2-Hole	X		
711-0134	230VAC/50Hz	2-Hole		X	
711-0138	230VAC/60Hz	Flush Rect.	X		
711-0215	115VAC/60Hz	2-Hole		X	
711-0216	230VAC/60Hz	2-Hole		X	
711-0217	24VAC/60Hz	2-Hole		X	

Models	Voltage DC	Mount	Panel Cut-out		
			1.45 X .87	1.45 X .95	1.99
731-0006	10-28VDC	Round			X
<b>731-0040</b>	10-28VDC	2-Hole	X		
731-0041	10-28VDC	Flush Rect	X		
731-0042	10-28VDC	Flush Rect		X	
731-0051	10-28VDC	2-Hole		X	

\* Items in bold are normally in factory stock.



Dimensions

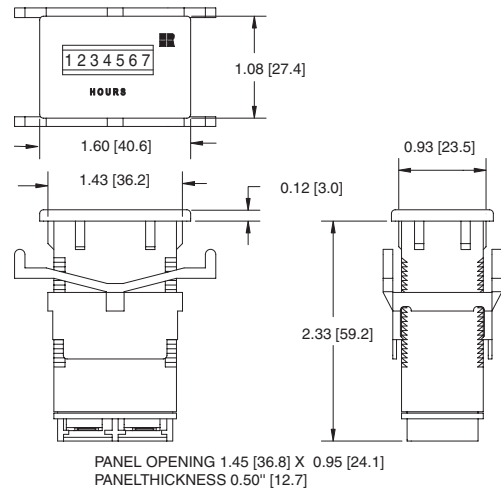
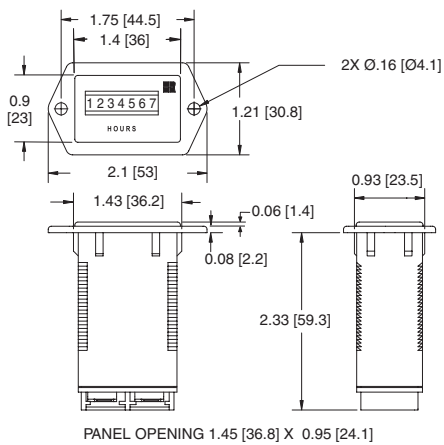
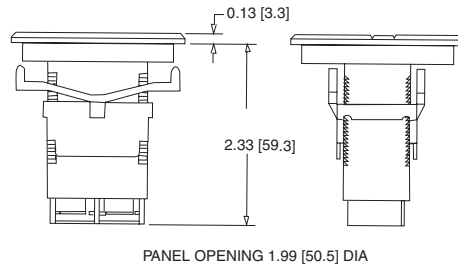
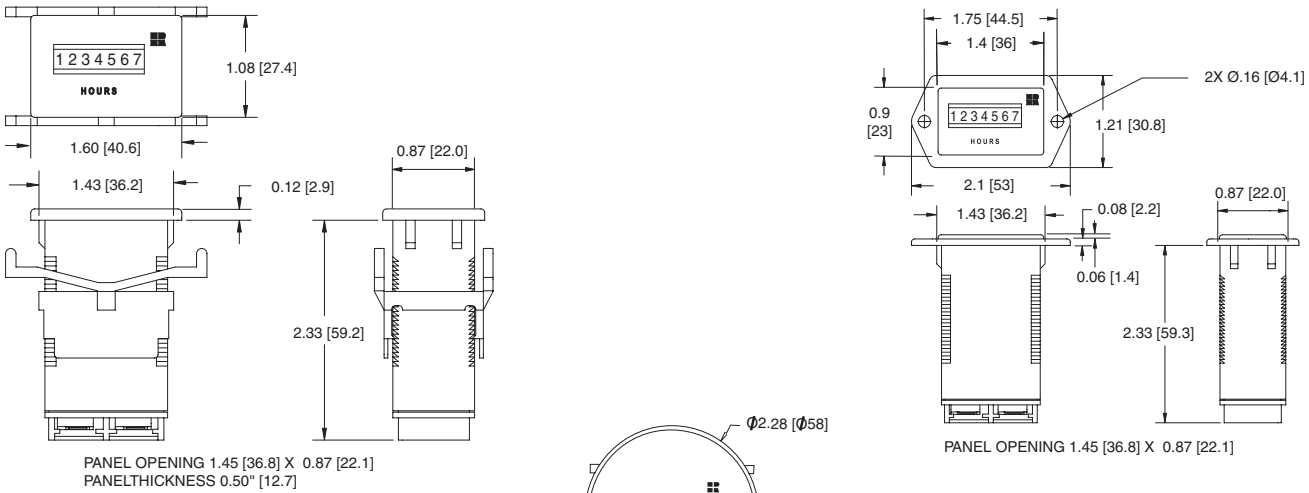

Applications

Medical equipment



Test equipment



Office equipment





Description

These 7 figure, AC or DC hour meters with running indicators, offer crisp, distinctive styling for many panel applications. Available in square and round bezel, flush mount, or three-hole round panel mount. Each is light-weight, low power, and carry UL, CSA and CE approvals.

Features

- 7 figure, 99999.99
- Various voltage inputs
- Distinctive styling

Options

- Terminations
- Din rail
- Voltages

Specifications

**Figures:** 7 figures, 0.14" high [3.6mm], 99,999.99 hours  
**Reset:** Non-reset  
**Voltages:** 24, 115, or 230VAC (+/-10%), 50 or 60Hz., 10-80 VDC  
**Power:** 3 watts (AC), 1.2 watt maximum (DC)  
**Terminations:** 1/4" [6.3mm] spade terminals, with removable screws, or 8" [203mm] wire leads

**Mounting:** Panel (mounting hardware included)  
**Temp. Range:** -22°F to +158°F [-30°C to +70°C]  
**Approvals:** UL Recognized and CSA Certified (AC only), CE Approved  
**Weight:** 2 oz. [57g]

Models	Description	Models	Description
<b>711-0150</b>	115VAC/60Hz, 2.28" Dia., Flush mount, screw termination	711-0182	24VAC/60Hz, 1.89" Sq., Flush mount, screw termination
711-0152	230VAC/60Hz, 2.28" Dia., Flush mount, screw termination	<b>711-0190</b>	115VAC/60Hz, 2.05" Sq., Flush mount, screw termination
<b>711-0160</b>	115VAC/60Hz, 2.93" Dia., 3-hole round, screw termination	711-0191	230VAC/60Hz, 2.05" Sq., Flush mount, screw termination
711-0161	115VAC/50Hz, 2.93" Dia., 3-hole round, screw termination	711-0192	24VAC/60Hz, 2.05" Sq., Flush mount, screw termination
711-0162	230VAC/60Hz, 2.93" Dia., 3-hole round, screw termination	711-0193	115VAC/50Hz, 2.05" Sq., Flush mount, screw termination
711-0163	230VAC/50Hz, 2.93" Dia., 3-hole round, screw termination	711-0194	230VAC/50Hz, 2.05" Sq., Flush mount, screw termination
711-0164	24VAC/60Hz, 2.93" Dia., 3-hole round, screw termination	711-0195	24VAC/50Hz, 2.05" Sq., Flush mount, screw termination
711-0170	230VAC/60Hz, 2.93" Dia., 3-hole round, 8" wire leads		
711-0171	115VAC/60Hz, 2.93" Dia., 3-hole round, 8" wire leads	<b>731-0046</b>	10-80VDC, 2.93" Dia., 3-hole round, screw termination
<b>711-0180</b>	115VAC/60Hz, 1.89" Sq., Flush mount, screw termination		

\* Items in bold are normally in factory stock.

Dimensions

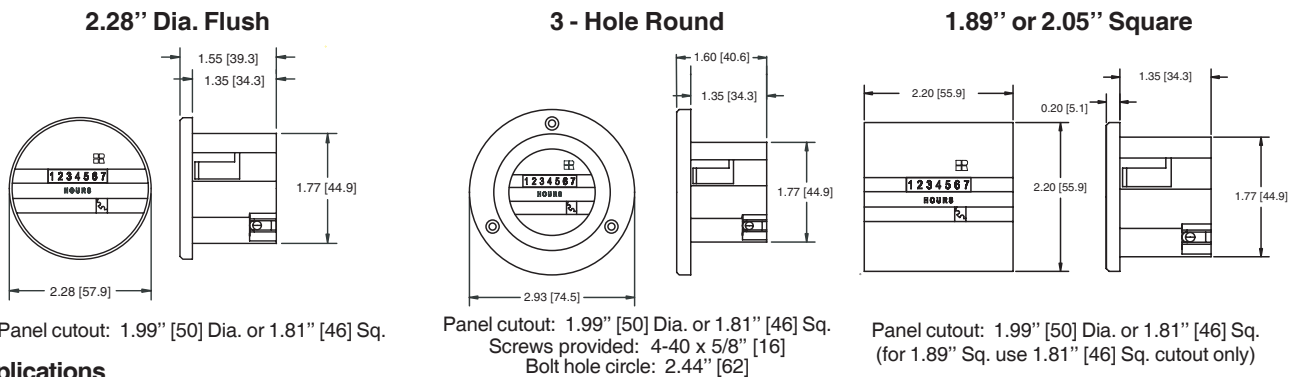

Applications

Medical equipment



Test equipment



Office equipment





Description

A rectangular style AC hour meter designed to complement existing meters in control panels. Available in 6 figure reset or 7 figure non-reset. The non-reset model incorporates a retaining clip to lock into panel, while the reset version has a metal bracket and screw.

Features

- Large figures
- 6 or 7 digits
- UL Recognized, CSA Certified, CE Compliant

Options

- Reset or non-reset

Specifications

<b>Figures:</b>	6 figure (reset) or 7 figure (non-reset), 0.19" [5mm] high 9,999.99 hours. (reset version) 99,999.99 hours. (non-reset models)	<b>Mounting:</b>	Panel (mounting hardware included)
<b>Reset:</b>	Push-button, or non-reset	<b>Termination:</b>	19" [483mm] wire leads
<b>Voltages:</b>	115VAC (+/- 10%), 50 or 60 Hz.	<b>Temp. Range:</b>	-4°F to +158°F [-20°C to +70°C]
<b>Power:</b>	2 watts (nominal)	<b>Approvals:</b>	UL Recognized, CSA Certified, CE Compliant
		<b>Weight:</b>	2 oz. [57g]
		<b>Options:</b>	Voltages

Models Description

<b>711-0019</b>	115VAC/60Hz, reset, 6 figure, 9,999.99 hrs., 19" [483mm] wire leads
<b>711-0020</b>	115VAC/60Hz, non-reset, 7 figure, 99,999.99 hrs., 19" [483mm] wire leads
<b>711-0041</b>	115VAC/50Hz, non-reset, 7 figure, 99,999.99 hrs., 19" [483mm] wire leads

Dimensions

Non-Reset

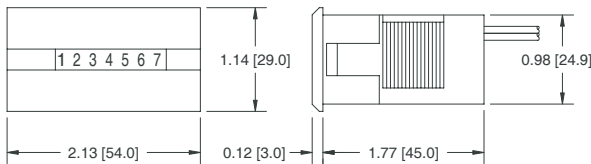

Panel cutout: 1.98" x 0.99" [50.3 x 25.1]

Reset

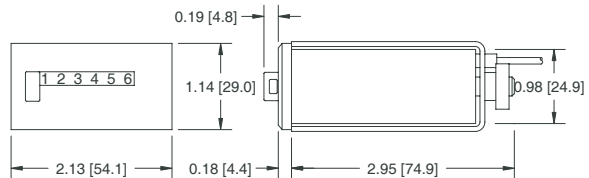

Panel cutout: 1.98" x 0.99" [50.3 x 25.1]

Applications

Medical equipment



Test equipment



Office equipment





**Description**

A 5 figure (reset) or 6 figure (non-reset), AC hour meter encased in a rugged steel housing and designed to mil-spec environmental requirements. The non-reset models are completely sealed, and meet NEMA 4 standards. Reset models are available, as are both wire lead and terminal block versions.

**Features**

- Rugged steel housing
- Mil-spec

**Options**

- Chrome bezel
- Readouts to 9999.99 hrs.
- Minute meter
- Voltages
- Gasket (721-0004)

**Specifications**

**Figures:** 5 figure (reset) or 6 figure (non-reset), 0.19" [5mm] high, 9,999.9 (reset) or 99,999.9 (non-reset)  
**Reset:** Reset or non-reset  
**Voltages:** 24, 115, and 230VAC (+/- 10%), 50 or 60Hz.  
**Power:** 2.5 watts (nominal)

**Mounting:** Panel (3-hole or metal clamp)  
**Termination:** Terminal block or 6" [152mm] wire leads  
**Temp. Range:** -65°F to +155°F [-54°C to +68°C]  
**Approvals:** UL Recognized, CSA Certified, CE Compliant  
**Weight:** 10 oz. [284g]

**Models Description**

**720-0001** 24VAC/60Hz, non-reset, 3-hole round, 6" [152.4mm] wire leads  
**720-0003** 115VAC/60Hz, M3971/2-1 and M3971/2-5  
**720-0004** 115VAC/60Hz, non-reset, 3-hole round, terminal block  
**720-0007** 115VAC/60Hz, non-reset, 3-hole round, 6" [152.4mm] wire leads  
**720-0008** 115VAC/60Hz, non-reset, metal clamp, terminal block

**Models Description**

**720-0011** 115VAC/60Hz, non-reset, metal clamp, 6" [152.4mm] wire leads  
**720-0012** 115VAC/60Hz, front reset, 3-hole round, 6" [152.4mm] wire leads  
**720-0030** 115VAC/50Hz, non-reset, 3-hole round, 6" [152.4mm] wire leads  
**720-0031** 230VAC/60Hz, non-reset, 3-hole round, terminal block  
**720-0036** 230VAC/60Hz, non-reset, 3-hole round, 6" [152.4mm] wire leads

\* Items in bold are normally in factory stock.

**Dimensions**

**Non-Reset / Terminal Block**

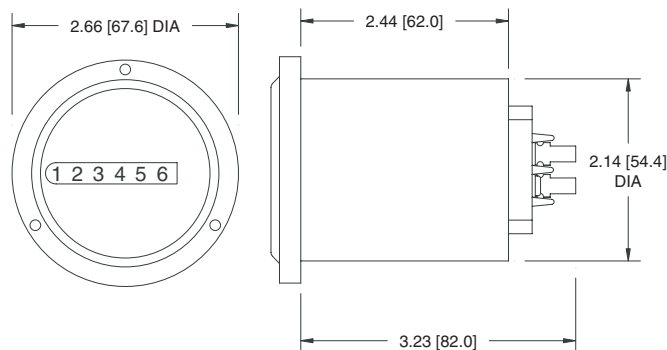

Panel cutout: 2.16" [54.9] Dia.  
 Mounting holes: 0.125" [3.2] Dia. on 2.44" [62.0] B.C.

**Applications**

Control panels



Industrial equipment

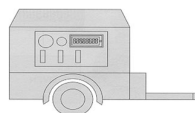

Test equipment





**Description**

The Redington Model 722 provides an AC Hour Meter with an operating range of 90-240VAC (± 10%) 50/60 Hz. You no longer require two separate meters, one for 115VAC and one for 230VAC. Models are available in the standard industry housings, 2-Hole Rectangular, Flush-Rectangular, Flush-Round and 3-Hole Round. Models 722-0001 and 722-0002 fit a panel opening of 1.45" X 0.95" [36.8mm X 24.1mm]. The Flush-Round Model 722-0003 and 3-Hole Model 722-0004 have a panel opening of 2.0" [50.6mm]. The Model 722 quartz time base insures accurate long-term time keeping. The Totally Sealed case protects against the environment and provides years of reliable service. Model 722-0004, 3-Hole mount, is NEMA 4X,12 rated when mounted with optional gasket.

**Features**

- Operating voltage 90-240VAC 50/60Hz
- Totally sealed
- UL/CSA Recognized, CE Compliant
- 6 Figure, 99999.9
- Quartz accuracy

**Options**

- Wire leads
- 3-hole mount gasket kit (part# 5003-007S) (for NEMA 4X, 12 rating)

**Specifications**

**Figures:** 6 - digits, 0.125" [3.2mm] 99999.9  
 Hours - white on black  
 Tenths - red on white

**Reset:** Non-reset

**Voltage:** 90-240VAC (± 10%)

**Frequency:** 50/60Hz

**Power:** Less than 0.6 watts

**Mounting:** Clip or mounting holes

**Termination:** ¼" [6.3mm] spade terminals

**Weight:** 2 oz [57 g]

**Accuracy:** ± 0.02 over entire range

**Case Material:** Black polymer

**Agency Approvals:** UL/CSA Recognized, CE Compliant

**Environmental:** Totally sealed (all models)

**Front Panel:** Model: 722-0004, NEMA 4X, 12 rated with optional gasket (part# 5003-007S)

**Temperature:** -40°F to +185°F [-40°C to + 85°C]

**Vibration:** 10-75 Hz @ 1 to 8g's

**Models**

**Description**

<b>722-0001</b>	2-Hole Rectangular, 90-240VAC 50/60Hz, ¼" [6.3mm] spade terminals, hours & 1/10's
<b>722-0002</b>	Flush-Rectangular, 90-240VAC 50/60Hz, ¼" [6.3mm] spade terminals, hours & 1/10's
<b>722-0003</b>	Flush-Round, 90-240VAC 50/60Hz, ¼" [6.3mm] spade terminals, hours & 1/10's
<b>722-0004</b>	3-Hole Round, 90-240VAC 50/60Hz, ¼" [6.3mm] spade terminals, hours & 1/10's
<b>5003-007S</b>	NEMA 4X, 12 Gasket kit and hardware for 3-Hole Round model (722-0004)

\* All items are normally in factory stock





Dimensions

2-Hole

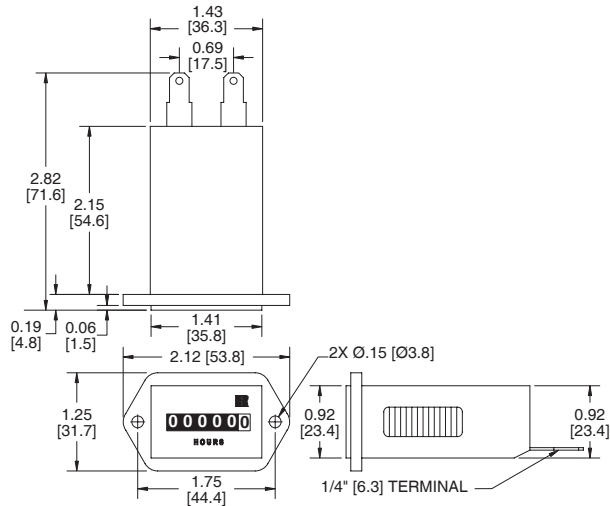

Panel Opening: 1.45" X 0.95" [36.8 X 24.1]

Flush-Rectangular

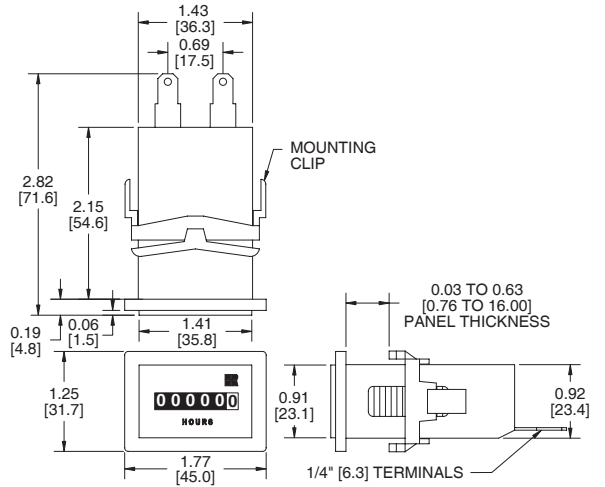

Panel Opening: 1.45" X 0.95" [36.8 X 24.1]  
Panel Thickness: 0.03 to 0.63 [0.76 to 16.00]

Flush-Round

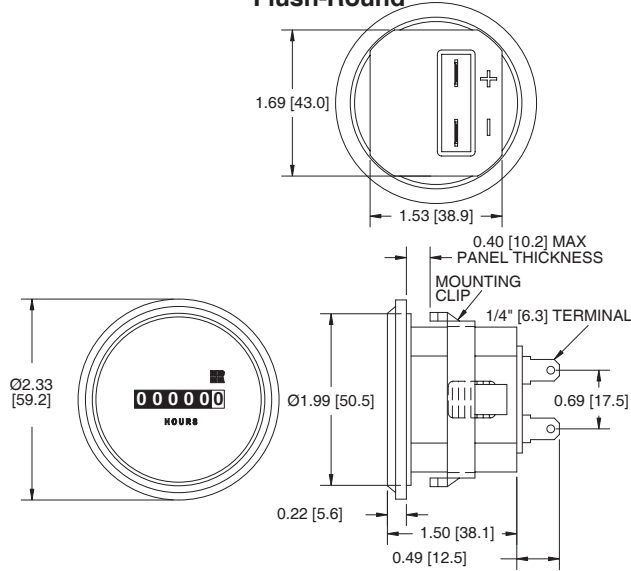

Panel Opening: 2.0" [50.6]  
Panel Thickness: 0.40 [10.2] Max.

3-Hole Round

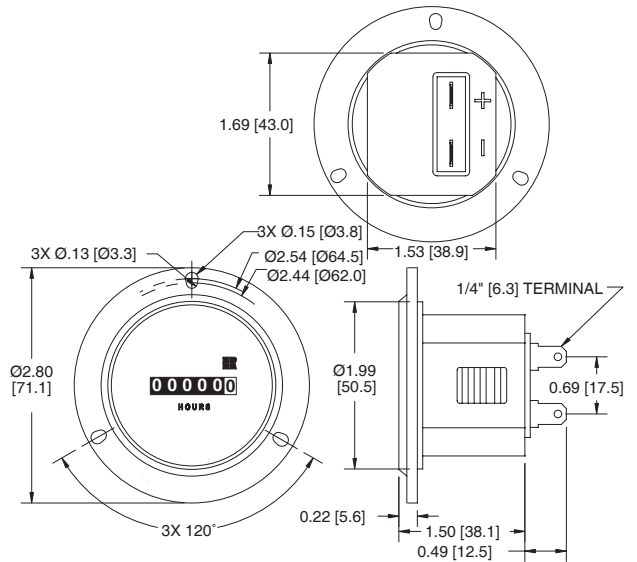

Panel Opening: 2.0" [50.6]

Applications

Medical Equipment



Test Equipment



Office Equipment





Description

The Redington Model 732 provides a DC Hour Meter with an operating range of 10-80VDC. Models are available in the standard industry housings, 3-Hole Round, Flush-Rectangular, Flush-Round and 2-Hole Rectangular. Models 732-0002 and 732-0004 fit a panel opening of 1.45" X 0.95" [36.8mm X 24.1mm]. The Flush-Round Model 732-0003 and 3-Hole Model 732-0001 fit a panel opening of 2.0" [50.6mm]. Its quartz time base insures accurate long-term time keeping. The Totally Sealed case protects against the environment and provides years of reliable service. The 3-Hole Round housing is NEMA 4X,12 rated when mounted with optional gasket.

Features

- Operating voltage 10-80VDC
- Totally sealed
- UL/CSA Recognized, CE Compliant
- 6 Figure, 99999.9
- Quartz accuracy

Options

- Wire leads
- 3-hole mount gasket kit (part# 5003-007S) (for NEMA 4X, 12 rating)

Specifications

<b>Figures:</b>	6 - digits, 0.125" [3.2mm] 99999.9 Hours - white on black Tenths - red on white	<b>Accuracy:</b>	± 0.02 over entire range
<b>Reset:</b>	Non-reset	<b>Case Material:</b>	Black polymer
<b>Voltage:</b>	10-80VDC	<b>Agency Approvals:</b>	UL/CSA Recognized, CE Compliant
<b>Power:</b>	0.3 watts @ 12VDC	<b>Environmental:</b>	Totally sealed (all models)
<b>Mounting:</b>	Clip or mounting holes	<b>Front Panel:</b>	Model: 732-0001, NEMA 4X, 12 rated with optional gasket (part# 5003-007S)
<b>Termination:</b>	¼" [6.3mm] spade terminals	<b>Temperature:</b>	-40°F to +185°F [-40°C to + 85°C]
<b>Weight:</b>	2.0 oz [57 g]	<b>Vibration:</b>	10-75 Hz @ 1 to 8g's

Models

Description

<b>732-0001</b>	3-Hole Round, 10-80VDC, ¼" [6.3mm] spade terminals, hours & 1/10's
<b>732-0002</b>	Flush-Rectangular, 10-80VDC, ¼" [6.3mm] spade terminals, hours & 1/10's
<b>732-0003</b>	Flush-Round, 10-80VDC, ¼" [6.3mm] spade terminals, hours & 1/10's
<b>732-0004</b>	2-Hole Rectangular, 10-80VDC, ¼" [6.3mm] spade terminals, hours & 1/10's

**5003-007S** NEMA 4X, 12 Gasket kit and hardware for 3-Hole Round model (732-0001)

\* All items are normally in factory stock.



Dimensions

2-Hole

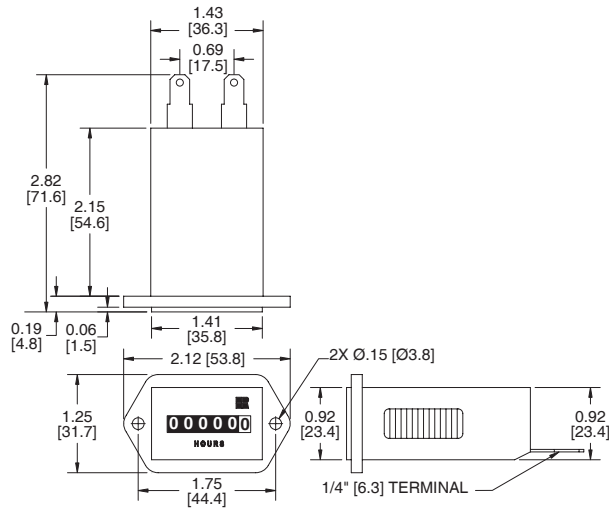

Panel Opening: 1.45" X 0.95" [36.8 X 24.1]

Flush-Rectangular

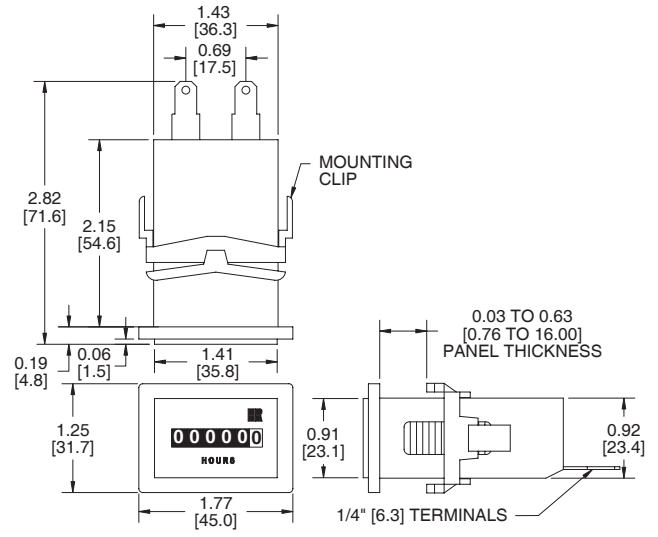

Panel Opening: 1.45" X 0.95" [36.8 X 24.1]  
Maximum Panel Thickness: 0.03 to 0.63 [0.76 to 16.00]

Flush-Round

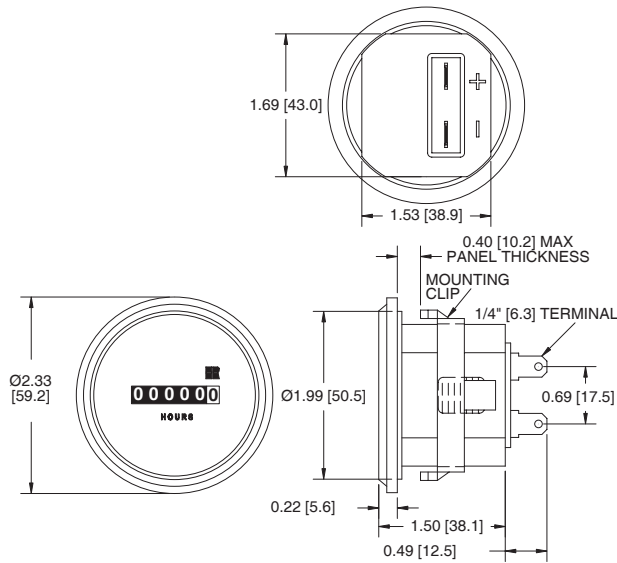

Panel Opening: 2.0" [50.6]  
Maximum Panel Thickness: 0.40 [10.2]

3-Hole Round

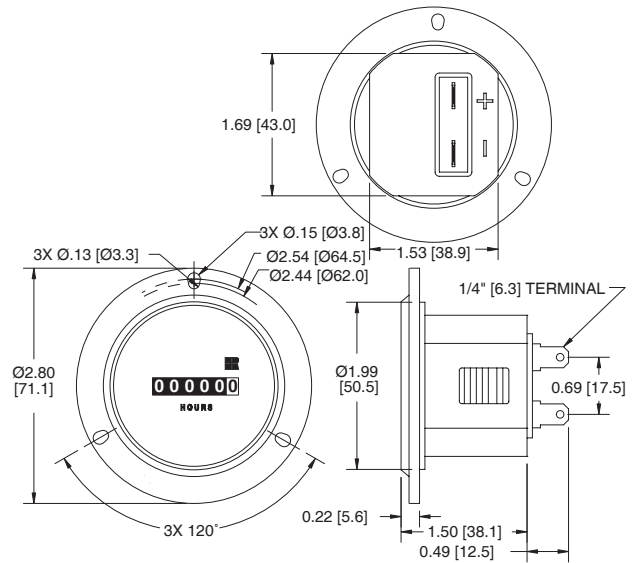

Panel Opening: 2.0" [50.6]

Applications

Medical Equipment



Outdoor power equipment



Utility Vehicles





Description

The Model 53 Tachometers are self-powered by an internal lithium battery. They provide a low cost solution to accurately measure speed or production rates for a number of manufacturing and process applications. A wide selection of inputs, dry contact closure, 3-30VDC or 20-250VAC/VDC, make the Model 53 adaptable to most applications. When used with the appropriate sensor, the unit can display units per minute, length per minute or revolutions per minute. The maximum input rate is 10,000 counts per minute.

Features

- Lithium battery
- Choice of non-reset or remote reset
- Switch (no-voltage), 3-30VDC, 20-250VAC/VDC

Options

- Termination
- Case color
- Private labeling
- Mounting adapter plates
- 5003-001S - gasket

Specifications

**Figures:** 4 LCD figures, 0.32" [8mm] high  
**Reset:** Remote, manual, or non-reset  
**Speed:** 10,000 counts/minute  
**Inputs:** Switch (no-voltage), 3-30VDC, 20-250VAC/VDC  
**Power:** Self-powered (internal lithium battery)  
**Mounting:** Panel  
**Terminations:** Terminal block, or connector -w/ 8" [200mm] wire leads  
**Battery Life:** ~20years  
**Temperature:**  
**Operating:** -4°F to +140°F [-20°C to +60°C]  
**Storage:** -40°F to +165°F [-40°C to +75°C]

**Humidity:** 0 to 95% RH, non-condensing  
**Vibration:**  
**Operating:** 10 to 55Hz, 0.01" [0.25mm] double amplitude  
**Non-Operating:** 10 to 55Hz, 0.03" [0.75mm] double amplitude  
**Shock:**  
**Operating:** 10G  
**Non-Operating:** 30G  
**Dielectric:** 1000VAC 50/60Hz for 1 minute  
**Accuracy:** Typically within 1% above 700Hz  
**Weight:** 2 oz. [57g]  
**Approvals:** UL Recognized, CSA Certified, CE Compliant

Models

Models	Reset			Input			Speed/RPM		Terminations		Color	
	remote	none	manual	switch	3-30VDC	20-250VAC/VDC	10,000	2500	term. block	8" wire leads	Tan	Black
5330-0000	X			X			X		X		X	
5330-0001	X			X			X		X			X
5330-1000	X				X		X		X		X	
5330-1001	X				X		X		X			X
5330-2000	X					X		X	X		X	
5330-2001	X					X		X	X			X
5330-2200		X				X		X	X		X	
5330-2201		X				X		X	X			X

\* All part numbers shown are for 7 digit models. Please contact the factory for information on 8 digit models.

Dimensions

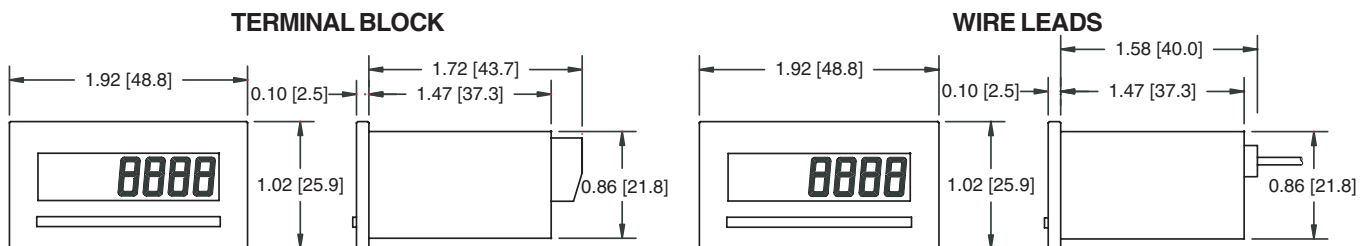



Operating Instructions

MOUNTING:

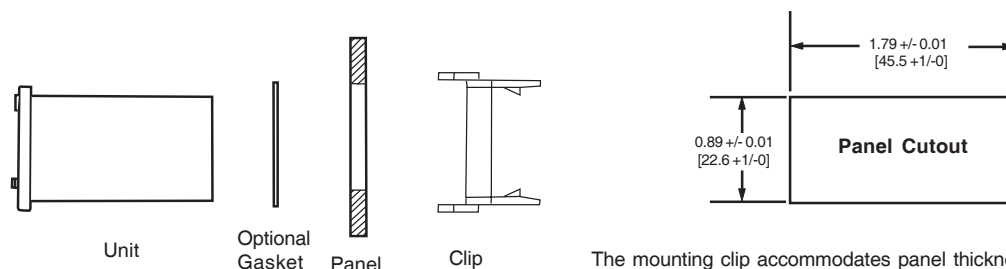

The mounting clip accommodates panel thicknesses up to 1/4" [6.4mm].

WIRING:

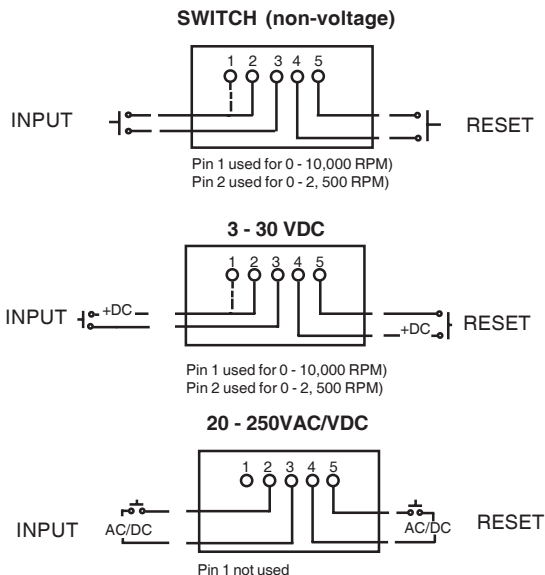

Panel adapter plates are available in flush and 2 hole mount to fit various panel cutouts. Consult the factory for availability.

Color code for the 8" [203mm] lead wires (24AWG) are:

- 1 - Yellow
- 2 - Blue
- 3 - Black
- 4 - Violet
- 5 - Gray

Terminal block will accept wire sizes from 14 to 24AWG.

3 - 30VDC units are protected for transient voltages up to 50 volts with pulse widths of up to 1 second at a 1% duty cycle (including reverse polarity).

The operating AC frequency range is 40 to 400Hertz.

NOTES:

All resettable hour meters can be reset by a pulse with a minimum duration of 6 milliseconds.

SPECIAL WIRING OPTION

There is an internal connection between pin 3 and pin 5, a single wire can be used by connecting it to either pin 3 or pin 5. This option **does not** apply for units with input of 20 - 250VAC/VDC or manual reset enable.

OPTIONAL INPUTS:

Optional control circuitry (such as transistors) may be used as inputs provided that such circuitry provides the required parameters of the model used.

Applications

Motor/pulley Speed

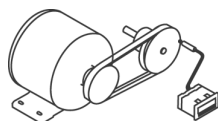



**Description**

The Model 85 is a 3 1/2 digit, Modular Digital Panel Meter, where input and output modules can be selected to suit multiple applications. Input Modules are available to indicate Voltage, Amperage, Pressure, Temperature, Rate, Ohms and Frequency. User -friendly programming allows the user to program scaling and set points. The Model 85 includes peak/valley (min/max) and password protection as standard features. The housing is easy to mount and ensures a protection degree of IP 65. The Model 85 can be ordered with or without Program Lock.

**Features**

- Modular Panel Meter 3 1/2 digit
- Optional bright red or green display
- Multirange input modules reduce inventory
- Popular 1/8 DIN mounting
- Indicating or controlling current, voltage, resistance, temperature, tachometer or frequency
- Easily programmed
- Optional password protection of programming parameters
- Data hold
- Peak/valley (min/max) function
- Programmable hysteresis and time delay (up to 2 set points)
- IP 65 front cover

**Options**

- Display color
- Output type
- Input voltage
- Value to display or control
- Program lock

**Specifications**

**General Specifications**

<b>Display:</b>	7-segment LED, 0.55" [14mm] high, (2 LED's for indication of relay ON). Min./max. indication, -1999/1999
<b>Over range indication:</b>	EE (under range: -EE)
<b>Accuracy:</b>	See module specifications
<b>Temperature drift:</b>	See module specifications
<b>Scaling:</b>	
Electrical input range:	Program within whole range
Display range:	Program within whole range
Decimal point position:	Programmable
<b>Module Connection:</b>	Screw terminals
<b>Environment:</b>	
Degree of protection:	IP 65 (front)
Operating temperature:	+32°F to +122°F [0°C to +50°C]
<b>Humidity:</b>	R.H. <90% non-condensing
Storage temperature:	+14°F to +140°F [-10°C to 60°C]
<b>Humidity:</b>	R.H. <90% non-condensing
<b>Weight:</b>	Approx. 12.4 oz [352g]
<b>Housing:</b>	
Dimensions:	1.9" x 3.9" x 3.5" [48.3 x 99.1 x 88.9mm]
<b>Material:</b>	
Housing:	ABS/Polycarbonate blend
Front:	Polycarbonate
Color:	Black housing Red front with red display Gray front with green display
<b>Approvals:</b>	UL, cUL, CE Compliant

**Power Supply Specification**

<b>Power Supply AC:</b>	Over voltage cat.III (IEC 60664)
Rated operational voltage:	230 VAC ± 10% 115 VAC ± 10% 48 VAC ± 10% 24 VAC ± 10%
Frequency:	50/60 Hz ± 5 Hz
Voltage interruption:	≤ 20ms
Rated insulation voltage:	250 VAC basic rms
Rated impulse withstand voltage:	6kV (1.2/50 msec) IEC 60664-1
<b>Power Supply DC:</b>	
Rated operational voltage:	12 to 48 VDC ± 15%
Voltage interruption:	≤ 10 ms (voltage = 10 VDC)
Rated insulation voltage:	150 VDC basic
Rated impulse withstand voltage:	4.0 kV (1.2/50 msec) IEC 60664-1
<b>Rated Operational Power:</b>	< 7 VA
<b>ECM:</b>	Electromagnetic compatibility
Immunity:	Acc. to IEC 60801-4 Acc. to IEC 60801-5



**Input Specifications - Modules**

**Voltmeters DC (85KSVD/85KLVD)  
AC (85KSVA/85KLVA)**

Measuring Range	Jumper position	Range Code		Resolution	Input Impedance	Max. Overload
		AC	DC			
199.9 mV	1-4	7	1	0.1 mV	100 KW	50 V
1.999 V	2-5	8	2	1 mV	100 KW	230 V
19.99	2-5	9	3	10 mV	1 MW	690 V
199.9 V	3-6	10	4	0.1 V	1 MW	690 V
600 V*	5-6	12	6	1 V	1 MW	690 V

\*Nominal voltage according to IEC 664-1. The measuring range includes 15% tolerance to 690 V.

**Accuracy**

AC voltmeter 0.3% of reading ± 3 dgt

DC voltmeter 0.2% of reading ± 2 dgt

**Temperature Drift**

AC voltmeter ± 150 ppm/°F ± 0.2 dgt/°F

DC voltmeter ± 100 ppm/°F ± 0.05 dgt/°F

**Ammeters DC (85KSCD/85KLCD)  
AC (85KSCA/85LCA)  
AC/DC (85KSAD/85KLAD)**

Measuring Range	Jumper position	Range Code		Resolution	Max. Overload
		AC	DC		
199.9 mA	1-2	7	1	0.1 mA	20 mA
1999 mA	2-3	8	2	1 mA	100 mA
19.99 mA	4-5	9	3	10 mA	200 mA
199.9 mA	5-6	10	4	0.1 mA	500 mA
1999 mA	2-5	11	5	1 mA	4 A
5.00 A	2-5	12	6	10 mA	8 A
10 A DC	1-2(DC)		6	10 mA	10 A
10 A AC	2-3(AC)	12		10 mA	10 A

**Accuracy**

AC ammeter 0.3% of reading ± 3 dgt

AC ammeter (10 A) 0.5% of reading ± 3 dgt

DC ammeter 0.2% of reading ± 2 dgt

DC ammeter (10 A) 0.5% of reading ± 2 dgt

**Temperature Drift**

AC ammeter ± 150 ppm/°F ± 0.5 dgt/°F

AC ammeter (2A,5A) ± 200 ppm/°F ± 0.1 dgt/°F

AC ammeter (10A) ± 200 ppm/°F ± 0.5 dgt/°F

DC ammeter ± 100 ppm/°F ± 0.05 dgt/°F

DC ammeter (2A,5A) ± 200 ppm/°F ± 0.5 dgt/°F

DC ammeter (10A) ± 200 ppm/°F ± 0.5 dgt/°F

**Voltage Drop**

<200 mV (all ranges)

**Pressure Indicator**

The Model 85 can be used to indicate pressure by using the DC Amperage or DC Voltage input module. You can then program the unit to limit the range to 20mA or 20VDC and program the engineering units to display the corresponding pressure reading.

**Ohmmeter (85KSIR/85KLIR)**

Measuring Ranges	Jumper position	Range Code AC	Resolution
199.9 W	1-4	7	0.1 Ω
1999 W	2-5	8	1 Ω
19.99 kW	3-6	9	0.01 kΩ
199.9 kW	1-2	10	0.1 kΩ

**Accuracy**

0.2% of reading ± 2 dgt

**Temperature Drift**

± 150 ppm/°F ± 0.1 dgt/°F

**Tachometers (85KSTK/85KLTK)**

Measuring	Jumper	Range	Resolution
199.9 RPM @ 30PPR*	J4, 1-2	7	0.1 RPM
199.9 RPM @ 60PPR*	J5, 1-2	8	0.1 RPM
199.9 RPM @ 100PPR*	J6, 1-2	9	0.1 RPM
1999 RPM @ 30PPR*	J4, 2-3	10	1 RPM
1999 RPM @ 60PPR*	J5, 2-3	11	1 RPM
1999 RPM @ 100PPR*	J6, 2-3	12	1 RPM

\* Pulses per revolution

**Input Selection**

Namur J1

NPN, PNP, Contact J2

**Accuracy**

1% of reading ±5 dgt

**Temperature Drift**

±200 ppm/°F

**Input Impedance**

Namur 1 kW

NPN, PNP, Contact 5 kW

**Time Constant (tc)**

1 sec.

**Frequency Meters (85KSFQ/85KLFQ)**

Measuring Ranges	Jumper Position	Range Code	Resolution
199.9 Hz	J7	7	0.1 Hz
1999 Hz	J8	8	1 Hz

**Input Selection**

Namur J1, J4 and J6

NPN, PNP, Contact J2 and J5

600 VAC J3

**Accuracy**

1% of reading ±5 dgt

**Temperature Drift**

±200 ppm/°F

**Input Impedance**

Namur 1 kW

NPN, PNP, Contact 5kW

600 VAC 600 kW

**Time Constant (tc)**

1 sec.



**Thermometers**

**Pt 100: RTD (85KSRT/85KLRT)**

Range	Resolution	Accuracy	Temperature Drift
-100.0 to 199.9 °C	0.1 °C	±0.2% of reading ± 2dgt	± 150 ppm/°C ± 0.05 dgt/°C
-148 to 199.9 °F	0.2 °F	±0.2% of reading ± 4 dgt	± 180 ppm/°F ± 0.10 dgt/°F
-148 to 392 °F	1 °F	±0.2% of reading ± 4 dgt	± 180 ppm/°F ± 0.10 dgt/°F

**Pt 100, 1562°F/850°C (85KSPT/85KLPT)**

Range	Resolution	Accuracy	Temperature Drift
-100.0 to 850 °C	1 °C	±0.2% of reading ± 3 dgt	± 150 ppm/°C ± 0.05 dgt/°C
-148 to 1562 °F	2 °F	±0.4% of reading ± 6 dgt	± 180 ppm/°F ± 0.10 dgt/°F

**Thermocouple type J (85KSJT/85KLJT)**

Range	Resolution	Accuracy	Temperature Drift
-100.0 to 760 °C	1 °C	±0.1% of reading ± 4 dgt	± 100 ppm/°C ± 0.05 dgt/°C
-148 to 1400 °F	1 °F	±0.1% of reading ± 8 dgt	± 180 ppm/°F ± 0.10 dgt/°F

**Thermocouple type K (85KSKT/85KLKT)**

Range	Resolution	Accuracy	Temperature Drift
-100.0 to 1250 °C	1 °C	±3% of reading ± 3 dgt	± 100 ppm/°C ± 0.05 dgt/°C
-100 to -50 °C	1 °C	±1% of reading +5/-1 dgt	± 100 ppm/°C ± 0.05 dgt/°C
-50.0 to 780 °C	1 °C	±0.1% of reading ± 3 dgt	± 100 ppm/°C ± 0.05 dgt/°C
780 to 1250 °C	1 °C	±0.25% of reading +1/-3 dgt	± 100 ppm/°C ± 0.05 dgt/°C
-148.0 to 1999 °F	2 °F	±3% of reading ± 6 dgt	± 180 ppm/°F ± 0.10 dgt/°F
-148 to -58 °F	2 °F	±1% of reading +10/-2 dgt	± 180 ppm/°F ± 0.10 dgt/°F
-58.0 to 1436 °F	2 °F	±0.1% of reading ± 6 dgt	± 180 ppm/°F ± 0.10 dgt/°F
1436 to 1999 °F	2 °F	±0.25% of reading +2/-6 dgt	± 180 ppm/°F ± 0.10 dgt/°F

**Output Specifications - Modules**

**Relay Outout 1 or 2 Relays (85KSR1/85KSR2)**

**Power Supply** Supplied by main unit  
**Output** 1 or 2 SPDT relays  
**Rated Insulation Voltage** 250 V basic RMS  
**Contact Ratings (AgCdO)**  
 Resistive AC 1 5A, 250 VAC  
 DC 1 5A, 24 VDC  
 Small inductive AC 11 2A, 250 VAC  
 loads DC 11 3A, 24 VDC  
**Mechanical Life** ≥ 40 x 10<sup>6</sup> operations  
**Electrical Life** ≥ 10<sup>5</sup> operations (at max load)  
**Operating Frequency** max. 10Hz (50% duty cycle)  
**Dielectric Strength**  
 Dielectric voltage 2 kVAC (rms)  
 Rated impulse withstand voltage 4 kV (1.2/50ms)

**NPN Output 2 Transistor Outputs (85KSNP)**

**NPN Open Collector:** I<sub>SNK</sub> = 100mA max. @ V<sub>OL</sub> = 1.0 VDC max.  
 V<sub>OHI</sub> = 30 VDC max.  
 12VDC/±15%, 40 mA,  
 voltage output is provided

**Excitation Output (85KSDC)**

**Power Supply** Supplied by main unit  
**Output Voltage**  
 12 VDC: jumper position 3-6 tolerance ±20%  
 24 VDC: jumper position 1-4 tolerance ±20%  
**Output Current**  
 12 VDC ≤ 35 mA DC  
 24 VDC ≤ 20 mA DC  
**EMC** Electromagnetic compatibility  
 Immunity Acc. to IEC 60801-4  
 Acc. to IEC 60801-5

**Analog output (85KSAN)**

Measuring Range	Load Resistance	Accuracy
0 to 20 mA	≤ 500 Ω	±1% of reading ±0.1 mA
4 to 20 mA	≤ 500 Ω	±1% of reading ±0.1 mA
0 to 10 V	≤ 1,000 Ω	±1% of reading ±0.05 V

**Temperature Drift** ±200 ppm/°C  
**Short-Circuit Protection** yes  
**Analog Output Porportional to Input Signal.**  
 low input signal = low analog output  
 high input signal = high analog output  
**Time Constant** 1 sec.





Operation Details

Operation Diagrams

Setpoint Operation

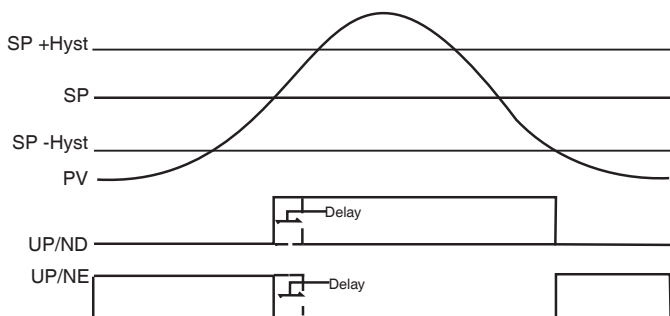

Output activates as input signal rises above setpoint (High Alarm)

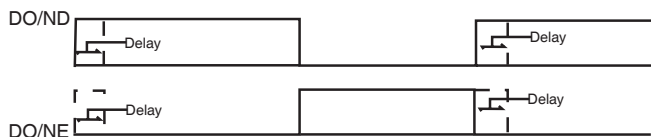

Output activates as input signal drops below setpoint (Low Alarm)

Scaling Operation

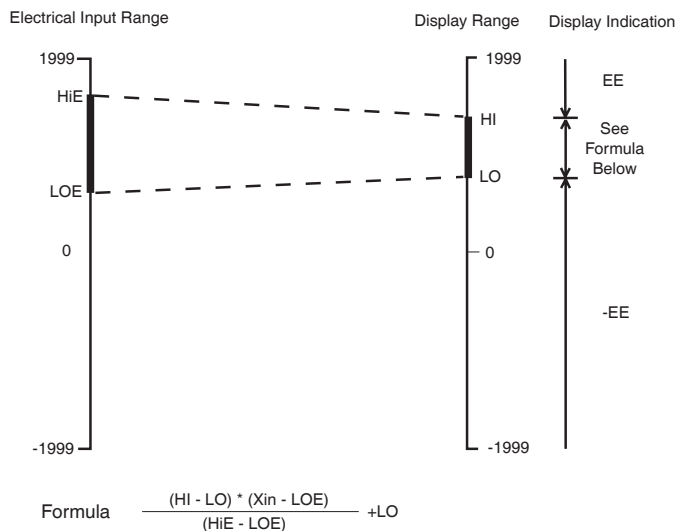

Mode of Operation

Depending upon the input modules used, it is possible to measure current, voltage, or resistance ...etc. The range is selected with a jumper on the input module and programming. Without an output module the Model 85 is an indicator - by inserting an output module the Model 85 is a controller.

The input range and the display range are fully programmable, and so are the setpoint(s) if a relay output module is inserted. A hold function is available for freezing a measured value. Passwords 0 to 99 are for overall programming with passwords 100 to 199 allow direct setpoint programming outside the password protection. See user manual for further details.

Overall Dimensions

Front View

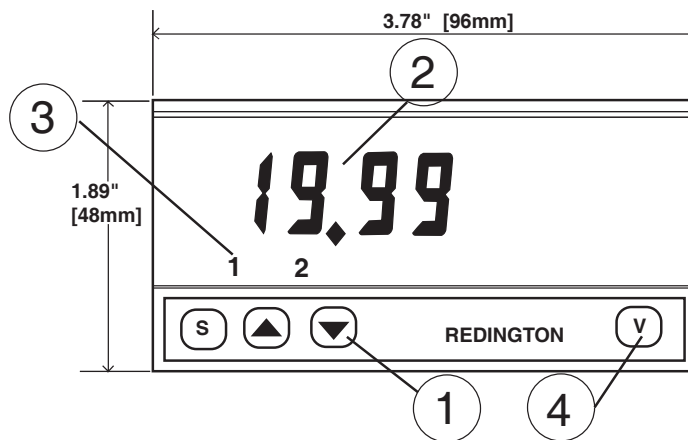

Panel Cutout 1.77" [45mm] X 3.62" [92mm]  
Cutouts can be up to .02" [0.5mm] larger

SideView

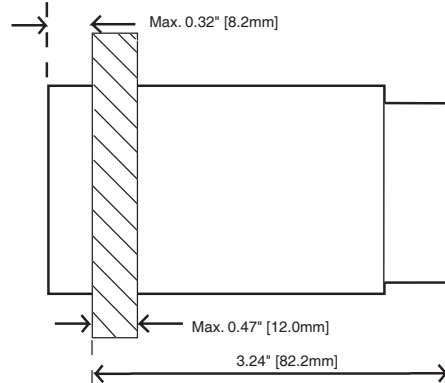



Rear view of main unit

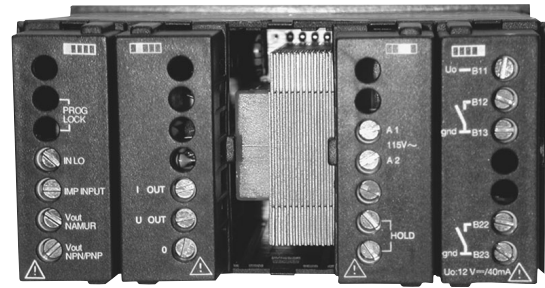
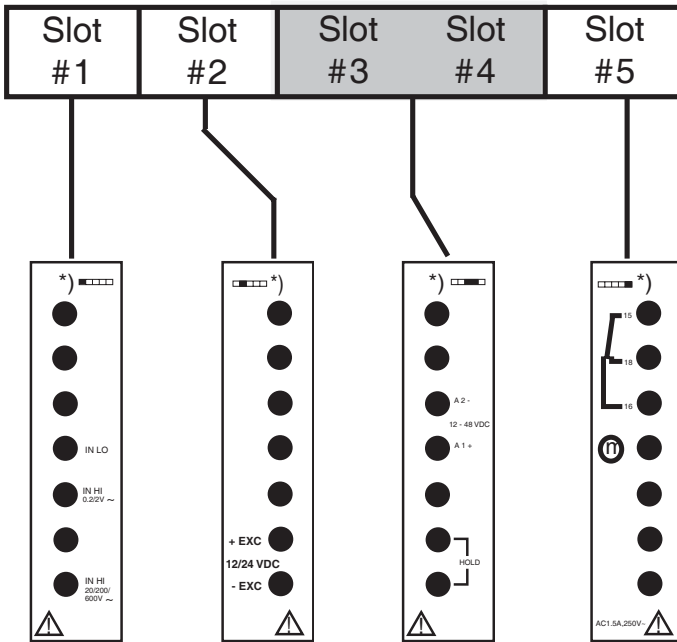

Rear View Assembled Unit

Module Slot Identification:

Each module is clearly marked with a diagram showing which slot it should be inserted in.

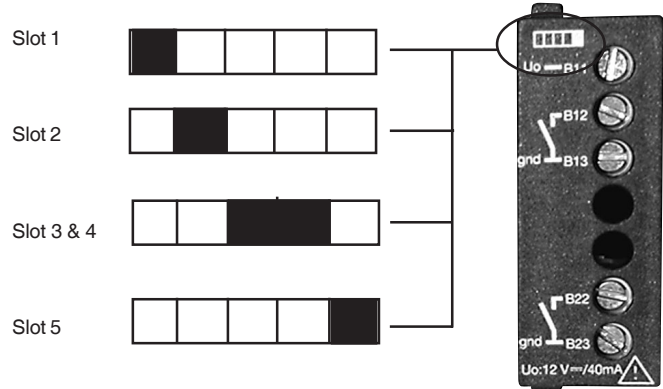

Input Module:

- VAC
- VDC
- AAC
- ADC
- 10A AC/DC
- W
- PT 100
- J-type Thermocouple
- K-type Thermocouple
- Tachometer
- Frequency

Output Modules:

- 12 VDC Excitation
- 24 VDC Excitation
- or
- Analog output
- 0-20 mA
- 4 - 20 mA
- 0 - 10 VDC

Power Supply Modules:

- (Requires 2 slots)
- 24 VAC
- 48 VAC
- 115 VAC
- 230 VAC
- 12 - 48 VDC

Relay Output Modules:

- 1 SPDT(Form C), 5A
- 2 SPDT(Form C), 5A
- 2 NPN

Red or Green Display Unit

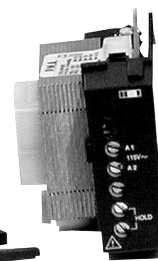
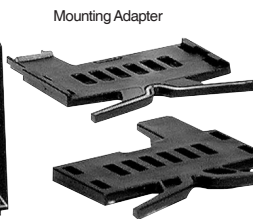

Power Supply Module

Relay/NPN Output Module



Blank Rear Inserts

Interchangeable Engineering Unit Labels

V	kV	A	mA	W	kW
k $\Omega$	Hz	kHz	$^{\circ}$ C	$^{\circ}$ F	%
mbar	bar	psi	kg/cm <sup>2</sup>	mm H <sub>2</sub> O	mm Hg
m <sup>3</sup> /h	mm	cm	m	Kg	kA
MW	$\Omega$	M $\Omega$	l/min	Kg/min	m <sup>3</sup> /min
RPM	kvar	m/min	ppm	cos $\phi$	



Applications

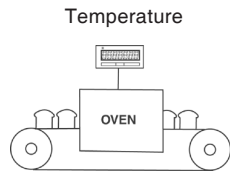

Volts/Amps/Ohms

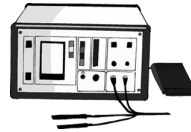

Speed Control

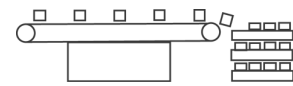

Ordering Information

Component Selection - Part Number

To order assembled (built-up) panel meters, see following "Part Number Selection" section.

To order components, select modules from each of the categories below to construct an Indicator or Controller. For additional guidance, consult the flowchart on the right.

Main Unit

- Red Display (standard red)
- Red Display (high efficiency red)
- Green Display

Ordering Number

- 85KSRD
- 85KSHR
- 85KSHG

w/Program Lock

Component Selection Flowchart

To build an indicator, choose display color, power supply, and input module. For a controller, also choose an analog/excitation output module.

Power Supply Modules

- 12 to 48 VDC
- 24 VAC
- 48 VAC
- 115 VAC
- 230 VAC

- 85KSP1
- 85KSP2
- 85KSP3
- 85KSP4
- 85KSP5

Input Modules

- DC Voltage
- AC Voltage
- DC Amperage
- AC Amperage
- AC/DC Amperage (10A)
- Resistance (Ohms)
- PT 100 RTD (can be scaled to °F)
- PT 100 RTD (up to 1562°F/850°C)
- J-Type Thermocouple (can be scaled to °F)
- K-Type Thermocouple (can be scaled to °F)
- Tachometer
- Frequency

- 85KSVD
- 85KSVA
- 85KSCD
- 85KSCA
- 85KSAD
- 85KSIR
- 85KSRT
- 85KSPT
- 85KSJT
- 85KSKT
- 85KSTK
- 85KSFQ

- 85KLVD
- 85KLVA
- 85KLCD
- 85KLCA
- 85KLAD
- 85KLIR
- 85KLRT
- 85KLPT
- 85KLJT
- 85KLKT
- 85KLTK
- 85KLFQ

Output Modules (optional)

- 1 Relay
- 2 Relays
- 2 NPN Transistors
- \*12/24 VDC Excitation Output/for sensor supply
- \*Analog Output

- 85KSR1
- 85KSR2
- 85KSNP
- 85KSDC
- 85KSAN

\*Analog and excitation output modules occupy the same plug-in location, therefore only one selection is possible.

\*Items in bold are normally in factory stock.

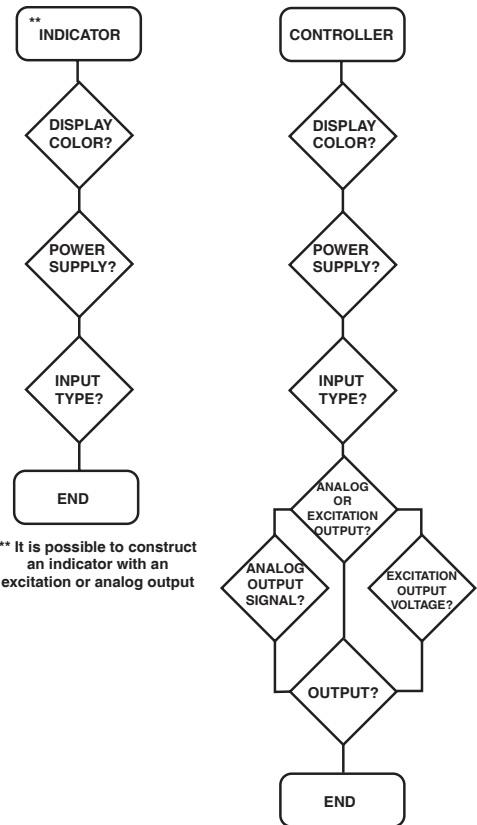



Part Number Selection - Assembled Unit(s)

Note: There is a 10 piece minimum of various assembled meters, not one specific part number.

Ordering Key

Model Number Model 85

Input Type and Range Code



DC Ammeters

Table with 2 columns: Model (CD1-CD7) and Range (-199.9 to +199.9 mA, etc.)

AC Ammeters

Table with 2 columns: Model (CA1-CA7) and Range (0 to 199.9 mA, etc.)

AC Voltmeters

Table with 2 columns: Model (VA1-VA5) and Range (0 to 199.9 mV, etc.)

\* Nominal voltage according to IEC60-664-1. The measuring range includes 15% tolerance equal to 690 V.

DC Voltmeters

Table with 2 columns: Model (VD1-VD5) and Range (-199.9 to +199.9 mV, etc.)

Ohmmeters

Table with 2 columns: Model (RO1-RO4) and Range (0 to 199.9 W, etc.)

Tachometer

Table with 2 columns: Model (TA1-TA6, TB1-TB6) and Range (8.0 to 199.9 RPM @ 30PPR, etc.)

Frequency Meters

Table with 2 columns: Model (FO1-FO2, FS1-FS2, F61-F62) and Range (5.0 to 199.9 Hz, etc.)

Thermometers

Table with 2 columns: Model (JC1, JF1, KC1, KF1, PC1-PC3, PF1-PF3) and Range (-100 to 760°C, etc.)

Power Supply

- 1) 12-48 VDC 2) 24 VAC 3) 48VAC 4) 115 VAC 5) 230 VAC

Relay Output

- N) None 1) One Relay 2) Two Relays 3) NPN

Output Modules

- N) None 1) 0-20mA 2) 4-20mA 3) 0-10 VDC 4) 12 VDC Excitation 5) 24 VDC Excitation

Display Color

- R) Red G) Green H) High Efficiency Red

Hardware Lock of Programming

- S) None L) Program Lock

Engineering Label

01 to 47 (see front panel description #4)



**Description**

The Model 88 is a family of LCD Indicators/Controllers, with eight 7-segment digits that are 0.35" [9mm] in height. The standard display is a backlit LCD, providing red characters on a dark background. An optional reflective LCD with dark characters on a light background is available. Unit programming is accomplished using four front-panel switches, or programming can be done using the optional serial data interface and dedicated PC-based software (Redi-Ware), which is available from Redington free of charge. Upon power up, the Indicator/Controller performs internal diagnostics and flashes all segments of the display "ON" and "OFF" several times. The Indicator/Controller then configures itself per previous programming, loads the internal Counters and Timers with their values prior to power down, and begins normal operation.

The Model 88 Indicator/Controller is capable of receiving counts and/or analog inputs, processing those inputs in a number of different selectable ways, and then providing outputs in several formats. Base units, i.e.; #8800-0000, or similar units can be programmed for Elapsed Time, Rate, Preset Count/Time, count Add/Add, count Add/Sub., or count Quadrature. The two independent control outputs are open-collector (NPN) outputs that can be controlled by either count inputs, time, the analog input, or combinations of the analog input/time and count inputs. Based on two inputs, the indicator is capable of displaying two counts, a rate indicator and an elapsed time at the same time. The base unit provides the display, programming, and processing functions for the final configuration as well as the counter I/O function. I/O functions and factory installed modules are available that allow the user to configure complex functions into a small enclosure. Other models add analog input/output functions to the base unit, and serial communication functions, which supports RS232/RS422/RS485, providing the user with a broad selection of configurations.

Each Model 88 base unit is normally powered from a DC voltage of +10V to + 32 V. However, an AC power supply module # 200557-002S can be attached to the rear of the unit that converts +90VAC to +250VAC, to +12VDC, which can be used to power the Model 88 and an external sensor. Another module, 200557-001S, can be added that converts the discrete outputs of the Model 88 base unit to relay contacts.

**Features**

- Dual up counting
- Preset of time, rate or count
- Directional counting
- 1,2,4x quadrature
- Add/add counting
- Add/subtract counting
- Rate indication on count inputs
- Analog ranges: 0 to 10 VDC or 4 to 20 mA
- Prescaling of analog inputs and counts
- Elapsed timer function available for all modes of operation
- NEMA 4X/IP56 sealed panel
- UL, cUL Recognized, CE Compliant UL file # E19514

**Options**

- Relay Module 200557-001S  
2 form C, 5 amp relays
- Serial Comm. (RS232, RS422, RS485)
- Analog input/outputs
- Display color
- AC Power Module 200557-002S  
+90 VAC to +285 VAC, 50/60 Hz (unit is normally powered from +10 VDC to +32 VDC)

**Specifications**

<b>Display:</b>	LCD, 8 digits, 0.35" [9mm] negative image transmissive red or positive image reflective display. In the negative count mode the display will be 7 digits with a "-" sign. (Reflective display recommended in sunlight)	Three different quadrature resolutions Add-Add Add-Subtract Dual Count Elapsed Time Analog Input Predetermining
<b>Annunciators:</b>	A, B, R, 1, 2 ANLG, LOCK, HZ, RPM, HRS, SEC. 0.039" [1mm]	
<b>Programming:</b>	Programming is accomplished through the front panel switches or by serial data interface and dedicated PC software, supplied by Redington Counters, Inc.	<b>Predetermining Functions:</b> Preset units provide two discrete outputs which can be controlled as a function of count, rate, elapsed time, or analog input. Each control output can be set by any of the four functions and reset by the same or a different function. For example, control output 1 could be set when a specific count is reached and reset when an analog input level is reached.
<b>Available Functions:</b>	Totalizer Directional Counting Rate/Count	



**Predetermining Timer:**

**Programmable Ranges:**  
Hours  
Seconds  
Hours, Minutes & Seconds

**Programmable Decimal Point:**

Counter A: 4 decimal point locations may be selected.  
Counter B: 4 decimal point locations may be selected.  
Rate Display: 4 decimal point locations may be selected.  
Analog Input: 4 decimal point locations may be selected.  
Time: 4 decimal point locations may be selected.

**Power Requirements:**

Base unit: +10VDC TO +32VDC @ 50mA max.  
Relay Module: Model 200557-001S; +10VDC to +32VDC @ 50mA, max.  
AC Power Supply: Model 200557-002S; +90VAC to +250 VAC 50/60 Hz @ 6 VA max.

**Memory:** Nonvolatile EEPROM retains all program parameters and values when power is removed. EEPROM provides 20 year data retention.

**Sensor Power:** +12VDC @ 100mA, minimum (200557-002S Module)

**Front Panel Lockout:**

Two front panel lockouts are available. In the programming mode, the operator is prohibited from entering new parameters. In the operating mode, the lockout disallows manual reset of any displayed inputs.

**Count/Timer Inputs (Input A & Input B):**

Software selectable: switch contact or voltage input  
Software Selectable: filter: no filter or 160 Hz 1<sup>st</sup> order LP.  
Voltage Mode  $V_{IH}$ : 2.4VDC, min.  
Voltage Mode  $V_{IL}$ : 0.8VDC, max. or open circuit  
Switch Mode  $V_{IH}$ : 2.4 VDC, min. or open circuit  
Switch Mode  $V_{IL}$ : 0.8VDC, max.  
Maximum Input voltage: 32.0VDC  
Minimum Input voltage: -0.8VDC

**Counter/Timer Operational Format:**

Input A is used for all count functions  
Input B is used for timer enable and all dual Input counter functions (i.e. ADD/ADD, ADD-SUB, DIRECTIONAL COUNT, QUADRATURE, and DUAL COUNT).

**Input Scaling:** A & B Counters and analog input, (- 9.9999 to 99.9999)

**Quadrature Counting:**  
Software selectable X1, 2, 4

**Analog Input:** 0 to 10VDC or 4 to 20 mA  
Resolution: 4 digit

**Input Impedence:**  
150K ohms, for 0 to 10VDC  
100 ohms, for 4 to 20 mA

**Max. Count Rate:** 40 KHz for single counter mode.  
20 KHz for dual count modes

**Rate Input Units:** The rate input can be expressed in terms of scaled counts per minute (rP) or scaled counts per second (HZ) of counter A.

**Rate Indicator Accuracy:**

±0.01%, References Time Base @T=25°C

**Minimum Input Frequency:**  
1 pulse in 10 seconds

**Maxium Input Frequency:** 40 K HZ

**Reset Functions:** (Automatic & manual)

**Reset-to-Zero:** Can be programmed so that the output activates when counter equals the preset value, counter returns to zero when reset.

**Reset-to-Preset:** Can be programmed so that the output activates when counter equals zero, Counter returns to Preset value when reset.

**Resets:** Automatic or manual.

**Outputs:** Base unit; Solid-state NPN: (2) Open collector:  $I_{SNK}=100mA$  @  $V_{OL}=1.1VDC$   $V_{OH}=40VDC$

**Relay Module:** Model 200557-001S; 2 form "C" relays rated @ 5 amps 250 VAC, 30VDC(resistive load) 1/10<sup>th</sup> HP @120VAC (inductive load)

**Relay Life Expectancy:**  
100,000 cycles min. @ max. rated load.

**Programmable Timed Outputs:**  
Both control outputs can be timed.

**Elapsed Timer Accuracy:** ± 0.01% @T=25°C

**Analog Output:** 0 TO 10VDC OR 4 TO 20mA  
**Accuracy:** 0.25% of full scale @ T = 25°C  
**Resolution:** 14 bits

**RS232/RS485/RS422 Serial Communications:** (Optional)  
**Baud Rate:** Selectable 2400, 4800, 9600, or 19.2K  
**Data Length/Parity/Stop Bits:** 8n1  
**RS485 Address:** Programmable from 0 to 99.  
**Transceiver Loading:** RS232/RS485/RS422- up to 16 loads

**Certifications & Compliances:**  
UL, cUL- Recognized Component, file # E 195514  
CE-Compliant to EN 61326: 1998 for industrial equipment

**Environmental Conditions:**  
**Operating Temperature:** -4°F to +140°F [-20°C to +60°C]  
**Storage Temperature:** -40°F to +185°F [-40°C to +85°C]  
**Operating & Storage Humidity:** to 95% (non-condensing) from -4°F to +140°F [-20°C to +60°C]  
**Altitude:** Up to 6561Ft. (2000 Meters)

**Electrical Connection:** Wire clamping screw terminals

**Construction:**  
High impact black plastic case with "Clip" type mount. Front panel meets NEMA 4X/IP65 requirements for indoors use, when properly installed. Oversized front panel flange insures proper sealing of panel cutouts. Gaskets for front panel are provided.

**Panel Thickness:** 0.05" to 0.20" [1.3 to 5.1mm]

**Weight:** Less than 3 oz. (85g)



Models Description

For Models and Descriptions see the Ordering Information section

Dimensions

Model 88

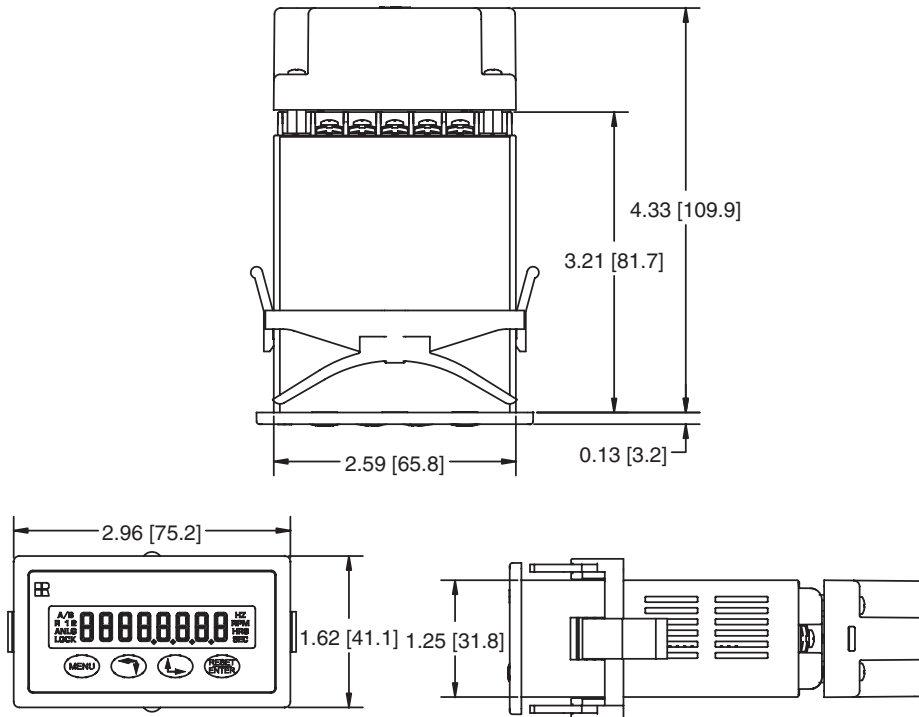

Panel Cutout 2.63" to 2.605" x 1.28" to 1.26" [66.8 to 66.2 x 32.5 to 32.0]  
Max. thickness of panel 0.5" [12.7]

Applications

Batching

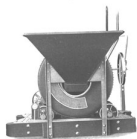

Cut-to-length

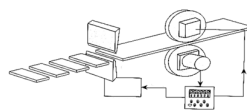

Elapsed time indicator

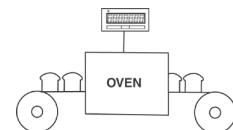

Flow and level control

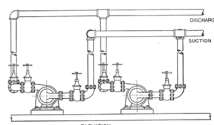

Rate/Indication or control

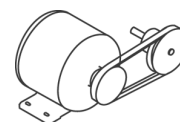



Ordering Information

MODEL NUMBER	DESCRIPTION	DISPLAY RED TRANSMISSIVE	DISPLAY REFLECTIVE	ANALOG INPUT	ANALOG OUTPUT	RS-485 RS-232 RS 422
8800-0000	Base unit, Red Trans., 10-30VDC, Prescale	X				
8810-0000	Base unit, Reflective, 10-30VDC, Prescale		X			
8800-0100	Red Trans., 10-30VDC, Prescale, Serial Communications	X				X
8810-0100	Reflective, 10-30VDC, Prescale, Serial Communications		X			X
8800-0010	Red Trans., 10-30VDC, Analog input, Prescale	X		X		
8810-0010	Reflective, 10-30VDC, Analog input, Prescale		X	X		
8800-0001	Red Trans., 10-30VDC, Analog output, Prescale	X			X	
8810-0001	Reflective, 10-30VDC, Analog output, Prescale		X		X	
8800-0110	Red Trans., 10-30VDC, Analog input, Prescale, Serial Communications	X		X		X
8810-0110	Reflective, 10-30VDC, Analog input, Prescale, Serial Communications		X	X		X
8800-0101	Red Trans., 10-30VDC, Analog output, Prescale, Serial Communications	X			X	X
8810-0101	Reflective, 10-30VDC, Analog output, Prescale, Serial Communications		X		X	X
8800-0011	Red Trans.,, 10-30VDC, Analog I/O, Prescale	X		X	X	
8810-0011	Reflective, 10-30VDC, Analog I/O, Prescale		X	X	X	
8800-0111	Red Trans, 10-30VDC, Analog I/O, Prescale, Serial Communications	X		X	X	X
8810-0111	Reflective, 10-30VDC, Analog I/O, Prescale, Serial Communications		X	X	X	X

ACCESSORIES

200557-001S Relay module            2 form C relays  
200557-002S AC Voltage module,    +90VAC to +250VAC also outputs +12VDC for base unit & sensor

Note: Reflective display is recommended for applications that will be exposed to direct sunlight

\* All parts are normally in factory stock.





**Description**

The 83 Counter features a 7 segment, 2 lines by 6-digit backlit LCD display. The main display line is red and shows the count value or the batch/total value when preset 3 or output 3 is viewed in the secondary display. The smaller secondary display line is green and can be used to view the prescaler value, preset values, output count values or batch/total count values (batch model only).

The 83 Counter offers a choice of nine programmable counting modes for use in applications requiring bidirectional, anti-coincidence, and quadrature counting. The unit may be programmed to detect counts on both edges of the input signal resulting in a doubling of frequency. DIP switches are used for input configuration setup and to provide a program disable function.

Four front panel push buttons are used for ease of programming the operating modes and data values, to change the viewed display, and performing user programmable functions, e.g. reset, etc. The 83 Counter can be configured for one of two numeric data entry methods.

Digital - The digital entry allows for the selection and incrementing of digits individually.

Automatic Scrolling - This method allows for the progressive change of one through all digits positions by pressing and holding the **up** or **down** button.

Protection of data value and unit configuration - The program disable DIP switch, a user-programmable code value, and an external user input selected for program disable can be utilized to provide multilevel protection.

The standard with dual presets is available with solid-state and relay outputs. The batch counter has relay outputs for output 2 and the batch/total output 3, with output 1 available as solid-state. For all 83 Counters, the solid-state outputs are available in a choice of NPN current sinking or PNP current sourcing, open- collector transistor outputs. All relay output boards are field replaceable.

Prescaler output is available as a dual preset, with solid-state outputs. The prescaler output is useful for providing a lower frequency scaled pulse train to a PLC or another external totalizer. The prescaler output provides a programmable width for every count or every 10 counts registered on the display

RS485 communications - optional serial communication capability allows for interrogation and modification of the preset, count and prescaler values.

Construction - The unit is made of lightweight, high impact plastic with a textured front panel and a clear display window. The front panel meets NEMA4X/IP65 specifications when properly installed. Multiple units can be stacked horizontally or vertically. SMT, extensive testing, plus high immunity to noise interference make the 83 Counter extremely reliable in industrial environments.

**Features**

**Options**

- Quadrature sensing
- Bidirectional counting, up/down control
- Count values to (999999)
- Prescaler output model (dual preset only)
- Field replaceable relay output boards
- Solid State and relay output models
- NEMA4X/IP65 sealed bezel
- Status indicators for outputs
- Security via programmable operator access privileges and protected values menu
- Programmable user inputs and front panel function key
- Horizontal or vertical stacking of multiple units
- 85 to 250VAC or 18 to 36VDC/24 VAC power units
- RS485 communications option
- Choice of numeric data entry modes

- Output type
- Serial communications
- Voltage input
- Display color
- Number of presets



**Display:** 2 line by 6 digits LCD display, negative image transmissive with RED (top line) and GREEN (bottom line) backlighting. Positive image reflective display units are non-stock available.

**Main:** 0.3" (7.6mm) high digits

**Secondary:** 0.2" (5mm) high digits

**Annunciators:**

**Value:** PRS, 1,2 and 3

**Output:** 01, 02 and 03

**POWER REQUIREMENTS:**

**AC Versions**

**AC Power:** 85 to 250 VAC, 50/60Hz, 9VA max.

**DC Power:** 11 to 14 VDC @ 159 mA max.  
(Non PNP output models)

Note: Models with PNP current sourcing outputs must be powered from AC

**DC Versions**

**DC Power:** 18 to 36 VDC: 5.5 W max.

**AC Power:** 24 VAC +/- 10%: 50/60 Hz: 7VA max.

Note: The 10% tolerance range on AC input voltage must be strictly adhered to DO NOT EXCEED 26.4 VAC

**PEAK (START-UP CURRENT)**

**AC or DC Power:** 500mA peak start-up current for 10 msec. max.

**DC OUT/ VSCR IN-terminal 10**

For units that do not have PNP current sourcing outputs, this terminal provides a DC output for sensor power + 12 VDC (+/- 15%). The maximum sensor current is 100mA.

For units with PNP current sourcing outputs this terminal serves a dual purpose depending on the application PNP output voltage level and current requirements.

- The terminal may be used as a +12 VDC output for sensor power. In this case, the PNP output voltage level will be +12 VDC (+/-15%). A maximum of 100 mA is available for the combination of sensor and PNP output sourcing current.
- If a higher PNP output voltage level or additional output sourcing current is needed, an external DC supply may be connected between the "DC OUT ( V SRC IN)" and "COMM." terminals. This supply will determine the PNP output voltage level, and must be in the same range of +13 to +30 VDC.  
An external DC supply can also provide the additional output sourcing current required in applications where two or more PNP outputs are "ON" simultaneously. However, the maximum current range of 100mA per individual output must not be exceeded, regardless of external supply capacity.

**3. Memory:** Nonvolatile FRAM retains all program parameters and count values.

**4. SENSOR POWER:** + 12 VDC (+/- 15%) @ 100mA max.

**5. COUNT INPUTS A & B:** Accepts count pulses from a variety of sources, DIP switch selectable.

**Current Sourcing: (active high):**  $V_{in,max} = 3.9K$  ohm pull-down to 30 VDC.

**Current Sinking: (active low):** 7.8 K ohm pull-up to 12 VDC :  $I_{snk} = 1.8mA$  max.

**Debounce :** 50 Hz

**Lo Bias:**  $V_{IL} = 1.5$  VDC max.,  $V_{IH} = 3.75$  VDC min.

**Hi Bias:**  $V_{IL} = 5.5$  VDC max.,  $V_{IH} = 7.5$  VDC min.

**6. MAX. COUNT RATE:** Model dependent. All listed values are in Khz. Note: Max. count rates for X2 & X4 modes are given for 50% duty cycle signals and quad signals with 90° phase shift.

**Single Preset Model 8301**

Prescaler Value	C1-Usr C1-Ud	C2-usr C2-Ud	*Ad-sub Ad-Ad	QUAD		
				X1	X2	X4
0.00001-0.99999	8.4	4.1	9.4	5.4	4.5	2.1
1.00000	12.0	5.9	12.4	6.5	6.0	3.0
1.00001-2	6.6	3.2	6.8	4.3	3.3	1.6
2.00001-3	5.3	2.6	5.6	3.7	2.6	1.3
3.00001-4	4.3	2.1	4.6	3	2.2	1.1
4.00001-5	3.6	1.8	3.8	2.7	1.8	0.9
5.00001-6	3.1	1.5	3.4	2.4	1.6	0.8
6.00001-7	2.8	1.4	3.2	2.1	1.4	0.7
7.00001-8	2.6	1.3	2.8	1.9	1.3	0.6
8.00001-9	2.3	1.1	2.4	1.8	1.1	0.5
9.00001-9.99999	2.1	1.0	2.3	1.7	1.1	0.5

**Dual Preset Model 8302**

Prescaler Value	C1-Usr C1-Ud	C2-usr C2-Ud	*Ad-sub Ad-Ad	QUAD		
				X1	X2	X4
0.00001-0.99999	8.3	4.1	8.6	4.5	4.1	2.1
1.00000	11.5	5.7	11.5	6.0	5.8	3.0
1.00001-2	6.5	3.2	6.6	4.0	3.2	1.6
2.00001-3	5.0	2.4	5.2	3.4	2.5	1.3
3.00001-4	4.1	2.0	4.4	2.8	2.0	1.0
4.00001-5	3.4	1.7	3.8	2.5	1.7	0.8
5.00001-6	2.9	1.4	3.2	2.2	1.4	0.7
6.00001-7	2.7	1.3	2.8	2.0	1.3	0.6
7.00001-8	2.2	1.1	2.4	1.8	1.2	0.6
8.00001-9	2.2	0.9	2.3	1.6	1.1	0.5
9.00001-9.99999	1.9	0.9	2.0	1.5	0.9	0.4

**Batch Model 8303**

With Counter 2 configured as a Batch Counter ( $C2 A5n = bAtch$ )

Prescaler Value	C1-Usr C1-Ud	C2-usr C2-Ud	*Ad-sub Ad-Ad	QUAD		
				X1	X2	X4
0.00001-0.99999	8.3	4.1	8.4	3.7	3.6	2.2
1.00000	11.4	5.5	11.8	4.3	4.2	3.0
1.00001-2	6.5	3.2	6.6	3.2	3.0	1.6
2.00001-3	5.0	2.5	5.4	2.8	2.5	1.3
3.00001-4	4.1	2.0	4.2	2.4	2.0	1.0
4.00001-5	3.4	1.7	3.8	2.1	1.7	0.8
5.00001-6	2.9	1.4	3.2	1.9	1.5	0.7
6.00001-7	2.7	1.3	2.8	1.7	1.3	0.6
7.00001-8	2.4	1.1	2.6	1.6	1.2	0.6
8.00001-9	2.2	1.1	2.4	1.5	1.1	0.5
9.00001-9.99999	1.9	0.9	2.2	1.4	1.0	0.4

**Batch Model 8303**

With Counter 2 configured as a Total Counter ( $C2 A5n = totAL$ )

Prescaler Value	C1-Usr C1-Ud	C2-usr C2-Ud	*Ad-sub Ad-Ad	QUAD		
				X1	X2	X4
0.00001-0.99999	6.5	3.3	6.6	3.5	3.3	1.6
1.00000	8.5	3.6	8.6	4.0	4.0	2.1

**Prescaler Output Model 8304**

Prescaler Value	C1-Usr C1-Ud	C2-usr C2-Ud	*Ad-sub Ad-Ad	QUAD		
				X1	X2	X4
0.00001-0.99999	6.2	N/A	N/A	N/A	N/A	N/A
1.00000	8.0	N/A	N/A	N/A	N/A	N/A

\* Inputs A & B rates summed.



7. USER INPUTS: Configurable as current sinking (active low), or current sourcing (active high) inputs via a single plug jumper.

Current Sinking: (active low) : VIL= 1.5 VDC max. 22 K ohm pull-ups to 5 VDC

Current Sourcing: (active high): VIH=3.5 min. VIN max. = 30 VDC; 22K ohm pull-down.

Response Time: 10 msec. max.

Inhibit Response Time: 250 microsec max.

8. OUTPUTS: (Output type and quantity model dependent)

Solid-State:

NPN Open Collector: ISNK= 100mA max. @ VOL = 1.1 VDC max. ;VOH= 30 VDC max.

PNP Open Collector: ISRC = 100mA max. ( See note) ; VOH = 12 VDC +/-15% ( using internal supply); VOH = 13 to 30 VDC ( using external supply).

Note: The internal supply of the 83 counter can provide a total of 100 mA for the combination of sensor current and PNP output sourcing current. The supply voltage is +12 VDC (+/-15 %), which will be the PNP output voltage level when using only the internal supply.

If additional PNP output sourcing current or a higher output voltage level is desired, an external DC supply may be connected between the "DC Out/In" and "Comm" terminals. This supply will determine the PNP output voltage level, and must be in range of +13 to 30 VDC.

An external supply can provide the additional output sourcing current required in applications where two or more outputs are "ON" simultaneously. However, the maximum rating of 100mA per individual output must not be exceeded, regardless of external supply capacity.

Relay: Form A contact, rating = 5 A @ 250 VAC, 30 VDC (resistive load) , 1/10 HP @ 120 VAC (inductive load).

Relay Life Expectancy: 100,000 cycles min. at max. load rating.

Programmable Timed Output: User selectable output time resolutions.

0.01 Second Resolution: 0.01 to 99.99 sec., +/-0.01% +20 msec max. (Prescalers less than 2)

0.1 Second Resolution: 0.1 to 999.9 sec. +/- 0.01 + 100 msec max. (Prescalers less than 2)

9. RS485 SERIAL COMMUNICATIONS (Optional): Up to 32 units can be connected.

Baud Rate: Programmable from 1200 to 9600 baud.

Address: Programmable from 0 to 99.

Data Format: 10 Bit Frame, 1 start bit , 7 or 8 data bits, 1 or no Parity bit, and 1 stop bit.

Parity: Programmable for Odd (7 data bits), Even ( 7 data bits) or None ( 8 data bits).

10. CERTIFICATIONS AND COMPLIANCES:

UL Recognized Component, File # E195514

Recognized to U.S. and Canadian requirements under the Component Recognition Program of Underwriters Laboratories, Inc.

CE Compliant:

ELECTROMAGNETIC COMPATIBILITY

Immunity to EN 50082-2

Table with 2 columns: Immunity type and EN standard number.

Emissions to EN 50081-2

Table with 2 columns: Emission type and EN standard number.

11. ENVIRONMENTAL CONDITIONS:

Operating Temperature: +32°F to +122°F [0°C TO +50°C]

Storage Temperature: -40°F to +158°F [-40°C to +70°C]

Operating and Storage Humidity: 85% max. relative humidity ( non-condensing) from +32°F to +122°F [0°C to +50°C]

Altitude : Up to 6500 Feet [1981 Meters]

12. ELECTRICAL CONNECTIONS: Wire clamping screw terminals.

13. CONSTRUCTION: Black plastic case with collar style panel latch.

The panel latch can be installed for horizontal or vertical stacking. Black plastic textured bezel can be removed from the case without removing the case from the panel or disconnecting the wiring. Front panel meets NEMA4X/IP65 requirements for indoor use, when properly installed. Installation Category II, Pollution Degree 2.

14. WEIGHT: 6.0 oz [170g]

SINGLE PRESET MODELS

The 8301 has a solid-state output that operates in parallel with a relay output. The solid-state output is available as an NPN or PNP open collector transistor.

DUAL PRESET MODELS

The 8302 has two outputs that are activated from presets 1 and 2. These outputs can be relay or solid-state outputs. The solid-state outputs are available as NPN or PNP open-collector transistors. Units with solid-state outputs can be ordered with an optional prescaler output.

3 PRESET BATCH MODELS

The 8303 has a secondary counter that can be used for batch counting, or to keep a total count. This second counter can be programmed to operate in one of eight operating modes. Output 1 and 2 are assigned to the primary process counter (C1). Output 3 is assigned to the secondary Batch/Total counter (C2). The three preset batch unit can be ordered with solid-state or relay outputs. Units with solid-state output have a User Input 2 terminal available. The relay model has a relay output for Output 2 and Output 3 (Batch/Total). Output 1 is available only as solid-state.

PRESCALER OUTPUT MODELS

The 8304 is a dual preset counter with solid-state outputs. These models have an additional output configured as a prescaler output. Each time the least significant digit of the display increments, the Prescaler output provides a pulse. The width of this pulse is variable in that the output will turn off after a programmed number of count input pulses has occurred (1-9). The Prescaler output can also be programmed to activate when the 10's digit of the display increments, rather than the least significant digit.

Note: Prescaler Output Models are limited to two programmable count modes and prescaler values of 1.00000 or less. See Count Input Modes for available modes.

FRONT PANEL KEYPAD



- Performs user Programmed Function.



- Cycles through secondary displays.
- Enters Programming Mode or Protected Value Menu when pushed and held for 2 seconds.
- Scrolls through programming displays.
- Enters Data Values.



- Selects next available mode in programming mode.
- Increments digit in digit Entry mode.
- Increments value in Auto Scrolling entry mode.



- Selects Digit to right when in Digit Entry mode.
- Decrements value in Auto Scrolling entry mode.



Models Description

For Details on Models and Descriptions, see the Ordering Information section

Dimensions

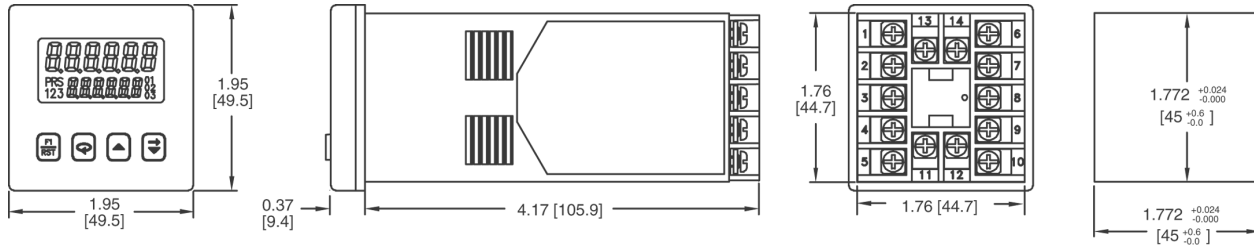

MULTIPLE UNIT STACKING

The Model 83 is designed for close spacing of multiple units. Units can be stacked either horizontally or vertically. For vertical stacking, install the panel latch with screws to the sides of the unit. For horizontal stacking, the panel latch screws should be at the top and bottom of the unit. The minimum spacing from center line to center line of the units is 1.96" (49.8 mm). This spacing is the same for vertical or horizontal stacking.

Note: When stacking units, provide adequate panel ventilation to ensure that the maximum operating temperature range is not exceeded.

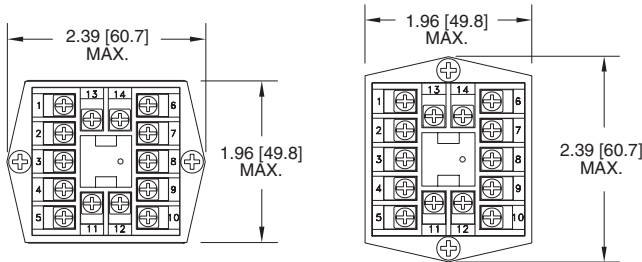

PANEL LATCH INSTALLED FOR VERTICAL UNIT STACKING

PANEL LATCH INSTALLED FOR HORIZONTAL UNIT STACKING

PANEL CUTOUT SPACING FOR MULTIPLE UNIT STACKING. HORIZONTAL ARRANGEMENT SHOWN.

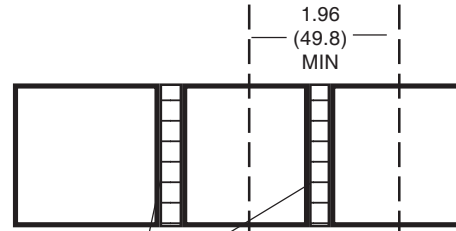

IF NEMA 4 IS NOT REQUIRED, THIS PANEL MATERIAL MAY BE REMOVED.

Applications

Convert-

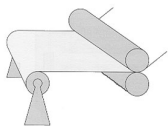

Batching

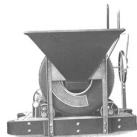

Cut-to-length

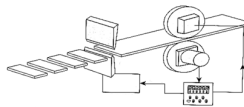

Packaging





**Ordering Information**

MODEL NO.	DESCRIPTION	NPN O.C. OUTPUT(S)	*PNP O.C. OUTPUT(S)	RELAY OUTPUT(S)	RS485	PART NUMBERS FOR AVAILABLE SUPPLY VOLTAGES	
						18-36 VDC/24 VAC	85 TO 250 VAC
8301	1 Preset Counter Backlit LCD	Yes	No	Yes	No	<b>8301-0110</b>	<b>8301-1110</b>
8302	2 Preset Counter Backlit LCD	Yes	No	No	No	<b>8302-0100</b>	8302-1100
	2 Preset Counter Backlit LCD	Yes	No	No	Yes	<b>8302-0101</b>	<b>8302-1101</b>
	2 Preset Counter Backlit LCD	No	No	Yes	No	<b>8302-0010</b>	<b>8302-1010</b>
	2 Preset Counter Backlit LCD	No	No	Yes	Yes	<b>8302-0011</b>	<b>8302-1011</b>
8304	2 Preset Counter w/Prescaler Output Backlit LCD	Yes	No	No	No	<b>8304-0100</b>	<b>8304-1100</b>
	2 Preset Counter w/Prescaler Output Backlit LCD	Yes	No	No	Yes	<b>8304-0101</b>	<b>8304-1101</b>
8303	3 Preset Batch Counter Backlit LCD	Yes(01)	No	Yes	No	<b>8303-0110</b>	<b>8303-1110</b>
	3 Preset Batch Counter Backlit LCD	Yes(01)	No	Yes	Yes	<b>8303-0111</b>	<b>8303-1111</b>
	3 Preset Batch Counter Backlit LCD	Yes	No	No	No	<b>8303-0100</b>	<b>8303-1100</b>
	3 Preset Batch Counter Backlit LCD	Yes	No	No	Yes	<b>8303-0101</b>	<b>8303-1101</b>

*Note: On batch Relay Models, Outputs 2 and 3 are relays, and Output 1 (01) is a solid-state output.*

\* PNP outputs are non-stock items

\* Items in bold are normally in factory stock.

**RELAY OUTPUT BOARDS**

DESCRIPTION	NPN O.C.	* PNP O.C.	RELAY	PART NUMBER
Single Preset	Yes	No	Yes	1726-044S
Dual Preset	No	No	Yes	1726-045S
Batch	Yes	No	Yes	1726-046S



**Description**

The Model 83 Timer is available in single or dual preset models. The 83 Timer features a 7 segment, 2 lines by 6-digit backlit LCD display. The main display line is red and shows the timer value. The smaller secondary display line is green and can be used to view the preset values or output time values.

The 83 Timer can be configured for a variety of different operating modes to meet most timing application requirements. Twelve timing ranges are available from thousands of a second to hours and minutes. Decimal points are used to separate the time units (hours, minutes, seconds). Timing can be cumulative or can reset and start upon each power cycle. "on delay" or "off delay", "single shot", "repetitive auto cycling" modes are all supported.

The 83 Timer can also be configured to continue or stop timing upon reaching preset. The display can be programmed to stop at the preset value (reset to zero mode) or zero (reset to preset mode), or automatically reset to zero or preset and hold. Once stopped, the timer can be restarted by manually resetting it, or it can be programmed to restart when power is reapplied. The 83 Timer has a run/stop input, 3 programmable user inputs, and a programmable front panel function key. The run/stop and user inputs can be configured as sinking (active low) or sourcing (active high) inputs via a single plug jumper. The user inputs and the front panel function key can be configured to provide a variety of functions.

Four front panel push-buttons are used for ease of programming the operating modes and data values, changing the viewed display, and performing user programmable functions, e.g. reset, etc. The 83 Timer can be configured for one of two numeric data entry methods digit or automatic scrolling.

Digital - The digital entry allows for the selection and incrementing of digits individually.

Automatic scrolling - This method allows for the progressive change of one through all digits positions by pressing and holding the **up** or **down** button.

The dual preset models are available with solid-state or relay outputs. The single preset model has a solid-state and relay output in parallel. All solid-state outputs are available in a choice of NPN current sinking or PNP current sourcing, open-collector transistor outputs. All relay output boards are field replaceable.

RS485 communications - optional serial communication capability allows for interrogation and modification of the preset, and timer values.

Construction- The unit is made of lightweight, high impact plastic with a textured front panel and a clear display window. The front panel meets NEMA4X/IP65 specifications when properly installed. Multiple units can be stacked horizontally or vertically. SMT, extensive testing, plus high immunity to noise interference make the 83 Timer extremely reliable in industrial environments.

**Features**

**Options**

- Displays values to (999999)
- 12 timing ranges
- Field replaceable relay output boards
- Solid state and relay output models
- NEMA4X/IP65 sealed bezel
- Status indicators for outputs
- Security via programmable operator access privileges and protected values menu
- Programmable user inputs and front panel function key
- Horizontal or vertical stacking of multiple units
- 85 to 250VAC or 18 to 36VDC/24 VAC power units
- RS485 communications option
- Choice of numeric data entry modes

- Output type
- Serial communications
- Voltage input
- Display color
- Number of presets



**Specifications**

**Display:** 2 line by 6 digits LCD display, negative image transmissive with RED (top line) and GREEN (bottom line) backlighting. Positive image reflective display units are non-stock available.

**Main:** 0.3" (7.6mm) high digits  
**Secondary:** 0.2" (5mm) high digits

**Annunciators:**  
**Value:** PRS, 1, and 2  
**Output:** 01 and 02

**POWER REQUIREMENTS:**

**AC Versions**

**AC Power:** 85 to 250 VAC, 50/60Hz, 9VA max.  
**DC power:** 11 to 14 VDC @ 159 mA max. (Non PNP output models)

*Note: Models with PNP current sourcing outputs must be powered from AC*

**DC Versions**

**DC Power:** 18 to 36 VDC: 5.5 W max.  
**AC Power:** 24 VAC +/- 10%: 50/60 Hz: 7VA max.

*Note: The 10% tolerance range on AC input voltage must be strictly adhered to > DO NOT EXCEED 26.4 VAC*

**PEAK (START-UP CURRENT)**

**AC or DC Power:** 500mA peak start-up current for 10 msec. max.

**DC OUT/ VSCR IN-terminal 10**

For units that do not have PNP current sourcing outputs, this terminal provides a DC output for sensor power (+ 12 VDC +/-15%). The maximum sensor current is 100mA. For units with PNP current sourcing outputs this terminal serves a dual purpose depending on the application PNP output voltage level and current requirements.

1. The terminal may be used as a +12 VDC output for sensor power. In this case, the PNP output voltage level will be +12 VDC (+/-15%). A maximum of 100 mA is available for the combination of sensor and PNP output sourcing current.
2. If a higher PNP output voltage level or additional output sourcing current is needed, an external DC supply may be connected between the "DC OUT" ( V SRC IN) and "COMM." terminals. This supply will determine the PNP output voltage level, and must be in the same range of +13 to +30 VDC.  
 An external DC supply can also provide the additional output sourcing current required in applications where two or more PNP outputs are "ON" simultaneously. However, the maximum current range of 100mA per individual output must not be exceeded, regardless of external supply capacity.

**3. MEMORY:** Nonvolatile FRAM retains all program parameters and Timer values.

**4. SENSOR POWER:** +12 VDC (+/- 15%) @ 100mA max.

**5. INPUTS:** Run/Stop, Usr. In1, Usr. In2, and Usr. In3.  
 Configurable as current sinking (active low), or current sourcing (active high) inputs via a single plug jumper.

**Current Sinking: (active low) :**  
 $V_{IL} = 1.5 \text{ VDC max. } 22 \text{ K ohm pull-ups to } 5 \text{ VDC}$

**Current Sourcing: (active high):**  $V_{IH} = 3.5 \text{ min.}$   
 $V_{IN} \text{ max.} = 30 \text{ VDC; } 22\text{K ohm pull-down.}$

**Run/Stop Response Time :** 250 microseconds max.

**User Input Response Time:** 5 msec. max.

**6. TIME ACCURACY:** +/- 0.01%

**7. OUTPUTS:** ( Output type and quantity model dependent)

**Solid-State:**

**NPN Open Collector:**

$I_{SNK} = 100\text{mA max. @ } V_{OL} = 1.1 \text{ VDC max.};$   
 $V_{OH} = 30 \text{ VDC max.}$

**PNP Open Collector:**

$I_{SRC} = 100\text{mA max. ( See note) ; } V_{OH} = 12 \text{ VDC +/-15%}$   
 ( using internal supply);  $V_{OH} = 13 \text{ to } 30 \text{ VDC ( using external supply).}$

*Note: The internal supply of the 83 Timer can provide a total of 100 mA for the combination of sensor current and PNP output sourcing current. The supply voltage is +12 VDC (+/-5 %), which will be the PNP output voltage level when using only the internal supply.*

*If additional PNP output sourcing current or a higher output voltage level is desired, an external DC supply may be connected between the " DC Out/In" and "Comm" terminals. This supply will determine the PNP output voltage level, and must be in range of +13 to 30 VDC.*

*An external supply can provide the additional output sourcing current required in applications where two or more outputs are "ON" simultaneously. However, the maximum rating of 100mA per individual output must not be exceeded, regardless of external supply capacity.*

**Relay:** Form A contact, rating = 5 A @ 250 VAC, 30 VDC (resistive load) 1/10 HP @ 120 VAC (inductive load).

**Relay Life Expectancy:**

100,000 cycles min. at max. load rating.

**Programmable Timed Output:**

User selectable output time resolutions.

**0.01 Second Resolution:** 0.01 to 99.99 sec., +/- 0.01% +10 msec max.

**0.1 Second Resolution:** 0.1 to 999.9 sec. +/- 0.01 % +100 msec max.

**8. RS485 SERIAL COMMUNICATIONS (Optional):**

Up to 32 units can be connected.

**Baud Rate:** Programmable from 1200 to 9600 baud.

**Address:** Programmable from 0 to 99

**Data Format:** 10 Bit Frame, 1 start bit , 7 or 8 data bits, 1 or no Parity bit, and 1 stop bit.

**Parity:** Programmable for Odd (7 data bits), Even ( 7 data bits) or None ( 8 data bits).

**9. CERTIFICATIONS AND COMPLIANCES:**

**UL Recognized Component, File # E195514**

Recognized to U.S. and Canadian requirements under the Component Recognition Program of Underwriters Laboratories, Inc.

**CE COMPLIANT :**

ELECTROMAGNETIC COMPATIBILITY

**Immunity to EN 50082-2**

electrostatic discharge	EN 61000-4-2
electromagnetic RF fields	EN 61000-4-3
fast transients	EN 61000-4-4
RF conducted interference	EN 61000-4-6
simulation of cordless phone	ENV50204

**Emissions to EN 50081-2**

RF interference	EN 55011	enclosure class A
-----------------	----------	-------------------

**10. ENVIRONMENTAL CONDITIONS:**

**Operating Temperature:** +32°F to +122°F [0°C to +50°C]

**Storage Temperature:** -40°F to +158°F [-40°C to +70°C]



**Operating and Storage Humidity:**

85% max. relative humidity ( non-condensing) from +32°F to +122°F [0°C to +50°C]

**Altitude:** Up to 6500 Feet

**13. WEIGHT:** 6.0 oz [170g]

**SINGLE PRESET MODELS**

The 8321 Timer offers a choice of twelve timing ranges with eighteen different operating modes. The unit has a solid-state output that operates in parallel with a relay output. The solid-state output is available as an NPN or PNP open collector transistor.

**DUAL PRESET MODELS**

The 8322 Timer offers a choice of twelve timing ranges with 44 operating modes. The unit is available with solid-state or relay outputs. The solid-state outputs are available as NPN or PNP open collector transistors.

**11. ELECTRICAL CONNECTIONS:**

Wire clamping screw terminals.

**12. CONSTRUCTION:** Black plastic case with collar style panel latch.

The panel latch can be installed for horizontal or vertical stacking. Black plastic textured bezel can be removed from the case without removing the case from the panel or disconnecting the wiring. Front panel meets NEMA4X/IP65 requirements for indoor use, when properly installed. Installation Category II, Pollution Degree 2.

**Models Description**

For Details on Models and Descriptions, see the Ordering Information section

**Dimensions**

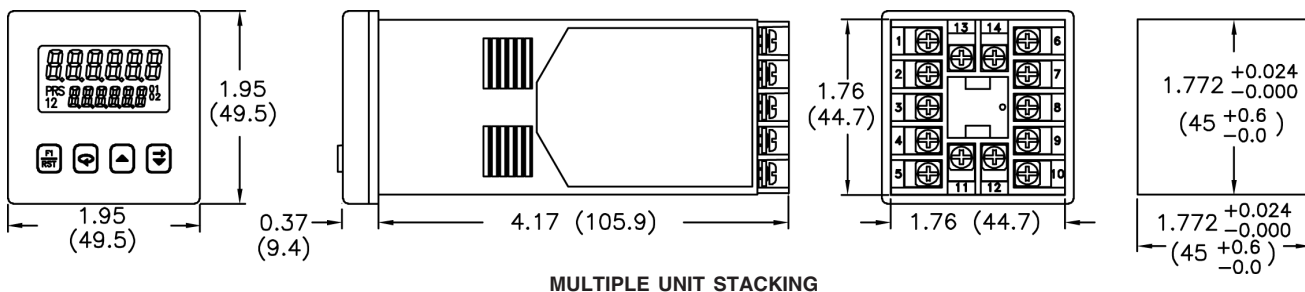

The Model 83 is designed for close spacing of multiple units. Units can be stacked either horizontally or vertically. For vertical stacking, install the panel latch with screws to the sides of the unit. For horizontal stacking, the panel latch screws should be at the top and bottom of the unit. The minimum spacing from center line to center line of the units is 1.96" (49.8 mm). This spacing is the same for vertical or horizontal stacking.

*Note: When stacking units, provide adequate panel ventilation to ensure that the maximum operating temperature range is not exceeded.*

**PANEL CUTOUT SPACING FOR MULTIPLE UNIT STACKING. HORIZONTAL ARRANGEMENT SHOWN.**

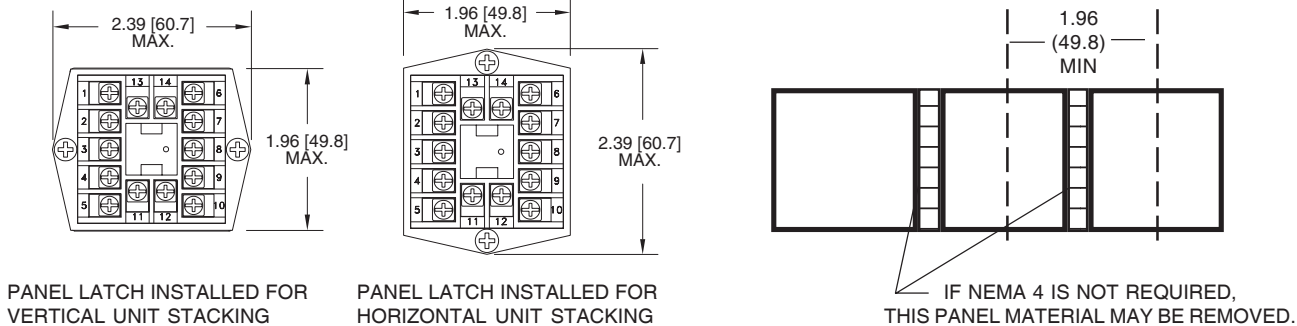

PANEL LATCH INSTALLED FOR VERTICAL UNIT STACKING

PANEL LATCH INSTALLED FOR HORIZONTAL UNIT STACKING

**Applications**



Mixing

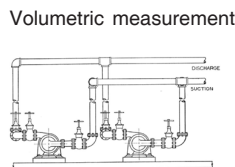

Volumetric measurement



Batch Control





Ordering Information

MODEL NO.	DESCRIPTION	NPN O.C. OUTPUT(S)	* PNP O.C. OUTPUT(S)	RELAY OUTPUT(S)	RS485	PART NUMBERS FOR AVAILABLE SUPPLY VOLTAGES	
						18-36 VDC/24 VAC	85 TO 250 VAC
8321	1 Preset Timer Backlit LCD	Yes	No	Yes	No	8321-0110	<b>8321-1110</b>
8322	2 Preset Timer Backlit LCD	No	No	Yes	No	<b>8322-0010</b>	<b>8322-1010</b>
	2 Preset Timer Backlit LCD	No	No	Yes	Yes	<b>8322-0011</b>	<b>8322-1011</b>
	2 Preset Timer Backlit LCD	Yes	No	No	No	<b>8322-0100</b>	<b>8322-1100</b>
	2 Preset Timer Backlit LCD	Yes	No	No	Yes	8322-0101	<b>8322-1101</b>

- \* PNP Outputs are non-stock items
- \* Items in bold are normally in factory stock.

RELAY OUTPUT BOARDS

DESCRIPTION	NPN O.C.	* PNP O.C.	RELAY	PART NUMBER
Single Preset	Yes	No	Yes	1726-044S
Dual Preset	No	No	Yes	1726-045S
3 Preset	Yes	No	Yes	1726-046S

- \* PNP Outputs are non-stock items



**Description**

The Redington Model 9200-HTK hand tachometer kit combines low cost with convenience. Simple to use... push the measurement button to record the speed. The tachometer can be used for contact or non-contact measurement on rotating machinery or surface speed. The photoelectric probe is used with reflective tape to detect rotating objects. The accessory adaptor with pointed tip can be added for contact measurement or wheels can be used for surface speed measurement. For measuring in tight or confined spaces, an optional remote sensor is available.

**Features**

- Combination unit - photo and contact
- Wide speed range - 6.0 - 99,999.9 RPM, 0.1 resolution
- Sampling time of 1-10 seconds
- Automatic shutoff after 3 minutes
- Digital display with low battery alarm and reflective light input indicator
- Carrying case included

**Options**

- Remote sensor for measurement in hard to reach places

**Specifications**

<b>Power Source:</b>	4 alkaline batteries (AAA, 1.5 V) continuous measurement 20 hours.	<b>Automatic Power Cutoff:</b>	After 3 minutes from last measurement.
<b>Accuracy:</b>	$\pm 0.01\% \pm 1$ digit RPM f/min. (others $\pm 0.05\%$ or $\pm 1$ digit including tolerance for conversion).	<b>Display:</b>	6 digit LCD
<b>Measurement Distance:</b>	2"-14" (50-300mm) with reflective tape.	<b>Approvals:</b>	CE Compliant, passed EMC tests EMI: EN50081-1 & EMS: EN50082-1
<b>Measurement Range:</b>	6.0 - 99,999.9 RPM	<b>Weight:</b>	7 oz [199g] (with in-line contact adaptor).
<b>Sampling Time:</b>	1.0-10.2 sec.	<b>Operating Temperature:</b>	+41°F to +104°F [+5°C to +40°C]

<b>Models</b>	<b>Description</b>	<b>Models</b>	<b>Description</b>
<b>9200-HTK</b>	Hand Tachometer Kit: includes, Hand Tach. (Photo), In-Contact adaptor, Rubber tips (3), Reflective Tape (10 sheets), Surface Speed wheels, 1 ea. (1/10 m/min., and 1/10 yd./min.), Carrying Case, Batteries (4 AAA size, 1.5 V, Instructions Manual).	<b>9200-HT</b>	Hand Held Tachometer
		<b>1887-021S</b>	Remote Probe
		<b>1895-004S</b>	Rubber Tips
		<b>1895-005S</b>	Surface Wheel (1/10 Meter)
		<b>1895-006S</b>	Surface Wheel (1/10 Yard)
		<b>200507-046S</b>	Reflective Tape (10 Sheets)

\* Items in bold are normally in factory stock.



Dimensions

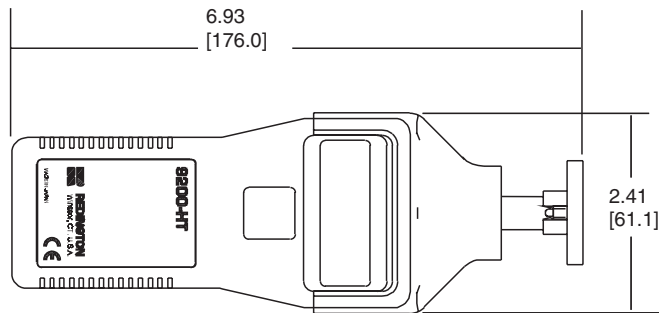
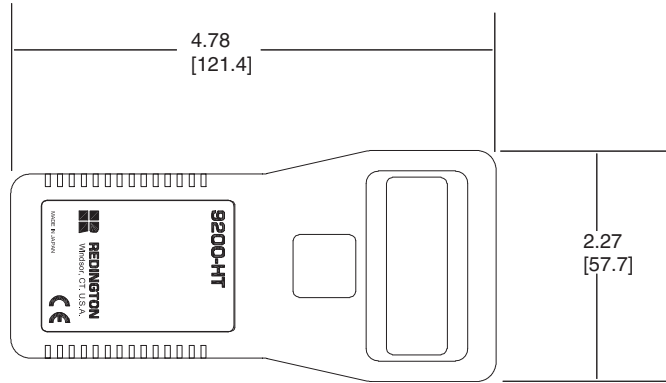

Applications

Speed of many rotating objects

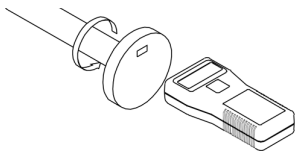

Check motor speeds

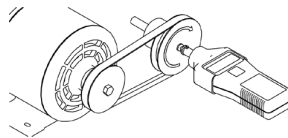

Conveyor line speed

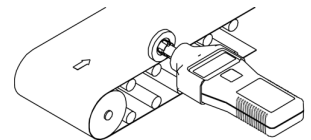



Description

These versatile, dependable and rugged encoders are ideal for use with electronic counters, PLC's, motion controllers and motor drives. A wide selection of resolutions (Pulse Per Revolution, PPR) makes the Model 65 ideal for a wide variety of applications. The sealed aluminum housing offers greater protection from wash down, sprays, dust, moisture, shock and other hazards found in industrial environments.

Features

- Quadrature or unidirectional output
- 3/8" [9.5mm] shaft diameter, 303, stainless steel
- Double shaft extension
- NPN transistor output

Options

- Rugged duty housing
- +5 to +28VDC input power
- Wide selection of resolutions
- Heavy duty sealed bearings
- IP 65 shaft seal

Specifications

<b>Input:</b>	Voltage: +5 to +28VDC Current: 80mA with no output load	<b>Radial Load:</b>	40 pounds maximum
<b>Output:</b>	Current sinking NPN open collector Transistor Single channel, 250mA max quadrature, 250mA max per output.	<b>Axial Shaft Loading:</b>	30 pounds maximum
<b>Connections:</b>	Eurofast connector	<b>Starting Torque:</b>	3.00 oz-inches
<b>Cable /Connector:</b>	(8 pin) RKC 8T2/S618, (Turck P/N) 2 meters long	<b>Moment of Inertia:</b>	6.5 X 10 <sup>6</sup> oz in sec <sup>2</sup>
<b>Housing:</b>	Black non-corrosive finished, aluminum	<b>Mounting:</b>	Tapped mounting holes on three sides for base or face mounting
<b>Max. Shaft Speed:</b>	6,000 RPM	<b>Weight:</b>	1lb ([284g])
<b>Frequency Response:</b>	0-125 kHz	<b>Operating Temp:</b>	32°F to 185°F [0°C to 85°C]
<b>Bearings:</b>	ABEC 3 double sealed shaft ball bearings	<b>Storage Temp:</b>	-13°F to +212°F [-25° to +100°C]
		<b>Shock:</b>	50 g's @ 100ms duration
		<b>Vibration:</b>	10 g's @ 58 to 500 cps
		<b>Humidity:</b>	98% RH non-condensing

Models	Description	PPR*	Models	Description	PPR*
6510-0060		60	6520-0010		10
6510-0100		100	6520-0012	DUAL CHANNEL	12
6510-0600	SINGLE CHANNEL	600	6520-0100	(QUADRATURE)	100
6510-1000		1,000	6520-0120		120
6510-1200		1,200	6520-0500		500
*Only popular PPR's are listed, other PPR's are available on special order.			6520-0600		600
			RKC 8T2/S618	8 Pin Cable 6' (2 meters) long	

Dimensions

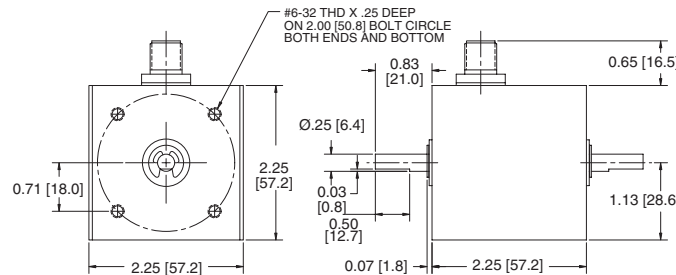

Applications

Measuring Wheel Length sensors

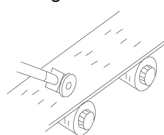

Generating pulses from idler roll with RPG

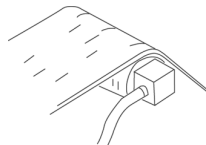

Generating Quadrature signal for position from lead screw rotation using RPG

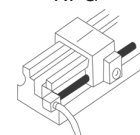

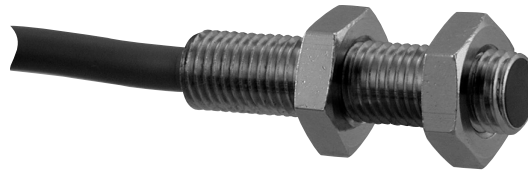

**Description**

The Redington Model 65 proximity switch has an all-metal housing, nickel plated brass, compact size and a long operating distance, 1.5 mm. The Model 65 has a NEMA 6 & 6P, IP67 rating. Its all-metal housing and sealing makes it ideal for most extreme environmental conditions. The Model 65 has built - in protection for short-circuit protection, polarity reversal and power on reset.

**Features**

- Embeddable mounting
- 5,000 Hz switching frequency
- IP 67 rating
- 10-32 VDC operating range
- LED output state indicator
- 8mm diameter

**Models**

**DW-AD-601-M8**

\* Item is normally in factory stock.

**Specifications**

**Supply Voltage:** 10-30VDC  
**Sensing Range:** 0.1" [1.5mm]  
**Sensor Diameter:** 8mm  
**Connection:** PVC cable 6' [2m]  
**Degree of Protection:** IP67  
**Mounting:** Embeddable  
**Max. Switching Frequency:** 5,000 Hz  
**Out-put Status Indicator:** LED  
**Out-put Type:** NPN/N.O. output  
**Built-in Protection:** Short-circuit  
Polarity reversal  
Power-on reset

**Permissible Ripple Content:** ≤ 20%  
**No-load Supply Current:** ≤ 10mA  
**Output Current:** ≤ 200mA  
**Leakage Current at Output:** ≤ 0.1mA  
**Voltage Drop, Switched State:** ≤ 2.0V  
**Ambient Temperature Range:** -13°F to 158°F [-25°C to 70°C]  
**Temperature Drift:** ≤ 10%  
**Hysteresis% Sr:** 1 to 15% (5% typ.)  
**Repeat Accuracy:** (IEC 60947-5-2): ≤ 5% Sr  
**Approvals:** CE Compliant

**Dimensions**

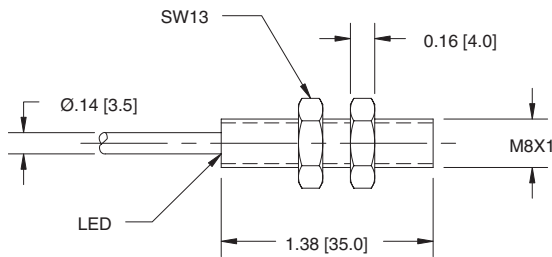

**Wiring Diagram**

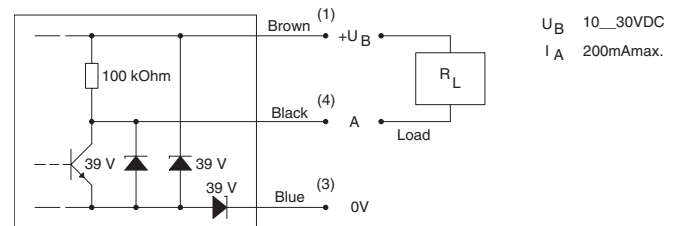

**Applications**

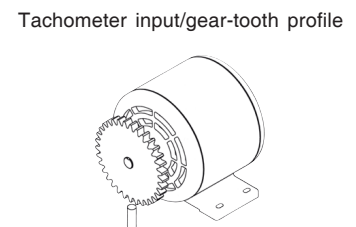
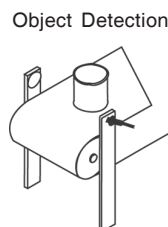
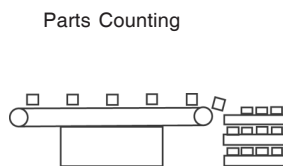



TERM	DEFINITION	
A-B Input	The B input pulses are subtracted from the A input pulses. This type of input is used on counters & indicators.	Directives. For electrical and electronic “finished products”, such as electronic and electromechanical counters, hour meters, these include the Low Voltage Directive and, where relevant, the Electromagnetic Compatibility (EMC) Directive.
A+B Input	The A and B input pulses are added together. This type input is used on counters and position indicators.	Color code The ANSI established color code for the thermocouple wires in the negative lead is always RED. Color code for base metal thermocouples is YELLOW for Type K, BLACK for type J, PURPLE for Type E and BLUE for Type T.
AC	Alternating current; an electric current that reverses its direction at recurring intervals.	
Accuracy	The closeness of an indication or reading of a measurement device to the actual value of the quantity being measured. Usually expressed as a ± percent of full scale output or reading,	Control point The set point at which a system is to be maintained.
Add/Subtract	The ability to count up and down.	CSA (Canadian Standards Association) An independent Canadian testing and standards-making org. similar to Underwriters Laboratories (UL) in the USA. “CSA -certified “ products meet relevant CSA electrical and safety standards.
Ammeter	An instrument used to measure current.	
Analog	A signal that varies continuously in amplitude without interruption.	Current sinking /Open collector In the “off” state the transistor can be viewed as an open switch. When energized it turns “ON”, connecting the output to the ground return lead. The transistor is usually NPN.
Analog Output	A circuit whose output is a reproduction of its input..	
Automatic Reset	A reset that is based on a pre-programmed event. Used in counters or timers.	Current sourcing/Open collector In the “off” state the transistor can be viewed as an open switch. When energized it turns “ON”, connecting the output to the voltage supply lead. The transistor is usually PNP.
Baud Rate	The rate at which each bit is transferred to and from a device.	DC Direct current: An electric current flowing in one direction only and substantially constant in value.
Bidirectional	The counter or encoder can count in both directions.	
Bit	This is the name for a binary digit.	
Byte	A sequence of adjacent binary digits operated on as a single unit. A byte is eight bits in length.	Die A single piece of silicon onto which a semiconductor circuit has been fabricated. (Plural= Dice)
Capacitor	An assembly of one or more pairs of conductors separated by insulators used to store an electrical charge. The capacitance of is measured in FARADS or parts thereof.	Digit A measurement of the display span of a panel meter. By convention, a full digit can assume any value from 0 through 9, a 1/2 digit will display a 1 and overload at 2. For example, the full scale value of a 3 1/2 digit display is 1999.
CE	(Conformite Europeene mark) A symbol (CE) applied to finished products and machinery indicating it meets all applicable European	Digital Volt Meter A device used to measure voltages and give a digital read out.



DIN	A <b>D</b> eutsche <b>I</b> ndustrial <b>N</b> orme standard. Some RCI products utilize these dimensional standards.		sandwich the crystal material. When a voltage is applied molecules in the liquid crystal align themselves with the field generated preventing light from passing, creating a display segment. The pattern on the display forms the required picture or numeral.
Direct drive	Refers to the gear ratio in a mechanical counter one revolution of the input shaft equals 10 counts.		
Drift	A change of a reading or a set point value over long periods due to several factors including change in ambient temperature, time, and line voltage.	LED	(Light Emitting Diode) A diode which emits light of a particular wavelength when a current is passed through it.
EMF	Electromotive force. A rise in (electrical) potential energy. The principle unit is the volt.	LSI	( Large Scale Integration) Used to refer to integrated circuits which today have from thousands to millions of components on one silicon chip.
EMI	Electromagnetic interference.	Load	The electrical demand of a process expressed as power (watts), current (amps), or resistance (ohms).
Encoder	An electromechanical device that translates mechanical motion into electrical pulses.	Maximum operating temperature	The maximum temperature at which an instrument can be operated and still be within operating specifications.
FRAM	Nonvolatile memory. Uses the ferroelectric effect for a storage mechanism.	Micro	A prefix meaning one millionth.
Hertz	(Hz) Units in which the frequency is expressed. Synonymous with cycles per second.	Milli	A prefix meaning one thousandth.
Hysteresis	In an ON-OFF controller it defines the difference between the two switching points. It refers to the difference between the value at which the alarm switches on and the value at which the alarm switches off again.	Multiplication	Any technique used to obtain an output resolution different from the line count.
Incremental encoder	A device that provides a series of periodic signals due to mechanical motion. The number of successive cycles corresponds to the resolvable mechanical increments of motion.	Nano	A prefix meaning one thousand-millionth.
Impedance	The total opposition to electrical flow (resistive plus reactive).	Noise	An unwanted electrical interference on the signal wires.
Input impedance	The resistance of a panel meter as seen from the source. In the case of a voltmeter, this resistance has to be taken into account when the source impedance is high; in the case of an ammeter, when the impedance is low.	OHM	The unit of electrical resistance. A constant voltage of one volt across a resistance of one OHM will produce a current in it of one ampere. OHMS LAW $V=IR$
Joule	The basic unit of thermal energy.	Ohmmeter	An instrument used to measure resistance.
LCD	(Liquid Crystal Display) A liquid crystal display is made of two glass plates, each with a transparent conductive coating, which	Optical Isolator	Sometimes referred to as an optocoupler. A device that isolates two stages of a circuit; e.g., input and output from each other so that interference in one will not effect the other.
		Optical Isolation	A method of reducing noise interference between two circuits using optical isolators.
		Predetermining	The counter can provide an "output" signal at a predetermined count or time.



**Prescaler** Used to convert a pulse input signal to the desired units of indication.

**Quadrature Signals**  
A dual output encoder used for bidirectional motion control. One channel leads the other by 90 degrees.

**RAM** ( Random Access Memory) A memory device which may be accessed at random and which may be written to (altered) or read at any time.

**Range** The values specified by upper and lower limits.

**Rate** Velocity or distance/unit time; can be rotational distance.

**Relays/Electromechanical**  
Relays offer one or more “hard” contacts (metal-to metal) and are switched to the open or closed position by applying voltage to an electromagnetic coil.

**Resistance** The resistance to the flow of electric current measured in ohms. For a conductor, a resistance is a function of diameter, resistivity (an intrinsic) property of the material and length.

**Resistor** A device used primarily for its resistance, which is measured in OHMS. Its primary use is to limit the flow of electrons through a circuit.

**Resolution** The number of increments on an encoder disc. Also, the smallest possible value that an instrument can measure.

**Revolution drive** Refers to the gear ratio in a mechanical counter. One revolution of the input shaft equals 1 count.

**ROM** (Ready Only Memory) A device is programmed with information which should not be lost and which only needs to be read by a computer. Once programmed it cannot be reprogrammed.

**RS 485/422/232** Standards established by the EIA for serial data transmission between two devices.

**RTD** Resistance temperature detector. The resistance changes as a function of temperature.

**Scaling** For direct readout in engineering units, scaling is the capability of the product to associate any desired value to the electrical input range.

**Seebeck effect** This is the basis of thermocouples. When a circuit is formed by a junction of two dissimilar metals and the junctions are held at different temperatures, a current will flow in the circuit caused by the difference in temperature between the two junctions.

**Silicon** The basic element used in the manufacturer of most semiconductor devices.

**Solid-State Relays**  
Use switching elements such as transistors for DC loads and SCR's or FET's for AC loads.

**Stroke Counter** Refers to the input shaft of a mechanical counter. The counter will count when the lever is moved through an arc.

**Thermocouple** The junction of two dissimilar metals which has a voltage output proportional to the difference in temperature between the hot junction and the wires ( cold junction).

Thermocouple type	Type	Material (ANSI Symbol)
	J	Iron/Constantan
	K	Chromel/Alumel
	T	Copper/Constantan
	E	Chromel/Constantan
	R	Platinum/Platinum
		13% Rhodium
	S	Platinum/Platinum
		10% Rhodium
	B	Platinum
		6% Rhodium/Platinum
		/30% Rhodium
	G*	Tungsten Tungsten
		26% Rhenium
	C*	Tungsten
		5% Rhenium/Tungsten
		26% Rhenium
	D*	Tungsten
		3% Rhenium/Tungsten
		/25% Rhenium

\*Not ANSI symbols





Top coming	The input shaft rotates towards you, when viewing the counter from the front.
Top going	The input shaft rotates away from you, when viewing the counter from the front.
Totalizer	A type of counter with no outputs, which is used for accumulating the number of input pulses.
Transistor	From “transfer resistor”, it is a semiconductor device with three electrodes that act as either an amplifier or switch.
Transducer	A device (or medium) that converts energy from one form to another. The term is generally applied to devices that take physical phenomena (pressure, temperature, humidity, flow, etc.) and convert them to electrical signal. Sometimes referred to as “sensor”.
UL	Underwriters Laboratories, Inc. An independent laboratory that establishes safety standards for commercial and industrial products.
Unidirectional	The counter or encoder can only count in one direction.
Volt	The (electrical) potential difference between two points in a circuit. The fundamental unit is derived as work per unit charge- ( $V=W/Q$ ). One volt is the potential difference required to move one coulomb of charge between two points in a circuit using one joule of energy.
X2,X4 Logic	A type of logic that multiplies the signal by a factor of 2 or 4 respectively.

**NEMA STANDARDS**

**NEMA Standards Publication No. 250 guidelines**

NEMA 1	Indoor use- Protects against accidental contact by personnel & falling dirt.
NEMA 2	Indoor use-Protects against falling dirt, liquid, & light splash.
NEMA 3	Outdoor use-Protects against rain, sleet, snow, dirt & dust.
NEMA 3S	Outdoor use- Protects against rain, sleet, snow, dirt, dust & ice buildup.
NEMA 4	In-or-Outdoor-Protects against dirt, dust, hose down, (and heavy splash).

NEMA 4X	In-or Outdoor- Protects against dirt, dust, hose down & corrosion.
NEMA 6	In-or Outdoor- Protects against dirt, dust, hose down & occasional submersion.
NEMA 6P	In-or Outdoor- Protects against dirt, dust, hose down & prolonged submersion.
NEMA 7	Indoor Use- For use in areas of explosive gases or vapors or combustible dust.
NEMA 9	Indoor Use- For use in areas of atmospheres containing combustible dust.
NEMA 12	Indoor Use- Protects against dirt, dust, light splash & oil or coolant spray.
NEMA 13	Indoor Use- Protects against dirt, dust, light splash, & oil or coolant spray.

**The rating system established by IEC Publications 144 and 529 define the following “IP” ratings:**

**1ST CHARACTERISTIC:**

Protection against and penetration of solid bodies.

Numeral	Short Description
0	Non-protected
1	Protected against solid objects greater than 50mm
2	Protected against solid objects greater than 12mm
3	Protected against solid objects greater than 2.5mm
4	Protected against solid objects greater than 1.0mm
5	Dust protected
6	Dust-tight

**2nd CHARACTERISTIC:**

Protection against and penetration of liquids.

Numeral	Short Description
0	Non-protected
1	Protected against dripping water
2	Protected against dripping water when tilted up to 15 degrees
3	Protected against spraying water
4	Protected against splashing water
5	Protected against water jets
6	Protected against heavy seas
7	Protected against the effects of immersion
8	Protected against submersion



<b>1</b>		<b>2</b>		42-1904	34	5330-2200	76
1-1006	19	2-1006	19	43-1904	34	5330-2201	76
1-2015	35	2-1007	20	44-1904	34	5400-0010	15
1-2025	35	2-1016	19	45-1904	34	5400-1010	15
1-2035	35	2-1017	20			55XX	54
1-2045	35	2-1284	28		<b>5</b>	5600	57
1-2215	36	2-2936	39	5-2835	38	5601	57
1-2225	36	2-4016	21	5-4645	42	5602	57
1-2235	36	2-4017	21	5003-001S	13, 50, 76	5610	57
1-2245	36	2-4103	41	5003-002S	8, 46	5611	57
1-2315	36	2-4104	41	5003-003S	8, 46	5612	57
1-2325	36	2-4416	23	5003-004S	8, 46	5620	57
1-2715	37	2-4615	42	5003-005S	8, 46	5621	57
1-2735	37	2-4625	42	5003-007S	72, 74	5622	57
1-2916	39	2-4635	42	5120-0000	48	5630	57
1-2926	39	2-4645	42	5120-0100	48	5631	57
1-2936	39	200507-046S	98	5120-0200	48	5632	57
1-2946	39	200557-001S	85, 88	5120-0310	48	5640	57
1-4103	41	200557-002S	85, 88	5120-1000	48	5641	57
1-4615	42	21-1904	34	5120-1100	48	5642	57
1-4625	42	21-2916	40	5120-1200	48	5650	57
1-4635	42	21-2926	40	5120-2000	48	5651	57
1-4635T	42	21-2936	40	5120-2100	48	5652	57
1-4645	42	21-2946	40	5120-2200	48	5660	57
1-PCU-13	44	22-1904	34	5140-0000	48	5661	57
1-PCU-14	44	22-2936	40	5140-0100	48	5662	57
1-PCU-24	44	23-1904	34	5140-0200	48	5670	57
1-PCU-33	44	24-1904	34	5140-0311	48	5671	57
1-PCU-33T	44	25-1904	34	5140-0312	48	5672	57
1-PCU-34	44			5200-0000	11	5700	60
1-PCU-43	44			5201-0000	11	5701	60
1-PCU-44	44			5202-0000	11	5702	60
10007-009S	42	<b>3</b>		5210-0000	11	5703	60
10007-010S	35	3-1006	19	5211-0000	11	5704	60
10011-001S	42	3-1007	20	5300-0000	13	5705	60
1022-006S	37, 38, 39	3-1804-10	33	5300-0001	13	5706	60
1071-024S	19	3-1804-2	33	5300-0100	13	5707	60
11-0825	30	3-1804-3	33	5300-0101	13	5708	60
11-0845	30	3-1804-4	33	5300-1000	13	5709	60
11-1904	34	3-1804-5	33	5300-1001	13	5710	60
11-2916	40	3-1804-6	33	5300-1010	13	5711	60
11-2936	40	3-1804-7	33	5300-1011	13	5712	60
11B-1415	31	3-1804-8	33	5300-1100	13	5713	60
11B-1425	31	3-1804-9	33	5300-2000	13	5902	62
11B-1435	31	3-2835	38	5300-2001	13	5912	62
11B-1445	31	3-4104	41	5300-2100	13	5922	62
11B-1515	31	31-1904	34	5300-2200	13	5932	62
11B-1525	31	32-1904	34	5300-2201	13	5942	62
11B-1535	31	33-1904	34	5320-0000	50	5952	62
11B-1545	31	3301-0000	8	5320-0001	50	5962	62
11B-1615	31	3301-0010	8	5320-0100	50	5972	62
11B-1625	31	3301-1000	8	5320-0101	50	5982	62
11B-1635	31	3301-2000	8	5320-1000	50	5992	62
11B-1645	31	3301-2010	8	5320-1001	50		
11B-1715	31	3301-3000	8	5320-1010	50	<b>6</b>	
11B-1725	31	3301-3010	8	5320-1011	50	6510-0060	100
11B-1735	31	3302-4322	10	5320-1100	50	6510-0100	100
11B-1745	31	3311-0000	46	5320-2000	50	6510-0600	100
12-1804	33	3311-0010	46	5320-2001	50	6510-1000	100
12-1904	34	3311-1000	46	5320-2100	50	6510-1200	100
1255-004S	39	3311-1010	46	5320-2200	50	6520-0010	100
13-1804	33	3311-2000	46	5320-2201	50	6520-0012	100
13-1904	34	3311-2010	46	5321-0000	50	6520-0100	100
14-1904	34	3311-3000	46	5321-0001	50	6520-0120	100
15-1904	34	3311-3010	46	5322-0000	50	6520-0500	100
1726-044S	93, 97	34-1904	34	5322-0001	50	6520-0600	100
1726-045S	93, 97	35-1904	34	5330-0000	76		
1726-046S	93, 97			5330-0001	76	<b>7</b>	
1887-021S	98	<b>4</b>		5330-1000	76	7-2215	36
1895-004S	98	4-2835	38	5330-1001	76	7-2225	36
1895-005S	98	41-1904	34	5330-2000	76	7-2235	36
1895-006S	98			5330-2001	76		



7-2245	36	732-0001	74	85KSNP	83	P2-1006	19
710-0001	66	732-0002	74	85KSP1	83	P2-1007	20
710-0002	66	732-0003	74	85KSP2	83	P2-1016	19
710-0003	66	732-0004	74	85KSP3	83	P2-1027	20
710-0006	66	750-0002	43	85KSP4	83	P2-1284	28
710-0008	66	750-0007	43	85KSP5	83	P2-3106	29
710-0009	66	750-0016	43	85KSPT	83	P2-4816	24
710-0013	66	750-0114	43	85KSR1	83	P2-4817	24
710-0014	66	750-0156	43	85KSR2	83	P2-4904	26
710-0018	66			85KSRD	83	P2-4906	26
710-0024	66		<b>8</b>	85KSRT	83	P2-7717/60	65
710-0026	66			85KSTK	83	P3-1006	19
710-0032	66	8-1006	19	85KSVA	83	P31-1026	19
710-0051	66	8-1007	20	85KVD	83	P32-1026	19
711-0013	67	8-4416	23	85XX	84	P33-1026	19
711-0014	67	8301	93	8800-0000	88	P38-1026	19
711-0015	67	8301-0110	93	8800-0001	88	P8-1006	19
711-0019	70	8301-1110	93	8800-0010	88	P8-1027	20
711-0020	70	8302	93	8800-0011	88	P8-3206	29
711-0041	70	8302-0010	93	8800-0100	88	P8-4816	24
711-0113	67	8302-0011	93	8800-0101	88	P8-4817	24
711-0114	67	8302-0100	93	8800-0110	88	P8-4904	26
711-0120	67	8302-0101	93	8800-0111	88	P8-4906	26
711-0123	67	8302-1010	93	8810-0000	88	P9-3206	29
711-0124	67	8302-1011	93	8810-0001	88	P9-4904	26
711-0130	67	8302-1100	93	8810-0010	88	P9-4906	26
711-0131	67	8302-1101	93	8810-0011	88	PR2-1284	28
711-0132	67	8303	93	8810-0100	88		
711-0133	67	8303-0100	93	8810-0101	88		<b>R</b>
711-0134	67	8303-0101	93	8810-0110	88	R2-1007	20
711-0138	67	8303-0110	93	8810-0111	88	R2-1017	20
711-0150	69	8303-0111	93			R2-3106	29
711-0152	69	8303-1100	93	<b>9</b>		R2-4016	21
711-0160	69	8303-1101	93			R2-4017	21
711-0161	69	8303-1110	93	9200-HT	98	R2-4416	23
711-0162	69	8303-1111	93	9200-HTK	98	R2-4816	24
711-0163	69	8304	93	9415-001	16	R2-7717/60	65
711-0164	69	8304-0100	93	9415-003	16	R8-3206	29
711-0170	69	8304-0101	93	9415-005	16	R8-4416	23
711-0171	69	8304-1100	93	9425-001	63	R8-4817	24
711-0180	69	8304-1101	93	9425-003	63	R9-4016	21
711-0182	69	8321	97	9425-005	63	R9-4017	21
711-0190	69	8321-0110	97	98WF	30, 40	RKC 8T2/S618	100
711-0191	69	8321-1110	97			RV2-4416	23
711-0192	69	8322	97	<b>B</b>		RV8-4416	23
711-0193	69	8322-0010	97				<b>S</b>
711-0194	69	8322-0011	97	B2-4904	26		
711-0195	69	8322-0100	97	B2-4906	26		
711-0215	67	8322-0101	97	B2-5804	45	SR2-4016	21
711-0216	67	8322-1010	97	B2-5804/E2	45	SR2-4017	21
711-0217	67	8322-1011	97	B2-5806	45	SR2-4816	24
720-0001	71	8322-1100	97	B2-5806/E2	45	SR2-7717/60	65
720-0003	71	8322-1101	97	B8-4904	26	SR8-4816	24
720-0004	71	85KLAD	83	B8-4906	26	SR8-4817	24
720-0007	71	85KLCA	83	B8-5804	45		
720-0008	71	85KLCD	83	B8-5804/E8	45		<b>T</b>
720-0011	71	85KLFQ	83	B8-5806	45	T2-4016	21
720-0012	71	85KLIR	83	B8-5806/E2	45	T2-4017	21
720-0030	71	85KLJT	83				<b>V</b>
720-0031	71	85KLKT	83	<b>D</b>			
720-0036	71	85KLPT	83				
720-5300	64	85KLRT	83	D2-1284	28	V1-2936	39
721-0003	66	85KLTK	83	D2-4904	26	V1-4816	24
721-0004	64, 66, 71	85KLVA	83	D2-4906	26	V2-4416	23
721-0017	66	85KLVD	83	D8-4817	24	V2-4816	24
721-0018	66	85KSAD	83	DW-AD-601M8	101	V2-4817	24
722-0001	72	85KSAN	83			V3-4816	24
722-0002	72	85KSCA	83	<b>E</b>		V8-4016	21
722-0003	72	85KSCD	83			V8-4017	21
722-0004	72	85KSDC	83	E1-1804	17	V8-4416	23
731-0006	67	85KSFQ	83	E2-1804	18	V8-4816	24
731-0040	67	85KSHG	83	E3-1804	18	V8-4817	24
731-0041	67	85KSHR	83			V9-4816	24
731-0042	67	85KSIR	83	<b>P</b>			
731-0046	69	85KSJT	83				
731-0051	67	85KSKT	83	P1-1006	19		



## Custom Capabilities

Redington manufactures a variety of custom products for our customers. These products range from unique items designed for specific applications, to slight variations on our existing models.

If you don't see exactly what you are looking for, give us a call and one of our sales representative can work with you to solve your requirements.



## Contract Electronics, Molding and Assembly



Whether you need electronic design and production, plastic injection molding or product assembly, Redington offers a wide variety of custom capabilities to meet your requirements. With over 43 years experience as a high quality manufacturer, we can help you get your product to market quickly, while maintaining the highest levels of quality.

Contact us today to learn more about how we can help you with your specific needs.



## Стандарт Электрон Связь

Мы молодая и активно развивающаяся компания в области поставок электронных компонентов. Мы поставляем электронные компоненты отечественного и импортного производства напрямую от производителей и с крупнейших складов мира.

Благодаря сотрудничеству с мировыми поставщиками мы осуществляем комплексные и плановые поставки широчайшего спектра электронных компонентов.

Собственная эффективная логистика и склад в обеспечивает надежную поставку продукции в точно указанные сроки по всей России.

Мы осуществляем техническую поддержку нашим клиентам и предпродажную проверку качества продукции. На все поставляемые продукты мы предоставляем гарантию .

Осуществляем поставки продукции под контролем ВП МО РФ на предприятия военно-промышленного комплекса России , а также работаем в рамках 275 ФЗ с открытием отдельных счетов в уполномоченном банке. Система менеджмента качества компании соответствует требованиям ГОСТ ISO 9001.

Минимальные сроки поставки, гибкие цены, неограниченный ассортимент и индивидуальный подход к клиентам являются основой для выстраивания долгосрочного и эффективного сотрудничества с предприятиями радиоэлектронной промышленности, предприятиями ВПК и научно-исследовательскими институтами России.

С нами вы становитесь еще успешнее!

### Наши контакты:

**Телефон:** +7 812 627 14 35

**Электронная почта:** [sales@st-electron.ru](mailto:sales@st-electron.ru)

**Адрес:** 198099, Санкт-Петербург,  
Промышленная ул, дом № 19, литера Н,  
помещение 100-Н Офис 331