

CENTERLINE OF PIN AT TIP
NOT TO VARY FROM CENTERLINE OF
PIN AT DATUM -D- BY MORE THAN
0.20/.008 IN ANY DIRECTION.

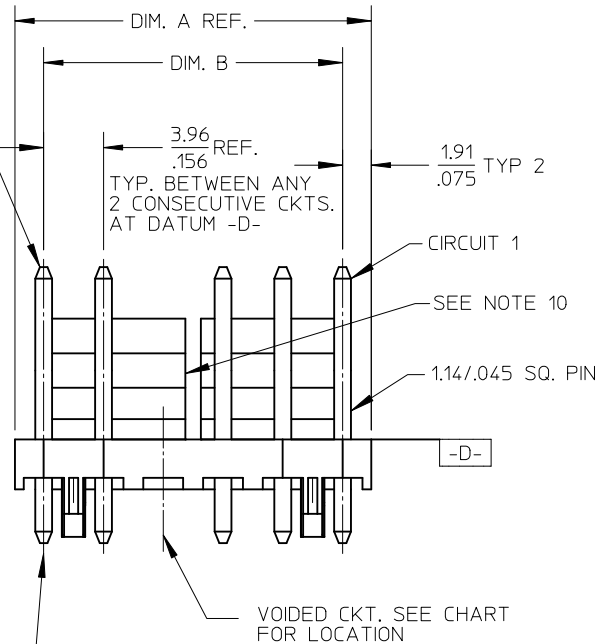

CENTERLINE OF PIN AT TIP
NOT TO VARY FROM CENTERLINE OF
PIN AT DATUM -D- BY MORE THAN
0.13/.005 IN ANY DIRECTION.

SEE PEG DETAIL
SHEET 2

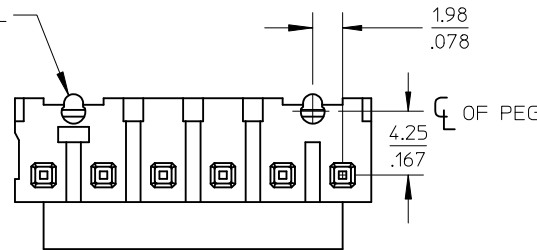

NO. OF CKTS.	DIM. A	DIM. B	SLOT LOC BETWEEN CKTS
2	7.77 .306	3.96±0.05 .156±.002	NONE
3	11.73 .462	7.92±0.08 .312±.003	NONE
4	15.70 .618	11.89±0.08 .468±.003	NONE
5	19.66 .774	15.85±0.10 .624±.004	NONE
6	23.62 .930	19.81±0.10 .780±.004	3 & 4
7	27.58 1.086	23.77±0.10 .936±.004	4 & 5
8	31.55 1.242	27.74±0.13 1.092±.005	4 & 5
9	35.51 1.398	31.70±0.13 1.248±.005	5 & 6
10	39.47 1.554	35.66±0.13 1.404±.005	5 & 6
11	43.43 1.710	39.62±0.15 1.560±.006	6 & 7
12	47.40 1.866	43.59±0.15 1.716±.006	4 & 5 8 & 9

ADD FINISH 197, 241 EC NO: UCP2012-0114 DRWN:MMSTROH 2011/08/09 CHKD:MKIPPER 2011/10/21 APPR:FSM1TH 2011/10/28	QUALITY SYMBOLS	GENERAL TOLERANCES (UNLESS SPECIFIED)	DIMENSION STYLE	SCALE	DESIGN UNITS	THIRD ANGLE PROJECTION
	▽ F = 0 ▽ E = 0 ▽ P = 0	mm INCH	MM/IN	---	INCH	

4 PLACES ± --- ± ---	DRAWN BY	DATE	TITLE
3 PLACES ± --- ± .010	SCHAFFER	12-11-03	
2 PLACES ± 0.25 ± .015	CHECKED BY	DATE	FR. LOCK HEADER ASSEMBLY .156 CENTERS STR SQ PINS W/ PEGS
1 PLACE ± 0.38 ± ---	SAMIEC	12-14-03	
ANGULAR ± 1/2°	APPROVED BY	DATE	MOLEX INCORPORATED
DRAFT WHERE APPLICABLE MUST REMAIN WITHIN DIMENSIONS	MARGULIS	12-18-03	
	MATERIAL NO.	SEE CHART	DOCUMENT NO.
	SIZE	A	SD-42891-001
	THIS DRAWING CONTAINS INFORMATION THAT IS PROPRIETARY TO MOLEX INCORPORATED AND SHOULD NOT BE USED WITHOUT WRITTEN PERMISSION		SHEET NO. 1 OF *

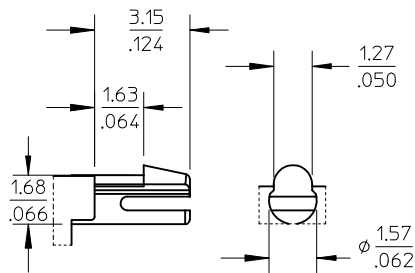

PEG DETAIL

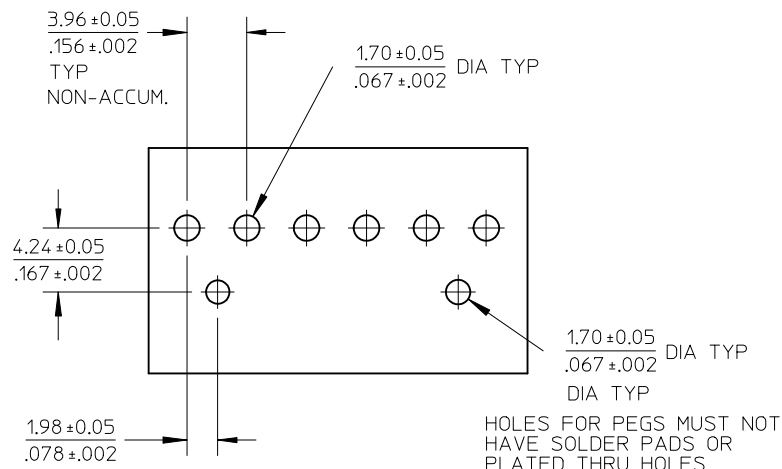

RECOMMENDED PC BOARD HOLE LAYOUT:
COMPONENT SIDE FOR 1.57/.062 THK. PCB

FOR CORRECT ORIENTATION OF PARTS WITH
VOIDS, ELIMINATE CORRESPONDING PCB HOLE.

NOTES:

1. MATERIAL: HEADER-GLASS FILLED POLYESTER, 94V-0, MOLDED NATURAL WHITE PINS: BRASS
2. FINISHES: (197) OVERALL REFLOWED MATTE TIN: 0.00152/.000060 MIN. OVER 0.00127/.000050 MIN. NICKEL OVERALL.
(154) OVERALL TIN: 0.00254/.000100 MIN OVER 0.00127/.000050 MIN NICKEL
(208) SELECT GOLD: 0.00038/.000015 MIN SELECT TIN: 0.00254/.000100 MIN OVERALL NICKEL UNDERPLATE: 0.00127/.000050 MIN
(228) SELECT GOLD: 0.00076/.000030 MIN SELECT TIN: 0.00254/.000100 MIN OVERALL NICKEL UNDERPLATE: 0.00127/.000050 MIN
(241) SELECT GOLD: 0.00051/.000020 MIN. SELECT TIN: 0.00254/.000100 MIN. OVERALL NICKEL UNDERPLATE: 0.00127/.000050 MIN.
3. PRODUCT SPECIFICATION: SEE PS-08-50.
4. PACKAGING INFO: SEE TABLES
5. SOLDERABILITY: PER SMES-152
6. PIN PUSH OUT FORCE: PRIOR TO SOLDERING, A 3 LB MINIMUM FORCE (IN EITHER DIRECTION) SHALL BE REQUIRED TO PUSH THE PIN OUT OF THE HEADER.
7. PARTS ARE STACKABLE END TO END ON 3.96/.156 CENTERS.
8. FOR PART WITHOUT PEGS SEE DWG. NO. SDA-41791.
9. THIS PART CONFORMS TO CLASS B REQUIREMENTS OF COSMETIC SPECIFICATION PS-45499-002.
10. SLOTS ON BACKWALL ARE BETWEEN CIRCUITS. SEE CHART FOR LOCATION.

SEE SHEET 1 EC NO: UCP2012-0114 DRWN:MMSTROH 2011/08/09 CHKD:MKIPPER 2011/10/21 APPR:FSM/TH 2011/10/28	DESCRIPTION QUALITY SYMBOLS $\nabla F = 0$ $\nabla E = 0$ $\nabla P = 0$	GENERAL TOLERANCES (UNLESS SPECIFIED)		DIMENSION STYLE MM/IN		SCALE ---	DESIGN UNITS INCH	THIRD ANGLE PROJECTION	
			mm	INCH	DRAWN BY SCHAFFER	DATE 12-11-03	TITLE FR. LOCK HEADER ASSEMBLY .156 CENTERS STR SQ PINS W/ PEGS		
		4 PLACES	± ---	± ---	CHECKED BY SAMIEC	DATE 12-14-03			
		3 PLACES	± ---	± .010	APPROVED BY MARGULIS	DATE 12-18-03	MOLEX INCORPORATED DOCUMENT NO. SD-42891-001		
2 PLACES	± 0.25	± .015	MATERIAL NO. SEE CHART		SHEET NO. 2 OF *				
1 PLACE	± 0.38	± ---	ANGULAR ± 1/2°		THIS DRAWING CONTAINS INFORMATION THAT IS PROPRIETARY TO MOLEX INCORPORATED AND SHOULD NOT BE USED WITHOUT WRITTEN PERMISSION				
DRAFT WHERE APPLICABLE MUST REMAIN WITHIN DIMENSIONS									

OPTIONS	Group	A-42891-0002/0018	Group	A-42891-0120/0136	Group	A-42891-0137/0153	Group	A-42891-0068/0084
	Header No:	41790-0053/0069	Header No:	41790-0053/0069	Header No:	41790-0053/0069	Header No:	41790-0053/0069
	Pin No:	43294-0214	Pin No:	43294-0209	Pin No:	43294-0210	Pin No:	43294-0301
	Plating:	197	Plating:	208	Plating:	228	Plating:	197
	Pin Length L	18.29/ .720	Pin Length L	18.29/ .720	Pin Length L	18.29/ .720	Pin Length L	20.83/ .820
	Mating M	11.43/ .450	Mating M	11.43/ .450	Mating M	11.43/ .450	Mating M	11.40/ .449
	Gold Loc G	N/A	Gold Loc G	6.86/ .270	Gold Loc G	6.86/ .270	Gold Loc G	N/A
	PC Tail P	3.56/ .140	PC Tail P	3.56/ .140	PC Tail P	3.56/ .140	PC Tail P	6.12/ .241
	Tin Loc T	Overall	Tin Loc T	4.06/ .160	Tin Loc T	4.06/ .160	Tin Loc T	N/A
	Voided Ckts	None	Voided Ckts	None	Voided CKts	None	Voided Ckts	NONE
	Pack Per	PK-42491-001	Pack Per	PK-42491-001	Pack Per	PK-42491-001	Pack Per	PK-42491-002
	Ckts	Material No	Engineer Number	Material No	Engineer Number	Material No	Engineer Number	Material No
2	26-60-6020	A-42891-0002	42891-0120	A-42891-0120	42891-0137	A-42891-0137	26-60-6021	A-42891-0068
3	26-60-6030	A-42891-0003	42891-0121	A-42891-0121	42891-0138	A-42891-0138		A-42891-0069
4	26-60-6040	A-42891-0004	42891-0122	A-42891-0122	42891-0139	A-42891-0139		A-42891-0070
5	26-60-6050	A-42891-0005	42891-0123	A-42891-0123	42891-0140	A-42891-0140		A-42891-0071
6	26-60-6060	A-42891-0006	42891-0124	A-42891-0124	42891-0141	A-42891-0141	26-60-6061	A-42891-0072
7	26-60-6070	A-42891-0007	42891-0125	A-42891-0125	42891-0142	A-42891-0142		A-42891-0073
8	26-60-6080	A-42891-0008	42891-0126	A-42891-0126	42891-0143	A-42891-0143	26-60-6081	A-42891-0074
9	26-60-6090	A-42891-0009	42891-0127	A-42891-0127	42891-0144	A-42891-0144		A-42891-0075
10	26-60-6100	A-42891-0010	42891-0128	A-42891-0128	42891-0145	A-42891-0145	26-60-6101	A-42891-0076
11	26-60-6110	A-42891-0011	42891-0129	A-42891-0129	42891-0146	A-42891-0146		A-42891-0077
12	26-60-6120	A-42891-0012	42891-0130	A-42891-0130	42891-0147	A-42891-0147		A-42891-0078

F	REV:	ECR/ECN INFORMATION	FR. LOCK HEADER ASSEMBLY .156 CENTERS STR SQ PINS W/ PEGS	SHEET No. - 3 -
		EC NO: UCP2012-0114		
		DATE: 10/31/2011		
DOCUMENT NUMBER:		CREATED / REVISED BY:	CHECKED BY:	APPROVED BY:
SD-42891-001		MMSTROH	MKIPPER	FSMITH

OPTIONS	Group	A-42891-0085/0096	Group	A-42891-0097/0112	Group	A-42891-0019/0035	Group	A-42891-0036/0052
	Header No:	41790-0058/0069	Header No:	41790-0054/0069	Header No:	41790-0053/0069	Header No:	41790-0053/0069
	Pin No:	43294-0214	Pin No:	43294-0214	Pin No:	43294-0215	Pin No:	43294-0214
	Plating:	197	Plating:	197	Plating:	241	Plating:	197
	Pin Length L	18.29/ .720	Pin Length L	18.29/ .720	Pin Length L	18.29/ .720	Pin Length L	18.29/ .720
	Mating M	11.43/ .450	Mating M	11.43/ .450	Mating M	11.43/ .450	Mating M	11.43/ .450
	Gold Loc G	N/A	Gold Loc G	N/A	Gold Loc G	6.85/ .270	Gold Loc G	N/A
	PC Tail P	3.56/ .140	PC Tail P	3.56/ .140	PC Tail P	3.56/ .140	PC Tail P	3.56/ .140
	Tin Loc T	OVERALL	Tin Loc T	OVERALL	Tin Loc T	4.06/ .160	Tin Loc T	OVERALL
	Voided Ckts	7	Voided Ckts	3	Voided CKts	NONE	Voided Ckts	2
	Pack Per	PK-42491-001	Pack Per	PK-42491-001	Pack Per	PK-42491-001	Pack Per	PK-42491-001
	Ckts	Material No	Engineer Number	Material No	Engineer Number	Material No	Engineer Number	Material No
2					26-60-6022	A-42891-0019		
3			42891-0097	A-42891-0097	26-60-6032	A-42891-0020	26-62-6030	A-42891-0037
4			42891-0098	A-42891-0098	26-60-6042	A-42891-0021	26-62-6040	A-42891-0038
5			42891-0099	A-42891-0099	26-60-6052	A-42891-0022	26-62-6050	A-42891-0039
6			42891-0100	A-42891-0100	26-60-6062	A-42891-0023	26-62-6060	A-42891-0040
7	42891-0085	A-42891-0085	42891-0101	A-42891-0101	26-60-6072	A-42891-0024	26-62-6070	A-42891-0041
8	42891-0086	A-42891-0086	42891-0102	A-42891-0102	26-60-6082	A-42891-0025	26-62-6080	A-42891-0042
9	42891-0087	A-42891-0087	42891-0103	A-42891-0103	26-60-6092	A-42891-0026	26-62-6090	A-42891-0043
10	26-62-6082	A-42891-0088	42891-0104	A-42891-0104	26-60-6102	A-42891-0027	26-62-6100	A-42891-0044
11	42891-0089	A-42891-0089	42891-0105	A-42891-0105	26-60-6112	A-42891-0028	26-62-6110	A-42891-0045
12	42891-0090	A-42891-0090	42891-0106	A-42891-0106	26-60-6122	A-42891-0029	26-62-6120	A-42891-0046

REV:	ECR/ECN INFORMATION	TITLE:	FR. LOCK HEADER ASSEMBLY .156 CENTERS STR SQ PINS W/ PEGS	SHEET No.
F	EC NO: UCP2012-0114			- 4 -
	DATE: 10/31/2011			
DOCUMENT NUMBER:	CREATED / REVISED BY:	CHECKED BY:	APPROVED BY:	
SD-42891-001	MMSTROH	MKIPPER	FSMITH	

OPTIONS	Group	A-42891-0053/0067	Group	A-42891-0154/0165	Group	A-42891-0166/0180	Group	A-42891-0181/0197
	Header No:	41790-0053/0069	Header No:	41790-0058/0069	Header No:	41790-0055/0069	Header No:	41790-0053/0069
	Pin No:	43294-0214	Pin No:	43294-0214	Pin No:	43294-0214	Pin No:	43294-0213
	Plating:	197	Plating:	197	Plating:	197	Plating:	154
	Pin Length L	18.29/ .720	Pin Length L	18.29/ .720	Pin Length L	18.29/ .720	Pin Length L	18.29/ .720
	Mating M	11.43/ .450	Mating M	11.43/ .450	Mating M	11.43/ .450	Mating M	11.43/ .450
	Gold Loc G	N/A	Gold Loc G	N/A	Gold Loc G	N/A	Gold Loc G	N/A
	PC Tail P	3.56/ .140	PC Tail P	3.56/ .140	PC Tail P	3.56/ .140	PC Tail P	3.56/ .140
	Tin Loc T	OVERALL	Tin Loc T	OVERALL	Tin Loc T	OVERALL	Tin Loc T	OVERALL
	Voided Ckts	4	Voided Ckts	5, 7	Voided CKts	2, 4	Voided Ckts	NONE
	Pack Per	PK-42491-001	Pack Per	PK-42491-001	Pack Per	PK-42491-001	Pack Per	PK-42491-001
	Ckts	Material No	Engineer Number	Material No	Engineer Number	Material No	Engineer Number	Material No
2							50-29-1955	A-42891-0181
3							50-29-1956	A-42891-0182
4		A-42891-0053			42891-0166	A-42891-0166	50-29-1957	A-42891-0183
5	26-62-6051	A-42891-0054			42891-0167	A-42891-0167	50-29-1958	A-42891-0184
6		A-42891-0055			42891-0168	A-42891-0168	50-29-1959	A-42891-0185
7		A-42891-0056	42891-0154	A-42891-0154	42891-0169	A-42891-0169	50-29-1960	A-42891-0186
8		A-42891-0057	42891-0155	A-42891-0155	42891-0170	A-42891-0170	50-29-1961	A-42891-0187
9		A-42891-0058	42891-0156	A-42891-0156	42891-0171	A-42891-0171	50-29-1962	A-42891-0188
10	26-62-6101	A-42891-0059	42891-0157	A-42891-0157	42891-0172	A-42891-0172	50-29-1963	A-42891-0189
11		A-42891-0060	42891-0158	A-42891-0158	42891-0173	A-42891-0173	50-29-1964	A-42891-0190
12		A-42891-0061	42891-0159	A-42891-0159	42891-0174	A-42891-0174	50-29-1965	A-42891-0191

REV:	ECR/ECN INFORMATION	TITLE:	FR. LOCK HEADER ASSEMBLY .156 CENTERS STR SQ PINS W/ PEGS	SHEET No.
F	EC NO: UCP2012-0114			- 5 -
	DATE: 10/31/2011			
DOCUMENT NUMBER:	CREATED / REVISED BY:	CHECKED BY:	APPROVED BY:	
SD-42891-001	MMSTROH	MKIPPER	FSMITH	



Стандарт Электрон Связь

Мы молодая и активно развивающаяся компания в области поставок электронных компонентов. Мы поставляем электронные компоненты отечественного и импортного производства напрямую от производителей и с крупнейших складов мира.

Благодаря сотрудничеству с мировыми поставщиками мы осуществляем комплексные и плановые поставки широчайшего спектра электронных компонентов.

Собственная эффективная логистика и склад в обеспечивает надежную поставку продукции в точно указанные сроки по всей России.

Мы осуществляем техническую поддержку нашим клиентам и предпродажную проверку качества продукции. На все поставляемые продукты мы предоставляем гарантию .

Осуществляем поставки продукции под контролем ВП МО РФ на предприятия военно-промышленного комплекса России , а также работаем в рамках 275 ФЗ с открытием отдельных счетов в уполномоченном банке. Система менеджмента качества компании соответствует требованиям ГОСТ ISO 9001.

Минимальные сроки поставки, гибкие цены, неограниченный ассортимент и индивидуальный подход к клиентам являются основой для выстраивания долгосрочного и эффективного сотрудничества с предприятиями радиоэлектронной промышленности, предприятиями ВПК и научно-исследовательскими институтами России.

С нами вы становитесь еще успешнее!

Наши контакты:

Телефон: +7 812 627 14 35

Электронная почта: sales@st-electron.ru

Адрес: 198099, Санкт-Петербург,
Промышленная ул, дом № 19, литера Н,
помещение 100-Н Офис 331