

General Description

The MAX14970 dual-channel buffer with input equalization and preemphasis is ideal to redrive internal serial-ATA (SATA) 1i, 2i, and 3i signals as well as eSATA 1m and 2m signals. The device features high electrostatic discharge (ESD), $\pm 8\text{kV}$ Human Body Model (HBM) protection. The device can be placed near a SATA connector on the motherboard to overcome board losses and guarantee SATA compliance. The device is SATA specification version 3.0 (gold standard) compliant and can also be pin configured for SATA specification version 2.6 (gold standard) compliance.

The device features hardware SATA-drive cable detection that automatically places the device into a standby mode that consumes less than $20\mu\text{A}$ (typ) standby current when no drive is connected. In addition, the device features an independent channel dynamic power-down mode where power consumption is reduced when no input signal is present. The device maintains output common-mode levels to meet internal SATA version 3.0 standards and prevent delays when coming out of low-power mode.

The device preserves signal integrity at the receiver by reestablishing full output levels and reducing the total system jitter (T_j) by providing equalization. The device features channel-independent digital preemphasis controls to drive SATA outputs over longer trace lengths to meet internal SATA specifications. SATA out-of-band (OOB) signaling is supported using high-speed out-of-band signal detection on the inputs, and squelch on the corresponding outputs. Inputs and outputs are all internally 50Ω terminated and must be AC-coupled to the SATA controller IC and SATA device.

The device operates from a single $+3.3\text{V}$ (typ) supply, is available in a small, $4\text{mm} \times 4\text{mm}$ TQFN package with flow-through traces for ease of layout, and is specified over the extended -40°C to $+85^\circ\text{C}$ operating temperature range.

Benefits and Features

- Robust Solution for Harsh Environments
 - Extended Temp Rating: -40°C to $+85^\circ\text{C}$
 - High ESD Protection on All Pins: $\pm 8\text{kV}$ (HBM)
 - TQFN ($4\text{mm} \times 4\text{mm}$) Package for Resistance to Vibration/Shocks
- Unique Power-Saving Design
 - Standby State: $<1\text{mW}$ (typ)
 - Dynamic Power-Down State
 - Idle State: 52.8mW (typ)
 - Active State: 231mW (typ)
- Design Flexibility
 - Input Equalization and Selectable Output Preemphasis
 - Single 3.3V Supply Operation
 - SATA 3i (6.0Gbps), SATA 2i/2m (3.0Gbps), and SATA 1i/1m (1.5Gbps) Compatible

Applications

- Industrial/Embedded PC
- Portable IPC/HMI
- Industrial Server
- Medical
- SATA SSDs or HDDs

Ordering Information appears at end of data sheet.

For related parts and recommended products to use with this part, refer to: www.maximintegrated.com/MAX14970.related

Absolute Maximum Ratings

(All voltages referenced to GND, unless otherwise noted.)

V _{CC}	-0.3V to +4.0V
AINP, AINM, BINP, BINM, EN, $\overline{\text{CAD}}$, MODE, PA, PB (Note 1)	-0.3V to (V _{CC} + 0.3V)
Short-Circuit Output Current AOUTP, AOUTM, BOUTP, BOUTM.....	±30mA
Continuous Current at Inputs AINP, AINM, BINP, BINM.....	±5mA

Continuous Power Dissipation (T_A = +70°C)

TQFN (derate 25.6mW/°C above +70°C).....	2051mW
Operating Temperature Range.....	-40°C to +85°C
Storage Temperature Range.....	-55°C to +150°C
Lead Temperature (soldering, 10s).....	+300°C
Soldering Temperature (reflow).....	+260°C

Note 1: All I/O pins are clamped by internal diodes.

Stresses beyond those listed under "Absolute Maximum Ratings" may cause permanent damage to the device. These are stress ratings only, and functional operation of the device at these or any other conditions beyond those indicated in the operational sections of the specifications is not implied. Exposure to absolute maximum rating conditions for extended periods may affect device reliability.

Package Thermal Characteristics (Note 2)

TQFN

Junction-to-Ambient Thermal Resistance (θ _{JA})	39°C/W
Junction-to-Case Thermal Resistance (θ _{JC}).....	6°C/W

Note 2: Package thermal resistances were obtained using the method described in JEDEC specification JESD51-7, using a four-layer board. For detailed information on package thermal considerations, refer to www.maximintegrated.com/thermal-tutorial.

Electrical Characteristics

(V_{CC} = +3.0V to +3.6V, C_{CL} = 10nF coupling capacitor on each output, R_L = 50Ω, T_A = -40°C to +85°C, unless otherwise noted. Typical values are at V_{CC} = +3.3V, T_A = +25°C.) (Note 3)

PARAMETER	SYMBOL	CONDITIONS	MIN	TYP	MAX	UNITS
Operating Power-Supply Range	V _{CC}		3.0		3.6	V
Operating Supply Current	I _{CC}	PA = PB = V _{CC} , D10.2 pattern, f = 3GHz, active state		70	100	mA
		PA = PB = GND, D10.2 pattern, f = 3GHz, active state		60	85	
Standby Supply Current	I _{STBY}	EN = GND or $\overline{\text{CAD}}$ = V _{CC}		20	500	μA
Dynamic Power-Down Current	I _{DYNPD}			16	20	mA
Differential Input Resistance	Z _{RX-DIFF-DC}	(Note 4)	85	100	115	Ω
Differential Output Resistance	Z _{TX-DIFF-DC}	(Note 4)	85	100	115	Ω
AC PERFORMANCE						
Differential Input Return Loss (Notes 4, 5)	RL _{RX-DIFF}	150MHz ≤ f < 300MHz		18		dB
		300MHz ≤ f < 600MHz		14		
		600MHz ≤ f < 1200MHz		10		
		1.2GHz ≤ f < 2.4GHz		8		
		2.4GHz ≤ f ≤ 3.0GHz		3		

Electrical Characteristics (continued)

($V_{CC} = +3.0V$ to $+3.6V$, $C_{CL} = 10nF$ coupling capacitor on each output, $R_L = 50\Omega$, $T_A = -40^\circ C$ to $+85^\circ C$, unless otherwise noted. Typical values are at $V_{CC} = +3.3V$, $T_A = +25^\circ C$.) (Note 3)

PARAMETER	SYMBOL	CONDITIONS	MIN	TYP	MAX	UNITS
Common-Mode Input Return Loss (Notes 4, 5)	RL_{RX-CM}	$150MHz \leq f < 300MHz$	5			dB
		$300MHz \leq f < 600MHz$	5			
		$600MHz \leq f < 1200MHz$	2			
		$1.2GHz \leq f < 2.4GHz$	2			
		$2.4GHz \leq f \leq 3.0GHz$	2			
Differential Output Return Loss (Notes 4, 5)	$RL_{TX-DIFF}$	$150MHz \leq f < 300MHz$	14			dB
		$300MHz \leq f < 600MHz$	8			
		$600MHz \leq f < 1200MHz$	6			
		$1.2GHz \leq f < 2.4GHz$	6			
		$2.4GHz \leq f \leq 3.0GHz$	3			
Common-Mode Output Return Loss (Notes 4, 5)	RL_{TX-CM}	$150MHz \leq f < 300MHz$	8			dB
		$300MHz \leq f < 600MHz$	5			
		$600MHz \leq f < 1200MHz$	2			
		$1.2GHz \leq f < 2.4GHz$	2			
		$2.4GHz \leq f \leq 3.0GHz$	1			
Differential Input Signal Range	$V_{RX-DIFF-PP}$	SATA 2i, SATA 3i, MODE = GND (Note 4)	240		1000	mV_{P-P}
		SATA 2i, SATA 3i, MODE = V_{CC} (Note 6)	220		1000	
Differential Output Swing	$V_{TX-DIFF-PP}$	$f = 750MHz$, $f = 3.0GHz$, PA = PB = GND (Notes 4, 6)	400		700	mV_{P-P}
Output Preemphasis	$V_{TX-DIFF-PP-PE}$	$f = 750MHz$, PA = PB = V_{CC}		3		dB
Input Equalization	$V_{RX-DIFF-PP-EQ}$	$V_{RX-DIFF-PP} = 300mV_{P-P}$		2.7		dB
Preemphasis Time Period	t_{PE}	$f = 750MHz$, PA = PB = V_{CC}		150		ps
Propagation Delay	t_{PD}			240		ps
Output Rise/Fall Time	$t_{TX-RISE-FALL}$	PA = PB = GND, $C_L = 0.5pF$ (Notes 5, 7)	40			ps
Deterministic Jitter (Notes 5, 8)	$t_{TX-DJ-DD}$	Data rate = 3.0Gbps, PA = PB = GND			17	ps_{P-P}
		Data rate = 6.0Gbps, PA = PB = GND			20	
Random Jitter	$t_{TX-RJ-DD}$	PA = PB = GND (Notes 5, 8)			1.5	ps_{RMS}
OOB Detector Threshold	V_{OOB_TH}	SATA OOB pattern, MODE = GND (Note 4)	75		200	mV_{P-P}
		SATA OOB pattern, MODE = V_{CC} (Note 6)	50		150	
OOB Output Enter/Exit Time	t_{OOB}	(Notes 5, 9)		3	5	ns
OOB Differential Offset Delta	$\Delta V_{OOB-DIFF}$	(Note 10)	-100		+100	mV

Electrical Characteristics (continued)

($V_{CC} = +3.0V$ to $+3.6V$, $C_{CL} = 10nF$ coupling capacitor on each output, $R_L = 50\Omega$, $T_A = -40^\circ C$ to $+85^\circ C$, unless otherwise noted. Typical values are at $V_{CC} = +3.3V$, $T_A = +25^\circ C$.) (Note 3)

PARAMETER	SYMBOL	CONDITIONS	MIN	TYP	MAX	UNITS
OOB Common-Mode Delta	ΔV_{OOB-CM}	(Note 10)	-50		+50	mV
OOB Output Disable	$V_{OOB-OUT}$	$V_{IN} < V_{CCB}$ (min), output voltage in squelch (Note 5)			30	mV _{P-P}
Dynamic Power-Down Exit Time	t_{DPD}	SATA OOB pattern (Note 5)			20	ns
Output Common-Mode Delta	ΔV_{OUT-CM}	(Note 11)	-25		+25	mV
LOGIC INPUT						
Input Logic-High	V_{IH}	EN, \overline{CAD} , PA, PB, MODE	1.4			V
Input Logic-Low	V_{IL}	EN, \overline{CAD} , PA, PB, MODE			0.6	V
Input Logic Hysteresis	V_{HYST}	EN, \overline{CAD} , PA, PB, MODE		0.1		V
Input Pullup/Pulldown Resistance	R_{PU-PD}			370		k Ω
ESD PROTECTION						
All Pins		Human Body Model		± 8		kV

Note 3: All devices are 100% production tested at $T_A = +85^\circ C$. Specifications over the operating temperature range are guaranteed by design.

Note 4: This specification meets SATA version 3.0 (gold standard).

Note 5: Guaranteed by design.

Note 6: This specification meets SATA version 2.6 (gold standard).

Note 7: Rise and fall times are measured using 20% and 80% levels.

Note 8: DJ measured using K28.5 pattern; RJ measured using D10.2 pattern.

Note 9: Total time for OOB detection circuit to enable/squelch the output.

Note 10: Difference between squelched and not squelched in the active mode.

Note 11: Difference between output common mode in the active and dynamic power-down state.

Typical Operating Characteristics

(V_{CC} = +3.3V, T_A = +25°C, all eye diagrams measured using K28.5 pattern, unless otherwise noted.)

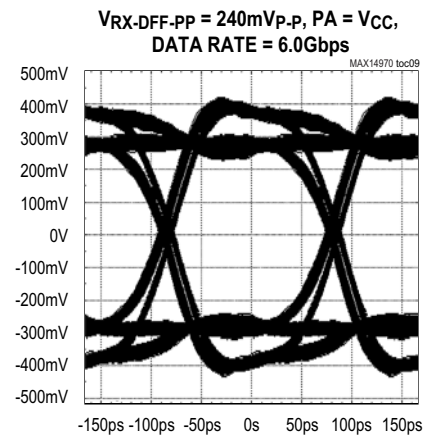
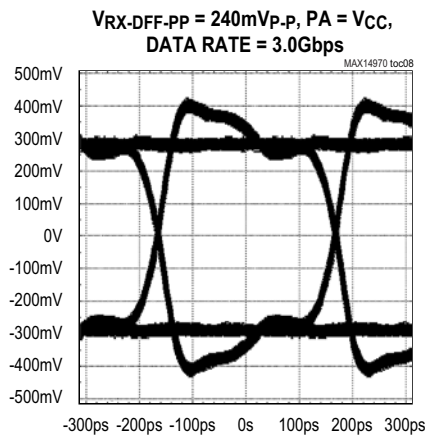
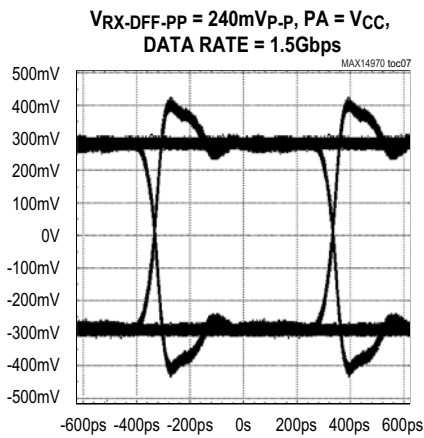
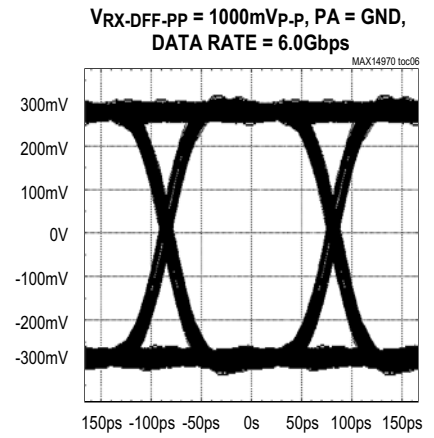
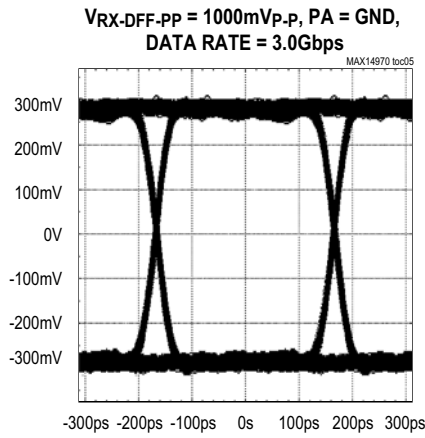
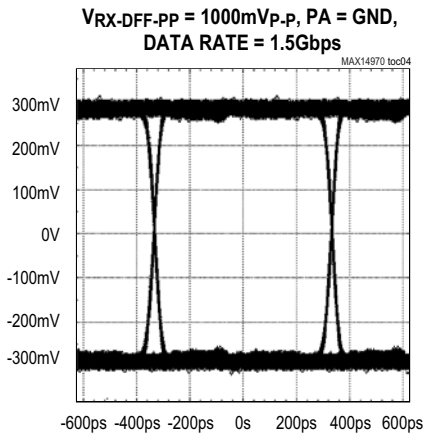
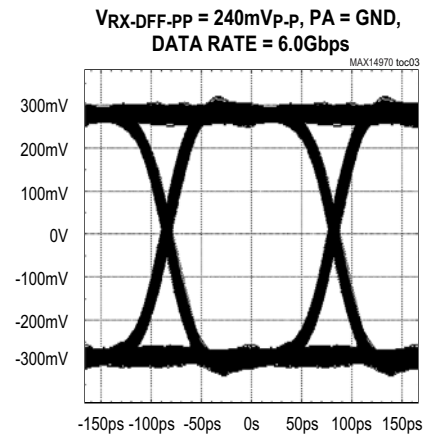
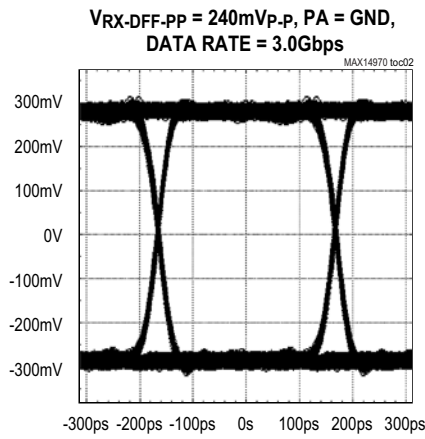
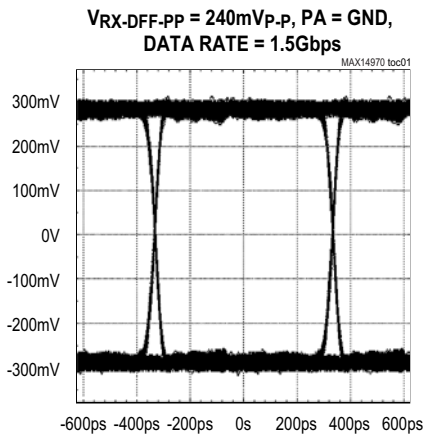

Typical Operating Characteristics (continued)

(V_{CC} = +3.3V, T_A = +25°C, all eye diagrams measured using K28.5 pattern, unless otherwise noted.)

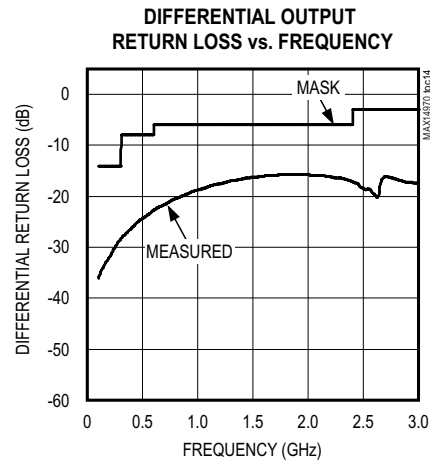
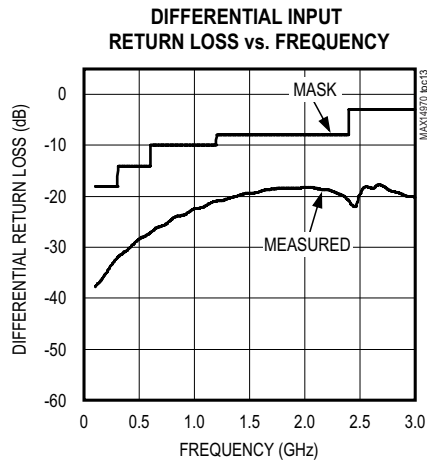
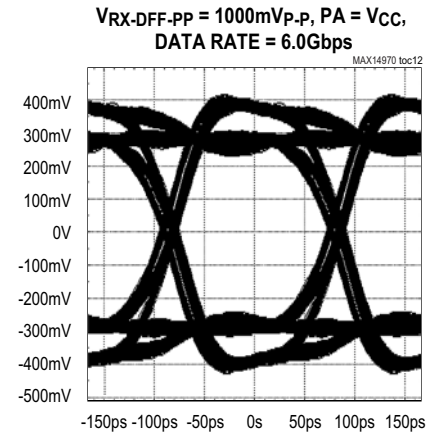
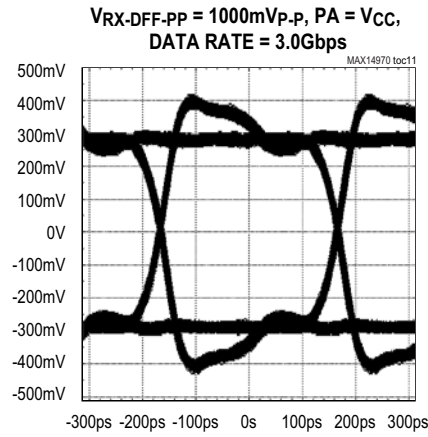
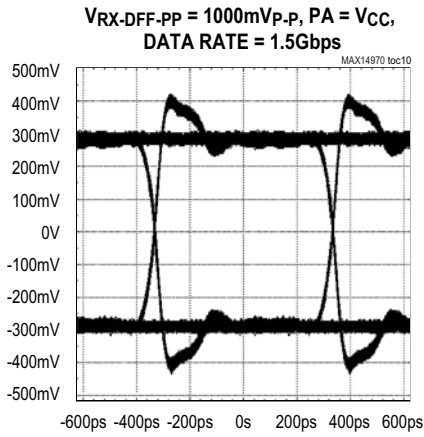

Pin Configuration

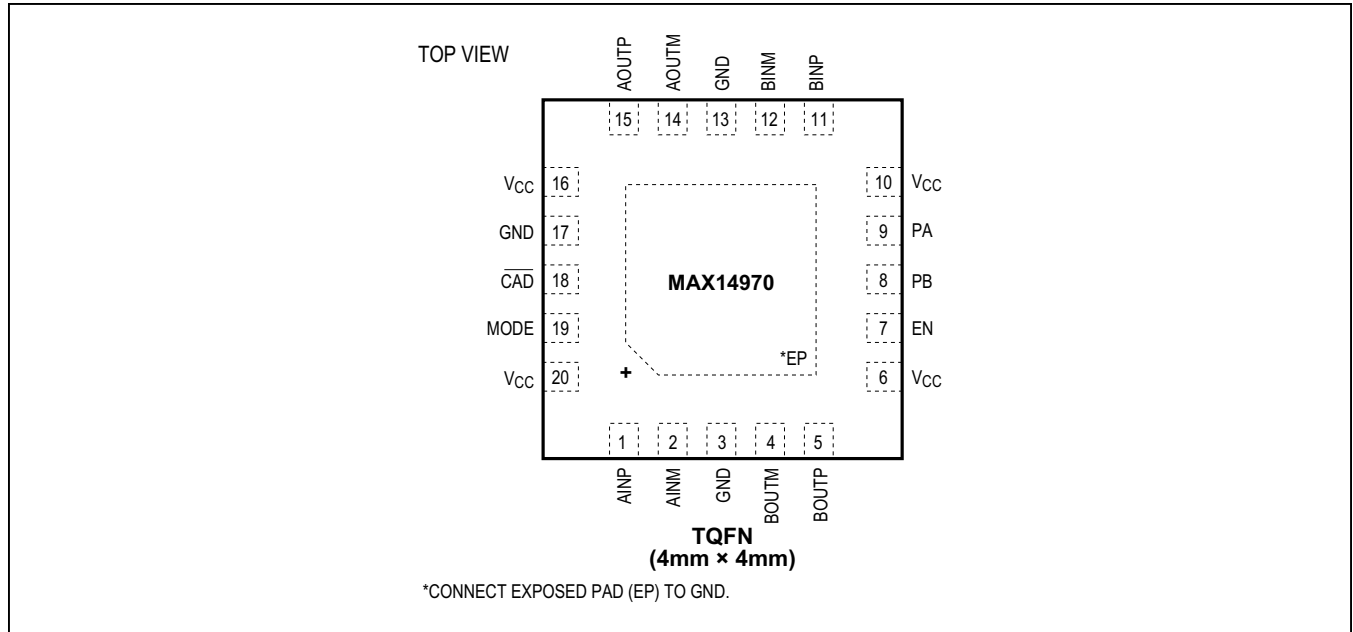

Pin Description

PIN	NAME	FUNCTION
1	AINP	Noninverting Input, Channel A
2	AINM	Inverting Input, Channel A
3, 13, 17	GND	Ground
4	BOUTM	Inverting Output, Channel B
5	BOUTP	Noninverting Output, Channel B
6, 10, 16, 20	V _{CC}	Positive Supply Voltage Input. Bypass V _{CC} to GND with 1μF and 0.01μF capacitors in parallel as close as possible to the device.
7	EN	Active-High Enable Input. Drive EN low to put the device in standby mode. Drive EN high for normal operation. EN has a 390kΩ (typ) pulldown resistor.
8	PB	Channel B Preemphasis-Enable Input. Drive PB high to enable channel B output preemphasis. Drive PB low for standard SATA output level. PB has a 390kΩ (typ) pulldown resistor.

PIN	NAME	FUNCTION
9	PA	Channel A Preemphasis-Enable Input. Drive PA high to enable channel A output preemphasis. Drive PA low for standard SATA output level. PA has a 390kΩ (typ) pulldown resistor.
11	BINP	Noninverting Input, Channel B
12	BINM	Inverting Input, Channel B
14	AOUTM	Inverting Output, Channel A
15	AOUTP	Noninverting Output, Channel A
18	CAD	Active-Low Cable-Detect Input. For external SATA applications, drive CAD high to put the device in standby mode. Drive CAD low for normal operation. CAD has a 390kΩ (typ) pullup resistor. For internal SATA applications, connect CAD to ground.
19	MODE	OOB Threshold Level Set. MODE has a 390kΩ (typ) pulldown resistor.
—	EP	Exposed Pad. Internally connected to GND. EP must be electrically connected to a ground plane for proper thermal and electrical operation.

Functional Diagram/Truth Table

MODE	VOOB_TH_LOW (mVp-p)	VOOB_TH_HIGH (mVp-p)
0	75	200
1	50	150

EN	PA	PB	CHANNEL A	CHANNEL B
0	X	X	STANDBY	STANDBY
1	0	0	STANDARD SATA	STANDARD SATA
1	1	0	PREEMPHASIS	STANDARD SATA
1	0	1	STANDARD SATA	PREEMPHASIS
1	1	1	PREEMPHASIS	PREEMPHASIS

EN	CAD	STATUS
0	0	LOW-POWER STANDBY
0	1	LOW-POWER STANDBY
1	0	ACTIVE
1	1	LOW-POWER STANDBY

NOTE: PA, PB, EN, AND MODE HAVE A 390kΩ RESISTOR PULLDOWN TO GND. CAD HAS A 390kΩ RESISTOR PULLUP TO V_{CC}. X = DON'T CARE.

Detailed Description

The MAX14970 consists of two identical buffers that take SATA input signals and return them to full SATA compliant output levels. Each buffer includes an equalizer, a limiting amplifier, and an output driver with preemphasis. The buffer outputs are protected from high-voltage electrostatic discharge (ESD) to ±8kV Human Body Model (HBM).

Input/Output Terminations

Inputs and outputs are internally 50Ω terminated and must be AC-coupled to the SATA controller IC and SATA device for proper operation.

OOB Signal Detection

The device provides full OOB signal support through high-speed, OOB-detection circuitry. SATA OOB differential input signals of V_{OOB_TH_LOW} or less are detected as off and are not passed to the output. This prevents the system from responding to unwanted noise. SATA OOB

differential input signals of V_{OOB_TH_HIGH} or more are detected as on and passed to the output. This allows OOB signals to transmit through the device. The time for the OOB detection circuit to detect an inactive SATA OOB input and squelch the associated output, or detect an active SATA OOB input and enable the output, is 3ns (typ). The MODE pin can be used to program the OOB detection range. When MODE = GND, the SATA version 3.0 range is used. When MODE = V_{CC}, the SATA version 2.6 range is used.

Enable Input

The device features an active-high enable input (EN). EN has an internal pulldown resistor of 390kΩ (typ). Drive EN low or leave unconnected to place the device into low-power standby mode. In standby, the buffers are disabled, reducing the supply current to 20μA (typ). Drive EN high for normal operation.

Cable-Detect Input

The device features an active-low, cable-detect input ($\overline{\text{CAD}}$) for use in external SATA applications. $\overline{\text{CAD}}$ has an internal 390k Ω (typ) pullup resistor. Drive $\overline{\text{CAD}}$ high or leave unconnected to place the device into low-power standby mode. In this mode, the buffers are disabled, reducing supply current to 20 μA (typ). This signal is normally driven low by attaching a SATA cable into a properly wired socket (see [Figure 4](#)). If the cable-detect feature is not desired, connect $\overline{\text{CAD}}$ to GND.

Dynamic Power-Down Mode

The device features a dynamic power-down mode where the device shuts down the major power-consuming circuitry. The device detects if the input signal is not present for a 4 μs (typ) duration. Normal operation resumes after 20ns (max) when a signal above the OOB threshold level is detected at the input. This function is implemented separately for both channels. The output common mode remains virtually unchanged when entering or exiting

dynamic power-down mode, making the device ideal for internal SATA applications.

Output Preemphasis Selection Inputs

The device has two preemphasis control-logic inputs, PA and PB. PA and PB have internal 390k Ω (typ) pulldown resistors. PA and PB enable preemphasis to the outputs of their corresponding buffers (see the [Functional Diagram/Truth Table](#)). Drive PA or PB low or leave unconnected for standard SATA output levels. Drive PA or PB high to provide preemphasis to the output. The preemphasis output signal compensates for attenuation from longer trace lengths or to meet internal SATA specifications.

Applications Information

[Figure 1](#) shows a typical application circuit with the MAX14970 used to drive an internal SATA SDD or HDD. [Figure 4](#) shows a typical application circuit with the MAX14970 used to drive an external SATA SSD or HDD.

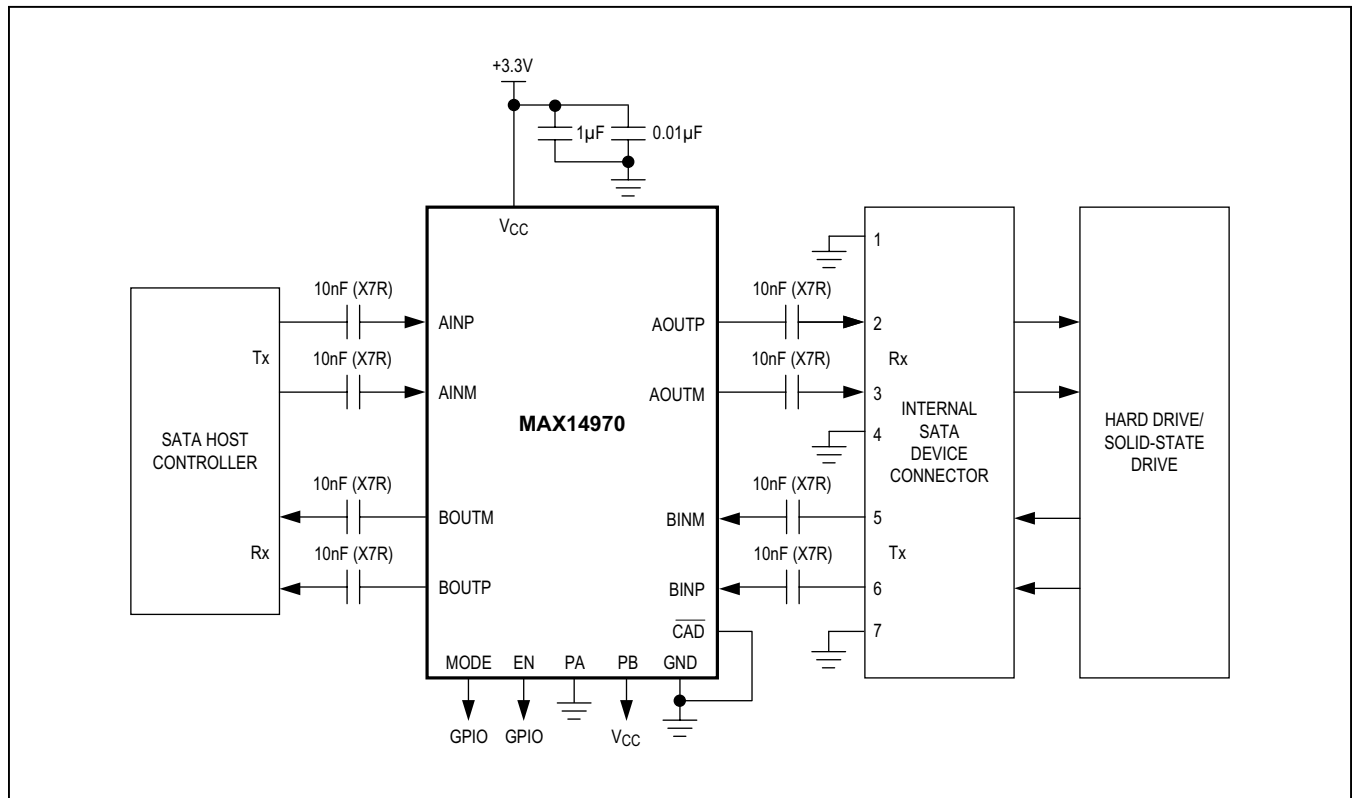

Figure 1. Typical Application Circuit for Internal SATA Applications

Exposed-Pad Package

The exposed-pad, 20-pin TQFN package incorporates features that provide a very low-thermal resistance path for heat removal from the device. The exposed pad on the device must be soldered to GND for proper thermal and electrical performance. For more information on exposed-pad packages, refer to [Application Note 862: HFAN-08.1: Thermal Considerations of QFN and Other Exposed-Paddle Packages](#).

Layout

Use controlled-impedance transmission lines to interface with the device’s high-speed inputs and outputs. Place power-supply decoupling capacitors as close as possible to the V_{CC} pin.

Power-Supply Sequencing

Caution: Do not exceed the absolute maximum ratings because stresses beyond the listed ratings can cause permanent damage to the device.

Proper power-supply sequencing is recommended for all devices. Always apply V_{CC} before applying signals, especially if the signal is not current limited.

ESD Protection

As with all Maxim Integrated devices, ESD protection structures are incorporated on all pins to protect against electrostatic discharges encountered during handling and assembly. The MAX14970 is protected against ESD events up to ±8kV (HBM). The ESD structures withstand ±8kV in all states: normal operation and powered down. After an ESD event, the device continues to function without latchup.

HBM

The device is rated for ±8kV ESD protection using the HBM (MIL-STD-883, Method 3015). [Figure 2](#) shows the HBM voltage, and [Figure 3](#) shows the current waveform it generates when discharged into a low-impedance state. This model consists of a 100pF capacitor charged to the ESD voltage of interest that is then discharged into the device through a 1.5kΩ resistor.

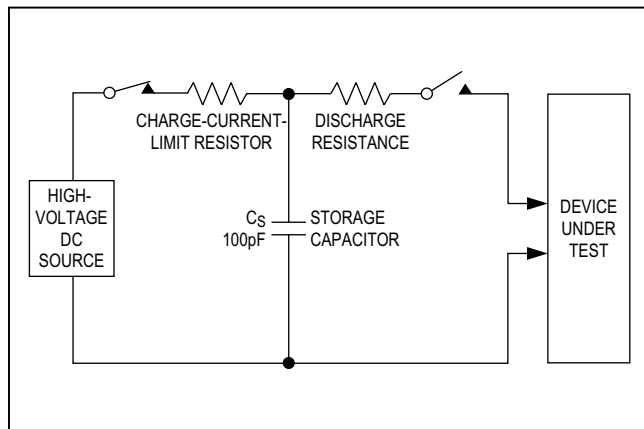

Figure 2. Human Body ESD Test Model

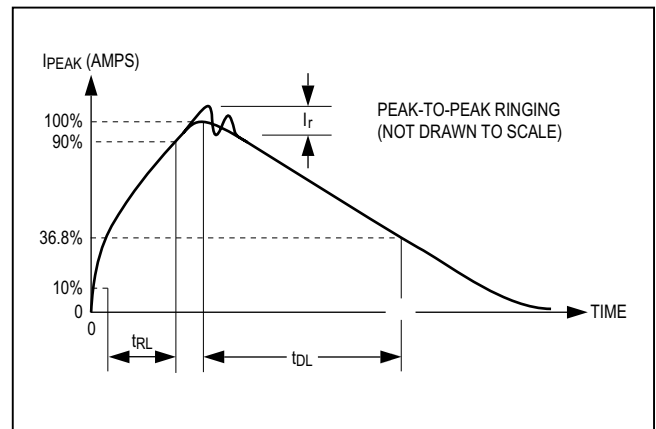

Figure 3. Human Body Current Waveform

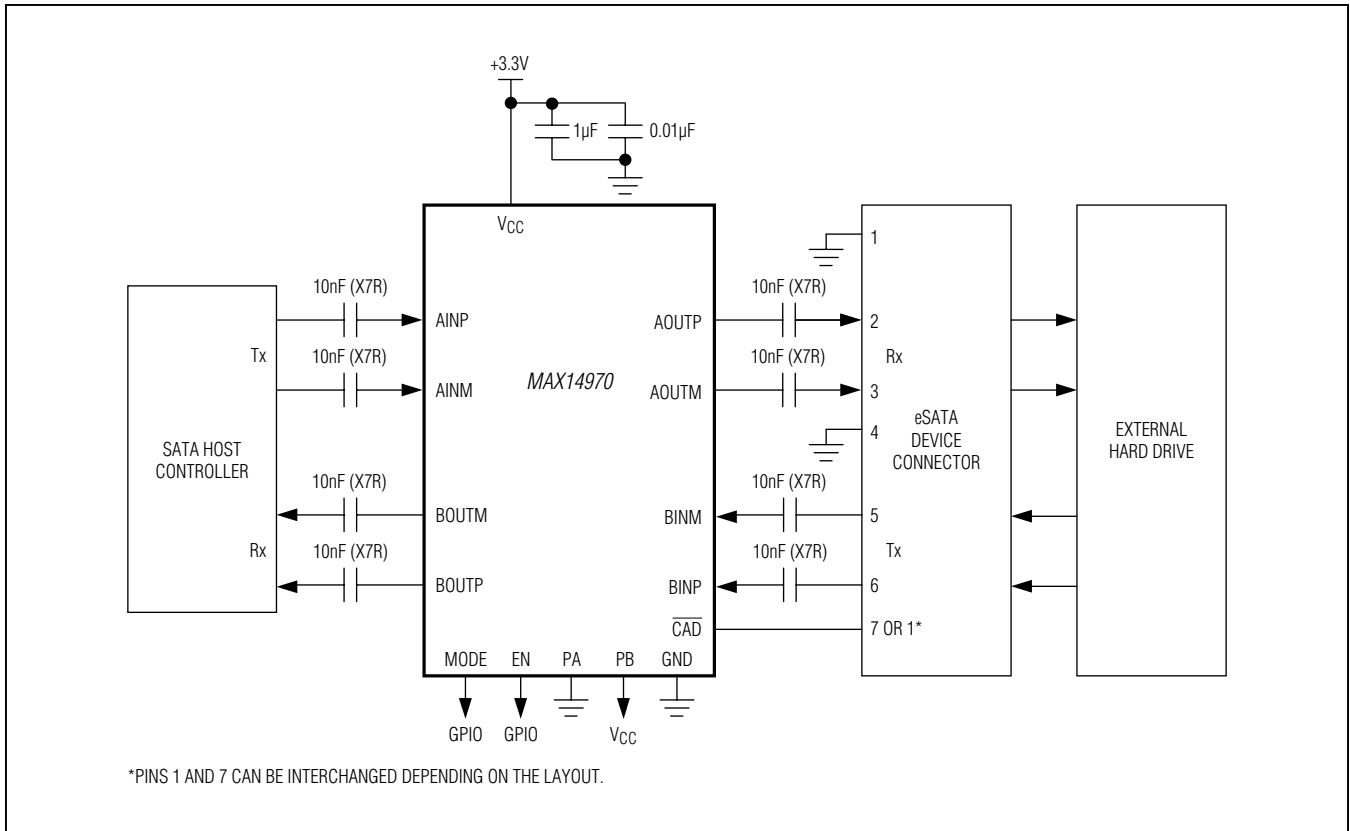

Figure 4. Typical Application Circuit for External SATA Application

Ordering Information

PART	TEMP RANGE	PIN-PACKAGE
MAX14970ETP+	-40°C to +85°C	20 TQFN-EP*

+Denotes a lead(Pb)-free/RoHS-compliant package.
 *EP = Exposed pad.

Chip Information

PROCESS: BICMOS

Package Information

For the latest package outline information and land patterns (footprints), go to www.maximintegrated.com/packages. Note that a "+", "#", or "-" in the package code indicates RoHS status only. Package drawings may show a different suffix character, but the drawing pertains to the package regardless of RoHS status.

PACKAGE TYPE	PACKAGE CODE	OUTLINE NO.	LAND PATTERN NO.
20 TQFN-EP	T2044+2	21-0139	90-0036

MAX14970

Ruggedized 6Gbps SATA Redriver with High ESD
and Extended Temperature Operation

Revision History

REVISION NUMBER	REVISION DATE	DESCRIPTION	PAGES CHANGED
0	3/13	Initial release	—

For pricing, delivery, and ordering information, please contact Maxim Direct at 1-888-629-4642, or visit Maxim Integrated's website at www.maximintegrated.com.

Maxim Integrated cannot assume responsibility for use of any circuitry other than circuitry entirely embodied in a Maxim Integrated product. No circuit patent licenses are implied. Maxim Integrated reserves the right to change the circuitry and specifications without notice at any time. The parametric values (min and max limits) shown in the Electrical Characteristics table are guaranteed. Other parametric values quoted in this data sheet are provided for guidance.



**Стандарт
Электрон
Связь**

Мы молодая и активно развивающаяся компания в области поставок электронных компонентов. Мы поставляем электронные компоненты отечественного и импортного производства напрямую от производителей и с крупнейших складов мира.

Благодаря сотрудничеству с мировыми поставщиками мы осуществляем комплексные и плановые поставки широчайшего спектра электронных компонентов.

Собственная эффективная логистика и склад в обеспечивает надежную поставку продукции в точно указанные сроки по всей России.

Мы осуществляем техническую поддержку нашим клиентам и предпродажную проверку качества продукции. На все поставляемые продукты мы предоставляем гарантию .

Осуществляем поставки продукции под контролем ВП МО РФ на предприятия военно-промышленного комплекса России , а также работаем в рамках 275 ФЗ с открытием отдельных счетов в уполномоченном банке. Система менеджмента качества компании соответствует требованиям ГОСТ ISO 9001.

Минимальные сроки поставки, гибкие цены, неограниченный ассортимент и индивидуальный подход к клиентам являются основой для выстраивания долгосрочного и эффективного сотрудничества с предприятиями радиоэлектронной промышленности, предприятиями ВПК и научно-исследовательскими институтами России.

С нами вы становитесь еще успешнее!

Наши контакты:

Телефон: +7 812 627 14 35

Электронная почта: sales@st-electron.ru

Адрес: 198099, Санкт-Петербург,
Промышленная ул, дом № 19, литера Н,
помещение 100-Н Офис 331