

ISL43210A

Medium-Voltage, Single Supply, Single SPDT Analog Switch

FN7876
Rev 0.00
Jun 24, 2011

The Intersil ISL43210A device is a precision, bidirectional, single SPDT analog switch designed to operate from a single +2.7V to +15V supply. Targeted applications include applications that require a +15V single supply such as 3D TV/Eyeware products and single supply +3.0V/+5V battery powered equipment that benefit from the devices' low power consumption (5μW), low leakage currents (10nA max), and fast switching speeds ($t_{ON} = 28ns$, $t_{OFF} = 20ns$). Cell phones, for example, often face ASIC functionality limitations. The number of analog input or GPIO pins may be limited and digital geometries are not well suited to analog switch performance. This device may be used to "mux-in" additional functionality while reducing ASIC design risk. It's small package alleviates board space limitations, making it an ideal solution.

The ISL43210A is a single committed SPDT, which is perfect for use in 2-to-1 multiplexer applications.

TABLE 1. FEATURES AT A GLANCE

	ISL43210A
SW 1/SW 2	SPDT or 2x1 MUX
12V r_{ON}	11Ω
12V t_{ON}/t_{OFF}	25ns/17ns
5V r_{ON}	19Ω
5V t_{ON}/t_{OFF}	28ns/20ns
3.3V r_{ON}	32Ω
3.3V t_{ON}/t_{OFF}	40ns/20ns
Package	6 Ld SOT-23

Related Literature

- Technical Brief [TB363](#) "Guidelines for Handling and Processing Moisture Sensitive Surface Mount Devices (SMDs)"
- Application Note [AN557](#) "Recommended Test Procedures for Analog Switches"

Features

- Fully specified at 1.2V, 5V, and 3.3V supplies for 10% tolerances
- ON-resistance (r_{ON}) 11Ω
- r_{ON} matching between channels <1Ω
- Low charge injection 5pC
- Single supply operation +2.7V to +15V
- Low leakage current 10nA
- Fast switching action
 - t_{ON} 25ns
 - t_{OFF} 17ns
- Guaranteed break-before-make switching
- Minimum 2000V ESD protection per method 3015.7
- TTL, CMOS compatible
- Available in 6 Ld SOT-23 package
- Pb-free (RoHS compliant)

Applications

- Battery-powered, handheld, and portable equipment
 - Cellular/mobile phones
 - Pagers
 - Laptops, notebooks, palmtops
- Communications systems
 - Radios, ADSL Modems
 - PBX, PABX
- Test and measurement equipment
 - Ultrasound
 - Computerized Tomography (CT) Scanner
 - Magnetic Resonance Image (MRI)
 - Positron Emission Tomography (PET) Scanner
 - Electrocardiograph
- Audio and Video switching
 - 3D TV
 - 3D Eyeware
- Various circuits
 - +3V/+5V DACs and ADCs
 - Sample and hold circuits
 - Digital filters
 - Operational amplifier gain switching networks
 - High frequency analog switching
 - High speed multiplexing
 - Integrator reset circuits

Pin Configuration (Note 1)

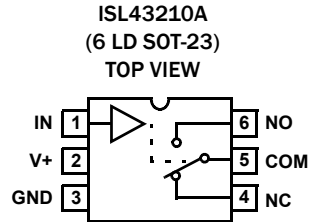

NOTE:

1. Switch Shown for Logic "0" Input.

Truth Table

LOGIC	ISL43210A	
	PIN NC	PIN NO
0	ON	OFF
1	OFF	ON

NOTE: Logic "0" $\leq 0.8V$. Logic "1" $\geq 2.4V$.

Pin Descriptions

PIN NAME	PIN NUMBER	FUNCTION
V+	2	System Power Supply Input (+2.7V to +15V)
GND	3	Ground Connection
IN	1	Digital Control Input
COM	5	Analog Switch Common Pin
NO	6	Analog Switch Normally Open Pin
NC	4	Analog Switch Normally Closed Pin

Ordering Information

PART NUMBER (Notes 2, 3, 4)	PART MARKING (Note 5)	TEMP. RANGE (°C)	PACKAGE (Pb-free)	PKG. DWG. #
ISL43210AIHZ-T	210A	-40 to +85	6 Ld SOT-23	P6.064
ISL43210AIHZ-T7A	210A	-40 to +85	6 Ld SOT-23	P6.064

NOTES:

2. Please refer to [TB347](#) for details on reel specifications.
3. These Intersil Pb-free plastic packaged products employ special Pb-free material sets, molding compounds/die attach materials, and 100% matte tin plate plus anneal (e3 termination finish, which is RoHS compliant and compatible with both SnPb and Pb-free soldering operations). Intersil Pb-free products are MSL classified at Pb-free peak reflow temperatures that meet or exceed the Pb-free requirements of IPC/JEDEC J STD-020.
4. For Moisture Sensitivity Level (MSL), please see device information page for [ISL43210A](#). For more information on MSL please see techbrief [TB363](#).
5. The part marking is located on the bottom of the part.

Absolute Maximum Ratings

V+ to GND	-0.3 to 16.5V
Input Voltages	
IN (Note 6)	-0.3 to ((V+) + 0.3V)
NO, NC (Note 6)	-0.3 to ((V+) + 0.3V)
Output Voltages	
COM (Note 6)	-0.3 to ((V+) + 0.3V)
Continuous Current (Any Terminal)	30mA
Peak Current NO, NC, or COM (Pulsed 1ms, 10% Duty Cycle, Max)	40mA
ESD Rating	
Human Body Model (Tested per JESD22-A114E)	2kV
Machine Model (Tested per JESD22-A115-A)	100V
Latch Up (Tested per JESD-78B; Class 2, Level A)	100mA

Thermal Information

Thermal Resistance (Typical)	θ_{JA} (°C/W)	θ_{JC} (°C/W)
6 Ld SOT-23 Package (Notes 7, 8)	175	95
Maximum Junction Temperature (Plastic Package)	+150°C	
Maximum Storage Temperature Range	-65°C to +150°C	
Pb-Free Reflow Profile	see link below http://www.intersil.com/pbfree/Pb-FreeReflow.asp	

Operating Conditions

Temperature Range	-40°C to +85°C
Maximum Operating Voltage	15V

CAUTION: Do not operate at or near the maximum ratings listed for extended periods of time. Exposure to such conditions may adversely impact product reliability and result in failures not covered by warranty.

NOTES:

- Signals on NC, NO, COM, or IN exceeding V+ or GND are clamped by internal diodes. Limit forward diode current to maximum current ratings.
- θ_{JA} is measured with the component mounted on a high effective thermal conductivity test board in free air. See Tech Brief [TB379](#) for details.
- For θ_{JC} , the "case temp" location is taken at the package top center.

Electrical Specifications - 12V Supply Test Conditions: V+ = +10.8V to +15V, GND = 0V, V_{INH} = 4V, V_{INL} = 0.8V (Note 9), Unless Otherwise Specified. **Boldface limits apply over the operating temperature range, -40°C to +85°C.**

PARAMETER	TEST CONDITIONS	TEMP (°C)	MIN (Notes 10, 11)	TYP	MAX (Notes 10, 11)	UNITS
ANALOG SWITCH CHARACTERISTICS						
Analog Signal Range, V_{ANALOG}		Full	0	-	V+	V
ON-Resistance, r_{ON}	V+ = 10.8V, I_{COM} = 1.0mA, V_{NO} or V_{NC} = 10V (see Figure 5)	25	-	11	20	Ω
		Full	-	15	25	Ω
r_{ON} Matching Between Channels, Δr_{ON}	V+ = 10.8V, I_{COM} = 1.0mA, V_{NO} or V_{NC} = 10V	25	-	0.8	2	Ω
		Full	-	1	4	Ω
r_{ON} Flatness, $R_{FLAT(ON)}$	V+ = 10.8V, I_{COM} = 1.0mA, V_{NO} or V_{NC} = 3V, 6V, 9V (Note 12)	25	-	1	4	Ω
		Full	-	-	6	Ω
NO or NC OFF Leakage Current, $I_{NO(OFF)}$ or $I_{NC(OFF)}$	V+ = 15V, V_{COM} = 1V, 12V, V_{NO} or V_{NC} = 12V, 1V	25	-3	0.01	3	nA
		Full	-5	-	5	nA
COM OFF Leakage Current, $I_{COM(OFF)}$	V+ = 15V, V_{COM} = 12V, 1V, V_{NO} or V_{NC} = 1V, 12V	25	-3	0.01	3	nA
		Full	-5	-	5	nA
COM ON Leakage Current, $I_{COM(ON)}$	V+ = 15V, V_{COM} = 1V, 12V, or V_{NO} or V_{NC} = 1V, 12V or floating	25	-5	-	5	nA
		Full	-10	-	10	nA
DYNAMIC CHARACTERISTICS						
Turn-ON Time, t_{ON}	V_{NO} or V_{NC} = 10V, R_L = 1k Ω , C_L = 35pF, V_{IN} = 0V to 4V (see Figure 1)	25	-	25	-	ns
		Full	-	35	-	ns
Turn-OFF Time, t_{OFF}	V_{NO} or V_{NC} = 10V, R_L = 1k Ω , C_L = 35pF, V_{IN} = 0V to 4V (see Figure 1)	25	-	17	-	ns
		Full	-	26	-	ns
Break-Before-Make Time Delay, t_D	R_L = 300 Ω , C_L = 35pF, V_{NO} or V_{NC} = 10V, V_{IN} = 0V to 4V (see Figure 3)	Full	-	2	-	ns
Charge Injection, Q	C_L = 1.0nF, V_G = 0V, R_G = 0 Ω (see Figure 2)	25	-	5	-	pC
OFF Isolation	R_L = 50 Ω , C_L = 5pF, f = 1MHz (see Figure 4)	25	-	76	-	dB

Electrical Specifications - 12V Supply Test Conditions: $V_+ = +10.8V$ to $+15V$, $GND = 0V$, $V_{INH} = 4V$, $V_{INL} = 0.8V$ (Note 9), Unless Otherwise Specified. **Boldface limits apply over the operating temperature range, $-40^\circ C$ to $+85^\circ C$.** (Continued)

PARAMETER	TEST CONDITIONS	TEMP ($^\circ C$)	MIN (Notes 10, 11)	TYP	MAX (Notes 10, 11)	UNITS
Crosstalk (Channel-to-Channel)	$R_L = 50\Omega$, $C_L = 5pF$, $f = 1MHz$ (see Figure 6)	25	-	- 105	-	dB
Power Supply Rejection Ratio	$R_L = 50\Omega$, $C_L = 5pF$, $f = 1MHz$	25	-	63	-	dB
NO or NC OFF Capacitance, C_{OFF}	$f = 1MHz$, V_{NO} or $V_{NC} = V_{COM} = 0V$ (see Figure 7)	25	-	8	-	pF
COM OFF Capacitance, $C_{COM(OFF)}$	$f = 1MHz$, V_{NO} or $V_{NC} = V_{COM} = 0V$ (see Figure 7)	25	-	8	-	pF
COM ON Capacitance, $C_{COM(ON)}$	$f = 1MHz$, V_{NO} or $V_{NC} = V_{COM} = 0V$ (See Figure 7)	25	-	28	-	pF
POWER SUPPLY CHARACTERISTICS						
Positive Supply Current, I_+	$V_+ = 15V$, $V_{IN} = 0V$ or V_+ , all channels on or off	Full	-1.8	-	1.8	μA
DIGITAL INPUT CHARACTERISTICS						
Input Voltage Low, V_{INL}		Full	-	-	0.8	V
Input Voltage High, V_{INH}		Full	4	-	-	V
Input Current, I_{INH} , I_{INL}	$V_+ = 15V$, $V_{IN} = 0V$ or V_+	Full	-1	-	1	μA

Electrical Specifications - 5V Supply Test Conditions: $V_+ = +4.5V$ to $+5.5V$, $GND = 0V$, $V_{INH} = 2.4V$, $V_{INL} = 0.8V$ (Note 9), Unless Otherwise Specified. **Boldface limits apply over the operating temperature range, $-40^\circ C$ to $+85^\circ C$.**

PARAMETER	TEST CONDITIONS	TEMP ($^\circ C$)	MIN (Notes 10, 11)	TYP	MAX (Notes 10, 11)	UNITS
ANALOG SWITCH CHARACTERISTICS						
Analog Signal Range, V_{ANALOG}		Full	0	-	V_+	V
ON-Resistance, r_{ON}	$V_+ = 4.5V$, $I_{COM} = 1.0mA$, V_{NO} or $V_{NC} = 3.5V$ (See Figure 5)	25	-	19	30	Ω
		Full	-	23	40	Ω
r_{ON} Matching Between Channels, Δr_{ON}	$V_+ = 5V$, $I_{COM} = 1.0mA$, V_{NO} or $V_{NC} = 3.5V$	25	-	0.8	2	Ω
		Full	-	1	4	Ω
r_{ON} Flatness, $R_{FLAT(ON)}$	$V_+ = 5V$, $I_{COM} = 1.0mA$, V_{NO} or $V_{NC} = 1V, 2V, 3V$ (Note 12)	Full	-	7	8	Ω
NO or NC OFF Leakage Current, $I_{NO(OFF)}$ or $I_{NC(OFF)}$	$V_+ = 5.5V$, $V_{COM} = 1V, 4.5V$, V_{NO} or $V_{NC} = 4.5V, 1V$	25	-3	0.01	3	nA
		Full	-5	-	5	nA
COM OFF Leakage Current, $I_{COM(OFF)}$	$V_+ = 5.5V$, $V_{COM} = 4.5V, 1V$, V_{NO} or $V_{NC} = 1V, 4.5V$	25	-3	-	3	nA
		Full	-5	-	5	nA
COM ON Leakage Current, $I_{COM(ON)}$	$V_+ = 5.5V$, $V_{COM} = 1V, 4.5V$, or V_{NO} or $V_{NC} = 1V, 4.5V$ or Floating	25	-5	-	5	nA
		Full	-10	-	10	nA
DYNAMIC CHARACTERISTICS						
Turn-ON Time, t_{ON}	V_{NO} or $V_{NC} = 3V$, $R_L = 1k\Omega$, $C_L = 35pF$, $V_{IN} = 0V$ to $3V$ (See Figure 1)	25	-	28	-	ns
		Full	-	40	-	ns
Turn-OFF Time, t_{OFF}	V_{NO} or $V_{NC} = 3V$, $R_L = 1k\Omega$, $C_L = 35pF$, $V_{IN} = 0V$ to $3V$ (See Figure 1)	25	-	20	-	ns
		Full	-	30	-	ns
Break-Before-Make Time Delay, t_D	$R_L = 300\Omega$, $C_L = 35pF$, $V_{NO} = V_{NC} = 3V$, $V_{IN} = 0V$ to $3V$ (See Figure 3)	Full	-	10	-	ns
Charge Injection, Q	$C_L = 1.0nF$, $V_G = 0V$, $R_G = 0\Omega$ (See Figure 2)	25	-	3	-	pC
OFF Isolation	$R_L = 50\Omega$, $C_L = 5pF$, $f = 1MHz$ (See Figure 4)	25	-	76	-	dB

Electrical Specifications - 5V Supply Test Conditions: $V_+ = +4.5V$ to $+5.5V$, $GND = 0V$, $V_{INH} = 2.4V$, $V_{INL} = 0.8V$ (Note 9), Unless Otherwise Specified. **Boldface limits apply over the operating temperature range, $-40^\circ C$ to $+85^\circ C$.** (Continued)

PARAMETER	TEST CONDITIONS	TEMP (°C)	MIN (Notes 10, 11)	TYP	MAX (Notes 10, 11)	UNITS
Power Supply Rejection Ratio	$R_L = 50\Omega$, $C_L = 5pF$, $f = 1MHz$	25	-	60	-	dB
NO or NC OFF Capacitance, C_{OFF}	$f = 1MHz$, V_{NO} or $V_{NC} = V_{COM} = 0V$ (See Figure 7)	25	-	8	-	pF
COM OFF Capacitance, $C_{COM(OFF)}$	$f = 1MHz$, V_{NO} or $V_{NC} = V_{COM} = 0V$ (See Figure 7)	25	-	8	-	pF
COM ON Capacitance, $C_{COM(ON)}$	$f = 1MHz$, V_{NO} or $V_{NC} = V_{COM} = 0V$ (See Figure 7)	25	-	28	-	pF
POWER SUPPLY CHARACTERISTICS						
Power Supply Range		Full	2.7	-	15	V
Positive Supply Current, I_+	$V_+ = 5.5V$, $V_{IN} = 0V$ or V_+ , all channels on or off	Full	-1	0.0001	1	μA
DIGITAL INPUT CHARACTERISTICS						
Input Voltage Low, V_{INL}		Full	-	-	0.8	V
Input Voltage High, V_{INH}		Full	2.4	-	-	V
Input Current, I_{INH} , I_{INL}	$V_+ = 5.5V$, $V_{IN} = 0V$ or V_+	Full	-1	-	1	μA

Electrical Specifications - 2.7V to 5.5V Supply Test Conditions: $V_+ = +3.0V$ to $+3.6V$, $GND = 0V$, $V_{INH} = 2.4V$, $V_{INL} = 0.8V$ (Note 9), Unless Otherwise Specified. **Boldface limits apply over the operating temperature range, $-40^\circ C$ to $+85^\circ C$.**

PARAMETER	TEST CONDITIONS	TEMP (°C)	MIN (Notes 10, 11)	TYP	MAX (Notes 10, 11)	UNITS
ANALOG SWITCH CHARACTERISTICS						
Analog Signal Range, V_{ANALOG}		Full	0	-	V_+	V
ON-Resistance, r_{ON}	$V_+ = 3V$, $I_{COM} = 1.0mA$, V_{NO} or $V_{NC} = 1.5V$ (see Figure 5)	25	-	32	50	Ω
r_{ON} Matching Between Channels, Δr_{ON}	$V_+ = 3.3V$, $I_{COM} = 1.0mA$, V_{NO} or $V_{NC} = 1.5V$	Full	-	40	60	Ω
		25	-	0.8	2	Ω
r_{ON} Flatness, $R_{FLAT(ON)}$	$V_+ = 3.3V$, $I_{COM} = 1.0mA$, V_{NO} or $V_{NC} = 0.5V, 1V, 1.5V$ (Note 12)	Full	-	1	4	Ω
		25	-	6	10	Ω
NO or NC OFF Leakage Current, $I_{NO(OFF)}$ or $I_{NC(OFF)}$	$V_+ = 3.6V$, $V_{COM} = 1V, 3V$, V_{NO} or $V_{NC} = 3V, 1V$	Full	-3	0.01	3	nA
		25	-5	-	5	nA
COM OFF Leakage Current, $I_{COM(OFF)}$	$V_+ = 3.6V$, $V_{COM} = 3V, 1V$, V_{NO} or $V_{NC} = 1V, 3V$	Full	-3	0.01	3	nA
		25	-5	-	5	nA
COM ON Leakage Current, $I_{COM(ON)}$	$V_+ = 3.6V$, $V_{COM} = 1V, 3V$, or V_{NO} or $V_{NC} = 1V, 3V$ or floating	Full	-5	-	5	nA
		25	-10	-	10	nA
DYNAMIC CHARACTERISTICS						
Turn-ON Time, t_{ON}	V_{NO} or $V_{NC} = 1.5V$, $R_L = 1k\Omega$, $C_L = 35pF$, $V_{IN} = 0V$ to $3V$ (see Figure 1)	Full	-	40	-	ns
		25	-	60	-	ns
Turn-OFF Time, t_{OFF}	V_{NO} or $V_{NC} = 1.5V$, $R_L = 1k\Omega$, $C_L = 35pF$, $V_{IN} = 0V$ to $3V$ (see Figure 1)	Full	-	20	-	ns
		25	-	30	-	ns
Break-Before-Make Time Delay, t_D	$R_L = 300\Omega$, $C_L = 35pF$, V_{NO} or $V_{NC} = 1.5V$, $V_{IN} = 0V$ to $3V$ (see Figure 3)	Full	-	20	-	ns
Charge Injection, Q	$C_L = 1.0nF$, $V_G = 0V$, $R_G = 0\Omega$ (see Figure 2)	25	-	1	-	pC
OFF Isolation	$R_L = 50\Omega$, $C_L = 5pF$, $f = 1MHz$ (see Figure 4)	25	-	76	-	dB
Power Supply Rejection Ratio	$R_L = 50\Omega$, $C_L = 5pF$, $f = 1MHz$	25	-	56	-	dB
NO or NC OFF Capacitance, C_{OFF}	$f = 1MHz$, V_{NO} or $V_{NC} = V_{COM} = 0V$ (see Figure 7)	25	-	8	-	pF

Electrical Specifications - 2.7V to 5.5V Supply Test Conditions: $V+ = +3.0V$ to $+3.6V$, $GND = 0V$, $V_{INH} = 2.4V$, $V_{INL} = 0.8V$ (Note 9), Unless Otherwise Specified. **Boldface limits apply over the operating temperature range, $-40^{\circ}C$ to $+85^{\circ}C$.** (Continued)

PARAMETER	TEST CONDITIONS	TEMP (°C)	MIN (Notes 10, 11)	TYP	MAX (Notes 10, 11)	UNITS
COM OFF Capacitance, $C_{COM(OFF)}$	$f = 1MHz$, V_{NO} or $V_{NC} = V_{COM} = 0V$ (see Figure 7)	25	-	8	-	pF
COM ON Capacitance, $C_{COM(ON)}$	$f = 1MHz$, V_{NO} or $V_{NC} = V_{COM} = 0V$ (See Figure 7)	25	-	28	-	pF
POWER SUPPLY CHARACTERISTICS						
Positive Supply Current, $I+$	$V+ = 3.6V$, $V_{IN} = 0V$ or $V+$, all channels on or off	Full	-1	-	1	μA
DIGITAL INPUT CHARACTERISTICS						
Input Voltage Low, V_{INL}		Full	-	-	0.8	V
Input Voltage High, V_{INH}		Full	2.4	-	-	V
Input Current, I_{INH} , I_{INL}	$V+ = 3.6V$, $V_{IN} = 0V$ or $V+$	Full	-1	-	1	μA

NOTES:

- 9. V_{IN} = input voltage to perform proper function.
- 10. The algebraic convention, whereby the most negative value is a minimum and the most positive a maximum, is used in this data sheet.
- 11. Compliance to datasheet limits is assured by one or more methods: production test, characterization and/or design.
- 12. Limits established by characterization and are not production tested.

Test Circuits and Waveforms

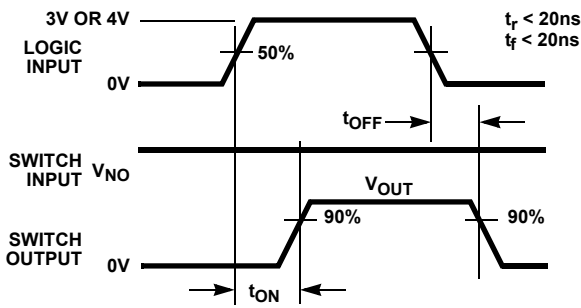

Logic input waveform is inverted for switches that have the opposite logic sense.

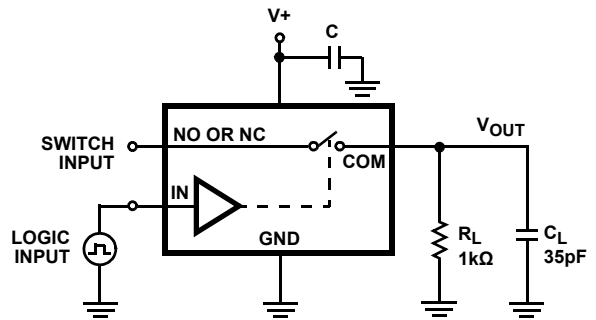

Repeat test for all switches. C_L includes fixture and stray capacitance.

$$V_{OUT} = V_{(NO \text{ or } NC)} \frac{R_L}{R_L + r_{ON}}$$

FIGURE 1A. MEASUREMENT POINTS

FIGURE 1. SWITCHING TIMES

FIGURE 1B. TEST CIRCUIT

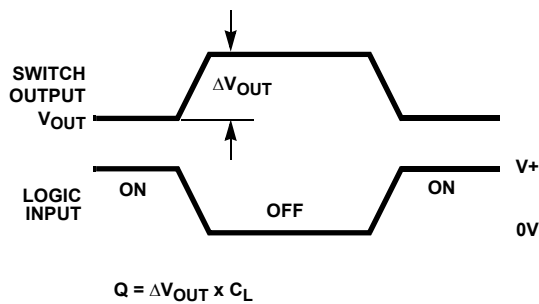

FIGURE 2A. MEASUREMENT POINTS

FIGURE 2. CHARGE INJECTION

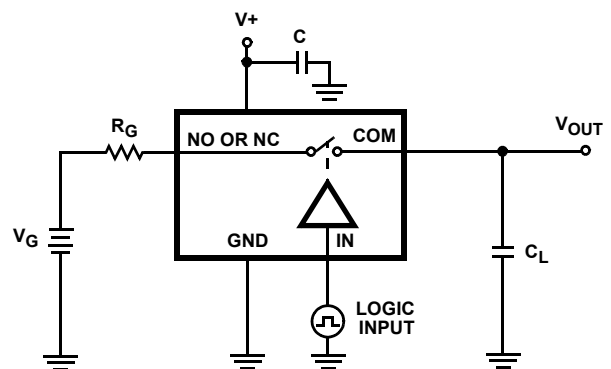

FIGURE 2B. TEST CIRCUIT

Test Circuits and Waveforms (Continued)

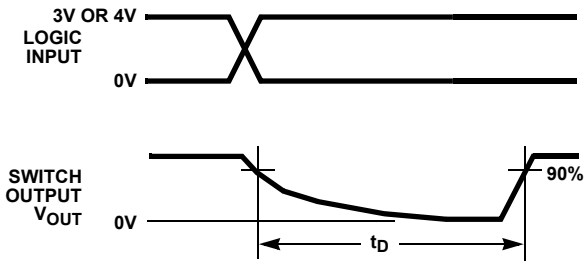
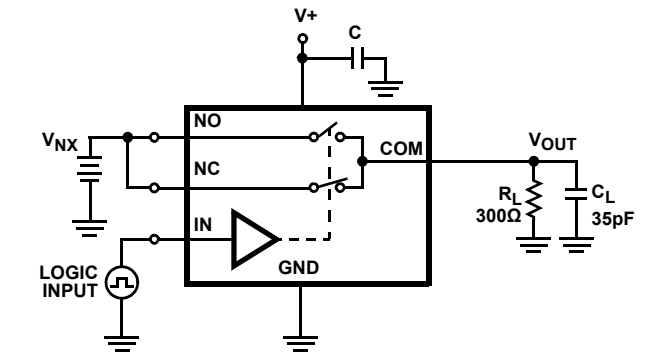

FIGURE 3A. MEASUREMENT POINTS



C_L includes fixture and stray capacitance.

FIGURE 3B. TEST CIRCUIT

FIGURE 3. BREAK-BEFORE-MAKE TIME

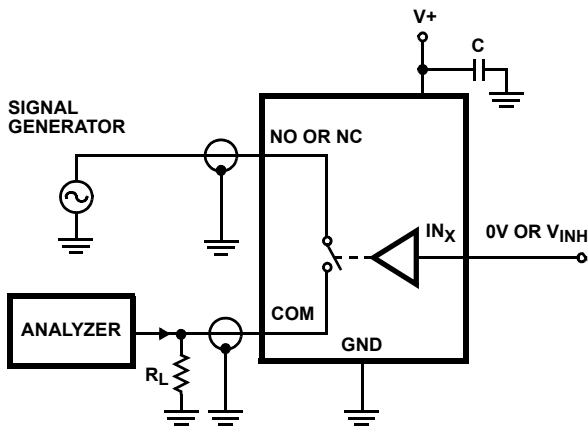

FIGURE 4. OFF ISOLATION TEST CIRCUIT

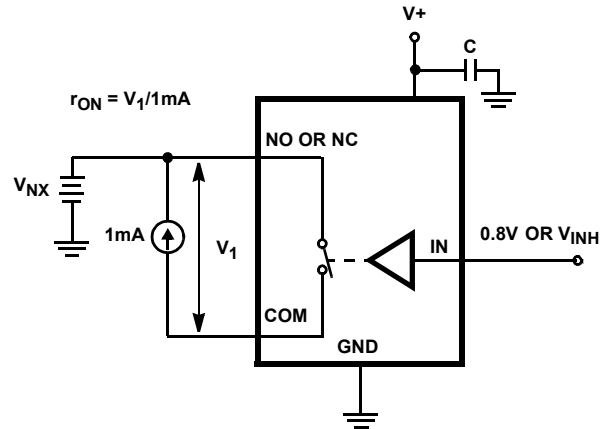

FIGURE 5. r_{ON} TEST CIRCUIT

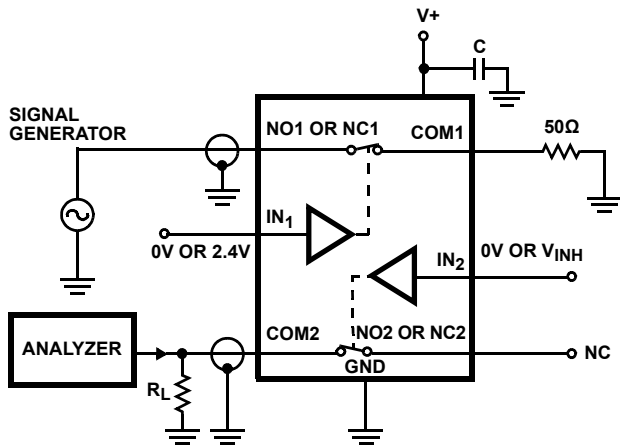

FIGURE 6. CROSSTALK TEST CIRCUIT

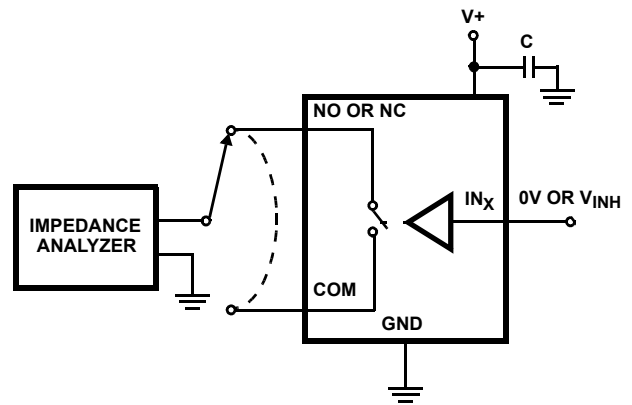

FIGURE 7. CAPACITANCE TEST CIRCUIT

Detailed Description

The ISL43210A bidirectional, single SPDT analog switch offers precise switching capability from a single 2.7V to 15V supply with low ON-resistance (1.1 Ω) and high speed operation.

The device is especially well suited for 3D TV and 3D eyeware equipment thanks to the high single supply operating voltage (15V), low power consumption (27 μ W max), fast switching speed ($t_{ON} = 25$ ns, $t_{OFF} = 17$ ns), and the tiny SOT-23 packaging. High frequency applications also benefit from the wide bandwidth and the very high off isolation rejection.

Supply Sequencing and Overvoltage Protection

With any CMOS device, proper power supply sequencing is required to protect the device from excessive input currents that might permanently damage the IC. All I/O pins contain ESD protection diodes from the pin to V+ and GND (see Figure 8). To prevent forward biasing these diodes, V+ must be applied before any input signals, and input signal voltages must remain between V+ and GND. If these conditions cannot be guaranteed, then one of the following two protection methods should be employed.

Logic inputs can easily be protected by adding a 1k Ω resistor in series with the input (see Figure 8). The resistor limits the input current below the threshold that produces permanent damage, and the sub-microamp input current produces an insignificant voltage drop during normal operation.

Adding a series resistor to the switch input defeats the purpose of using a low r_{ON} switch, so two small signal diodes can be added in series with the supply pins to provide overvoltage protection for all pins (see Figure 8). These additional diodes limit the analog signal from 1V below V+ to 1V above GND. The low leakage current performance is unaffected by this approach, but the switch resistance may increase, especially at low supply voltages.

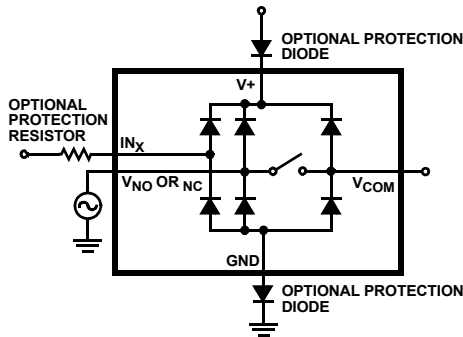

FIGURE 8. OVERVOLTAGE PROTECTION

Power-Supply Considerations

The ISL43210A construction is typical of most CMOS analog switches, except that it has only two supply pins: V+ and GND. V+ and GND drive the internal CMOS switches and set their analog voltage limits. Unlike switches with a 1.3V absolute maximum voltage, the ISL43210A 16.5V absolute maximum supply voltage provides plenty of room for the 10% tolerance of 15V supplies, as well as room for overshoot and noise spikes.

The minimum recommended supply voltage is 2.7V. It is important to note that the input signal range, switching times, and ON-resistance degrade at lower supply voltages. Refer to the “Electrical Specification” tables beginning on page 3 and “Typical Performance Curves” beginning on page 9 for details.

V+ and GND also power the internal logic and level shifter. The level shifter converts the input logic levels to switch V+ and GND signals to drive the analog switch gate terminals.

This device cannot be operated with bipolar supplies because the input switching point becomes negative in this configuration.

Logic-Level Thresholds

This switch is TTL compatible (0.8V and 2.4V) over a supply range of 3V to 11V (see Figure 15). At 12V the V_{IH} level is about 2.5V. This is still below the TTL guaranteed high output minimum level of 2.8V, but noise margin is reduced. For best results with a 12V supply, use a logic family that provides a V_{OH} greater than 3V.

The digital input stages draw supply current whenever the digital input voltage is not at one of the supply rails. Driving the digital input signals from GND to V+ with a fast transition time minimizes power dissipation.

High-Frequency Performance

In 50 Ω systems, signal response is reasonably flat even past 300MHz (see Figure 16). Figure 16 also illustrates that the frequency response is very consistent over a wide V+ range, and for varying analog signal levels.

An OFF switch acts like a capacitor and passes higher frequencies with less attenuation, resulting in signal feed-through from a switch’s input to its output. Off isolation is the resistance to this feed-through. Figure 17 details the high off isolation rejection provided by this part. At 10MHz, off isolation is about 50dB in 50 Ω systems, decreasing approximately 20dB per decade as frequency increases. Higher load impedances decrease off isolation rejection due to the voltage divider action of the switch OFF impedance and the load impedance.

Leakage Considerations

Reverse ESD protection diodes are internally connected between each analog-signal pin and both V+ and GND. One of these diodes conducts if any analog signal exceeds V+ or GND.

Virtually all the analog leakage current comes from the ESD diodes to V+ or GND. Although the ESD diodes on a given signal pin are identical and therefore fairly well balanced, they are reverse biased differently. Each is biased by either V+ or GND and the analog signal. This means their leakages will vary as the signal varies. The difference in the two diode leakages to the V+ and GND pins constitutes the analog-signal-path leakage current. All analog leakage current flows between each pin and one of the supply terminals, not to the other switch terminal. This is why both sides of a given switch can show leakage currents of the same or opposite polarity. There is no connection between the analog signal paths and V+ or GND.

Typical Performance Curves $T_A = +25^\circ\text{C}$, Unless Otherwise Specified.

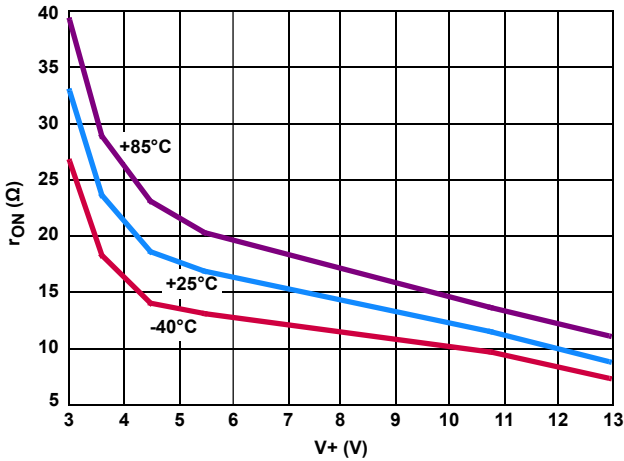

FIGURE 9. ON-RESISTANCE vs SUPPLY VOLTAGE

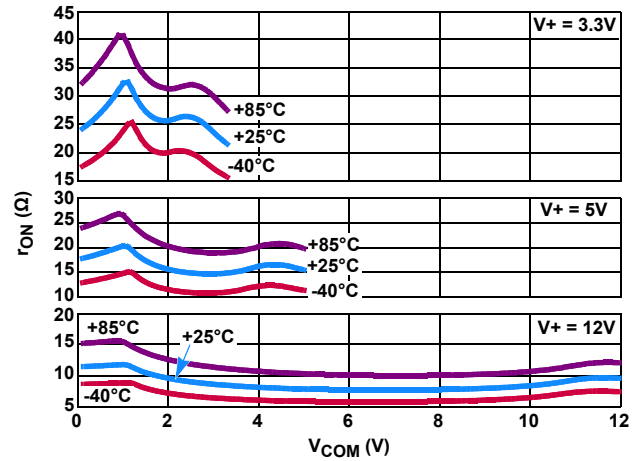

FIGURE 10. ON-RESISTANCE vs SWITCH VOLTAGE

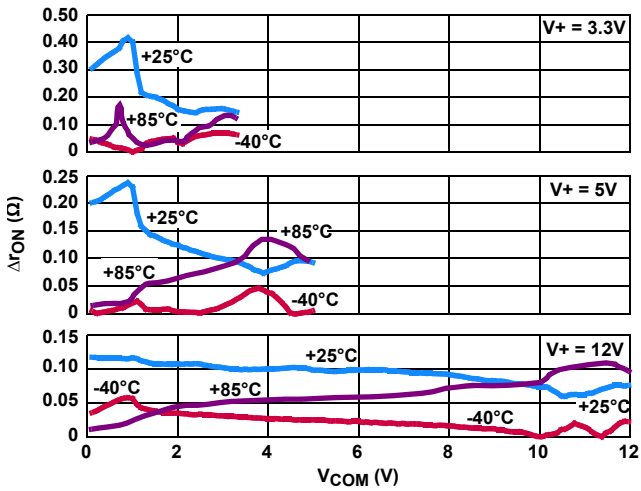

FIGURE 11. r_{ON} MATCH vs SWITCH VOLTAGE

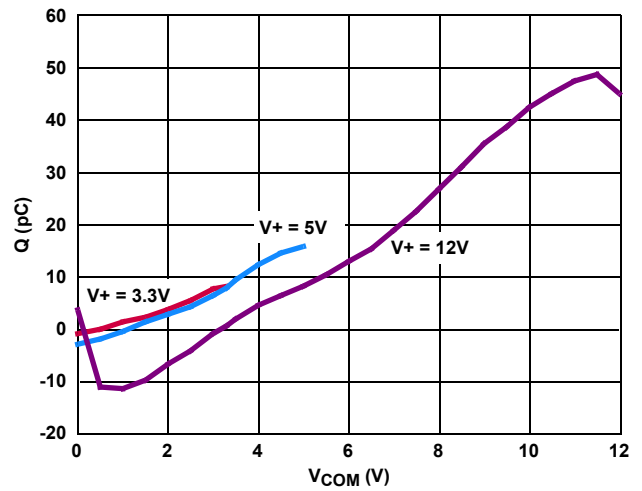

FIGURE 12. CHARGE INJECTION vs SWITCH VOLTAGE

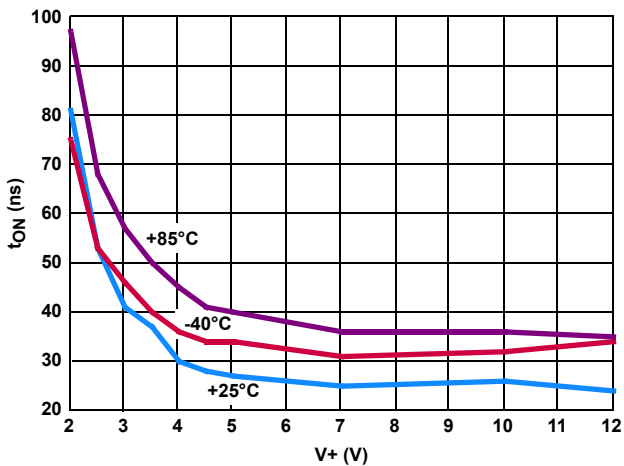

FIGURE 13. TURN-ON TIME vs SUPPLY VOLTAGE

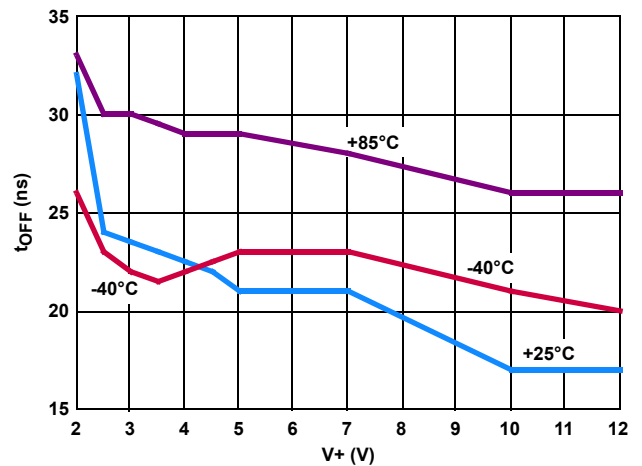

FIGURE 14. TURN-OFF TIME vs SUPPLY VOLTAGE

Typical Performance Curves $T_A = +25^\circ\text{C}$, Unless Otherwise Specified. (Continued)

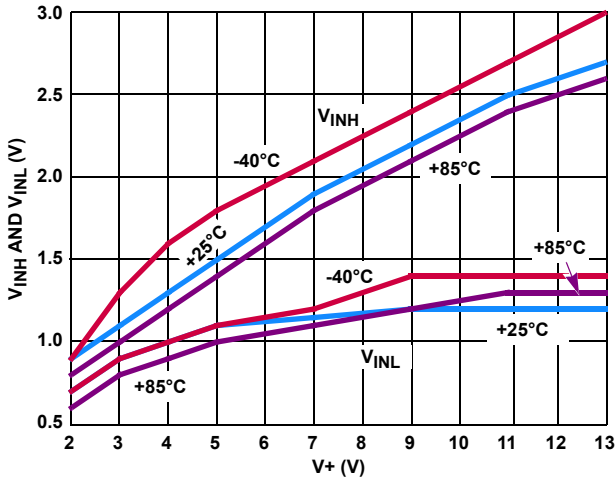

FIGURE 15. DIGITAL SWITCHING POINT vs SUPPLY VOLTAGE

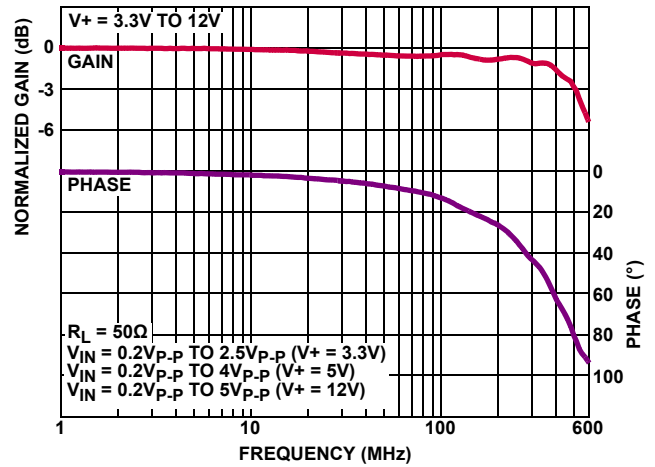

FIGURE 16. FREQUENCY RESPONSE

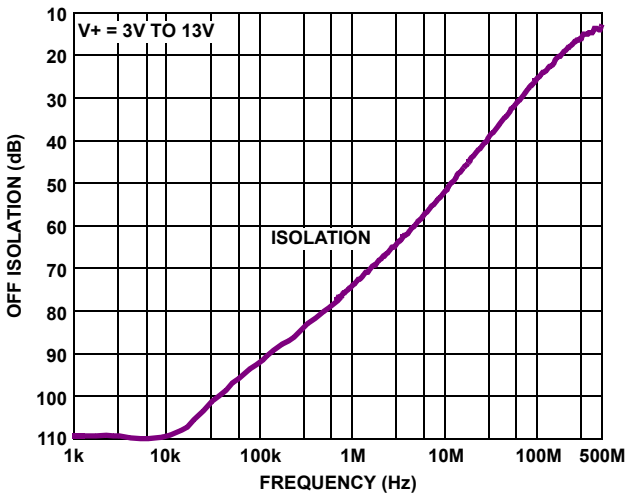

FIGURE 17. OFF ISOLATION

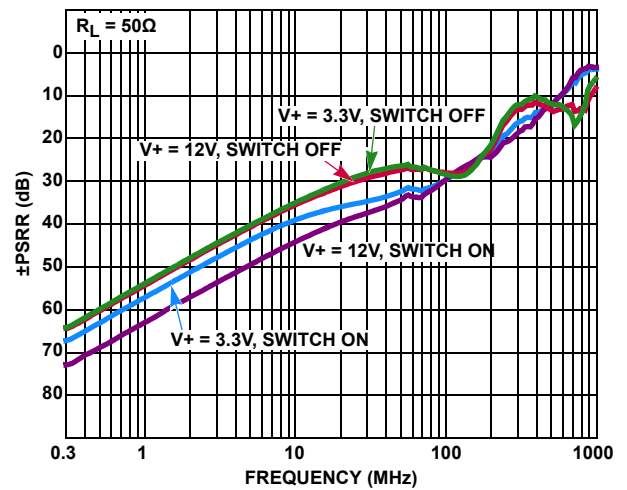

FIGURE 18. \pm PSRR vs FREQUENCY

Die Characteristics

SUBSTRATE POTENTIAL (POWERED UP):

GND

TRANSISTOR COUNT:

ISL43210A: 58

PROCESS:

Si Gate CMOS

Revision History

The revision history provided is for informational purposes only and is believed to be accurate, but not warranted. Please go to web to make sure you have the latest revision.

DATE	REVISION	CHANGE
June 24, 2011	FN7876.0	Initial release

Products

Intersil Corporation is a leader in the design and manufacture of high-performance analog semiconductors. The Company's products address some of the industry's fastest growing markets, such as, flat panel displays, cell phones, handheld products, and notebooks. Intersil's product families address power management and analog signal processing functions. Go to www.intersil.com/products for a complete list of Intersil product families.

*For a complete listing of Applications, Related Documentation and Related Parts, please see the respective device information page on intersil.com: [ISL43210A](http://www.intersil.com/ISL43210A)

To report errors or suggestions for this datasheet, please go to: www.intersil.com/askourstaff

FITs are available from our website at: <http://rel.intersil.com/reports/search.php>

© Copyright Intersil Americas LLC 2011. All Rights Reserved.

All trademarks and registered trademarks are the property of their respective owners.

For additional products, see www.intersil.com/en/products.html

Intersil products are manufactured, assembled and tested utilizing ISO9001 quality systems as noted in the quality certifications found at www.intersil.com/en/support/qualandreliability.html

Intersil products are sold by description only. Intersil may modify the circuit design and/or specifications of products at any time without notice, provided that such modification does not, in Intersil's sole judgment, affect the form, fit or function of the product. Accordingly, the reader is cautioned to verify that datasheets are current before placing orders. Information furnished by Intersil is believed to be accurate and reliable. However, no responsibility is assumed by Intersil or its subsidiaries for its use; nor for any infringements of patents or other rights of third parties which may result from its use. No license is granted by implication or otherwise under any patent or patent rights of Intersil or its subsidiaries.

For information regarding Intersil Corporation and its products, see www.intersil.com

Package Outline Drawing

P6.064

6 LEAD SMALL OUTLINE TRANSISTOR PLASTIC PACKAGE

Rev 4, 2/10

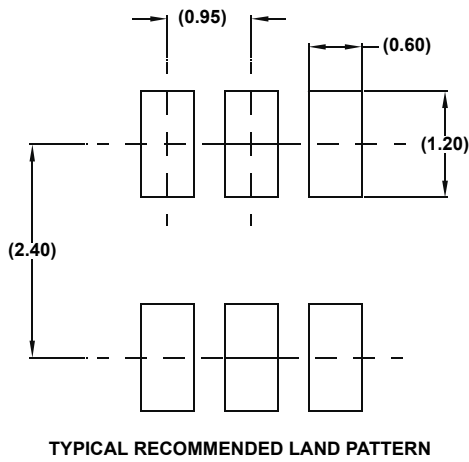
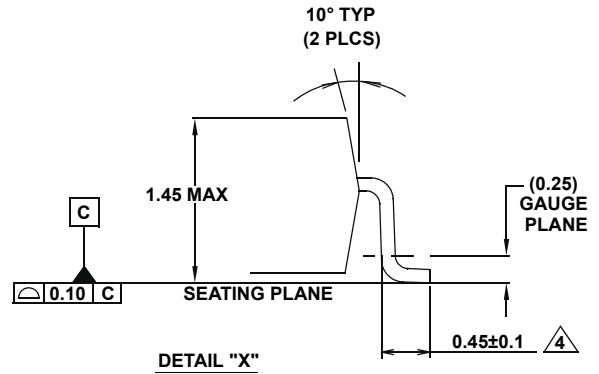
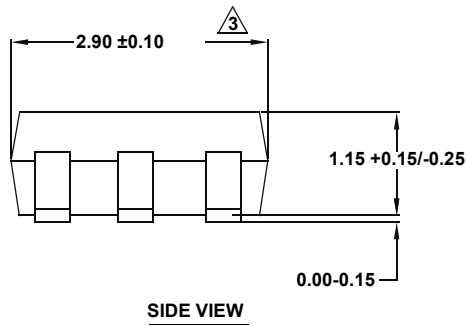
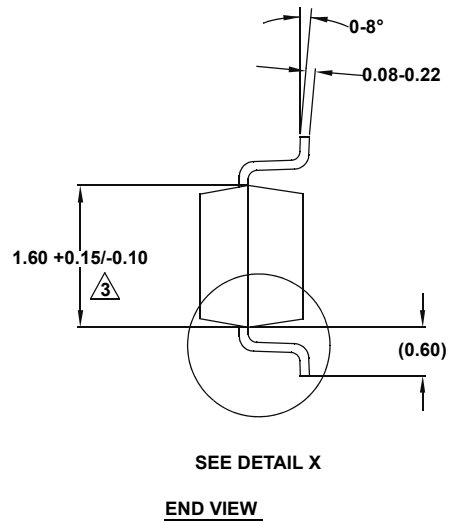
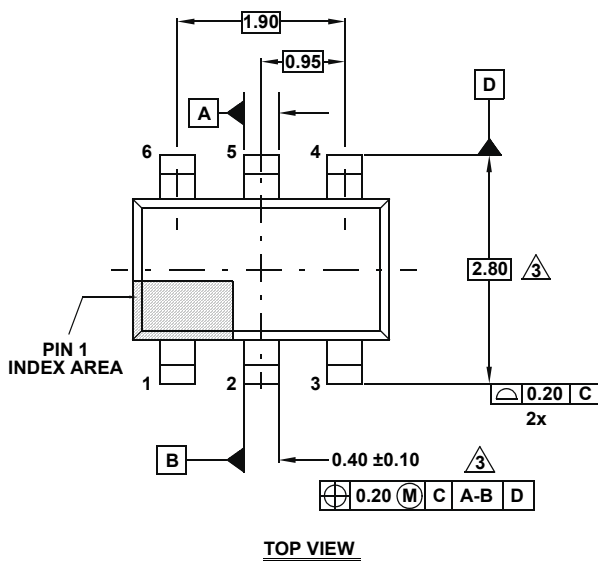

NOTES:

1. Dimensions are in millimeters.
Dimensions in () for Reference Only.
2. Dimensioning and tolerancing conform to ASME Y14.5M-1994.
3. Dimension is exclusive of mold flash, protrusions or gate burrs.
4. Foot length is measured at reference to gauge plane.
5. Package conforms to JEDEC MO-178AB.



Стандарт Электрон Связь

Мы молодая и активно развивающаяся компания в области поставок электронных компонентов. Мы поставляем электронные компоненты отечественного и импортного производства напрямую от производителей и с крупнейших складов мира.

Благодаря сотрудничеству с мировыми поставщиками мы осуществляем комплексные и плановые поставки широчайшего спектра электронных компонентов.

Собственная эффективная логистика и склад в обеспечивает надежную поставку продукции в точно указанные сроки по всей России.

Мы осуществляем техническую поддержку нашим клиентам и предпродажную проверку качества продукции. На все поставляемые продукты мы предоставляем гарантию .

Осуществляем поставки продукции под контролем ВП МО РФ на предприятия военно-промышленного комплекса России , а также работаем в рамках 275 ФЗ с открытием отдельных счетов в уполномоченном банке. Система менеджмента качества компании соответствует требованиям ГОСТ ISO 9001.

Минимальные сроки поставки, гибкие цены, неограниченный ассортимент и индивидуальный подход к клиентам являются основой для выстраивания долгосрочного и эффективного сотрудничества с предприятиями радиоэлектронной промышленности, предприятиями ВПК и научно-исследовательскими институтами России.

С нами вы становитесь еще успешнее!

Наши контакты:

Телефон: +7 812 627 14 35

Электронная почта: sales@st-electron.ru

Адрес: 198099, Санкт-Петербург,
Промышленная ул, дом № 19, литера Н,
помещение 100-Н Офис 331