



ON Semiconductor®

September 2017

FSA4476 — USB Type-C analog audio switch with protection function

Features

- Power Management
 - Primary power supply: VBAT, 2.7 V to 5.5 V
 - Second power supply VBUS, 4.0 V to 20 V
- USB High Speed(480Mbps) Switch:
 - -3dB bandwidth: 1 GHz
 - $3\Omega_{ON}$ Typical
- Audio switch
 - Negative rail capability: -3V to +3V
 - THD+N = -110 dB; 1 V_{RMS} , $f=20\text{Hz}\sim 20\text{kHz}$, 32Ω Load;
 - $0.6\Omega_{ON}$ Typical
- High voltage protection
 - 20V DC protection on CC port and SBU port
 - 16V DC protection on DP/R and DN/L port
- Over Voltage Protection:
 - 5.8V (Typ) on CC port
 - 4.5V (Typ) on SBU port
 - 4.5V (Typ) on DP/R and DN/L port
- OMTP and CTIA pinout support
- Support Audio Sense Path
- Support Dead Battery
- 25-ball WLCSP Package (2.03mm x 2.03mm)

Applications

- Mobile Phone, Tablet, Notebook PC, Media Player

Description

FSA4476 is a high performance USB Type-C port multimedia switch which supports analog audio headsets. FSA4476 allows the sharing of a common USB Type-C port to pass USB2.0 signal, analog audio, sideband use wires and analog microphone signal. FSA4476 also supports high voltage on CC port, SBU port and USB port on USB Type-C receptacle side. In addition, FSA4476 supports USB Type-C dead battery application and dual power supply with VBAT rail and VBUS rail.

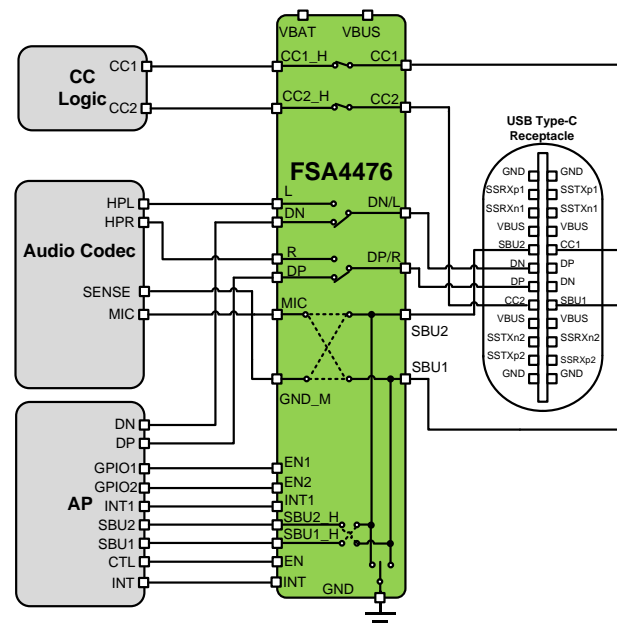

Figure 1. Application Block Diagram

FSA4476 — USB Type-C analog audio switch with protection function

Ordering Information

Part Number	Top Mark	Package Description
FSA4476UCX	GR	25 Ball WLCSP

Pin Configuration

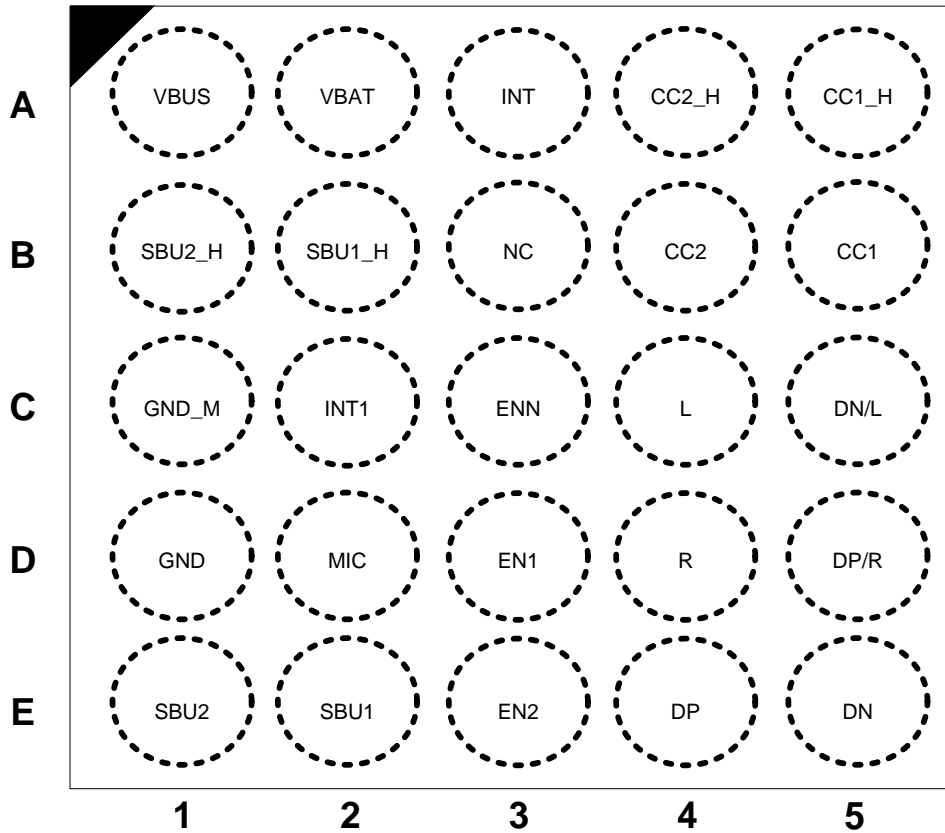

Figure 2. Pin Assignment (Top Through View)

Pin Descriptions

Name	Ball	Description
VBUS	A1	Power Supply
VBAT	A2	Power Supply
GND	D1	Ground
DP/R	D5	USB Positive Data/Right Audio Common Line
DN/L	C5	USB Negative Data/Left Audio Common Line
DP	E4	Positive DataLine for USB signals
DN	E5	Negative DataLine for USB signals
L	C4	Left Line for Audio Signals
R	D4	Right Line for Audio Signals
SBU1	E2	Sideband Use Wire 1 Common Line
SBU2	E1	Sideband Use Wire 2 Common Line
MIC	D2	Microphone, connects to microphone pre-amplifier
GND_M	C1	Sense Pin to Detect GND offset
SBU1_H	B2	Host Side Sideband Use Wire 1

Name	Ball	Description
SBU2_H	B1	Host Side Sideband Use Wire 2
CC1	B5	Configuration Channel 1
CC2	B4	Configuration Channel 2
CC1_H	A5	Host Side Configuration Channel 1
CC2_H	A4	Host Side Configuration Channel 2
INT	A3	OVP Interrupt Output, active low(open drain)
INT1	C2	Interrupt Output Signal; During EN1=1, INT1 is low active (open drain output) when CC1_H <1.2V and CC2_H <1.2V.
ENN	C3	Chip Enable, active low, internal pull-down by 1Mohm.
EN1	D3	Logic Configuration Input 1
EN2	E3	Logic Configuration Input 2
NC	B3	No Connect

Truth Table

Power	ENN	EN1,EN2	CC switch	Headset detection	USB switch	Audio switch	MIC SW / GND_M SW	SBU bypass switch
OFF	X	XX	Dead battery	OFF	OFF	OFF	OFF	OFF
ON	H	XX	OFF	OFF	OFF	OFF	OFF	OFF
ON	L	00	ON	OFF	ON: DP/R to DP DN/L to DN	OFF	OFF	ON: SBU1 to SBU1_H SBU2 to SBU2_H
ON	L	01	ON	OFF	ON: DP/R to DP DN/L to DN	OFF	OFF	ON: SBU1 to SBU2_H SBU2 to SBU1_H
ON	L	10	ON	ON	OFF	ON: DP/R to R DN/L to L	ON: SBU1 to MIC SBU2 to GND_M SBU2 to GND	OFF
ON	L	11	ON	ON	OFF	ON: DP/R to R DN/L to L	ON: SBU2 to MIC SBU1 to GND_M SBU1 to GND	OFF

Absolute Maximum Ratings

Stresses exceeding the absolute maximum ratings may damage the device. The device may not function or be operable above the recommended operating conditions and stressing the parts to these levels is not recommended. In addition, extended exposure to stresses above the recommended operating conditions may affect device reliability. The absolute maximum ratings are stress ratings only.

Symbol	Parameter	Min.	Max.	Unit	
V _{BAT}	Supply Voltage from VBAT	-0.5	6.5	V	
VBUS	Supply Voltage from VBUS	-0.5	28	V	
V _{VICC}	V _{CCx} , to GND	-0.5	20	V	
V _{VCC_H}	V _{CCx_H} , to GND	-0.5	6.5	V	
V _{SW_USB/Audio}	V _{DP_R} to GND, V _{DN_L} to GND	-3.5	16	V	
V _{SW_USB}	V _{DP} to GND, V _{DN} to GND	-0.5	6.5	V	
V _{SW_Audio}	V _L to GND, V _R to GND,	-3.5	+3.5	V	
V _{SBU}	V _{SBU1} to GND, V _{SBU2} to GND,	-0.5	20	V	
V _{SBU_H}	V _{SBU1_H} to GND, V _{SBU2_H} to GND,	-0.5	6.5	V	
V _{IO}	MIC, GND_M, INT, INT1 to GND,	-0.5	6.5	V	
V _{CNTRL}	Control Input Voltage	ENN, ENx	-0.5	6.5	V
I _{CCSW}	CC Switch Current		1.25	A	
I _{SW_Audio}	Switch I/O Current, Audio path,	-250	250	mA	
I _{SW_USB}	Switch I/O Current, USB path,		100	mA	
I _{SW_MIC}	Switch I/O Current, MIC to SBU1 or SBU2		50	mA	
I _{SW_GND_M}	Switch I/O Current, GND_M to SBU1 or SBU2		100	mA	
I _{SW_GND}	Switch I/O Current, GND to SBU1 or SBU2		500	mA	
I _{IK}	DC Input Diode Current	-50		mA	
ESD	Human Body Model, ANSI/ESDA/JEDEC JS-001-2012	Connector side and power pins: VBUS, V _{BAT} , CC1, CC2, SBU1, SBU2, DP/R, DN/L	4	kV	
		Host side pins: the rest pins	2		
	Charged Device Model, JEDEC: JESD22-C101	1			
T _A	Absolute Maximum Operating Temperature	-40	+85	°C	
T _{STG}	Storage Temperature	-65	+150	°C	

Recommended Operating Conditions

The Recommended Operating Conditions table defines the conditions for actual device operation. Recommended operating conditions are specified to ensure optimal performance. Onsemi does not recommend exceeding them or designing to Absolute Maximum Ratings.

Symbol	Parameter	Min.	Typ.	Max.	Unit
Power					
VBAT	Supply Voltage	2.7		5.5	V
VBUS	Supply Voltage	4.0		20	V
USB Switch					
V _{SW_USB}	V _{DP} to GND, V _{DN} to GND, V _{DP/R} to GND, V _{DN/L} to GND	0		4.0	V
Audio Switch					
V _{SW_Audio}	V _{DP/R} to GND, V _{DN/L} to GND, V _L to GND, V _R to GND	-3		+3	V

Symbol	Parameter	Min.	Typ.	Max.	Unit
V_{SW_MIC}	MIC to GND	0		3.6	V
SBU Switch					
V_{SBU}	V_{SBU1} to GND, V_{SBU2} to GND, V_{SBU1_H} to GND, V_{SBU2_H} to GND,	0		4.0	V
CC Switch					
V_{VICC}	V_{CCx} , to GND	0		5.5	V
V_{VCC_H}	V_{CCx_H} , to GND	0		5.5	V
I_{CCSW}	CC Switch Current			1.25	A
Control Voltage(ENN,ENx)					
V_{IH}	Input Voltage High	1.3			V
V_{IL}	Input Voltage Low			0.5	V
Operating Temperature					
T_A	Ambient Operating Temperature	-40	25	+85	°C

DC Characteristics

VBAT = 2.7 V to 5.5 V or VBUS= 4.0V to 20V, VBAT(Typ.) = 4.3 V or VBUS(Typ.) = 5V, T_A = -40°C to 85°C, and T_A(Typ.) = 25°C, unless otherwise specified.⁽¹⁾

Symbol	Parameter	Condition	Power	T _A =-40°C to +85°C			Unit
				Min.	Typ.	Max.	
I _{CC}	VBAT Supply current		VBAT=4.3V		25		μA
I _{CCZ}	Quiescent current		VBAT=4.3V		5		μA
USB/Audio Common Pins							
I _{OZ}	Off leakage current of Port DP/R and DN/L	DN/L,DP/ R=-3V to 4.0V	VBAT: 2.7V to 5.5V or VBUS: 4V to 20V	-3.0		3.0	μA
I _{OFF}	Power-Off leakage current of Port DP/R and DN/L	DN/L,DP/R=0V to 4.0V	Power off	-3.0		3.0	μA
V _{OV_TRIP}	Input OVP Lockout	Rising edge	VBAT: 2.7V to 5.5V or VBUS: 4V to 20V	4.2	4.5	4.8	V
V _{OV_HYS}	Input OVP Hysteresis				0.3		V
Audio Switch							
I _{ON}	On leakage current of Audio switch	DN/L,DP/R=-3V to 3.0V, DP, DN, R, L= Float	VBAT: 2.7V to 5.5V or VBUS: 4V to 20V	-2.0	0.1	2.0	μA
I _{OFF}	Power-Off Leakage Current on L and R	L, R, = 0V to 3 V	Power off	-1.0		1.0	μA
R _{ON}	Switch On Resistance	I _{SW} = 100 mA, V _{SW} = -3 V to 3 V	VBAT: 2.7V to 5.5V or VBUS: 4V to 20V		0.6		Ω
R _{SHUNT}	Pull down resistor on R/L Pin when Audio switch is off	L=R= 3 V			6	10	14
USB Switch							
I _{ON}	On leakage current of USB switch	DN/L,DP/R=0V to 4.0V, DP, DN, R, L= Float	VBAT: 2.7V to 5.5V or VBUS: 4V to 20V	-3.0	1.0	3.0	μA
I _{OZ}	Off leakage current of Port DP and DN	DN,DP =0V to 4.0V			-3.0		3.0
I _{OFF}	Power-Off Leakage Current on DP and DN	DN,DP =0V to 4.0V	Power off	-3.0		3.0	μA
R _{ON_USB}	USB Switch On Resistance	I _{SW} = 8 mA, V _{SW} = 0.4V	VBAT: 2.7V to 5.5V or VBUS: 4V to 20V		3		Ω
CC Switch							
I _{ON}	On leakage Current of CC switch	V _{sw} from 0V to 3.6V,	VBAT: 2.7V to 5.5V or VBUS: 4V to 20V	-1.5		2.0	μA
R _{ON}	CC Path On Resistance	I _{OUT} =200mA, V _{SW} =5V				300	mΩ
V _{OV_TRIP}	Input OVP Lockout	Rising edge			5.6	5.8	6.1
V _{OV_HYS}	Input OVP Hysteresis				0.3		V
R _d	Dead Battery pull down resistance	350uA on CCx pin	VBAT<2.4V and VBUS < 3.5V	4.08	5.1	6.12	kΩ

Symbol	Parameter	Condition	Power	T _A =-40°C to +85°C			Unit
				Min.	Typ.	Max.	
V _{THR_H}	CCx_H High Threshold under headset detection	EN1=H	VBAT: 2.7V to 5.5V or VBUS: 4V to 20V		1.5		V
V _{THR_L}	CCx_HLowThreshold under headset detection	EN1=H			1.2		V
SBU Common pins							
I _{OZ}	Off leakage current of Port SBUx	SBUx= 0V to 4V	VBAT: 2.7V to 5.5V or VBUS: 4V to 20V	-3.0		3.0	μA
I _{OFF}	Power-Off leakage current of Port SBUx	SBUx= 0V to 4V	Power off	-3.0		3.0	μA
V _{OV_TRIP}	Input OVP Lockout	Rising edge	VBAT: 2.7V to 5.5V or VBUS: 4V to 20V	4.2	4.5	4.8	V
V _{OV_HYS}	Input OVP Hysteresis				0.3		V
MIC Switch							
I _{ON}	On leakage current of MIC switch	SBUx= 0V to 3.6V, MIC is floating	VBAT: 2.7V to 5.5V or VBUS: 4V to 20V	-3.0		3.0	μA
I _{OZ}	Off leakage current on MIC	MIC=0V to 3.6V		-1.0		1.0	μA
I _{OFF}	Power Off leakage current on MIC	MIC=0V to 3.6V	Power off	-1.0		1.0	μA
R _{ON}	MIC switch On Resistance	MIC=0V to 3.6V, I _{sw} =30mA	VBAT: 2.7V to 5.5V or VBUS: 4V to 20V		2		Ω
GND_M Switch							
I _{OZ}	Off leakage on GND_M	GND_M=0V to 3.6V	VBAT: 2.7V to 5.5V or VBUS: 4V to 20V	-2.0		2.0	μA
I _{OFF}	Power Off leakage current on GND_M	GND_M =0V to 3.6V	Power off	-1.0		1.0	μA
R _{ON}	GND_M Switch On Resistance	I _{sw} =30mA	VBAT: 2.7V to 5.5V or VBUS: 4V to 20V		0.5		Ω
SBU Bypass Switch							
I _{ON}	On leakage current of SBU bypass switch	SBUx= 0V to 4V, SBUx_H is floating	VBAT: 2.7V to 5.5V or VBUS: 4V to 20V	-1.0		2.0	μA
I _{OZ}	Off leakage current on SBUx_H	SBUx_H = 0V to 4V		-1.0		1.0	μA
R _{ON}	SBU bypass Switch On Resistance	SBUx =0V to 3.6V, I _{sw} =50mA				3	Ω
Internal GND Switch							
R _{ON}	Internal GND switch On Resistance	I _{sw} =200mA	VBAT: 2.7V to 5.5V or VBUS: 4V to 20V		75	110 ^[2]	mΩ

Notes:

- Limits over the recommended temperature operating range (T_A = -40°C to +85°C) are correlated by statistical quality.
- Guaranteed by characterization, not production tested

AC Characteristics

VBAT= 2.7 V to 5.5 V or VBUS= 4.0V to 20V, VBAT(Typ.) = 4.3 V or VBUS(Typ.) = 5V, T_A = -40°C to 85°C. T_A (Typ.) = 25°C, unless otherwise specified.

Symbol	Parameter	Condition	Power	T _A =-40°C to +85°C			Unit
				Min.	Typ.	Max.	
Audio Switch							
t _{ON}	Turn On Time ⁽³⁾	DP/R = DN/L = 1.5 V, R _L =50Ω	VBAT: 4.3V or VBUS: 5V		55		μs
t _{OFF}	Turn OFF Time ⁽³⁾	DP/R = DN/L = 1.5 V, R _L =50Ω			2		μs
X _{TALK}	Cross Talk (Adjacent) ⁽³⁾	f = 1 kHz, R _L = 50 Ω, V _{SW} = 1 V _{RMS}			-110		dB
BW	-3 dB Bandwidth ⁽³⁾	R _L = 50 Ω			950		MHz
O _{IRR}	Off Isolation ⁽³⁾	f= 1 kHz, R _L = 50 Ω, C _L = 0 pF, V _{SW} =1 V _{RMS}			-100		dB
THD+N	Total Harmonic Distortion + Noise performance with A- weighting filter ⁽³⁾	R _L =600 Ω, f = 20Hz~20 kHz, V _{SW} = 2 V _{RMS}			-110		dB
		R _L =32 Ω, f = 20Hz~20 kHz, V _{SW} = 1 V _{RMS}			-110		dB
		R _L = 16 Ω, f = 20Hz~20 kHz, V _{SW} = 0.5 V _{RMS}			-108		dB
USB Switch							
t _{ON}	Turn-on time ⁽³⁾	DP/R = DN/L = 1.5 V, R _L =50Ω	VBAT: 4.3V or VBUS: 5V		40		μs
t _{OFF}	Turn-off time ⁽³⁾	DP/R = DN/L = 1.5 V, R _L =50Ω			1		μs
BW	-3dB Bandwidth ⁽³⁾	R _L =50Ω			1		GHz
O _{IRR}	Off Isolation ⁽³⁾ between DP, DN and common node pins	f= 1 kHz, R _L = 50 Ω, C _L = 0 pF, V _{SW} =1 V _{RMS}			-100		dB
t _{OVP}	DP/R and DN/L pins OVP Response Time ⁽³⁾	R _L = 50 Ω, V _{sw} = 3.5V to 5.5 V			0.5	1.5	μs
CC Switch							
t _{ON}	Turn-On Time ⁽³⁾	V _{ICcx} = 5V, R _L = 5k Ω	VBAT: 4.3V or VBUS: 5V		0.5		ms
t _{OFF}	Turn-Off Time ⁽³⁾	V _{ICcx} = 5V, R _L = 5k Ω			3		μs
BW	PD Traffic Bandwidth ⁽³⁾	R _L =50Ω			25		MHz
t _{OVP}	CCx pins OVP Response Time ⁽³⁾	R _L = 25 Ω, C _L =200pF, V _{SW} :4V to 7V			0.6	1	μs
SBUx Bypass Switch							
t _{OVP}	SBUx pins OVP Response Time ⁽³⁾	R _L = 50 Ω, V _{sw} = 3.5V to 5.5 V	VBAT: 4.3V or VBUS: 5V		0.6	1	μs

Symbol	Parameter	Condition	Power	T _A =-40°C to +85°C			Unit
				Min.	Typ.	Max.	
t _{ON}	Turn-On Time ⁽³⁾	I _{sw} on SBU _x =1mA and clamp to 2V, R _L on MIC and SBU _{x_H} =1K Ω, GND _M =100mV, series 50 Ω on GND _M pin	VBAT: 4.3V or VBUS: 5V		12		μs
t _{OFF}	Turn-OFF Time ⁽³⁾				1		
BW	Bandwidth ⁽³⁾			R _L =50Ω		25	
MIC/GND_M/Internal GND Switch							
t _{ON_MIC}	Turn-On Time ⁽³⁾	I _{sw} on SBU _x =1mA and clamp to 2V, R _L on MIC and SBU _{x_H} =1K Ω, GND _M =100mV, series 50 Ω on GND _M pin	VBAT: 4.3V or VBUS: 5V		10		μs
t _{ON_GND_M}					60		
t _{ON_GND}					950		
t _{OFF_MIC}	Turn-OFF Time ⁽³⁾				1		
t _{OFF_GND_M}					1		
t _{OFF_GND}					1		
BW	MIC switch Bandwidth ⁽³⁾	R _L =50Ω		25		MHz	
Interrupt delay							
T _{DELAY_INT}	INT response delay ⁽³⁾	INT pull up by 10k resistor to valid power	VBAT: 4.3V or VBUS: 5V		5		μs
T _{DELAY_INT1}	INT1 response delay ⁽³⁾	INT1 pull up by 10k resistor to valid power			5		

3. Guaranteed by characterization, not production tested

Capacitance

Unless otherwise stated VBAT = 2.7 V to 5.5 V or VBUS= 4.0V to 20V, VBAT(Typ.) = 4.3 V or VBUS(Typ.) = 5V, T_A = -40°C to 85°C, and T_A (Typ.) = 25°C.

Symbol	Parameter	Condition	Power	T _A =- 40°C to +85°C			Unit
				Min.	Typ.	Max.	
C _{ON_USB/Audio}	On Capacitance (Common Port) ⁽⁴⁾	f = 1 MHz, 100 mV _{PK-PK} , 100 mV DC bias	VBAT: 4.3V or VBUS: 5V		7		pF
C _{OFF_USB/Audio}	Off Capacitance (Common Port) ⁽⁴⁾	f = 1 MHz, 100 mV _{PK-PK} , 100 mV DC bias			7		pF
C _{OFF_USB}	Off Capacitance (Non-Common Ports) ⁽⁴⁾	f = 1 MHz, 100 mV _{PK-PK} , 100 mV DC bias Figure 12			2		pF
C _{OFF_SBUx_H}	Off Capacitance (Non-Common Ports) ⁽⁴⁾	f = 1 MHz, 100 mV _{PK-PK} , 100 mV DC bias,			12		pF
C _{OFF_SBUx}	Off Capacitance (Common Ports) ⁽⁴⁾	f = 1 MHz, 100 mV _{PK-PK} , 100 mV DC bias,			140		pF
C _{ON_SBUx}	On Capacitance (Common Port) ⁽⁴⁾	f = 1 MHz, 100 mV _{PK-PK} , 100 mV DC bias,			150		pF
C _{CTRL}	Control Input Pin Capacitance (ENx) ⁽⁴⁾	f = 1 MHz, 100 mV _{PP} , 100 mV DC bias		ENx,ENN		6	

4. Guaranteed by characterization, not production tested

Application Information

Dead Battery

FSA4476 supports dead battery application. When power is not applied to FSA4476 and it is attached to a Source device, then the Source would pull up the CC line connected through the cable. FSA4476 in response would turn on the pull-down that will bring the CC voltage to a range that the Source can detect an attach event and turn on VBUS.

Headset detection

FSA4476 integrates headset unplug detection function by detecting the CC_x_H voltage. The headset detection is only active during audio switch on status(EN1=1). When headset is attached(both CC1_H and CC2_H are Low), the flag signal is sent low to host controller by INT1 (INT1= low). Once either of CC_x_H= High (CC_x_H>1.5V), INT1 will be released to high by external pull up resistor.

Power supply configuration

VBUS	VBAT	Power supply
Invalid	Invalid	Max (VBAT ,VBUS)
Valid	Invalid	VBUS
Invalid	Valid	VBAT
Valid	Valid	VBAT

Test Diagrams

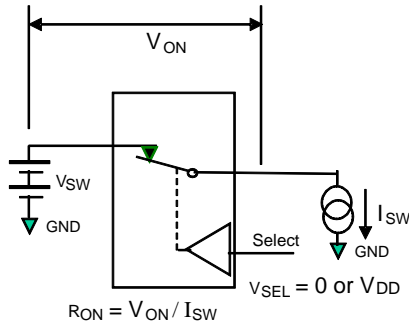

Figure 3. On Resistance

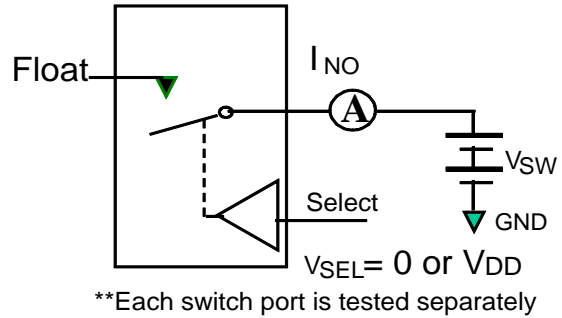

Figure 4. Off Leakage (I_{oz})

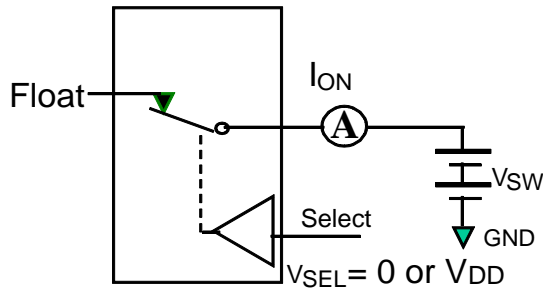

Figure 5. On Leakage

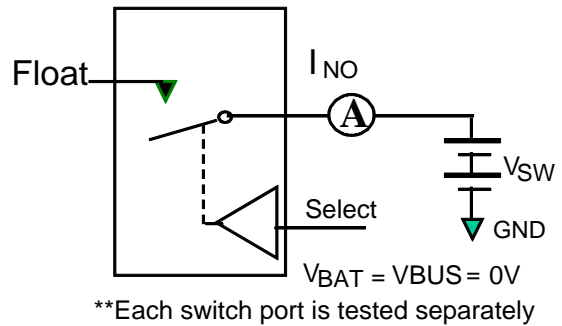

Figure 6. Power Off Leakage (I_{off})

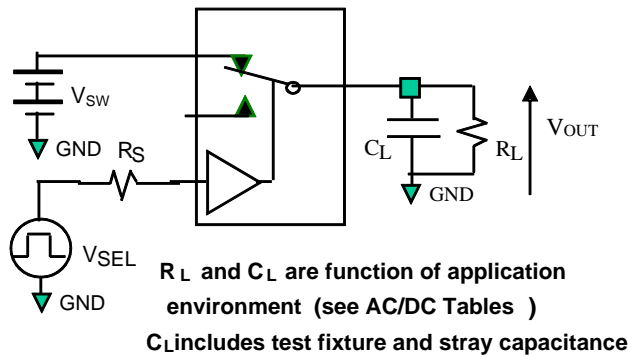

Figure 7. Test Circuit Load

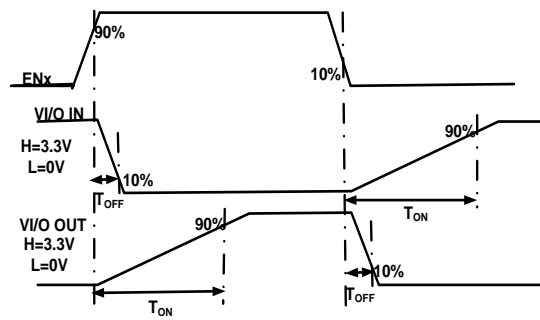

Figure 8. Turn On/Off Waveforms

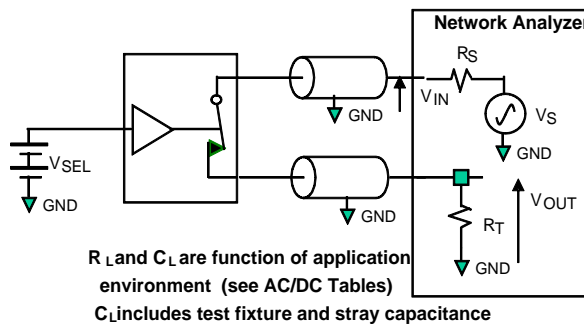

Figure 9. Bandwidth

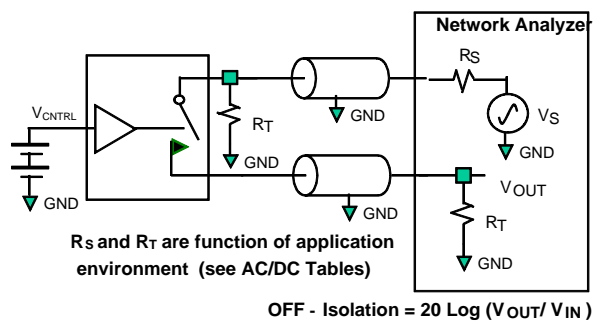

Figure 10. Channel Off Isolation

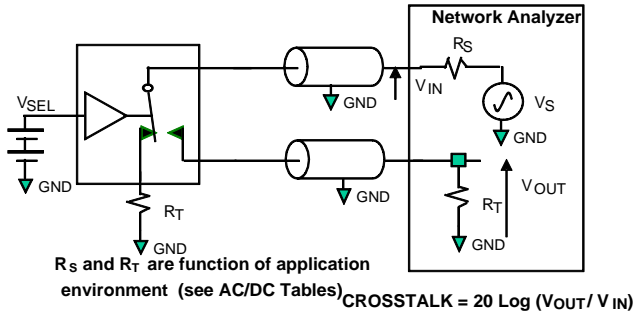

Figure 11. Adjacent Channel Crosstalk

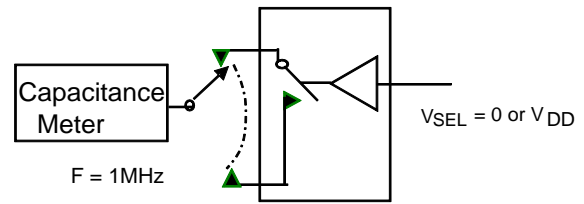

Figure 12. Channel Off Capacitance

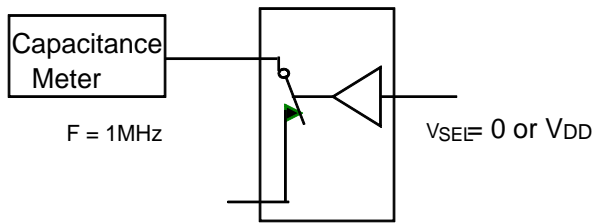

Figure 13. Channel On Capacitance

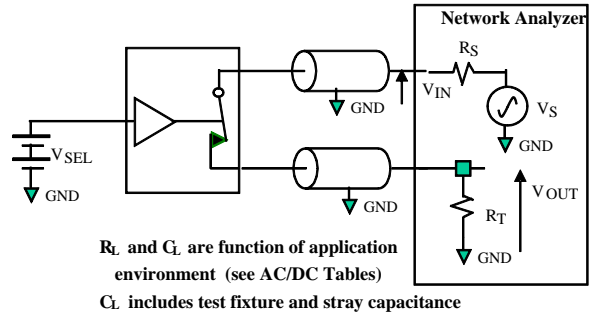

Figure 14. Total Harmonic Distortion (THD+N)

Physical Dimensions

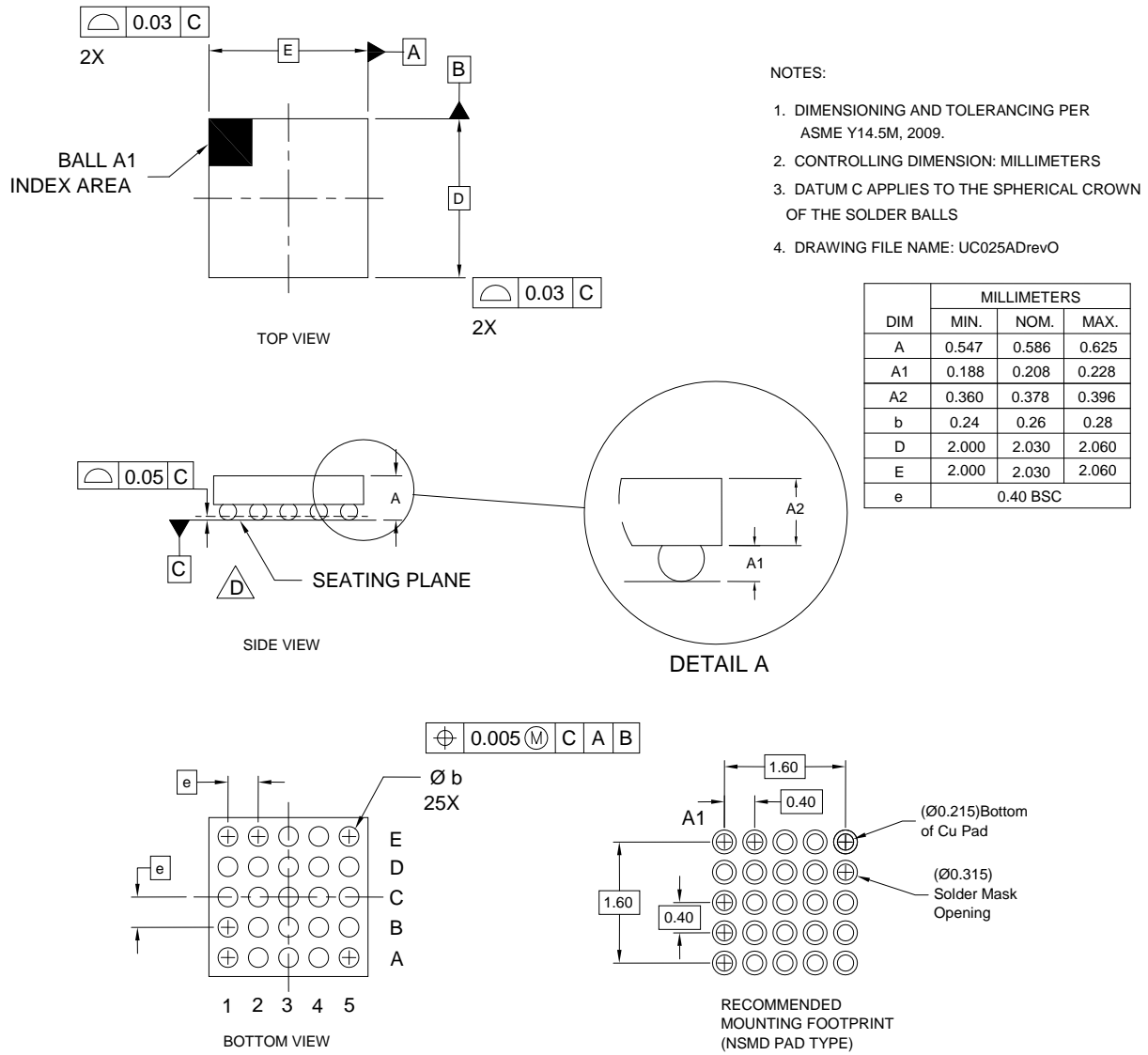

Figure 15. 25-ball WLCSP

ON Semiconductor and the ON Semiconductor logo are trademarks of Semiconductor Components Industries, LLC dba ON Semiconductor or its subsidiaries in the United States and/or other countries. ON Semiconductor owns the rights to a number of patents, trademarks, copyrights, trade secrets, and other intellectual property. A listing of ON Semiconductor's product/patent coverage may be accessed at www.onsemi.com/site/pdf/Patent-Marking.pdf. ON Semiconductor reserves the right to make changes without further notice to any products herein. ON Semiconductor makes no warranty, representation or guarantee regarding the suitability of its products for any particular purpose, nor does ON Semiconductor assume any liability arising out of the application or use of any product or circuit, and specifically disclaims any and all liability, including without limitation special, consequential or incidental damages. Buyer is responsible for its products and applications using ON Semiconductor products, including compliance with all laws, regulations and safety requirements or standards, regardless of any support or applications information provided by ON Semiconductor. "Typical" parameters which may be provided in ON Semiconductor data sheets and/or specifications can and do vary in different applications and actual performance may vary over time. All operating parameters, including "Typicals" must be validated for each customer application by customer's technical experts. ON Semiconductor does not convey any license under its patent rights nor the rights of others. ON Semiconductor products are not designed, intended, or authorized for use as a critical component in life support systems or any FDA Class 3 medical devices or medical devices with a same or similar classification in a foreign jurisdiction or any devices intended for implantation in the human body. Should Buyer purchase or use ON Semiconductor products for any such unintended or unauthorized application, Buyer shall indemnify and hold ON Semiconductor and its officers, employees, subsidiaries, affiliates, and distributors harmless against all claims, costs, damages, and expenses, and reasonable attorney fees arising out of, directly or indirectly, any claim of personal injury or death associated with such unintended or unauthorized use, even if such claim alleges that ON Semiconductor was negligent regarding the design or manufacture of the part. ON Semiconductor is an Equal Opportunity/Affirmative Action Employer. This literature is subject to all applicable copyright laws and is not for resale in any manner.

PUBLICATION ORDERING INFORMATION

LITERATURE FULFILLMENT:

Literature Distribution Center for ON Semiconductor
19521 E. 32nd Pkwy, Aurora, Colorado 80011 USA

Phone: 303-675-2175 or 800-344-3860 Toll Free USA/Canada

Fax: 303-675-2176 or 800-344-3867 Toll Free USA/Canada

Email: orderlit@onsemi.com

N. American Technical Support: 800-282-9855 Toll Free
USA/Canada.

Europe, Middle East and Africa Technical Support:
Phone: 421 33 790 2910

Japan Customer Focus Center
Phone: 81-3-5817-1050

ON Semiconductor Website: www.onsemi.com

Order Literature: <http://www.onsemi.com/orderlit>

For additional information, please contact your local
Sales Representative



**Стандарт
Электрон
Связь**

Мы молодая и активно развивающаяся компания в области поставок электронных компонентов. Мы поставляем электронные компоненты отечественного и импортного производства напрямую от производителей и с крупнейших складов мира.

Благодаря сотрудничеству с мировыми поставщиками мы осуществляем комплексные и плановые поставки широчайшего спектра электронных компонентов.

Собственная эффективная логистика и склад в обеспечивает надежную поставку продукции в точно указанные сроки по всей России.

Мы осуществляем техническую поддержку нашим клиентам и предпродажную проверку качества продукции. На все поставляемые продукты мы предоставляем гарантию .

Осуществляем поставки продукции под контролем ВП МО РФ на предприятия военно-промышленного комплекса России , а также работаем в рамках 275 ФЗ с открытием отдельных счетов в уполномоченном банке. Система менеджмента качества компании соответствует требованиям ГОСТ ISO 9001.

Минимальные сроки поставки, гибкие цены, неограниченный ассортимент и индивидуальный подход к клиентам являются основой для выстраивания долгосрочного и эффективного сотрудничества с предприятиями радиоэлектронной промышленности, предприятиями ВПК и научно-исследовательскими институтами России.

С нами вы становитесь еще успешнее!

Наши контакты:

Телефон: +7 812 627 14 35

Электронная почта: sales@st-electron.ru

Адрес: 198099, Санкт-Петербург,
Промышленная ул, дом № 19, литера Н,
помещение 100-Н Офис 331