

IrDA[®] Standard Protocol Stack Controller With Fixed 9600 Baud Communication Rate

Features

- Implements the IrDA[®] standard, including:
 - IrLAP
 - IrLMP
 - IAS
 - TinyTP
 - IrCOMM (9-wire “cooked” service class)
- Provides IrDA standard physical signal layer support including:
 - Bidirectional communication
 - CRC implementation
 - Fixed Data communication rate of 9600 baud
- Includes UART-to-IrDA standard encoder/decoder functionality:
 - Easily interfaces with industry standard UARTs and infrared transceivers
- UART interface for connecting to Data Communications Equipment (DCE) or Data Terminal Equipment (DTE) systems
- Transmit/Receive formats (bit width) supported:
 - 1.63 μ s
- Hardware UART Support:
 - 9.6 kbaud baud rate
 - 29 Byte Data Buffer Size
- Infrared Supported:
 - 9.6 kbaud baud rate
 - 64 Byte Data Packet Size
- Operates as Secondary Device
- Automatic Low Power mode
 - < 60 μ A when no IR activity present (PHACT = L)

CMOS Technology

- Low power, high-speed CMOS technology
- Fully static design
- Low voltage operation
- Industrial temperature range
- Low power consumption
 - < 1 mA @ 3.0V, 7.3728 MHz (typical)

Package Types

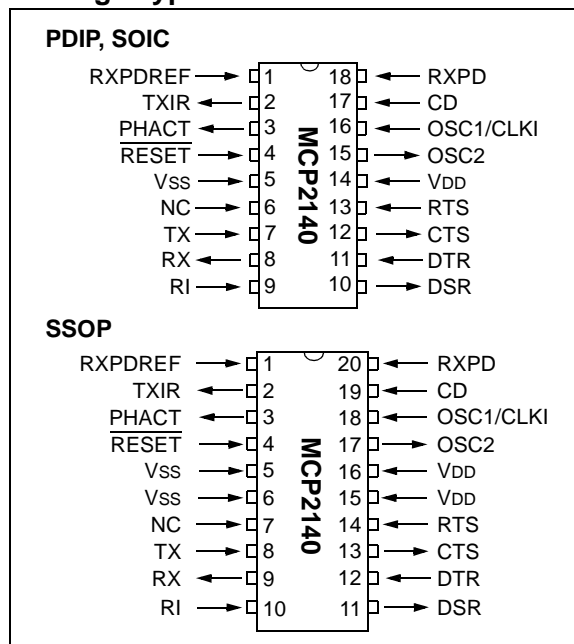

Block Diagram



MCP2140

MCP2140 System Block Diagram

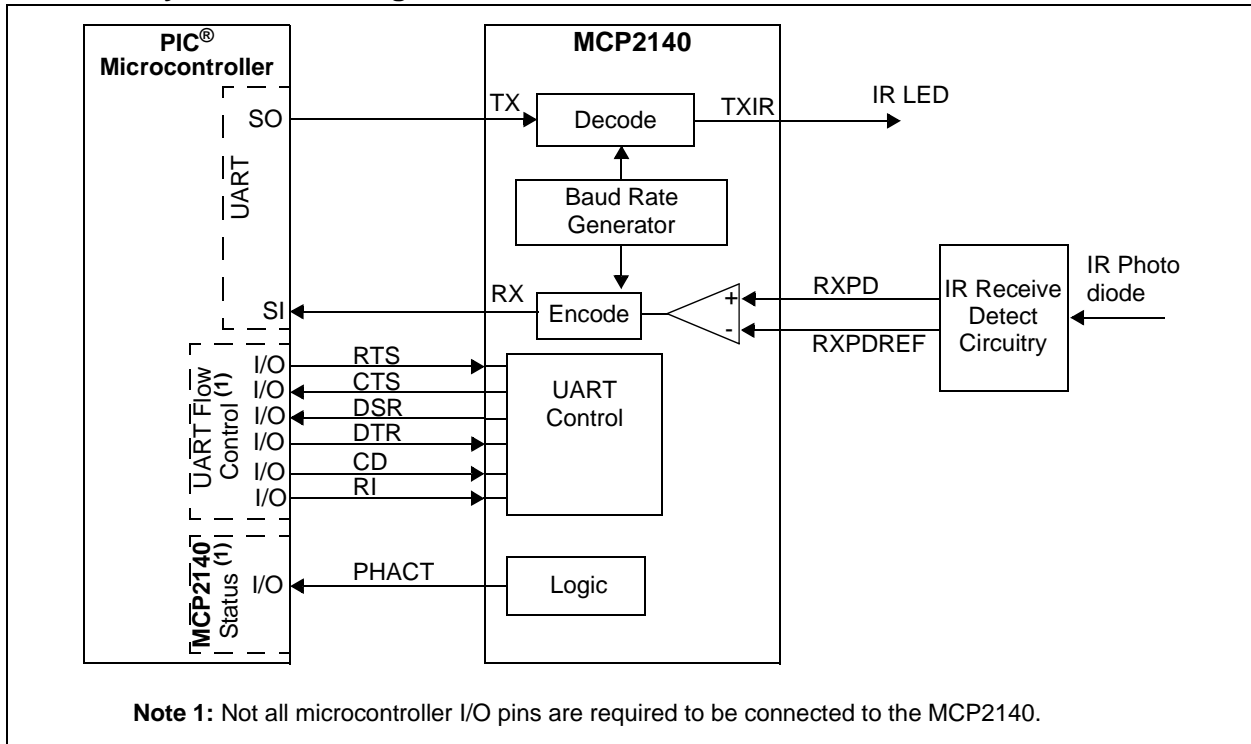

1.0 DEVICE OVERVIEW

The MCP2140 is a cost-effective, low pin count (18-pin), easy-to-use device for implementing IrDA standard wireless connectivity. The MCP2140 provides support for the IrDA standard protocol “stack”, bit encoding/decoding and low cost, discrete IR receiver circuitry.

The serial and IR interface baud rates are fixed at 9600 baud. The serial interface and IR interface baud rates are dependent on the device frequency, but IrDA standard operation requires a device frequency of 7.3728 MHz.

The MCP2140 will specify to the Primary Device the IR baud rate during the Discover phase.

The MCP2140 can operate in Data Communication Equipment (DCE) and Data Terminal Equipment (DTE) applications, and sits between a UART and an infrared optical transceiver.

The MCP2140 encodes an asynchronous serial data stream, converting each data bit to the corresponding infrared (IR) formatted pulse. IR pulses received are decoded and then handled by the protocol handler state machine. The protocol handler sends the appropriate data bytes to the Host Controller in UART-formatted serial data.

The MCP2140 supports “point-to-point” applications, that is, one Primary device and one Secondary device. The MCP2140 operates as a Secondary device and does not support “multi-point” applications.

Sending data using IR light requires some hardware and the use of specialized communication protocols. These protocol and hardware requirements are described, in detail, by the IrDA standard specifications. The encoding/decoding functionality of the MCP2140 is designed to be compatible with the physical layer component of the IrDA standard. This part of the standard is often referred to as “IrPHY”.

The complete IrDA standard specification is available for download from the IrDA website at www.IrDA.org.

1.1 Applications

The MCP2140 Infrared Communications Controller, supporting the IrDA standard, provides embedded system designers the easiest way to implement IrDA standard wireless connectivity. [Figure 1-1](#) shows a typical application block diagram, while [Table 1-2](#) shows the pin definitions.

TABLE 1-1: OVERVIEW OF FEATURES

Features	MCP2140
Serial Communications	UART, IR
Baud Rate Selection	Fixed
Low Power Mode	Yes
Resets (and Delays)	RESET, POR (PWRT and OST)
Packages	18-pin DIP, SOIC, 20-pin SSOP

Infrared communication is a wireless, two-way data connection using infrared light generated by low-cost transceiver signaling technology. This provides reliable communication between two devices.

Infrared technology offers:

- Universal standard for connecting portable computing devices
- Easy, effortless implementation
- Economical alternative to other connectivity solutions
- Reliable, high-speed connections
- Safe to use in any environment (can even be used during air travel)
- Eliminates the hassle of cables
- Allows PCs and other electronic devices (such as PDAs, cell phones, etc.) to communicate with each other
- Enhances mobility by allowing users to easily connect

The MCP2140 allows the easy addition of IrDA standard wireless connectivity to any embedded application that uses serial data. [Figure 1-1](#) shows typical implementation of the MCP2140 in an embedded system.

The IrDA protocol for printer support is not included in the IrCOMM 9-wire “cooked” service class.

MCP2140

FIGURE 1-1: SYSTEM BLOCK DIAGRAM



TABLE 1-2: MCP2140 PIN DESCRIPTION NORMAL OPERATION (DCE)

Pin Name	Pin Number			Pin Type	Buffer Type	Description
	PDIP	SOIC	SSOP			
RXPREF	1	1	1	I	A	IR Receive Photo Detect Diode reference voltage. This voltage will typically be in the range of VDD/2.
TXIR	2	2	2	O	—	Asynchronous transmit to IrDA transceiver.
PHACT	3	3	3	OC	—	Protocol Handler Active. Indicates the state of the MCP2140 Protocol Handler. This output is an open collector, so an external pull-up resistor may be required. 1 = Protocol Handler is in the Discovery or NRM state 0 = Protocol Handler is in NDM state or the MCP2140 is in Low Power mode
RESET	4	4	4	I	ST	Resets the Device
Vss	5	5	5, 6	—	P	Ground reference for logic and I/O pins
NC	6	6	7	I	—	No connect
TX	7	7	8	I	TTL	Asynchronous receive; from Host Controller UART
RX	8	8	9	O	—	Asynchronous transmit; to Host Controller UART
RI	9	9	10	I	TTL	Ring Indicator. The state of this bit is communicated to the IrDA Primary Device. 1 = No Ring Indicate Present 0 = Ring Indicate Present
DSR	10	10	11	O	—	Data Set Ready. Indicates that the MCP2140 has established a valid IrDA link with a Primary Device ⁽¹⁾ . This signal is locally emulated and not related to the DTR bit of the IrDA Primary Device. 1 = An IR link has not been established (No IR Link) 0 = An IR link has been established (IR Link)
DTR	11	11	12	I	TTL	Data Terminal Ready. Indicates that the Embedded device connected to the MCP2140 is ready for IR data. The state of this bit is communicated to the IrDA Primary Device via the IrDA DSR bit carried by IrCOMM. 1 = Embedded device not ready 0 = Embedded device ready
CTS	12	12	13	O	—	Clear to Send. Indicates that the MCP2140 is ready to receive data from the Host Controller. This signal is locally emulated and not related to the CTS/RTS bit of the IrDA Primary Device. 1 = Host Controller should not send data 0 = Host Controller may send data

Legend: TTL = TTL compatible input ST = Schmitt Trigger input with CMOS levels
 A = Analog P = Power
 CMOS = CMOS compatible input OC = Open collector output
 I = Input O = Output

1: The state of the DTR output pin does not reflect the state of the DTR bit of the IrDA Primary Device.

MCP2140

TABLE 1-2: MCP2140 PIN DESCRIPTION NORMAL OPERATION (DCE) (CONTINUED)

Pin Name	Pin Number			Pin Type	Buffer Type	Description
	PDIP	SOIC	SSOP			
RTS	13	13	14	I	TTL	Request to Send. Indicates that a Host Controller is ready to receive data from the MCP2140. This signal is locally emulated and not related to the CTS/RTS bit of the IrDA Primary device. 1 = Host Controller not ready to receive data 0 = Host Controller ready to receive data
VDD	14	14	15, 16	—	P	Positive supply for logic and I/O pins.
OSC2	15	15	17	O	—	Oscillator crystal output.
OSC1/CLKIN	16	16	18	I	CMOS	Oscillator crystal input/external clock source input.
CD	17	17	19	I	ST	Carrier Detect. The state of this bit is communicated to the IrDA Primary device via the IrDA CD bit. 1 = No Carrier Present 0 = Carrier Present
RXPD	18	18	20	I	A	IR RX Photo Detect Diode input. This input signal is required to be a pulse to indicate an IR bit. When the amplitude of the signal crosses the amplitude threshold set by the RXPDPREF pin, the IR bit is detected. The pulse has minimum and maximum requirements as specified in Parameter IR131A .

Legend: TTL = TTL compatible input ST = Schmitt Trigger input with CMOS levels
 A = Analog P = Power
 CMOS = CMOS compatible input OC = Open collector output
 I = Input O = Output

1: The state of the DTR output pin does not reflect the state of the DTR bit of the IrDA Primary Device.

2.0 DEVICE OPERATION

The MCP2140 serial interface and IR baud rates are fixed at 9600 baud, given a 7.3728 MHz device clock.

2.1 Power-Up

Any time the device is powered up (Parameter D003), the Power-Up Timer delay (Parameter 33) occurs, followed by an Oscillator Start-up Timer (OST) delay (Parameter 32). Once these delays complete, communication with the device may be initiated. This communication is from both the infrared transceiver's side and the controller's UART interface.

2.2 Device Reset

The MCP2140 is forced into the reset state when the **RESET** pin is in the low state. Once the **RESET** pin is brought to a high state, the Device Reset sequence occurs. Once the sequence completes, functional operation begins.

2.3 Device Clocks

The MCP2140 requires a clock source to operate. This clock source is used to establish the device timing, including the device "Bit Clock".

2.3.1 CLOCK SOURCE

The clock source can be supplied by one of the following:

- Crystal
- Resonator
- External clock

The frequency of this clock source must be 7.3728 MHz (electrical specification Parameter 1A) for device communication at 9600 baud.

2.3.1.1 Crystal Oscillator / Ceramic Resonators

A crystal or ceramic resonator can be connected to the OSC1 and OSC2 pins to establish oscillation (Figure 2-1). The MCP2140 oscillator design requires the use of a parallel-cut crystal. Use of a series of cut crystals may give a frequency outside of the crystal manufacturers specifications.

FIGURE 2-1: CRYSTAL OPERATION (CERAMIC RESONATOR)

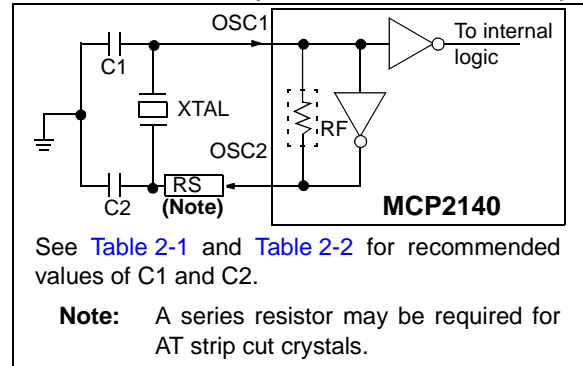

TABLE 2-1: CAPACITOR SELECTION FOR CERAMIC RESONATORS

Freq	OSC1 (C1)	OSC2 (C2)
7.3728 MHz	10 - 22 pF	10 - 22 pF

Note: Higher capacitance increases the stability of the oscillator, but also increases the start-up time. These values are for design guidance only. Since each resonator has its own characteristics, the user should consult the resonator manufacturer for appropriate values of external components.

TABLE 2-2: CAPACITOR SELECTION FOR CRYSTAL OSCILLATOR

Freq	OSC1 (C1)	OSC2 (C2)
7.3728 MHz	15 - 30 pF	15 - 30 pF

Note: Higher capacitance increases the stability of the oscillator but also increases the start-up time. These values are for design guidance only. RS may be required to avoid overdriving crystals with low drive level specification. Since each crystal has its own characteristics, the user should consult the crystal manufacturer for appropriate values of external components.

MCP2140

2.3.1.2 External Clock

For applications where a clock is already available elsewhere, users may directly drive the MCP2140 provided that this external clock source meets the AC/DC timing requirements listed in [Section 4.3, "Timing Diagrams and Specifications"](#). [Figure 2-2](#) shows how an external clock circuit should be configured.

FIGURE 2-2: EXTERNAL CLOCK



2.3.2 BIT CLOCK

The device crystal is used to derive the communication bit clock (BITCLK). There are 16 BITCLKs for each bit time. The BITCLKs are used for the generation of the start bit and the eight data bits. The stop bit uses the BITCLK when the data is transmitted (not for reception).

This clock is a fixed-frequency and has minimal variation in frequency (specified by the crystal manufacturer).

2.4 Host UART Interface

The Host UART interface communicates with the Host Controller. This interface has eight signals associated with it: TX, RX, RTS, CTS, DSR, DTR, CD and RI. Several of these signals are locally generated (not passed over the IR interface). The Host UART is a half-duplex interface, meaning that the system is either transmitting or receiving, but not both simultaneously.

Note 1: The MCP2140 generates several non-data signals locally.

2: The MCP2140 emulates a 3-wire serial connection (TXD, RXD and GND). The transceiver's Transmit Data (TXD), Receive Data (RXD) signals, and the state of the CD, RI and DTR input pins are carried back and forth to the Primary device.

3: The RTS and CTS signals are local emulations.

2.4.1 BAUD RATE

The baud rate for the MCP2140 serial port (the TX and RX pins) is fixed at 9600 baud when the device frequency is 7.3728 MHz.

2.4.2 TRANSMITTING

When the controller sends serial data to the MCP2140, the controller's baud rate is required to match the baud rate of the MCP2140's serial port.

2.4.3 RECEIVING

When the controller receives serial data from the MCP2140, the controller's baud rate is required to match the baud rate of the MCP2140's serial port.

2.4.4 HARDWARE HANDSHAKING

There are three Host UART signals used to control the handshaking operation between the Host Controller and the MCP2140. They are:

- DSR
- RTS
- CTS

2.4.4.1 DSR

The DSR signal is used to indicate that a link has been established between the MCP2140 and the Primary Device. Please refer to Section 2.14, "How Devices Connect", for information on how devices connect.

2.4.4.2 RTS

The RTS signal indicates to the MCP2140 that the Host Controller is ready to receive serial data. Once an IR data packet has been received, the RTS signal will be low for the received data to be transferred to the Host Controller. If the RTS signal remains high, an IR link timeout will occur and the MCP2140 will disconnect from the Primary Device.

2.4.4.3 CTS

The MCP2140 generates the CTS signal locally due to buffer limitations.

The MCP2140 uses a 64-byte buffer for incoming data from the IR Host. Another 29-byte buffer is provided to buffer data from the UART serial port. The MCP2140 can handle IR data and Host UART serial port data simultaneously. A hardware handshaking pin (CTS) is provided to inhibit the Host Controller from sending serial data when the Host UART buffer is not available (Figure 2-3). Figure 2-4 shows a flow chart for Host UART flow control using the CTS signal.

Note: When the CTS output signal goes high, the UART FIFO will store up to 6 bytes. This is to allow devices that have a slow response time to a change on the CTS signal time to stop sending additional data (such as a modem).

FIGURE 2-3: HOST UART CTS SIGNAL AND THE RECEIVE BUFFER



MCP2140

FIGURE 2-4: HOST UART CTS FLOW CONTROL FLOWCHART



2.5 Encoder/Decoder

The encoder converts the UART format data into the IrDA Standard format data and the decoder converts IrDA Standard format data into UART format data.

2.5.1 ENCODER (MODULATION)

The data that the MCP2140 UART received (on the TX pin) that needs to be transmitted (on the TXIR pin) will need to be modulated. This modulated signal drives the IR transceiver module. Figure 2-5 shows the encoding of the modulated signal.

Each bit time is comprised of 16-bit clocks. If the value to be transmitted (as determined by the TX pin) is a logic-low, the TXIR pin will output a low level for 7-bit clock cycles, a logic high level for 3-bit clock cycles or a minimum of 1.6 μsec (see [Parameter IR121](#)). The remaining 6-bit clock cycles will be low. If the value to transmit is a logic-high, the TXIR pin will output a low level for the entire 16-bit clock cycles.

Note: The signal on the TXIR pin does not actually line up in time with the bit value that was transmitted on the TX pin, as shown in Figure 2-5. The TX bit value is shown to represent the value to be transmitted on the TXIR pin.

FIGURE 2-5: ENCODING



MCP2140

2.5.2 DECODER (DEMODULATION)

The modulated signal (data) from the IR transceiver module (on RXIR pin) needs to be demodulated to form the received data (on RX pin). Once demodulation of the data byte occurs, the data that is received is transmitted by the MCP2140 UART (on the RX pin). [Figure 2-6](#) shows the decoding of the modulated signal.

Note: The signal on the RX pin does not actually line up in time with the bit value that was received on the RXIR pin, as shown in [Figure 2-6](#). The RXIR bit value is shown to represent the value to be transmitted on the RX pin.

Each bit time is comprised of 16-bit clocks. If the value to be received is a logic-low, the RXIR pin will be a low level for the first 3-bit clock cycles, or a minimum of 1.6 μ s. The remaining 13-bit clock cycles (or difference up to the 16-bit clock time) will be high. If the value to be received is a logic-high, the RXIR pin will be a high level for the entire 16-bit clock cycles. The level on the RX pin will be in the appropriate state for the entire 16 clock cycles.

2.6 IR Port Baud Rate

The baud rate for the MCP2140 IR port (the TXIR and RXIR pins) is fixed at the default rate of 9600 baud. The Primary device will be informed of this parameter during NDM. The Host UART baud rate and the IR port baud rate are the same.

FIGURE 2-6: DECODING

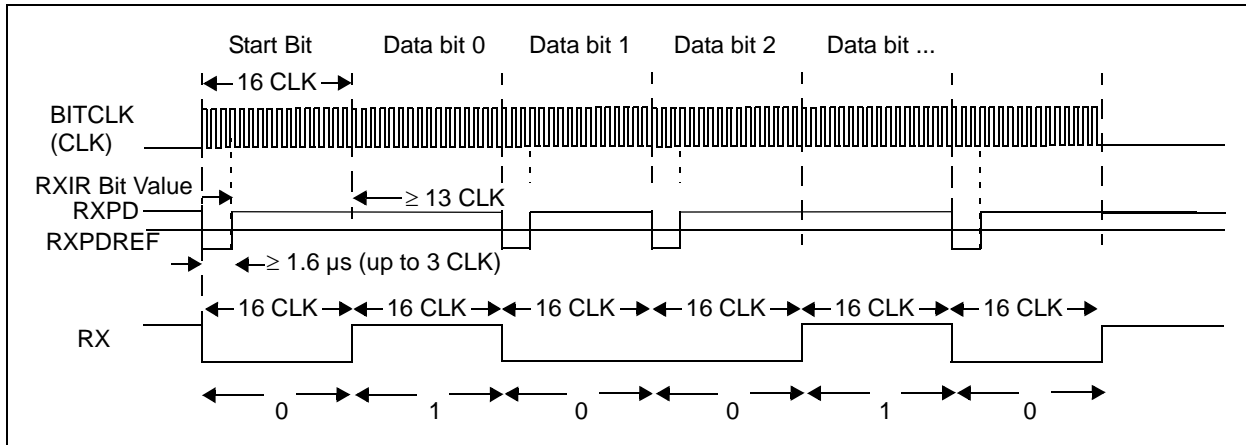

2.7 IrDA DATA PROTOCOLS SUPPORTED BY MCP2140

The MCP2140 supports these required IrDA standard protocols:

- Physical Signaling Layer (PHY)
- Link Access Protocol (IrLAP)
- Link Management Protocol/Information Access Service (IrLMP/IAS)

The MCP2140 also supports some of the optional protocols for IrDA standard data. The optional protocols implemented by the MCP2140 are:

- Tiny TP
- IrCOMM

Figure 2-7 shows the IrDA data protocol stack and those components implemented by the MCP2140.

FIGURE 2-7: IrDA DATA - PROTOCOL STACKS

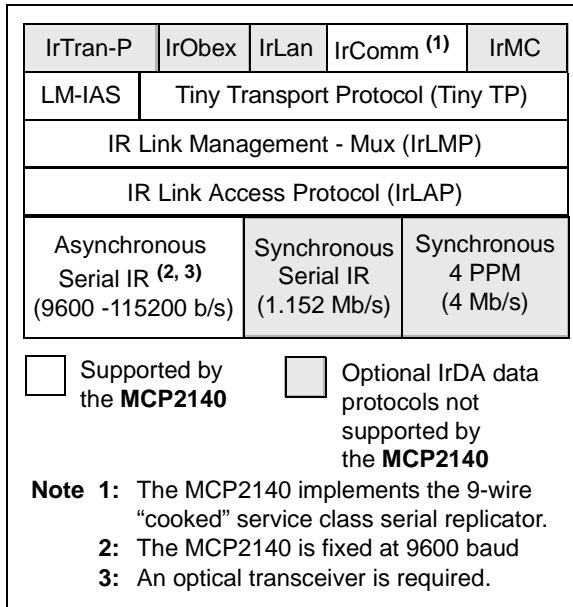

2.7.1 IRCOMM

IrCOMM provides the method to support serial and parallel port emulation. This is useful for legacy COM applications, such as printers and modem devices.

The IrCOMM standard is a syntax that allows the Primary device to consider the Secondary device a serial device. IrCOMM allows for emulation of serial or parallel (printer) connections of various capabilities. The MCP2140 supports the 9-wire "cooked" service class of IrCOMM. Other service classes supported by IrCOMM are shown in Figure 2-8.

The IrDA protocol for printer support is not included in the IrCOMM 9-wire "cooked" service class.

FIGURE 2-8: IRCOMM SERVICE CLASSES



MCP2140

2.8 Minimizing Power

During IR communication between a Primary Device and the MCP2140, the MCP2140 is in an operational mode. In this mode, the MCP2140 consumes the operational current ([Parameter D010](#)).

For many applications, the time that IR communication is occurring is a small percentage of the applications operational time. The ability for the IR controller to be in a low power mode during this time will save on the applications power consumption. The MCP2140 will automatically enter a low power mode once IR activity has stopped and will return to operational mode once IR activity is detected on the RXPDP and RXPDPREF pins.

Another way to minimize system power is to use an I/O pin of the Host Controller to enable power to the IR circuitry

2.8.1 AUTOMATIC LOW POWER MODE

The Automatic Low Power mode allows the system to achieve the lowest possible operating current.

When the IR link has been “closed”, the protocol handler state machine returns to the Normal Disconnect Mode (NDM). During NDM, if no IR activity occurs for about 10 seconds, the device is disabled and enters into Low Power mode. In this mode, the device oscillator is shut down and the PHACT pin will be low ([Parameter D010A](#)).

[Table 2-3](#) shows the MCP2140 current. These are specified in [Parameter D010](#) and [Parameter D010A](#).

TABLE 2-3: DEVICE MAXIMUM OPERATING CURRENT

Mode	Current	Comment
PHACT = H	2.2 mA	IR communications is occurring.
PHACT = L	60 μ A	No IR communications.

Note: Additional system current is from the Receiver/Transmitter circuitry.

2.8.2 RETURNING TO DEVICE OPERATION

The device will exit the Low Power mode when the RXPDP pin voltage crosses the RXPDPREF pin reference voltage.

A device reset will also cause the MCP2140 to exit Low Power mode. After device initialization, if no IR activity occurs for about 10 seconds, the device is disabled and returns into the Low Power mode.

Note: For proper operation, the device oscillator must be within oscillator specification in the time frame specified in [Parameter IR140](#).

2.9 PHACT Signal

The PHACT signal indicates that the MCP2140 Protocol Handler is active. This output pin is an open collector, so when interfacing to the Host Controller, a pull-up resistor is required.

2.10 Buffers and Throughput

The IR data rate of the MCP2140 is fixed at 9.6 kbaud. The actual throughput will be less due to several factors. The most significant factors are under the control of the developer. One factor beyond the control of the designer is the overhead associated with the IrDA standard. A throughput example is shown in Table 2-4.

Figure 2-9 shows the CTS waveform, what the state of the buffers can be and the operation of the Host UART and IR interfaces.

Figure 2-10 shows the screen-capture of a Host Controller transmitting 240 bytes. Data is not transmitted after CTS goes high (so only a maximum of 23 bytes of the 29 byte buffer are utilized). Between data packets, the CTS time can vary, depending on the Primary Device (see blue circled CTS pulse in Figure 2-10).

TABLE 2-4: THROUGHPUT

Bytes Transferred (3)	Bytes/CTS Low	Time (S)	Effective Baud Rate
240	23 (max) (1)	0.810133	2962 (1)
240	29	0.6500	3692 (2)

- Note 1:** Measured from Figure 2-10.
Note 2: Interpolated from Figure 2-10.
Note 3: 10 bits transferred for each byte.

Note: IrDA throughput is based on many factors associated with characteristics of the Primary and Secondary devices. These characteristics may cause your throughput to be more or less than is shown in Table 2-4.

FIGURE 2-9: HOST UART RECEIVE BUFFER AND CTS WAVEFORM

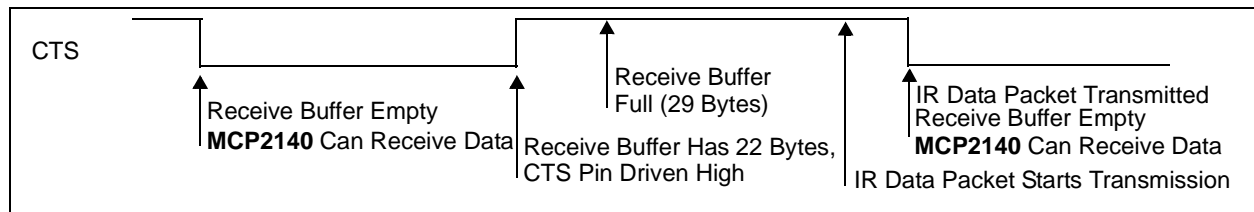
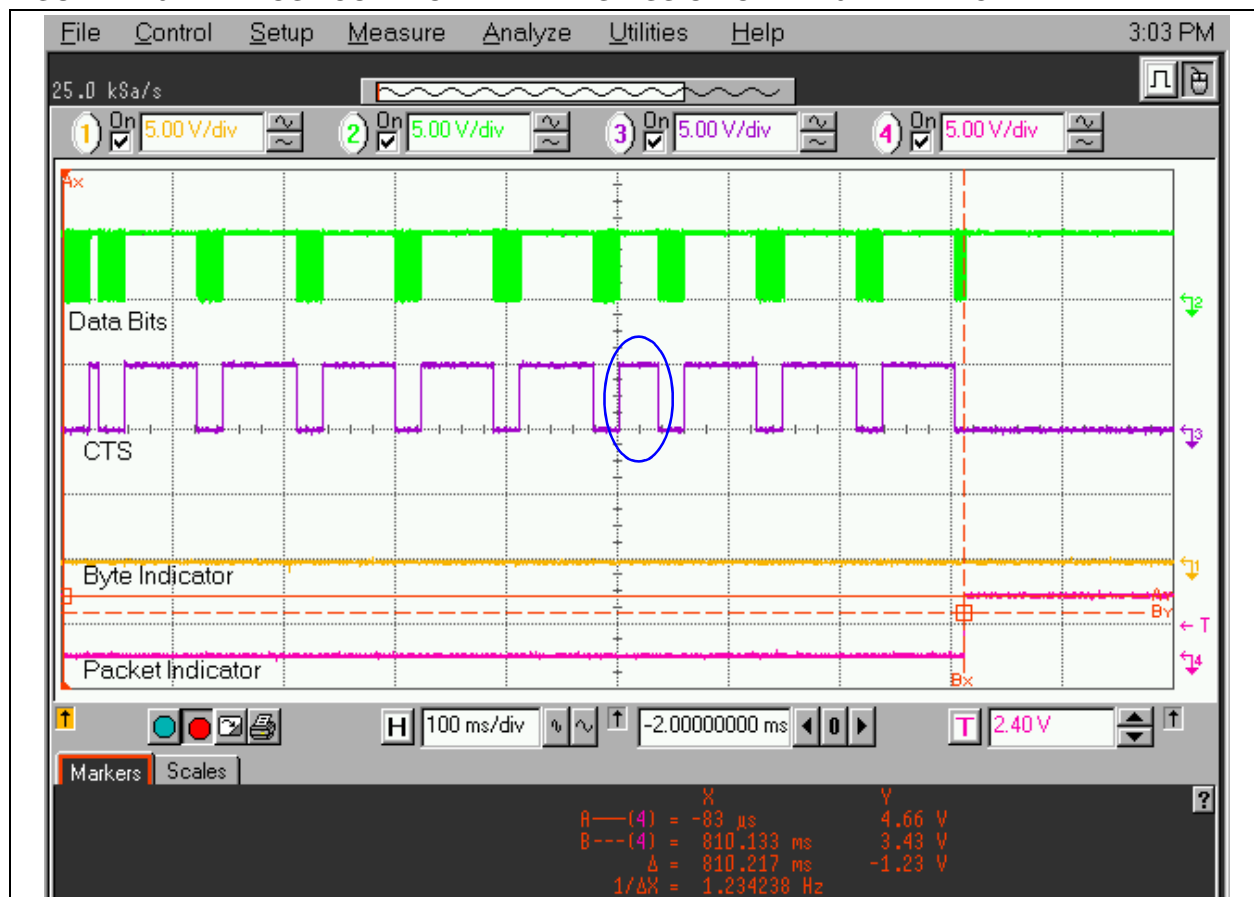

FIGURE 2-10: HOST CONTROLLER TRANSMISSION OF A 240 BYTE PACKET



MCP2140

2.10.1 IMPROVING THROUGHPUT

Actual maximum throughput is dependent on several factors, including:

- Characteristics of the Primary device
- Characteristics of the MCP2140
- IrDA standard protocol overhead

The IrDA standard specifies how the data is passed between the Primary device and Secondary device. In IrCOMM, an additional 8 bytes are used by the protocol for each packet transfer.

The most significant factor in data throughput is how well the data frames are filled. If only 1 byte is sent at a time, the throughput overhead of the IrCOMM protocol is 89% (see [Table 2-5](#)). The best way to maximize throughput is to align the amounts of data with the receive buffer (IR and Host UART) packet size of the MCP2140.

Then there is the delay between when data packets are sent and received. See [Figure 2-10](#) for an example of this delay (look at CTS signal falling edges). In this screen capture, a Palm™ m105 is receiving a 240-byte string of data from the MCP2140. When the CTS signal goes high, the Host Controller stops sending data (23 bytes per CTS low-time). The CTS falling edge to CTS falling edge is approximately 90 ms (typical). This CTS high-time affects the total data throughput. The CTS high-time will be dependant on the characteristics of the Primary device.

TABLE 2-5: IRCOMM OVERHEAD %

MCP2140	Data Packet Size (Bytes)	IrCOMM Overhead (Bytes)	IrCOMM Overhead % ⁽¹⁾	Comment
IR Receive	64	8	11 %	Note 2
	1	8	89 %	
Host UART Receive	29	8	22 %	Note 3
	23	8	26 %	Note 4
	1	8	89 %	

Note 1: Overhead % =
$$\frac{\text{Overhead}}{\text{Overhead} + \text{Data}}$$

- 2:** The maximum number of bytes of the IR Receive buffer.
- 3:** The maximum number of bytes of the Host UART Receive buffer.
- 4:** The CTS signal is driven high at 23 byte.

2.10.1.1 From the Primary Device

The MCP2140 uses a fixed IR Receiver data block size of 64 bytes.

The minimum size frame the Primary device can respond with is 6 bytes.

2.10.1.2 From the MCP2140

The MCP2140 uses a fixed Host UART Receiver data block size of 29 bytes.

2.11 Turnaround Latency

An IR link can be compared to a one-wire data connection. The IR transceiver can transmit or receive, but not both at the same time. A delay of one bit time is recommended between the time a byte is received and another byte is transmitted.

2.12 Device ID

The MCP2140 has a fixed Device ID. This Device ID is "MCP2140 xx", with the xx indicating the silicon revision of the device.

2.13 Optical Interface

The MCP2140 requires an infrared transceiver for the optical interface. This transceiver can be a single-chip solution (integrated) or be implemented with discrete devices.

2.13.1 DISCRETE TRANSCEIVER SOLUTION

The MCP2140 was designed to use a discrete implementation that allows the lowest system power consumption as well as a low cost implementation.

Figure 2-12 shows a typical discrete optical transceiver circuit.

FIGURE 2-11: CIRCUIT FOR A DISCRETE OPTICAL TRANSCEIVER

This figure will be available in Revision B of the MCP2140 data sheet. Please contact the Microchip factory via email (tech.support@microchip.com) for additional information.

Care must be taken in the design and layout of the photo-detect circuit, due to the small signals that are being detected and their sensitivity to noise.

2.13.2 INTEGRATED TRANSCEIVER

The MCP2140 was designed to use a discrete implementation that allows the lowest system power consumption and a low cost implementation (see Section 2.13.1, “Discrete Transceiver Solution”). It is possible to use an integrated optical transceiver solution, with the addition of four components. Two components are required to condition the input signal to ensure that the RXIR pulse width is not greater than 1.5 μs (see Parameter IR131A). The other two components are required to set the RXIR signal trip point (typically $V_{DD}/2$). Figure 2-12 shows an example MCP2140 optical transceiver circuit, using a Vishay®/Temic TFDS4500.

FIGURE 2-12: CIRCUIT FOR AN INTEGRATED OPTICAL TRANSCEIVER



Table 2-6 shows a list of common manufacturers of integrated optical transceivers.

MCP2140

2.14 How The MCP2140 Connects

When two devices, implementing the IrDA standard feature, establish a connection using the IrCOMM protocol, the process is analogous to connecting two devices with serial ports using a cable. This is referred to as a “point-to-point” connection. This connection is limited to half-duplex operation because the IR transceiver cannot transmit and receive at the same time. The purpose of the IrDA standard protocol is to allow this half-duplex link to emulate, as much as possible, a full-duplex connection. In general, this is done by dividing the data into “packets”, or groups of data. These packets can be sent back and forth, when needed, without risk of collision. The rules of how and when these packets are sent constitute the IrDA standard protocol. The MCP2140 supports elements of this IrDA standard protocol to communicate with other IrDA standard compatible devices.

When a wired connection is used, the assumption is made that both sides have the same communications parameters and features. A wired connection has no need to identify the other connector because it is assumed that the connectors are properly connected. According to the IrDA standard, a connection process has been defined to identify other IrDA standard compatible devices and establish a communication link. There are three steps that these two devices go through to make this connection. They are:

- Normal Disconnect Mode (NDM)
- Discovery Mode
- Normal Connect Mode (NCM)

Figure 2-13 shows the connection sequence.

2.14.1 NORMAL DISCONNECT MODE (NDM)

When two IrDA standard compatible devices come into range, they must first recognize each other. The basis of this process is that one device has some task to accomplish and the other device has a resource needed to accomplish this task. One device is referred to as a Primary device while the other is referred to as a Secondary device. The distinction between Primary device and Secondary device is important because it is the responsibility of the Primary device to provide the mechanism to recognize other devices. So the Primary device must first poll for nearby IrDA standard compatible devices and, during this polling, the default baud rate of 9600 baud is used by both devices.

For example, if you want to print from an IrDA-equipped laptop to an IrDA-equipped printer, utilizing the IrDA standard feature, you would first bring your laptop in range of the printer. In this case, the laptop is the one that has something to do and the printer has the resource to do it. Thus, the laptop is called the Primary device and the printer is the Secondary device. Some data-capable cellphones have IrDA standard infrared

ports. If you used such a cell phone with a Personal Digital Assistant (PDA), the PDA that supports the IrDA standard feature would be the Primary device and the cell phone would be the Secondary device.

When a Primary device polls for another device, a nearby Secondary device may respond. When a Secondary device responds, the two devices are defined to be in the Normal Disconnect Mode (NDM) state. NDM is established by the Primary device broadcasting a packet and waiting for a response. These broadcast packets are numbered. Usually, 6 or 8 packets are sent. The first packet is number 0, while the last packet is usually numbered 5 or 7. Once all the packets are sent, the Primary device sends an ID packet, which is not numbered.

The Secondary device waits for these packets and then responds to one of the packets. The packet responds to determine the “timeslot” to be used by the Secondary device. For example, if the Secondary device responds after packet number 2, the Secondary device will use timeslot 2. If the Secondary device responds after packet number 0, the Secondary device will use timeslot 0. This mechanism allows the Primary device to recognize as many nearby devices as there are timeslots. The Primary device will continue to generate timeslots and the Secondary device should continue to respond, even if there’s nothing to do.

Note 1: The MCP2140 can only be used to implement a Secondary device.

2: The MCP2140 supports a system with only one Secondary device having exclusive use of the IrDA standard infrared link (known as “point-to-point” communication).

3: The MCP2140 always responds to packet number 0. This means that the MCP2140 will always use timeslot 0.

4: If another Secondary device is nearby, the Primary device may fail to recognize the MCP2140, or the Primary device may not recognize either of the devices.

During NDM, the MCP2140 handles all responses to the Primary device (Figure 2-13) without any communication with the Host Controller. The Host Controller is inhibited by the CTS signal of the MCP2140 from sending data to the MCP2140.

2.14.2 DISCOVERY MODE

Discovery mode allows the Primary device to determine the capabilities of the MCP2140 (Secondary device). Discovery mode is entered once the MCP2140 (Secondary device) has sent a XID response to the Primary device and the Primary device has completed sending the XIDs and a Broadcast ID. If this sequence is not completed, a Primary and Secondary device can stay in NDM indefinitely.

When the Primary device has something to do, it initiates Discovery, which has two parts. They are:

- Link initialization
- Resource determination

The first step is for the Primary and Secondary devices to determine, and then adjust to, each other's hardware capabilities. These capabilities are parameters like:

- Data rate
- Turnaround time
- Number of packets without a response
- How long to wait before disconnecting

Both the Primary and Secondary devices begin communications at 9600 baud, the default baud rate. The Primary device sends its parameters and the Secondary device responds with its parameters. For example, if the Primary device supports all data rates up to 115.2 kbaud and the Secondary device only supports 9.6 kbaud, the link will be established at 9.6 kbaud.

Note: The MCP2140 is limited to a data rate of 9.6 kbaud.

Once the hardware parameters are established, the Primary device must determine if the Secondary device has the resources it requires. If the Primary device has a job to print, it must know if it's talking to a printer, and not a modem or other device. This determination is made using the Information Access Service (IAS). The job of the Secondary device is to respond to IAS queries made by the Primary device. The Primary device must ask a series of questions like:

- What is the name of your service?
- What is the address of this service?
- What are the capabilities of this device?

When all the Primary device's questions are answered, the Primary device can access the service provided by the Secondary device.

During Discovery mode, the MCP2140 handles all responses to the Primary device (see [Figure 2-13](#)) without any communication with the Host Controller. The Host Controller is inhibited by the CTS signal of the MCP2140 from sending data to the MCP2140.

2.14.3 NORMAL CONNECT MODE (NCM)

Once discovery has been completed, the Primary device and MCP2140 (Secondary device) can freely exchange data.

The MCP2140 uses a hardware handshake to stop the local serial port from sending data when the MCP2140 Host UART Receiving buffer is full..

Note: Data loss will result if this hardware handshake is not observed.

Both the Primary device and the MCP2140 (Secondary device) check to make sure that data packets are received by the other without errors. Even when data is not required to be sent, the Primary and Secondary devices will still exchange packets to ensure that the connection hasn't, unexpectedly, been dropped. When the Primary device has finished, it transmits the "close link" command to the MCP2140 (Secondary device). The MCP2140 will confirm the "close link" command and both the Primary device and the MCP2140 (Secondary device) will revert to the NDM state.

Note: If the NCM mode is unexpectedly terminated for any reason (including the Primary device not issuing a close link command), the MCP2140 will revert to the NDM state approximately 10 seconds after the last frame has been received.

It is the responsibility of the Host Controller program to understand the meaning of the data received and how the program should respond to it. It's just as if the data were being received by the Host Controller from a UART.

2.14.3.1 Primary Device Notification

The MCP2140 identifies itself to the Primary device as a modem.

Note: The MCP2140 identifies itself as a modem to ensure that it is identified as a serial device with a limited amount of memory.

However, the MCP2140 is not a modem, and the non-data circuits are not handled in a modem fashion.

MCP2140

FIGURE 2-13: HIGH LEVEL MCP2140 CONNECTION SEQUENCE



2.15 References

The IrDA Standards download page can be found at:

<http://www.irda.org/standards/specifications>

Some common manufacturers of optical transceivers are shown in [Table 2-6](#).

TABLE 2-6: COMMON OPTICAL TRANSCEIVER MANUFACTURERS

Company	Company Web Site Address
Sharp®	www.sharpsma.com
Infineon®	www.infineon.com
Agilent®	www.agilent.com
Vishay®/Temic	www.vishay.com
Rohm	www.rohm.com

MCP2140

NOTES:

3.0 DEVELOPMENT TOOLS

An MCP2140 Demo/Development board is planned.

Please check with the Microchip Technology Inc. web site (www.microchip.com) or your local Microchip sales office for product availability.

MCP2140

NOTES:

4.0 ELECTRICAL CHARACTERISTICS

Absolute Maximum Ratings†

Ambient Temperature under bias	-40°C to +125°C
Storage Temperature	-65°C to +150°C
Voltage on VDD with respect to VSS	-0.3V to +7.5V
Voltage on RESET with respect to VSS	-0.3V to +14V
Voltage on all other pins with respect to VSS	-0.3V to (VDD + 0.3V)
Total Power Dissipation ⁽¹⁾	1W
Max. Current out of VSS pin	300 mA
Max. Current into VDD pin	250 mA
Input Clamp Current, I _{IK} (V _I < 0 or V _I > VDD)	±20 mA
Output Clamp Current, I _{OK} (V _O < 0 or V _O > VDD).....	±20 mA
Max. Output Current sunk by any Output pin.....	25 mA
Max. Output Current sourced by any Output pin.....	25 mA

Note 1: Power Dissipation is calculated as follows: $P_{DIS} = V_{DD} \times \{I_{DD} - \sum I_{OH}\} + \sum \{(V_{DD}-V_{OH}) \times I_{OH}\} + \sum (V_{OL} \times I_{OL})$

†**NOTICE:** Stresses above those listed under “Maximum ratings” may cause permanent damage to the device. This is a stress rating only and functional operation of the device at those or any other conditions above those indicated in the operational listings of this specification is not implied. Exposure to maximum rating conditions for extended periods may affect device reliability.

MCP2140

FIGURE 4-1: VOLTAGE-FREQUENCY GRAPH, $-40^{\circ}\text{C} \leq T_A \leq +85^{\circ}\text{C}$



4.1 DC Characteristics

DC Specifications			Electrical Characteristics: Standard Operating Conditions (unless otherwise specified) Operating Temperature: $-40^{\circ}\text{C} \leq T_A \leq +85^{\circ}\text{C}$ (industrial)				
Param. No.	Sym	Characteristic	Min	Typ ⁽¹⁾	Max	Units	Conditions
D001	VDD	Supply Voltage	3.0	—	5.5	V	See Figure 4-1
D002	VDR	RAM Data Retention Voltage ⁽²⁾	2.0	—	—	V	Device Oscillator/Clock stopped
D003	VPOR	VDD Start Voltage to ensure Power-on Reset	—	VSS	—	V	
D004	SVDD	VDD Rise Rate to ensure Power-on Reset	0.05	—	—	V/ms	
D010 D010A	IDD	Supply Current ^(3, 4)	—	—	2.2	mA	VDD = 3.0V, PHACT = H
			—	25	60	μA	VDD = 3.0V, PHACT = L

Note 1: Data in the Typical ("Typ") column is based on characterization results at 25°C. This data is for design guidance only and is not tested.

2: This is the limit to which VDD can be lowered without losing RAM data.

3: When the device is in IR communication (PHACT pin is high), supply current is mainly a function of the operating voltage and frequency. Pin loading, pin rate and temperature have an impact on the current consumption. The test conditions for all IDD measurements are made when device is:

OSC1 = external square wave, from rail-to-rail; all input pins pulled to VSS, RXIR = VDD, $\overline{\text{RESET}} = \text{VDD}$;

4: When the device is in low power mode (PHACT pin is low), current is measured with all input pins tied to VDD or VSS and the output pins driving a high or low level into infinite impedance.

MCP2140

4.1 DC Characteristics (Continued)

DC Specifications			Electrical Characteristics: Standard Operating Conditions (unless otherwise specified) Operating temperature: $-40^{\circ}\text{C} \leq T_A \leq +85^{\circ}\text{C}$ (industrial) Operating voltage V_{DD} range as described in DC spec Section 4.1 .				
Param No.	Sym	Characteristic	Min	Typ	Max	Units	Conditions
D030 D030A D032 D033	V_{IL}	Input Low Voltage Input pins with TTL buffer (TX, RI, DTR, RTS, and CD) $\overline{\text{RESET}}$ OSC1	V_{SS} V_{SS} V_{SS} V_{SS}	— — — —	0.8V 0.15 V_{DD} 0.2 V_{DD} 0.3 V_{DD}	V V V V	$4.5\text{V} \leq V_{DD} \leq 5.5\text{V}$ otherwise
D040 D040A D042 D043	V_{IH}	Input High Voltage Input pins with TTL buffer (TX, RI, DTR, RTS, and CD) $\overline{\text{RESET}}$ OSC1	2.0 0.25 V_{DD} + 0.8 0.8 V_{DD} 0.7 V_{DD}	— — — — —	V_{DD} V_{DD} V_{DD} V_{DD} V_{DD}	V V V V V	$4.5\text{V} \leq V_{DD} \leq 5.5\text{V}$ otherwise
D060 D061 D063	I_{IL}	Input Leakage Current (Notes 1, 2) Input pins $\overline{\text{RESET}}$ OSC1	— — —	— — —	± 1 ± 5 ± 5	μA μA μA	$V_{SS} \leq V_{PIN} \leq V_{DD}$, pin at high-impedance. $V_{SS} \leq V_{PIN} \leq V_{DD}$ $V_{SS} \leq V_{PIN} \leq V_{DD}$
D080 D083	V_{OL}	Output Low Voltage TXIR, RX, DSR, and CTS pins OSC2	— —	— —	0.6 0.6	V V	$I_{OL} = 8.5\text{ mA}$, $V_{DD} = 4.5\text{V}$ $I_{OL} = 1.6\text{ mA}$, $V_{DD} = 4.5\text{V}$
D090 D092	V_{OH}	Output High Voltage (Note 2) TXIR, RX, DSR, and CTS pins OSC2	$V_{DD} - 0.7$ $V_{DD} - 0.7$	— —	— —	V V	$I_{OH} = -3.0\text{ mA}$, $V_{DD} = 4.5\text{V}$ $I_{OH} = -1.3\text{ mA}$, $V_{DD} = 4.5\text{V}$
D100 D101	C_{osc2} C_{io}	Capacitive Loading Specs on Output Pins OSC2 pin All Input or Output pins	— —	— —	15 50	pF pF	When external clock is used to drive OSC1.

Note 1: The leakage current on the $\overline{\text{RESET}}$ pin is strongly dependent on the applied voltage level. The specified levels represent normal operating conditions. Higher leakage current may be measured at different input voltages.

2: Negative current is defined as coming out of the pin.

4.2 Timing Parameter Symbology and Load Conditions

The timing parameter symbols have been created following one of the following formats:

4.2.1 TIMING CONDITIONS

The temperature and voltages specified in [Table 4-2](#) apply to all timing specifications, unless otherwise noted. [Figure 4-2](#) specifies the load conditions for the timing specifications.

TABLE 4-1: SYMBOLOGY

1. TppS2ppS		2. TppS	
T		T	
F	Frequency		
E	Error		
Lowercase letters (pp) and their meanings:			
pp			
io	Input or Output pin	osc	Oscillator
rx	Receive	tx	Transmit
bitclk	RX/TX BITCLK	RST	Reset
drt	Device Reset Timer		
Uppercase letters and their meanings:			
S			
F	Fall	P	Period
H	High	R	Rise
I	Invalid (high-impedance)	V	Valid
L	Low	Z	High-impedance

TABLE 4-2: AC TEMPERATURE AND VOLTAGE SPECIFICATIONS

AC Specifications	Electrical Characteristics:
	Standard Operating Conditions (unless otherwise stated):
	Operating temperature: $-40^{\circ}\text{C} \leq T_A \leq +85^{\circ}\text{C}$ (industrial)
	Operating voltage V_{DD} range as described in DC spec Section 4.1 .

FIGURE 4-2: LOAD CONDITIONS FOR DEVICE TIMING SPECIFICATIONS



MCP2140

4.3 Timing Diagrams and Specifications

FIGURE 4-3: EXTERNAL CLOCK TIMING



TABLE 4-3: EXTERNAL CLOCK TIMING REQUIREMENTS

AC Specifications			Electrical Characteristics: Standard Operating Conditions (unless otherwise specified): Operating Temperature: $-40^{\circ}\text{C} \leq T_A \leq +85^{\circ}\text{C}$ (industrial) Operating Voltage VDD range is described in Section 4.1				
Param. No.	Sym	Characteristic	Min	Typ ⁽¹⁾	Max	Units	Conditions
1	TOSC	External CLKIN Period ^(2, 3)	90.422 90.422	— —	90.422 —	ns ns	Device Operation Low Power mode (PHACT drive Low)
		Oscillator Period ⁽²⁾	90.422	—	90.422	ns	
1A	FOSC	External CLKIN Frequency ^(2, 3)	7.3728	7.3728	7.3728	MHz	
		Oscillator Frequency ⁽²⁾	7.3728	—	7.3728	MHz	
1B	FERR	Error in Frequency	—	—	± 0.01	%	
1C	ECLK	External Clock Error	—	—	± 0.01	%	
4	TosR, TosF	Clock in (OSC1) Rise or Fall Time	—	—	15	ns	

- Note 1:** Data in the Typical ("Typ") column is at 5V, 25°C unless otherwise stated. These parameters are for design guidance only and are not tested.
- 2:** All specified values are based on oscillator characterization data under standard operating conditions. Exceeding these specified limits may result in unstable oscillator operation and/or higher than expected current consumption. When an external clock input is used, the "max" cycle time limit is "DC" (no clock) for all devices.
- 3:** A duty cycle of no more than 60% (High time/Low time or Low time/High time) is recommended for external clock inputs.

FIGURE 4-4: OUTPUT WAVEFORM



TABLE 4-4: OUTPUT TIMING REQUIREMENTS

AC Specifications			Electrical Characteristics: Standard Operating Conditions (unless otherwise specified): Operating Temperature: $-40^{\circ}\text{C} \leq T_A \leq +85^{\circ}\text{C}$ (industrial) Operating Voltage VDD range is described in Section 4.1				
Param. No.	Sym	Characteristic	Min	Typ ⁽¹⁾	Max	Units	Conditions
20	ToR	RX and TXIR pin rise time ⁽²⁾	—	10	40	ns	
21	ToF	RX and TXIR pin fall time ⁽²⁾	—	10	40	ns	

Note 1: Data in the Typical (“Typ”) column is at 5V, 25°C unless otherwise stated.

2: See [Figure 4-2](#) for loading conditions.

MCP2140

FIGURE 4-5: $\overline{\text{RESET}}$ AND DEVICE RESET TIMING

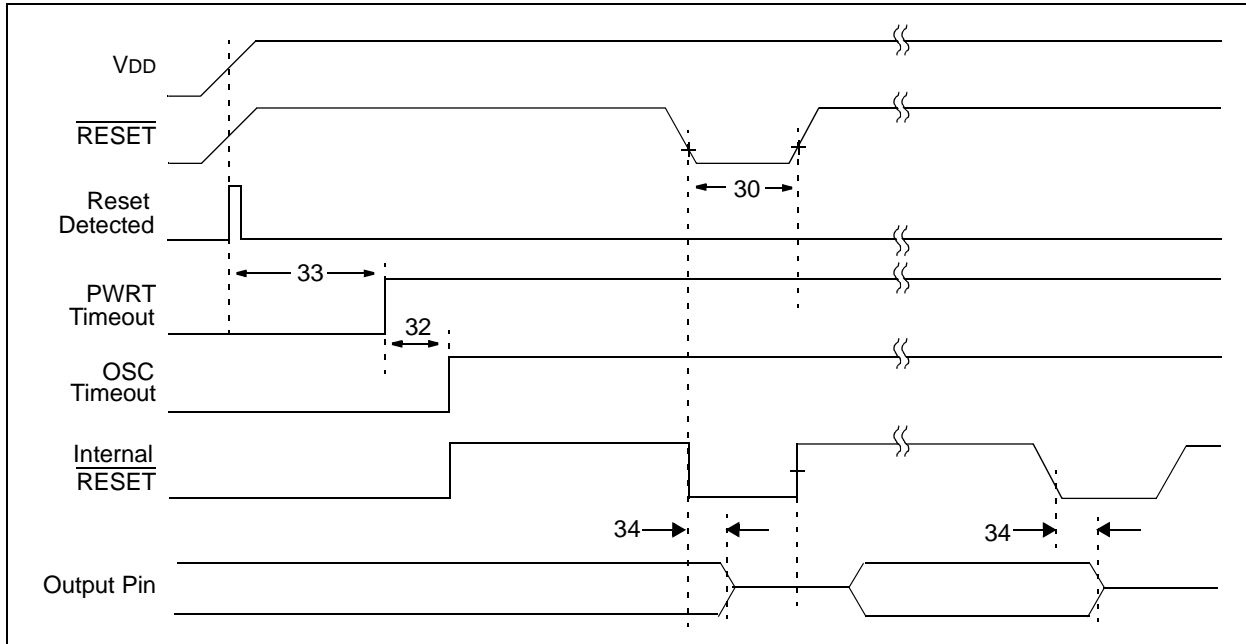

TABLE 4-5: $\overline{\text{RESET}}$ AND DEVICE RESET REQUIREMENTS

AC Specifications			Electrical Characteristics: Standard Operating Conditions (unless otherwise specified): Operating Temperature: $-40^{\circ}\text{C} \leq T_A \leq +85^{\circ}\text{C}$ (industrial) Operating Voltage V_{DD} range is described in Section 4.1				
Param. No.	Sym	Characteristic	Min	Typ ⁽¹⁾	Max	Units	Conditions
30	TRSTL	$\overline{\text{RESET}}$ Pulse Width (low)	2000	—	—	ns	$V_{DD} = 5.0\text{V}$
32	TOST	Oscillator Start-up Timer Period	1024	—	1024	TOSC	
33	TPWRT	Power up Timer Period	28	72	132	ms	$V_{DD} = 5.0\text{V}$
34	TIOZ	Output High-impedance from $\overline{\text{RESET}}$ Low or device Reset	—	—	2	μs	

Note 1: Data in the Typical ("Typ") column is at 5V, 25°C unless otherwise stated.

FIGURE 4-6: UART ASYNCHRONOUS TRANSMISSION WAVEFORM

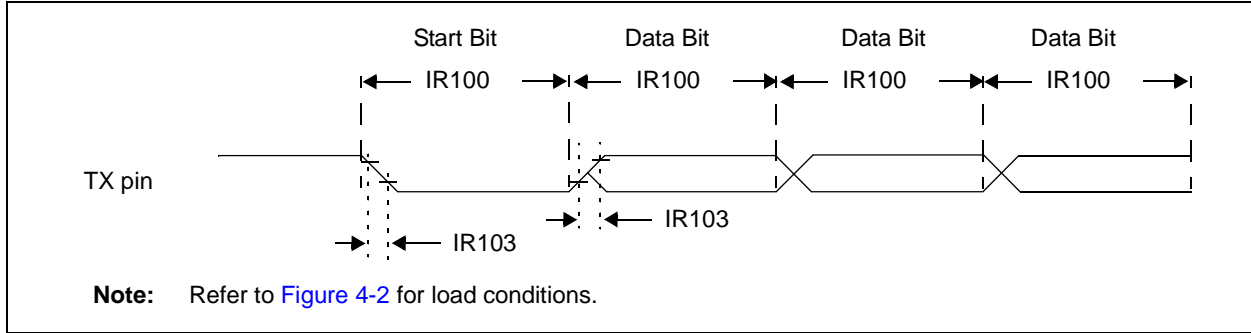

TABLE 4-6: UART ASYNCHRONOUS TRANSMISSION REQUIREMENTS

AC Specifications			Electrical Characteristics: Standard Operating Conditions (unless otherwise specified): Operating Temperature: $-40^{\circ}\text{C} \leq T_A \leq +85^{\circ}\text{C}$ (industrial) Operating Voltage V_{DD} range is described in Section 4.1				
Param. No.	Sym	Characteristic	Min	Typ	Max	Units	Conditions
IR100	T _{TXBIT}	Transmit Baud rate	768	—	768	T _{osc}	BAUD2:BAUD0 = 00
IR101	E _{TXBIT}	Transmit (TX pin) Baud rate Error (into MCP2140)	—	—	±2	%	
IR102	E _{TXIRBIT}	Transmit (TXIR pin) Baud rate Error (out of MCP2140) ⁽¹⁾	—	—	±1	%	
IR103	T _{TXRF}	TX pin rise time and fall time	—	—	25	ns	

Note 1: This error is not additive to IR101 parameter.

MCP2140

FIGURE 4-7: UART ASYNCHRONOUS RECEIVE TIMING



TABLE 4-7: UART ASYNCHRONOUS RECEIVE REQUIREMENTS

AC Specifications		Electrical Characteristics: Standard Operating Conditions (unless otherwise specified): Operating Temperature: $-40^{\circ}\text{C} \leq T_A \leq +85^{\circ}\text{C}$ (industrial) Operating Voltage V_{DD} range is described in Section 4.1					
Param. No.	Sym	Characteristic	Min	Typ	Max	Units	Conditions
IR110	TRXBIT	Receive Baud Rate	768	—	768	T _{OSC}	BAUD2:BAUD0 = 00
IR111	ERXBIT	Receive (RXPD and RXPREF pin detection) Baud rate Error (into MCP2140)	—	—	±1	%	
IR112	ERXBIT	Receive (RX pin) Baud rate Error (out of MCP2140) ⁽¹⁾	—	—	±1	%	
IR113	TTXRF	RX pin rise time and fall time	—	—	25	ns	

Note 1: This error is not additive to the IR111 parameter.

FIGURE 4-8: TXIR WAVEFORMS



TABLE 4-8: TXIR REQUIREMENTS

AC Specifications			Electrical Characteristics: Standard Operating Conditions (unless otherwise specified): Operating Temperature: $-40^{\circ}\text{C} \leq T_A \leq +85^{\circ}\text{C}$ (industrial) Operating Voltage VDD range is described in Section 4.1				
Param. No.	Sym	Characteristic	Min	Typ	Max	Units	Conditions
IR100A	TTXIRBIT	Transmit Baud Rate	768	—	768	TOSC	BAUD = 9600
IR121	TTXIRPW	TXIR pulse width	24	—	24	TOSC	
IR122	TTXIRP	TXIR bit period ⁽¹⁾	—	16	—	TBITCLK	

Note 1: TBITCLK = TTXBIT/16.

MCP2140

FIGURE 4-9: RXPД/RXPДREF WAVEFORMS

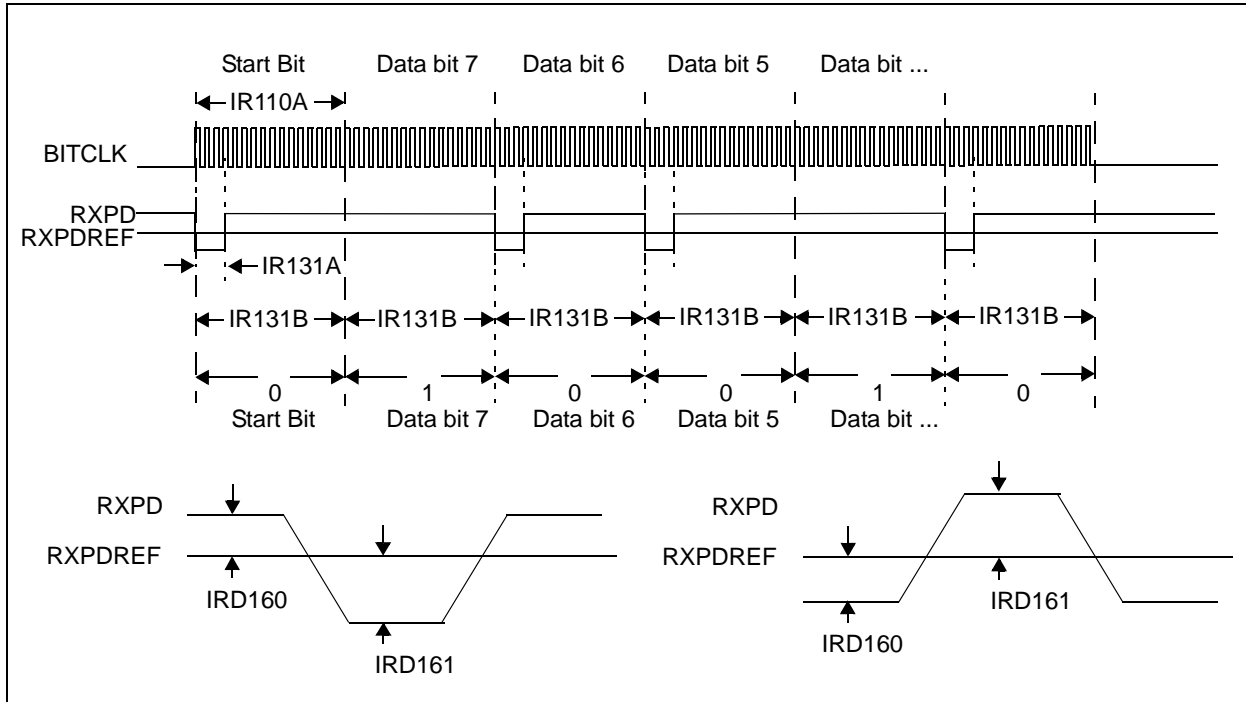

TABLE 4-9: RXPД/RXPДREF REQUIREMENTS

AC Specifications			Electrical Characteristics: Standard Operating Conditions (unless otherwise specified): Operating Temperature: $-40^{\circ}\text{C} \leq T_A \leq +85^{\circ}\text{C}$ (industrial) Operating Voltage V_{DD} range is described in Section 4.1				
Param. No.	Sym	Characteristic	Min	Typ	Max	Units	Conditions
IR110A	TRXPДBIT	Receive Baud Rate	768	—	768	TOSC	BAUD = 9600
IR131A	TRXPДPW	RXPД pulse width	0.01	—	1.5	μs	
IR132	TRXPДP	RXPД/RXPДREF bit period ⁽¹⁾	—	16	—	TBITCLK	
IRD060	VRXPД Δ	Quiescent Delta Voltage between RXPД and RXPДREF	20	—	—	mV	
IRD061	VRXPДE	IR Pulse Detect Delta Voltage (RXPД to RXPДREF)	30	—	—	mV	RXPД signal must cross RXPДREF signal level
IR133	TRESP	Response Time ⁽²⁾	—	—	400 *	ns	

* These parameters characterized but not tested.

Note 1: TBITCLK = TRXBIT/16.

2: Response time measured with RXPДREF at $(V_{DD} - 1.5\text{V})/2$, while RXPД transitions from VSS to VDD.

FIGURE 4-10: LOW POWER WAVEFORM



TABLE 4-10: LOW POWER REQUIREMENTS

AC Specifications			Electrical Characteristics: Standard Operating Conditions (unless otherwise specified): Operating Temperature: $-40^{\circ}\text{C} \leq T_A \leq +85^{\circ}\text{C}$ (industrial) Operating Voltage VDD range is described in Section 4.1				
Param. No.	Sym	Characteristic	Min	Typ	Max	Units	Conditions
IR140	TRXPD2OSC	RXPDP pulse edge to valid device oscillator ⁽¹⁾	—	—	4	ms	

Note 1: At 9600 Baud, 4 ms is 4 bytes (of the 11 byte repeated SOF character). This allows the MCP2140 to recognize a SOF character and properly receive the IR packet.

MCP2140

NOTES:

5.0 DC AND AC CHARACTERISTICS GRAPHS AND TABLES

Not available at this time.

MCP2140

NOTES:

6.0 PACKAGING INFORMATION

6.1 Package Marking Information

18-Lead PDIP (300 mil)



Example:

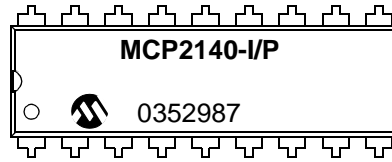

18-Lead SOIC (300 mil)



Example:

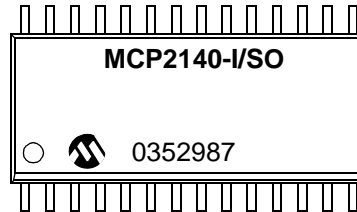

20-Lead SSOP (209 mil, 5.30 mm)



Example:

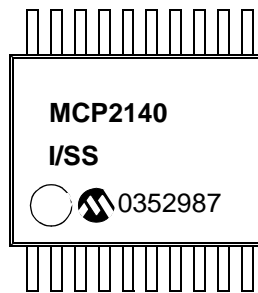

Legend:	XX...X	Customer-specific information
	Y	Year code (last digit of calendar year)
	YY	Year code (last 2 digits of calendar year)
	WW	Week code (week of January 1 is week '01')
	NNN	Alphanumeric traceability code
	(e3)	Pb-free JEDEC designator for Matte Tin (Sn)
	*	This package is Pb-free. The Pb-free JEDEC designator (e3) can be found on the outer packaging for this package.

Note: In the event the full Microchip part number cannot be marked on one line, it will be carried over to the next line, thus limiting the number of available characters for customer-specific information.

MCP2140

18-Lead Plastic Dual In-line (P) – 300 mil (PDIP)

Note: For the most current package drawings, please see the Microchip Packaging Specification located at <http://www.microchip.com/packaging>

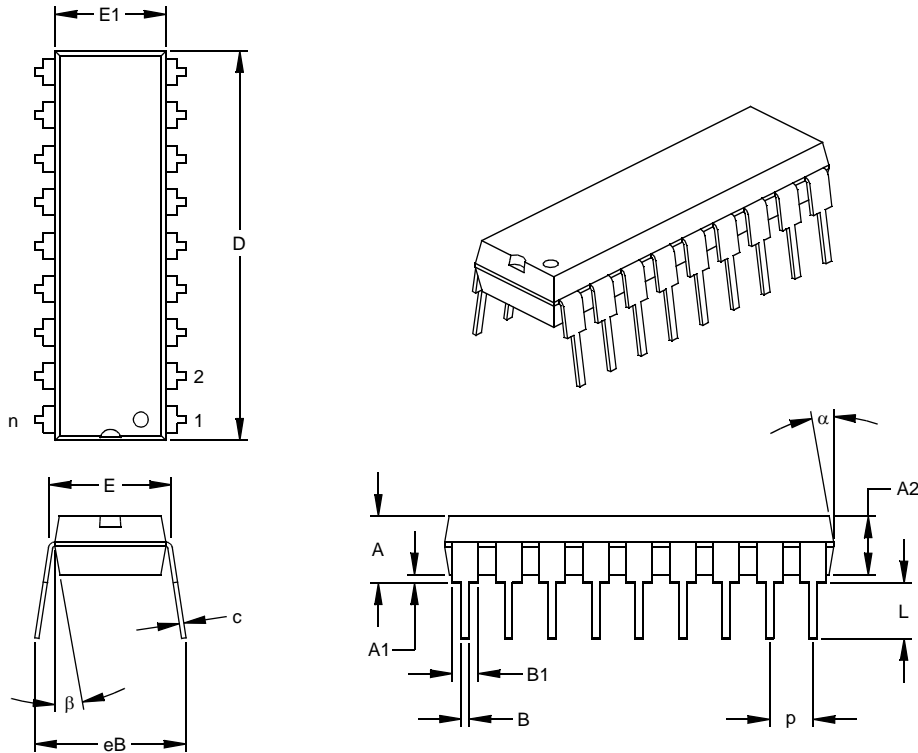

Dimension Limits	Units	INCHES*			MILLIMETERS		
		MIN	NOM	MAX	MIN	NOM	MAX
Number of Pins	n		18			18	
Pitch	p		.100			2.54	
Top to Seating Plane	A	.140	.155	.170	3.56	3.94	4.32
Molded Package Thickness	A2	.115	.130	.145	2.92	3.30	3.68
Base to Seating Plane	A1	.015			0.38		
Shoulder to Shoulder Width	E	.300	.313	.325	7.62	7.94	8.26
Molded Package Width	E1	.240	.250	.260	6.10	6.35	6.60
Overall Length	D	.890	.898	.905	22.61	22.80	22.99
Tip to Seating Plane	L	.125	.130	.135	3.18	3.30	3.43
Lead Thickness	c	.008	.012	.015	0.20	0.29	0.38
Upper Lead Width	B1	.045	.058	.070	1.14	1.46	1.78
Lower Lead Width	B	.014	.018	.022	0.36	0.46	0.56
Overall Row Spacing	§ eB	.310	.370	.430	7.87	9.40	10.92
Mold Draft Angle Top	α	5	10	15	5	10	15
Mold Draft Angle Bottom	β	5	10	15	5	10	15

* Controlling Parameter

§ Significant Characteristic

Notes:

Dimensions D and E1 do not include mold flash or protrusions. Mold flash or protrusions shall not exceed .010" (0.254mm) per side.

JEDEC Equivalent: MS-001

Drawing No. C04-007

18-Lead Plastic Small Outline (SO) – Wide, 300 mil (SOIC)

Note: For the most current package drawings, please see the Microchip Packaging Specification located at <http://www.microchip.com/packaging>



Units		INCHES*			MILLIMETERS		
Dimension	Limits	MIN	NOM	MAX	MIN	NOM	MAX
Number of Pins	n		18			18	
Pitch	P		.050			1.27	
Overall Height	A	.093	.099	.104	2.36	2.50	2.64
Molded Package Thickness	A2	.088	.091	.094	2.24	2.31	2.39
Standoff §	A1	.004	.008	.012	0.10	0.20	0.30
Overall Width	E	.394	.407	.420	10.01	10.34	10.67
Molded Package Width	E1	.291	.295	.299	7.39	7.49	7.59
Overall Length	D	.446	.454	.463	11.33	11.53	11.73
Chamfer Distance	h	.010	.020	.029	0.25	0.50	0.74
Foot Length	L	.016	.033	.050	0.41	0.84	1.27
Foot Angle	φ	0	4	8	0	4	8
Lead Thickness	c	.009	.011	.012	0.23	0.27	0.30
Lead Width	B	.014	.017	.020	0.36	0.42	0.51
Mold Draft Angle Top	α	0	12	15	0	12	15
Mold Draft Angle Bottom	β	0	12	15	0	12	15

* Controlling Parameter
 § Significant Characteristic

Notes:
 Dimensions D and E1 do not include mold flash or protrusions. Mold flash or protrusions shall not exceed .010" (0.254mm) per side.
 JEDEC Equivalent: MS-013
 Drawing No. C04-051

MCP2140

20-Lead Plastic Shrink Small Outline (SS) – 209 mil, 5.30 mm (SSOP)

Note: For the most current package drawings, please see the Microchip Packaging Specification located at <http://www.microchip.com/packaging>

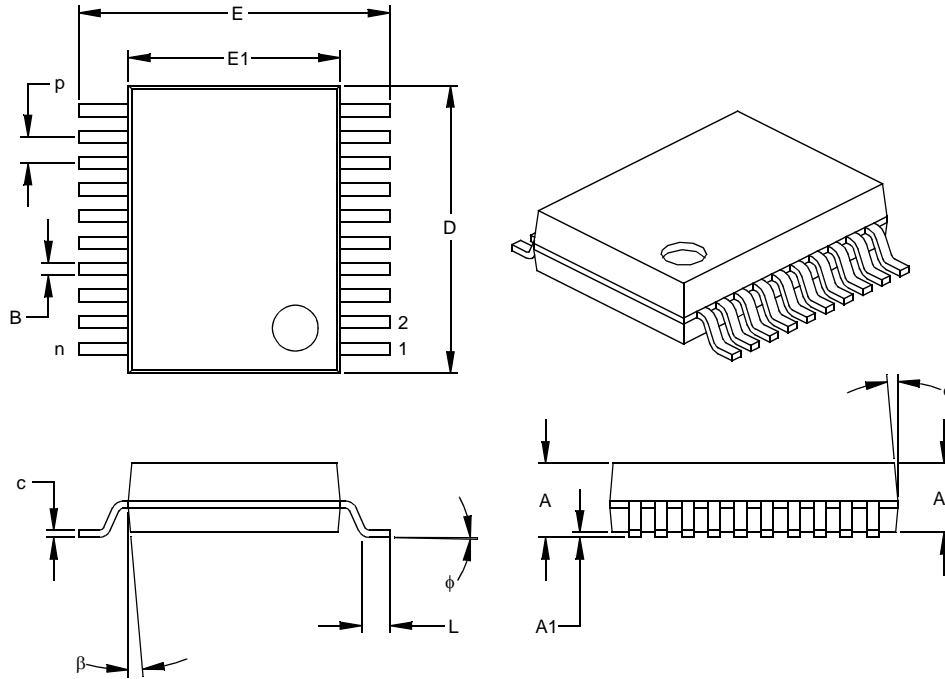

Units		INCHES*			MILLIMETERS		
Dimension Limits		MIN	NOM	MAX	MIN	NOM	MAX
Number of Pins	n		20			20	
Pitch	p		.026			0.65	
Overall Height	A	.068	.073	.078	1.73	1.85	1.98
Molded Package Thickness	A2	.064	.068	.072	1.63	1.73	1.83
Standoff §	A1	.002	.006	.010	0.05	0.15	0.25
Overall Width	E	.299	.309	.322	7.59	7.85	8.18
Molded Package Width	E1	.201	.207	.212	5.11	5.25	5.38
Overall Length	D	.278	.284	.289	7.06	7.20	7.34
Foot Length	L	.022	.030	.037	0.56	0.75	0.94
Lead Thickness	c	.004	.007	.010	0.10	0.18	0.25
Foot Angle	φ	0	4	8	0.00	101.60	203.20
Lead Width	B	.010	.013	.015	0.25	0.32	0.38
Mold Draft Angle Top	α	0	5	10	0	5	10
Mold Draft Angle Bottom	β	0	5	10	0	5	10

* Controlling Parameter

§ Significant Characteristic

Notes:

Dimensions D and E1 do not include mold flash or protrusions. Mold flash or protrusions shall not exceed .010" (0.254mm) per side.

JEDEC Equivalent: MO-150

Drawing No. C04-072

APPENDIX A: REVISION HISTORY

Revision A

- This is a new data sheet

Revision B (November 2012)

Added a note to each package outline drawing.

APPENDIX B: NETWORK LAYERING REFERENCE MODEL

Figure B-1 shows the ISO Network Layering Reference Model. The shaded areas are implemented by the MCP2140, while the cross-hatched area is implemented by an infrared transceiver. The unshaded areas should be implemented by the Host Controller.

FIGURE B-1: ISO REFERENCE LAYER MODEL



MCP2140

The IrDA Standard specifies the following protocols:

- Physical Signaling Layer (PHY)
- Link Access Protocol (IrLAP)
- Link Management Protocol/Information Access Service (IrLMP/IAS)

The IrDA data lists optional protocols. They are:

- Tiny TP
- IrTran-P
- IrOBEX
- IrLAN
- IrCOMM
- IrMC
- IrDA Lite

Figure B-2 shows the IrDA data protocol stack and which components are implemented by the MCP2140.

FIGURE B-2: IRDA DATA - PROTOCOL STACKS



B.1 IrDA STANDARD DATA PROTOCOLS SUPPORTED BY MCP2140

The MCP2140 supports these required IrDA standard protocols:

- Physical Signaling Layer (PHY)
- Link Access Protocol (IrLAP)
- Link Management Protocol/Information Access Service (IrLMP/IAS)

The MCP2140 also supports some of the optional protocols for IrDA data. The optional protocols that the MCP2140 implements are:

- Tiny TP
- IrCOMM

B.1.1 PHYSICAL SIGNAL LAYER (PHY)

The MCP2140 provides the following Physical Signal Layer specification support:

- Bidirectional communication
- Data Packets are protected by a CRC
 - 16-bit CRC for speeds up to 115.2 kbaud

Note: MCP2140 supports 9600 Baud only.

- Data Communication Rate
 - 9600 baud minimum data rate (with primary speed/cost steps of 115.2 kbaud)

Note: MCP2140 supports 9600 Baud only.

The following Physical Layer Specification is dependant on the optical transceiver logic used in the application. The specification states:

- Communication Range, which sets the end user expectation for discovery, recognition and performance.
 - Continuous operation from contact to at least 1 meter (typically 2 meters can be reached)
 - A low power specification reduces the objective for operation from contact to at least 20 cm (low power and low power) or 30 cm (low power and standard power)

B.1.2 IrLAP

The IrLAP protocol provides:

- Management of communication processes on the link between devices
- A device-to-device connection for the reliable, ordered transfer of data
- Device discover procedures
- Hidden node handling, 115.2 kbaud

Note: Not supported by MCP2140.

Figure B-3 identifies the key parts and hierarchy of the IrDA protocols. The bottom layer is the Physical layer, IrPHY. This is the part that converts the serial data to and from pulses of IR light. IR transceivers can't transmit and receive at the same time. The receiver has to wait for the transmitter to finish sending. This is sometimes referred to as a "Half-Duplex" connection. The IR Link Access Protocol (IrLAP) provides the structure for packets (or "frames") of data to emulate data that would normally be free to stream back and forth.

FIGURE B-3: IrDA STANDARD PROTOCOL LAYERS



Figure B-4 shows how the IrLAP frame is organized. The frame is preceded by some number of Beginning of Frame characters (BOFs). The value of the BOF is generally 0xC0, but 0xFF may be used if the last BOF character is a 0xC0. The purpose of multiple BOFs is to give the other station some warning that a frame is coming.

The IrLAP frame begins with an address byte ("A" field), then a control byte ("C" field). The control byte is used to differentiate between different types of frames and is also used to count frames. Frames can carry status, data or commands. The IrLAP protocol has a command syntax of its own. These commands are part of the control byte. Lastly, IrLAP frames carry data. This data is the information (or "I") field. The integrity of the frame is ensured with a 16-bit CRC, referred to as the Frame Check Sequence (FCS). The 16-bit CRC value is transmitted LSB first. The end of the frame is marked with an EOF character, which is always a 0xC1. The frame structure described here is used for all versions of IrDA protocols used for serial wire replacement for speeds up to 115.2 kbaud.

- Note 1:** The MCP2140 only supports communication baud rate of 9600 baud.
- 2:** Another IrDA standard that is entering into general usage is IR Object Exchange (IrOBEX). This standard is not used for serial connection emulation.
- 3:** IrDA communication standards faster than 115.2 kbaud use a different CRC method and physical layer.

FIGURE B-4: IrLAP FRAME



In addition to defining the frame structure, IrLAP provides the "housekeeping" functions of opening, closing and maintaining connections. The critical parameters that determine the performance of the link are part of this function. These parameters control how many BOFs are used, identify the speed of the link, how fast either party may change from receiving to transmitting, etc. IrLAP has the responsibility of negotiating these parameters to the highest common set so that both sides can communicate as quickly and reliably as possible.

MCP2140

B.1.3 IrLMP

The IrLMP protocol provides:

- Multiplexing of the IrLAP layer. This allows multiple channels above an IrLAP connection.
- Protocol and service discovery. This is accomplished via the Information Access Service (IAS).

When two devices that contain the IrDA standard feature are connected, there is generally one device that has something to do and the other device that has the resource to do it. For example, a laptop may have a job to print and an IrDA standard compatible printer has the resources to print it. In IrDA standard terminology, the laptop is a Primary device and the printer is the Secondary device. When these two devices connect, the Primary device must determine the capabilities of the Secondary device to determine if the Secondary device is capable of doing the job. This determination is made by the Primary device asking the Secondary device a series of questions. Depending on the answers to these questions, the Primary device may or may not elect to connect to the Secondary device.

The queries from the Primary device are carried to the Secondary device using IrLMP. The responses to these queries can be found in the Information Access Service (IAS) of the Secondary device. The IAS is a list of the resources of the Secondary device. The Primary device compares the IAS responses with its requirements and then makes the decision if a connection should be made.

B.1.4 LINK MANAGEMENT - INFORMATION ACCESS SERVICE (LM-IAS)

Each LM-IAS entity maintains an information database to provide:

- Information on services for other devices that contain the IrDA standard feature (Discovery)
- Information on services for the device itself
- Remote accessing of another device's information base

This is required so that clients on a remote device can find configuration information needed to access a service.

B.1.5 TINY TP

Tiny TP provides the flow control on IrLMP connections. An optional service of Segmentation and Reassembly can be handled.

B.1.6 IRCOMM

IrCOMM provides the method to support serial and parallel port emulation. This is useful for legacy COM applications, such as printers and modem devices.

The IrCOMM standard is a syntax that allows the Primary device to consider the Secondary device a serial device. IrCOMM allows for emulation of serial or parallel (printer) connections of various capabilities.

Note: The MCP2140 supports the 9-wire "cooked" service class of IrCOMM. Other service classes supported by IrCOMM are shown in [Figure B-5](#).

FIGURE B-5: IRCOMM SERVICE CLASSES

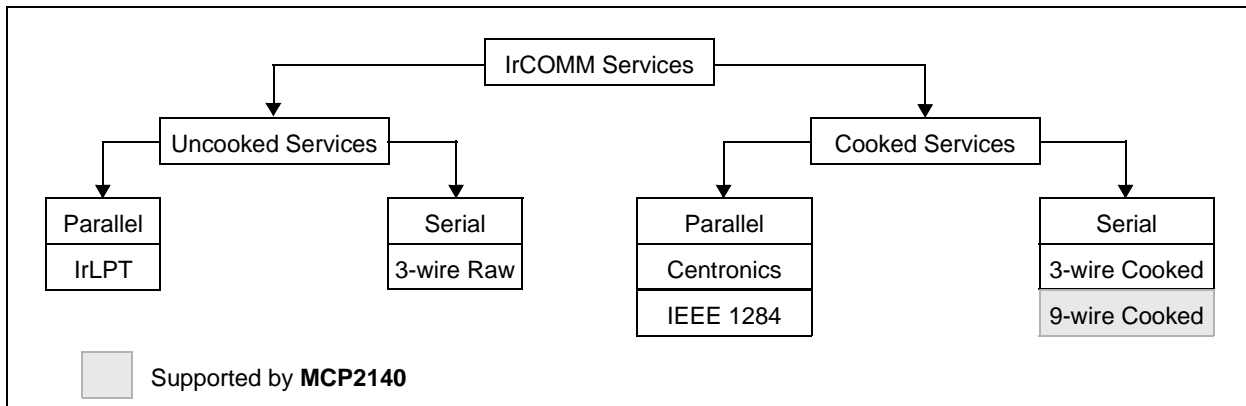

B.1.7 OTHER OPTIONAL IrDA DATA PROTOCOLS

Other IrDA data protocols have been developed to specific application requirements. These IrDA data protocols are briefly described in the following subsections. For additional information, please refer to the IrDA web site (www.IrDA.org).

B.1.7.1 IrTran-P

IrTran-P provides the protocol to exchange images with digital image capture devices/cameras.

Note: Not supported by MCP2140.

B.1.7.2 IrOBEX

IrOBEX provides OBject EXchange services. This is similar to HTTP.

Note: Not supported by MCP2140.

B.1.7.3 IrLAN

IrLAN describes a protocol to support IR wireless access to a Local Area Network (LAN).

Note: Not supported by MCP2140.

B.1.7.4 IrMC

IrMC describes how mobile telephony and communication devices can exchange information. This information includes phone book, calendar and message data.

Also how call control and real-time voice are handled (RTCON).

Note: Not supported by MCP2140.

B.1.7.5 IrDA Lite

IrDA Lite describes how to reduce the application code requirements, while maintaining compatibility with the full implementation.

Note: Not supported by MCP2140.

APPENDIX C: HOW DEVICES CONNECT

When two devices implementing the IrDA standard feature establish a connection using the IrCOMM protocol, the process is analogous to connecting two devices with serial ports using a cable. This is referred to as a “point-to-point” connection. This connection is limited to half-duplex operation because the IR transceiver cannot transmit and receive at the same time. The purpose of the IrDA protocols is to allow this half-duplex link to emulate, as much as possible, a full-duplex connection. In general, this is done by dividing the data into “packets”, or groups of data. These packets can then be sent back and forth, when needed, without risk of collision. The rules of how and when these packets are sent constitute the IrDA protocols.

When a wired connection is used, the assumption is made that both sides have the same communications parameters and features. A wired connection has no need to identify the other connector because it is assumed that the connectors are properly connected. In the IrDA standard, a connection process has been defined to identify other IrDA compatible devices and establish a communication link. There are three steps that these two devices go through to make this connection. They are:

- Normal Disconnect Mode (NDM)
- Discovery Mode
- Normal Connect Mode (NCM)

Figure C-1 shows the connection sequence.

C.1 Normal Disconnect Mode (NDM)

When two IrDA standard compatible devices come into range they must first recognize each other. The basis of this process is that one device has some task to accomplish and the other device has a resource needed to accomplish this task. One device is referred to as a Primary device and the other is referred to as a Secondary device. This distinction between Primary device and Secondary device is important. It is the responsibility of the Primary device to provide the mechanism to recognize other devices. So the Primary device must first poll for nearby IrDA standard compatible devices. During this polling, the default baud rate of 9600 baud is used by both devices.

For example, if you want to print from an IrDA equipped laptop to an IrDA printer, utilizing the IrDA standard feature, you would first bring your laptop in range of the printer. In this case, the laptop is the one that has something to do and the printer has the resource to do it. The laptop is called the Primary device and the printer is the Secondary device. Some data-capable cell phones have IrDA standard infrared ports. If you used such a cell phone with a Personal Digital Assis-

tant (PDA), the PDA that supports the IrDA standard feature would be the Primary device and the cell phone would be the Secondary device.

When a Primary device polls for another device, a nearby Secondary device may respond. When a Secondary device responds, the two devices are defined to be in the Normal Disconnect Mode (NDM) state. NDM is established by the Primary device broadcasting a packet and waiting for a response. These broadcast packets are numbered. Usually 6 or 8 packets are sent. The first packet is number 0, the last packet is usually number 5 or 7. Once all the packets are sent, the Primary device sends an ID packet, which is not numbered.

The Secondary device waits for these packets and then responds to one of the packets. The packet responds to determines the “timeslot” to be used by the Secondary device. For example, if the Secondary device responds after packet number 2, then the Secondary device will use timeslot 2. If the Secondary device responds after packet number 0, then the Secondary device will use timeslot 0. This mechanism allows the Primary device to recognize as many nearby devices as there are timeslots. The Primary device will continue to generate timeslots and the Secondary device should continue to respond, even if there’s nothing to do.

Note 1: The MCP2140 can only be used to implement a Secondary device.

2: The MCP2140 supports a system with only one Secondary device having exclusive use of the IrDA standard infrared link (known as “point-to-point” communication).

3: The MCP2140 always responds to packet number 2. This means that the MCP2140 will always use timeslot 2.

4: If another Secondary device is nearby, the Primary device may fail to recognize the MCP2140, or the Primary device may not recognize either of the devices.

C.2 Discovery Mode

Discovery mode allows the Primary device to determine the capabilities of the MCP2140 (Secondary device). Discovery mode is entered once the MCP2140 (Secondary device) has sent an XID response to the Primary device and the Primary device has completed sending the XIDs and then sends a Broadcast ID. If this sequence is not completed, then a Primary and Secondary device can stay in NDM indefinitely.

When the Primary device has something to do, it initiates Discovery. Discovery has two parts. They are:

- Link initialization
- Resource determination

The first step is for the Primary and Secondary devices to determine, and then adjust to, each other's hardware capabilities. These capabilities are parameters like:

- Data rate
- Turn around time
- Number of packets without a response
- How long to wait before disconnecting

Both the Primary and Secondary device begin communications at 9600 baud, which is the default baud rate. The Primary device sends its parameters, then the Secondary device responds with its parameters. For example, if the Primary supports all data rates up to 115.2 kbaud and the Secondary device only supports 9.6 kbaud, the link will be established at 9.6 kbaud.

Note: The MCP2140 is limited to a data rate of 9.6 kbaud.

Once the hardware parameters are established, the Primary device must determine if the Secondary device has the resources it requires. If the Primary device has a job to print, then it must know if it's talking to a printer, not a modem or other device. This determination is made using the Information Access Service (IAS). The job of the Secondary device is to respond to IAS queries made by the Primary device. The Primary device must ask a series of questions like:

- What is the name of your service?
- What is the address of this service?
- What are the capabilities of this device?

When all the Primary device's questions are answered, the Primary device can access the service provided by the Secondary device.

C.3 Normal Connect Mode (NCM)

Once discovery has been completed, the Primary device and Secondary device can freely exchange data.

Both the Primary device and the Secondary device check to make sure that data packets are received by the other without errors. Even when data is required to be sent, the Primary and Secondary devices will still exchange packets to ensure that the connection hasn't, unexpectedly, been dropped. When the Primary device has finished, it then transmits the close link command to the Secondary device. The Secondary device will confirm the close link command and both the Primary device and the Secondary device will revert to the NDM state.

Note: If the NCM mode is unexpectedly terminated for any reason (including the Primary device not issuing a close link command), the Secondary device will revert to the NDM state after a time delay (after the last frame has been received).

MCP2140

FIGURE C-1: HIGH LEVEL IRCOMM CONNECTION SEQUENCE



APPENDIX D: DB-9 PIN INFORMATION

Table D-1 shows the DB-9 pin information and the direction of the MCP2140 signals. The MCP2140 is designed for use in Data Communications Equipment (DCE) applications.

TABLE D-1: DB-9 SIGNAL INFORMATION

DB-9 Pin No.	Signal	Direction	Comment
1	CD	HC → MCP2140	Carrier Detect
2	RX	MCP2140 → HC	Received Data
3	TX	HC → MCP2140	Transmit Data
4	DTR	HC → MCP2140	Data Terminal Ready
5	GND	—	Ground
6	DSR	MCP2140 → HC	Data Set Ready
7	RTS	HC → MCP2140	Request to Send
8	CTS	MCP2140 → HC	Clear to Send
9	RI	HC → MCP2140	Ring Indicator

Legend: HC = Host Controller

APPENDIX E: KNOWN PRIMARY DEVICE COMPATIBILITY ISSUES

Table E-1 show the known issues of Primary Devices interfacing to the MCP2140.

TABLE E-1: PRIMARY DEVICE ISSUES

Primary Device	Operating System	Issue	Result
HP Jornada 720	HPC Pro/Windows CE™ 3.0 (Pocket PC)	Jornada 720 transmits 0xFF (not 0xC0) for extra SOF (Start-of-Frame) characters during NDM.	MCP2140 will not connect to the Jornada 720.
Personal Computers	Windows® 2000 (do not have list of which versions)	The operating system will reset if an IR device ID of "null" is received.	MCP2140 will not connect to the PC

MCP2140

NOTES:

PRODUCT IDENTIFICATION SYSTEM

To order or obtain information, e.g., on pricing or delivery, refer to the factory or the listed sales office.

<u>PART NO.</u>	<u>X</u>	<u>/XX</u>
Device	Temperature Range	Package
Device	MCP2140: Infrared Communications Controller MCP2140T: Infrared Communications Controller (Tape and Reel)	
Temperature Range	I = -40°C to +85°C	
Package	P = Plastic DIP (300 mil, Body), 18-lead SO = Plastic SOIC (300 mil, Body), 18-lead SS = Plastic SSOP (209 mil, Body), 20-lead	

Examples:

- a) MCP2140-I/P = Industrial Temp., PDIP packaging
- b) MCP2140-I/SO = Industrial Temp., SOIC package
- c) MCP2140T-I/SS = Tape and Reel, Industrial Temp., SSOP package

Sales and Support

Data Sheets

Products supported by a preliminary Data Sheet may have an errata sheet describing minor operational differences and recommended workarounds. To determine if an errata sheet exists for a particular device, please contact one of the following:

1. Your local Microchip sales office
2. The Microchip Worldwide Site (www.microchip.com)

Please specify which device, revision of silicon and Data Sheet (include Literature #) you are using.

Customer Notification System

Register on our web site (www.microchip.com/cn) to receive the most current information on our products.

MCP2140

NOTES:

Note the following details of the code protection feature on Microchip devices:

- Microchip products meet the specification contained in their particular Microchip Data Sheet.
- Microchip believes that its family of products is one of the most secure families of its kind on the market today, when used in the intended manner and under normal conditions.
- There are dishonest and possibly illegal methods used to breach the code protection feature. All of these methods, to our knowledge, require using the Microchip products in a manner outside the operating specifications contained in Microchip's Data Sheets. Most likely, the person doing so is engaged in theft of intellectual property.
- Microchip is willing to work with the customer who is concerned about the integrity of their code.
- Neither Microchip nor any other semiconductor manufacturer can guarantee the security of their code. Code protection does not mean that we are guaranteeing the product as “unbreakable.”

Code protection is constantly evolving. We at Microchip are committed to continuously improving the code protection features of our products. Attempts to break Microchip's code protection feature may be a violation of the Digital Millennium Copyright Act. If such acts allow unauthorized access to your software or other copyrighted work, you may have a right to sue for relief under that Act.

Information contained in this publication regarding device applications and the like is provided only for your convenience and may be superseded by updates. It is your responsibility to ensure that your application meets with your specifications. MICROCHIP MAKES NO REPRESENTATIONS OR WARRANTIES OF ANY KIND WHETHER EXPRESS OR IMPLIED, WRITTEN OR ORAL, STATUTORY OR OTHERWISE, RELATED TO THE INFORMATION, INCLUDING BUT NOT LIMITED TO ITS CONDITION, QUALITY, PERFORMANCE, MERCHANTABILITY OR FITNESS FOR PURPOSE. Microchip disclaims all liability arising from this information and its use. Use of Microchip devices in life support and/or safety applications is entirely at the buyer's risk, and the buyer agrees to defend, indemnify and hold harmless Microchip from any and all damages, claims, suits, or expenses resulting from such use. No licenses are conveyed, implicitly or otherwise, under any Microchip intellectual property rights.

Trademarks

The Microchip name and logo, the Microchip logo, dsPIC, FlashFlex, KEELOQ, KEELOQ logo, MPLAB, PIC, PICmicro, PICSTART, PIC³² logo, rPIC, SST, SST Logo, SuperFlash and UNI/O are registered trademarks of Microchip Technology Incorporated in the U.S.A. and other countries.

FilterLab, Hampshire, HI-TECH C, Linear Active Thermistor, MTP, SEEVAL and The Embedded Control Solutions Company are registered trademarks of Microchip Technology Incorporated in the U.S.A.

Silicon Storage Technology is a registered trademark of Microchip Technology Inc. in other countries.

Analog-for-the-Digital Age, Application Maestro, BodyCom, chipKIT, chipKIT logo, CodeGuard, dsPICDEM, dsPICDEM.net, dsPICworks, dsSPEAK, ECAN, ECONOMONITOR, FanSense, HI-TIDE, In-Circuit Serial Programming, ICSP, Mindi, MiWi, MPASM, MPF, MPLAB Certified logo, MPLIB, MPLINK, mTouch, Omniclient Code Generation, PICC, PICC-18, PICDEM, PICDEM.net, PICkit, PICtail, REAL ICE, rLAB, Select Mode, SQI, Serial Quad I/O, Total Endurance, TSHARC, UniWinDriver, WiperLock, ZENA and Z-Scale are trademarks of Microchip Technology Incorporated in the U.S.A. and other countries.

SQTP is a service mark of Microchip Technology Incorporated in the U.S.A.

GestIC and ULPP are registered trademarks of Microchip Technology Germany II GmbH & Co. & KG, a subsidiary of Microchip Technology Inc., in other countries.

All other trademarks mentioned herein are property of their respective companies.

© 2003-2012, Microchip Technology Incorporated, Printed in the U.S.A., All Rights Reserved.

 Printed on recycled paper.

ISBN: 9781620767429

Microchip received ISO/TS-16949:2009 certification for its worldwide headquarters, design and wafer fabrication facilities in Chandler and Tempe, Arizona; Gresham, Oregon and design centers in California and India. The Company's quality system processes and procedures are for its PIC[®] MCUs and dsPIC[®] DSCs, KEELOQ[®] code hopping devices, Serial EEPROMs, microperipherals, nonvolatile memory and analog products. In addition, Microchip's quality system for the design and manufacture of development systems is ISO 9001:2000 certified.

QUALITY MANAGEMENT SYSTEM
CERTIFIED BY DNV
== ISO/TS 16949 ==



MICROCHIP

Worldwide Sales and Service

AMERICAS

Corporate Office
2355 West Chandler Blvd.
Chandler, AZ 85224-6199
Tel: 480-792-7200
Fax: 480-792-7277
Technical Support:
<http://www.microchip.com/support>
Web Address:
www.microchip.com

Atlanta
Duluth, GA
Tel: 678-957-9614
Fax: 678-957-1455

Boston
Westborough, MA
Tel: 774-760-0087
Fax: 774-760-0088

Chicago
Itasca, IL
Tel: 630-285-0071
Fax: 630-285-0075

Cleveland
Independence, OH
Tel: 216-447-0464
Fax: 216-447-0643

Dallas
Addison, TX
Tel: 972-818-7423
Fax: 972-818-2924

Detroit
Farmington Hills, MI
Tel: 248-538-2250
Fax: 248-538-2260

Indianapolis
Noblesville, IN
Tel: 317-773-8323
Fax: 317-773-5453

Los Angeles
Mission Viejo, CA
Tel: 949-462-9523
Fax: 949-462-9608

Santa Clara
Santa Clara, CA
Tel: 408-961-6444
Fax: 408-961-6445

Toronto
Mississauga, Ontario,
Canada
Tel: 905-673-0699
Fax: 905-673-6509

ASIA/PACIFIC

Asia Pacific Office
Suites 3707-14, 37th Floor
Tower 6, The Gateway
Harbour City, Kowloon
Hong Kong
Tel: 852-2401-1200
Fax: 852-2401-3431

Australia - Sydney
Tel: 61-2-9868-6733
Fax: 61-2-9868-6755

China - Beijing
Tel: 86-10-8569-7000
Fax: 86-10-8528-2104

China - Chengdu
Tel: 86-28-8665-5511
Fax: 86-28-8665-7889

China - Chongqing
Tel: 86-23-8980-9588
Fax: 86-23-8980-9500

China - Hangzhou
Tel: 86-571-2819-3187
Fax: 86-571-2819-3189

China - Hong Kong SAR
Tel: 852-2401-1200
Fax: 852-2401-3431

China - Nanjing
Tel: 86-25-8473-2460
Fax: 86-25-8473-2470

China - Qingdao
Tel: 86-532-8502-7355
Fax: 86-532-8502-7205

China - Shanghai
Tel: 86-21-5407-5533
Fax: 86-21-5407-5066

China - Shenyang
Tel: 86-24-2334-2829
Fax: 86-24-2334-2393

China - Shenzhen
Tel: 86-755-8203-2660
Fax: 86-755-8203-1760

China - Wuhan
Tel: 86-27-5980-5300
Fax: 86-27-5980-5118

China - Xian
Tel: 86-29-8833-7252
Fax: 86-29-8833-7256

China - Xiamen
Tel: 86-592-2388138
Fax: 86-592-2388130

China - Zhuhai
Tel: 86-756-3210040
Fax: 86-756-3210049

ASIA/PACIFIC

India - Bangalore
Tel: 91-80-3090-4444
Fax: 91-80-3090-4123

India - New Delhi
Tel: 91-11-4160-8631
Fax: 91-11-4160-8632

India - Pune
Tel: 91-20-2566-1512
Fax: 91-20-2566-1513

Japan - Osaka
Tel: 81-66-152-7160
Fax: 81-66-152-9310

Japan - Yokohama
Tel: 81-45-471-6166
Fax: 81-45-471-6122

Korea - Daegu
Tel: 82-53-744-4301
Fax: 82-53-744-4302

Korea - Seoul
Tel: 82-2-554-7200
Fax: 82-2-558-5932 or
82-2-558-5934

Malaysia - Kuala Lumpur
Tel: 60-3-6201-9857
Fax: 60-3-6201-9859

Malaysia - Penang
Tel: 60-4-227-8870
Fax: 60-4-227-4068

Philippines - Manila
Tel: 63-2-634-9065
Fax: 63-2-634-9069

Singapore
Tel: 65-6334-8870
Fax: 65-6334-8850

Taiwan - Hsin Chu
Tel: 886-3-5778-366
Fax: 886-3-5770-955

Taiwan - Kaohsiung
Tel: 886-7-213-7828
Fax: 886-7-330-9305

Taiwan - Taipei
Tel: 886-2-2508-8600
Fax: 886-2-2508-0102

Thailand - Bangkok
Tel: 66-2-694-1351
Fax: 66-2-694-1350

EUROPE

Austria - Wels
Tel: 43-7242-2244-39
Fax: 43-7242-2244-393

Denmark - Copenhagen
Tel: 45-4450-2828
Fax: 45-4485-2829

France - Paris
Tel: 33-1-69-53-63-20
Fax: 33-1-69-30-90-79

Germany - Munich
Tel: 49-89-627-144-0
Fax: 49-89-627-144-44

Italy - Milan
Tel: 39-0331-742611
Fax: 39-0331-466781

Netherlands - Drunen
Tel: 31-416-690399
Fax: 31-416-690340

Spain - Madrid
Tel: 34-91-708-08-90
Fax: 34-91-708-08-91

UK - Wokingham
Tel: 44-118-921-5869
Fax: 44-118-921-5820

10/26/12



Стандарт Электрон Связь

Мы молодая и активно развивающаяся компания в области поставок электронных компонентов. Мы поставляем электронные компоненты отечественного и импортного производства напрямую от производителей и с крупнейших складов мира.

Благодаря сотрудничеству с мировыми поставщиками мы осуществляем комплексные и плановые поставки широчайшего спектра электронных компонентов.

Собственная эффективная логистика и склад в обеспечивает надежную поставку продукции в точно указанные сроки по всей России.

Мы осуществляем техническую поддержку нашим клиентам и предпродажную проверку качества продукции. На все поставляемые продукты мы предоставляем гарантию .

Осуществляем поставки продукции под контролем ВП МО РФ на предприятия военно-промышленного комплекса России , а также работаем в рамках 275 ФЗ с открытием отдельных счетов в уполномоченном банке. Система менеджмента качества компании соответствует требованиям ГОСТ ISO 9001.

Минимальные сроки поставки, гибкие цены, неограниченный ассортимент и индивидуальный подход к клиентам являются основой для выстраивания долгосрочного и эффективного сотрудничества с предприятиями радиоэлектронной промышленности, предприятиями ВПК и научно-исследовательскими институтами России.

С нами вы становитесь еще успешнее!

Наши контакты:

Телефон: +7 812 627 14 35

Электронная почта: sales@st-electron.ru

Адрес: 198099, Санкт-Петербург,
Промышленная ул, дом № 19, литера Н,
помещение 100-Н Офис 331