



**MCP401XEV  
Evaluation Board  
User's Guide**

---

**Note the following details of the code protection feature on Microchip devices:**

- Microchip products meet the specification contained in their particular Microchip Data Sheet.
- Microchip believes that its family of products is one of the most secure families of its kind on the market today, when used in the intended manner and under normal conditions.
- There are dishonest and possibly illegal methods used to breach the code protection feature. All of these methods, to our knowledge, require using the Microchip products in a manner outside the operating specifications contained in Microchip's Data Sheets. Most likely, the person doing so is engaged in theft of intellectual property.
- Microchip is willing to work with the customer who is concerned about the integrity of their code.
- Neither Microchip nor any other semiconductor manufacturer can guarantee the security of their code. Code protection does not mean that we are guaranteeing the product as "unbreakable."

Code protection is constantly evolving. We at Microchip are committed to continuously improving the code protection features of our products. Attempts to break Microchip's code protection feature may be a violation of the Digital Millennium Copyright Act. If such acts allow unauthorized access to your software or other copyrighted work, you may have a right to sue for relief under that Act.

---

Information contained in this publication regarding device applications and the like is provided only for your convenience and may be superseded by updates. It is your responsibility to ensure that your application meets with your specifications. MICROCHIP MAKES NO REPRESENTATIONS OR WARRANTIES OF ANY KIND WHETHER EXPRESS OR IMPLIED, WRITTEN OR ORAL, STATUTORY OR OTHERWISE, RELATED TO THE INFORMATION, INCLUDING BUT NOT LIMITED TO ITS CONDITION, QUALITY, PERFORMANCE, MERCHANTABILITY OR FITNESS FOR PURPOSE. Microchip disclaims all liability arising from this information and its use. Use of Microchip devices in life support and/or safety applications is entirely at the buyer's risk, and the buyer agrees to defend, indemnify and hold harmless Microchip from any and all damages, claims, suits, or expenses resulting from such use. No licenses are conveyed, implicitly or otherwise, under any Microchip intellectual property rights.

**Trademarks**

The Microchip name and logo, the Microchip logo, dsPIC, KEELOQ, KEELOQ logo, MPLAB, PIC, PICmicro, PICSTART, rfPIC and UNI/O are registered trademarks of Microchip Technology Incorporated in the U.S.A. and other countries.

FilterLab, Hampshire, HI-TECH C, Linear Active Thermistor, MXDEV, MXLAB, SEEVAL and The Embedded Control Solutions Company are registered trademarks of Microchip Technology Incorporated in the U.S.A.

Analog-for-the-Digital Age, Application Maestro, CodeGuard, dsPICDEM, dsPICDEM.net, dsPICworks, dsSPEAK, ECAN, ECONOMONITOR, FanSense, HI-TIDE, In-Circuit Serial Programming, ICSP, Mindi, MiWi, MPASM, MPLAB Certified logo, MPLIB, MPLINK, mTouch, Octopus, Omniscient Code Generation, PICC, PICC-18, PICDEM, PICDEM.net, PICKit, PICtail, PIC<sup>32</sup> logo, REAL ICE, rLAB, Select Mode, Total Endurance, TSHARC, UniWinDriver, WiperLock and ZENA are trademarks of Microchip Technology Incorporated in the U.S.A. and other countries.

SQTP is a service mark of Microchip Technology Incorporated in the U.S.A.

All other trademarks mentioned herein are property of their respective companies.

© 2010, Microchip Technology Incorporated, Printed in the U.S.A., All Rights Reserved.

 Printed on recycled paper.

**QUALITY MANAGEMENT SYSTEM**  
**CERTIFIED BY DNV**  
**== ISO/TS 16949:2002 ==**

*Microchip received ISO/TS-16949:2002 certification for its worldwide headquarters, design and wafer fabrication facilities in Chandler and Tempe, Arizona; Gresham, Oregon and design centers in California and India. The Company's quality system processes and procedures are for its PIC<sup>®</sup> MCUs and dsPIC<sup>®</sup> DSCs, KEELOQ<sup>®</sup> code hopping devices, Serial EEPROMs, microperipherals, nonvolatile memory and analog products. In addition, Microchip's quality system for the design and manufacture of development systems is ISO 9001:2000 certified.*



# MCP401XEV EVALUATION BOARD USER'S GUIDE

---

---

## Table of Contents

---

---

<b>Preface</b> .....	<b>1</b>
<b>Chapter 1. Product Overview</b>	
1.1 Introduction .....	5
1.2 What is the MCP401XEV Evaluation Board? .....	5
1.3 What the MCP401XEV Evaluation Board Kit Includes .....	6
<b>Chapter 2. Installation and Operation</b>	
2.1 Introduction .....	7
2.2 Features .....	8
2.3 Getting Started .....	9
2.4 MCP401XEV Evaluation Board Description .....	9
2.5 Configuring The PICkit Serial Analyzer .....	13
2.6 MCP40D18EV Demo Steps .....	23
<b>Appendix A. Schematic and Layouts</b>	
A.1 Introduction .....	27
A.2 Schematics and PCB Layout .....	27
A.3 Board - Schematic .....	28
A.4 Board - Top Trace, Silk and Pads .....	29
A.5 Board - Bottom Trace & Pads .....	30
A.6 Board - Layer 2 Ground Plane .....	31
A.7 Board - Layer 3 Power Plane .....	32
A.8 Board - Bottom Silk, Trace and Pads .....	33
<b>Appendix B. Bill of Materials (BOM)</b>	
<b>Worldwide Sales and Service</b> .....	<b>36</b>

# MCP401XEV Evaluation Board User's Guide

---

---

NOTES:

---

---

## Preface

---

---

### NOTICE TO CUSTOMERS

All documentation becomes dated, and this manual is no exception. Microchip tools and documentation are constantly evolving to meet customer needs, so some actual dialogs and/or tool descriptions may differ from those in this document. Please refer to our web site ([www.microchip.com](http://www.microchip.com)) to obtain the latest documentation available.

Documents are identified with a “DS” number. This number is located on the bottom of each page, in front of the page number. The numbering convention for the DS number is “DSXXXXA”, where “XXXX” is the document number and “A” is the revision level of the document.

For the most up-to-date information on development tools, see the MPLAB® IDE on-line help. Select the Help menu, and then Topics to open a list of available on-line help files.

## INTRODUCTION

This chapter contains general information that will be useful to know before using the MCP401XEV Evaluation Board. Items discussed in this chapter include:

- Document Layout
- Conventions Used in this Guide
- The Microchip Web Site
- The Microchip Web Site
- Customer Support
- Document Revision History

## DOCUMENT LAYOUT

This document describes how to use the MCP401XEV Evaluation Board as a development tool to emulate and debug firmware on a target board. The manual layout is as follows:

- **Chapter 1. “Product Overview”** – Important information about the MCP401XEV Evaluation Board.
- **Chapter 2. “Installation and Operation”** – Includes instructions on how to get started with this evaluation board.
- **Appendix A. “Schematic and Layouts”** – Shows the schematic and layout diagrams for the MCP401XEV Evaluation Board.
- **Appendix B. “Bill of Materials (BOM)”** – Lists the parts used to build the MCP401XEV Evaluation Board.

# MCP401XEV Evaluation Board User's Guide

---

## CONVENTIONS USED IN THIS GUIDE

This manual uses the following documentation conventions:

### DOCUMENTATION CONVENTIONS

Description	Represents	Examples
<b>Arial font:</b>		
Italic characters	Referenced books	<i>MPLAB<sup>®</sup> IDE User's Guide</i>
	Emphasized text	...is the <i>only</i> compiler...
Initial caps	A window	the Output window
	A dialog	the Settings dialog
	A menu selection	select Enable Programmer
Quotes	A field name in a window or dialog	"Save project before build"
Underlined, italic text with right angle bracket	A menu path	<u><i>File&gt;Save</i></u>
Bold characters	A dialog button	Click <b>OK</b>
	A tab	Click the <b>Power</b> tab
N'Rnnnn	A number in verilog format, where N is the total number of digits, R is the radix and n is a digit.	4'b0010, 2'hF1
Text in angle brackets < >	A key on the keyboard	Press <Enter>, <F1>

## RECOMMENDED READING

This user's guide describes how to use the MCP401XEV Evaluation Board. Other useful documents are listed below. The following Microchip documents are available and recommended as supplemental reference resources.

**AN1080 Application Note, “Understanding Digital Potentiometer Resistor Variations”, DS01080**

These data sheets provide detailed information regarding the MCP401X and MCP40D1X product families:

**MCP4017/18/19 Data Sheet, “7-bit Single  $\dot{I}^2C$  Digital POT with Volatile Memory in SC70”, DS22147**

**MCP40D17/18/19 Data Sheet, “7-bit Single  $\dot{I}^2C$  (with Command Code) Digital POT with Volatile Memory in SC70”, DS22152**

## THE MICROCHIP WEB SITE

Microchip provides online support via our web site at [www.microchip.com](http://www.microchip.com). This web site is used as a means to make files and information easily available to customers. Accessible by using your favorite Internet browser, the web site contains the following information:

- **Product Support** – Data sheets and errata, application notes and sample programs, design resources, user's guides and hardware support documents, latest software releases and archived software
- **General Technical Support** – Frequently Asked Questions (FAQs), technical support requests, online discussion groups, Microchip consultant program member listing
- **Business of Microchip** – Product selector and ordering guides, latest Microchip press releases, listing of seminars and events, listings of Microchip sales offices, distributors and factory representatives

## CUSTOMER SUPPORT

Users of Microchip products can receive assistance through several channels:

- Distributor or Representative
- Local Sales Office
- Field Application Engineer (FAE)
- Technical Support
- Development Systems Information Line

Customers should contact their distributor, representative or field application engineer (FAE) for support. Local sales offices are also available to help customers. A listing of sales offices and locations is included in the back of this document.

Technical support is available through the web site at: <http://support.microchip.com>

In addition, there is a Development Systems Information Line which lists the latest versions of Microchip's development systems software products. This line also provides information on how customers can receive currently available upgrade kits.

The Development Systems Information Line numbers are:

1-800-755-2345 – United States and most of Canada

1-480-792-7302 – Other International Locations

## DOCUMENT REVISION HISTORY

### Revision A (January 2010)

- Initial Release of this Document.



---

---

## Chapter 1. Product Overview

---

---

### 1.1 INTRODUCTION

This chapter provides an overview of the MCP401XEV Evaluation Board and covers the following topics:

- What is the MCP401XEV Evaluation Board?
- What the MCP401XEV Evaluation Board kit includes

### 1.2 WHAT IS THE MCP401XEV EVALUATION BOARD?

The MCP401XEV Evaluation Board allows the system designer to quickly evaluate the operation of Microchip Technology's MCP40D18 Digital Potentiometer device. This device is similar to the following devices:

- MCP40D17
- MCP40D19
- MCP4017
- MCP4018
- MCP4019

The board uses the SC70EV Generic PCB and has been populated for the MCP40D18. The 6-pin header (PICKit Serial) has been jumpered to the MCP40D18's appropriate pins. This allows the PICKit Serial to communicate with the device.

Additional blank PCBs may be ordered by using the order number: SC70EV. Each SC70EV kit contains 5 PCBs.

Figure 1-1 shows the top view of the PCB.

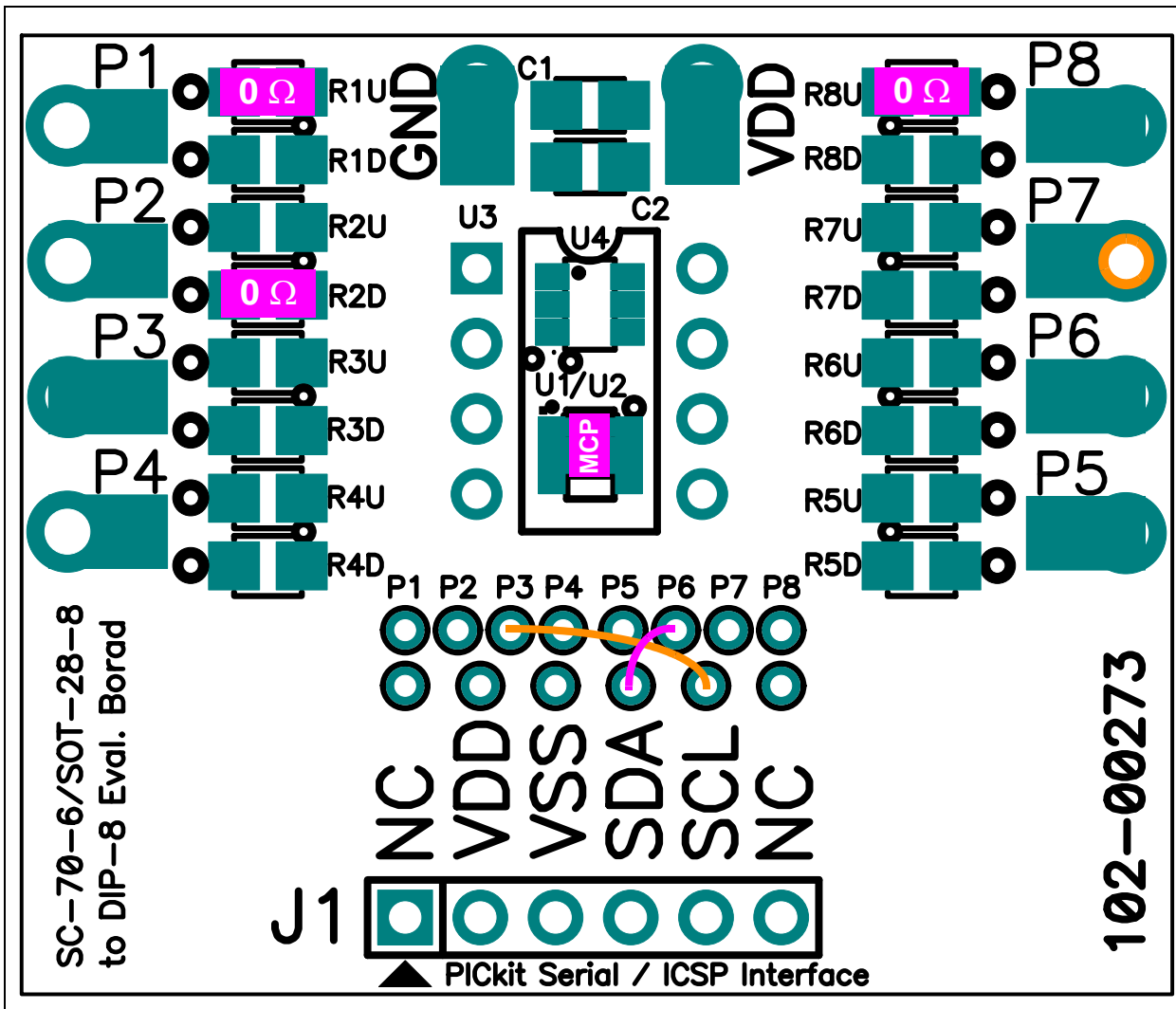

**FIGURE 1-1:** MCP401XEV Evaluation Board Using the SC70EV Evaluation Board (MCP40D18 installed in U1).

### 1.3 WHAT THE MCP401XEV EVALUATION BOARD KIT INCLUDES

This MCP401XEV Evaluation Board kit includes:

- MCP401XEV Evaluation Board
- One SC70EV Blank PCB, 102-00273.  
Extra blank PCBs can be ordered (order #: SC70EV)
- Important Information Sheet

---

---

## Chapter 2. Installation and Operation

---

---

### 2.1 INTRODUCTION

The MCP401XEV Evaluation Board allows the system designer to quickly evaluate the operation of the MCP40D18 10 k $\Omega$  (-103) Digital Potentiometer device using the PICkit Serial Analyzer. The PICkit Serial Analyzer is available separately (order number: DV164122).

The MCP401XEV Evaluation Board is a minimum configuration for the device. As well as the device, other desired passive components (resistors and capacitors) and connection posts may be installed.

The MCP401XEV Evaluation Board can also be very easily jumpered into a customer's existing circuit. This gives an indication of the MCP40D18 device performance, but is affected by the jumper lead length and the EM noise that the jumpers pick up.

The MCP401XEV Evaluation board uses the generic SC70EV Evaluation Board PCB, and includes a second blank PCB. Additional PCB may be ordered (order number: SC70EV). The SC70EV kit includes 5 blank PCBs.

Other boards can be easily built up using the SC70EV PCB to allow evaluation of other resistance options (5 k $\Omega$ , 50 k $\Omega$ , or 100 k $\Omega$ ) or any of the other devices in the following packages:

- SC70 package (uses I<sup>2</sup>C interface)
  - MCP4017, MCP4018, MCP4019, MCP40D17, or MCP40D19
- SOT-23 package (uses Up/Down interface)
  - MCP4012, MCP4013, MCP4014, MCP4022, MCP4023, or MCP4024
- DIP-8 Package (uses SPI interface)
  - MCP4131, MCP4141, MCP4151, or MCP4161

The MCP401XEV Evaluation Board also has a 6-pin interface (PICkit Serial, ICSP, etc.) whose signals can easily be jumpered to any of the device's pins.

Additional information on using the SC70EV Evaluation Board PCB or for modifying the MCP401XEV board is available in the SC70EV User's Guide (DS51874). **Appendix A. "Schematic and Layouts"** has information on the PCB schematic and layout while Figure 2-2 shows components that are installed on the PCB.

## 2.2 FEATURES

The MCP401XEV Evaluation Board has the following features:

- MCP40D18-103AE/LT is installed (I<sup>2</sup>C address of 7Ch)
- 0Ω resistors connect MCP40D18 VDD and VSS signals to the appropriate Power or Ground plane (see Figure 2-2)
- 0Ω resistors connect MCP40D18 A terminal signal to Power plane, Resistor Network is in a voltage divider configuration (see Figure 2-2)
- Through-hole connection terminal (Orange) for the Wiper pin
- Connection terminals for all device pins (either through-hole or surface-mount)
- Footprints for optional passive components (SMT 805 footprint) for:
  - Power supply filtering (C<sub>1</sub> and C<sub>2</sub> footprints)
  - Device bypass capacitor (RxD footprint for device pin connected to V<sub>DD</sub>)
- Silk-screen area to write specifics of implemented circuit (on back of PCB), such as MCP4018 10 kΩ
- PICKit Serial Analyzer Header

The included SC70EV Board has the following features:

- Connection terminals may be either through-hole or surface-mount
- Three package type footprints supported:
  - SC70-6
  - SC70-5
  - SC70-3
  - SOT-23-8
  - SOT-23-6
  - SOT-23-5
  - SOT-23-3
  - DIP-8 (300 millimeter spacing)
- Footprints for optional passive components (SMD 805 footprint) for:
  - Power supply filtering (C<sub>1</sub> and C<sub>2</sub> footprints)
  - Device bypass capacitor (RxD footprint for device pin connected to V<sub>DD</sub>)
  - Output filtering (RxD footprint)
  - Output pull-up resistor (RxU footprint)
  - Output pull-down resistor (RxD footprint)
  - Output loading resistor (RxD footprint)
- Silk-screen area to write specifics of implemented circuit (on back of PCB), such as MCP4018 10 kΩ
- Can be used for SC70 or SOT-23 to DIP-8 converter
- PICKit Serial Analyzer / PICKit 2 Programming (ICSP) Header

## 2.3 GETTING STARTED

The MCP401XEV Evaluation Board allows quick evaluation of the MCP40D18-103AE/LT device. This device is in the potentiometer configuration with terminal B internally tied to ground. This device has an  $R_{AB}$  resistance that is typically 10 k $\Omega$  and has a slave I<sup>2</sup>C device address of 7Ch. Evaluation can be done by:

- Using the PICkit Serial Analyzer for interface communication
- Jumpering the MCP401XEV Evaluation Board into your application circuit to control the MCP40D18-103A device

This user guide will discuss the steps needed to evaluate the MCP40D18-103AE/LT device using the PICkit Serial Analyzer (order number: DV164122).

**Section 2.5 “Configuring The PICkit Serial Analyzer”** shows the steps to configure the PICkit Serial Analyzer as well as create User Script files which are used to communicate with the MCP40D18, based on the device's I<sup>2</sup>C communication protocol format.

## 2.4 MCP401XEV EVALUATION BOARD DESCRIPTION

The MCP401XEV Evaluation Board uses the flexible SC70EV Evaluation Board PCB. This simple Evaluation Board allows the system designer to quickly evaluate the operation of the MCP40D18-103A device ( $R_{AB(TYP)} = 10\text{ k}\Omega$  and has a device slave I<sup>2</sup>C address = 7Ch) using the PICkit Serial Analyzer or by jumpering the board into their application system. The PICkit Serial Analyzer is available separately (order number: DV164122).

### 2.4.1 The Hardware

Figure 2-2 shows the component layout of the MCP401XEV Evaluation Board. This is a small four-layer board (1.43" x 1.255" (36.322 mm x 31.877 mm)). There are ten connection points/pads that can use either through-hole or surface-mount connector posts.

The pad labeled VDD is connected to the PCB power plane, while the pad labeled VSS is connected to the PCB ground plane. All the passive components that are connected to VDD or VSS are connected to either the power plane or ground plane.

The eight remaining PCB pads correspond to the device pins (i.e.; pad 1 connects to pin 1).

Each pad has two passive components associated with them: a pull-up resistor and a pull-down resistor. The pull-up resistor is always RXU and the pull-down resistor is RXD. The “X” is a numeric value that corresponds to a particular pad (1 to 8). As an example, Pad 5's pull-up resistor is R5U. Capacitor C1 and C2 are the power supply filtering capacitors. For whichever pin is the device's VDD, the RXD component footprint can be used for the device's bypass capacitor. Table 2-2 describes the components.

A 6-pin header interface is available to support the PICkit Serial or the PICmicro In-Circuit Serial Programming (ICSP) interface.

# MCP401XEV Evaluation Board User's Guide

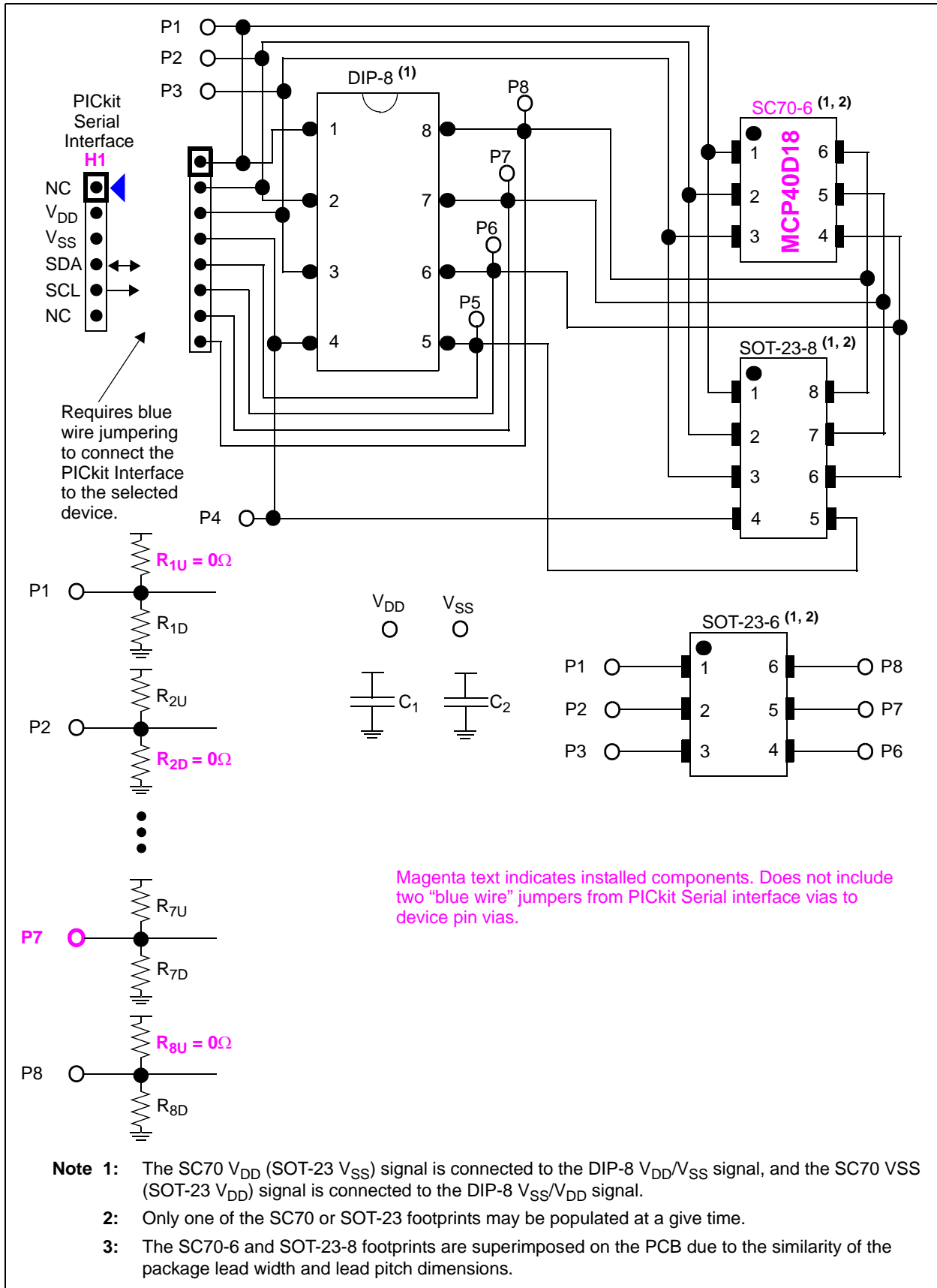

**FIGURE 2-1:** SC70EV Evaluation Board Circuit.

# Installation and Operation

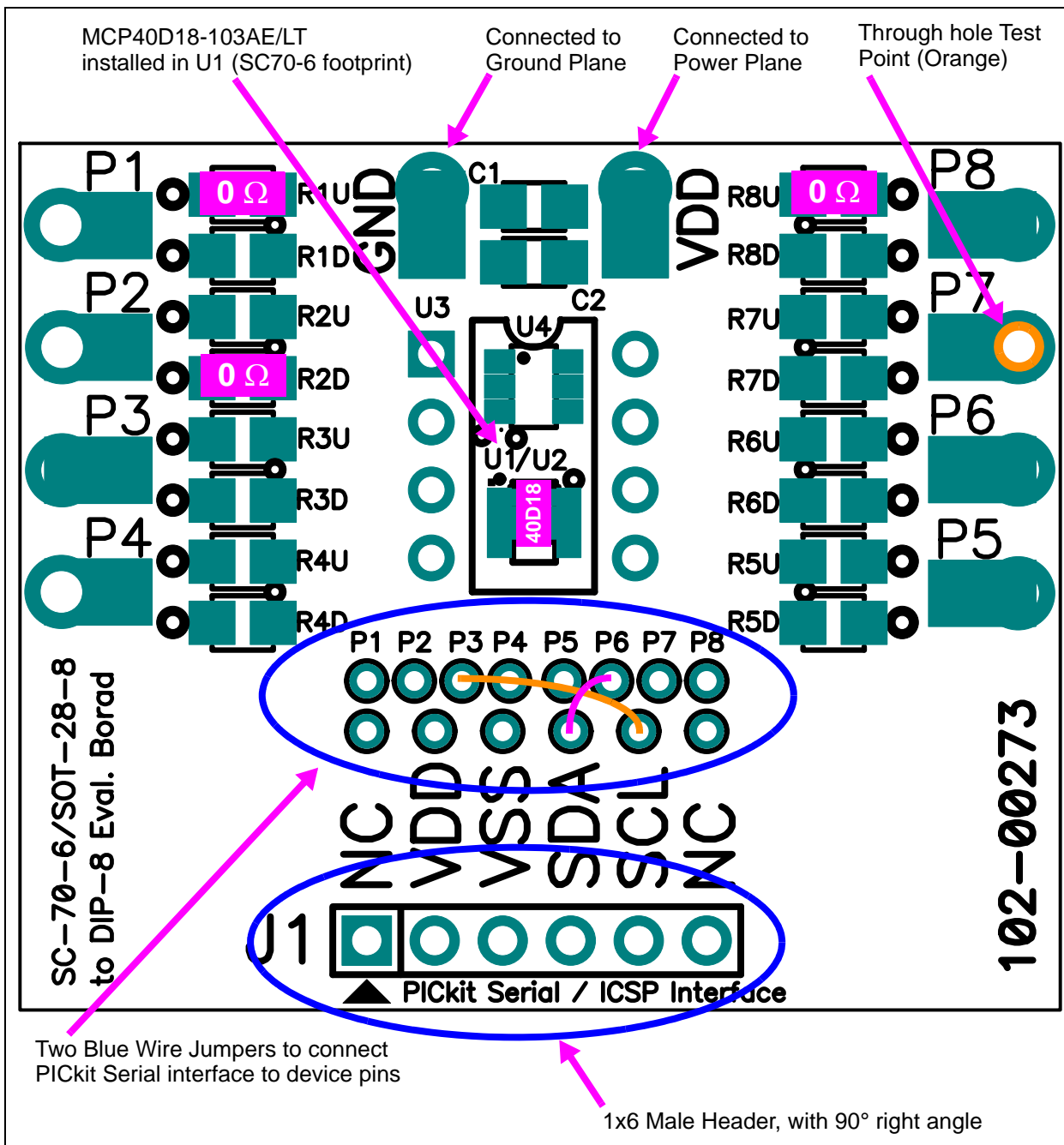

**FIGURE 2-2:** MCP401XEV Evaluation Board Component Placement Using the SC70EV Evaluation Board (Top).

# MCP401XEV Evaluation Board User's Guide

**TABLE 2-1: INSTALLED PASSIVE COMPONENTS (2)**

Component	Description	Comment
R1U, R8U	0Ω SMT 805	Pull-up resistor
R2D	0Ω SMT 805	Pull-down resistor (1)
U1	MCP40D18-103AE/LT	10 kΩ, Device I <sup>2</sup> C Slave Address = 7Ch
P7	Test Point - through hole connector (Orange)	
J1	1x6 Male Header, 100 mil spacing 90° angle.	1 x 6 male Header
—	Blue Wire: J1 SCL via to P3 via J1 SDA via to P6 via	See Figure 2-2

**Note 1:** Whichever pin is the device's VDD pin, that corresponding RXD footprint can be used for the device's bypass capacitor. So if Pin 8 is the device's VDD pin, then install the bypass capacitor in the R8D footprint.

**2:** All passive components use the surface mount 805 footprint.

**TABLE 2-2: OPTIONAL PASSIVE COMPONENTS - NOT INSTALLED (2)**

Component	Comment
C1, C2	Power supply bypass capacitors (3)
R2U, R3U, R4U, R5U, R6U, R7U	Pull-up resistor
R1D, R3D, R4D, R5D, R6D, R7D, R8D	Pull-down resistor (1)
U2, U3, U4	Alternate package footprints
VDD, GND	Power and Ground plane connection points
P1, P2, P3, P4, P5, P6, P8	Test Point connectors

**Note 1:** Whichever pin is the device's VDD pin, that corresponding RXD footprint can be used for the device's bypass capacitor. So if Pin 8 is the device's VDD pin, then install the bypass capacitor in the R8D footprint.

**2:** All passive components use the surface mount 805 footprint.

**3:** If board is powered via the VDD and GND connection points, the use of bypass capacitors on C1 and C2 may improve performance. The benefit is reduced if the board is powered via the PICKit Serial interface.



## 2.5 CONFIGURING THE PICKIT SERIAL ANALYZER

Figure 2-3 shows the PICKit Serial Window after the program has started. The Transaction window indicates if the PICKit Serial GUI located the PICKit Serial Analyzer Hardware. When starting the PICKit Serial Analyzer for the 1st time, some setup questions may be asked. If you have any questions, please refer to the PICKit Serial Analyzer documentation, available at [www.Microchip.com/PICKitSerial](http://www.Microchip.com/PICKitSerial).

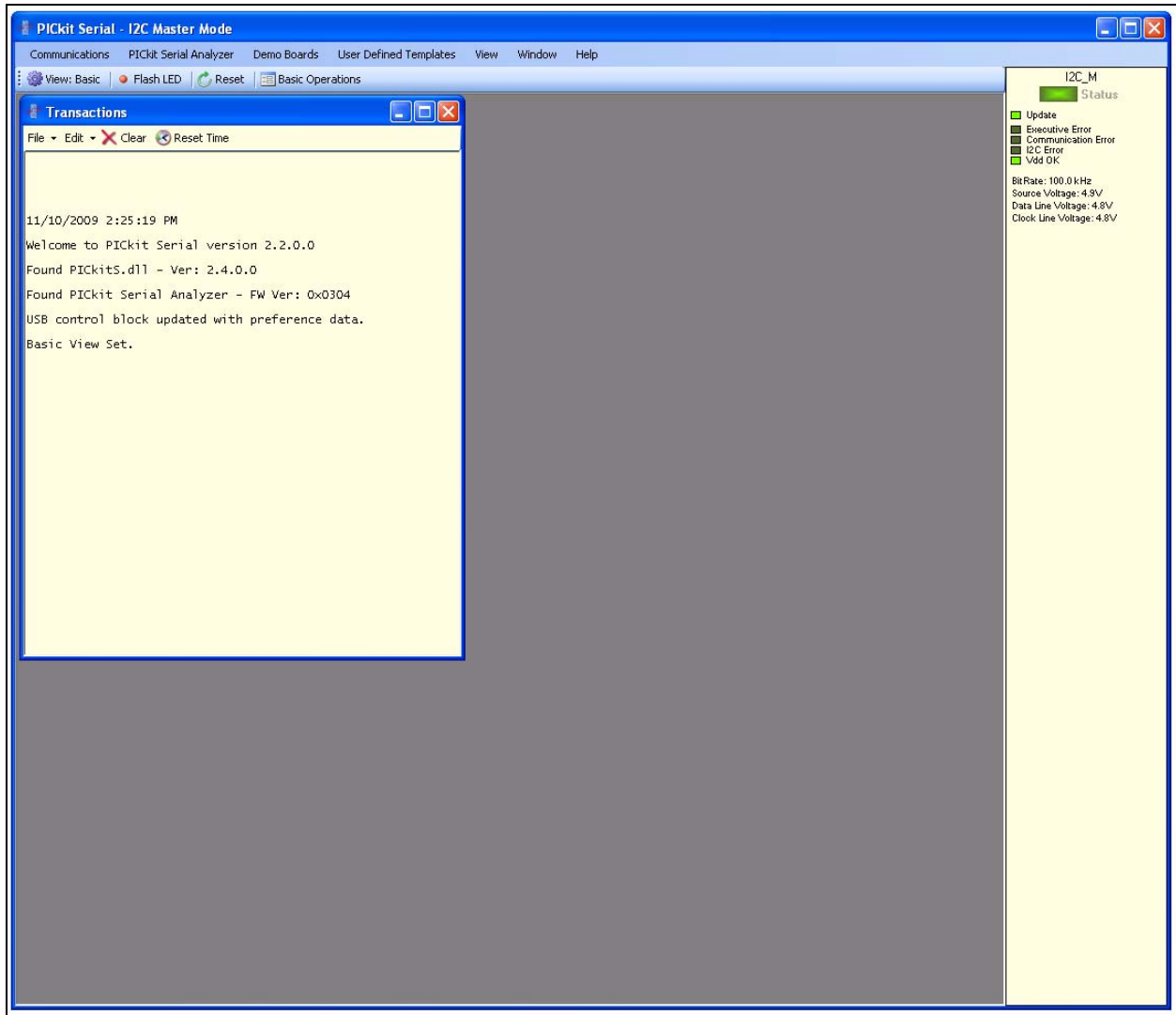

**FIGURE 2-3:** PICKit Serial Main Window at Startup.

# MCP401XEV Evaluation Board User's Guide

We need to select the PICkit Serial Analyzer GUI to be in I<sup>2</sup>C Master mode. Figure 2-4 shows how to select the proper mode. Select *PICkit Serial Analyzer* -> *Select Communications Mode* -> *I2C Master* menu item (make sure the I2C Master item is checked).

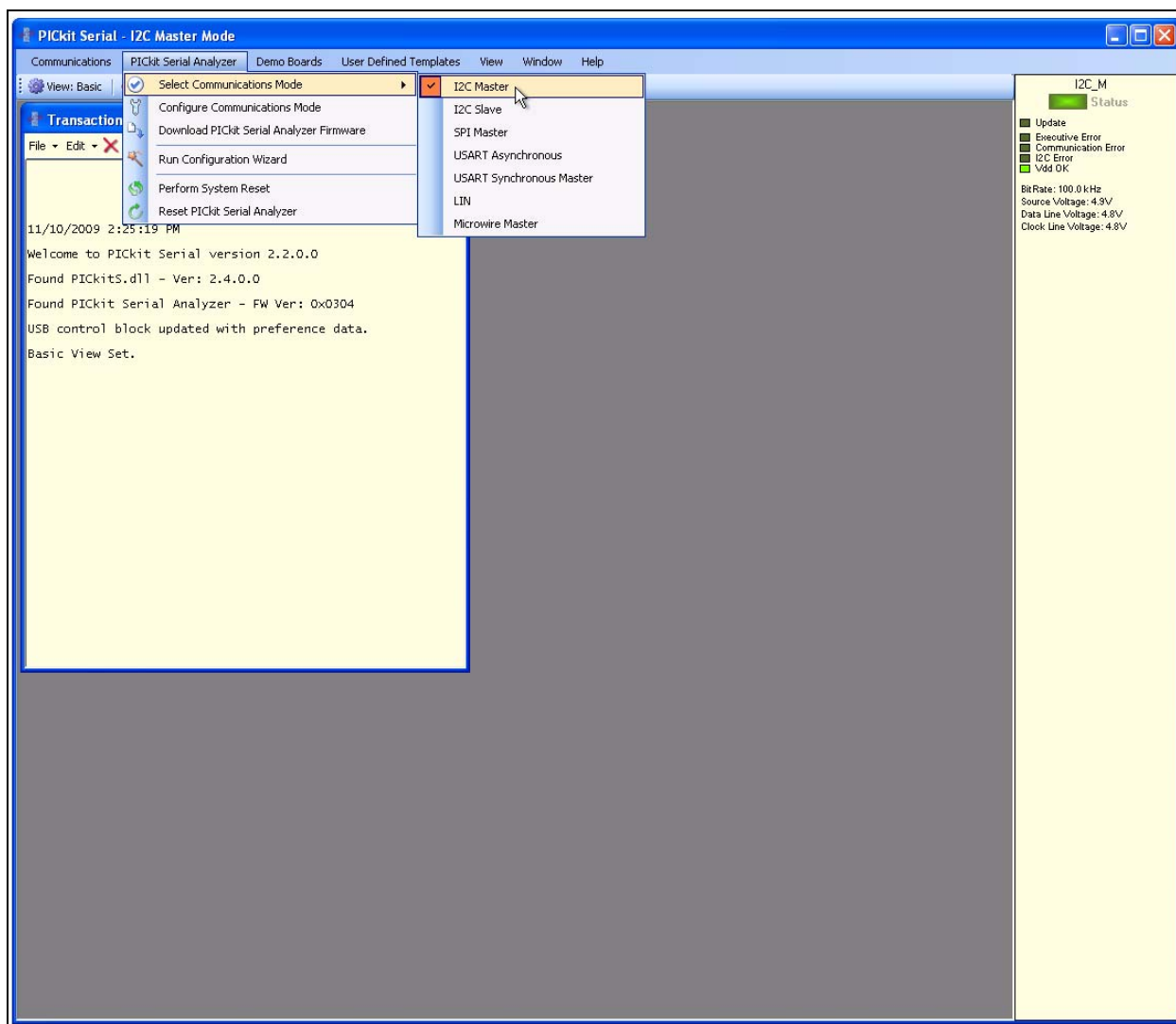

**FIGURE 2-4:** PICkit Serial Selecting Communications Mode.

# Installation and Operation

Now we need to configure the mode that we have selected. Figure 2-5 shows how to select the communications mode. Select *PICKit Serial Analyzer -> Configure Communications Mode* menu item. This will open a new window.

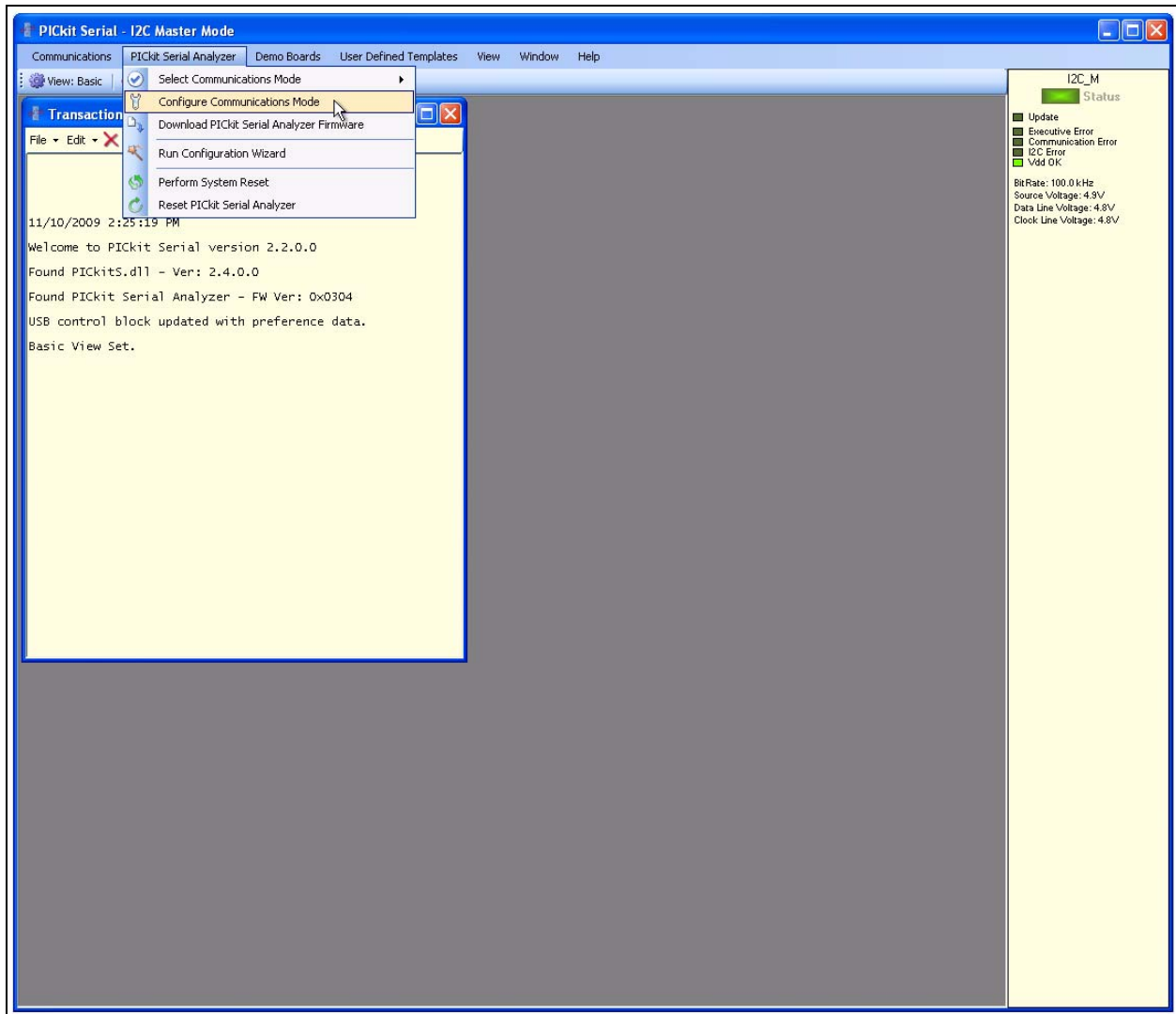

**FIGURE 2-5:** PICKit Serial Main Window at Startup.

# MCP401XEV Evaluation Board User's Guide

Figure 2-6 shows the Configure Communications Mode window. Ensure that your window options and settings are the same as in this window, and then select the “Save Changes” button.

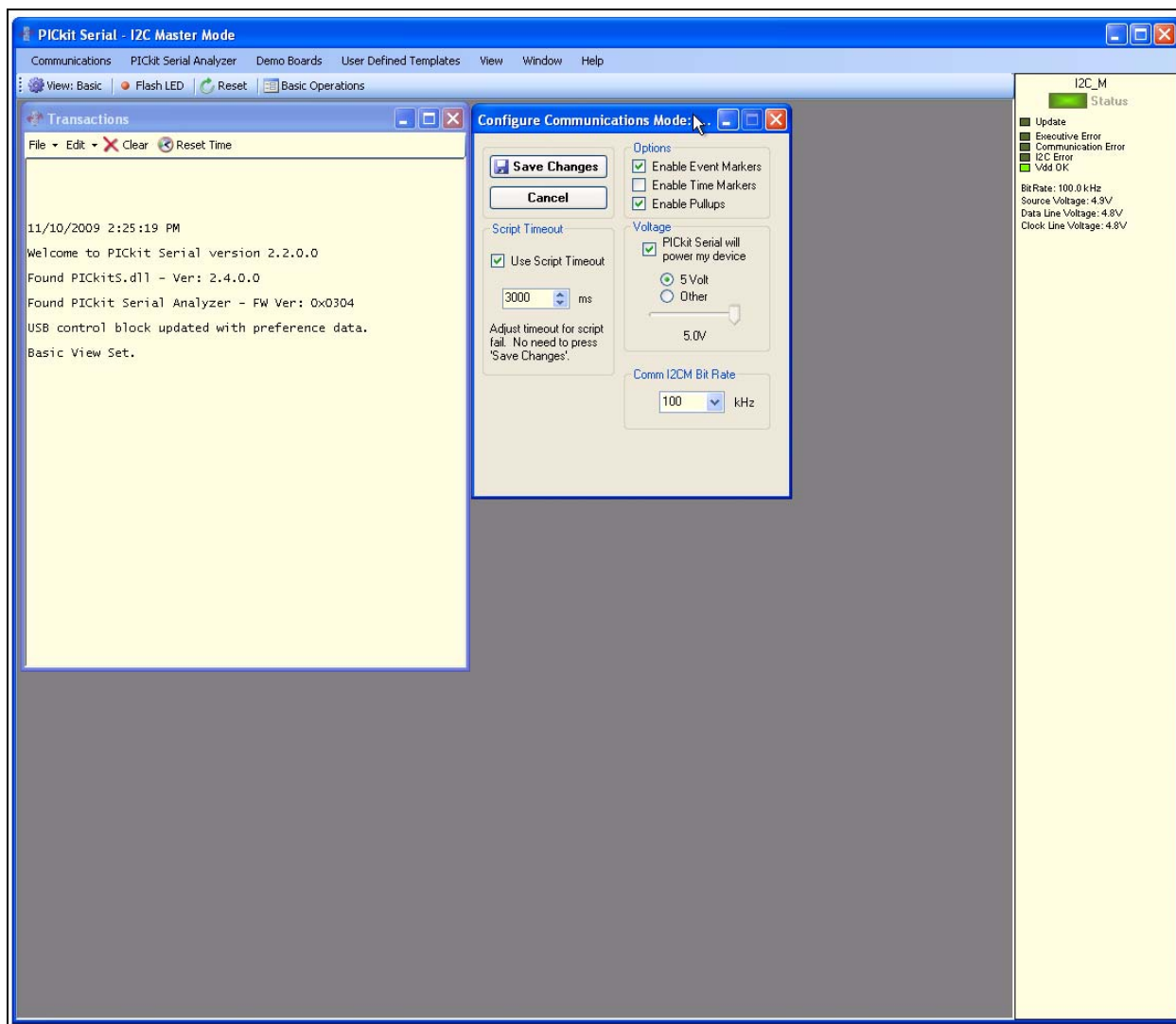

**FIGURE 2-6:** PICkit Serial Configure Communications Mode Window.

# Installation and Operation

Now we are going to create some custom scripts to match the MCP40D18 read and write commands. To open the Script Builder window, select the Communications -> Script -> Script Builder menu item (see Figure 2-7).

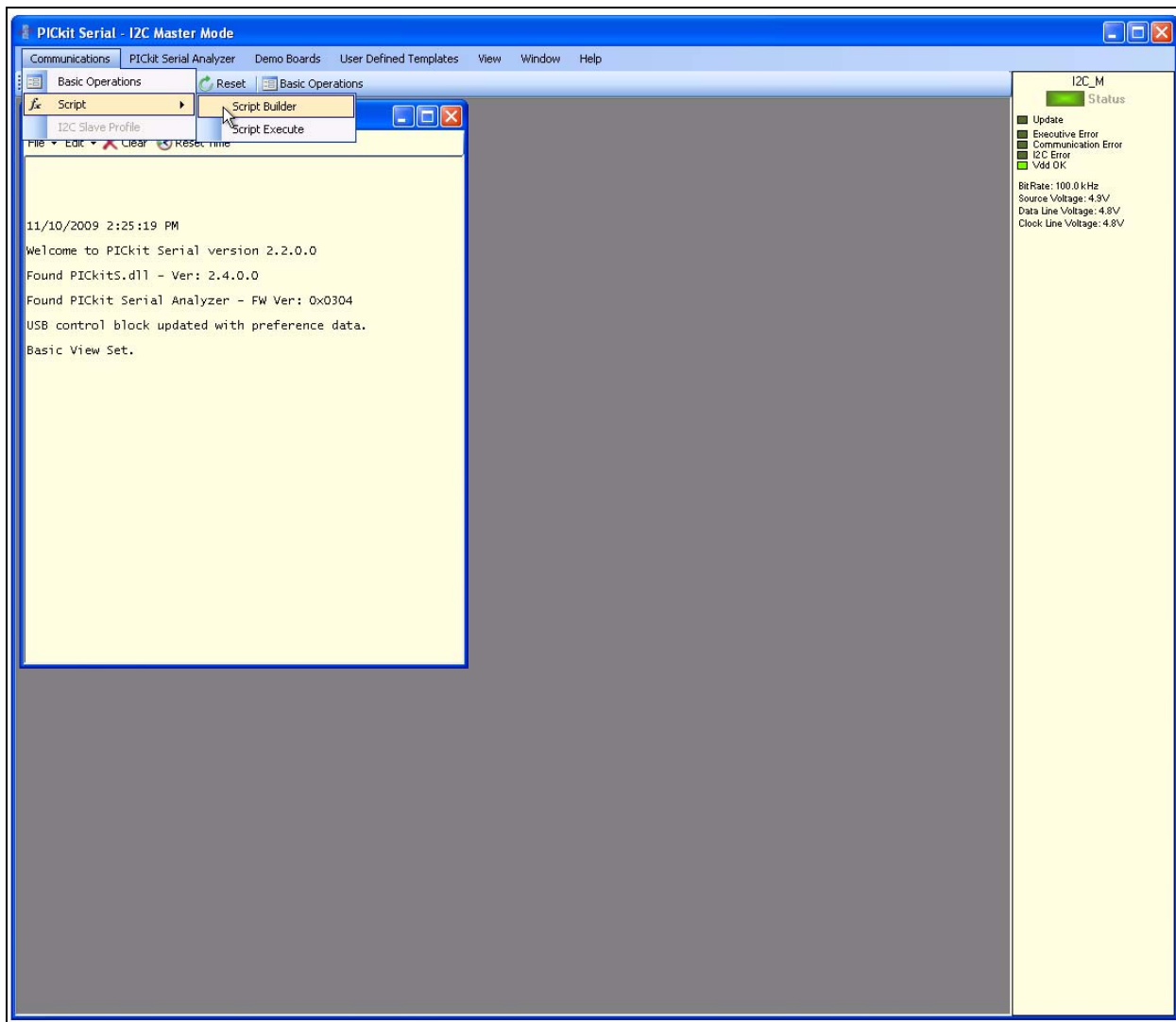

**FIGURE 2-7:** PICkit Serial - Script Bulider Menu Selection.

# MCP401XEV Evaluation Board User's Guide

This will open the Script Builder window (Figure 2-8). In this window we see five Example I<sup>2</sup>C Master Scripts. We will use the ReadAddrA8 and WriteAddrA8 Example Script Files to create our User I<sup>2</sup>C Master Scripts.

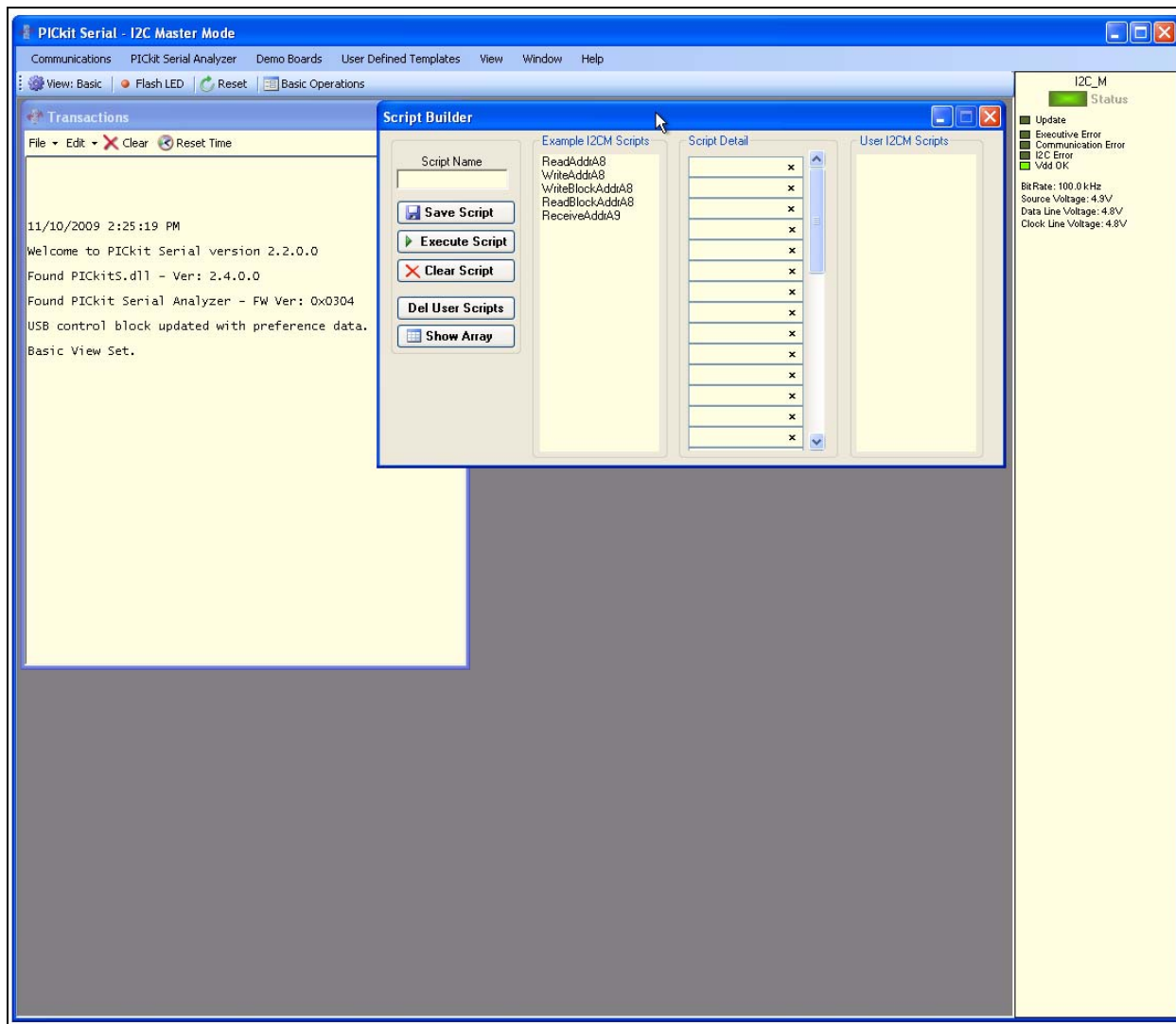

**FIGURE 2-8:** PICkit Serial Main Window at Startup.

# Installation and Operation

Double clicking on the WriteAddrA8 Example I2CM Script will load the Script Details. Figure 2-9 shows what the values mean in the Script Details. These values are hex numbers.

The first value (03h), is the number of bytes that will be written. The second byte is the I<sup>2</sup>C Slave address (A8h) of the device with the Read/Write bit forced to '0' (an I<sup>2</sup>C write). The next two bytes (02h and 33h) are data bytes, and these value will be dependent on the slave I<sup>2</sup>C device protocol format and the desired operation.

The screenshot shows the 'Script Builder' window with the 'WriteAddrA8' script selected. The 'Script Detail' pane shows the following sequence of operations:

Operation	Value	Annotation
I2CSTART		
I2CWRTBYT	03	Number of Bytes that will be written
	A8	I <sup>2</sup> C Slave Address + Read/Write bit (R/W bit = 0)
	02	Data Byte #1 (1)
	33	Data Byte #2 (1)
I2CSTOP		

**Note 1:** Function depends on devices I<sup>2</sup>C Protocol Format.

**FIGURE 2-9:** Example Write Script.

# MCP401XEV Evaluation Board User's Guide

Double clicking on the ReadAddrA8 Example I2CM Script will load the Script Details. Figure 2-10 shows what the values mean in the Script Details. These values are hex numbers.

The first value (02h) is the number of bytes that will be written. The second byte is the I<sup>2</sup>C Slave address (A8h) of the device with the Read/Write bit forced to '0' (an I<sup>2</sup>C write). The next byte (00h) is a data byte, and the value will be dependent on the slave I<sup>2</sup>C device protocol format and the desired operation.

Now a I<sup>2</sup>C Restart bit is forced onto the I<sup>2</sup>C bus. The next byte (01h) indicates how many bytes will be read. The next bit (A9h) is the I<sup>2</sup>C Slave address (A8h) of the device with the Read/Write bit forced to '1' (an I<sup>2</sup>C read). The last byte (10h) is the number of bytes that will be read from the I<sup>2</sup>C Slave Device. The value will be dependent on the slave I<sup>2</sup>C device protocol format and the desired operation.

The screenshot shows the 'Script Builder' window with the 'ReadAddrA8' script selected. The 'Script Detail' pane shows the following sequence of operations and values:

Operation	Value	Annotation
I2CSTART		
I2CWRTBYT	02	Number of Bytes that will be written
I2CWRTBYT	A8	I <sup>2</sup> C Slave Address + Read/Write bit (R/W bit = 0)
I2CWRTBYT	00	Data Byte #1 (1)
I2CRESTART		
I2CWRTBYT	01	Number of Bytes that will be written
I2CRDBYTNLB	A9	I <sup>2</sup> C Slave Address + Read/Write bit (R/W bit = 1)
I2CRDBYTNLB	10	# of Data Bytes to Read (1)
I2CSTOP		

**Note 1:** Function depends on devices I<sup>2</sup>C Protocol Format.

**FIGURE 2-10:** Example Read Script.



# Installation and Operation

To create the write script for the MCP40D18, double click on the WriteAddrA8 script in the “Example I2CM Scripts” column. This loads the script (see Figure 2-9) into the “Script Detail” column. Modify the script details so that it looks like Figure 2-11. Then, in the “Script Name” write the name that you would like to call the script. We chose “MCP40D18\_Write” (see Figure 2-11).

Then click on the “Save Script” button. This will save the script, which can then be accessed under the “User I2CM Scripts” column (see Figure 2-11). This script will be available when the GUI is opened in the future (unless the script has been cleared or deleted).

**Note:** The saved User Scripts are saved to a text file. The file is saved in the PICKit Serial Analyzer directory. This User Scripts file is called:  
CommScripts.txt  
The default install location of the file is:  
C:\Program Files\Microchip\PICKit Serial Analyzer

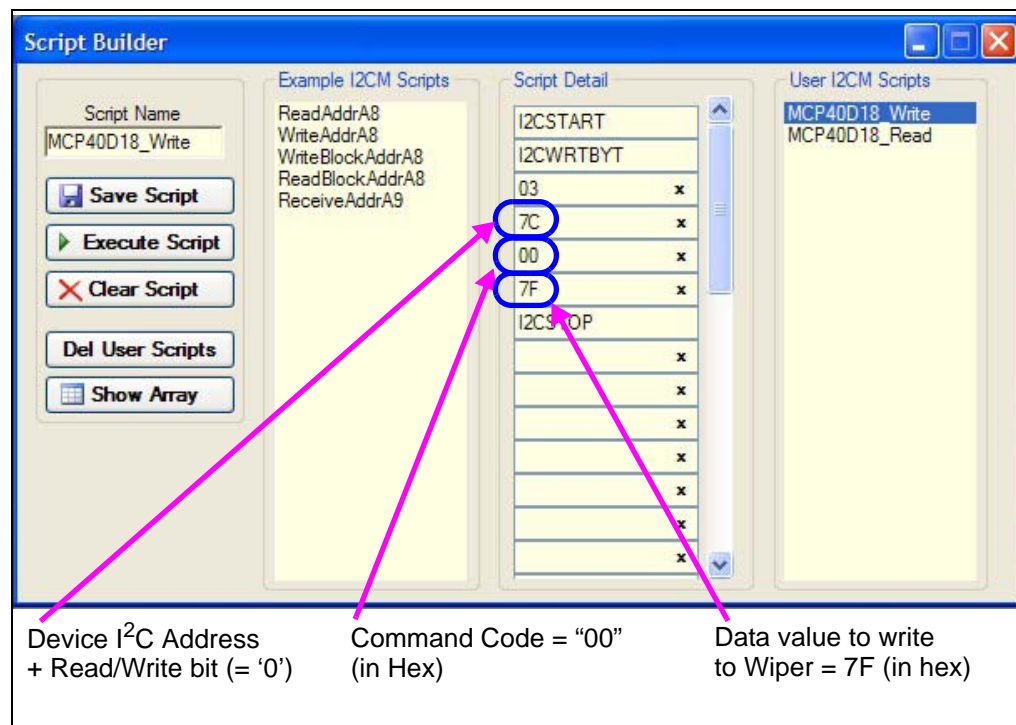

**FIGURE 2-11:** MCP40D18 Write Script File.

# MCP401XEV Evaluation Board User's Guide

To create the read script for the MCP40D18, double click on the ReadAddrA8 script in the “Example I2CM Scripts” column. This loads the script (see Figure 2-10) into the “Script Detail” column. Modify the script details so that it looks like Figure 2-12. Then, in the “Script Name” write the name that you would like to call the script. We chose “MCP40D18\_Read” (see Figure 2-12).

Then click on the “Save Script” button. This will save the script, which can then be accessed under the “User I2CM Script” column (see Figure 2-11). This script will be available when the GUI is opened in the future (unless the script has been cleared or deleted).

**Note:** The saved User Scripts are saved to a text file. The file is saved in the PICKit Serial Analyzer directory. This User Scripts file is called: CommScripts.txt  
The default install location of the file is:  
C:\Program Files\Microchip\PICKit Serial Analyzer

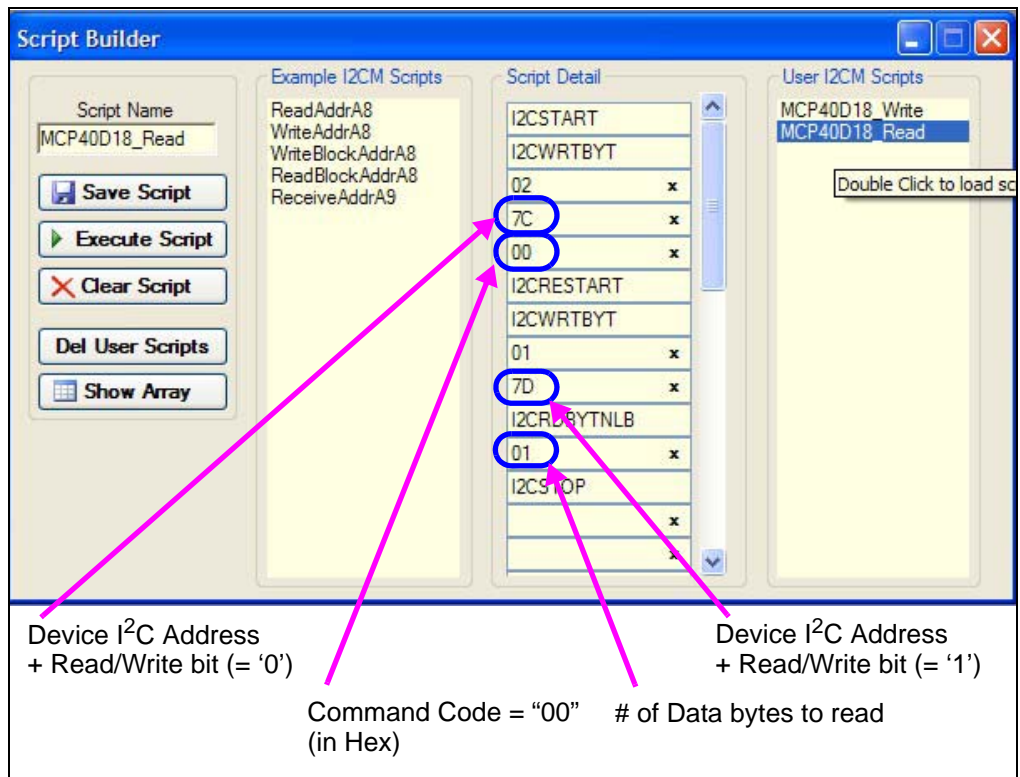

**FIGURE 2-12:** MCP40D18 Read Script File.

## 2.6 MCP40D18EV DEMO STEPS

This demo assumes that you know how to configure the PICKit Serial Analyzer for Master I<sup>2</sup>C operation. See **Section 2.5 “Configuring The PICKit Serial Analyzer”** or the PICKit Serial Analyzer User’s Guide (DS51647) for additional information.

1. Plug the PICKit Serial device into the PC’s USB port.
2. Plug the MCP40D18EV board into the PICKit Serial.
3. Start the PICKit Serial GUI.
4. Ensure the GUI is in Master I<sup>2</sup>C communication mode (see Figure 2-4).
5. Ensure that the Master I<sup>2</sup>C configuration is appropriately configured (see Figure 2-6).
6. Measure the wiper voltage on the MCP40D18EV board using an oscilloscope or digital multimeter. Measure voltage from the ground plane (GND) to the Wiper (P7). The voltage on the wiper should be  $\sim V_{DD}/2$  ( $\sim 2.5V$ ).
7. Open the Script Builder window (see Figure 2-7).
8. Double click on the “WriteAddrA8” script in the “Example I2CM Scripts column. This loads the Script Detail column (see Figure 2-9).
9. Modify the “Script Detail” so that it is like that shown in Figure 2-13.
10. Click on the “Execute Script” button. This executes the script shown in the script detail column, which will update the wiper value to 7Fh. The Wiper voltage will now be  $\sim V_{DD}$  ( $\sim 5V$ ). The Transaction window (see Figure 2-15) will be updated to indicate the execution of the script.
11. Select the “MCP40D18\_Read” script in the User I2CM Scripts column. It should look like Figure 2-14.
12. Click on the “Execute Script” button. This executes the script shown in the script detail column. The Transaction window (see Figure 2-15) will be updated to indicate the execution of the script. The Data read is shown in the last line.
13. Select the “MCP40D18\_Write” script in the User I2CM Scripts column. It should look like Figure 2-13.
14. Modify the data value to write to the wiper (see Figure 2-13) to 1Fh.
15. Click on the “Execute Script” button. This executes the script shown in the script detail column, which will update the wiper value to 1Fh (from 7Fh). The Wiper voltage will now be  $\sim 1/4 * V_{DD}$  ( $\sim 1.25V$ ). The Transaction window (see Figure 2-16) will be updated to indicate the execution of the script.
16. Select the “MCP40D18\_Read” script in the User I2CM Scripts column. It should look like Figure 2-14.
17. Click on the “Execute Script” button. This executes the script shown in the script detail column. The Transaction window (see Figure 2-16) will be updated to indicate the execution of the script. The Data read is shown in the last line.
18. You can repeat the sequence of writing values to the wiper register or Writing then reading the values back.

### NOTICE

**If at any time during script execution, an error message is generated in the transaction window, it is good practice to reset the PICKit Serial Analyzer (PKSA). The PKSA can be reset using the “Reset” toolbar icon. Verify that subsequent script operations do not generate errors.**

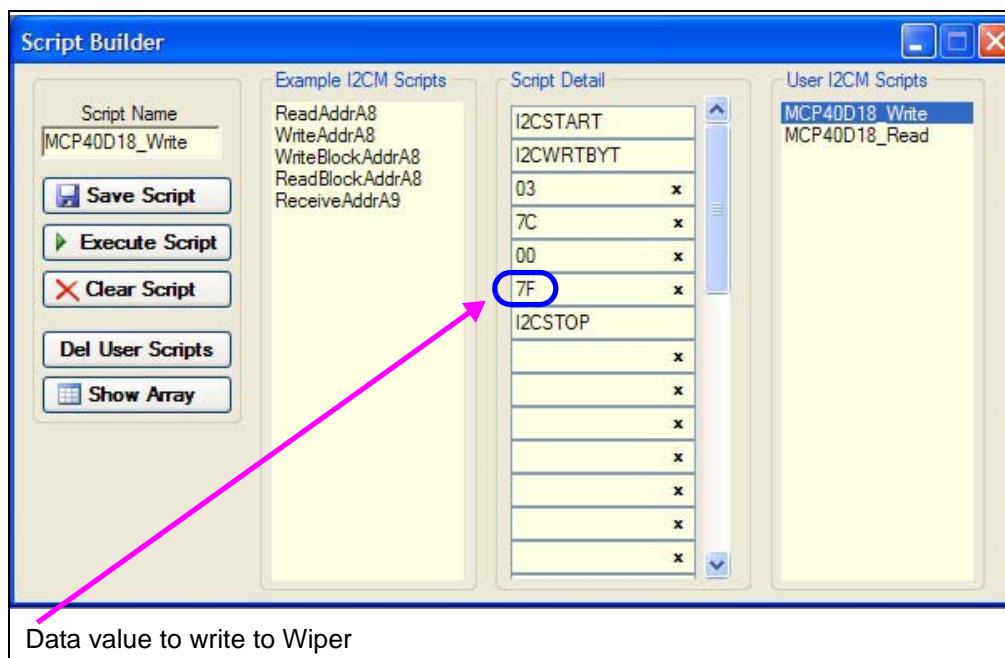

FIGURE 2-13: MCP40D18 Write Script File - Updating Wiper Value.

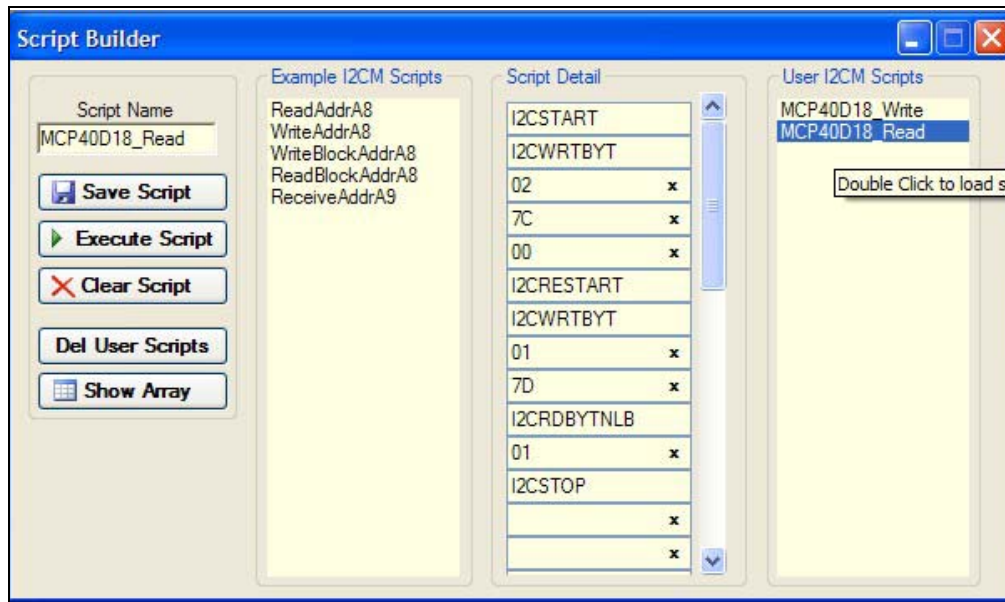
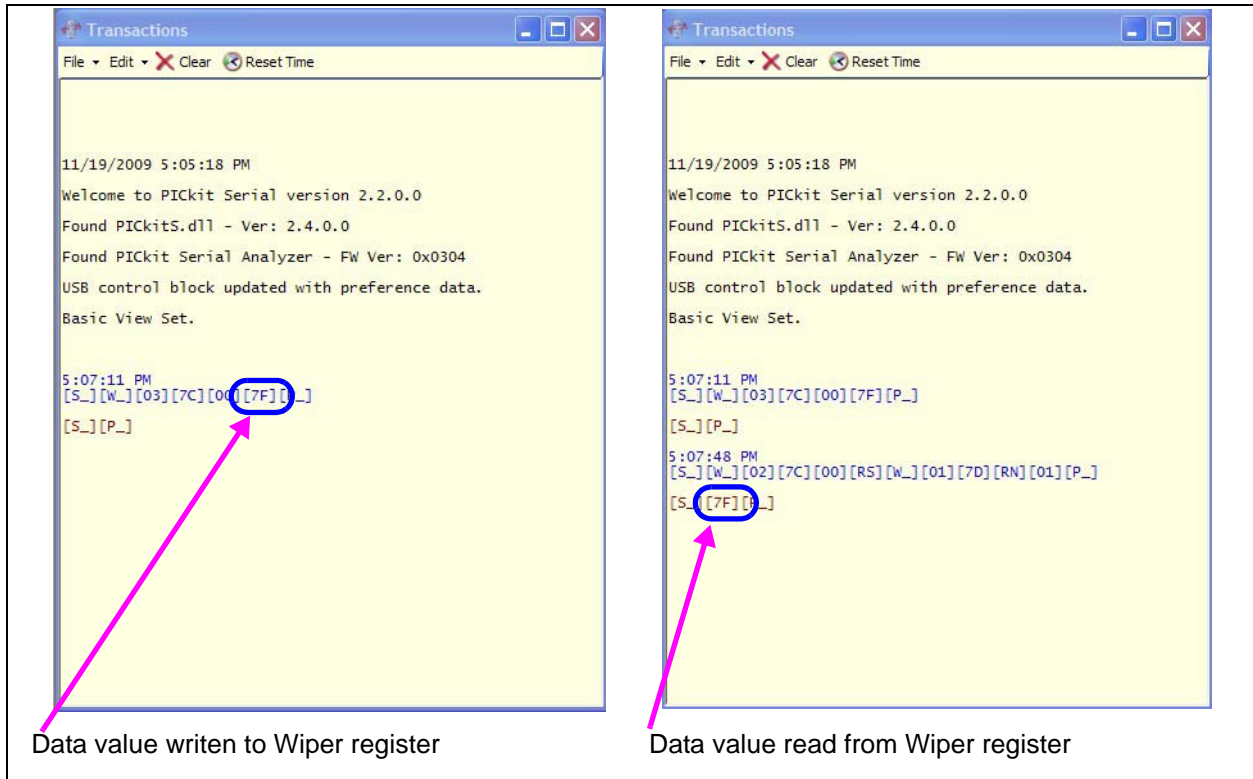
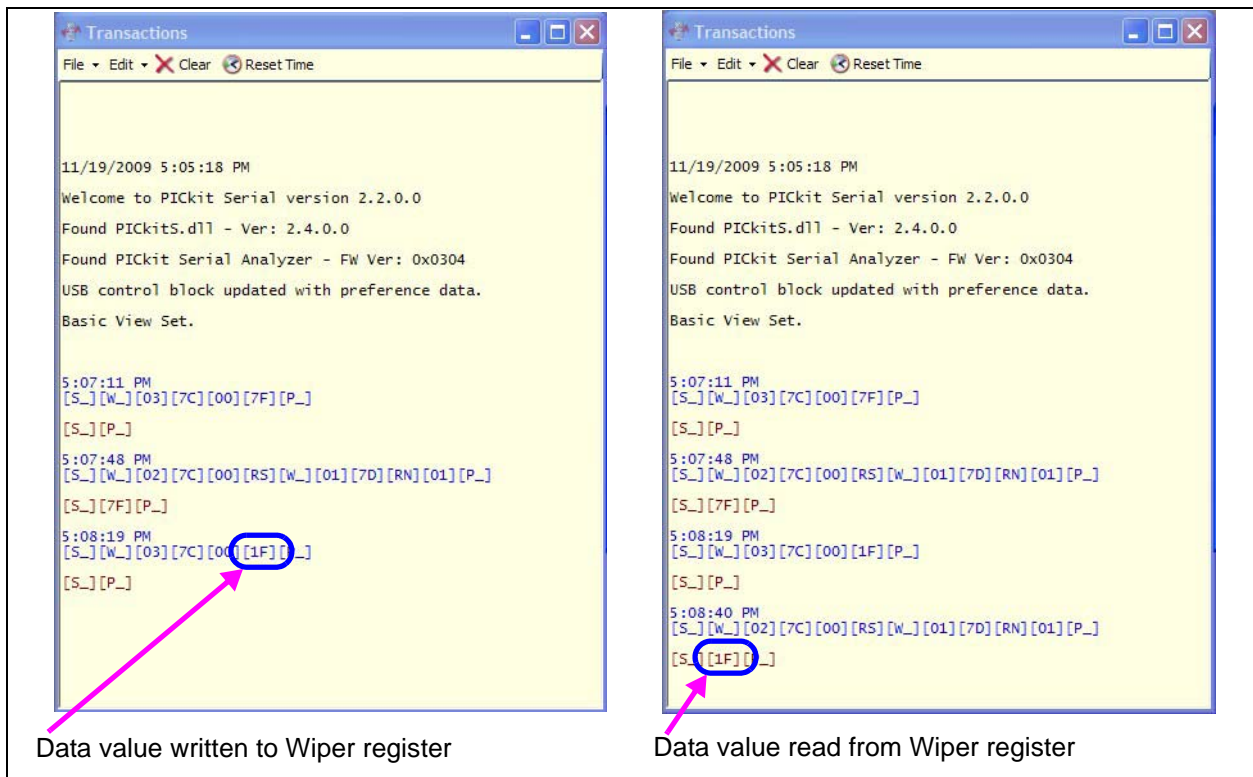

FIGURE 2-14: MCP40D18 Read Script File.

# Installation and Operation



**FIGURE 2-15:**      *MCP40D18 Transaction Windows 1 and 2.*



**FIGURE 2-16:**      *MCP40D18 Transaction Windows 3 and 4.*

## 2.6.1 The SC70EV PCB and Supported Digital Potentiometers

Table 2-3 shows the current Digital Potentiometers that are supported by the SC70EV PCB.

**TABLE 2-3: SC70EV PCB SUPPORTED DIGITAL POTENTIOMETERS**

Device	SC70	SOT-23	DIP	Comment
MCP4012	—	Yes	—	SOT-23-6, uses Up/Down interface
MCP4013	—	Yes	—	SOT-23-6, uses Up/Down interface
MCP4014	—	Yes	—	SOT-23-5, uses Up/Down interface
MCP4017	Yes	—	—	
MCP40D17	Yes	—	—	
MCP4018	Yes	—	—	
MCP40D18	Yes	—	—	
MCP4019	Yes	—	—	
MCP40D19	Yes	—	—	
MCP4022	—	Yes	—	SOT-23-6, uses Up/Down interface
MCP4023	—	Yes	—	SOT-23-6, uses Up/Down interface
MCP4024	—	Yes	—	SOT-23-5, uses Up/Down interface
MCP4131	—	—	Yes	Has multiplexed SDI/SDO
MCP4132	—	—	Yes	
MCP4141	—	—	Yes	Has multiplexed SDI/SDO
MCP4142	—	—	Yes	
MCP4151	—	—	Yes	Has multiplexed SDI/SDO
MCP4152	—	—	Yes	
MCP4161	—	—	Yes	Has multiplexed SDI/SDO
MCP4162	—	—	Yes	
MCP41010	—	—	Yes	
MCP41050	—	—	Yes	
MCP41100	—	—	Yes	

---

---

## Appendix A. Schematic and Layouts

---

---

### A.1 INTRODUCTION

This appendix contains the schematics and layouts for the MCP401XEV Evaluation Board. Diagrams included in this appendix:

- Board - Schematic
- Board - Top Trace, Silk and Pads
- Board - Bottom Trace & Pads
- Board - Layer 2 Ground Plane
- Board - Layer 3 Power Plane
- Board - Bottom Silk, Trace and Pads

### A.2 SCHEMATICS AND PCB LAYOUT

Board - Schematic shows the schematic of the MCP401XEV Evaluation Board. The layer order is shown in Figure A-1.

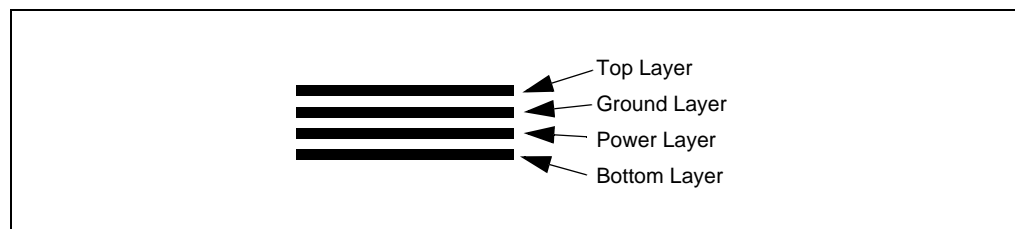

**FIGURE A-1:** *Layer Order.*

## A.3 BOARD - SCHEMATIC

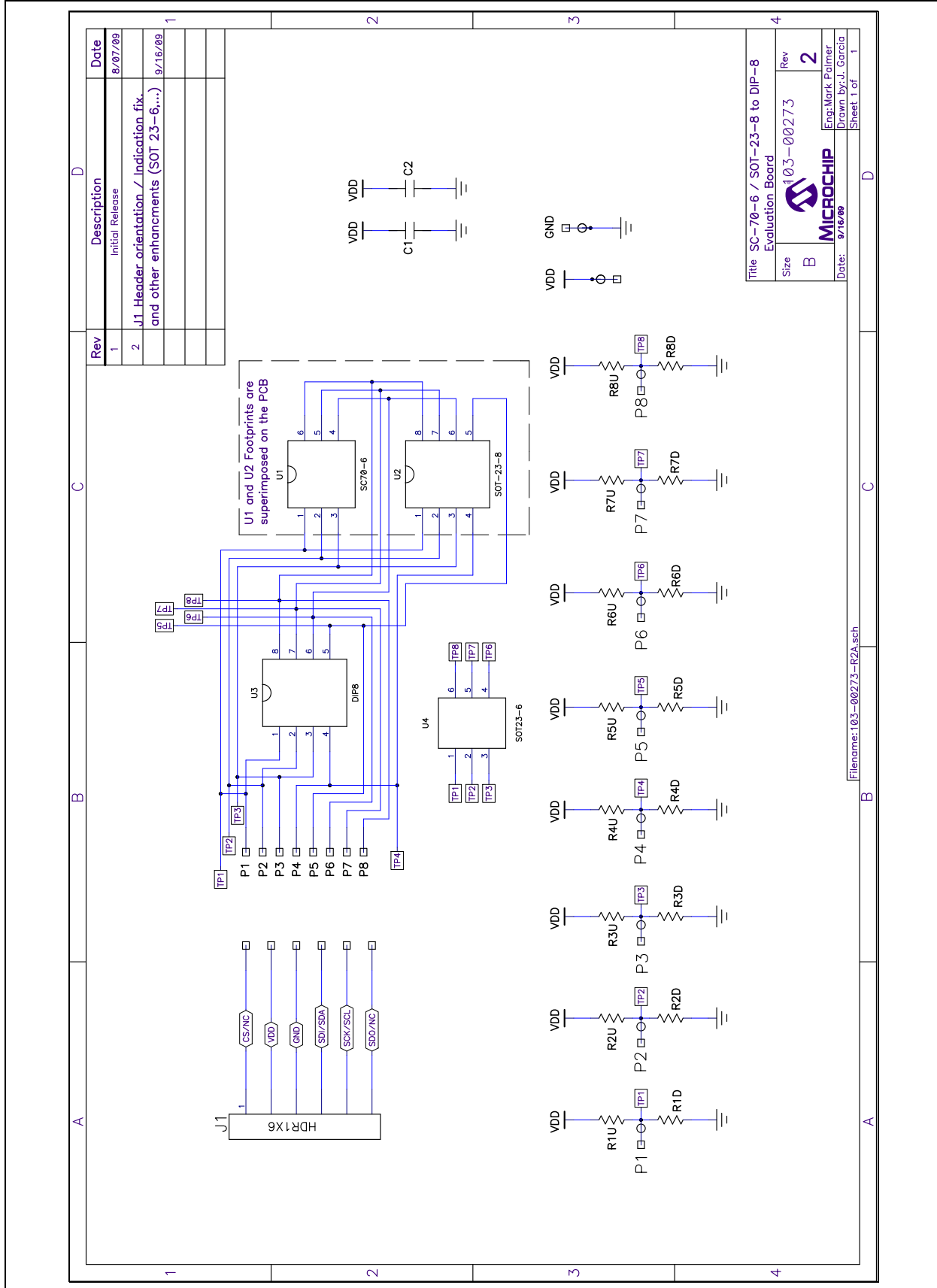



## A.4 BOARD - TOP TRACE, SILK AND PADS

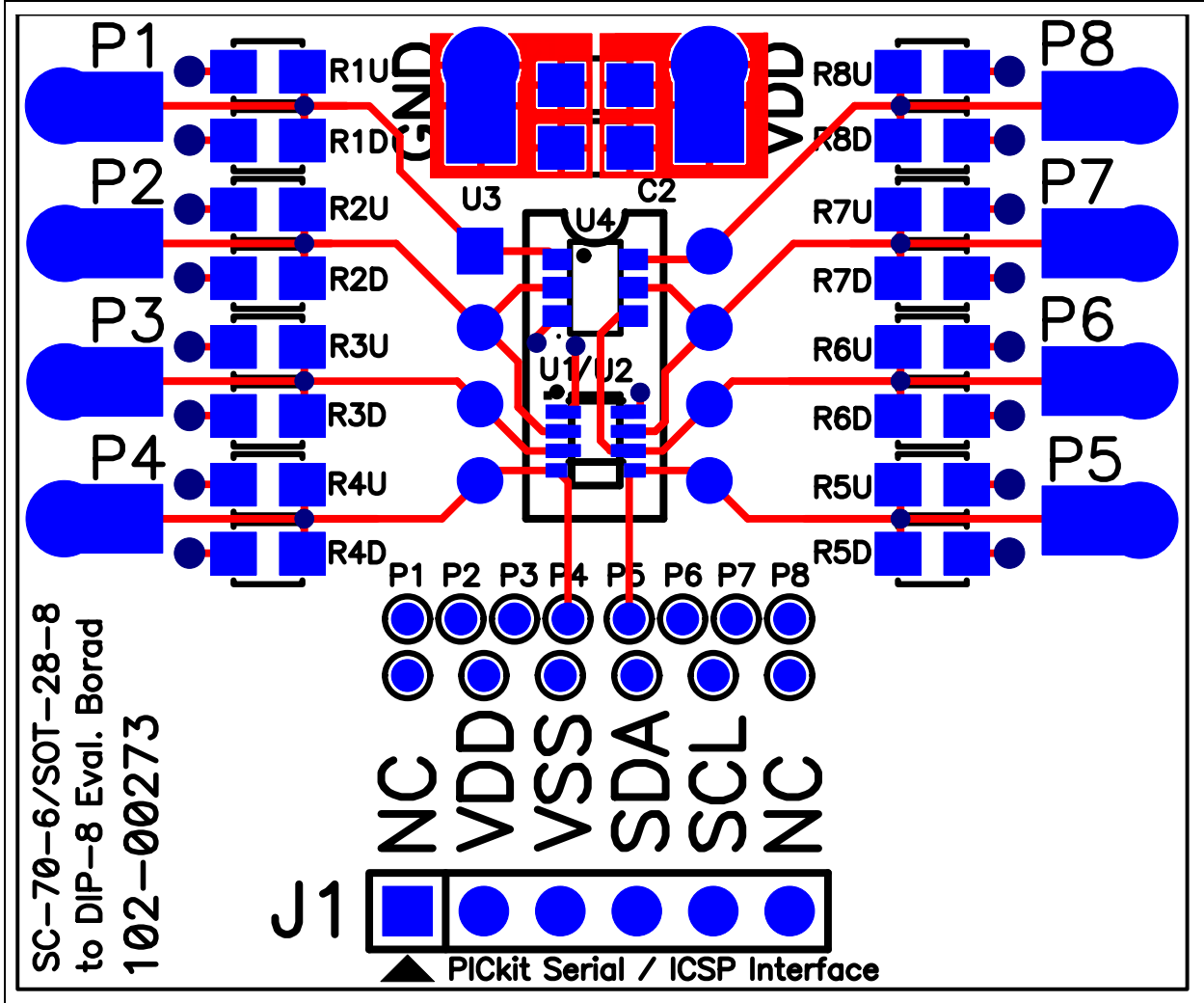

A.5 BOARD - BOTTOM TRACE & PADS

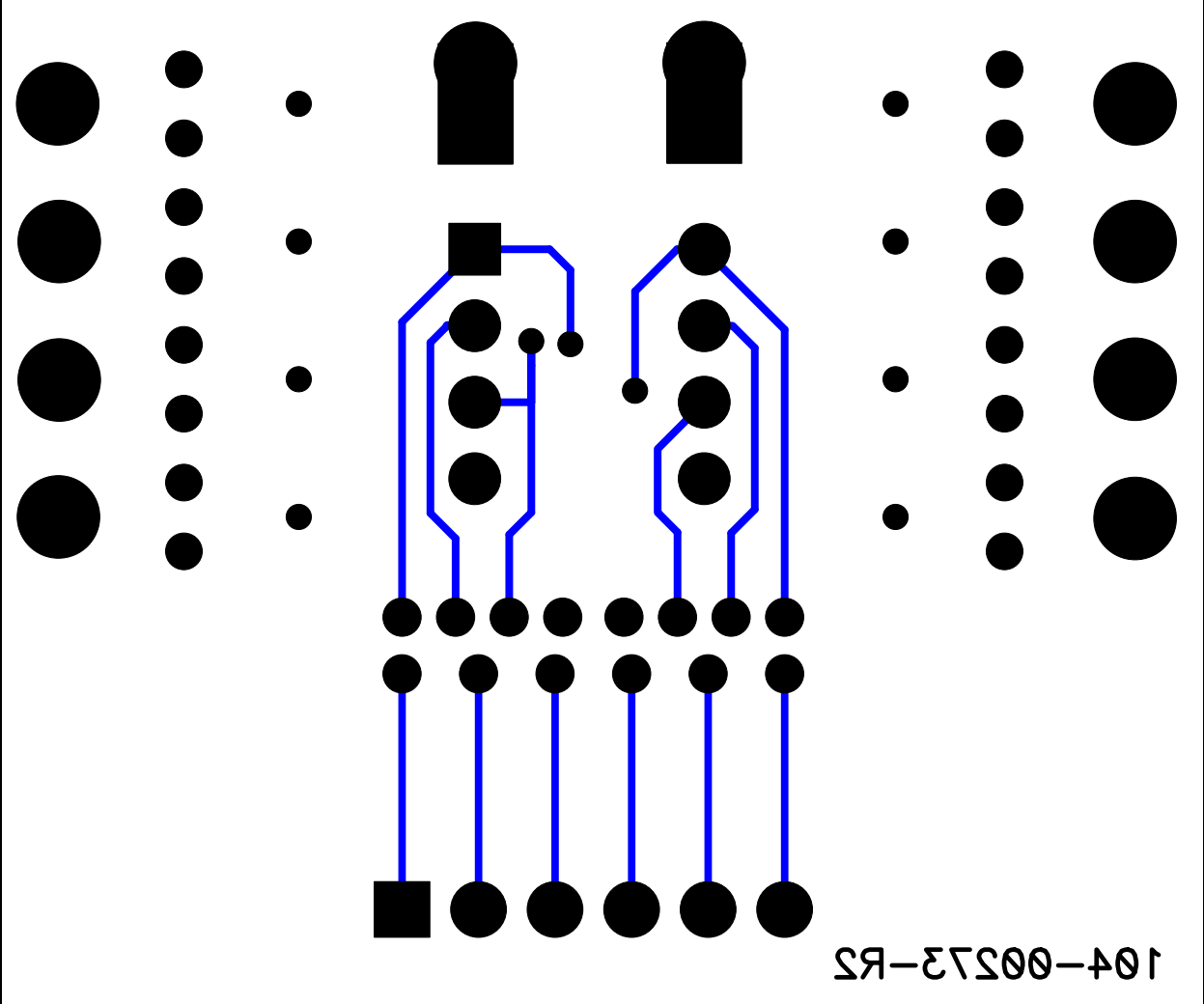

## A.6 BOARD - LAYER 2 GROUND PLANE

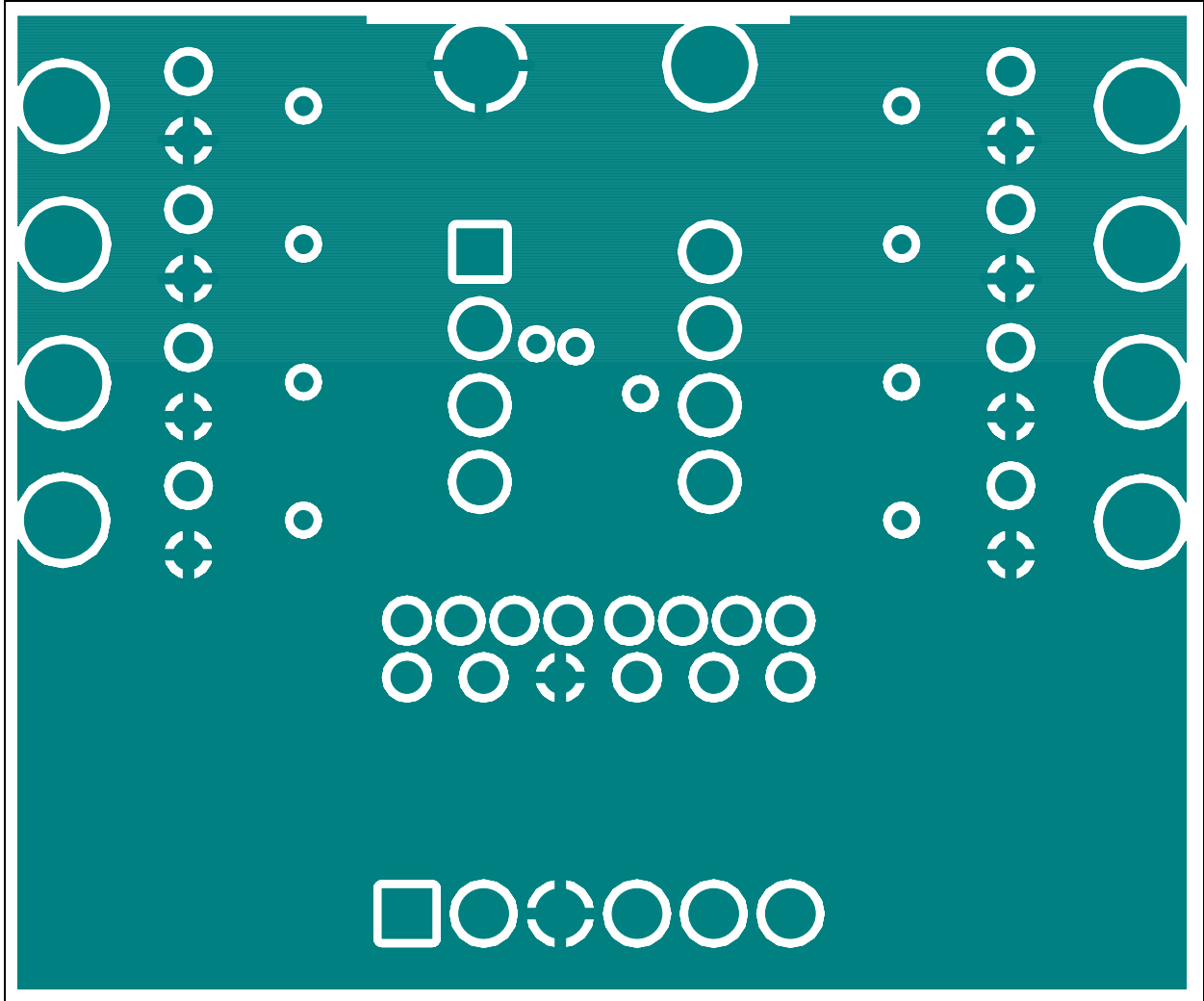

## A.7 BOARD - LAYER 3 POWER PLANE

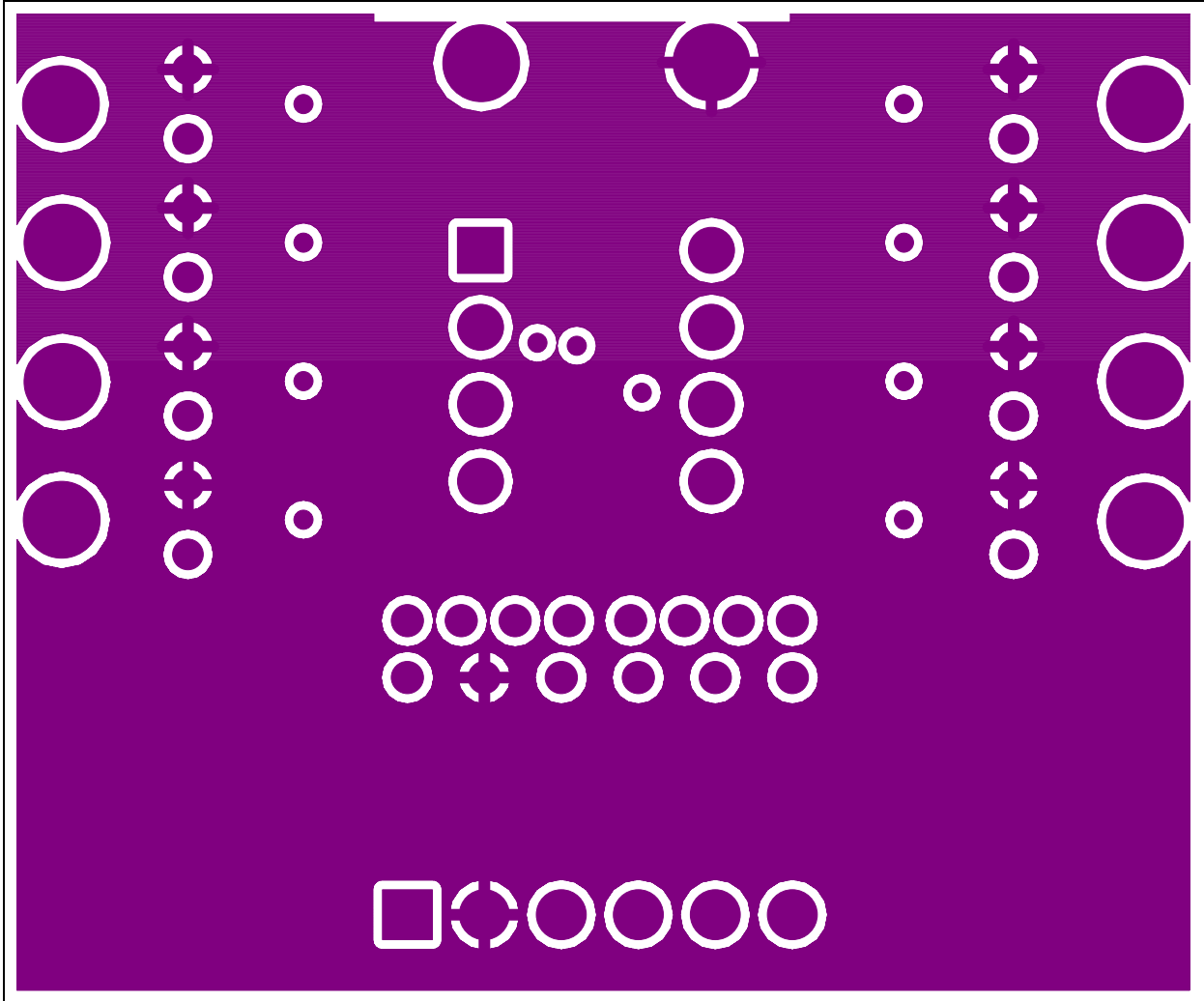

## A.8 BOARD - BOTTOM SILK, TRACE AND PADS

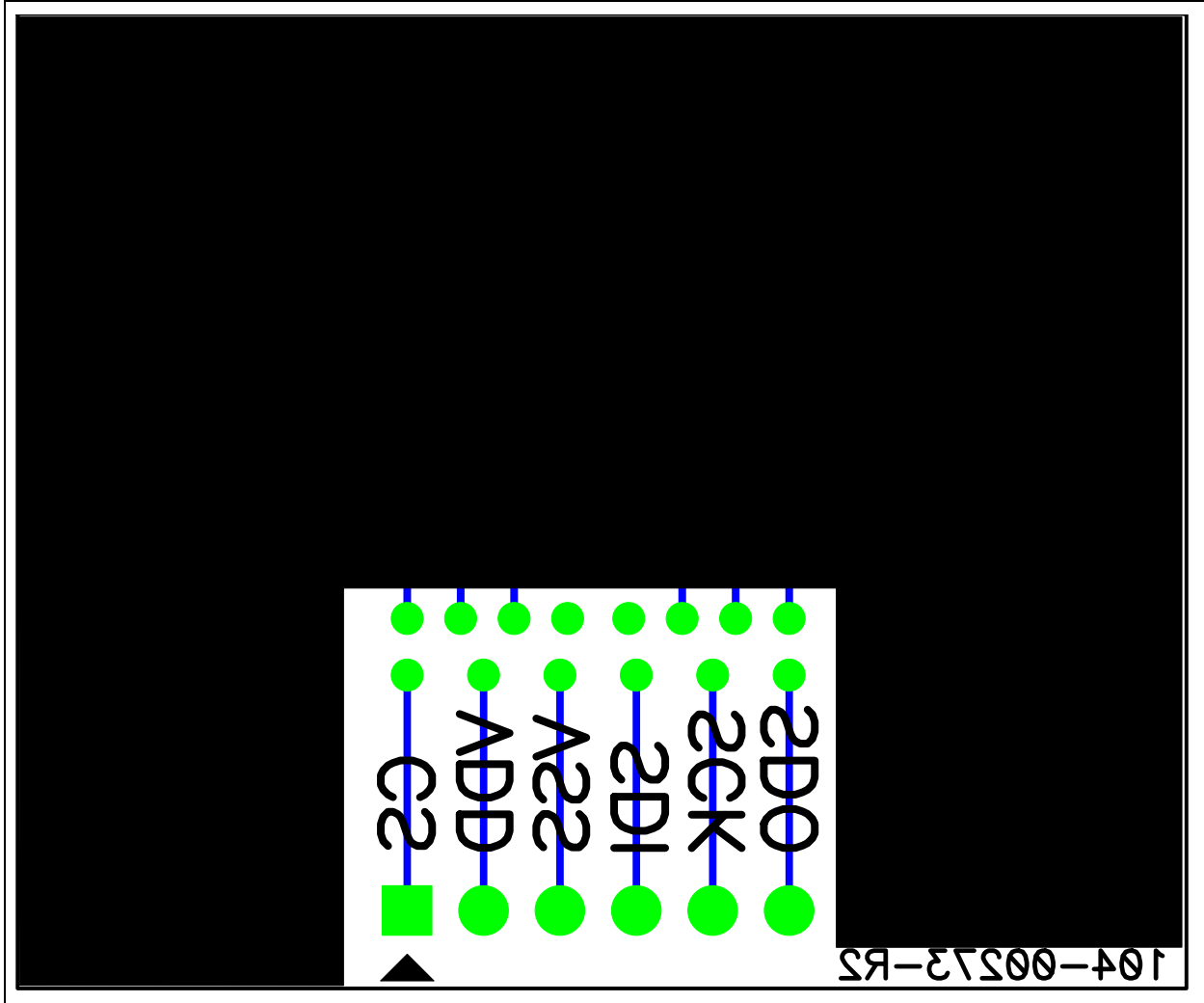

NOTES:

**Appendix B. Bill of Materials (BOM)**

**TABLE B-1: BILL OF MATERIALS**

Qty	Reference	Description	Manufacturer	Part Number
1	J1	CONN HEADER 6POS .100 R/A GOLD	Molex/Waldom Electronics Corp	22-28-8062
1	P7	TEST POINT PC MULTI PURPOSE ORG	Keystone Electronics®	5013
2	PCB	<b>Note 1</b>	Microchip Technology Inc.	104-00273 ( <b>Note 3</b> )
3	R1U, R8U, R2D	RES 0.0 OHM 1/8W 5% 0805 SMD	Panasonic® - ECG	ERJ-6GEY0R00V
1	U1	7-Bit Single I2C™ (with Command Code) Digital POT with Volatile Memory in SC70	Microchip Technology Inc.	MCP40D18-103AE/LT
1	—	Blue Wire: J1 SCL via to P3 via J1 SDA via to P6 via	See Figure 2-2	—

- Note 1:** This assembly uses RoHS Compliant SC70-6 and SOT-23-6/8 to DIP-8 Evaluation Board.
- 2:** The components listed in this Bill of Materials are representative of the PCB assembly. The released BOM used in manufacturing uses all RoHS-compliant components.
- 3:** This part number is an internal Microchip number; if a customer wants to order, the SC70EV order number needs to be used.



## WORLDWIDE SALES AND SERVICE

### AMERICAS

#### Corporate Office

2355 West Chandler Blvd.  
Chandler, AZ 85224-6199  
Tel: 480-792-7200  
Fax: 480-792-7277  
Technical Support:  
<http://support.microchip.com>  
Web Address:  
[www.microchip.com](http://www.microchip.com)

#### Atlanta

Duluth, GA  
Tel: 678-957-9614  
Fax: 678-957-1455

#### Boston

Westborough, MA  
Tel: 774-760-0087  
Fax: 774-760-0088

#### Chicago

Itasca, IL  
Tel: 630-285-0071  
Fax: 630-285-0075

#### Cleveland

Independence, OH  
Tel: 216-447-0464  
Fax: 216-447-0643

#### Dallas

Addison, TX  
Tel: 972-818-7423  
Fax: 972-818-2924

#### Detroit

Farmington Hills, MI  
Tel: 248-538-2250  
Fax: 248-538-2260

#### Kokomo

Kokomo, IN  
Tel: 765-864-8360  
Fax: 765-864-8387

#### Los Angeles

Mission Viejo, CA  
Tel: 949-462-9523  
Fax: 949-462-9608

#### Santa Clara

Santa Clara, CA  
Tel: 408-961-6444  
Fax: 408-961-6445

#### Toronto

Mississauga, Ontario,  
Canada  
Tel: 905-673-0699  
Fax: 905-673-6509

### ASIA/PACIFIC

#### Asia Pacific Office

Suites 3707-14, 37th Floor  
Tower 6, The Gateway  
Harbour City, Kowloon  
Hong Kong  
Tel: 852-2401-1200  
Fax: 852-2401-3431

#### Australia - Sydney

Tel: 61-2-9868-6733  
Fax: 61-2-9868-6755

#### China - Beijing

Tel: 86-10-8528-2100  
Fax: 86-10-8528-2104

#### China - Chengdu

Tel: 86-28-8665-5511  
Fax: 86-28-8665-7889

#### China - Chongqing

Tel: 86-23-8980-9588  
Fax: 86-23-8980-9500

#### China - Hong Kong SAR

Tel: 852-2401-1200  
Fax: 852-2401-3431

#### China - Nanjing

Tel: 86-25-8473-2460  
Fax: 86-25-8473-2470

#### China - Qingdao

Tel: 86-532-8502-7355  
Fax: 86-532-8502-7205

#### China - Shanghai

Tel: 86-21-5407-5533  
Fax: 86-21-5407-5066

#### China - Shenyang

Tel: 86-24-2334-2829  
Fax: 86-24-2334-2393

#### China - Shenzhen

Tel: 86-755-8203-2660  
Fax: 86-755-8203-1760

#### China - Wuhan

Tel: 86-27-5980-5300  
Fax: 86-27-5980-5118

#### China - Xian

Tel: 86-29-8833-7252  
Fax: 86-29-8833-7256

#### China - Xiamen

Tel: 86-592-2388138  
Fax: 86-592-2388130

#### China - Zhuhai

Tel: 86-756-3210040  
Fax: 86-756-3210049

### ASIA/PACIFIC

#### India - Bangalore

Tel: 91-80-3090-4444  
Fax: 91-80-3090-4080

#### India - New Delhi

Tel: 91-11-4160-8631  
Fax: 91-11-4160-8632

#### India - Pune

Tel: 91-20-2566-1512  
Fax: 91-20-2566-1513

#### Japan - Yokohama

Tel: 81-45-471- 6166  
Fax: 81-45-471-6122

#### Korea - Daegu

Tel: 82-53-744-4301  
Fax: 82-53-744-4302

#### Korea - Seoul

Tel: 82-2-554-7200  
Fax: 82-2-558-5932 or  
82-2-558-5934

#### Malaysia - Kuala Lumpur

Tel: 60-3-6201-9857  
Fax: 60-3-6201-9859

#### Malaysia - Penang

Tel: 60-4-227-8870  
Fax: 60-4-227-4068

#### Philippines - Manila

Tel: 63-2-634-9065  
Fax: 63-2-634-9069

#### Singapore

Tel: 65-6334-8870  
Fax: 65-6334-8850

#### Taiwan - Hsin Chu

Tel: 886-3-6578-300  
Fax: 886-3-6578-370

#### Taiwan - Kaohsiung

Tel: 886-7-536-4818  
Fax: 886-7-536-4803

#### Taiwan - Taipei

Tel: 886-2-2500-6610  
Fax: 886-2-2508-0102

#### Thailand - Bangkok

Tel: 66-2-694-1351  
Fax: 66-2-694-1350

### EUROPE

#### Austria - Wels

Tel: 43-7242-2244-39  
Fax: 43-7242-2244-393

#### Denmark - Copenhagen

Tel: 45-4450-2828  
Fax: 45-4485-2829

#### France - Paris

Tel: 33-1-69-53-63-20  
Fax: 33-1-69-30-90-79

#### Germany - Munich

Tel: 49-89-627-144-0  
Fax: 49-89-627-144-44

#### Italy - Milan

Tel: 39-0331-742611  
Fax: 39-0331-466781

#### Netherlands - Drunen

Tel: 31-416-690399  
Fax: 31-416-690340

#### Spain - Madrid

Tel: 34-91-708-08-90  
Fax: 34-91-708-08-91

#### UK - Wokingham

Tel: 44-118-921-5869  
Fax: 44-118-921-5820

12/30/09





## Стандарт Электрон Связь

Мы молодая и активно развивающаяся компания в области поставок электронных компонентов. Мы поставляем электронные компоненты отечественного и импортного производства напрямую от производителей и с крупнейших складов мира.

Благодаря сотрудничеству с мировыми поставщиками мы осуществляем комплексные и плановые поставки широчайшего спектра электронных компонентов.

Собственная эффективная логистика и склад в обеспечивает надежную поставку продукции в точно указанные сроки по всей России.

Мы осуществляем техническую поддержку нашим клиентам и предпродажную проверку качества продукции. На все поставляемые продукты мы предоставляем гарантию .

Осуществляем поставки продукции под контролем ВП МО РФ на предприятия военно-промышленного комплекса России , а также работаем в рамках 275 ФЗ с открытием отдельных счетов в уполномоченном банке. Система менеджмента качества компании соответствует требованиям ГОСТ ISO 9001.

Минимальные сроки поставки, гибкие цены, неограниченный ассортимент и индивидуальный подход к клиентам являются основой для выстраивания долгосрочного и эффективного сотрудничества с предприятиями радиоэлектронной промышленности, предприятиями ВПК и научно-исследовательскими институтами России.

С нами вы становитесь еще успешнее!

### Наши контакты:

**Телефон:** +7 812 627 14 35

**Электронная почта:** [sales@st-electron.ru](mailto:sales@st-electron.ru)

**Адрес:** 198099, Санкт-Петербург,  
Промышленная ул, дом № 19, литера Н,  
помещение 100-Н Офис 331