

### Features

- High Output Current Up to 1.5A
- Low Feedback Voltage:0.1V
- Stable with a Ceramic Output Capacitor
- Low Quiescent Current
- Open Load LED Protection
- Over Temperature Shutdown
- Low Temperature Coefficient
- Standard SOP-8(EP) Packages
- Pb-Free Package

### Applications

- High Bright LED Driver
- White LED Torch (Flashlight)

### General Description

The PAM2808 is a 5W high power HBLED driver with 1.5A constant current. It features high efficiency and low quiescent current, making it ideal for battery powered applications.

The PAM2808 features over current protection and over temperature shutdown. The PAM2808 is stable with a ceramic output capacitor of 4.7 $\mu$ F or higher.

PAM2808 is available in SOP-8(EP) package.

### Typical Application Circuit

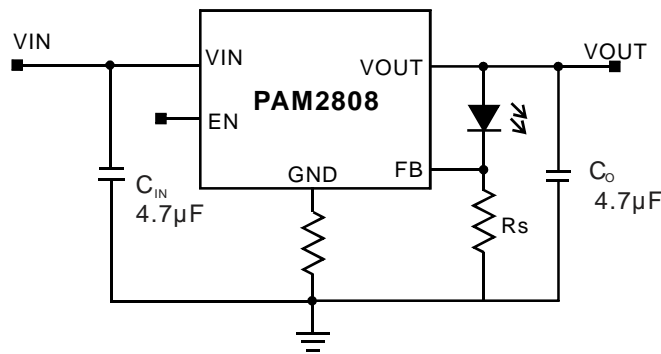

### Block Diagram

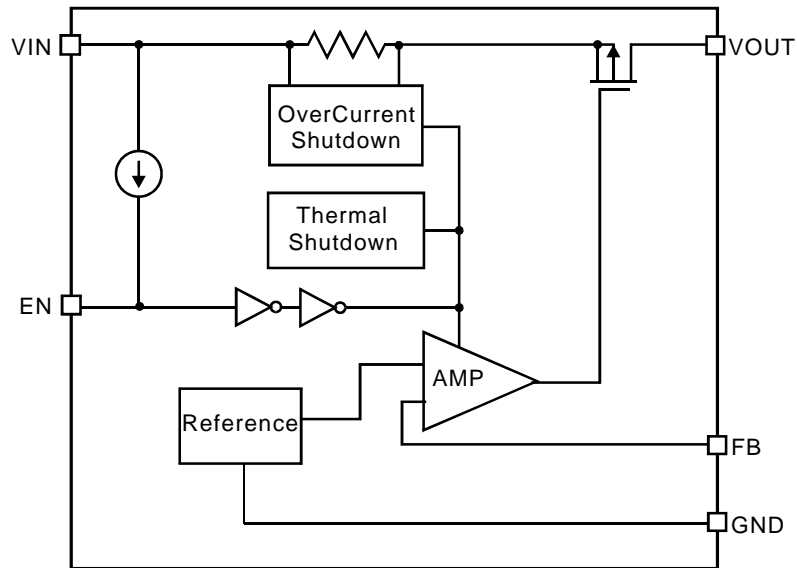

### Pin Configuration & Marking Information

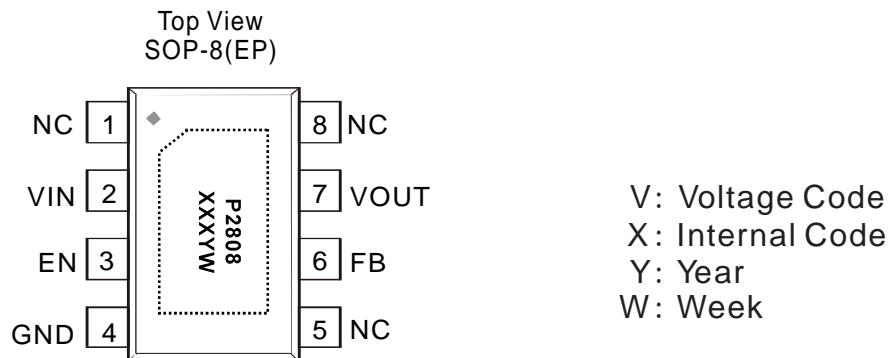



### Absolute Maximum Ratings

These are stress ratings only and functional operation is not implied. Exposure to absolute maximum ratings for prolonged time periods may affect device reliability. All voltages are with respect to ground.

Input Voltage.....6.5V	Storage Temperature.....-65°C to 150°C
EN, FB, VOUT Pin Voltage	Maximum Junction Temperature.....150°C
.....-0.3V to $V_{IN}+0.3V$	Lead Soldering Temperature (5sec)..... 300°C
Maximum Output Current..... $P_D/(V_{IN}-V_O)$	

### Recommended Operating Conditions

Maximum Supply Voltage.....6V	Junction Temperature Range.....-40°C to 125°C
	Ambient Temperature Range.....-40°C to 85°C

### Thermal Information

Parameter	Symbol	Package	Maximum	Unit
Thermal Resistance (Junction to Case)	$\theta_{JC}$	SOP-8(EP)	11	°C/W
Thermal Resistance (Junction to Ambient)	$\theta_{JA}$	SOP-8(EP)	90	°C/W



### Electrical Characteristic

$V_{IN}=4.5V$ ,  $T_A=25^{\circ}C$ ,  $C_{IN}=4.7\mu F$ ,  $C_O=4.7\mu F$ , unless otherwise noted.

PARAMETER	SYMBOL	Test Conditions	MIN	TYP	MAX	UNITS
Input Voltage	$V_{IN}$		2.5		6.0	V
FB Reference Voltage	$V_{REF}$			0.1		V
Output Current	$I_O$	$R_S=0.3\Omega$		330		mA
		$R_S=0.14\Omega$		700		
		$R_S=0.1\Omega$		1000		
		$R_S=0.067\Omega$		1500		
Over Temperature Shutdown	OTS			150		$^{\circ}C$
Over Temperature Hysteresis	OTH			40		$^{\circ}C$
EN Input High Threshold	$V_{EH}$	$V_{IN}=2.5V$ to 5V	1.5			V
EN Input Low Threshold	$V_{EL}$	$V_{IN}=2.5V$ to 5V			0.3	V
Shutdown Current	$I_{SD}$	$V_{EN}=0V$			1	$\mu A$

### Typical Performance Characteristics

$T_A=25^{\circ}\text{C}$ ,  $C_{IN}=4.7\mu\text{F}$ ,  $C_O=4.7\mu\text{F}$ , unless otherwise noted.

1. LED Current vs Input Voltage

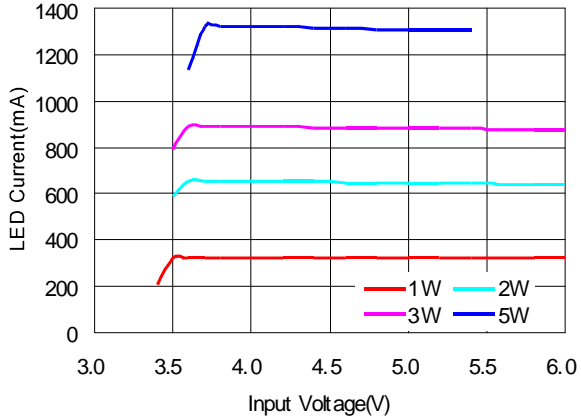

2. Feedback Voltage vs Input Voltage

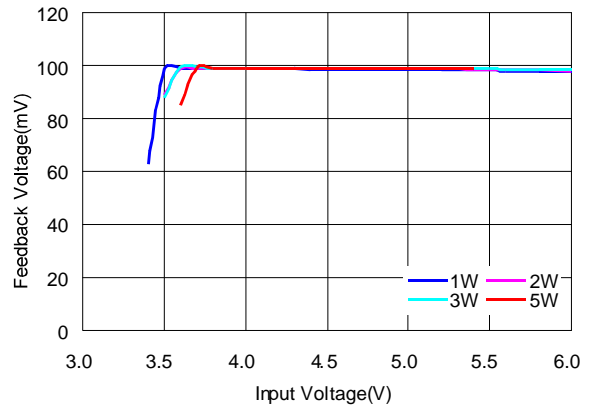

3. Dropout Voltage vs LED Current

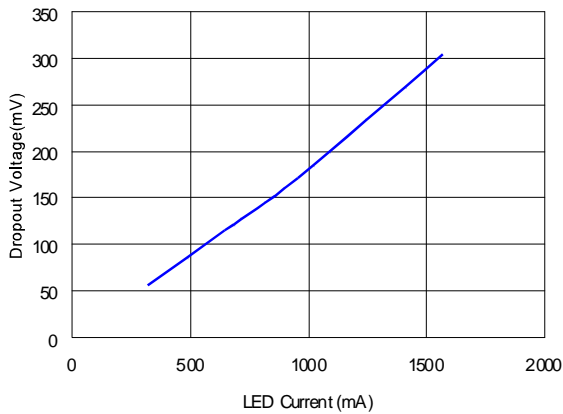

4. Start up

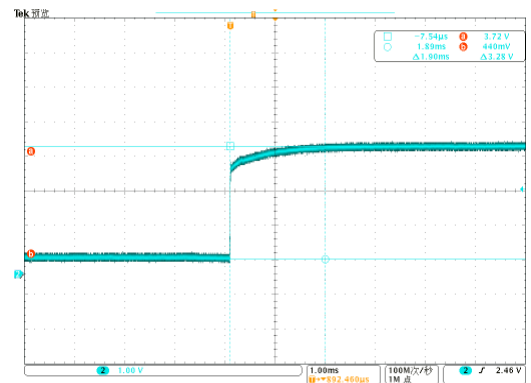

## Application Information

### External Capacitor Requirements

A 4.7µF or larger ceramic input bypass capacitor, connected between  $V_{IN}$  and GND and located close to the PAM2808, is required for stability. A 4.7µF minimum value capacitor from  $V_O$  to GND is also required. To improve transient response, noise rejection, and ripple rejection, an additional 10µF or larger, low ESR capacitor is recommended at the output. A higher-value, low ESR output capacitor may be necessary if large, fast-rise-time load transients are anticipated and the device is located several inches from the power source, especially if the minimum input voltage of 2.5 V is used.

### Regulator Protection

The PAM2808 features internal current limiting, thermal protection and short circuit protection. During normal operation, the PAM2808 limits output current to about 2.5A. When current limiting engages, the output voltage scales back linearly until the over current condition ends. While current limiting is designed to prevent gross device failure, care should be taken not to exceed the power dissipation ratings of the package. If the temperature of the device exceeds 150°C, thermal-protection circuitry will shut down. Once the device has cooled down to approximately 40°C below the high temp trip point, regulator operation resumes.

### Thermal Information

The amount of heat generates is:

$$P_D = (V_{IN} - V_O) I_O$$

All integrated circuits have a maximum allowable junction temperature ( $T_J$  max) above which normal operation is not assured. A system designer must design the operating environment so that the operating junction temperature ( $T_J$ ) does not exceed the maximum junction temperature ( $T_J$  max). The two main environmental variables that a designer can use to improve thermal performance are air flow and external heatsinks. The purpose of this information is to aid the designer in determining the proper operating environment for a linear regulator that is operating at a specific power level.

In general, the maximum expected power ( $P_D(\max)$ ) consumed by a linear regulator is computed as:

$$P_{D\max} = (V_{I(\text{avg})} - V_{O(\text{avg})}) \times I_{O(\text{avg})} + V_{I(\text{avg})} \times I_{(Q)}$$

Where:

- $V_{I(\text{avg})}$  is the average input voltage.
- $V_{O(\text{avg})}$  is the average output voltage.
- $I_{O(\text{avg})}$  is the average output current.
- $I_{(Q)}$  is the quiescent current.

The quiescent current is insignificant compared to the average output current; therefore, the term  $V_{I(\text{avg})} \times I_{(Q)}$  can be neglected. The operating junction temperature is computed by adding the ambient temperature ( $T_A$ ) and the increase in temperature due to the regulator's power dissipation. The temperature rise is computed by multiplying the maximum expected power dissipation by the sum of the thermal resistances between the junction and the case ( $R_{\theta JC}$ ), the case to heatsink ( $R_{\theta CS}$ ), and the heatsink to ambient ( $R_{\theta SA}$ ). Thermal resistances are measures of how effectively an object dissipates heat. Typically, the larger the device, the more surface area available for power dissipation so that the object's thermal resistance will be lower.

### Ordering Information

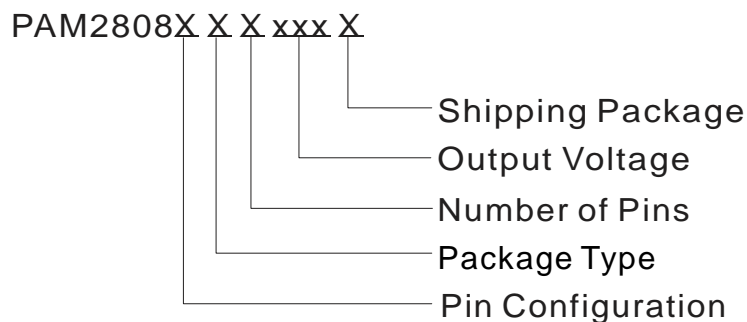

Pin Configuration	Package Type	Number of Pins	Shipping Package
B Type: 1. NC 2. VIN 3. EN 4. GND 5. NC 6. FB 7. VOUT 8. NC	L: SOP-8(EP)	B: 8	R: Tape & Reel

Part Number	Marking	Package Type	MOQ & Shipping Pckage
PAM2808BLBR	P2808 XXXYW	SOP-8(EP)	2,500 Units/Tapes & Reel

### Outline Dimensions

#### SOP-8(EP)

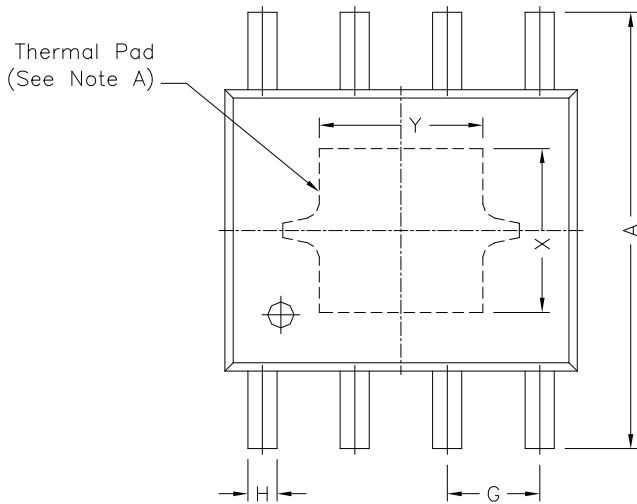

REF.	DIMENSIONS	
	Millimeters	
	Min.	Max.
A	5.80	6.20
B	4.80	5.00
C	3.80	4.00
D	0°	8°
E	0.40	0.90
F	0.19	0.25
M	0	0.15
H	0.35	0.49
L	1.35	1.75
G	1.27 TYP.	
Option1	X	2.28
	Y	2.28
Option2	X	2.41
	Y	3.30

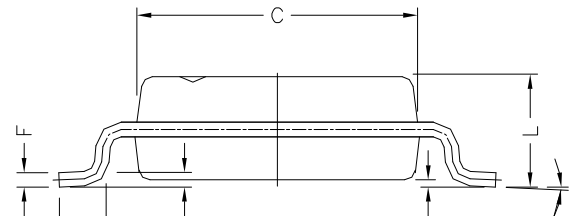
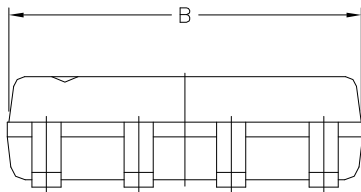





## Стандарт Электрон Связь

Мы молодая и активно развивающаяся компания в области поставок электронных компонентов. Мы поставляем электронные компоненты отечественного и импортного производства напрямую от производителей и с крупнейших складов мира.

Благодаря сотрудничеству с мировыми поставщиками мы осуществляем комплексные и плановые поставки широчайшего спектра электронных компонентов.

Собственная эффективная логистика и склад в обеспечивает надежную поставку продукции в точно указанные сроки по всей России.

Мы осуществляем техническую поддержку нашим клиентам и предпродажную проверку качества продукции. На все поставляемые продукты мы предоставляем гарантию .

Осуществляем поставки продукции под контролем ВП МО РФ на предприятия военно-промышленного комплекса России , а также работаем в рамках 275 ФЗ с открытием отдельных счетов в уполномоченном банке. Система менеджмента качества компании соответствует требованиям ГОСТ ISO 9001.

Минимальные сроки поставки, гибкие цены, неограниченный ассортимент и индивидуальный подход к клиентам являются основой для выстраивания долгосрочного и эффективного сотрудничества с предприятиями радиоэлектронной промышленности, предприятиями ВПК и научно-исследовательскими институтами России.

С нами вы становитесь еще успешнее!

### Наши контакты:

**Телефон:** +7 812 627 14 35

**Электронная почта:** [sales@st-electron.ru](mailto:sales@st-electron.ru)

**Адрес:** 198099, Санкт-Петербург,  
Промышленная ул, дом № 19, литера Н,  
помещение 100-Н Офис 331