



# **RabbitCore RCM3365/RCM3375**

C-Programmable Core Module  
with NAND Flash Mass Storage and Ethernet

## **User's Manual**

019-0150 • 080528-G

# RabbitCore RCM3365/RCM3375 User's Manual

Part Number 019-0150 • 080528-G • Printed in U.S.A.

©2005–2008 Digi International Inc. • All rights reserved.

No part of the contents of this manual may be reproduced or transmitted in any form or by any means without the express written permission of Digi International.

Permission is granted to make one or more copies as long as the copyright page contained therein is included. These copies of the manuals may not be let or sold for any reason without the express written permission of Digi International.

Digi International reserves the right to make changes and improvements to its products without providing notice.

## Trademarks

Rabbit, RabbitCore, and Dynamic C are registered trademarks of Digi International Inc.

Rabbit 3000 is a trademark of Digi International Inc.

xD-Picture Card is a trademark of Fuji Photo Film Co., Olympus Corporation, and Toshiba Corporation.

The latest revision of this manual is available on the Rabbit Web site, [www.rabbit.com](http://www.rabbit.com), for free, unregistered download.

**Rabbit Semiconductor Inc.**

[www.rabbit.com](http://www.rabbit.com)

# TABLE OF CONTENTS

<b>Chapter 1. Introduction</b>	<b>1</b>
1.1 RCM3365 and RCM3375 Features .....	2
1.2 Comparing the RCM3900/RCM3910 and RCM3365/RCM3375 .....	4
1.3 Advantages of the RCM3365 and RCM3375 .....	5
1.4 Development and Evaluation Tools .....	6
1.4.1 RCM3365/RCM3375 Development Kit .....	6
1.4.2 Software .....	7
1.4.3 Accessories .....	7
1.4.4 Online Documentation .....	7
<b>Chapter 2. Getting Started</b>	<b>9</b>
2.1 Install Dynamic C .....	9
2.2 Hardware Connections .....	10
2.2.1 Step 1 — Attach Module to Prototyping Board .....	10
2.2.2 Step 2 — Connect Serial Programming Cable .....	11
2.2.2.1 Programming via Ethernet Option .....	12
2.2.3 Step 3 — Connect Power .....	13
2.2.3.1 Alternate Power-Supply Connections .....	13
2.3 Starting Dynamic C .....	14
2.3.1 Running Dynamic C via Serial Programming Cable .....	15
2.3.1.1 Run a Sample Program .....	15
2.3.1.2 Troubleshooting .....	15
2.3.2 Running Dynamic C via Ethernet Cables .....	16
2.3.2.1 Run a Sample Program .....	16
2.3.2.2 Troubleshooting .....	17
2.4 Where Do I Go From Here? .....	17
2.4.1 Technical Support .....	17
<b>Chapter 3. Running Sample Programs</b>	<b>19</b>
3.1 Introduction .....	19
3.2 Sample Programs .....	20
3.2.1 Use of NAND Flash .....	21
3.2.2 Hot-Swapping xD-Picture Card .....	23
3.2.3 Serial Communication .....	24
3.2.4 Real-Time Clock .....	25
3.2.5 RabbitNet .....	26
3.2.6 Other Sample Programs .....	26
<b>Chapter 4. Hardware Reference</b>	<b>27</b>
4.1 RCM3365/RCM3375 Inputs and Outputs .....	28
4.1.1 Memory I/O Interface .....	33
4.1.2 Other Inputs and Outputs .....	33
4.1.3 LEDs .....	33
4.2 Serial Communication .....	34
4.2.1 Serial Ports .....	34
4.2.2 Ethernet Port .....	34
4.2.3 Serial Programming Port .....	35

4.3	Serial Programming Cable .....	36
4.3.1	Changing Between Program Mode and Run Mode.....	36
4.3.2	Standalone Operation of the RCM3365/RCM3375 .....	37
4.4	Memory .....	38
4.4.1	SRAM.....	38
4.4.2	Flash EPROM.....	38
4.4.3	NAND Flash.....	38
4.5	Other Hardware .....	40
4.5.1	Clock Doubler .....	40
4.5.2	Spectrum Spreader.....	40
<b>Chapter 5. Software Reference</b>		<b>41</b>
5.1	More About Dynamic C.....	41
5.1.1	Developing Programs Remotely with Dynamic C .....	43
5.2	Dynamic C Functions.....	44
5.2.1	Digital I/O.....	44
5.2.2	SRAM Use.....	44
5.2.3	Serial Communication Drivers .....	45
5.2.4	TCP/IP Drivers .....	45
5.2.5	NAND Flash Drivers.....	45
5.2.6	Prototyping Board Functions.....	46
5.2.6.1	Board Initialization .....	46
5.2.6.2	Digital I/O.....	47
5.2.6.3	Switches, LEDs, and Relay .....	48
5.2.6.4	Serial Communication .....	49
5.2.6.5	RabbitNet Port .....	50
5.3	Upgrading Dynamic C .....	52
5.3.1	Extras.....	52
<b>Chapter 6. Using the TCP/IP Features</b>		<b>53</b>
6.1	TCP/IP Connections .....	53
6.2	TCP/IP Primer on IP Addresses .....	55
6.2.1	IP Addresses Explained.....	57
6.2.2	How IP Addresses are Used .....	58
6.2.3	Dynamically Assigned Internet Addresses.....	59
6.3	Placing Your Device on the Network .....	60
6.4	Running TCP/IP Sample Programs.....	61
6.4.1	How to Set IP Addresses in the Sample Programs.....	62
6.4.2	How to Set Up your Computer for Direct Connect.....	63
6.5	Run the PINGME.C Sample Program.....	64
6.6	Running Additional Sample Programs With Direct Connect .....	64
6.6.1	RabbitWeb Sample Programs.....	65
6.7	Where Do I Go From Here?.....	65
<b>Appendix A. RCM3365/RCM3375 Specifications</b>		<b>67</b>
A.1	Electrical and Mechanical Characteristics .....	68
A.1.1	Headers .....	72
A.2	Bus Loading .....	73
A.3	Rabbit 3000 DC Characteristics .....	76
A.4	I/O Buffer Sourcing and Sinking Limit.....	77
A.5	Jumper Configurations .....	78
A.6	Conformal Coating .....	80
<b>Appendix B. Prototyping Board</b>		<b>81</b>
B.1	Introduction .....	82
B.1.1	Prototyping Board Features .....	83
B.2	Mechanical Dimensions and Layout .....	85

B.3 Power Supply .....	87
B.4 Using the Prototyping Board.....	88
B.4.1 Adding Other Components.....	89
B.4.2 Digital I/O.....	90
B.4.2.1 Digital Inputs .....	90
B.4.3 CMOS Digital Outputs.....	91
B.4.4 Sinking Digital Outputs.....	91
B.4.5 Relay Outputs .....	91
B.4.6 Serial Communication.....	92
B.4.6.1 RS-232 .....	93
B.4.6.2 RS-485 .....	94
B.4.7 RabbitNet Ports .....	95
B.4.8 Other Prototyping Board Modules .....	96
B.4.9 Quadrature Decoder .....	96
B.4.10 Stepper-Motor Control .....	96
B.5 Prototyping Board Jumper Configurations .....	98
B.6 Use of Rabbit 3000 Parallel Ports .....	100
<b>Appendix C. LCD/Keypad Module</b> .....	<b>103</b>
C.1 Specifications .....	103
C.2 Contrast Adjustments for All Boards.....	105
C.3 Keypad Labeling .....	106
C.4 Header Pinouts .....	107
C.4.1 I/O Address Assignments.....	107
C.5 Mounting LCD/Keypad Module on the Prototyping Board .....	108
C.6 Bezel-Mount Installation.....	109
C.6.1 Connect the LCD/Keypad Module to Your Prototyping Board.....	111
C.7 Sample Programs .....	112
C.8 LCD/Keypad Module Function Calls .....	113
C.8.1 LCD/Keypad Module Initialization.....	113
C.8.2 LEDs.....	113
C.8.3 LCD Display.....	114
C.8.4 Keypad.....	130
<b>Appendix D. Power Supply</b> .....	<b>133</b>
D.1 Power Supplies.....	133
D.1.1 Battery Backup.....	133
D.1.2 Battery-Backup Circuit .....	134
D.1.3 Reset Generator .....	135
<b>Appendix E. Programming via Ethernet Crossover Cable</b> .....	<b>137</b>
E.1 Load TCP/IP Parameters to the RCM3365 Module.....	138
E.2 Load TCP/IP Parameters to the PC, Notebook, or Workstation .....	139
E.3 Run a Program.....	141
E.3.1 Troubleshooting.....	141
<b>Appendix F. RabbitNet</b> .....	<b>143</b>
F.1 General RabbitNet Description .....	143
F.1.1 RabbitNet Connections .....	143
F.1.2 RabbitNet Peripheral Cards .....	144
F.2 Physical Implementation .....	145
F.2.1 Control and Routing.....	145
F.3 Function Calls.....	146
F.3.1 Status Byte .....	152
<b>Index</b> .....	<b>153</b>





# 1. INTRODUCTION

The RCM3365 and RCM3375 RabbitCore modules feature a compact module that incorporates the latest revision of the powerful Rabbit<sup>®</sup> 3000 microprocessor, flash memory, mass storage (NAND flash), static RAM, and digital I/O ports. The RCM3365 and RCM3375 present a new form of embedded flexibility with removable (“hot-swappable”) memory cards. The RCM3365 and RCM3375 both have an integrated 10/100Base-T Ethernet port, and provide for LAN and Internet-enabled systems to be built as easily as serial-communication systems.

In addition to the features already mentioned above, the RCM3365 and RCM3375 have two clocks (main oscillator and real-time clock), reset circuitry, and the circuitry necessary for management of battery backup of the Rabbit 3000’s internal real-time clock and the static RAM. Two 34-pin headers bring out the Rabbit 3000 I/O bus lines, parallel ports, and serial ports.

The RCM3365/RCM3375’s mass-storage capabilities make them suited to running the optional Dynamic C FAT file system module where data are stored and handled using the same directory file structure commonly used on PCs. A removable *xD-Picture Card* can be hot-swapped to transfer data quickly and easily using a standardized file system that can be read away from the RCM3365/RCM3375 installation.

The RCM3365 or RCM3375 receives +3.3 V power from the customer-supplied motherboard on which it is mounted. The RCM3365 and RCM3375 can interface with all kinds of CMOS-compatible digital devices through the motherboard.

The Development Kit has what you need to design your own microprocessor-based system: a complete Dynamic C software development system including the Dynamic C FAT File System module, and a Prototyping Board that allows you to evaluate the RCM3365 or RCM3375, and to prototype circuits that interface to the RCM3365 or RCM3375 module.

## 1.1 RCM3365 and RCM3375 Features

- Small size: 1.85" x 2.73" x 0.86"  
(47 mm x 69 mm x 22 mm)
- Microprocessor: Rabbit 3000 running at 44.2 MHz
- 52 parallel 5 V tolerant I/O lines: 44 configurable for I/O, 4 fixed inputs, 4 fixed outputs
- Three additional digital inputs, two additional digital outputs
- External reset
- Alternate I/O bus can be configured for 8 data lines and 6 address lines (shared with parallel I/O lines), plus I/O read/write
- Ten 8-bit timers (six cascadable) and one 10-bit timer with two match registers
- 512K flash memory, 512K program execution SRAM, 512K data SRAM
- Fixed and hot-swappable mass-storage flash-memory options, which may be used with the standardized directory structure supported by the Dynamic C FAT File System module.
- Real-time clock
- Watchdog supervisor
- Provision for customer-supplied backup battery via connections on header J4
- 10-bit free-running PWM counter and four pulse-width registers
- Two-channel Input Capture (shared with parallel I/O ports) can be used to time input signals from various port pins
- Two-channel Quadrature Decoder accepts inputs from external incremental encoder modules
- Five or six 3.3 V CMOS-compatible serial ports with a maximum asynchronous baud rate of 5.525 Mbps. Three ports are configurable as a clocked serial port (SPI), and two ports are configurable as SDLC/HDLC serial ports (shared with parallel I/O ports).
- Supports 1.15 Mbps IrDA transceiver
- Supports Dynamic C RabbitSys, which supports Ethernet access for remote application updates, and remote monitoring and control of a RabbitSys-enabled RCM3365

The RCM3900/RCM3910 and RCM3365/RCM3375 RabbitCore modules are similar to the RCM3305/RCM3315 and RCM3309/RCM3319, but they use fixed NAND or removable media for their mass-storage memories instead of the fixed serial flash options of the RCM3305/RCM3315 and the RCM3309/RCM3319.



Table 1 below summarizes the main features of the RCM3365 and the RCM3375 modules.

**Table 1. RCM3365/RCM3375 Features**

Feature	RCM3365	RCM3375
Microprocessor	Rabbit 3000 running at 44.2 MHz	
SRAM	512K program (fast SRAM) + 512K data	
Flash Memory (program)	512K	
Flash Memory (mass data storage)	32MB (fixed)* + up to 128MB (removable) (NAND flash)	up to 128MB (removable) (NAND flash)
Serial Ports	6 shared high-speed, 3.3 V CMOS-compatible ports: <ul style="list-style-type: none"> <li>• all 6 are configurable as asynchronous serial ports;</li> <li>• 4 are configurable as a clocked serial port (SPI) and 1 is configurable as an HDLC serial port;</li> <li>• option for second HDLC serial port at the expense of 2 clocked serial ports (SPI)</li> </ul>	

\* RCM3365 modules sold before 2008 had 16MB fixed NAND flash memory.

**NOTE:** M-type *xD-Picture Cards* are *not* supported at this time.

The RCM3365 and RCM3375 are programmed over a standard PC serial port through a serial programming cable supplied with the Development Kit, and can also be programmed through a USB port with an RS-232/USB converter, or directly over an Ethernet link using the Dynamic C download manager with or without a RabbitLink; Dynamic C RabbitSys may also be used with a RabbitSys-enabled RCM3365 over an Ethernet link.

Appendix A provides detailed specifications for the RCM3365 and the RCM3375.

## 1.2 Comparing the RCM3900/RCM3910 and RCM3365/RCM3375

We can no longer obtain certain components for the RCM3365/RCM3375 RabbitCore modules that support the originally specified  $-40^{\circ}\text{C}$  to  $+70^{\circ}\text{C}$  temperature range. Instead of changing the design of the RCM3365/RCM3375 RabbitCore modules to handle available components specified for the original temperature range, we decided to develop a new product line — the RCM3900 series.

The RCM3900 series of RabbitCore modules is similar in form, dimensions, and function to the RCM3365/RCM3375 modules. We strongly recommend that existing RCM3365/3375 customers and designers of new systems consider using the new RCM3900 series RabbitCore modules.

This section compares the two lines of RabbitCore modules.

- **Temperature Specifications** — RCM3365/RCM3375 RabbitCore modules manufactured after May, 2008, are specified to operate at  $0^{\circ}\text{C}$  to  $+70^{\circ}\text{C}$ . The RCM3900/RCM3910, rated for  $-20^{\circ}\text{C}$  to  $+85^{\circ}\text{C}$ , are offered to customers requiring a larger temperature range after May, 2008.
- **Removable Mass Storage** — The hot-swappable *xD-Picture Card*<sup>™</sup> mass storage device with up to 128MB of memory has been replaced with the *miniSD Card* with up to 1GB of memory. The *miniSD Card* is more readily available today, and is expected to remain readily available for a long time. In addition, *miniSD Cards* provide a significantly larger memory capacity, which has been requested by customers. The trade-off for the larger memory capacity is that the data transfer rate to/from the *miniSD Card* is about an order of magnitude slower than to/from the *xD-Picture Card*.

**NOTE:** RCM3365/RCM3375 RabbitCore modules may eventually be discontinued because of changes to the *xD-Picture Card*<sup>™</sup>.

- **Serial Ports** — Serial Port B, available as either a clocked serial port or an asynchronous serial port on the RCM3365/RCM3375, is used by the RCM3900/RCM3910 as a clocked serial peripheral interface (SPI) for the *miniSD*<sup>™</sup> *Card*, and is not brought out for customer use.
- **General-Purpose I/O** — PD2, a configurable I/O pin on the RCM3365/RCM3375, is used to enable/disable the RabbitNet SPI interface when the RCM3365/RCM3375 is installed on the Prototyping Board. The RCM3900/RCM3910 use PD2 to detect whether the *miniSD*<sup>™</sup> *Card* is installed, and so PD2 is not brought out for customer use on the RCM3900/RCM3910.
- **Maximum Current** — The RCM3365/RCM3375 draws 250 mA vs. the 325 mA required by the RCM3900/RCM3910.
- **LEDs** — The **SPEED** and user (**USR/BSY**)LED locations have been swapped between the RCM3365/RCM3375 and the RCM3900/RCM3910, the **LNK/ACT** LEDs have been combined to one LED on the RCM3900/RCM3910, and the RCM3900/RCM3910 has an **FDX/COL** LED instead of the **FM** LED on the RCM3365/RCM3375. The LED placements on the boards remain unchanged.

- **Ethernet chip** — A different Ethernet controller chip is used on the RCM3900/RCM3910. The Ethernet chip is able to detect automatically whether a crossover cable or a straight-through cable is being used in a particular setup, and will configure the signals on the Ethernet jack interface.
- **Dynamic C** — As long as no low-level FAT file system calls or direct *xD-Picture Card* access calls to the **NFLASH.LIB** library were used in your application developed for the RCM3365/RCM3375, you may run that application on the RCM3900/RCM3910 after you recompile it using Dynamic C v. 9.60.

**NOTE:** The Dynamic C RabbitSys option for programming an RCM3365 over an Ethernet link is not supported for the RCM3900.

### 1.3 Advantages of the RCM3365 and RCM3375

- Fast time to market using a fully engineered, “ready-to-run/ready-to-program” micro-processor core.
- Competitive pricing when compared with the alternative of purchasing and assembling individual components.
- Easy C-language program development and debugging
- Program download utility (Rabbit Field Utility) and cloning board options for rapid production loading of programs.
- Generous memory size allows large programs with tens of thousands of lines of code, and substantial data storage.
- Integrated Ethernet port for network connectivity, with royalty-free TCP/IP software.
- Ideal for network-enabling security and access systems, home automation, HVAC systems, and industrial controls

## 1.4 Development and Evaluation Tools

### 1.4.1 RCM3365/RCM3375 Development Kit

The RCM3365/RCM3375 Development Kit contains the hardware you need to use your RCM3365 or RCM3375 module.

- RCM3365 module.
- Prototyping Board.
- AC adapter, 12 V DC, 1 A (included only with Development Kits sold for the North American market). A header plug leading to bare leads is provided to allow overseas users to connect their own power supply with a DC output of 8–30 V.)
- Serial programming cable with 10-pin header and DE9 connections.
- 2 CDs — *Dynamic C*<sup>®</sup> and *Dynamic C FAT File System* module — with complete product documentation on disk.
- *Getting Started* instructions.
- 32 MB *xD-Picture Card*<sup>™</sup>.
- Accessory parts for use on the Prototyping Board.
- Screwdriver and Ethernet cables.
- *Rabbit 3000 Processor Easy Reference* poster.
- Registration card.

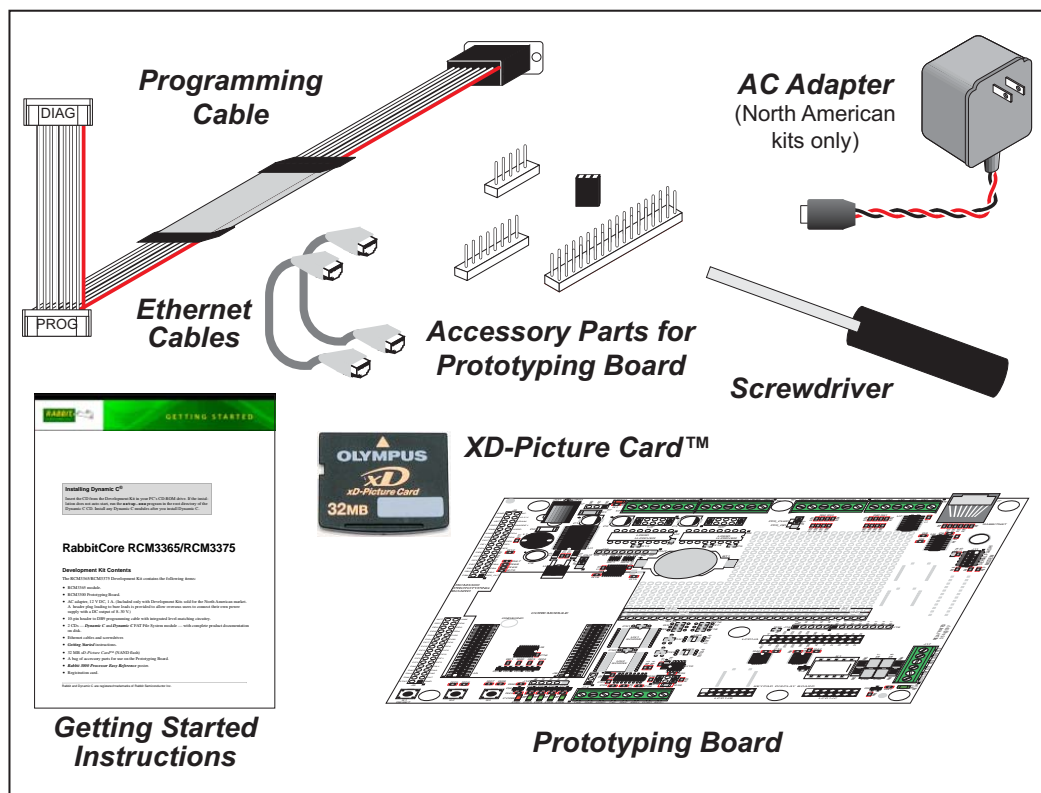

Figure 1. RCM3365/RCM3375 Development Kit

## 1.4.2 Software

The RCM3365 and the RCM3375 are programmed using version 9.24 or later of Dynamic C. A compatible version is included on the Development Kit CD-ROM.

Rabbit is also offering RCM3365 RabbitCore modules preloaded with Dynamic C RabbitSys firmware to allow these modules to run Dynamic C RabbitSys. Dynamic C RabbitSys requires Dynamic C version 9.30 or later, and allows the RCM3365 to be accessed via an Ethernet connection for remote application updates, and for remote monitoring and control. A RabbitSys Development Kit is available with all the hardware and software tools that are needed to develop a RabbitSys application.

Dynamic C v. 9.60 includes the popular  $\mu$ C/OS-II real-time operating system, point-to-point protocol (PPP), FAT file system, RabbitWeb, and other select libraries that were previously sold as individual Dynamic C modules.

Rabbit also offers for purchase the Rabbit Embedded Security Pack featuring the Secure Sockets Layer (SSL) and a specific Advanced Encryption Standard (AES) library. In addition to the Web-based technical support included at no extra charge, a one-year telephone-based technical support subscription is also available for purchase. Visit our Web site at [www.rabbit.com](http://www.rabbit.com) for further information and complete documentation, or contact your Rabbit sales representative or authorized distributor.

**NOTE:** Version 2.10 or later of the Dynamic C FAT file system module is required to use the FAT file system with the RCM3365 and RCM3375 models.

## 1.4.3 Accessories

Rabbit has available a USB Removable Memory Card Reader and a Connector Adapter Board.

- USB Removable Memory Card Reader (Part No. 20-101-1104)—allows you to read data from the *xD-Picture Card* via your PC.
- Connector Adapter Board (Part No. 151-0114)—allows you to plug the RCM3365/RCM3375 whose headers have a 2 mm pitch into header sockets with a 0.1" pitch.

Visit our Web site at [www.rabbit.com](http://www.rabbit.com) or contact your Rabbit sales representative or authorized distributor for further information.

## 1.4.4 Online Documentation

The online documentation is installed along with Dynamic C, and an icon for the documentation menu is placed on the workstation's desktop. Double-click this icon to reach the menu. If the icon is missing, use your browser to find and load **default.htm** in the **docs** folder, found in the Dynamic C installation folder.

The latest versions of all documents are always available for free, unregistered download from our Web sites as well.



## 2. GETTING STARTED

This chapter explains how to set up and use the RCM3365/RCM3375 modules with the accompanying Prototyping Board.

**NOTE:** It is assumed that you have a Development Kit. If you purchased an RCM3365 or RCM3375 module by itself, you will have to adapt the information in this chapter and elsewhere to your test and development setup.

### 2.1 Install Dynamic C

To develop and debug programs for the RCM3365/RCM3375 (and for all other Rabbit hardware), you must install and use Dynamic C.

If you have not yet installed Dynamic C version 9.24 (or a later version), do so now by inserting the Dynamic C CD from the Development Kit in your PC's CD-ROM drive. If autorun is enabled, the CD installation will begin automatically.

If autorun is disabled or the installation otherwise does not start, use the Windows **Start | Run** menu or Windows Disk Explorer to launch **setup.exe** from the root folder of the CD-ROM.

The installation program will guide you through the installation process. Most steps of the process are self-explanatory.

Dynamic C uses a COM (serial) port to communicate with the target development system. The installation allows you to choose the COM port that will be used. The default selection is COM1. You may select any available port for Dynamic C's use. If you are not certain which port is available, select COM1. This selection can be changed later within Dynamic C.

**NOTE:** The installation utility does not check the selected COM port in any way. Specifying a port in use by another device (mouse, modem, etc.) may lead to a message such as **"could not open serial port"** when Dynamic C is started.

Once your installation is complete, you will have up to three icons on your PC desktop. One icon is for Dynamic C, one opens the documentation menu, and the third is for the Rabbit Field Utility, a tool used to download precompiled software to a target system.

If you have purchased the optional Dynamic C Rabbit Embedded Security Pack, install it after installing Dynamic C. You must install the Rabbit Embedded Security Pack in the same directory where Dynamic C was installed.

## 2.2 Hardware Connections

There are three steps to connecting the Prototyping Board for use with Dynamic C and the sample programs:

1. Attach the RCM3365/RCM3375 module to the Prototyping Board.
2. Connect the serial programming cable between the RCM3365/RCM3375 and the workstation PC or if you have an RCM3365 with RabbitSys firmware you may connect the RCM3365 and the PC using Ethernet cables.
3. Connect the power supply to the Prototyping Board.

### 2.2.1 Step 1 — Attach Module to Prototyping Board

Turn the RCM3365/RCM3375 module so that the Ethernet jack is facing the direction shown in Figure 2 below. Align the pins from headers J3 and J4 on the bottom side of the module into header sockets JA and JB on the Prototyping Board. The picture card (NAND flash) does not have to be inserted into connector J6 on the RCM3365/RCM3375 at this time.

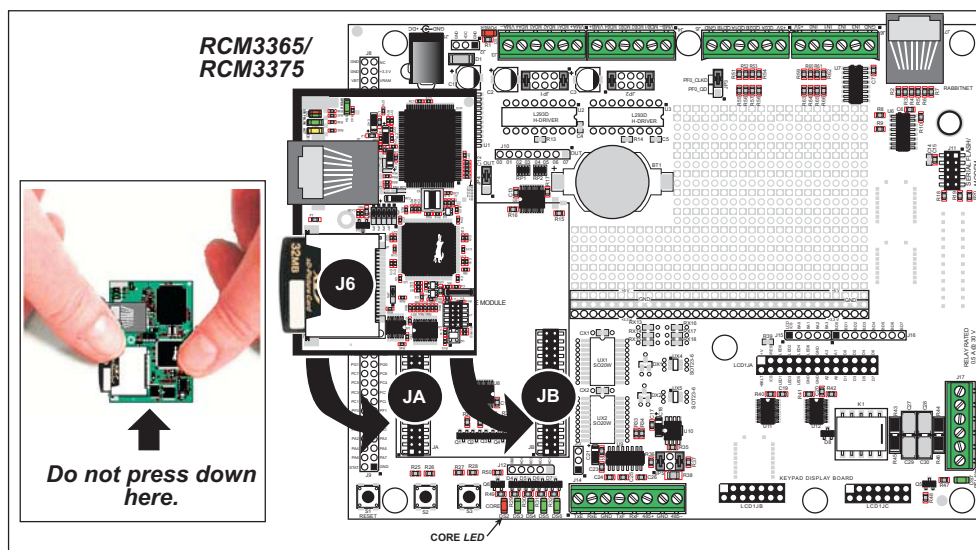

**Figure 2. Install the RCM3365/RCM3375 Module on the Prototyping Board**

**NOTE:** It is important that you line up the pins on headers J3 and J4 of the RCM3365/RCM3375 module exactly with the corresponding pins of header sockets JA and JB on the Prototyping Board. The header pins may become bent or damaged if the pin alignment is offset, and the module will not work. Permanent electrical damage to the module may also result if a misaligned module is powered up.

Press the module's pins firmly into the Prototyping Board header sockets—press down in the area above the header pins using your thumbs or fingers over the header pins as shown in Figure 2. Do not press down on the picture card connector (J6) unless the picture card is installed, but rather press down on the circuit board along the edge by the connector. Also, do not press down on the middle of the module to avoid flexing the module, which could damage the module or components on the module.

Should you need to remove the module, grasp it with your fingers along the sides by the connectors and gently work the module up to pull the pins away from the sockets where they are installed. Do not remove the module by grasping it at the top and bottom.



## 2.2.2 Step 2 — Connect Serial Programming Cable

The serial programming cable connects the RCM3365/RCM3375 to the PC running Dynamic C to download programs and to monitor the module during debugging.

Connect the 10-pin connector of the serial programming cable labeled **PROG** to header J1 on the RCM3365/RCM3375 module as shown in Figure 3. There is a small dot on the circuit board next to pin 1 of header J1. Be sure to orient the marked (usually red) edge of the cable towards pin 1 of the connector. (Do not use the **DIAG** connector, which is used for a nonprogramming serial connection.)

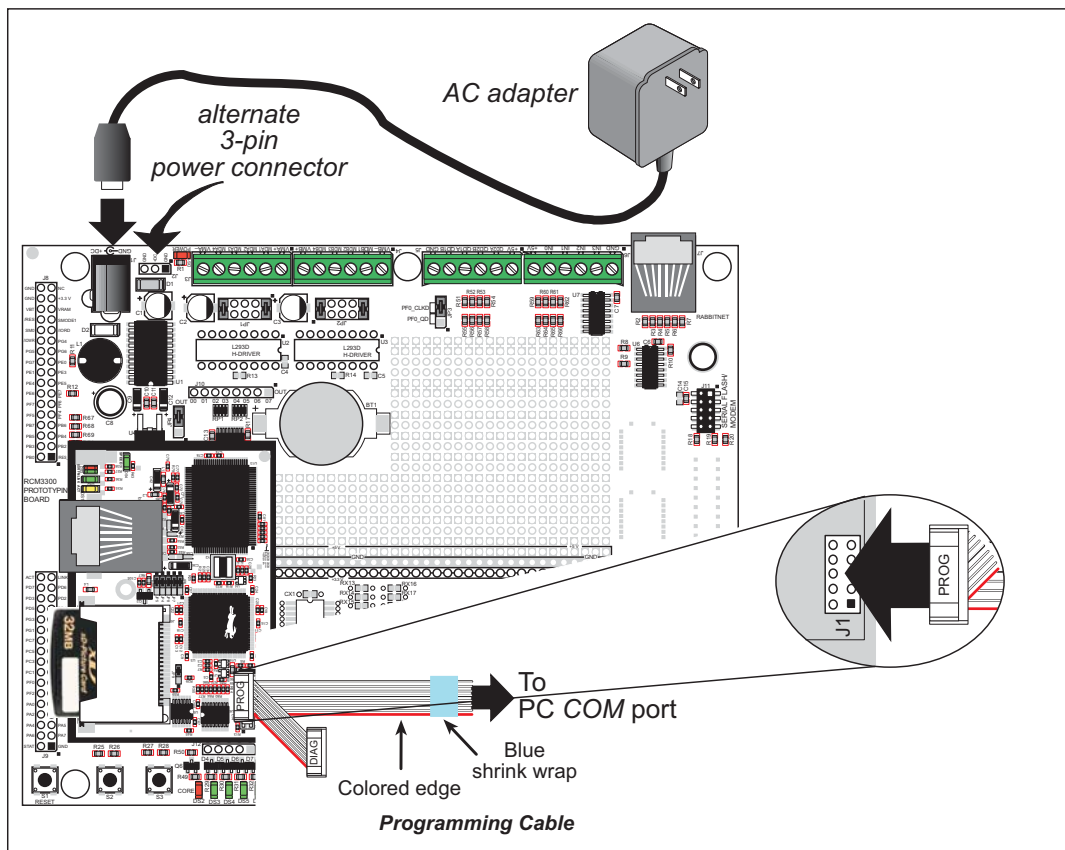

**Figure 3. Connect Serial Programming Cable and Power Supply**

**NOTE:** Be sure to use the serial programming cable (part number 101-0542) supplied with this Development Kit—the serial programming cable has blue shrink wrap around the RS-232 converter section located in the middle of the cable. Programming cables with clear or red shrink wrap from other Rabbit kits are not designed to work with RCM3365/RCM3375 modules.

Connect the other end of the serial programming cable to a COM port on your PC.

**NOTE:** Some PCs now come equipped only with a USB port. It may be possible to use an RS-232/USB converter (Part No. 20-151--0178) with the serial programming cable supplied with the RCM3365/RCM3375 Development Kit. Note that not all RS-232/USB converters work with Dynamic C.

### 2.2.2.1 Programming via Ethernet Option

An Ethernet cable connects a RabbitSys-enabled RCM3365 to the PC running Dynamic C with Dynamic C RabbitSys via a DHCP network to download programs and to monitor the RCM3365 module during debugging.

Use a straight-through CAT 5/6 Ethernet cable to connect the Ethernet jack on the RCM3365 to a DHCP-enabled network. Your PC should also be connected to this network—you will need a second straight-through CAT 5/6 Ethernet cable to connect the PC to the network since only one straight-through Ethernet cable is supplied with the Development Kit.

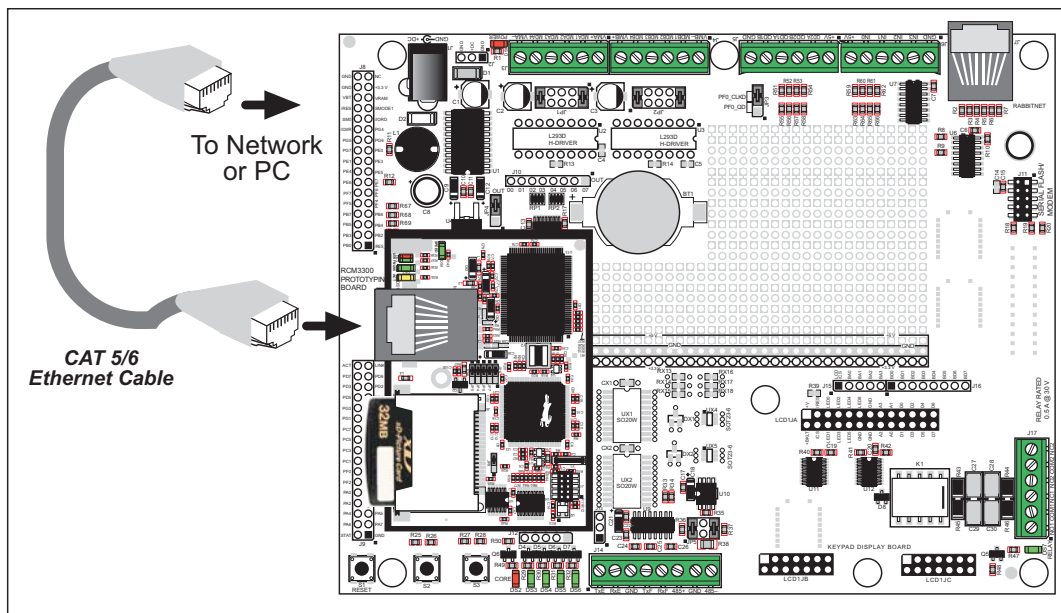

**Figure 4. Connect Ethernet Cable for Ethernet Programming Option**

You may also use a crossover CAT 5/6 Ethernet cable to connect the Ethernet jack on the RCM3365 directly to your PC, but there will be additional steps required to configure the TCP/IP parameters on the RCM3365 and on your PC if your PC does not have a DHCP server. These steps are described in Appendix E.

### 2.2.3 Step 3 — Connect Power

When all other connections have been made, you can connect power to the Prototyping Board. Connect the wall transformer to jack J1 on the Prototyping Board as shown in Figure 3.

Plug in the wall transformer. The core LED on the Prototyping Board should light up. The RCM3365/RCM3375 and the Prototyping Board are now ready to be used.

**NOTE:** A **RESET** button is provided on the Prototyping Board to allow a hardware reset without disconnecting power. The RCM3365/RCM3375 can also be reset from Dynamic C by pressing **<Ctrl-Y>** if your PC is connected to the RCM3365/RCM3375 via the serial programming cable.

#### 2.2.3.1 Alternate Power-Supply Connections

All Development Kits include a header connector that may be used to connect your power supply to 3-pin header J2 on the Prototyping Board. The connector may be attached either way as long as it is not offset to one side—the center pin of J2 is always connected to the positive terminal, and either edge pin is negative. The power supply should deliver 8 V to 30 V DC at 8 W.

## 2.3 Starting Dynamic C

Once the RCM3365/RCM3375 is connected as described in the preceding pages, start Dynamic C by double-clicking on the Dynamic C icon on your desktop or in your **Start** menu. Select **Code and BIOS in Flash, Run in RAM** on the “Compiler” tab in the Dynamic C **Options > Project Options** menu. Click **OK**.

Section 2.3.1 explains the remaining Dynamic C configurations to run a sample program via the serial programming cable, and Section 2.3.2 explains the remaining Dynamic C configurations to run a sample program via an Ethernet cable.

## 2.3.1 Running Dynamic C via Serial Programming Cable

Dynamic C uses the serial port on your PC that you specified during installation.

If you are using a USB port to connect your computer to the RCM3365/RCM3375 module, choose **Options > Project Options** and select “Use USB to Serial Converter” on the **Communications** tab.

### 2.3.1.1 Run a Sample Program

Use the **File** menu to open the sample program **PONG.C**, which is in the Dynamic C **SAMPLES** folder. Press function key **F9** to compile and run the program. The **STUDIO** window will open on your PC and will display a small square bouncing around in a box.

This program shows that the CPU is working. The sample program described in Section 6.5, “Run the PINGME.C Sample Program,” tests the TCP/IP portion of the board.

### 2.3.1.2 Troubleshooting

If Dynamic C cannot find the target system (error message **"No Rabbit Processor Detected."**):

- Check that the RCM3365/RCM3375 is powered correctly — the red **CORE** LED on the Prototyping Board should be lit when the RCM3365/RCM3375 is mounted on the Prototyping Board and the AC adapter is plugged in.
- Check both ends of the programming cable to ensure that they are firmly plugged into the PC and the **PROG** connector, not the **DIAG** connector, is plugged in to the programming port on the RCM3365/RCM3375 with the marked (colored) edge of the programming cable towards pin 1 of the programming header.
- Ensure that the RCM3365/RCM3375 module is firmly and correctly installed in its connectors on the Prototyping Board.
- Dynamic C uses the COM port specified during installation. Select a different COM port within Dynamic C. From the **Options** menu, select **Project Options**, then select **Communications**. Select another COM port from the list, then click OK. Press **<Ctrl-Y>** to force Dynamic C to recompile the BIOS. If Dynamic C still reports it is unable to locate the target system, repeat the above steps until you locate the COM port used by the programming cable.

If Dynamic C appears to compile the BIOS successfully, but you then receive a communication error message when you compile and load the sample program, it is possible that your PC cannot handle the higher program-loading baud rate. Try changing the maximum download rate to a slower baud rate as follows.

- Locate the **Serial Options** dialog in the Dynamic C **Options > Project Options > Communications** menu. Select a slower Max download baud rate.

If a program compiles and loads, but then loses target communication before you can begin debugging, it is possible that your PC cannot handle the default debugging baud rate. Try lowering the debugging baud rate as follows.

- Locate the **Serial Options** dialog in the Dynamic C **Options > Project Options > Communications** menu. Choose a lower debug baud rate.

## 2.3.2 Running Dynamic C via Ethernet Cables

The firmware needed to run RabbitSys has been preloaded on RCM3365 RabbitCore modules sold for use with Dynamic C RabbitSys. The software from the Dynamic C and the Dynamic C RabbitSys CDs must be installed on your PC. A system running RabbitSys can be connected to a DHCP network using straight-through Ethernet cables, or it can be connected directly to the PC via an Ethernet crossover cable.

- If you are connecting to a network with a DHCP server, use a CAT 5/6 straight-through Ethernet cable to connect the PC or workstation to the network, and connect the Ethernet jack on the RCM3365 to the network using a second CAT 5/6 straight-through Ethernet cable.
- If your PC or workstation is running a DHCP server, connect the CAT 5/6 Ethernet crossover cable from the PC or workstation directly to the Ethernet jack on the RCM3365. Follow the instructions below for a straight-through Ethernet cable.

**TIP:** It is recommended that you use one of the above options for a PC/workstation or network with a DHCP server or the serial cable programming option when you are using the RCM3365 for the first time since these options are easier to set up and run.

- If your PC/workstation does not have a DHCP server, you will have to enter the TCP/IP parameters into the RCM3365 module and on to the PC, notebook, or workstation. See Appendix E for more information on this option.

### Using DHCP Network with Straight-Through Ethernet Cables

Enable separate instruction and data spaces and select “Compile program in RabbitSys user mode” from the Dynamic C **Options > Project Options > Compiler** menu.

Before you compile and run a program via the Ethernet for the first time via a DHCP network, you must run the rdiscover utility by double-clicking it on your PC desktop. Your PC must be connected to the same DHCP network as the RCM3365. The utility will open a window and list the MAC addresses for any RabbitSys boards connected to the network.

Select a board from the list to display additional information such as the board’s Internet address. This is the IP address to enter when you access the Dynamic C **Options > Project Options > Communications** menu to select “Use TCP/IP Connection.” You must also enter “32023” for the Control Port and the default login values of “admin” and “password.”

#### 2.3.2.1 Run a Sample Program

Use the **File** menu to open the sample program **PONG.C**, which is in the Dynamic C **SAMPLES** folder. Press function key **F9** to compile and run the program. The **STUDIO** window will open on your PC and will display a small square bouncing around in a box.

This program shows that the CPU is working. The sample program described in Section 6.5, “Run the PINGME.C Sample Program,” tests the TCP/IP portion of the board.

### 2.3.2.2 Troubleshooting

If the rdiscover utility could not find your RCM3365:

- Check that your network has a DHCP server, and that the RCM3365 and your PC are connected to the same network.
- If you compiled and ran a sample program with the RabbitSys project option disabled, you may have overwritten the RabbitSys binary file. Use the serial programming cable to connect programming header J1 on the RCM3365 to your PC COM port to reload the RabbitSys binary file via the Dynamic C **Compile > Reload RabbitSys binary** menu.

If the rdiscover utility could not find your RCM3365, and you were unable to reload the RabbitSys binary file, your RCM3365 does not have the firmware to support Dynamic C RabbitSys and cannot be used with Dynamic C RabbitSys.

If Dynamic C returns an error message, check that the RCM3365 is powered correctly. The red **CORE** LED on the Prototyping Board should be lit when the RCM3365 is mounted on the Prototyping Board and the AC adapter is plugged in. Ensure that the RCM3365 module is firmly and correctly installed in its connectors on the Prototyping Board.

## 2.4 Where Do I Go From Here?

If the sample program ran fine, you are now ready to go on to other sample programs and to develop your own applications. The source code for the sample programs is provided to allow you to modify them for your own use. The *RCM3365/RCM3375 User's Manual* also provides complete hardware reference information and describes the software function calls for the RCM3365 and the RCM3375, the Prototyping Board, and the optional LCD/keypad module.

For advanced development topics, refer to the *Dynamic C User's Manual*, the *Dynamic C RabbitSys User's Manual*, and the *Dynamic C TCP/IP User's Manual*, also in the online documentation set.

### 2.4.1 Technical Support

**NOTE:** If you purchased your RCM3365/RCM3375 through a distributor or through a Rabbit partner, contact the distributor or partner first for technical support.

If there are any problems at this point:

- Use the Dynamic C **Help** menu to get further assistance with Dynamic C.
- Check the Rabbit Technical Bulletin Board and forums at [www.rabbit.com/support/bb/](http://www.rabbit.com/support/bb/) and at [www.rabbit.com/forums/](http://www.rabbit.com/forums/).
- Use the Technical Support e-mail form at [www.rabbit.com/support/](http://www.rabbit.com/support/).





## 3. RUNNING SAMPLE PROGRAMS

To develop and debug programs for the RCM3365/RCM3375 (and for all other Rabbit hardware), you must install and use Dynamic C.

### 3.1 Introduction

To help familiarize you with the RCM3365 and RCM3375 modules, Dynamic C includes several sample programs. Loading, executing and studying these programs will give you a solid hands-on overview of the RCM3365/RCM3375's capabilities, as well as a quick start using Dynamic C as an application development tool.

**NOTE:** The sample programs assume that you have at least an elementary grasp of the C programming language. If you do not, see the introductory pages of the *Dynamic C User's Manual* for a suggested reading list.

More complete information on Dynamic C is provided in the *Dynamic C User's Manual*.

In order to run the sample programs discussed in this chapter and elsewhere in this manual,

1. Your RCM3365/RCM3375 module must be plugged in to the Prototyping Board as described in Chapter 2, "Getting Started."
2. Dynamic C must be installed and running on your PC.
3. The RCM3365/RCM3375 module must be connected to your PC either through the serial programming cable or through an Ethernet cable/network if you have a RabbitSys-enabled RCM3365.
4. Power must be applied to the RCM3365/RCM3375 through the Prototyping Board.

Refer to Chapter 2, "Getting Started," if you need further information on these steps.

Since the RCM3365 and the RCM3375 run at 44.2 MHz and are equipped with a fast program execution SRAM, remember to allow the compiler to run the application in the fast program execution SRAM by selecting **Code and BIOS in Flash, Run in RAM** from the Dynamic C **Options > Project Options > Compiler** menu.

To run a sample program, open it with the **File** menu, then press function key **F9** to compile and run the program.

## 3.2 Sample Programs

Of the many sample programs included with Dynamic C, several are specific to the RCM3365 and the RCM3375. Sample programs illustrating the general operation of the RCM3365/RCM3375, serial communication, and the NAND flash are provided in the **SAMPLES\RCM3360** folder. Each sample program has comments that describe the purpose and function of the program. Follow the instructions at the beginning of the sample program. Note that the RCM3365/RCM3375 must be installed on the Prototyping Board when using the sample programs described in this chapter.

- **CONTROLLED.c**—Demonstrates use of the digital inputs by having you turn the LEDs on the Prototyping Board on or off from the **STDIO** window on your PC.

Once you compile and run **CONTROLLED.c**, the following display will appear in the Dynamic C **STDIO** window.

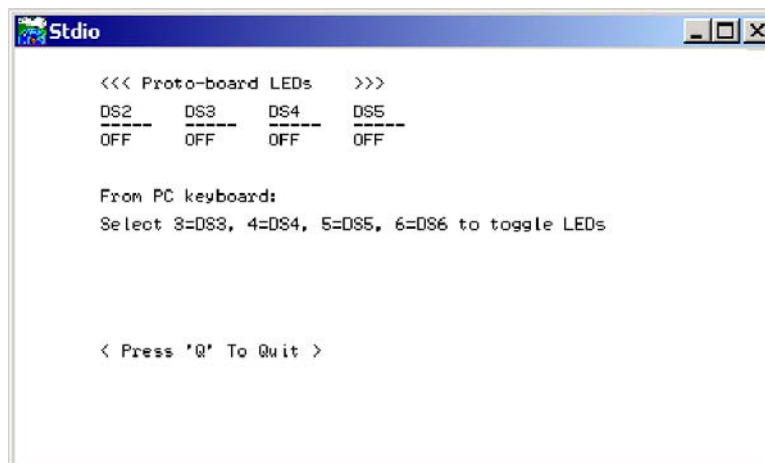

```
<<< Proto-board LEDs >>>
DS2   DS3   DS4   DS5
----   ---
OFF    OFF   OFF   OFF

From PC keyboard:
Select 3=DS3, 4=DS4, 5=DS5, 6=DS6 to toggle LEDs

< Press 'Q' To Quit >
```

Press “2” or “3” or “4” or “5” on your keyboard to select LED DS3 or DS4 or DS5 or DS6 on the Prototyping Board. Then follow the prompt in the Dynamic C **STDIO** window to turn the LED on or off.

- **FLASHLED.c**—Demonstrates assembly-language program by flashing the USR LED on the RCM3365/RCM3375 and LEDs DS3, DS4, DS5, and DS6 on the Prototyping Board.
- **SWRELAY.c**—Demonstrates the relay-switching function call using the relay installed on the Prototyping Board through screw-terminal header J17.
- **TOGGLESWITCH.c**—Uses costatements to detect switches S2 and S3 using debouncing. The corresponding LEDs (DS3 and DS4) will turn on or off.

Once you have loaded and executed these four programs and have an understanding of how Dynamic C and the RCM3365/RCM3375 modules interact, you can move on and try the other sample programs, or begin building your own.

### 3.2.1 Use of NAND Flash

The following sample programs can be found in the **SAMPLES\RCM3360\NANDFlash** folder. As you run most of these sample programs, you will be prompted in the Dynamic C **STDIO** window to select either the soldered-in NAND flash (RCM3365 model only) or the socketed *xD-Picture Card* (0 = soldered, 1 = socketed).

- **NFLASH\_DUMP.c**—This program is a utility for dumping the nonerased contents of a NAND flash chip to the Dynamic C **STDIO** window, and the contents may be redirected to a serial port.

When the sample program starts running, it attempts to communicate with the user-selected NAND flash chip. If this communication is successful and the main page size is acceptable, the nonerased page contents (non 0xFF) from the NAND flash page are dumped to the Dynamic C **STDIO** win. for inspection.

Note that an error message might appear when the first 32 pages (0x20 pages) are “dumped.” You may ignore the error message.

- **NFLASH\_INSPECT.c**—This program is a utility for inspecting the contents of a NAND flash chip. When the sample program starts running, it attempts to communicate with the NAND flash chip selected by the user. Once a NAND flash chip is found, the user can execute various commands to print out the contents of a specified page, clear (set to zero) all the bytes in a specified page, erase (set to FF), or write to specified pages.

**CAUTION:** When you run this sample program, enabling the **#define NFLASH\_CANERASEBADBLOCKS** macro makes it possible to write to bad blocks. The first two blocks on the *xD-Picture Card* are marked bad to protect the configuration data needed to use the card in a digital camera or a PC. You will only be able to use the *xD-Picture Card* in Rabbit-based systems if either of the first two blocks is written to.

- **NFLASH\_LOG.c**—This program runs a simple Web server and stores a log of hits in the NAND flash. As long as the *xD-Picture Card* is plugged in to its connector J6, this sample program will log hits to the *xD-Picture Card*. Remove the *xD-Picture Card* if you wish to log hits on the soldered-in NAND flash (RCM3365 model only).

This log can be viewed and cleared from a browser by connecting the RJ-45 jack on the RCM3365 to your PC as described in Section 6.1. The sidebar on the next page explains how to set up your PC or notebook to view this log.

Follow these instructions to set up your PC or notebook. Check with your administrator if you are unable to change the settings as described here since you may need administrator privileges. The instructions are specifically for Windows 2000, but the interface is similar for other versions of Windows.

**TIP:** If you are using a PC that is already on a network, you will disconnect the PC from that network to run these sample programs. Write down the existing settings before changing them to facilitate restoring them when you are finished with the sample programs and reconnect your PC to the network.

1. Go to the control panel (**Start > Settings > Control Panel**), and then double-click the Network icon.
2. Select the network interface card used for the Ethernet interface you intend to use (e.g., **TCP/IP Xircom Credit Card Network Adapter**) and click on the “Properties” button. Depending on which version of Windows your PC is running, you may have to select the “Local Area Connection” first, and then click on the “Properties” button to bring up the Ethernet interface dialog. Then “Configure” your interface card for a “10Base-T Half-Duplex” or an “Auto-Negotiation” connection on the “Advanced” tab.

**NOTE:** Your network interface card will likely have a different name.

3. Now select the **IP Address** tab, and check **Specify an IP Address**, or select TCP/IP and click on “Properties” to assign an IP address to your computer (this will disable “obtain an IP address automatically”):

IP Address : 10.10.6.101

Netmask : 255.255.255.0

Default gateway : 10.10.6.1

4. Click **<OK>** or **<Close>** to exit the various dialog boxes.

As long as you have not modified the **TCPCONFIG 1** macro in the sample program, enter the following server address in your Web browser to bring up the Web page served by the sample program.

`http://10.10.6.100`

Otherwise use the TCP/IP settings you entered in the **TCP\_CONFIG.LIB** library.

This sample program does not exhibit ideal behavior in its method of writing to the NAND flash. However, the inefficiency attributable to the small amount of data written in each append operation is offset somewhat by the expected relative infrequency of these writes, and by the sample program's method of “walking” through the flash blocks when appending data as well as when a log is cleared.

- **NFLASH\_ERASE.c**—This program is a utility to erase all the good blocks on a NAND flash chip. When the program starts running, it attempts to establish communication with the NAND flash chip selected by the user. If the communication is successful, the progress in erasing the blocks is displayed in the Dynamic C **STDIO** window as the blocks are erased.

### 3.2.2 Hot-Swapping xD-Picture Card

The sample programs in this section require that you have installed the Dynamic C FAT File System module, which is included with the RCM3365/RCM3375 Development Kit. Visit our Web site at [www.rabbit.com](http://www.rabbit.com) or contact your Rabbit sales representative or authorized distributor for further information on the Dynamic C FAT File System and other Dynamic C modules.

**NOTE:** Versions of the Dynamic C FAT File System prior to 2.10 did not use unique volume labels, so hot-swapping two *xD-Picture Card* that were both formatted with older versions of the FAT File System may cause cache recovery errors

The following sample program can be found in the **SAMPLES\RCM3360\NANDFlash** folder. Since Rabbit-based systems do not implement the *xD-Picture Card*<sup>™</sup> specification for data storage, hot-swap only *xD-Picture Cards* that you plan to have formatted for use in Rabbit-based systems.

- **FAT\_HOT\_SWAP\_3365\_75.c**—This program demonstrates how to hot-swap the *xD-Picture Card* on the RCM3365/RCM3375. Once you have compiled the sample program and it is running, press switch SW3 on the Prototyping Board or press any keyboard key on your PC to signal your intent to do a hot-swap. Remove the *xD-Picture Card* and insert a new *xD-Picture Card* (or replace the original one) when prompted to do so in the Dynamic C **STDIO** window or when the green LED (DS4) on the Prototyping Board lights up. Do not remove the *xD-Picture Card* until you are prompted or signaled by the LED!

The the *xD-Picture Card* can only be hot-swapped when the *xD-Picture Card* is “unmounted.” This sample program “unmounts” the *xD-Picture Card* when it detects a keyboard hit or SW3 press. Then it waits for a new *xD-Picture Card* to be inserted.

The following sample program can be found in the **SAMPLES\FileSystem\** folder.

- **FAT\_HOT\_SWAP.c**—This program demonstrates how to hot-swap the *xD-Picture Card* on boards that support the *xD-Picture Card* and have their data bus buffered. Once you have compiled the sample program and it is running, press any keyboard key on your PC to signal your intent to do a hot-swap. Remove the *xD-Picture Card* and insert a new *xD-Picture Card* (or replace the original one) when prompted to do so in the Dynamic C **STDIO** window. Do not remove the *xD-Picture Card* until you are prompted!

The *xD-Picture Card* can only be hot-swapped when the *xD-Picture Card* is “unmounted.” This sample program “unmounts” the *xD-Picture Card* when it detects a keyboard press. Then it waits for a new *xD-Picture Card* to be inserted.

### 3.2.3 Serial Communication

The following sample programs can be found in the `SAMPLES\RCM3360\SERIAL` folder.

- **FLOWCONTROL.C**—This program demonstrates hardware flow control by configuring Serial Port F for CTS/RTS with serial data coming from TxE (Serial Port E) at 115,200 bps. One character at a time is received and is displayed in the **STDIO** window.

To set up the Prototyping Board, you will need to tie TxE and RxE together on the RS-232 header at J14, and you will also tie TxF and RxF together as shown in the diagram.

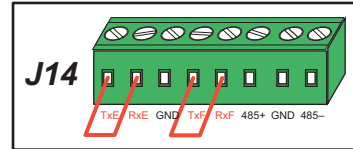

A repeating triangular pattern should print out in the **STDIO** window. The program periodically switches RTS (TxF) flow control on or off to demonstrate the effect of hardware flow control.

- **PARITY.C**—This program demonstrates the use of parity modes by repeatedly sending byte values 0–127 from Serial Port E to Serial Port F. The program will switch between generating parity or not on Serial Port E. Serial Port F will always be checking parity, so parity errors should occur during every other sequence.

To set up the Prototyping Board, you will need to tie TxE and RxF together on the RS-232 header at J14 as shown in the diagram.

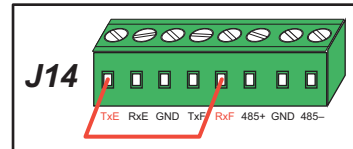

The Dynamic C **STDIO** window will display the error sequence.

- **SIMPLE3WIRE.C**—This program demonstrates basic RS-232 serial communication. Lower case characters are sent by TxE, and are received by RxF. The characters are converted to upper case and are sent out by TxF, are received by RxE, and are displayed in the Dynamic C **STDIO** window.

To set up the Prototyping Board, you will need to tie TxE and RxF together on the RS-232 header at J14, and you will also tie RxE and TxF together as shown in the diagram.

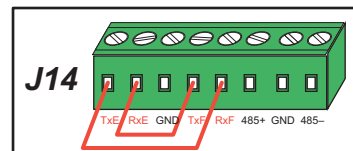

- **SIMPLE5WIRE.C**—This program demonstrates 5-wire RS-232 serial communication by providing flow control (RTS/CTS) on Serial Port F and data flow on Serial Port E.

To set up the Prototyping Board, you will need to tie TxE and RxE together on the RS-232 header at J14, and you will also tie TxF and RxF together as shown in the diagram.

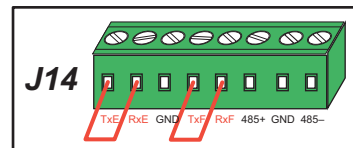

Once you have compiled and run this program, you can test flow control by disconnecting TxF from RxF while the program is running. Characters will no longer appear in the **STDIO** window, and will display again once TxF is connected back to RxF. (Do not disconnect the data path between TxE and RxE.)

- **SWITCHCHAR.C**—This program transmits and then receives an ASCII string on Serial Ports E and F. It also displays the serial data received from both ports in the **STDIO** window.

To set up the Prototyping Board, you will need to tie TxE and RxF together on the RS-232 header at J14, and you will also tie RxE and TxF together as shown in the diagram.

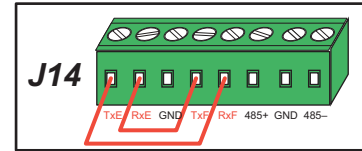

Once you have compiled and run this program, press and release S2 on the Prototyping Board to send a message from Serial Port E to Serial Port F; press and release S3 on the Prototyping Board to send a message from Serial Port F to Serial Port E. The data sent between the serial ports will be displayed in the **STDIO** window.

Two sample programs, **SIMPLE485MASTER.C** and **SIMPLE485SLAVE.C**, are available to illustrate RS-485 master/slave communication. To run these sample programs, you will need a second Rabbit-based system with RS-485—the second system may be another RCM3365/RCM3375, or it may be any Rabbit single-board computer or RabbitCore module that supports RS-485 serial communication as long as you use the master or slave sample program associated with that board.

Before running either of these sample programs on the RCM3365/RCM3375 assembly, make sure pins 1–2 and pins 5–6 are jumpered together on header JP5 to use the RS-485 bias and termination resistors. The sample programs use Serial Port C as the RS-485 serial port, and they use PD7 to enable/disable the RS-485 transmitter.

The RS-485 connections between the slave and master devices are as follows.

- RS485+ to RS485+
- RS485– to RS485–
- GND to GND
- **SIMPLE485MASTER.C**—This program demonstrates a simple RS-485 transmission of lower case letters to a slave. The slave will send back converted upper case letters back to the master and display them in the **STDIO** window. Use **SIMPLE485SLAVE.C** to program the slave—reset the slave before you run **SIMPLE485MASTER.C** on the master.
- **SIMPLE485SLAVE.C**—This program demonstrates a simple RS-485 transmission of lower case letters to a master. The slave will send back converted upper case letters back to the master and display them in the **STDIO** window. Compile and run this program on the slave before you use **SIMPLE485MASTER.C** to program the master.

### 3.2.4 Real-Time Clock

If you plan to use the real-time clock functionality in your application, you will need to set the real-time clock. Set the real-time clock using the **SETRTCKB.C** sample program from the Dynamic C **SAMPLES\RTCLOCK** folder, using the onscreen prompts. The **RTC\_TEST.C** sample program in the Dynamic C **SAMPLES\RTCLOCK** folder provides additional examples of how to read and set the real-time clock.

### 3.2.5 RabbitNet

Sample programs are available for each RabbitNet peripheral card, and can be found in the Dynamic C `SAMPLES\RabbitNet` folder. When you run any of these sample programs in conjunction with the RCM3365/RCM3375 and the Prototyping Board, you need to add the line

```
#use rcm33xx.lib
```

at the beginning of the sample program.

**TIP:** You need to add `#use rcm33xx.lib` at the beginning of any sample program that is not in the Dynamic C `SAMPLES\RCM3360` folder.

### 3.2.6 Other Sample Programs

Section 6.6 describes the TCP/IP sample programs, and Appendix C.7 provides sample programs for the optional LCD/keypad module that can be installed on the Prototyping Board.



## 4. HARDWARE REFERENCE

Chapter 4 describes the hardware components and principal hardware subsystems of the RCM3365/RCM3375 modules. Appendix A, “RCM3365/RCM3375 Specifications,” provides complete physical and electrical specifications.

Figure 5 shows the Rabbit-based subsystems designed into the RCM3365/RCM3375.

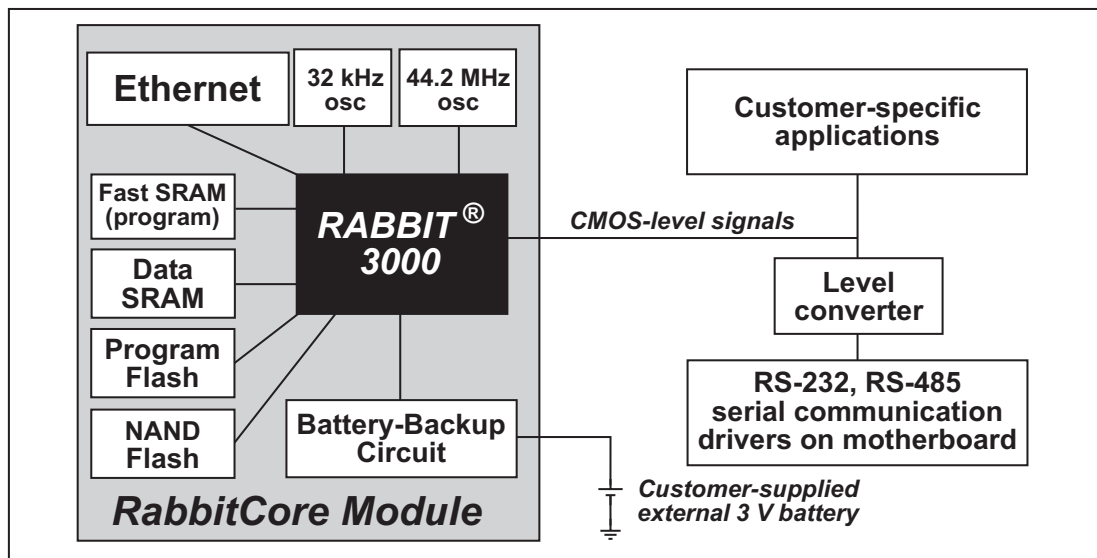

*Figure 5. RCM3365/RCM3375 Subsystems*

## 4.1 RCM3365/RCM3375 Inputs and Outputs

Figure 6 shows the RCM3365/RCM3375 pinouts for headers J3 and J4.

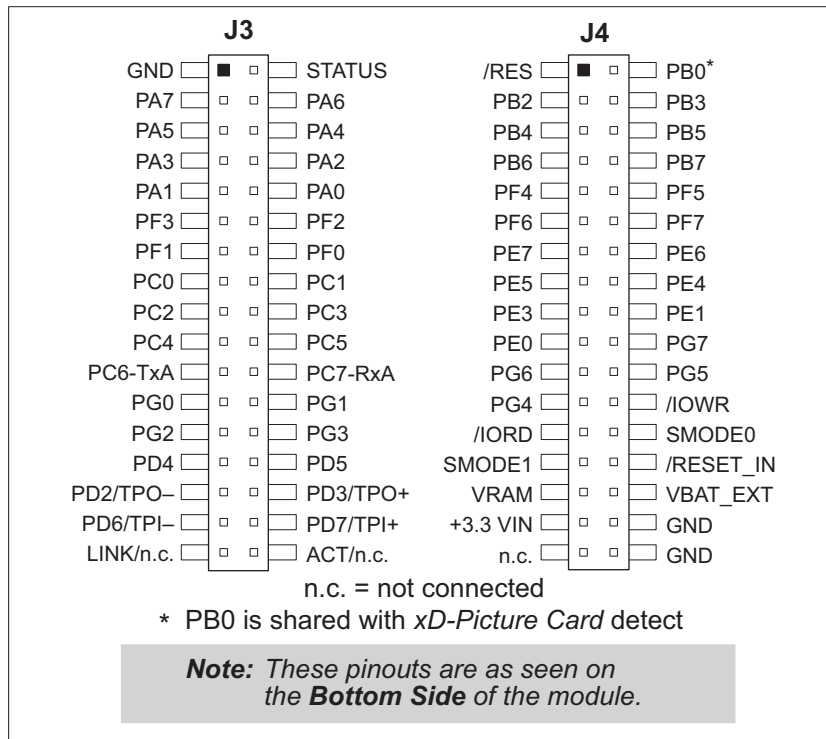

**Figure 6. RCM3365/RCM3375 Pinouts**

The pinouts for the RCM3000, RCM3100, RCM3200, RCM3300/RCM3310, RCM3360/RCM3370, and RCM3365/RCM3375 are almost compatible, except signals PB0, PC4, and PC5. PB0, PC4, and PC5 are used for the SPI interface to the serial flash on the RCM3300 and the RCM3310, but are available on the other modules. PB0 on the RCM3365 and the RCM3375 is used to sense whether the removable *xD-Picture Card* card is installed. If you need PB0 for other purposes, you may remove the surface-mount resistor at R96 (Figure A-5 shows the location of R96).

Headers J3 and J4 are standard  $2 \times 34$  headers with a nominal 2 mm pitch. An RJ-45 Ethernet port is also included with the RCM3365/RCM3375.

Pins 29–32 on header J3 are configured using  $0 \Omega$  resistors at locations JP4, JP5, JP7, and JP7 to be PD3, PD2, PD7, and PD6 respectively. They may also be reconfigured to carry the Ethernet signals TPO+, TPO–, TPI+, and TPI–.

Pins 33 and 34 on header J3 are wired to carry the **LINK** and **ACT** signals that illuminated the corresponding LEDs on the RCM3365/RCM3375 module. These signals may be “disconnected” by removing  $0 \Omega$  surface-mount resistors R41 and R42 (Figure A-5 shows the locations of R41 and R42).

Figure 7 shows the use of the Rabbit 3000 microprocessor ports in the RCM3365/RCM3375 modules.

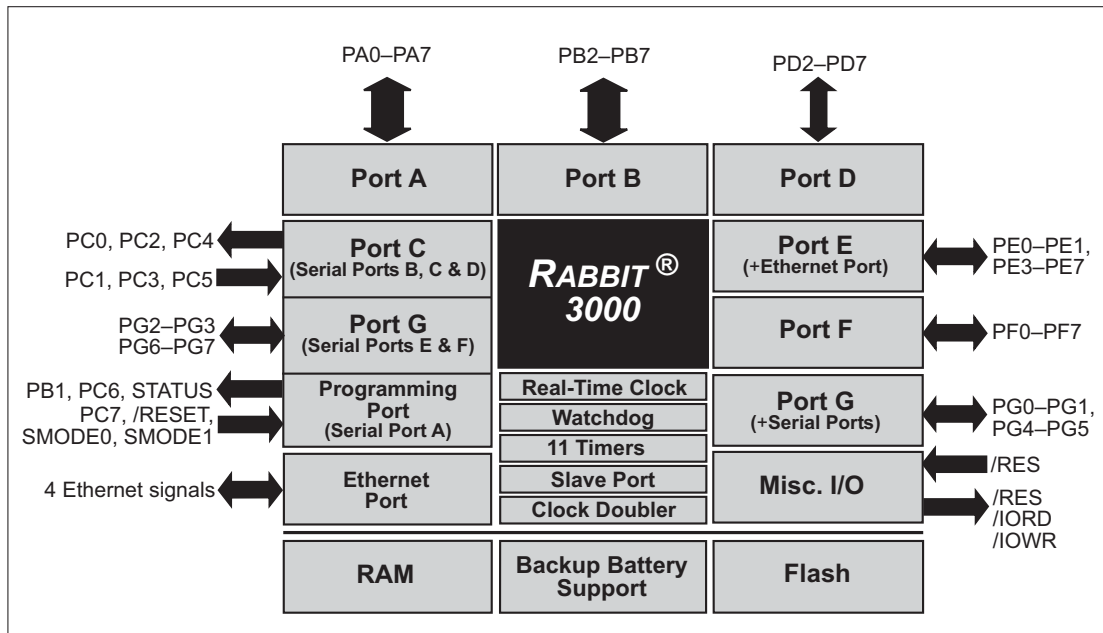

**Figure 7. Use of Rabbit 3000 Ports**

The ports on the Rabbit 3000 microprocessor used in the RCM3365/RCM3375 are configurable, and so the factory defaults can be reconfigured. Table 2 lists the Rabbit 3000 factory defaults and the alternate configurations.

**Table 2. RCM3365/RCM3375 Pinout Configurations**

Pin	Pin Name	Default Use	Alternate Use	Notes
1	GND			
2	STATUS	Output (Status)	Output	
3–10	PA[7:0]	Parallel I/O	External data bus (ID0–ID7) Slave port data bus (SD0–SD7)	External Data Bus
11	PF3	Input/Output	QD2A	
12	PF2	Input/Output	QD2B	
13	PF1	Input/Output	QD1A CLKC	
14	PF0	Input/Output	QD1B CLKD	
15	PC0	Output	TXD	Serial Port D
16	PC1	Input	RXD	
17	PC2	Output	TXC	Serial Port C
18	PC3	Input	RXC	
19	PC4	Output	TXB	Serial Port B
20	PC5	Input	RXB	
21	PC6	Output	TXA	Serial Port A (programming port)
22	PC7	Input	RXA	
23	PG0	Input/Output	TCLKF	Serial Clock F output
24	PG1	Input/Output	RCLKF	Serial Clock F input
25	PG2	Input/Output	TXF	Serial Port F
26	PG3	Input/Output	RXF	
27	PD4	Input/Output	ATXB	
28	PD5	Input/Output	ARXB	
29	PD2/TPO–	Input/Output	TPOUT– *	Optional Ethernet transmit port
30	PD3/TPO+	Input/Output	TPOUT+ *	
31	PD6/TPI–	Input/Output	TPIN– *	Optional Ethernet receive port
32	PD7/TPI+	Input/Output	TPIN+ *	
33	LINK	Output		Max. sinking current draw 1 mA (see Note 1)
34	ACT	Output		

\* Pins 29–32 are configured with 0 Ω surface-mount resistors at JP4, JP5, JP7, and JP8.

**Table 2. RCM3365/RCM3375 Pinout Configurations (continued)**

Pin	Pin Name	Default Use	Alternate Use	Notes	
Header J4	1	/RES	Reset output	Reset output from Reset Generator	
	2	PB0	Input/Output	CLKB	Used to detect presence of xD-Picture Card
	3	PB2	Input/Output	IA0 /SWR	External Address 0 Slave port write
	4	PB3	Input/Output	IA1 /SRD	External Address 1 Slave port read
	5	PB4	Input/Output	IA2 SA0	External Address 2 Slave port Address 0
	6	PB5	Input/Output	IA3 SA1	External Address 3 Slave port Address 1
	7	PB6	Input/Output	IA4	External Address 4
	8	PB7	Input/Output	IA5 /SLAVEATTN	External Address 5 Slave Attention
	9	PF4	Input/Output	AQD1B PWM0	
	10	PF5	Input/Output	AQD1A PWM1	
	11	PF6	Input/Output	AQD2B PWM2	
	12	PF7	Input/Output	AQD2A PWM3	
	13	PE7	Input/Output	I7 /SCS	I/O Strobe 7 Slave Port Chip Select
	14	PE6	Input/Output	I6	I/O Strobe 6
	15	PE5	Input/Output	I5 INT1B	I/O Strobe 5 Interrupt 1B
	16	PE4	Input/Output	I4 INT0B	I/O Strobe 4 Interrupt 0B
	17	PE3	Input/Output	I3	I/O Strobe 3
	18	PE1	Input/Output	I1 INT1A	I/O Strobe 1 Interrupt 1A
	19	PE0	Input/Output	I0 INT0A	I/O Strobe 0 Interrupt 0A

**Table 2. RCM3365/RCM3375 Pinout Configurations (continued)**

Pin	Pin Name	Default Use	Alternate Use	Notes	
Header J4	20	PG7	Input/Output	RXE	Serial Port E
	21	PG6	Input/Output	TXE	
	22	PG5	Input/Output	RCLKE	Serial Clock E input
	23	PG4	Input/Output	TCLKE	Serial Clock E ouput
	24	/IOWR	Output		External write strobe
	25	/IORD	Output		External read strobe
	26–27	SMODE0, SMODE1	(0,0)—start executing at address zero (0,1)—cold boot from slave port (1,0)—cold boot from clocked Serial Port A  SMODE0 =1, SMODE1 = 1 Cold boot from asynchronous Serial Port A at 2400 bps (programming cable connected)		Also connected to programming cable
	28	/RESET_IN	Input		Input to Reset Generator
	29	VRAM	Output		See <b>Notes</b> below table
	30	VBAT_EXT	3 V battery Input		Minimum battery voltage 2.85 V
	31	+3.3 VIN	Power Input		3.15–3.45 V DC
	32	GND			
	33	n.c.			Reserved for future use
	34	GND			

**Notes**

1. When using pins 33–34 on header J3 to drive LEDs, these pins can handle a sinking current of up to 8 mA.
2. The VRAM voltage is temperature-dependent. If the VRAM voltage drops below about 1.2 V to 1.5 V, the contents of the battery-backed SRAM may be lost. If VRAM drops below 1.0 V, the 32 kHz oscillator could stop running. Pay careful attention to this voltage if you draw any current from this pin.
3. Do not overload the /IOWR line because the NAND flash memories have critical timing requirements. In some cases it may be necessary to buffer /IOWR on the motherboard.

### 4.1.1 Memory I/O Interface

The Rabbit 3000 address lines (A0–A18) and all the data lines (D0–D7) are routed internally to the onboard flash memory and SRAM chips. I/O write (/IOWR) and I/O read (/IORD) are available for interfacing to external devices—pay attention to the loading on these two signals if you use them since these signals are also used by the RCM3365/RCM3375.

Parallel Port A can also be used as an external I/O data bus to isolate external I/O from the main data bus. Parallel Port B pins PB2–PB7 can also be used as an auxiliary address bus.

When using the external I/O bus for a digital output or the LCD/keypad module on the Prototyping Board, or for any other reason, you must add the following line at the beginning of your program.

```
#define PORTA_AUX_IO    // required to enable external I/O bus
```

### 4.1.2 Other Inputs and Outputs

The status, /RESET\_IN, SMODE0, and SMODE1 I/O are normally associated with the programming port. Since the status pin is not used by the system once a program has been downloaded and is running, the status pin can then be used as a general-purpose CMOS output. The programming port is described in more detail in Section 4.2.3.

/RES is an output from the reset circuitry that can be used to reset external peripheral devices.

### 4.1.3 LEDs

The RCM3365/RCM3375 has five status LEDs located beside the RJ-45 Ethernet jack: **ACT**, **LINK**, **SPEED**, **FM**, and **USR**.

The yellow **ACT** LED at DS1 indicates network activity.

The green **LINK** LED at DS2 indicates that the RCM3365/RCM3375 is connected to a working network.

The green **SPEED** LED at DS4 is on to indicate when the RCM3365/RCM3375 is connected to a 100Base-T Ethernet connection.

The **FM** LED at DS3 blinks when data are being written to or read from the flash mass-storage device.

The red **USR** LED at DS3 is a user-programmable LED, which is controlled by PD0 on the Rabbit 3000's Parallel Port D. The sample program **FLASHLED.C** provided in the Dynamic C **SAMPLES\RCM3360** folder shows how to set up and use this user-programmable LED.

## 4.2 Serial Communication

The RCM3365/RCM3375 does not have any serial transceivers directly on the board. However, a serial interface may be incorporated into the board the RCM3365/RCM3375 is mounted on. For example, the Prototyping Board has RS-232 and RS-485 transceiver chips.

### 4.2.1 Serial Ports

There are six serial ports designated as Serial Ports A, B, C, D, E, and F. All six serial ports can operate in an asynchronous mode up to the baud rate of the system clock divided by 8. An asynchronous port can handle 7 or 8 data bits. A 9th bit address scheme, where an additional bit is sent to mark the first byte of a message, is also supported.

Serial Port A is normally used as a programming port, but may be used either as an asynchronous or as a clocked serial port once the RCM3365/RCM3375 has been programmed and is operating in the Run Mode.

Serial Port B is available on the RCM3365/RCM3375, and may be used as an asynchronous port. PB0 is used to enable Dynamic C to detect whether the *xD-Picture Card* is installed. If the card detect is not needed by your application program, you may remove R96 (see Figure A-5) to disable the *xD-Picture Card* detect, and then use Serial Port B as a clocked serial port.

Serial Ports C and D can also be operated in the clocked serial mode. In this mode, a clock line synchronously clocks the data in or out. Either of the two communicating devices can supply the clock.

Serial Ports E and F can also be configured as HDLC serial ports. The IrDA protocol is also supported in SDLC format by these two ports.

### 4.2.2 Ethernet Port

Figure 8 shows the pinout for the RJ-45 Ethernet port (J2). Note that some Ethernet connectors are numbered in reverse to the order used here.

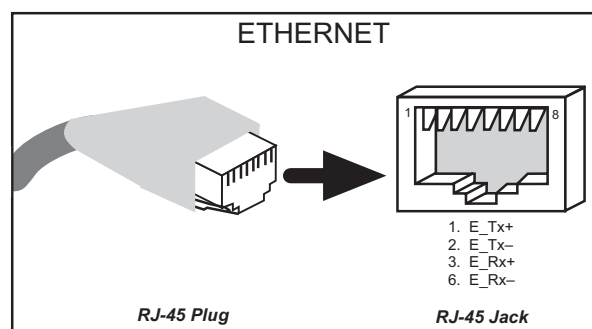

**Figure 8. RJ-45 Ethernet Port Pinout**

Three LEDs are placed next to the RJ-45 Ethernet jack, one to indicate an Ethernet link (**LINK**) one to indicate Ethernet activity (**ACT**), and one to indicate the 10/100Base-T speed. The RJ-45 connector is shielded to minimize EMI effects to/from the Ethernet signals.



### 4.2.3 Serial Programming Port

The RCM3365/RCM3375 is programmed either through the serial programming port, which is accessed using header J1 or through the Ethernet jack. The RabbitLink may be used to provide a serial connection via the RabbitLink's Ethernet jack. The programming port uses the Rabbit 3000's Serial Port A for communication; Serial Port A is not used when programming is done over an Ethernet connection on a board running Dynamic C RabbitSys. Dynamic C uses the programming port to download and debug programs.

The programming port is also used for the following operations.

- Cold-boot the Rabbit 3000 on the RCM3365/RCM3375 after a reset.
- Remotely download and debug a program over an Ethernet connection using the RabbitLink EG2110.
- Fast copy designated portions of flash memory from one Rabbit-based board (the master) to another (the slave) using the Rabbit Cloning Board.

In addition to Serial Port A, the Rabbit 3000 startup-mode (SMODE0, SMODE1), status, and reset pins are available on the programming port.

The two startup mode pins determine what happens after a reset—the Rabbit 3000 is either cold-booted or the program begins executing at address 0x0000.

The status pin is used by Dynamic C to determine whether a Rabbit microprocessor is present. The status output has three different programmable functions:

1. It can be driven low on the first op code fetch cycle.
2. It can be driven low during an interrupt acknowledge cycle.
3. It can also serve as a general-purpose CMOS output.

The /RESET\_IN pin is an external input that is used to reset the Rabbit 3000 and the RCM3365/RCM3375 onboard peripheral circuits. The serial programming port can be used to force a hard reset on the RCM3365/RCM3375 by asserting the /RESET\_IN signal. No equivalent functionality exists for programming over an Ethernet connection on a board running Dynamic C RabbitSys.

#### Alternate Uses of the Serial Programming Port

All three clocked Serial Port A signals are available as

- a synchronous serial port
- an asynchronous serial port, with the clock line usable as a general CMOS I/O pin

The programming port may also be used as a serial port once the application is running. The SMODE pins may then be used as inputs and the status pin may be used as an output.

Refer to the *Rabbit 3000 Microprocessor User's Manual* for more information.

### 4.3 Serial Programming Cable

The programming cable is used to connect the serial programming port of the RCM3365/RCM3375 to a PC serial COM port. The programming cable converts the RS-232 voltage levels used by the PC serial port to the CMOS voltage levels used by the Rabbit 3000.

When the **PROG** connector on the programming cable is connected to the RCM3365/RCM3375 serial programming port at header J1, programs can be downloaded and debugged over the serial interface.

The **DIAG** connector of the programming cable may be used on header J1 of the RCM3365/RCM3375 with the RCM3365/RCM3375 operating in the Run Mode. This allows the programming port to be used as a regular serial port.

#### 4.3.1 Changing Between Program Mode and Run Mode

The RCM3365/RCM3375 is automatically in Program Mode when the **PROG** connector on the programming cable is attached, and is automatically in Run Mode when no programming cable is attached. When the Rabbit 3000 is reset, the operating mode is determined by the state of the SMODE pins. When the programming cable's **PROG** connector is attached, the SMODE pins are pulled high, placing the Rabbit 3000 in the Program Mode. When the programming cable's **PROG** connector is not attached, the SMODE pins are pulled low, causing the Rabbit 3000 to operate in the Run Mode.

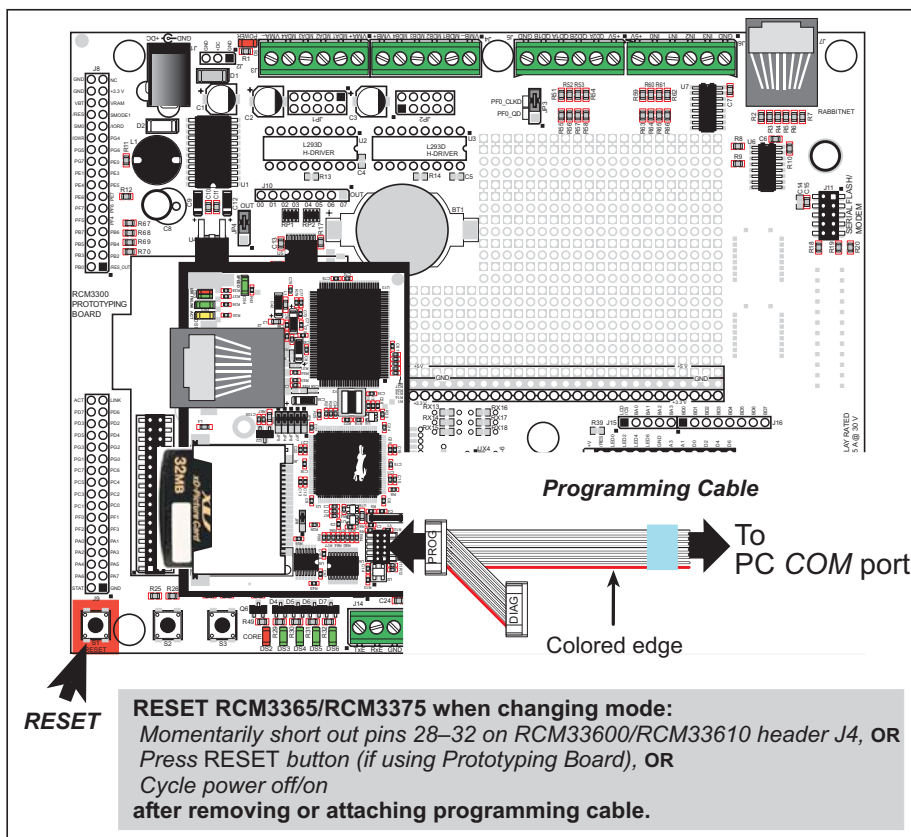

Figure 9. Switching Between Program Mode and Run Mode

A program “runs” in either mode, but can only be downloaded and debugged when the RCM3365/RCM3375 is in the Program Mode.

Refer to the *Rabbit 3000 Microprocessor User’s Manual* for more information on the programming port.

#### **4.3.2 Standalone Operation of the RCM3365/RCM3375**

The RCM3365/RCM3375 must be programmed via the Prototyping Board or via a similar arrangement on a customer-supplied board. Once the RCM3365/RCM3375 has been programmed successfully, remove the serial programming cable from the programming connector and reset the RCM3365/RCM3375. The RCM3365/RCM3375 may be reset by cycling the power off/on or by pressing the **RESET** button on the Prototyping Board. The RCM3365/RCM3375 module may now be removed from the Prototyping Board for end-use installation.

**CAUTION:** Disconnect power to the Prototyping Board or other boards when removing or installing your RCM3365/RCM3375 module to protect against inadvertent shorts across the pins or damage to the RCM3365/RCM3375 if the pins are not plugged in correctly. Do not reapply power until you have verified that the RCM3365/RCM3375 module is plugged in correctly.

## 4.4 Memory

### 4.4.1 SRAM

RCM3365/RCM3375 boards have 512K of program-execution fast SRAM at U11. The program-execution SRAM is not battery-backed. There are 512K of battery-backed data SRAM installed at U10.

### 4.4.2 Flash EPROM

RCM3365/RCM3375 boards also have 512K of flash EPROM at U9.

**NOTE:** Rabbit recommends that any customer applications should not be constrained by the sector size of the flash EPROM since it may be necessary to change the sector size in the future.

Writing to arbitrary flash memory addresses at run time is also discouraged. Instead, use a portion of the “user block” area to store persistent data. The functions **writeUserBlock** and **readUserBlock** are provided for this. Refer to the *Rabbit 3000 Microprocessor Designer’s Handbook* and the *Dynamic C Function Reference Manual* for additional information.

### 4.4.3 NAND Flash

The RCM3365 and the RCM3375 support a removable *xD-Picture Card*<sup>™</sup> to store data and Web pages. The RCM3365 and the RCM3375 both can handle up to a 128MB removable *xD-Picture Card*, and the RCM3365 model also has a 32MB onboard NAND flash.\*

**NOTE:** Rabbit-based systems do not implement the *xD-Picture Card*<sup>™</sup> specification for data storage, and are neither compatible nor compliant with *xD-Picture Card*<sup>™</sup> card readers.

The NAND flash and *xD-Picture Card* are particularly suitable for mass-storage applications, but are generally unsuitable for direct program execution. The NAND flash differs from parallel NOR flash (the type of flash memory used to store program code on Rabbit-based boards and RabbitCore modules currently in production) in two respects. First, the NAND flash requires error-correcting code (ECC) for reliability. Although NAND flash manufacturers do guarantee that block 0 will be error-free, most manufacturers guarantee that a new NAND flash chip will be shipped with a relatively small percentage of errors, and will not develop more than some maximum number or percentage of errors over its rated lifetime of up to 100,000 writes. Second, the standard NAND flash addressing method multiplexes commands, data, and addresses on the same I/O pins, while requiring that certain control lines must be held stable for the duration of the NAND flash access. The software function calls provided by Rabbit for the NAND flash take care of the data-integrity and reliability attributes.

---

\* RCM3365 modules sold before 2008 had 16MB fixed NAND flash memory.

Figure 10 shows how to insert or remove the *xD-Picture Card*. While you remove or insert the *xD-Picture Card*, take care to avoid touching the electrical contacts on the bottom of the card to prevent electrostatic discharge damage to the card and to keep any moisture or other contaminants off the contacts. Do **not** remove or insert the *xD-Picture Card* while it is being accessed.

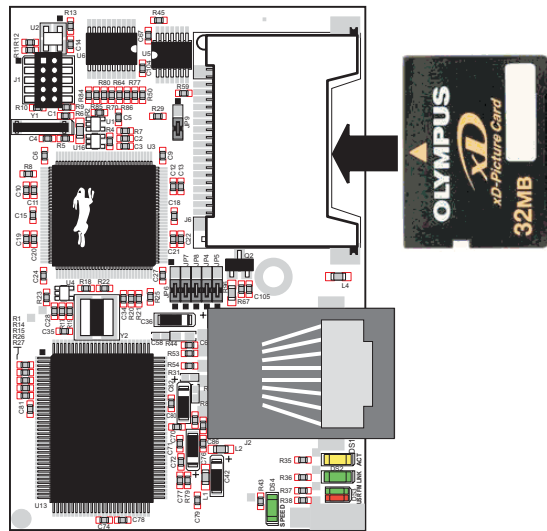

**Figure 10. Insertion/Removal of *xD-Picture Card***

It is possible to hot-swap *xD-Picture Cards* without removing power from the RCM3365/RCM3375 module. The file system must be closed before the cards can be hot-swapped. The chip selects associated with the NAND flash and the *xD-Picture Card* must be set to their inactive state, and read/write operations addressed to the NAND flash area cannot be allowed to occur. These operations can be initiated in software by sensing an external switch actuated by the user, and the *xD-Picture Card* can then be removed and replaced with a different one. Once the application program detects a new card, the file system can be opened. These steps allow the *xD-Picture Card* to be installed or removed without affecting either the program, which continues to run on the RCM3365/RCM3375 module, or the data stored on the *xD-Picture Card*.

The `FAT_HOT_SWAP_336x0.C` sample program in the `SAMPLES\FileSystem\` folder illustrates this hot-swapping procedure.

Rabbit recommends that you use header J6 only for the *xD-Picture Card* since other devices are not supported. Be careful to remove and insert the *xD-Picture Card* as shown, and be careful **not** to insert any foreign objects, which may short out the contacts and lead to the destruction of your *xD-Picture Card*.

Sample programs in the `SAMPLES\RCM3360\NANDFlash` folder illustrate the use of the NAND flash. These sample programs are described in Section 3.2.1, “Use of NAND Flash.” Pay careful attention to the sample programs to see how to close files and secure any data on the *xD-Picture Card* before you remove it.

## 4.5 Other Hardware

### 4.5.1 Clock Doubler

The RCM3365/RCM33610 takes advantage of the Rabbit 3000 microprocessor's internal clock doubler. A built-in clock doubler allows half-frequency crystals to be used to reduce radiated emissions. The 44.2 MHz frequency specified for the RCM3365/RCM3375 is generated using a 22.12 MHz resonator.

The clock doubler may be disabled if 44.2 MHz clock speeds are not required. This will reduce power consumption and further reduce radiated emissions. The clock doubler is disabled with a simple configuration macro as shown below.

1. Select the “Defines” tab from the Dynamic C **Options > Project Options** menu.
2. Add the line `CLOCK_DOUBLED=0` to always disable the clock doubler.

The clock doubler is enabled by default, and usually no entry is needed. If you need to specify that the clock doubler is always enabled, add the line `CLOCK_DOUBLED=1` to always enable the clock doubler.

3. Click **OK** to save the macro. The clock doubler will now remain off whenever you are in the project file where you defined the macro.

### 4.5.2 Spectrum Spreader

The Rabbit 3000 features a spectrum spreader, which helps to mitigate EMI problems. The spectrum spreader is on by default, but it may also be turned off or set to a stronger setting. The means for doing so is through a simple configuration macro as shown below.

1. Select the “Defines” tab from the Dynamic C **Options > Project Options** menu.
2. Normal spreading is the default, and usually no entry is needed. If you need to specify normal spreading, add the line

```
ENABLE_SPREADER=1
```

For strong spreading, add the line

```
ENABLE_SPREADER=2
```

To disable the spectrum spreader, add the line

```
ENABLE_SPREADER=0
```

**NOTE:** The strong spectrum-spreading setting is not recommended since it may limit the maximum clock speed or the maximum baud rate. It is unlikely that the strong setting will be used in a real application.

3. Click **OK** to save the macro. The spectrum spreader will now be set to the state specified by the macro value whenever you are in the project file where you defined the macro.

**NOTE:** Refer to the *Rabbit 3000 Microprocessor User's Manual* for more information on the spectrum-spreading setting and the maximum clock speed.

## 5. SOFTWARE REFERENCE

Dynamic C is an integrated development system for writing embedded software. It runs on an IBM-compatible PC and is designed for use with Rabbit controllers and other controllers based on the Rabbit microprocessor. Chapter 5 describes the libraries and function calls related to the RCM3365/RCM3375.

### 5.1 More About Dynamic C

Dynamic C has been in use worldwide since 1989. It is specially designed for programming embedded systems, and features quick compile and interactive debugging. A complete reference guide to Dynamic C is contained in the *Dynamic C User's Manual*.

You have a choice of doing your software development in the flash memory or in the static SRAM included on the RCM3365/RCM3375. The flash memory and SRAM options are selected with the **Options > Program Options > Compiler** menu.

The advantage of working in RAM is to save wear on the flash memory, which is limited to about 100,000 write cycles. The disadvantage is that the code and data might not both fit in RAM.

**NOTE:** An application should be run from the program execution SRAM after the serial programming cable is disconnected. Your final code must always be stored in flash memory for reliable operation. RCM3365/RCM3375 modules running at 44.2 MHz have a fast program execution SRAM that is not battery-backed. Select **Code and BIOS in Flash, Run in RAM** from the Dynamic C **Options > Project Options > Compiler** menu to store the code in flash and copy it to the fast program execution SRAM at run-time to take advantage of the faster clock speed. This option optimizes the performance of RCM3365/RCM3375 modules running at 44.2 MHz.

**NOTE:** Do not depend on the flash memory sector size or type in your program logic. The RCM3365/RCM3375 and Dynamic C were designed to accommodate flash devices with various sector sizes in response to the volatility of the flash-memory market.

Developing software with Dynamic C is simple. Users can write, compile, and test C and assembly code without leaving the Dynamic C development environment. Debugging occurs while the application runs on the target. Alternatively, users can compile a program to an image file for later loading. Dynamic C runs on PCs under Windows 2000/NT and later—see Rabbit's Technical Note TN257, *Running Dynamic C® With Windows Vista®*,

for additional information if you are using a Dynamic C release prior to v. 9.60 under Windows Vista. Programs can be downloaded at baud rates of up to 460,800 bps after the program compiles.

Dynamic C has a number of standard features.

- Full-feature source and/or assembly-level debugger, no in-circuit emulator required.
- Royalty-free TCP/IP stack with source code and most common protocols.
- Hundreds of functions in source-code libraries and sample programs:
  - ▶ Exceptionally fast support for floating-point arithmetic and transcendental functions.
  - ▶ RS-232 and RS-485 serial communication.
  - ▶ Analog and digital I/O drivers.
  - ▶ I<sup>2</sup>C, SPI, GPS, file system.
  - ▶ LCD display and keypad drivers.
- Powerful language extensions for cooperative or preemptive multitasking
- Loader utility program to load binary images into Rabbit targets in the absence of Dynamic C.
- Provision for customers to create their own source code libraries and augment on-line help by creating “function description” block comments using a special format for library functions.
- Standard debugging features:
  - ▶ Breakpoints—Set breakpoints that can disable interrupts.
  - ▶ Single-stepping—Step into or over functions at a source or machine code level,  $\mu$ C/OS-II aware.
  - ▶ Code disassembly—The disassembly window displays addresses, opcodes, mnemonics, and machine cycle times. Switch between debugging at machine-code level and source-code level by simply opening or closing the disassembly window.
  - ▶ Watch expressions—Watch expressions are compiled when defined, so complex expressions including function calls may be placed into watch expressions. Watch expressions can be updated with or without stopping program execution.
  - ▶ Register window—All processor registers and flags are displayed. The contents of general registers may be modified in the window by the user.
  - ▶ Stack window—shows the contents of the top of the stack.
  - ▶ Hex memory dump—displays the contents of memory at any address.
  - ▶ **STDIO** window—`printf` outputs to this window and keyboard input on the host PC can be detected for debugging purposes. `printf` output may also be sent to a serial port or file.



### 5.1.1 Developing Programs Remotely with Dynamic C

Dynamic C is an integrated development environment that allows you to edit, compile, and debug your programs. Dynamic C has the ability to allow programming over the Internet or local Ethernet. This is accomplished in one of three ways.

1. RCM3365 RabbitCore modules that are preloaded with Dynamic C RabbitSys firmware can be used with Dynamic C RabbitSys to be accessed via an Ethernet connection for remote application updates, and for remote monitoring and control. Dynamic C RabbitSys requires Dynamic C version 9.30 or later, and allows the RCM3365. The *Dynamic C RabbitSys User's Manual* provides complete information on RabbitSys.
2. Via the Rabbit RabbitLink, which allows a Rabbit-based target to have programs downloaded to it and debugged with the same ease as exists when the target is connected directly to a PC.
3. Dynamic C provides sample programs to illustrate the use of a download manager, but these sample programs are not intended for use with the NAND flash on the RCM3365 and RCM3375 RabbitCore modules. The `DLM_TCP.C` and `DLP_TCP.C` sample programs found in the Dynamic C `SAMPLES\DOWN_LOAD` folder, are intended to be compiled to the program flash memory (which is a parallel flash memory). Custom applications based on these sample programs may use the NAND flash for data storage.

## 5.2 Dynamic C Functions

### 5.2.1 Digital I/O

The RCM3365/RCM3375 was designed to interface with other systems, and so there are no drivers written specifically for the I/O. The general Dynamic C read and write functions allow you to customize the parallel I/O to meet your specific needs. For example, use

```
WrPortI(PEDDR, &PEDDRShadow, 0x00);
```

to set all the Port E bits as inputs, or use

```
WrPortI(PEDDR, &PEDDRShadow, 0xFF);
```

to set all the Port E bits as outputs.

When using the external I/O bus on the Rabbit 3000 chip, add the line

```
#define PORTA_AUX_IO // required to enable external I/O bus
```

to the beginning of any programs using the external I/O bus.

The sample programs in the Dynamic C **SAMPLES/RCM3360** folder provide further examples.

### 5.2.2 SRAM Use

The RCM3365/RCM3375 have a battery-backed data SRAM and a program-execution SRAM. Dynamic C provides the **protected** keyword to identify variables that are to be placed into the battery-backed SRAM. The compiler generates code that maintains two copies of each protected variable in the battery-backed SRAM. The compiler also generates a flag to indicate which copy of the protected variable is valid at the current time. This flag is also stored in the battery-backed SRAM. When a protected variable is updated, the “inactive” copy is modified, and is made “active” only when the update is 100% complete. This assures the integrity of the data in case a reset or a power failure occurs during the update process. At power-on the application program uses the active copy of the variable pointed to by its associated flag.

The sample code below shows how a protected variable is defined and how its value can be restored.

```
protected nf_device nandFlash;
int main() {
    ...
    _sysIsSoftReset(); // restore any protected variables
```

The **bbram** keyword may also be used instead if there is a need to store a variable in battery-backed SRAM without affecting the performance of the application program. Data integrity is *not* assured when a reset or power failure occurs during the update process.

Additional information on **bbram** and **protected** variables is available in the *Dynamic C User's Manual*.

### 5.2.3 Serial Communication Drivers

Library files included with Dynamic C provide a full range of serial communications support. The **RS232.LIB** library provides a set of circular-buffer-based serial functions. The **PACKET.LIB** library provides packet-based serial functions where packets can be delimited by the 9th bit, by transmission gaps, or with user-defined special characters. Both libraries provide blocking functions, which do not return until they are finished transmitting or receiving, and nonblocking functions, which must be called repeatedly until they are finished, allowing other functions to be performed between calls. For more information, see the *Dynamic C Function Reference Manual* and Technical Note TN213, *Rabbit Serial Port Software*.

### 5.2.4 TCP/IP Drivers

The TCP/IP drivers are located in the **LIB\TCPIP** folder. Complete information on these libraries and the TCP/IP functions is provided in the *Dynamic C TCP/IP User's Manual*.

### 5.2.5 NAND Flash Drivers

The Dynamic C **NANDFlash\NFLASH.LIB** library is used to interface to NAND flash memory devices on the RCM3365 and the RCM3375. The function calls were written specifically to work with industry-standard flash devices with a 528-byte page program and 16896-byte block erase size. The NAND flash function calls are designed to be closely cross-compatible with the newer serial flash function calls found in the **SFLASH.LIB** library. These function calls use an **nf\_device** structure as a handle for a specific NAND flash device. This allows multiple NAND flash devices to be used by an application.

More information on these function calls is available in the *Dynamic C Function Reference Manual*.

The NAND flash and the *xD-Picture Card* are ideally suited to store files with a directory structure. The Dynamic C FAT file system module provides support for a file system and for formatting the *xD-Picture Card* for use in a Rabbit-based system. Visit our Web site at [www.rabbit.com](http://www.rabbit.com) or contact your Rabbit sales representative or authorized distributor for further information on the Dynamic C FAT File System and other Dynamic C modules. The supporting documentation for the Dynamic C FAT File System and the sample programs in the **SAMPLES\FileSystem\** folder illustrate the use of the Dynamic C FAT file system.

## 5.2.6 Prototyping Board Functions

The functions described in this section are for use with the Prototyping Board features. The source code is in the Dynamic C `SAMPLES\RCM3300\RCM33xx.LIB` library if you need to modify it for your own board design.

The `RCM33xx.LIB` library is supported by the `RN_CFG_RCM33.LIB`—library, which is used to configure the RCM3365/RCM3375 for use with RabbitNet peripheral boards on the Prototyping Board.

Other generic functions applicable to all devices based on Rabbit microprocessors are described in the *Dynamic C Function Reference Manual*.

### 5.2.6.1 Board Initialization

```
void brdInit (void);
```

Call this function at the beginning of your program. This function initializes Parallel Ports A through G for use with the Prototyping Board.

#### Summary of Initialization

1. I/O port pins are configured for Prototyping Board operation.
2. Unused configurable I/O are set as tied inputs or outputs.
3. External I/O are disabled.
4. The LCD/keypad module is disabled.
5. RS-485 is not enabled.
6. RS-232 is not enabled.
7. LEDs are off.
8. Ethernet select is disabled.
9. Mass-storage flash select is disabled.
10. Motor control is disabled.
11. The RabbitNet SPI interface is disabled.
12. The relay is set to normally closed positions.

#### RETURN VALUE

None.

### 5.2.6.2 Digital I/O

```
int digIn(int channel);
```

Reads the input state of inputs on Prototyping Board headers J5 and J6. Do not use this function if you configure these pins for alternate use after `brdInit()` is called.

#### PARAMETERS

`channel` is the channel number corresponding to the signal on header J5 or J6

- 0—IN0
- 1—IN1
- 2—IN2
- 3—IN3
- 4—QD1B
- 5—QD1A
- 6—QD2B
- 7—QD2A

#### RETURN VALUE

The logic state (0 or 1) of the input.

#### SEE ALSO

`brdInit`

```
void digOut(int channel, int value);
```

Writes a value to an output channel on Prototyping Board header J10. Do not use this function if you have installed the stepper motor chips at U2 and U3.

#### PARAMETERS

`channel` is output channel 0–7 (OUT00–OUT07).

`value` is the value (0 or 1) to output.

#### RETURN VALUE

None.

#### SEE ALSO

`brdInit`

### 5.2.6.3 Switches, LEDs, and Relay

```
int switchIn(int swin);
```

Reads the state of a switch input.

#### PARAMETERS

**swin** is the switch input to read:

2—S2

3—S3

#### RETURN VALUE

State of the switch input:

1 = open

0 = closed

#### SEE ALSO

`brdInit`

```
void ledOut(int led, int value);
```

Controls LEDs on the Prototyping Board and on the RCM3365/RCM3375.

#### PARAMETERS

**led** is the LED to control:

0 = red User LED on RCM3365/RCM3375

3 = DS3 on Prototyping Board

4 = DS4 on Prototyping Board

5 = DS5 on Prototyping Board

6 = DS6 on Prototyping Board

**value** is the value used to control the LED:

0 = off

1 = on

#### RETURN VALUE

None.

#### SEE ALSO

`brdInit`

```
void relayOut(int relay, int value);
```

Sets the position for the relay common contact. The default position is for normally closed contacts.

#### PARAMETERS

**relay** is the one relay (1)

**value** is the value used to connect the relay common contact:

0 = normally closed positions (NC1 and NC2)

1 = normally open positions (NO1 and NO2)

#### RETURN VALUE

None.

#### SEE ALSO

`brdInit`

### 5.2.6.4 Serial Communication

```
void ser485Tx(void);
```

Enables the RS-485 transmitter. Transmitted data are echoed back into the receive data buffer. The echoed data may be used as an indicator for disabling the transmitter by using one of the following methods:

Byte mode—disable the transmitter after the same byte that is transmitted is detected in the receive data buffer.

Block data mode—disable the transmitter after the same number of bytes transmitted are detected in the receive data buffer.

Remember to call the `serXopen()` function before running this function.

#### SEE ALSO

`ser485Rx`

```
void ser485Rx(void);
```

Disables the RS-485 transmitter. This puts the device into the listen mode, which allows it to receive data from the RS-485 interface.

Remember to call the `serXopen()` function before running this function.

#### SEE ALSO

`ser485Tx`

### 5.2.6.5 RabbitNet Port

The function calls described in this section are used to configure the RabbitNet port on the Prototyping Board for use with RabbitNet peripheral cards. The user's manual for the specific peripheral card you are using contains additional function calls related to the RabbitNet protocol and the individual peripheral card. Appendix F provides additional information about the RabbitNet.

These RabbitNet peripheral cards are available at the present time.

- Digital I/O Card (RN1100)
- Relay Card (RN1400)
- A/D Converter Card (RN1200)
- Keypad/Display Interface (RN1600)
- D/A Converter Card (RN1300)

Before using the RabbitNet port, add the following lines at the start of your program.

```
#define RN_MAX_DEV 10 // max number of devices
#define RN_MAX_DATA 16 // max number of data bytes in any transaction
#define RN_MAX_PORT 2 // max number of serial ports
```

Set the following bits in **RNSTATUSABORT** to abort transmitting data after the status byte is returned. This does not affect the status byte and still can be interpreted. Set any bit combination to abort:

```
bit 7—device busy is hard-coded into driver
bit 5—identifies router or slave
bits 4,3,2—peripheral-board-specific bits
bit 1—command rejected
bit 0—watchdog timeout

#define RNSTATUSABORT 0x80
// hard-coded driver default to abort if the peripheral board is busy
```

```
void rn_sp_info();
```

Provides **rn\_init()** with the serial port control information needed for RCM3365/RCM3375 modules.

#### RETURN VALUE

None.



```
void rn_sp_close(int port);
```

Deactivates the RCM3365/RCM3375 RabbitNet port as a clocked serial port. This call is also used by `rn_init()`.

**PARAMETERS**

`portnum = 0`

**RETURN VALUE**

None

```
void rn_sp_enable(int portnum);
```

This is a macro that enables or asserts the RCM3365/RCM3375 RabbitNet port chip select prior to data transfer.

**PARAMETERS**

`portnum = 0`

**RETURN VALUE**

None

```
void rn_sp_disable(int portnum);
```

This is a macro that disables or deasserts the RCM3365/RCM3375 RabbitNet port chip select to invalidate data transfer.

**PARAMETERS**

`portnum = 0`

**RETURN VALUE**

None.

## 5.3 Upgrading Dynamic C

Dynamic C patches that focus on bug fixes are available from time to time. Check the Web site [www.rabbit.com/support/](http://www.rabbit.com/support/) for the latest patches, workarounds, and bug fixes.

### 5.3.1 Extras

Dynamic C installations are designed for use with the board they are included with, and are included at no charge as part of our low-cost kits.

Starting with Dynamic C version 9.60, Dynamic C includes the popular  $\mu$ C/OS-II real-time operating system, point-to-point protocol (PPP), FAT file system, RabbitWeb, and other select libraries. Rabbit also offers for purchase the Rabbit Embedded Security Pack featuring the Secure Sockets Layer (SSL) and a specific Advanced Encryption Standard (AES) library.

In addition to the Web-based technical support included at no extra charge, a one-year telephone-based technical support subscription is also available for purchase.

Visit our Web site at [www.rabbit.com](http://www.rabbit.com) for further information and complete documentation.

## 6. USING THE TCP/IP FEATURES

### 6.1 TCP/IP Connections

Programming and development can be done with the RCM3365/RCM3375 modules without connecting the Ethernet port to a network. However, if you will be running the sample programs that use the Ethernet capability or will be doing Ethernet-enabled development, you should connect the RCM3365/RCM3375 module's Ethernet port at this time.

Before proceeding you will need to have the following items.

- If you don't have Ethernet access, you will need at least a 10Base-T Ethernet card (available from your favorite computer supplier) installed in a PC.
- Two RJ-45 straight-through Ethernet cables and a hub, or an RJ-45 crossover Ethernet cable.

A straight-through and a crossover Ethernet cable are included in the RCM3365/RCM3375 Development Kit. Figure 11 shows how to identify the two cables based on the wires in the transparent RJ-45 connectors.

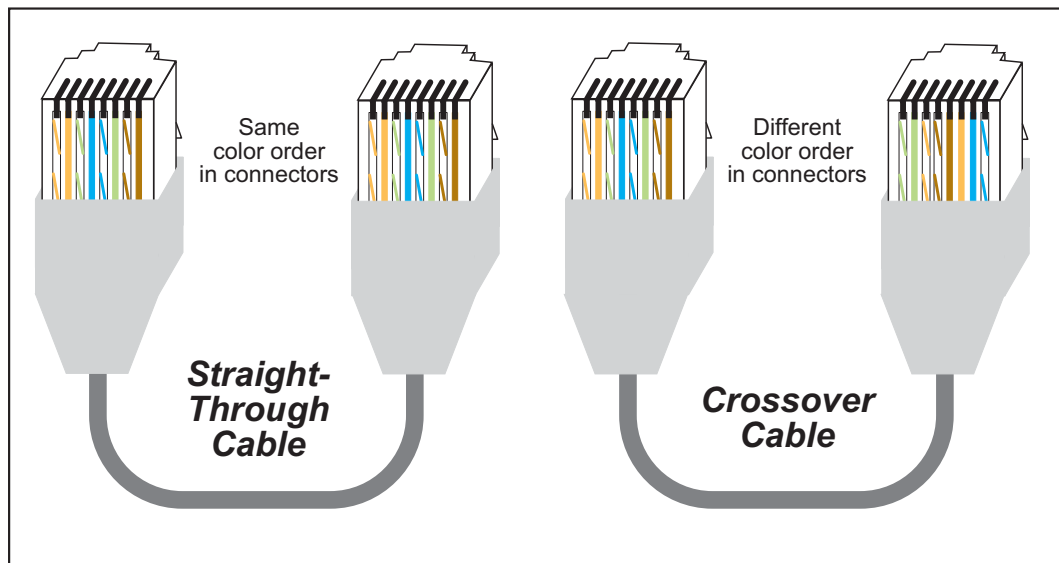

**Figure 11. How to Identify Straight-Through and Crossover Ethernet Cables**

Ethernet cables and a 10Base-T Ethernet hub are available from Rabbit in a TCP/IP tool kit. More information is available at [www.rabbit.com](http://www.rabbit.com).

Now you should be able to make your connections.

1. Connect the AC adapter and the serial programming cable as shown in Chapter 2, “Getting Started.”
2. Ethernet Connections

There are four options for connecting the RCM3365/RCM3375 module to a network for development and runtime purposes. The first two options permit total freedom of action in selecting network addresses and use of the “network,” as no action can interfere with other users. We recommend one of these options for initial development.

- **No LAN** — The simplest alternative for desktop development. Connect the RCM3365/RCM3375 module’s Ethernet port directly to the PC’s network interface card using an RJ-45 *crossover cable*. A crossover cable is a special cable that flips some connections between the two connectors and permits direct connection of two client systems. A standard RJ-45 network cable will not work for this purpose.
- **Micro-LAN** — Another simple alternative for desktop development. Use a small Ethernet 10Base-T hub and connect both the PC’s network interface card and the RCM3365/RCM3375 module’s Ethernet port to it using standard network cables.

The following options require more care in address selection and testing actions, as conflicts with other users, servers and systems can occur:

- **LAN** — Connect the RCM3365/RCM3375 module’s Ethernet port to an existing LAN, preferably one to which the development PC is already connected. You will need to obtain IP addressing information from your network administrator.
- **WAN** — The RCM3365/RCM3375 is capable of direct connection to the Internet and other Wide Area Networks, but exceptional care should be used with IP address settings and all network-related programming and development. We recommend that development and debugging be done on a local network before connecting a Rabbit-Core system to the Internet.

**TIP:** Checking and debugging the initial setup on a micro-LAN is recommended before connecting the system to a LAN or WAN.

The PC running Dynamic C does not need to be the PC with the Ethernet card.

3. Apply Power

Plug in the AC adapter. The RCM3365/RCM3375 module and Prototyping Board are now ready to be used.

## 6.2 TCP/IP Primer on IP Addresses

Obtaining IP addresses to interact over an existing, operating, network can involve a number of complications, and must usually be done with cooperation from your ISP and/or network systems administrator. For this reason, it is suggested that the user begin instead by using a direct connection between a PC and the RCM3365/RCM3375 using an Ethernet crossover cable or a simple arrangement with a hub. (A crossover cable should not be confused with regular straight through cables.)

In order to set up this direct connection, the user will have to use a PC without networking, or disconnect a PC from the corporate network, or install a second Ethernet adapter and set up a separate private network attached to the second Ethernet adapter. Disconnecting your PC from the corporate network may be easy or nearly impossible, depending on how it is set up. If your PC boots from the network or is dependent on the network for some or all of its disks, then it probably should not be disconnected. If a second Ethernet adapter is used, be aware that Windows TCP/IP will send messages to one adapter or the other, depending on the IP address and the binding order in Microsoft products. Thus you should have different ranges of IP addresses on your private network from those used on the corporate network. If both networks service the same IP address, then Windows may send a packet intended for your private network to the corporate network. A similar situation will take place if you use a dial-up line to send a packet to the Internet. Windows may try to send it via the local Ethernet network if it is also valid for that network.

The following IP addresses are set aside for local networks and are not allowed on the Internet: 10.0.0.0 to 10.255.255.255, 172.16.0.0 to 172.31.255.255, and 192.168.0.0 to 192.168.255.255.

The RCM3365/RCM3375 uses a 10/100Base-T type of Ethernet connection, which is the most common scheme. The RJ-45 connectors are similar to U.S. style telephone connectors, except they are larger and have 8 contacts.

An alternative to the direct connection using a crossover cable is a direct connection using a hub. The hub relays packets received on any port to all of the ports on the hub. Hubs are low in cost and are readily available. The RCM3365/RCM3375 uses 10/100 Mbps Ethernet, so the hub or Ethernet adapter can be a 10 Mbps unit, a 100 Mbps unit, or a 10/100 Mbps unit.

In a corporate setting where the Internet is brought in via a high-speed line, there are typically machines between the outside Internet and the internal network. These machines include a combination of proxy servers and firewalls that filter and multiplex Internet traffic. In the configuration below, the RCM3365/RCM3375 could be given a fixed address so any of the computers on the local network would be able to contact it. It may be possible to configure the firewall or proxy server to allow hosts on the Internet to directly contact the controller, but it would probably be easier to place the controller directly on the external network outside of the firewall. This avoids some of the configuration complications by sacrificing some security.

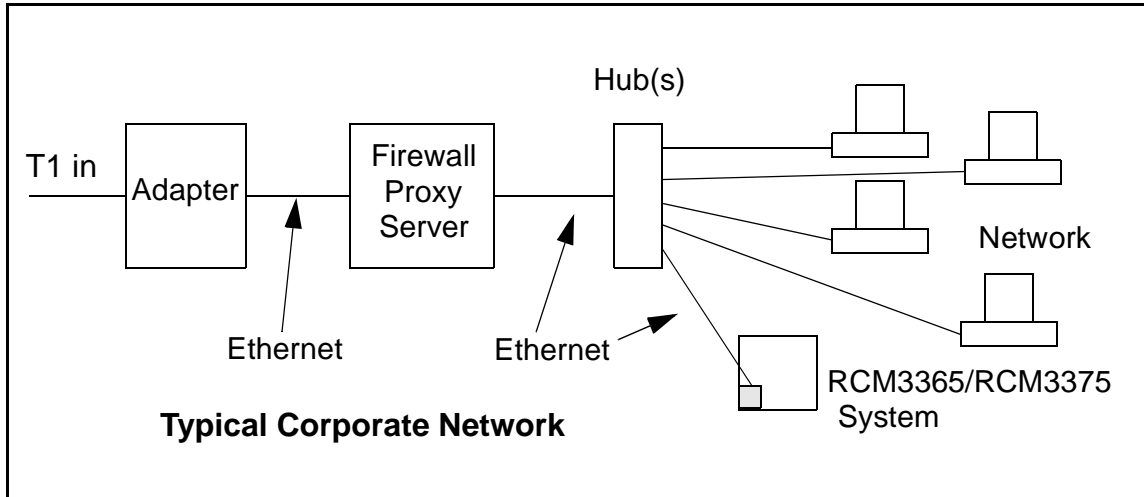

If your system administrator can give you an Ethernet cable along with its IP address, the netmask and the gateway address, then you may be able to run the sample programs without having to setup a direct connection between your computer and the RCM3365/RCM3375. You will also need the IP address of the nameserver, the name or IP address of your mail server, and your domain name for some of the sample programs.

## 6.2.1 IP Addresses Explained

IP (Internet Protocol) addresses are expressed as 4 decimal numbers separated by periods, for example:

216.103.126.155

10.1.1.6

Each decimal number must be between 0 and 255. The total IP address is a 32-bit number consisting of the 4 bytes expressed as shown above. A local network uses a group of adjacent IP addresses. There are always  $2^N$  IP addresses in a local network. The netmask (also called subnet mask) determines how many IP addresses belong to the local network. The netmask is also a 32-bit address expressed in the same form as the IP address. An example netmask is:

255.255.255.0

This netmask has 8 zero bits in the least significant portion, and this means that  $2^8$  addresses are a part of the local network. Applied to the IP address above (216.103.126.155), this netmask would indicate that the following IP addresses belong to the local network:

216.103.126.0

216.103.126.1

216.103.126.2

etc.

216.103.126.254

216.103.126.255

The lowest and highest address are reserved for special purposes. The lowest address (216.102.126.0) is used to identify the local network. The highest address (216.102.126.255) is used as a broadcast address. Usually one other address is used for the address of the gateway out of the network. This leaves  $256 - 3 = 253$  available IP addresses for the example given.

## 6.2.2 How IP Addresses are Used

The actual hardware connection via an Ethernet uses Ethernet adapter addresses (also called MAC addresses). These are 48-bit addresses and are unique for every Ethernet adapter manufactured. In order to send a packet to another computer, given the IP address of the other computer, it is first determined if the packet needs to be sent directly to the other computer or to the gateway. In either case, there is an Ethernet address on the local network to which the packet must be sent. A table is maintained to allow the protocol driver to determine the MAC address corresponding to a particular IP address. If the table is empty, the MAC address is determined by sending an Ethernet broadcast packet to all devices on the local network asking the device with the desired IP address to answer with its MAC address. In this way, the table entry can be filled in. If no device answers, then the device is nonexistent or inoperative, and the packet cannot be sent.

Some IP address ranges are reserved for use on internal networks, and can be allocated freely as long as no two internal hosts have the same IP address. These internal IP addresses are not routed to the Internet, and any internal hosts using one of these reserved IP addresses cannot communicate on the external Internet without being connected to a host that has a valid Internet IP address. The host would either translate the data, or it would act as a proxy.

Each RCM3365/RCM3375 RabbitCore module has its own unique MAC address, which consists of the prefix 0090C2 followed by a code that is unique to each RCM3365/RCM3375 module. For example, a MAC address might be 0090C2C002C0.

**TIP:** You can always obtain the MAC address on your board by running the sample program `DISPLAY_MAC.C` from the `SAMPLES\TCPIP` folder.



### 6.2.3 Dynamically Assigned Internet Addresses

In many instances, devices on a network do not have fixed IP addresses. This is the case when, for example, you are assigned an IP address dynamically by your dial-up Internet service provider (ISP) or when you have a device that provides your IP addresses using the Dynamic Host Configuration Protocol (DHCP). The RCM3365/RCM3375 modules can use such IP addresses to send and receive packets on the Internet, but you must take into account that this IP address may only be valid for the duration of the call or for a period of time, and could be a private IP address that is not directly accessible to others on the Internet. These addresses can be used to perform some Internet tasks such as sending e-mail or browsing the Web, but it is more difficult to participate in conversations that originate elsewhere on the Internet. If you want to find out this dynamically assigned IP address, under Windows 98 you can run the `winiipcfg` program while you are connected and look at the interface used to connect to the Internet.

Many networks use IP addresses that are assigned using DHCP. When your computer comes up, and periodically after that, it requests its networking information from a DHCP server. The DHCP server may try to give you the same address each time, but a fixed IP address is usually not guaranteed.

If you are not concerned about accessing the RCM3365/RCM3375 from the Internet, you can place the RCM3365/RCM3375 on the internal network using an IP address assigned either statically or through DHCP.

## 6.3 Placing Your Device on the Network

In many corporate settings, users are isolated from the Internet by a firewall and/or a proxy server. These devices attempt to secure the company from unauthorized network traffic, and usually work by disallowing traffic that did not originate from inside the network. If you want users on the Internet to communicate with your RCM3365/RCM3375, you have several options. You can either place the RCM3365/RCM3375 directly on the Internet with a real Internet address or place it behind the firewall. If you place the RCM3365/RCM3375 behind the firewall, you need to configure the firewall to translate and forward packets from the Internet to the RCM3365/RCM3375.

## 6.4 Running TCP/IP Sample Programs

We have provided a number of sample programs demonstrating various uses of TCP/IP for networking embedded systems. These programs require you to connect your PC and the RCM3365/RCM3375 board together on the same network. This network can be a local private network (preferred for initial experimentation and debugging), or a connection via the Internet.

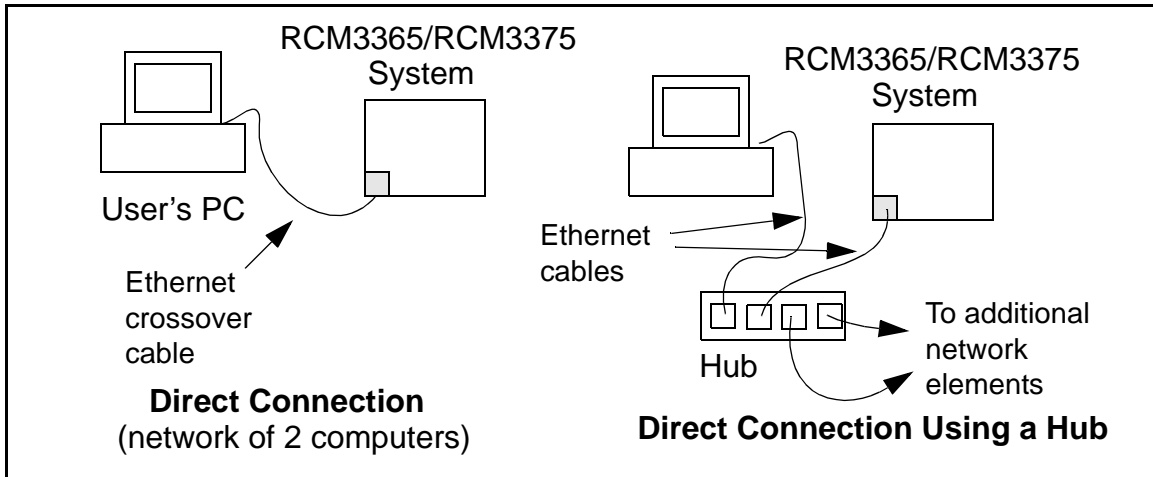

The sample programs described in this chapter may also be run with a RabbitSys-enabled RCM3365 operating in the RabbitSys mode. There is no change to the instructions when you use the serial programming cable. When you use an Ethernet cable, you may use CAT 5/6 straight-through Ethernet cables to connect the RCM3365 and your PC to a DHCP network. It is not necessary to use a crossover cable for a direct connection. Use the TCP/IP parameters such as the IP address that you identified with the `rdiscover` utility; if you are using an Ethernet crossover cable to connect the RCM3365 directly to your PC, use the TCP/IP parameters that you set up according to the instructions in Appendix E.

## 6.4.1 How to Set IP Addresses in the Sample Programs

With the introduction of Dynamic C 7.30 we have taken steps to make it easier to run many of our sample programs. You will see a **TCPCONFIG** macro. This macro tells Dynamic C to select your configuration from a list of default configurations. You will have three choices when you encounter a sample program with the **TCPCONFIG** macro.

1. You can replace the **TCPCONFIG** macro with individual **MY\_IP\_ADDRESS**, **MY\_NETMASK**, **MY\_GATEWAY**, and **MY\_NAMESERVER** macros in each program.
2. You can leave **TCPCONFIG** at the usual default of 1, which will set the IP configurations to **10.10.6.100**, the netmask to **255.255.255.0**, and the nameserver and gateway to **10.10.6.1**. If you would like to change the default values, for example, to use an IP address of **10.1.1.2** for the RCM3365/RCM3375 board, and **10.1.1.1** for your PC, you can edit the values in the section that directly follows the “General Configuration” comment in the **TCP\_CONFIG.LIB** library. You will find this library in the **LIB\TCPIP** directory.
3. You can create a **CUSTOM\_CONFIG.LIB** library and use a **TCPCONFIG** value greater than 100. Instructions for doing this are at the beginning of the **TCP\_CONFIG.LIB** library in the **LIB\TCPIP** directory.

There are some other “standard” configurations for **TCPCONFIG** that let you select different features such as DHCP. Their values are documented at the top of the **TCP\_CONFIG.LIB** library in the **LIB\TCPIP** directory. More information is available in the *Dynamic C TCP/IP User’s Manual*.

## 6.4.2 How to Set Up your Computer for Direct Connect

Follow these instructions to set up your PC or notebook. Check with your administrator if you are unable to change the settings as described here since you may need administrator privileges. The instructions are specifically for Windows 2000, but the interface is similar for other versions of Windows.

**TIP:** If you are using a PC that is already on a network, you will disconnect the PC from that network to run these sample programs. Write down the existing settings before changing them to facilitate restoring them when you are finished with the sample programs and reconnect your PC to the network.

1. Go to the control panel (**Start > Settings > Control Panel**), and then double-click the Network icon.
2. Select the network interface card used for the Ethernet interface you intend to use (e.g., **TCP/IP Xircom Credit Card Network Adapter**) and click on the “Properties” button. Depending on which version of Windows your PC is running, you may have to select the “Local Area Connection” first, and then click on the “Properties” button to bring up the Ethernet interface dialog. Then “Configure” your interface card for a “10Base-T Half-Duplex” or an “Auto-Negotiation” connection on the “Advanced” tab.

**NOTE:** Your network interface card will likely have a different name.

3. Now select the **IP Address** tab, and check **Specify an IP Address**, or select TCP/IP and click on “Properties” to assign an IP address to your computer (this will disable “obtain an IP address automatically”):

IP Address : 10.10.6.101  
Netmask : 255.255.255.0  
Default gateway : 10.10.6.1

4. Click **<OK>** or **<Close>** to exit the various dialog boxes.

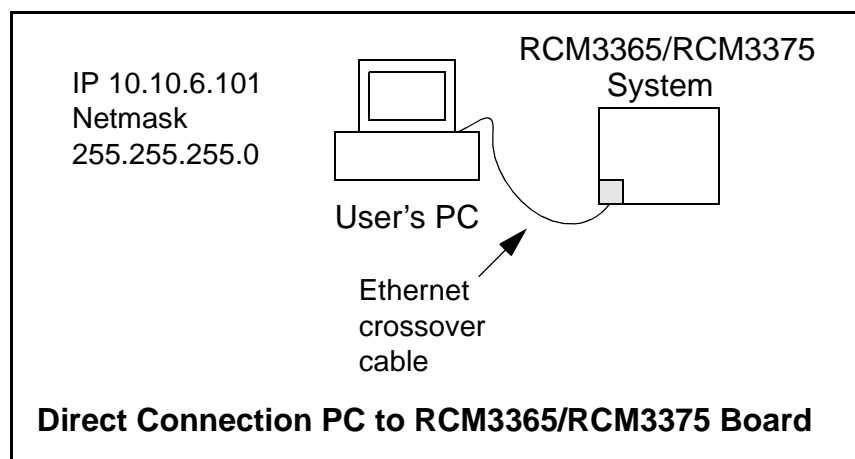

## 6.5 Run the `PINGME.C` Sample Program

Connect the crossover cable from your computer's Ethernet port to the RCM3365/RCM3375 board's RJ-45 Ethernet connector. Open this sample program from the `SAMPLES\TCPIP\ICMP` folder, compile the program, and start it running under Dynamic C. The crossover cable is connected from your computer's Ethernet adapter to the RCM3365/RCM3375 board's RJ-45 Ethernet connector. When the program starts running, the green **LINK** light on the RCM3365/RCM3375 module should be on to indicate an Ethernet connection is made. (Note: If the **LNK** light does not light, you may not be using a crossover cable, or if you are using a hub with straight-through cables perhaps the power is off on the hub.)

The next step is to ping the board from your PC. This can be done by bringing up the MS-DOS window and running the pingme program:

```
ping 10.10.6.101
```

or by **Start > Run**

and typing the entry

```
ping 10.10.6.101
```

Notice that the yellow **ACT** light flashes on the RCM3365/RCM3375 module while the ping is taking place, and indicates the transfer of data. The ping routine will ping the board four times and write a summary message on the screen describing the operation.

## 6.6 Running Additional Sample Programs With Direct Connect

The following sample programs are in the Dynamic C `SAMPLES\RCM3360\TCPIP\` folder.

- **BROWSELED.C**—This program demonstrates a basic controller running a Web page. Two “device LEDs” are created along with two buttons to toggle them. Users can use their Web browser to change the status of the lights. The DS3 and DS4 LEDs on the Prototyping Board will match those on the Web page. As long as you have not modified the `TCPCONFIG 1` macro in the sample program, enter the following server address in your Web browser to bring up the Web page served by the sample program.

```
http://10.10.6.100.
```

Otherwise use the TCP/IP settings you entered in the `TCP_CONFIG.LIB` library.

- **MBOXDEMO.C**—The optional LCD/keypad module (see Appendix C) must be plugged in to the Prototyping Board when using this sample program. This program demonstrates sending e-mail messages that are then shown on the LCD/keypad module display. The keypad is used to scroll through a menu to view the messages, flip to other messages, mark messages as read, and delete messages. When a new e-mail arrives, an LED on the LCD/keypad module turns on, and then turns off once the message has been marked as read. A log of all e-mail actions is kept, and can be displayed in the Web browser. All current e-mails can also be read with the Web browser.

- **PINGLED.C**—This program demonstrates ICMP by pinging a remote host. It will flash LEDs DS3 and DS4 on the Prototyping Board when a ping is sent and received.
- **SMTP.C**—This program demonstrates using the SMTP library to send an e-mail when the S2 and S3 switches on the Prototyping Board are pressed. LEDs DS3 and DS4 on the Prototyping Board will light up when e-mail is being sent.

### 6.6.1 RabbitWeb Sample Programs

You will need to have the Dynamic C RabbitWeb module installed before you run the sample programs described in this section. The following sample programs are in the Dynamic C `SAMPLES\RCM3360\TCP\IP\RABBITWEB` folder.

- **BLINKLEDS.C**—This program demonstrates a basic example to change the rate at which the DS3 and DS4 LEDs on the Prototyping Board blink.
- **DOORMONITOR.C**—The optional LCD/keypad module (see Appendix C) must be plugged in to the Prototyping Board when using this sample program. This program demonstrates adding and monitoring passwords entered via the LCD/keypad module.
- **SPRINKLER.C**—This program demonstrates how to schedule times for the relay and digital outputs in a 24-hour period.

## 6.7 Where Do I Go From Here?

**NOTE:** If you purchased your RCM3365/RCM3375 through a distributor or through a Rabbit partner, contact the distributor or partner first for technical support.

If there are any problems at this point:

- Use the Dynamic C **Help** menu to get further assistance with Dynamic C.
- Check the Rabbit Technical Bulletin Board and forums at [www.rabbit.com/support/bb/](http://www.rabbit.com/support/bb/) and at [www.rabbit.com/forums/](http://www.rabbit.com/forums/).
- Use the Technical Support e-mail form at [www.rabbit.com/support/](http://www.rabbit.com/support/).

If the sample programs ran fine, you are now ready to go on.

Additional sample programs are described in the *Dynamic C TCP/IP User's Manual*.

Please refer to the *Dynamic C TCP/IP User's Manual* to develop your own applications. *An Introduction to TCP/IP* provides background information on TCP/IP, and is available on the CD and on our [Web site](#).







## **APPENDIX A. RCM3365/RCM3375 SPECIFICATIONS**

Appendix A provides the specifications for the RCM3365/  
RCM3375, and describes the conformal coating.

## A.1 Electrical and Mechanical Characteristics

Figure A-1 shows the mechanical dimensions for the RCM3365/RCM3375.

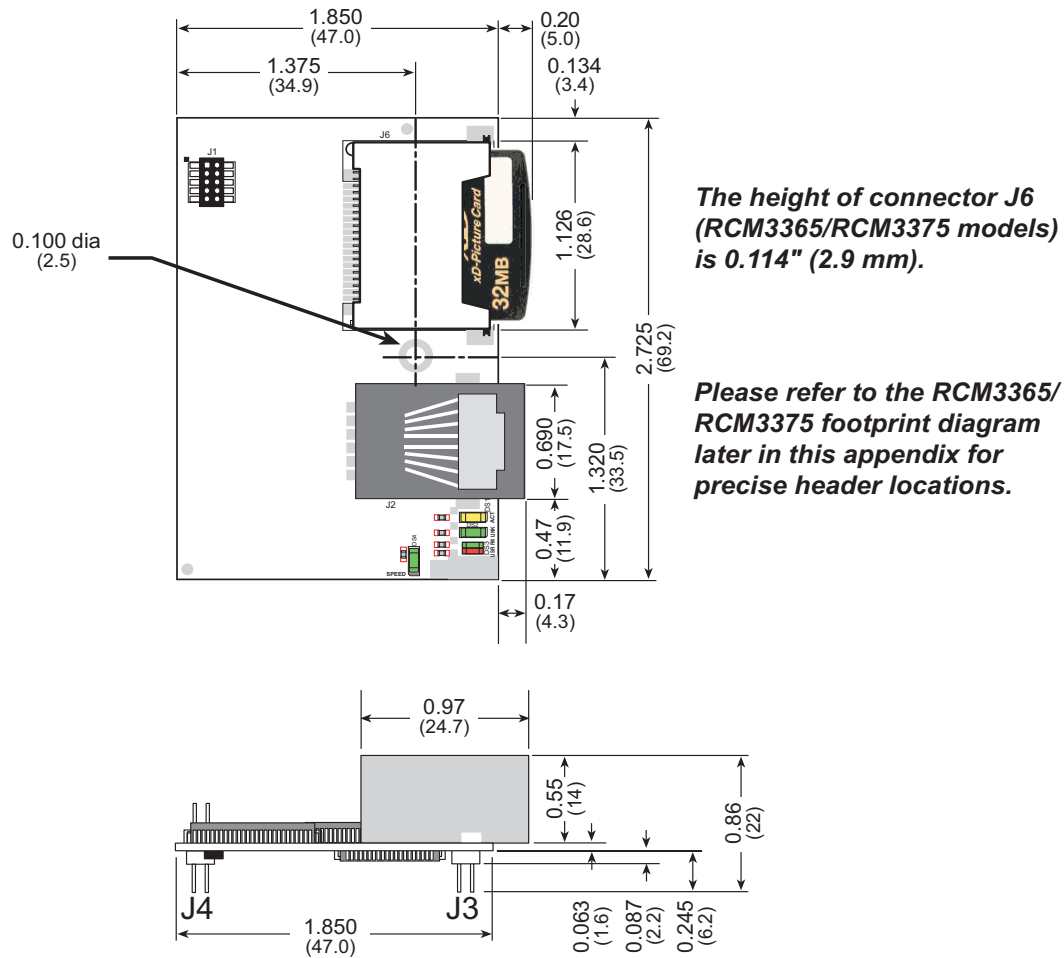

**Figure A-1. RCM3365/RCM3375 Dimensions**

**NOTE:** All measurements are in inches followed by millimeters enclosed in parentheses. All dimensions have a manufacturing tolerance of  $\pm 0.01$ " (0.25 mm).

It is recommended that you allow for an “exclusion zone” of 0.04" (1 mm) around the RCM3365/RCM3375 in all directions when the RCM3365/RCM3375 is incorporated into an assembly that includes other printed circuit boards. An “exclusion zone” of 0.08" (2 mm) is recommended below the RCM3365/RCM3375 when the RCM3365/RCM3375 is plugged into another assembly. Figure A-2 shows this “exclusion zone.”

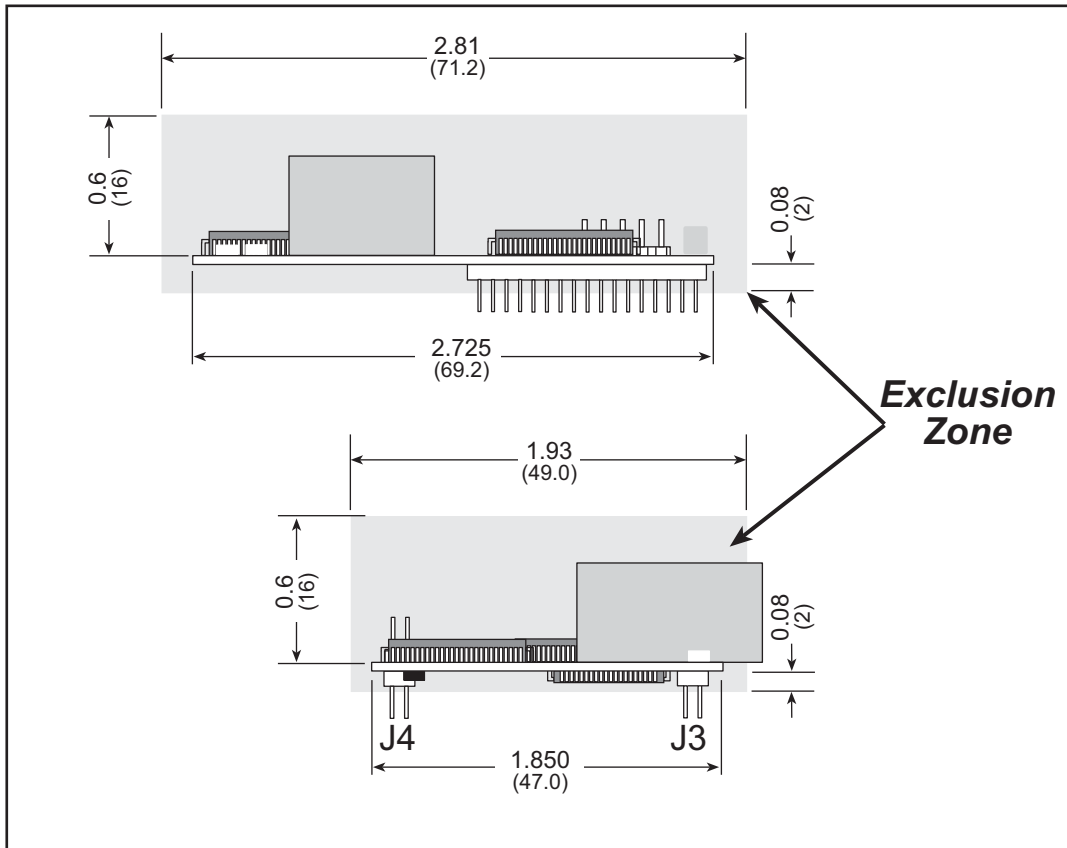

**Figure A-2. RCM3365/RCM3375 “Exclusion Zone”**

**NOTE:** All measurements are in inches followed by millimeters enclosed in parentheses.

Table A-1 lists the electrical, mechanical, and environmental specifications for the RCM3365/RCM3375.

**Table A-1. RabbitCore RCM3365/RCM3375 Specifications**

Parameter	RCM3365	RCM3375
Microprocessor	Low-EMI Rabbit® 3000 at 44.2 MHz	
EMI Reduction	Spectrum spreader for reduced EMI (radiated emissions)	
Ethernet Port	10/100Base-T, RJ-45, 3 LEDs	
SRAM	512K program (fast SRAM) + 512K data	
Flash Memory (program)	512K	
Flash Memory (mass data storage)	32MB (fixed)* +xD-Picture Card with up to 128MB (NAND flash)	xD-Picture Card with up to 128MB (NAND flash)
LED Indicators	ACT (activity) LINK (link) SPEED (on for 100Base-T Ethernet connection) FM (flash memory, NAND) USR (user-programmable)	
Backup Battery	Connection for user-supplied backup battery (to support RTC and data SRAM)	
General-Purpose I/O	52 parallel digital I/O lines: <ul style="list-style-type: none"> <li>• 44 configurable I/O</li> <li>• 4 fixed inputs</li> <li>• 4 fixed outputs</li> </ul>	
Additional Inputs	Startup mode (2), reset in	
Additional Outputs	Status, reset out	
External I/O Bus	Can be configured for 8 data lines and 5 address lines (shared with parallel I/O lines), plus I/O read/write	
Serial Ports	Six 3.3 V, CMOS-compatible ports (shared with I/O) <ul style="list-style-type: none"> <li>• all 6 configurable as asynchronous (with IrDA)</li> <li>• 4 configurable as clocked serial (SPI)</li> <li>• 2 configurable as SDLC/HDLC</li> <li>• 1 asynchronous serial port dedicated for programming</li> </ul>	
Serial Rate	Maximum asynchronous baud rate = CLK/8	
Slave Interface	A slave port allows the RCM3365/RCM3375 to be used as an intelligent peripheral device slaved to a master processor, which may either be another Rabbit 3000 or any other type of processor	
Real-Time Clock	Yes	
Timers	Ten 8-bit timers (6 cascadable, 3 reserved for internal peripherals), one 10-bit timer with 2 match registers	

**Table A-1. RabbitCore RCM3365/RCM3375 Specifications (continued)**

Parameter	RCM3365	RCM3375
Watchdog/Supervisor	Yes	
Pulse-Width Modulators	4 PWM registers with 10-bit free-running counter and priority interrupts	
Input Capture	2-channel input capture can be used to time input signals from various port pins	
Quadrature Decoder	2-channel quadrature decoder accepts inputs from external incremental encoder modules	
Power	3.15–3.45 V DC 250 mA @ 44.2 MHz, 3.3 V	
Operating Temperature	-40°C to +70°C (boards manufactured up to May, 2008) 0°C to +70°C (boards manufactured after May, 2008)	
Humidity	5% to 95%, noncondensing	
Connectors	Two 2 × 17, 2 mm pitch one 2 × 5 for programming with 1.27 mm pitch one xD-Picture Card slot (RCM3365/RCM3375)	
Board Size	1.850" × 2.725" × 0.86" (47 mm × 69 mm × 22 mm)	

\* RCM3365 modules sold before 2008 had 16MB fixed NAND flash memory.

**NOTE:** M-type *xD-Picture Cards* are *not* supported at this time.

## A.1.1 Headers

The RCM3365/RCM3375 uses headers at J3 and J4 for physical connection to other boards. J3 and J4 are  $2 \times 17$  SMT headers with a 2 mm pin spacing. J1, the programming port, is a  $2 \times 5$  header with a 1.27 mm pin spacing.

Figure A-3 shows the layout of another board for the RCM3365/RCM3375 to be plugged into. These reference design values are relative to the mounting hole.

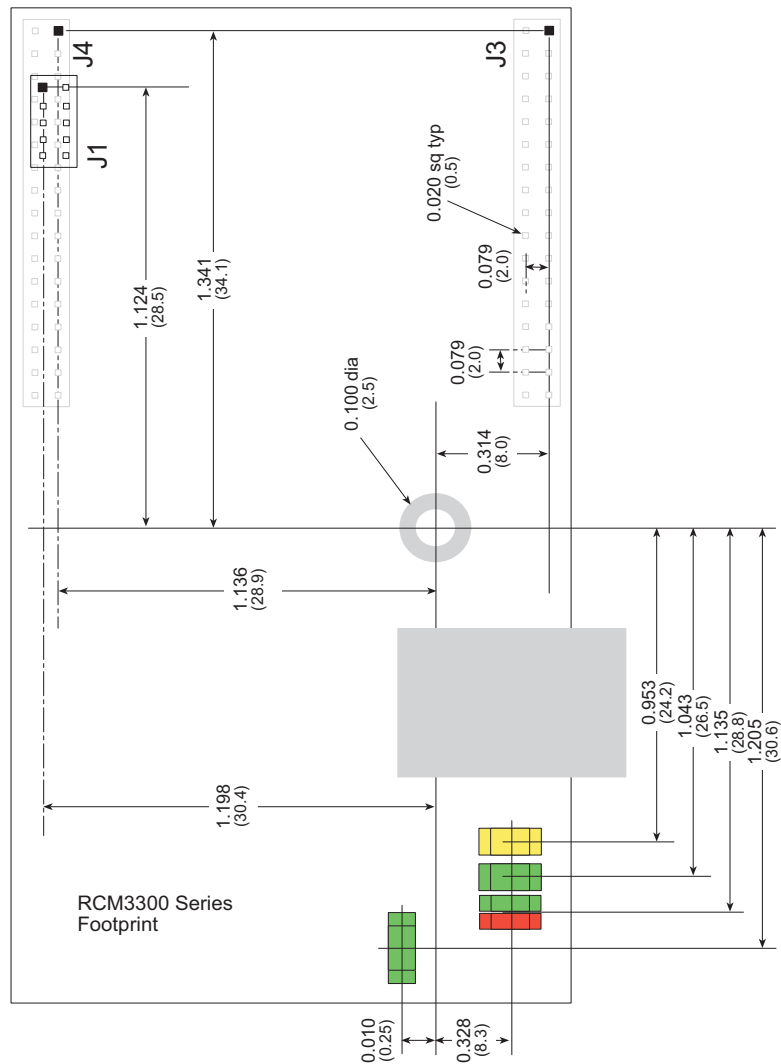

**Figure A-3. User Board Footprint for RCM3365/RCM3375**

## A.2 Bus Loading

You must pay careful attention to bus loading when designing an interface to the RCM3365/RCM3375. This section provides bus loading information for external devices.

Table A-2 lists the capacitance for the various RCM3365/RCM3375 I/O ports.

**Table A-2. Capacitance of Rabbit 3000 I/O Ports**

I/O Ports	Input Capacitance (pF)	Output Capacitance (pF)
Parallel Ports A to G	12	14

Table A-3 lists the external capacitive bus loading for the various RCM3365/RCM3375 output ports. Be sure to add the loads for the devices you are using in your custom system and verify that they do not exceed the values in Table A-3.

**Table A-3. External Capacitive Bus Loading -40°C to +85°C**

Output Port	Clock Speed (MHz)	Maximum External Capacitive Loading (pF)
All I/O lines with clock doubler enabled	44.2	100

Figure A-4 shows a typical timing diagram for the Rabbit 3000 microprocessor external I/O read and write cycles.

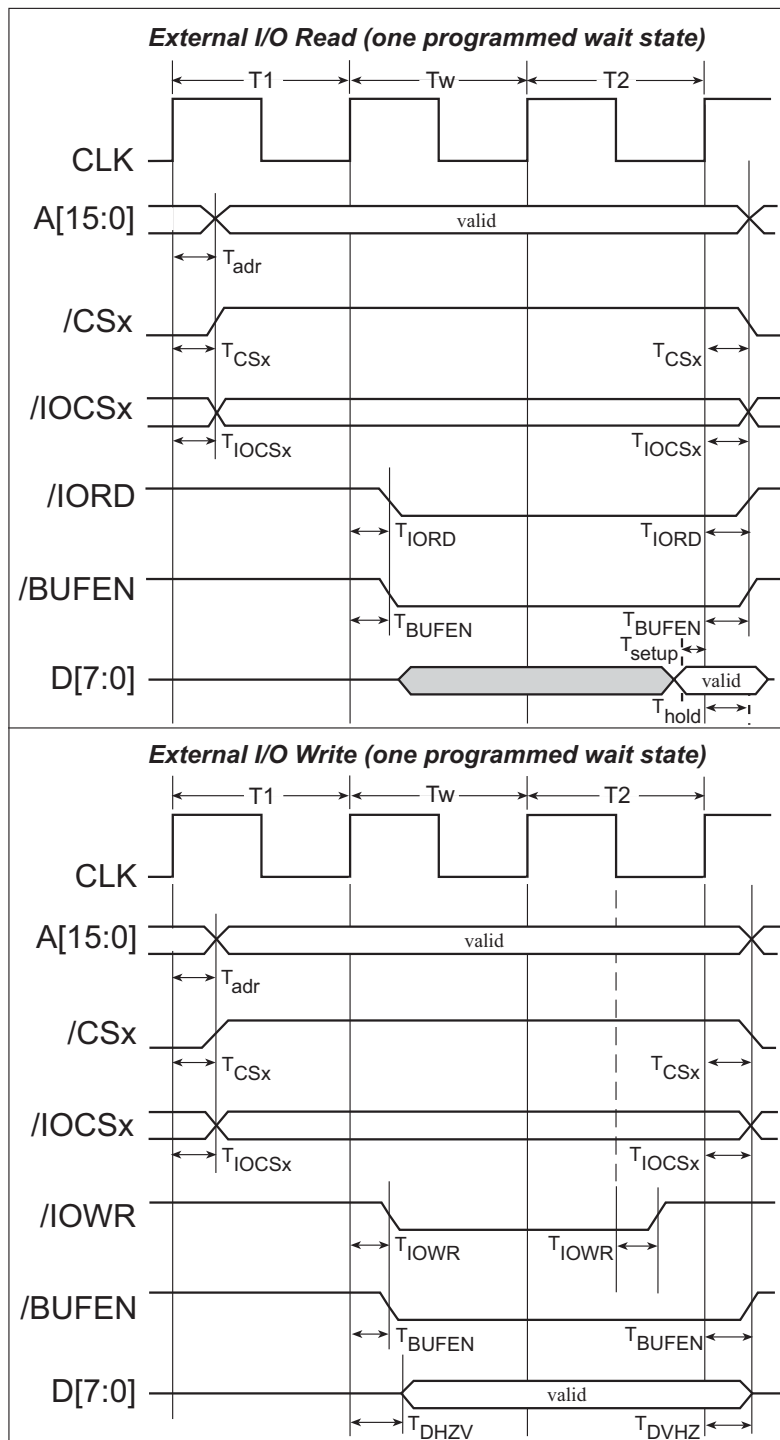

Figure A-4. I/O Read and Write Cycles—No Extra Wait States

NOTE: /IOCSx can be programmed to be active low (default) or active high.



Table A-4 lists the delays in gross memory access time at 3.3 V.

**Table A-4. Data and Clock Delays  $V_{IN} \pm 10\%$ , Temp,  $-40^{\circ}\text{C}$ – $+85^{\circ}\text{C}$  (maximum)**

VIN	Clock to Address Output Delay (ns)			Data Setup Time Delay (ns)	Spectrum Spreader Delay (ns)	
	30 pF	60 pF	90 pF		Normal no dbl/dbl	Strong no dbl/dbl
3.3 V	6	8	11	1	3/4.5	4.5/9

The measurements are taken at the 50% points under the following conditions.

- $T = -40^{\circ}\text{C}$  to  $85^{\circ}\text{C}$ ,  $V = V_{DD} \pm 10\%$
- Internal clock to nonloaded CLK pin delay  $\leq 1$  ns @  $85^{\circ}\text{C}/3.0$  V

The clock to address output delays are similar, and apply to the following delays.

- $T_{adr}$ , the clock to address delay
- $T_{CSx}$ , the clock to memory chip select delay
- $T_{IOCSx}$ , the clock to I/O chip select delay
- $T_{IORD}$ , the clock to I/O read strobe delay
- $T_{IOWR}$ , the clock to I/O write strobe delay
- $T_{BUFEN}$ , the clock to I/O buffer enable delay

The data setup time delays are similar for both  $T_{setup}$  and  $T_{hold}$ .

When both the spectrum spreader and the clock doubler are enabled, every other clock cycle is shortened (sometimes lengthened) by a maximum amount given in the table above. The shortening takes place by shortening the high part of the clock. If the doubler is not enabled, then every clock is shortened during the low part of the clock period. The maximum shortening for a pair of clocks combined is shown in the table.

Technical Note TN227, *Interfacing External I/O with Rabbit 2000/3000 Designs*, contains suggestions for interfacing I/O devices to the Rabbit 3000 microprocessors.

## A.3 Rabbit 3000 DC Characteristics

**Table A-5. Rabbit 3000 Absolute Maximum Ratings**

Symbol	Parameter	Maximum Rating
$T_A$	Operating Temperature	-55° to +85°C
$T_S$	Storage Temperature	-65° to +150°C
	Maximum Input Voltage: <ul style="list-style-type: none"> <li>• Oscillator Buffer Input</li> <li>• 5-V-tolerant I/O</li> </ul>	$V_{DD} + 0.5\text{ V}$ 5.5 V
$V_{DD}$	Maximum Operating Voltage	3.6 V

Stresses beyond those listed in Table A-5 may cause permanent damage. The ratings are stress ratings only, and functional operation of the Rabbit 3000 chip at these or any other conditions beyond those indicated in this section is not implied. Exposure to the absolute maximum rating conditions for extended periods may affect the reliability of the Rabbit 3000 chip.

Table A-6 outlines the DC characteristics for the Rabbit 3000 at 3.3 V over the recommended operating temperature range from  $T_A = -55^\circ\text{C}$  to  $+85^\circ\text{C}$ ,  $V_{DD} = 3.0\text{ V}$  to  $3.6\text{ V}$ .

**Table A-6. 3.3 Volt DC Characteristics**

Symbol	Parameter	Test Conditions	Min	Typ	Max	Units
$V_{DD}$	Supply Voltage		3.0	3.3	3.6	V
$V_{IH}$	High-Level Input Voltage		2.0			V
$V_{IL}$	Low-Level Input Voltage				0.8	V
$V_{OH}$	High-Level Output Voltage	$I_{OH} = 6.8\text{ mA}$ , $V_{DD} = V_{DD}(\text{min})$	0.7 x $V_{DD}$			V
$V_{OL}$	Low-Level Output Voltage	$I_{OL} = 6.8\text{ mA}$ , $V_{DD} = V_{DD}(\text{min})$			0.4	V
$I_{IH}$	High-Level Input Current (absolute worst case, all buffers)	$V_{IN} = V_{DD}$ , $V_{DD} = V_{DD}(\text{max})$			10	$\mu\text{A}$
$I_{IL}$	Low-Level Input Current (absolute worst case, all buffers)	$V_{IN} = V_{SS}$ , $V_{DD} = V_{DD}(\text{max})$	-10			$\mu\text{A}$
$I_{OZ}$	High-Impedance State Output Current (absolute worst case, all buffers)	$V_{IN} = V_{DD}$ or $V_{SS}$ , $V_{DD} = V_{DD}(\text{max})$ , no pull-up	-10		10	$\mu\text{A}$

## A.4 I/O Buffer Sourcing and Sinking Limit

Unless otherwise specified, the Rabbit I/O buffers are capable of sourcing and sinking 6.8 mA of current per pin at full AC switching speed. Full AC switching assumes a 22.1 MHz CPU clock and capacitive loading on address and data lines of less than 100 pF per pin. The absolute maximum operating voltage on all I/O is 5.5 V.

Table A-7 shows the AC and DC output drive limits of the parallel I/O buffers when the Rabbit 3000 is used in the RCM3365/RCM3375.

**Table A-7. I/O Buffer Sourcing and Sinking Capability**

Pin Name	Output Drive (Full AC Switching) Sourcing/Sinking Limits (mA)	
	Sourcing	Sinking
All data, address, and I/O lines with clock doubler enabled	6.8	6.8

Under certain conditions, you can exceed the limits outlined in Table A-7. See the *Rabbit 3000 Microprocessor User's Manual* for additional information.

## A.5 Jumper Configurations

Figure A-5 shows the jumper locations used to configure the various RCM3365/RCM3375 options. The black square indicates pin 1.

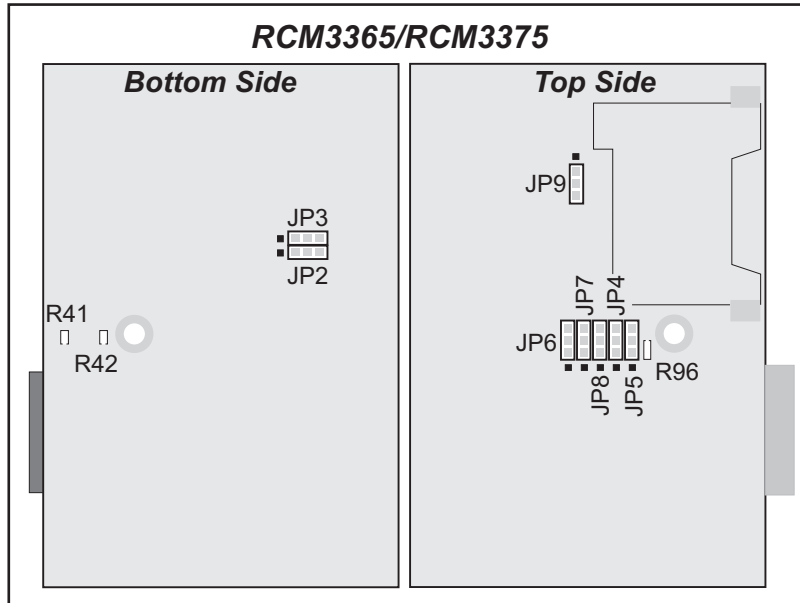

**Figure A-5. Location of RCM3365/RCM3375 Configurable Positions**

Table A-8 lists the configuration options.

**Table A-8. RCM3365/RCM3375 Jumper Configurations**

Header	Description	Pins Connected		Factory Default
JP2	Flash Memory Bank Select	1-2	Bank Mode	
		2-3	Normal Mode	×
JP3	Data SRAM Size	1-2	128K/256K	
		2-3	512K	×
JP4	Ethernet or I/O Output on Header J3	1-2	TPO+	
		2-3	PD3	×
JP5	Ethernet or I/O Output on Header J3	1-2	TPO-	
		2-3	PD2	×
JP6	Ethernet or I/O Output on Header J3	1-2	ENET_INT	
		2-3	PE0	×
JP7	Ethernet or I/O Output on Header J3	1-2	TPI+	
		2-3	PD7	×
JP8	Ethernet or I/O Output on Header J3	1-2	TPI-	
		2-3	PD6	×
JP9	Chip select signals for NAND flash and <i>xD-Picture Card</i>	1-2	Separate chip select signals to NAND flash and <i>xD-Picture Card</i>	
		2-3	Separate chip select signals for NAND flash and <i>xD-Picture Card</i>	×
R96	<i>xD-Picture Card</i> Detect	installed	<i>xD-Picture Card</i> Detect available	×
		not installed	PB0 may be used as CLKB (synchronous Serial Port B)	

**NOTE:** The jumper connections are made using 0  $\Omega$  surface-mounted resistors.

## A.6 Conformal Coating

The areas around the 32 kHz real-time clock crystal oscillator have had the Dow Corning silicone-based 1-2620 conformal coating applied. The conformally coated area is shown in Figure A-6. The conformal coating protects these high-impedance circuits from the effects of moisture and contaminants over time.

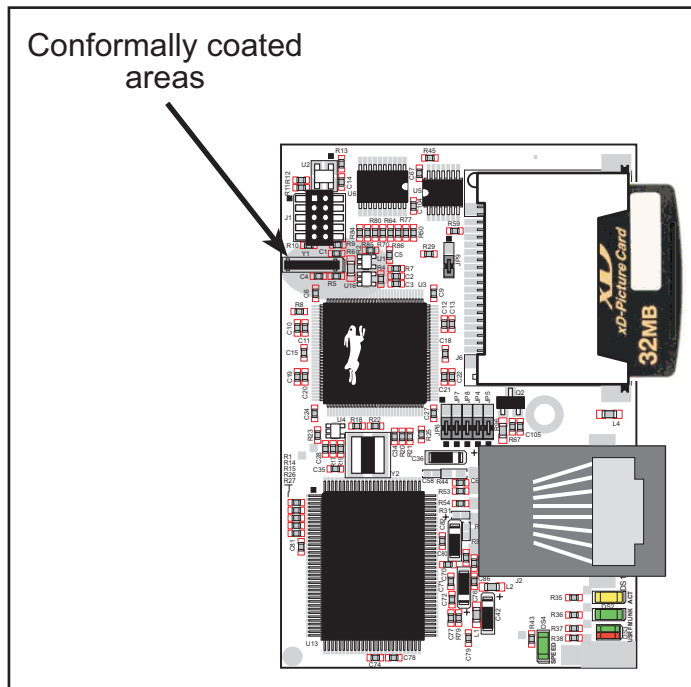

**Figure A-6. RCM3365/RCM3375 Areas Receiving Conformal Coating**

Any components in the conformally coated area may be replaced using standard soldering procedures for surface-mounted components. A new conformal coating should then be applied to offer continuing protection against the effects of moisture and contaminants.

**NOTE:** For more information on conformal coatings, refer to Technical Note 303, *Conformal Coatings*.



## **APPENDIX B. PROTOTYPING BOARD**

Appendix B describes the features and accessories of the Prototyping Board.

## B.1 Introduction

The Prototyping Board included in the Development Kit makes it easy to connect an RCM3365/RCM3375 module to a power supply and a PC workstation for development. It also provides some basic I/O peripherals (RS-232, RS-485, a relay, LEDs, and switches), as well as a prototyping area for more advanced hardware development.

For the most basic level of evaluation and development, the Prototyping Board can be used without modification.

As you progress to more sophisticated experimentation and hardware development, modifications and additions can be made to the board without modifying or damaging the RCM3365/RCM3375 module itself.

The Prototyping Board is shown below in Figure B-1, with its main features identified.

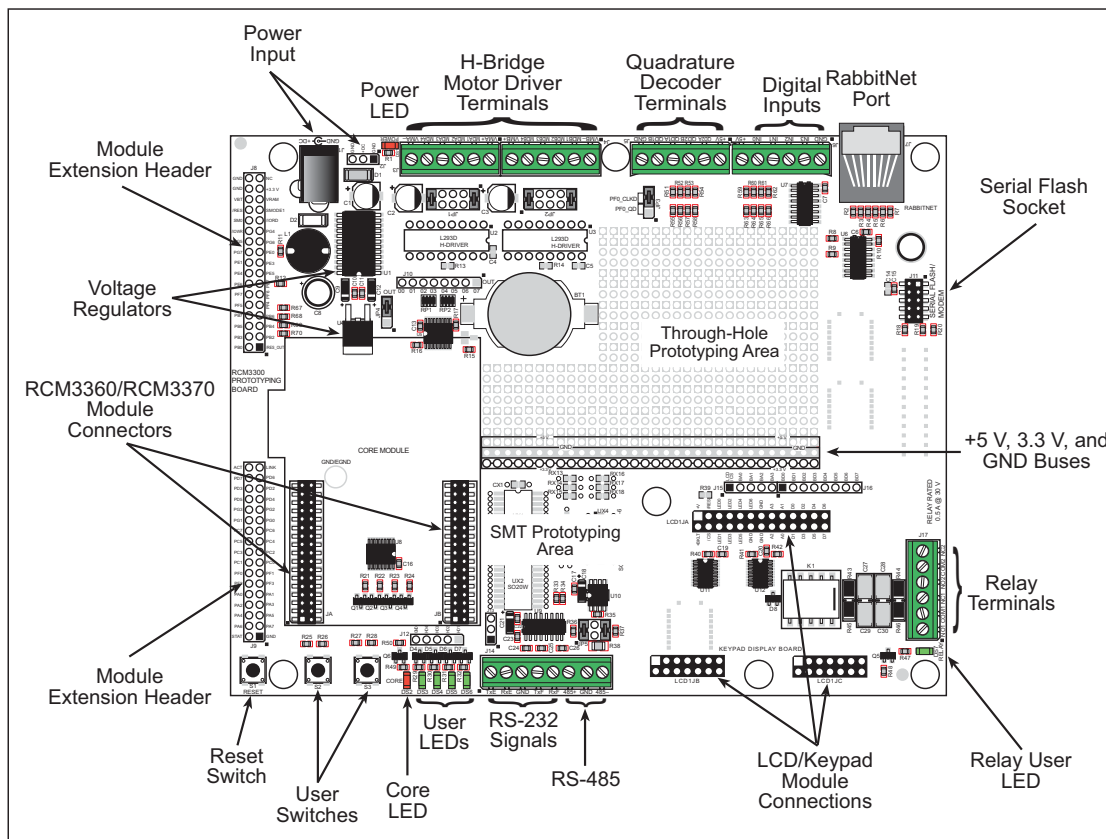

**Figure B-1. Prototyping Board**



## B.1.1 Prototyping Board Features

- **Power Connection**—A power-supply jack and a 3-pin header are provided for connection to the power supply. Note that the 3-pin header is symmetrical, with both outer pins connected to ground and the center pin connected to the raw V+ input. The cable of the AC adapter provided with the North American version of the Development Kit ends in a plug that connects to the power-supply jack (J1). A header plug leading to bare leads is provided for overseas customers to connect their power supply to the 3-pin header (J2)—the center pin of J2 is always connected to the positive terminal, and either edge pin is negative.

Users providing their own power supply should ensure that it delivers 8–30 V DC at 1 A.

- **Regulated Power Supply**—The raw DC voltage provided at the POWER IN jack is routed to a 5 V switching voltage regulator, then to a separate 3.3 V linear regulator. The regulators provide stable power to the RCM3365/RCM3375 module and the Prototyping Board. The voltage regulators will get warm while in use.
- **Power LED**—The power LED lights whenever power is connected to the Prototyping Board.
- **Core LED**—The core LED lights whenever an RCM3365/RCM3375 module is plugged in correctly on the Prototyping Board and the RCM3365/RCM3375 module is not being reset.
- **Relay LED**—The relay LED lights whenever the Prototyping Board relay is energized.
- **Reset Switch**—A momentary-contact, normally open switch is connected directly to the RCM3365/RCM3375's /RESET\_IN pin. Pressing the switch forces a hardware reset of the system.
- **I/O Switches and LEDs**—Two momentary-contact, normally open switches are connected to the PG0 and PG1 pins of the RCM3365/RCM3375 module and may be read as inputs by sample applications.

Four user LEDs (DS3–DS6) are connected to alternate I/O bus pins PA0–PA3 pins of the RCM3365/RCM3375 module via U8, and may be driven as output indicators. PE7 and PG5 control the registers in U8 as shown in the sample applications.

- **Prototyping Area**—A generous prototyping area has been provided for the installation of through-hole components. +3.3 V, +5 V, and Ground buses run along one edge of this area. Several areas for surface-mount devices are also available. Each SMT pad is connected to a hole designed to accept a 30 AWG solid wire.
- **LCD/Keypad Module**—Rabbit's LCD/keypad module may be plugged in directly to headers LCD1JA, LCD1JB, and LCD1JC. The signals on headers LCD1JB and LCD1JC will be available only if the LCD/keypad module is plugged in to header LCD1JA. Appendix C provides complete information for mounting and using the LCD/keypad module.

- **Module Extension Headers**—The complete pin set of the RCM3365/RCM3375 module is duplicated at headers J8 and J9. Developers can solder wires directly into the appropriate holes, or, for more flexible development,  $2 \times 17$  header strips with a 0.1" pitch can be soldered into place. See Figure B-4 for the header pinouts.
- **Digital I/O**—Four digital inputs are available on screw-terminal header J6. See Figure B-4 for the header pinouts.
- **RS-232**—Two 3-wire serial ports or one 5-wire RS-232 serial port are available on the Prototyping Board at screw-terminal header J14.
- **RS-485**—One RS-485 serial port is available on the Prototyping Board at screw-terminal header J14.
- **Quadrature Decoder**—Four quadrature decoder inputs (PF0–PF3) from the Rabbit 3000 chip are available on screw-terminal header J5. See Figure B-4 for the header pinouts.
- **H-Bridge Motor Driver**—Two pairs of H-bridge motor drivers are supported using screw-terminal headers J3 and J4 on the Prototyping Board for stepper-motor control. See Figure B-4 for the header pinouts.
- **RabbitNet Port**—One RS-422 RabbitNet port (shared with the serial flash interface) is available to allow RabbitNet peripheral cards to be used with the RCM3365/RCM3375 and the Prototyping Board.
- **Serial Flash Interface**—One serial flash interface (shared with the RabbitNet port) is available to allow Rabbit’s SF1000 series serial flash to be used on the Prototyping Board.

## B.2 Mechanical Dimensions and Layout

Figure B-2 shows the mechanical dimensions and layout for the Prototyping Board.

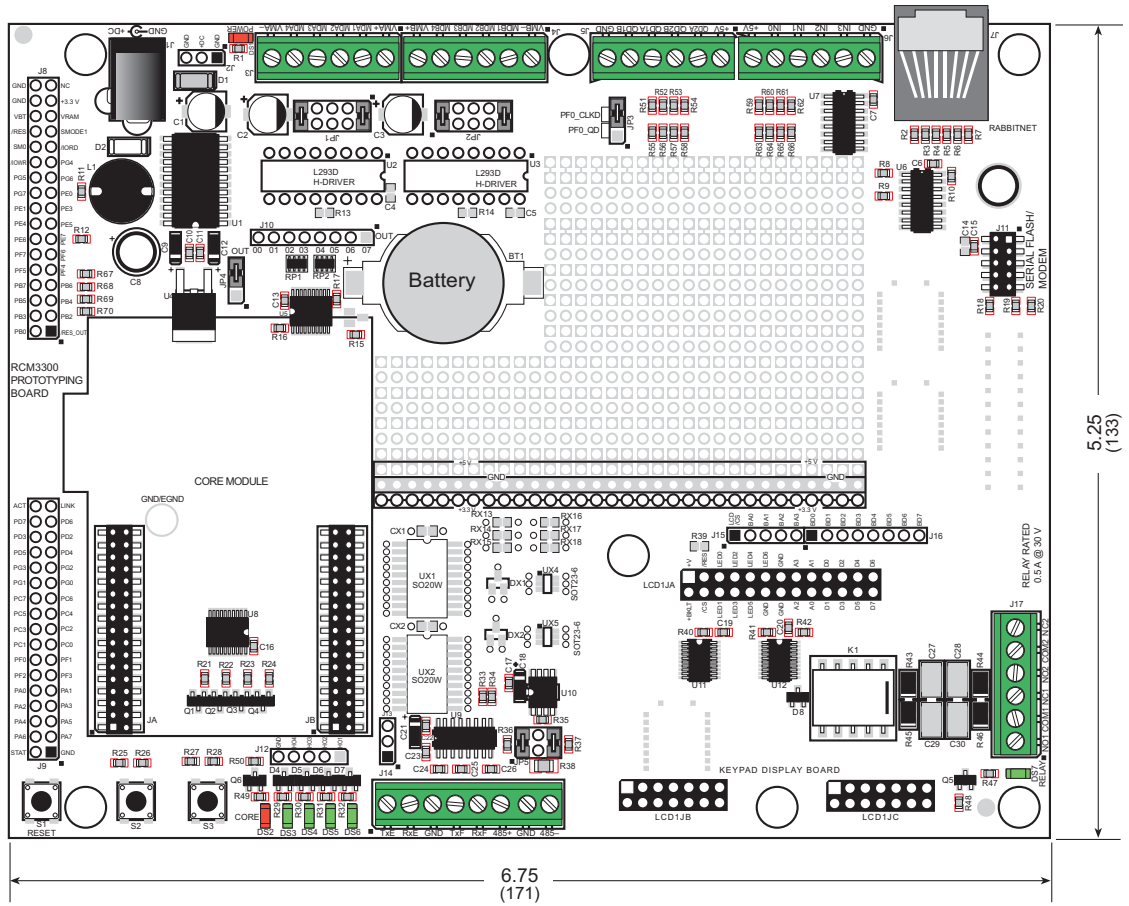

**Figure B-2. Prototyping Board Dimensions**

**NOTE:** All measurements are in inches followed by millimeters enclosed in parentheses.

Table B-1 lists the electrical, mechanical, and environmental specifications for the Prototyping Board.

**Table B-1. Prototyping Board Specifications**

Parameter	Specification
Board Size	5.25" × 6.75" × 1.00" (133 mm × 171 mm × 25 mm)
Operating Temperature	−20°C to +70°C
Humidity	5% to 95%, noncondensing
Input Voltage	8 V to 30 V DC
Maximum Current Draw (including user-added circuits)	800 mA max. for +3.3 V supply, 1 A total +3.3 V and +5 V combined
Backup Battery	CR2032, 3 V lithium coin-type
Digital Inputs	4 inputs pulled up, ± 36 V DC, switching threshold 0.9–2.3 V typical
Digital Outputs	4 sinking outputs,+30 V DC, 500 mA maximum per channel 8 CMOS-level outputs if stepper motor not installed
Relay	SPDT relay, 500 mA @ 30 V
Serial Ports	<ul style="list-style-type: none"> <li>• two 3-wire RS-232 <i>or</i> one RS-232 with RTS/CTS</li> <li>• one RS-485</li> </ul>
Other Serial Interfaces	RabbitNet RS-422 port <i>or</i> serial flash interface
Other Interfaces	<ul style="list-style-type: none"> <li>• stepper motor control</li> <li>• quadrature decoder</li> <li>• LCD/keypad module</li> </ul>
LEDs	Seven LEDs <ul style="list-style-type: none"> <li>• one power on indicator</li> <li>• one RCM3365/RCM3375 module indicator</li> <li>• four user-configurable LEDs</li> <li>• one relay indicator</li> </ul>
Prototyping Area	Throughhole, 0.1" spacing, additional space for SMT components
Connectors	<ul style="list-style-type: none"> <li>• two 2 × 17, 2 mm pitch sockets for RCM3365/RCM3375 module</li> <li>• one 2 × 5, 2 mm pitch socket for serial flash</li> <li>• six screw-terminal headers for serial ports, digital inputs, stepper motor control, quadrature decoder, and relay contacts</li> <li>• one RJ-45 RabbitNet jack</li> </ul>
Standoffs/Spacers	7, accept 4-40 x 1/2 screws

## B.3 Power Supply

The RCM3365/RCM3375 requires a regulated 3.15 V to 3.45 V DC power source to operate. Depending on the amount of current required by the application, different regulators can be used to supply this voltage.

The Prototyping Board has an onboard +5 V switching power regulator from which a +3.3 V linear regulator draws its supply. Thus both +5 V and +3.3 V are available on the Prototyping Board.

The Prototyping Board itself is protected against reverse polarity by a diode at D1 as shown in Figure B-3.

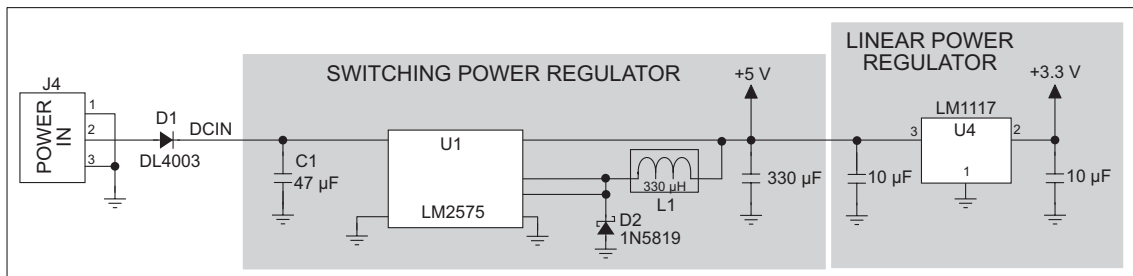

**Figure B-3. Prototyping Board Power Supply**

## B.4 Using the Prototyping Board

The Prototyping Board is actually both a demonstration board and a prototyping board. As a demonstration board, it can be used with the sample programs to demonstrate the functionality of the RCM3365/RCM3375 right out of the box without any modifications.

The Prototyping Board pinouts are shown in Figure B-4.

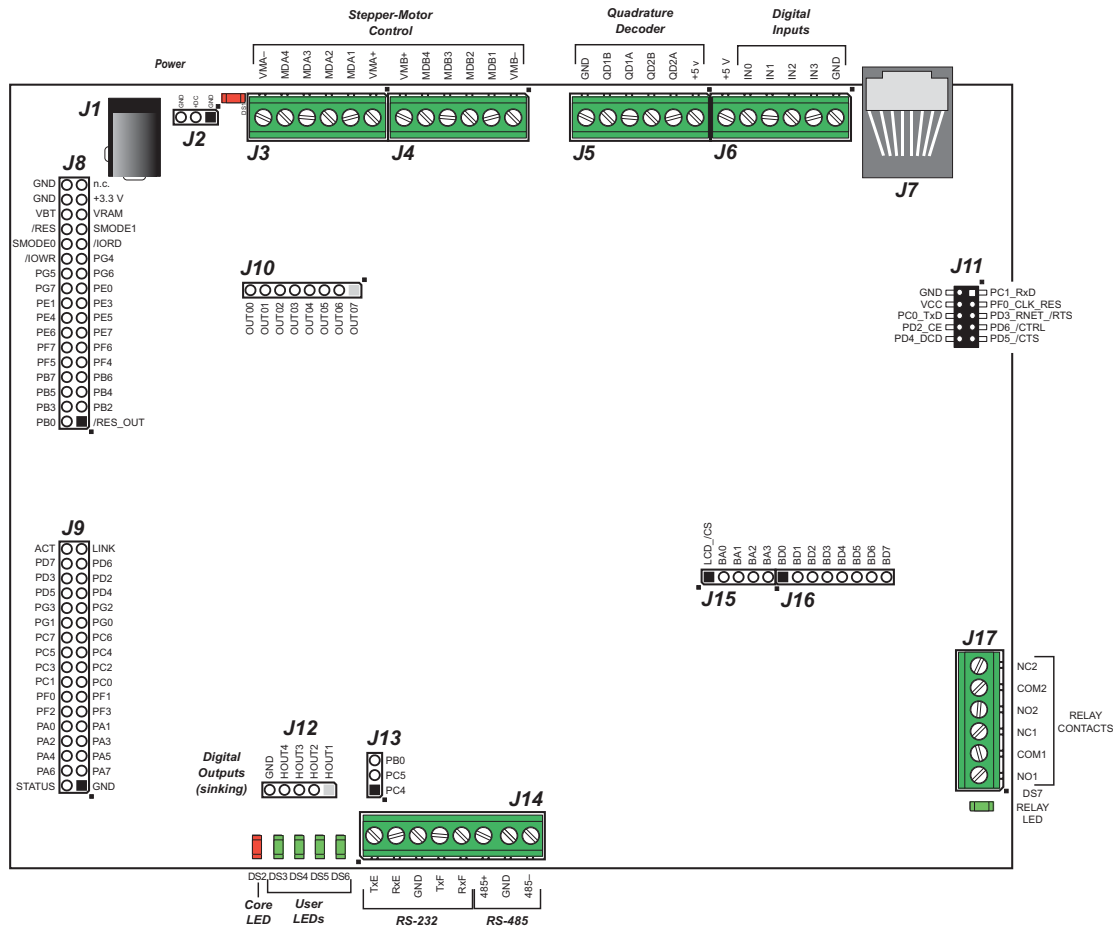

Figure B-4. Prototyping Board Pinout

The Prototyping Board comes with the basic components necessary to demonstrate the operation of the RCM3365/RCM3375. Four user LEDs (DS3–DS6) are connected to alternate I/O bus pins PA0–PA3 pins of the RCM3365/RCM3375 module via U8, and may be driven as output indicators when controlled by PE7 and PG5 as shown in the sample applications. Two switches (S2 and S3) are connected to PG0 and PG1 to demonstrate the interface to the Rabbit 3000 microprocessor. Reset switch S1 is the hardware reset for the RCM3365/RCM3375.

The Prototyping Board provides the user with RCM3365/RCM3375 connection points brought out conveniently to labeled points at J8 and J9 on the Prototyping Board. Although locations J8 and J9 are unstuffed,  $2 \times 17$  headers are included in the bag of parts.

RS-232 and RS-485 signals are available on screw-terminal header J14, quadrature decoder inputs are available on screw-terminal header J5, and digital inputs are available on screw-terminal header J6. A  $1 \times 5$  header strip from the bag of parts may be installed at J12 for four sinking digital outputs. A  $1 \times 3$  header strip from the bag of parts may be installed at J13 to access selected signals from RCM3000, RCM3100, RCM3200, RCM3300/RCM3310, and RCM3365/RCM3375 RabbitCore modules (J13 cannot be used with the RCM3305/RCM3315).

If you don't plan to use the LCD/keypad module, additional signals may be brought out on  $1 \times 5$  and  $1 \times 8$  headers from the bag of parts that you install at J15 and J16. If you don't plan to use the stepper-motor control option, additional CMOS outputs are available via a  $1 \times 8$  header that you install at J10.

There is a through-hole prototyping space available on the Prototyping Board. The holes in the prototyping area are spaced at 0.1" (2.5 mm). +3.3 V, +5 V, and GND traces run along one edge of the prototyping area. Small to medium circuits can be prototyped using point-to-point wiring with 20 to 30 AWG wire between the prototyping area, the +3.3 V, +5 V, and GND traces, and the surrounding area where surface-mount components may be installed. Small holes are provided around the surface-mounted components that may be installed around the prototyping area.

#### **B.4.1 Adding Other Components**

There are two sets of pads for 6-pin, 16-pin, and 28-pin devices that can be used for surface-mount prototyping devices. There are also pads that can be used for SMT resistors and capacitors in an 0805 SMT package. Each component has every one of its pin pads connected to a hole in which a 30 AWG wire can be soldered (standard wire wrap wire can be soldered in for point-to-point wiring on the Prototyping Board). Because the traces are very thin, carefully determine which set of holes is connected to which surface-mount pad.

## B.4.2 Digital I/O

### B.4.2.1 Digital Inputs

The Prototyping Board has four digital inputs, IN0–IN3, each of which is protected over a range of  $-36\text{ V}$  to  $+36\text{ V}$ . The inputs are pulled up to  $+3.3\text{ V}$  as shown in Figure B-5.

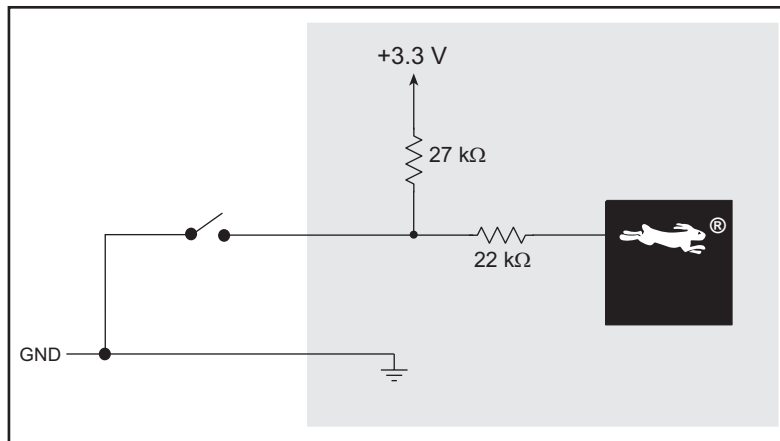

**Figure B-5. Prototyping Board Digital Inputs**

The four quadrature decoder inputs on screw-terminal header J5 may be used as inputs IN4–IN7. To use the PF0 signal from the Rabbit microprocessor, which goes to QD1B, remember to reconfigure the jumper on header JP3 to jumper pins 1–2.

The actual switching threshold is between  $0.9\text{ V}$  and  $2.3\text{ V}$ . Anything below this value is a logic 0, and anything above is a logic 1.

The digital inputs are each fully protected over a range of  $-36\text{ V}$  to  $+36\text{ V}$ , and can handle short spikes of  $\pm 40\text{ V}$ .



### B.4.3 CMOS Digital Outputs

If the stepper-motor option is not used, eight CMOS-level digital outputs are available at J10, and can each handle up to 25 mA.

### B.4.4 Sinking Digital Outputs

Four sinking digital outputs shared with LEDs DS3–DS6 are available at J12, and can each handle up to 500 mA. Figure B-6 shows a wiring diagram for a typical sinking output.

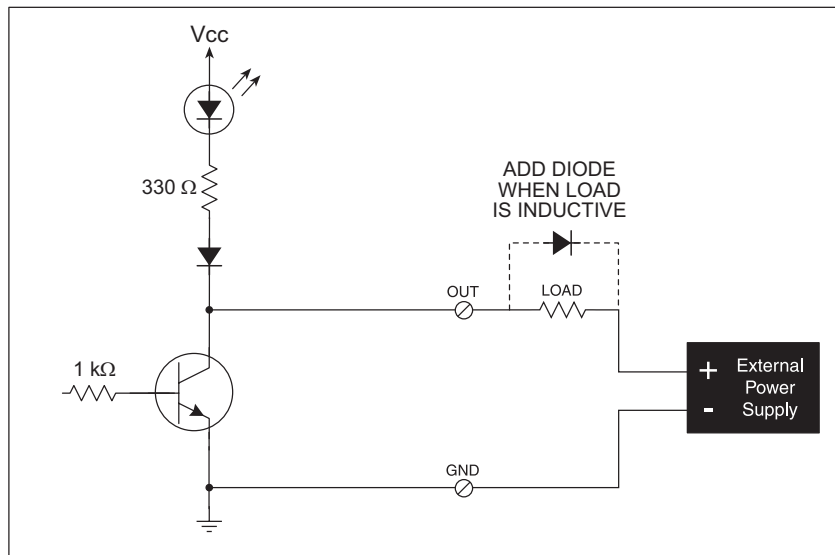

**Figure B-6. Prototyping Board Sinking Digital Outputs**

### B.4.5 Relay Outputs

Figure B-7 shows the contact connections for the relay on the Prototyping Board. A diode across the coil provides a return path for inductive spikes, and snubbers across the relay contacts protect the relay contacts from inductive spikes.

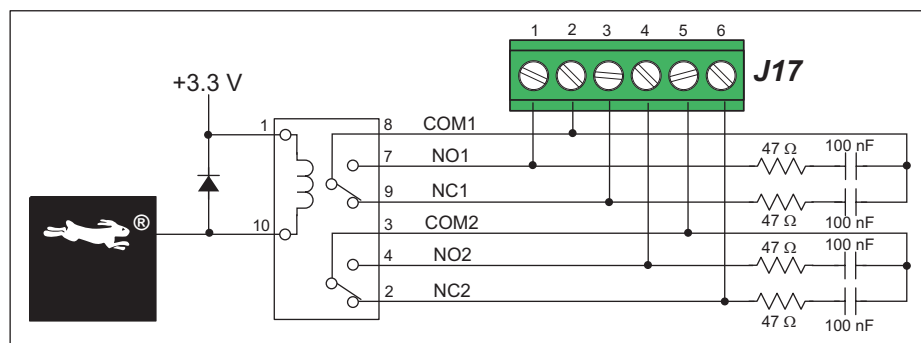

**Figure B-7. Prototyping Board Relay Output Contact Connections**

The relay is driven by pin PA4 of the RCM3365/RCM3375 module via U8, and is controlled by PE7 and PG5 as shown in the sample applications.

## B.4.6 Serial Communication

The Prototyping Board allows you to access up to five of the serial ports from the RCM3365/RCM3375 module. Table B-2 summarizes the configuration options.

**Table B-2. Prototyping Board Serial Port Configurations**

Serial Port	Signal Header	Configured via	Default Use	Alternate Use
B	J9	—	RCM3365/RCM3375 Serial Port B signals on PB0, PC4 and PC5	—
C	J14	JP5*	RS-485	—
D	J7	JP3	RabbitNet (PD2 = 1)	Rabbit 3000 quadrature decoder
	J11		SF1000 (PD2 = 0)	
E	J14	—	RS-232	—
F	J14	—	RS-232	—

\* RS-485 termination and bias resistors are configured via header JP5.

Serial Port D is configured in software either to allow J7 to be used as a RabbitNet port or to allow J11 to be used as a serial interface for the SF1000 series serial flash.

### B.4.6.1 RS-232

RS-232 serial communication on the Prototyping Board is supported by an RS-232 transceiver installed at U9. This transceiver provides the voltage output, slew rate, and input voltage immunity required to meet the RS-232 serial communication protocol. Basically, the chip translates the Rabbit 3000's signals to RS-232 signal levels. Note that the polarity is reversed in an RS-232 circuit so that a +5 V output becomes approximately -10 V and 0 V is output as +10 V. The RS-232 transceiver also provides the proper line loading for reliable communication.

RS-232 can be used effectively at the RCM3365/RCM3375 module's maximum baud rate for distances of up to 15 m.

RS-232 flow control on an RS-232 port is initiated in software using the `serXflowcontrolOn` function call from `RS232.LIB`, where `X` is the serial port (E or F). The locations of the flow control lines are specified using a set of five macros.

`SERX_RTS_PORT`—Data register for the parallel port that the RTS line is on (e.g., PGDR).

`SERX_RTS_SHADOW`—Shadow register for the RTS line's parallel port (e.g., PGDRShadow).

`SERX_RTS_BIT`—The bit number for the RTS line.

`SERX_CTS_PORT`—Data register for the parallel port that the CTS line is on (e.g., PCDRShadow).

`SERX_CTS_BIT`—The bit number for the CTS line.

Standard 3-wire RS-232 communication using Serial Ports E and F is illustrated in the following sample code.

```
#define EINBUFSIZE 15 // set size of circular buffers in bytes
#define EOUTBUFSIZE 15
#define FINBUFSIZE 15
#define FOUTBUFSIZE 15
#define MYBAUD 115200 // set baud rate
#endif
main(){
    serEopen(_MYBAUD); // open Serial Ports E and F
    serFopen(_MYBAUD);
    serEwrFlush(); // flush their input and transmit buffers
    serErdfFlush();
    serFwrFlush();
    serFrdFlush();
    serEclose(_MYBAUD); // close Serial Ports C and D
    serFclose(_MYBAUD);
}
```

### B.4.6.2 RS-485

The Prototyping Board has one RS-485 serial channel, which is connected to the Rabbit 3000 Serial Port C through an RS-485 transceiver. The half-duplex communication uses an output from PD7 on the Rabbit 3000 to control the transmit enable on the communication line. Using this scheme a strict master/slave relationship must exist between devices to insure that no two devices attempt to drive the bus simultaneously.

Serial Port C is configured in software for RS-485 as follows.

```
#define ser485open serCopen
#define ser485close serCclose
#define ser485wrFlush serCwrFlush
#define ser485rdFlush serCrdFlush
#define ser485putc serCputc
#define ser485getc serCgetc

#define CINBUFSIZE 15
#define COUTBUFSIZE 15

#ifndef _485BAUD
#define _485BAUD 115200
#endif
#endif
```

The configuration shown above is based on circular buffers. RS-485 configuration may also be done using functions from the `PACKET.LIB` library.

The Prototyping Boards with RCM3365/RCM3375 modules installed can be used in an RS-485 multidrop network spanning up to 1200 m (4000 ft), and there can be as many as 32 attached devices. Connect the 485+ to 485+ and 485- to 485- using single twisted-pair wires as shown in Figure B-8. Note that a common ground is recommended.

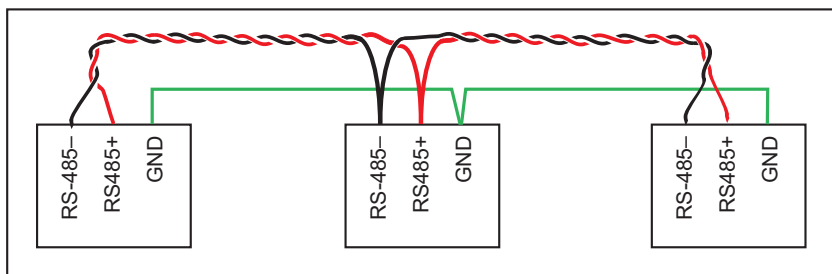

**Figure B-8. Multidrop Network**

The Prototyping Board comes with a 220  $\Omega$  termination resistor and two 681  $\Omega$  bias resistors installed and enabled with jumpers across pins 1–2 and 5–6 on header JP5, as shown in Figure B-9.

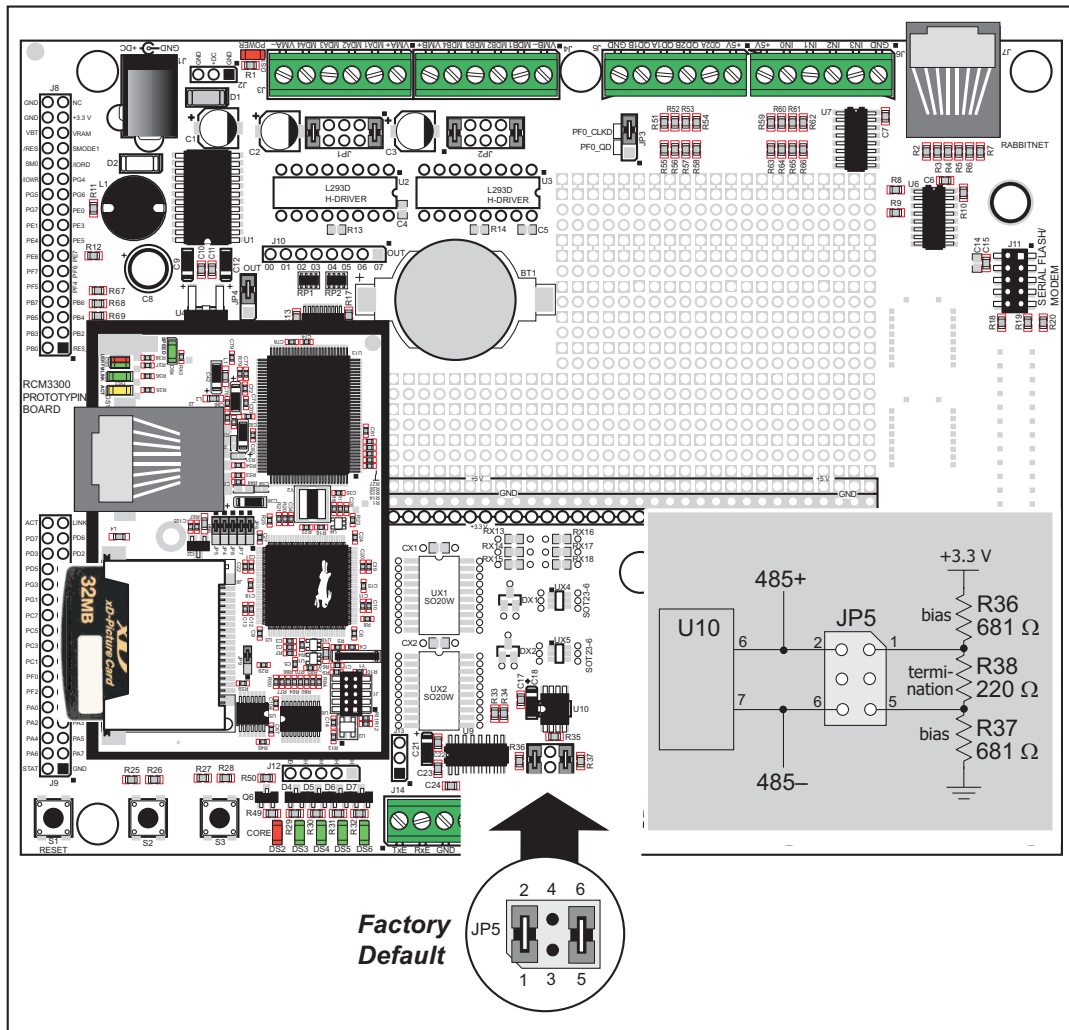

**Figure B-9. RS-485 Termination and Bias Resistors**

For best performance, the termination resistors in a multidrop network should be enabled only on the end nodes of the network, but *not* on the intervening nodes. Jumpers on boards whose termination resistors are not enabled may be stored across pins 1–3 and 4–6 of header JP5.

#### B.4.7 RabbitNet Ports

The RJ-45 jack labeled *RabbitNet* is a clocked SPI RS-422 serial I/O expansion port for use with RabbitNet peripheral boards. The *RabbitNet* jack does *not* support Ethernet connections. Header JP3 must have pins 2–3 jumpered when using the RabbitNet port.

The RabbitNet port is enabled in software by setting PD2 = 1. Note that the RabbitNet port and the J11 interface cannot be used simultaneously.

## B.4.8 Other Prototyping Board Modules

An optional LCD/keypad module is available that can be mounted on the Prototyping Board. The signals on headers LCD1JB and LCD1JC will be available only if the LCD/keypad module is installed. Refer to Appendix C, “LCD/Keypad Module,” for complete information.

Rabbit’s SF1000 series serial flash may be installed in the socket labeled J11. The J11 interface is enabled in software by setting PD2 = 0. Header JP3 must have pins 2–3 jumpered when using the J11 interface. Note that the RabbitNet port and the J11 interface cannot be used simultaneously.

## B.4.9 Quadrature Decoder

Four quadrature decoder inputs are available on screw-terminal header J5. To use the PF0 input from the Rabbit microprocessor, which goes to the QD1B input, remember to reconfigure the jumper on header JP3 to jumper pins 1–2.

Additional information on the use of the quadrature Decoders on Parallel Port F is provided in the *Rabbit 3000 Microprocessor User’s Manual*.

## B.4.10 Stepper-Motor Control

The Prototyping Board can be used to demonstrate the use of the RCM3365/RCM3375 to control a stepper motor. Stepper motor control typically directs moves in two orthogonal directions, and so two sets of stepper-motor control circuits are provided for via screw-terminal headers J3 and J4.

In order to use the stepper-motor control, install two Texas Instruments L293DN chips at locations U2 and U3 (shown in Figure B-10). These chips are readily available from your favorite electronics parts source, and may be purchased through our [Web store](#) as part number 660-0205.

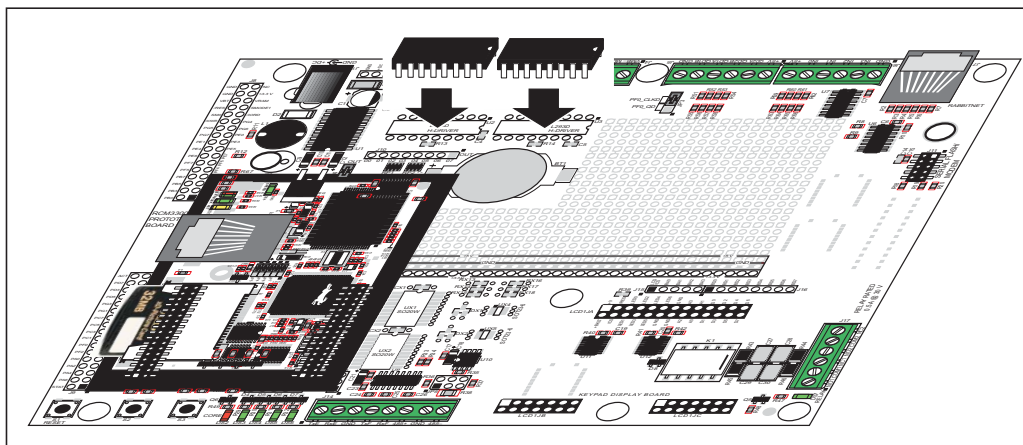

**Figure B-10. Install Four-Channel Push-Pull Driver Chips**

Figure B-11 shows the stepper-motor driver circuit.

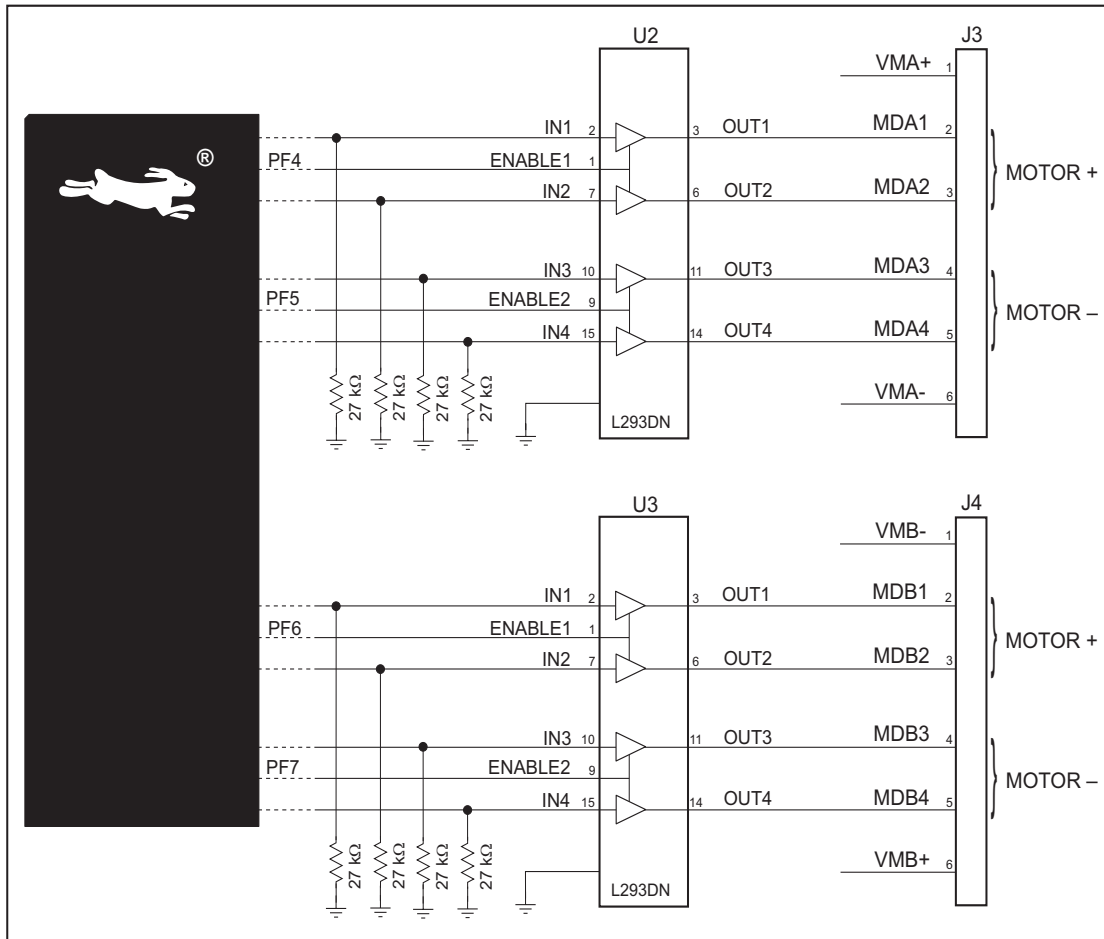

**Figure B-11. Stepper-Motor Driver Circuit**

The stepper motor(s) can be powered either from the onboard power supply or from an external power based on the jumper settings on headers JP1 and JP2.

**Table B-3. Stepper Motor Power-Supply Options**

Header	Pins Connected		Factory Default
JP1	1-2 9-10	Onboard power supply to U2	✗
	3-4 7-8	External power supply to U2	
JP2	1-2 9-10	Onboard power supply to U3	✗
	3-4 7-8	External power supply to U3	

## B.5 Prototyping Board Jumper Configurations

Figure B-12 shows the header locations used to configure the various Prototyping Board options via jumpers.

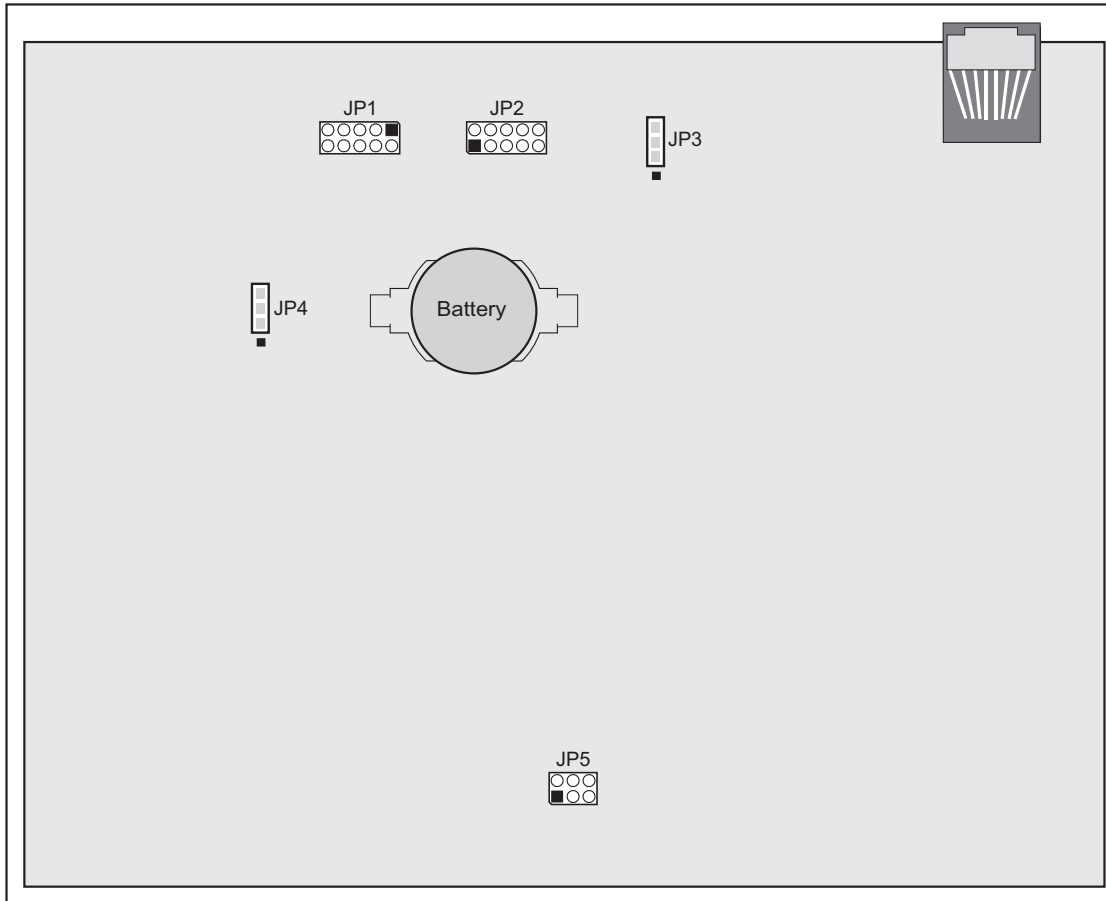

*Figure B-12. Location of Prototyping Board Configurable Positions*



Table B-4 lists the configuration options using jumpers.

**Table B-4. Prototyping Board Jumper Configurations**

Header	Description	Pins Connected		Factory Default
JP1	Stepper Motor Power-Supply Options (U2)	1-2 9-10	Onboard power supply	×
		3-4 7-8	External power supply	
JP2	Stepper Motor Power-Supply Options (U3)	1-2 9-10	Onboard power supply	×
		3-4 7-8	External power supply	
JP3	PF0 Option	1-2	Quadrature decoder inputs enabled	
		2-3	RabbitNet/Serial Flash interface enabled	×
JP4	RCM3365/RCM3375 Power Supply	2-3	RCM3365/RCM3375 powered via Prototyping Board	×
JP5	RS-485 Bias and Termination Resistors	1-2 5-6	Bias and termination resistors connected	×
		1-3 4-6	Bias and termination resistors <i>not</i> connected (parking position for jumpers)	

## B.6 Use of Rabbit 3000 Parallel Ports

Table B-5 lists the Rabbit 3000 parallel ports and their use for the Prototyping Board.

**Table B-5. Prototyping Board Use of Rabbit 3000 Parallel Ports**

Port	I/O	Use	Initial State
PA0–PA3	Data Bus	LCD/keypad module, motor driver, LEDs	Active high
PA4	Data Bus	LCD/keypad module, motor driver, relay and relay LED	Active high
PA5–PA7	Data Bus	LCD/keypad module, motor control	Active high
PB0	Input	CLKB, <i>xD-Picture Card</i> Detect	High
PB1	Input	CLKA Programming Port	High (when not driven by CLKA)
PB2–PB5	Address Bus	LCD/keypad module	High
PB6–PB7	Address Bus	—	High
PC0	Output	TXD SPI, serial flash	Serial Port D High (SPI disabled)
PC1	Input	RXD SPI, serial flash	
PC2	Output	TXC RS-485	Serial Port C High (RS-485 disabled)
PC3	Input	RXC RS-485	
PC4*	Output	TXB	Serial Port B High (disabled)
PC5*	Input	RXB	
PC6	Output	TXA Programming Port	Serial Port A High
PC7	Input	RXA Programming Port	
PD0	Output	RCM3365/RCM3375 <b>USR</b> LED off (shared with NAND flash busy)	High
PD1	Output	Soldered-in NAND flash chip enable	High (disabled)
PD2	Output	SPI, serial flash	Low (SPI disabled)
PD3	Output	SPI, serial flash	High (SPI CS disabled)
PD4–PD6	Input	Serial flash	High (disabled)
PD7	Output	RS-485 Tx enable	Low (RS-485 Tx disabled)
PE0–PE1	Input	IN0–IN1	High
PE2	Output	Ethernet AEN, NAND flash function enable	High (disabled)
PE3	Output	Motor driver A clock pulse	Low (disabled)
PE4–PE5	Input	IN2–IN3, J8	High
PE6	Output	LCD/keypad module	High (disabled)

**Table B-5. Prototyping Board Use of Rabbit 3000 Parallel Ports (continued)**

Port	I/O	Use		Initial State
PE7	Output	Motor driver B clock pulse		High (disabled)
PF0	Input	SPI, serial flash, quadrature decoder		High
PF1–PF3	Input	Quadrature decoder		High
PF4–PF7	Output	Motor 1–4 control		Low (disabled)
PG0	Input	Switch S1		High
PG1	Input	Switch S2		High
PG2	Input	TXF RS-232	Serial Port F	High (RS-232 disabled)
PG3	Input	RXF RS-232		High (RS-232 disabled)
PG4	Output	Motor driver A enable		High (disabled)
PG5	Output	Motor driver B enable		High (disabled)
PG6	Input	TXE RS-232	Serial Port E	High (RS-232 disabled)
PG7	Input	RXE RS-232		High (RS-232 disabled)

\* Not used with RCM3365/RCM3375.



## APPENDIX C. LCD/KEYPAD MODULE

An optional LCD/keypad is available for the Prototyping Board. Appendix C describes the LCD/keypad and provides the software function calls to make full use of the LCD/keypad.

### C.1 Specifications

Two optional LCD/keypad modules—with or without a panel-mounted NEMA 4 water-resistant bezel—are available for use with the Prototyping Board. They are shown in Figure C-1.

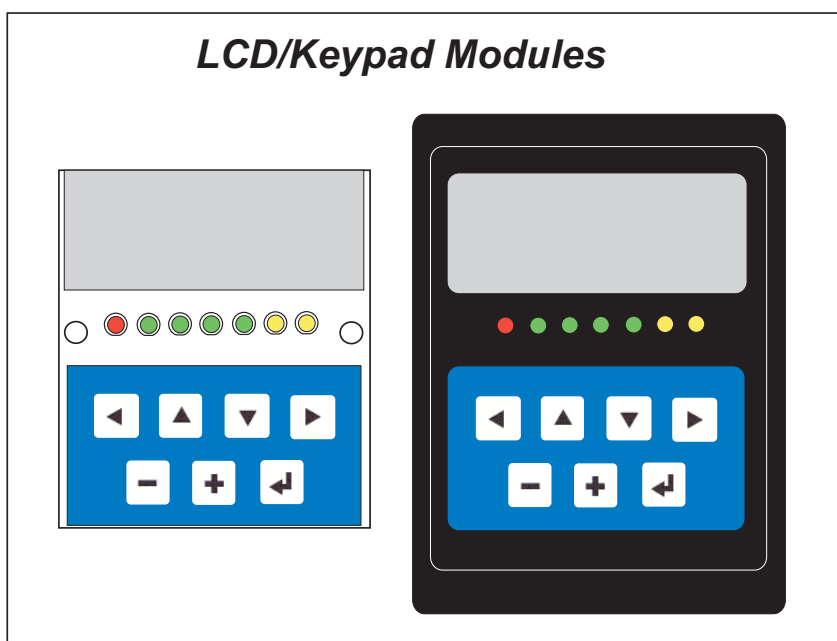

*Figure C-1. LCD/Keypad Modules Versions*

Only the version without the bezel can mount directly on the Prototyping Board; if you have the version with a bezel, you will have to remove the bezel to be able to mount the LCD/keypad module on the Prototyping Board. Either version of the LCD/keypad module can be installed at a remote location up to 60 cm (24") away. Contact your Rabbit sales representative or your authorized distributor for further assistance in purchasing an LCD/keypad module.

Mounting hardware and a 60 cm (24") extension cable are also available for the LCD/keypad module through your sales representative or authorized distributor.

Table C-1 lists the electrical, mechanical, and environmental specifications for the LCD/keypad module.

**Table C-1. LCD/Keypad Specifications**

Parameter	Specification
Board Size	2.60" x 3.00" x 0.75" (66 mm x 76 mm x 19 mm)
Bezel Size	4.50" x 3.60" x 0.30" (114 mm x 91 mm x 7.6 mm)
Temperature	Operating Range: 0°C to +50°C Storage Range: -40°C to +85°C
Humidity	5% to 95%, noncondensing
Power Consumption	1.5 W maximum*
Connections	Connects to high-rise header sockets on the Prototyping Board
LCD Panel Size	122 x 32 graphic display
Keypad	7-key keypad
LEDs	Seven user-programmable LEDs

\* The backlight adds approximately 650 mW to the power consumption.

The LCD/keypad module has 0.1" IDC headers at J1, J2, and J3 for physical connection to other boards or ribbon cables. Figure C-2 shows the LCD/keypad module footprint. These values are relative to one of the mounting holes.

**NOTE:** All measurements are in inches followed by millimeters enclosed in parentheses. All dimensions have a manufacturing tolerance of  $\pm 0.01$ " (0.25 mm).

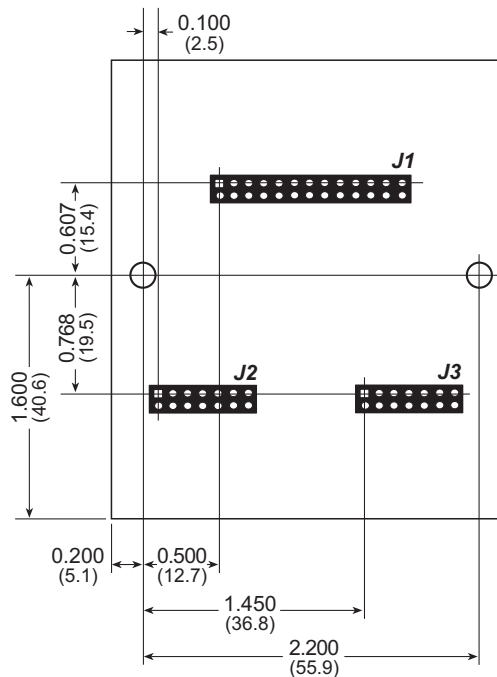

**Figure C-2. User Board Footprint for LCD/Keypad Module**

## C.2 Contrast Adjustments for All Boards

Starting in 2005, LCD/keypad modules were factory-configured to optimize their contrast based on the voltage of the system they would be used in. Be sure to select a KDU3V LCD/keypad module for use with the Prototyping Board for the RCM3365/RCM3375 — these modules operate at 3.3 V. You may adjust the contrast using the potentiometer at R2 as shown in Figure C-3. LCD/keypad modules configured for 5 V may be used with the 3.3 V Prototyping Board, but the backlight will be dim.

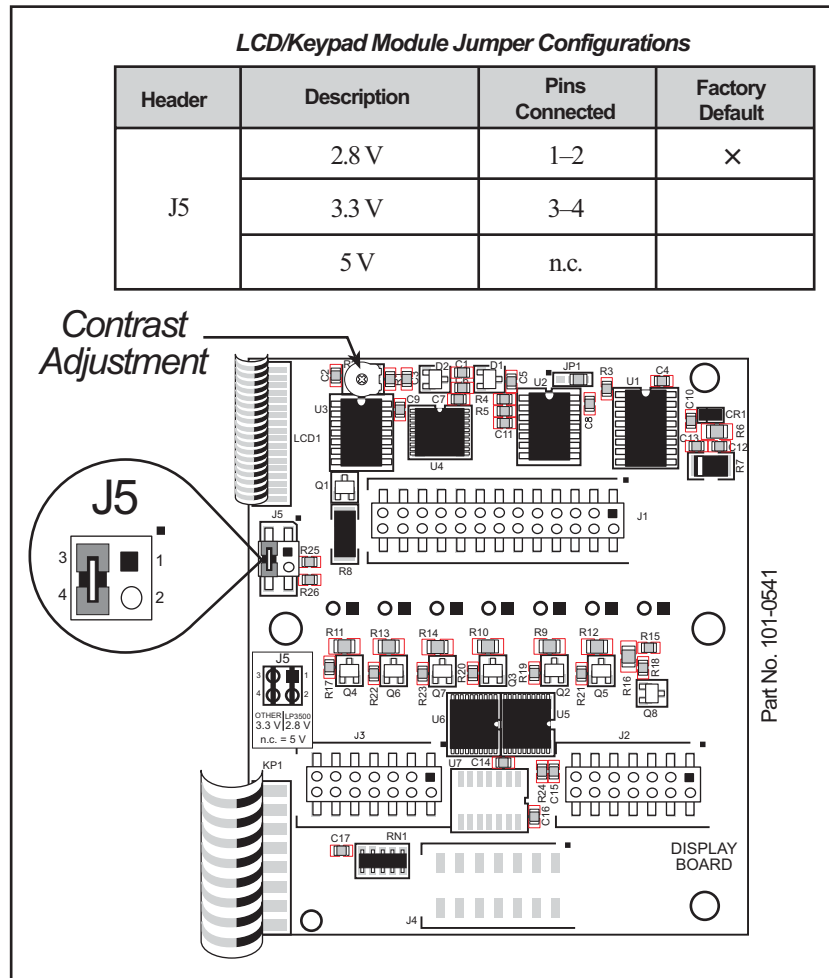

**Figure C-3. LCD/Keypad Module Contrast Adjustments**

You can set the contrast on the LCD display of pre-2005 LCD/keypad modules by adjusting the potentiometer at R2 or by setting the voltage for 3.3 V by connecting the jumper across pins 3–4 on header J5 as shown in Figure C-3. Only one of these two options is available on these LCD/keypad modules.

**NOTE:** Older LCD/keypad modules that do not have a header at J5 or a contrast adjustment potentiometer at R2 are limited to operate only at 5 V, and will not work with the Prototyping Board for the RCM3365/RCM3375. The older LCD/keypad modules are no longer being sold.

### C.3 Keypad Labeling

The keypad may be labeled according to your needs. A template is provided in Figure C-4 to allow you to design your own keypad label insert.

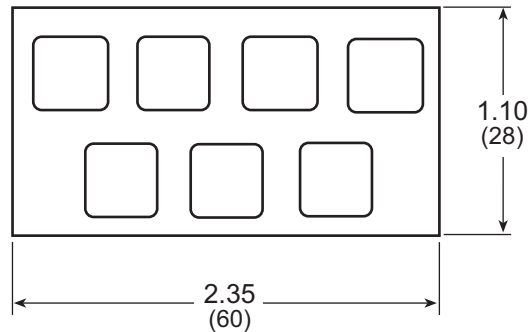

**Figure C-4. Keypad Template**

To replace the keypad legend, remove the old legend and insert your new legend prepared according to the template in Figure C-4. The keypad legend is located under the blue keypad mat, and is accessible from the left only as shown in Figure C-5.

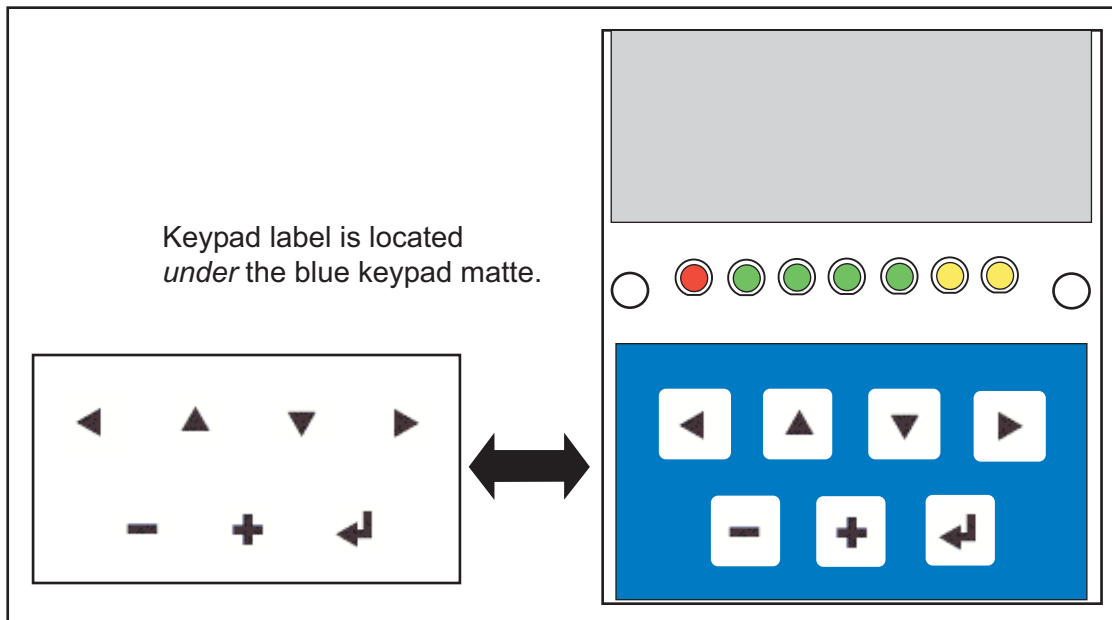

**Figure C-5. Removing and Inserting Keypad Label**

The sample program `KEYBASIC.C` in the `122x32_1x7` folder in `SAMPLES\LCD_KEYPAD` shows how to reconfigure the keypad for different applications.



## C.4 Header Pinouts

Figure C-6 shows the pinouts for the LCD/keypad module.

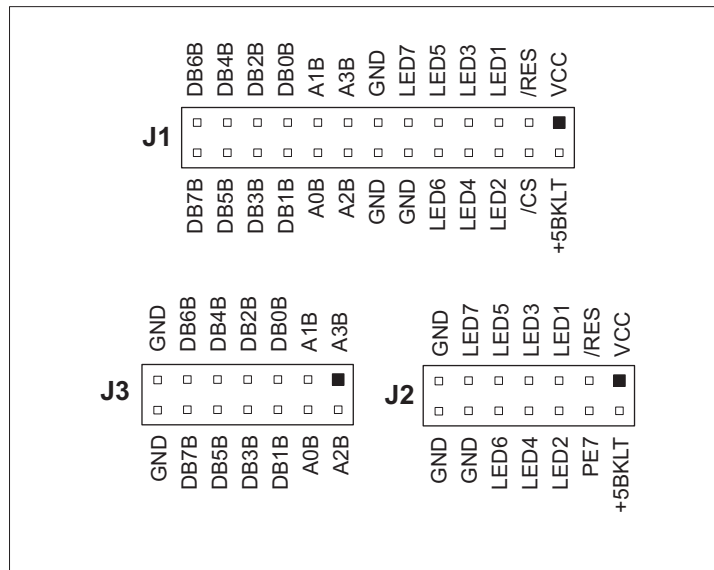

**Figure C-6. LCD/Keypad Module Pinouts**

### C.4.1 I/O Address Assignments

The LCD and keypad on the LCD/keypad module are addressed by the /CS strobe as explained in Table C-2.

**Table C-2. LCD/Keypad Module Address Assignment**

Address	Function
0xE000	Device select base address (/CS)
0xE00–0xE07	LCD control
0xE08	LED enable
0xE09	Not used
0xE0A	7-key keypad
0xE0B (bits 0–6)	7-LED driver
0xE0B (bit 7)	LCD backlight on/off
0xE0C–0xE0F	Not used

## C.5 Mounting LCD/Keypad Module on the Prototyping Board

Install the LCD/keypad module on header sockets LCD1JA, LCD1JB, and LCD1JC of the Prototyping Board as shown in Figure C-7. Be careful to align the pins over the headers, and do not bend them as you press down to mate the LCD/keypad module with the Prototyping Board.

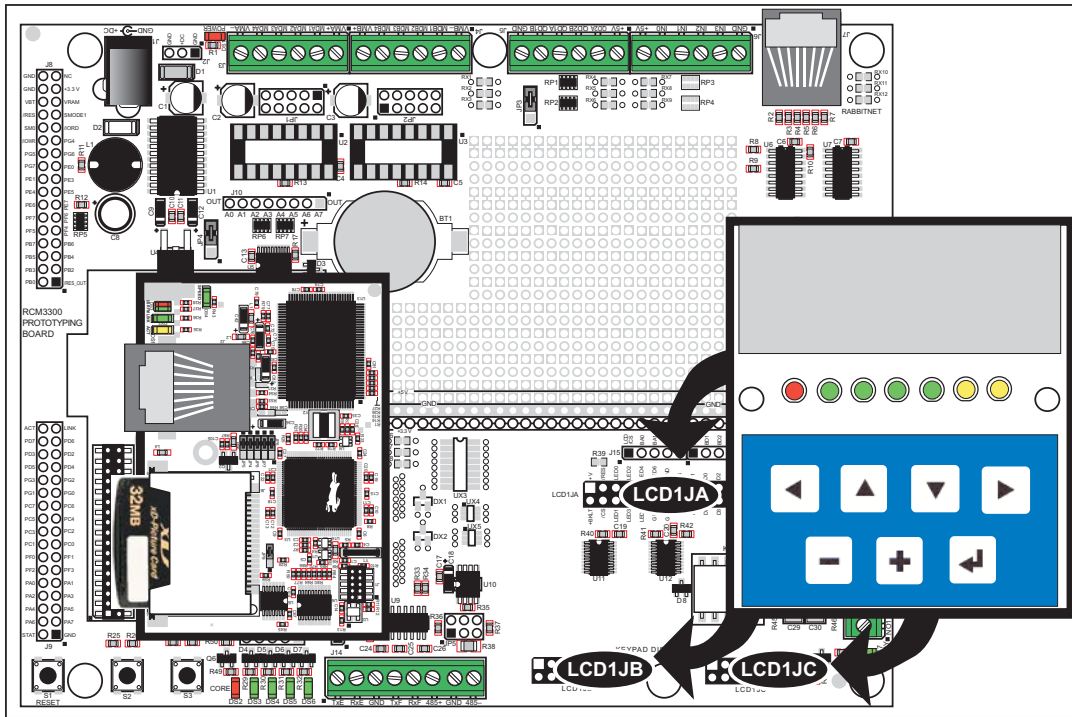
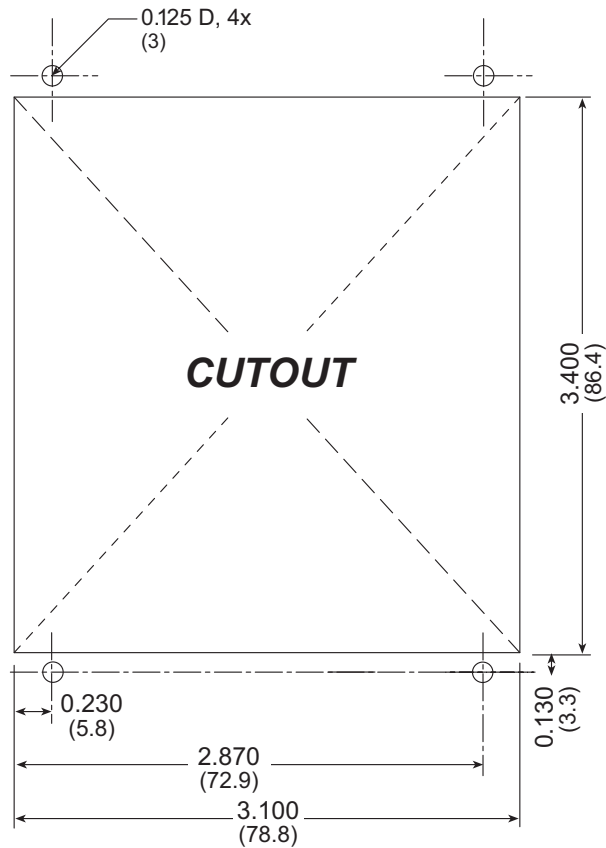

**Figure C-7. Install LCD/Keypad Module on Prototyping Board**

## C.6 Bezel-Mount Installation

This section describes and illustrates how to bezel-mount the LCD/keypad module designed for remote installation. Follow these steps for bezel-mount installation.

1. Cut mounting holes in the mounting panel in accordance with the recommended dimensions in Figure C-8, then use the bezel faceplate to mount the LCD/keypad module onto the panel.



**Figure C-8. Recommended Cutout Dimensions**

2. Carefully “drop in” the LCD/keypad module with the bezel and gasket attached.

3. Fasten the unit with the four 4-40 screws and washers included with the LCD/keypad module. If your panel is thick, use a 4-40 screw that is approximately 3/16" (5 mm) longer than the thickness of the panel.

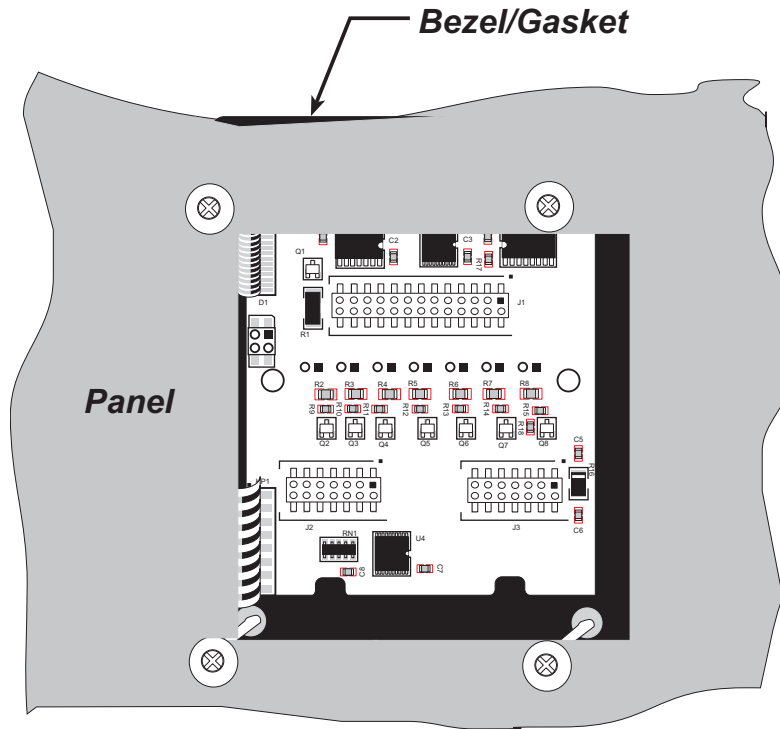

**Figure C-9. LCD/Keypad Module Mounted in Panel (rear view)**

Carefully tighten the screws until the gasket is compressed and the plastic bezel faceplate is touching the panel.

Do not tighten each screw fully before moving on to the next screw. Apply only one or two turns to each screw in sequence until all are tightened manually as far as they can be so that the gasket is compressed and the plastic bezel faceplate is touching the panel.

## C.6.1 Connect the LCD/Keypad Module to Your Prototyping Board

The LCD/keypad module can be located as far as 2 ft. (60 cm) away from the Prototyping Board, and is connected via a ribbon cable as shown in Figure C-10.

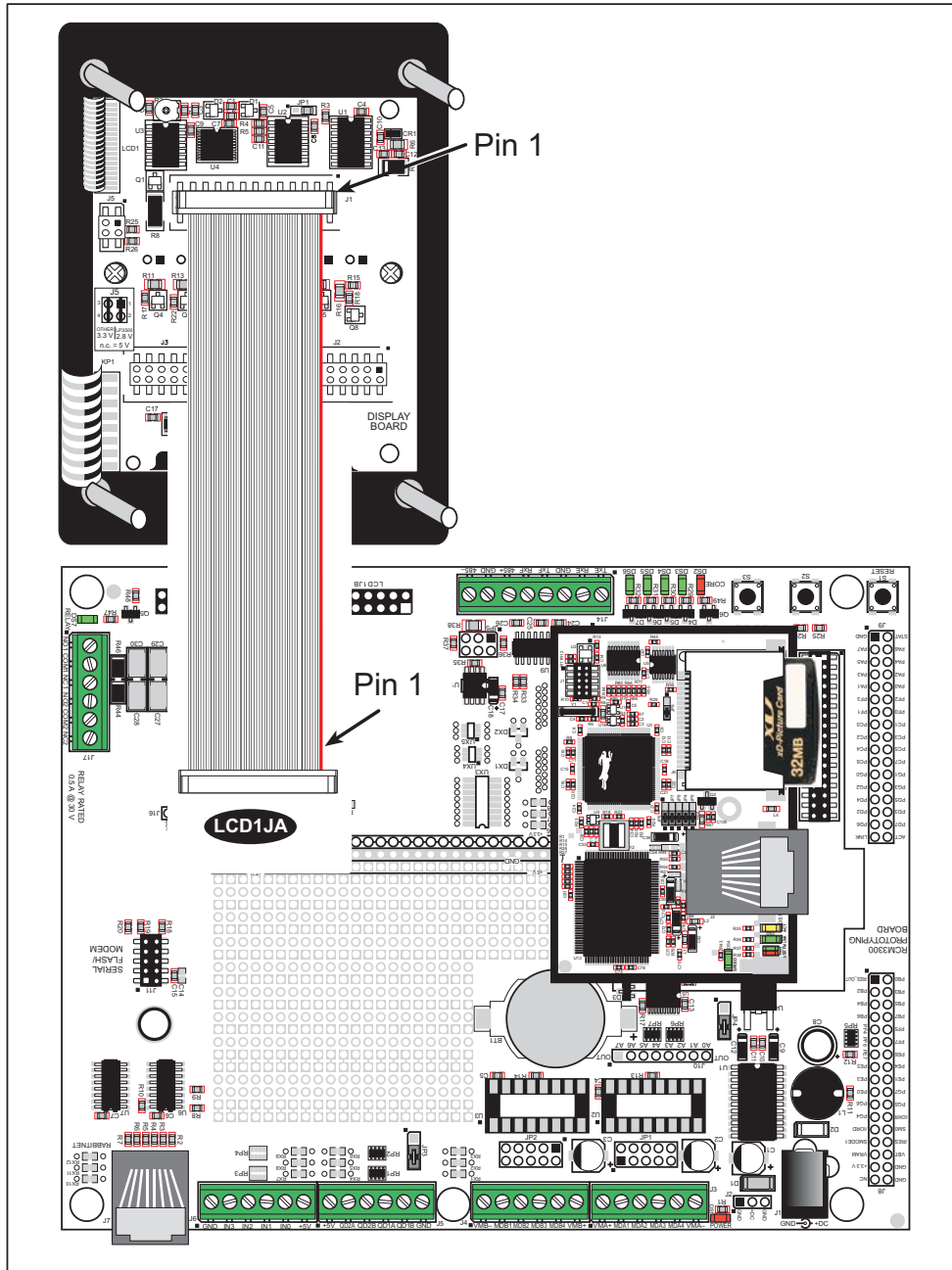

**Figure C-10. Connecting LCD/Keypad Module to Prototyping Board**

Note the locations and connections relative to pin 1 on both the Prototyping Board and the LCD/keypad module.

Rabbit offers 2 ft. (60 cm) extension cables. Contact your authorized distributor or a Rabbit sales representative for more information.

## C.7 Sample Programs

Sample programs illustrating the use of the LCD/keypad module with the Prototyping Board are provided in the `SAMPLES\RCM3360\LCD_KEYPAD` folder.

These sample programs use the external I/O bus on the Rabbit 3000 chip, and so the `#define PORTA_AUX_IO` line is already included in the sample programs.

Each sample program has comments that describe the purpose and function of the program. Follow the instructions at the beginning of the sample program. To run a sample program, open it with the **File** menu (if it is not still open), then compile and run it by pressing **F9**. The RCM3365/RCM3375 must be connected to a PC using the serial programming cable (you also have the option to use an Ethernet cable if the RCM3365 is RabbitSys-enabled) as described in Chapter 2, “Getting Started.”

Complete information on Dynamic C is provided in the *Dynamic C User’s Manual*.

- **KEYPADTOLED.C**—This program demonstrates the use of the external I/O bus. The program will light up an LED on the LCD/keypad module and will display a message on the LCD when a key press is detected. The DS3, DS4, DS5, and DS6 LEDs on the Prototyping Board will also light up. The red LED (DS3) on the RCM3365 module will also light up.
- **LCDKEYFUN.C**—This program demonstrates how to draw primitive features from the graphic library (lines, circles, polygons), and also demonstrates the keypad with the key release option.
- **SWITCHTOLCD.C**—This program demonstrates the use of the external I/O bus. The program will light up an LED on the LCD/keypad module and will display a message on the LCD when a switch press is detected. The DS1 and DS2 LEDs on the Prototyping Board will also light up.

Additional sample programs are available in the `SAMPLES\LCD_KEYPAD\122x32_1x7` folder.

## C.8 LCD/Keypad Module Function Calls

When mounted on the Prototyping Board, the LCD/keypad module uses the external I/O bus on the Rabbit 3000 chip. Remember to add the line

```
#define PORTA_AUX_IO
```

to the beginning of any programs using the external I/O bus.

### C.8.1 LCD/Keypad Module Initialization

The function used to initialize the LCD/keypad module can be found in the Dynamic C `LIB\DISPLAYS\LCD122KEY7.LIB` library.

```
void dispInit();
```

Initializes the LCD/keypad module. The keypad is set up using `keypadDef()` or `keyConfig()` after this function call.

#### RETURN VALUE

None.

### C.8.2 LEDs

When power is applied to the LCD/keypad module for the first time, the red LED (DS1) will come on, indicating that power is being applied to the LCD/keypad module. The red LED is turned off when the `brdInit` function executes.

One function is available to control the LEDs, and can be found in the Dynamic C `LIB\DISPLAYS\LCD122KEY7.LIB` library.

```
void dispLEDOut(int led, int value);
```

LED on/off control. This function will only work when the LCD/keypad module is installed on the Prototyping Board.

#### PARAMETERS

`led` is the LED to control.

- 0 = LED DS1
- 1 = LED DS2
- 2 = LED DS3
- 3 = LED DS4
- 4 = LED DS5
- 5 = LED DS6
- 6 = LED DS7

`value` is the value used to control whether the LED is on or off (0 or 1).

- 0 = off
- 1 = on

#### RETURN VALUE

None.

### C.8.3 LCD Display

The functions used to control the LCD display are contained in the **GRAPHIC.LIB** library located in the Dynamic C **LIB\DISPLAYS\GRAPHIC** library folder. When *x* and *y* coordinates on the display screen are specified, *x* can range from 0 to 121, and *y* can range from 0 to 31. These numbers represent pixels from the top left corner of the display.

```
void glInit(void);
```

Initializes the display devices, clears the screen.

#### RETURN VALUE

None.

#### SEE ALSO

`glDispOnOFF`, `glBacklight`, `glSetContrast`, `glPlotDot`, `glBlock`, `glPlotDot`, `glPlotPolygon`, `glPlotCircle`, `glHScroll`, `glVScroll`, `glXFontInit`, `glPrintf`, `glPutChar`, `glSetBrushType`, `glBuffLock`, `glBuffUnlock`, `glPlotLine`

```
void glBackLight(int onOff);
```

Turns the display backlight on or off.

#### PARAMETER

`onOff` turns the backlight on or off

1—turn the backlight on

0—turn the backlight off

#### RETURN VALUE

None.

#### SEE ALSO

`glInit`, `glDispOnoff`, `glSetContrast`

```
void glDispOnOff(int onOff);
```

Sets the LCD screen on or off. Data will not be cleared from the screen.

#### PARAMETER

`onOff` turns the LCD screen on or off

1—turn the LCD screen on

0—turn the LCD screen off

#### RETURN VALUE

None.

#### SEE ALSO

`glInit`, `glSetContrast`, `glBackLight`



```
void glSetContrast(unsigned level);
```

Sets display contrast.

**NOTE:** This function is not used with the LCD/keypad module since the support circuits are not available on the LCD/keypad module.

```
void glFillScreen(char pattern);
```

Fills the LCD display screen with a pattern.

**PARAMETER**

The screen will be set to all black if **pattern** is 0xFF, all white if **pattern** is 0x00, and vertical stripes for any other pattern.

**RETURN VALUE**

None.

**SEE ALSO**

`glBlock`, `glBlankScreen`, `glPlotPolygon`, `glPlotCircle`

```
void glBlankScreen(void);
```

Blanks the LCD display screen (sets LCD display screen to white).

**RETURN VALUE**

None.

**SEE ALSO**

`glFillScreen`, `glBlock`, `glPlotPolygon`, `glPlotCircle`

```
void glBlock(int x, int y, int bmWidth,  
int bmHeight);
```

Draws a rectangular block in the page buffer and on the LCD if the buffer is unlocked. Any portion of the block that is outside the LCD display area will be clipped.

**PARAMETERS**

**x** is the x coordinate of the top left corner of the block.

**y** is the y coordinate of the top left corner of the block.

**bmWidth** is the width of the block.

**bmHeight** is the height of the block.

**RETURN VALUE**

None.

**SEE ALSO**

`glFillScreen`, `glBlankScreen`, `glPlotPolygon`, `glPlotCircle`

```
void glPlotVPolygon(int n, int *pFirstCoord);
```

Plots the outline of a polygon in the LCD page buffer, and on the LCD if the buffer is unlocked. Any portion of the polygon that is outside the LCD display area will be clipped. If fewer than 3 vertices are specified, the function will return without doing anything.

#### PARAMETERS

**n** is the number of vertices.

**\*pFirstCoord** is a pointer to array of vertex coordinates: **x1,y1, x2,y2, x3,y3,...**

#### RETURN VALUE

None.

#### SEE ALSO

`glPlotPolygon`, `glFillPolygon`, `glFillVPolygon`

```
void glPlotPolygon(int n, int y1, int x2, int y2,  
...);
```

Plots the outline of a polygon in the LCD page buffer and on the LCD if the buffer is unlocked. Any portion of the polygon that is outside the LCD display area will be clipped. If fewer than 3 vertices are specified, the function will return without doing anything.

#### PARAMETERS

**n** is the number of vertices.

**y1** is the y coordinate of the first vertex.

**x1** is the x coordinate of the first vertex.

**y2** is the y coordinate of the second vertex.

**x2** is the x coordinate of the second vertex.

**...** are the coordinates of additional vertices.

#### RETURN VALUE

None.

#### SEE ALSO

`glPlotVPolygon`, `glFillPolygon`, `glFillVPolygon`

```
void glFillVPolygon(int n, int *pFirstCoord);
```

Fills a polygon in the LCD page buffer and on the LCD screen if the buffer is unlocked. Any portion of the polygon that is outside the LCD display area will be clipped. If fewer than 3 vertices are specified, the function will return without doing anything.

#### PARAMETERS

**n** is the number of vertices.

**\*pFirstCoord** is a pointer to array of vertex coordinates: **x1,y1, x2,y2, x3,y3,...**

#### RETURN VALUE

None.

#### SEE ALSO

`glFillPolygon, glPlotPolygon, glPlotVPolygon`

```
void glFillPolygon(int n, int x1, int y1, int x2,  
int y2, ...);
```

Fills a polygon in the LCD page buffer and on the LCD if the buffer is unlocked. Any portion of the polygon that is outside the LCD display area will be clipped. If fewer than 3 vertices are specified, the function will return without doing anything.

#### PARAMETERS

**n** is the number of vertices.

**x1** is the *x* coordinate of the first vertex.

**y1** is the *y* coordinate of the first vertex.

**x2** is the *x* coordinate of the second vertex.

**y2** is the *y* coordinate of the second vertex.

**...** are the coordinates of additional vertices.

#### RETURN VALUE

None.

#### SEE ALSO

`glFillVPolygon, glPlotPolygon, glPlotVPolygon`

```
void glPlotCircle(int xc, int yc, int rad);
```

Draws the outline of a circle in the LCD page buffer and on the LCD if the buffer is unlocked. Any portion of the circle that is outside the LCD display area will be clipped.

#### PARAMETERS

**xc** is the *x* coordinate of the center of the circle.

**yc** is the *y* coordinate of the center of the circle.

**rad** is the radius of the center of the circle (in pixels).

#### RETURN VALUE

None.

#### SEE ALSO

`glFillCircle, glPlotPolygon, glFillPolygon`

```
void glFillColor(int xc, int yc, int rad);
```

Draws a filled circle in the LCD page buffer and on the LCD if the buffer is unlocked. Any portion of the circle that is outside the LCD display area will be clipped.

#### PARAMETERS

**xc** is the x coordinate of the center of the circle.

**yc** is the y coordinate of the center of the circle.

**rad** is the radius of the center of the circle (in pixels).

#### RETURN VALUE

None.

#### SEE ALSO

`glPlotCircle`, `glPlotPolygon`, `glFillPolygon`

```
void glXFontInit(fontInfo *pInfo, char pixWidth,  
char pixHeight, unsigned startChar,  
unsigned endChar, unsigned long xmemBuffer);
```

Initializes the font descriptor structure, where the font is stored in **xmem**.

#### PARAMETERS

**\*pInfo** is a pointer to the font descriptor to be initialized.

**pixWidth** is the width (in pixels) of each font item.

**pixHeight** is the height (in pixels) of each font item.

**startChar** is the value of the first printable character in the font character set.

**endChar** is the value of the last printable character in the font character set.

**xmemBuffer** is the **xmem** pointer to a linear array of font bitmaps.

#### RETURN VALUE

None.

#### SEE ALSO

`glPrintf`

```
unsigned long glFontCharAddr(fontInfo *pInfo,
char letter);
```

Returns the **xmem** address of the character from the specified font set.

#### PARAMETERS

**\*pInfo** is the **xmem** address of the bitmap font set.

**letter** is an ASCII character.

#### RETURN VALUE

**xmem** address of bitmap character font, column major, and byte-aligned.

#### SEE ALSO

`glPutFont`, `glPrintf`

```
void glPutFont(int x, int y, fontInfo *pInfo,
char code);
```

Puts an entry from the font table to the page buffer and on the LCD if the buffer is unlocked. Each font character's bitmap is column major and byte-aligned. Any portion of the bitmap character that is outside the LCD display area will be clipped.

#### PARAMETERS

**x** is the *x* coordinate (column) of the top left corner of the text.

**y** is the *y* coordinate (row) of the top left corner of the text.

**\*pInfo** is a pointer to the font descriptor.

**code** is the ASCII character to display.

#### RETURN VALUE

None.

#### SEE ALSO

`glFontCharAddr`, `glPrintf`

```
void glSetPfStep(int stepX, int stepY);
```

Sets the `glPrintf()` printing step direction. The *x* and *y* step directions are independent signed values. The actual step increments depend on the height and width of the font being displayed, which are multiplied by the step values.

#### PARAMETERS

**stepX** is the `glPrintf` *x* step value

**stepY** is the `glPrintf` *y* step value

#### RETURN VALUE

None.

#### SEE ALSO

Use `glGetPfStep()` to examine the current *x* and *y* printing step direction.

```
int glGetPfStep(void);
```

Gets the current `glPrintf()` printing step direction. Each step direction is independent of the other, and is treated as an 8-bit signed value. The actual step increments depends on the height and width of the font being displayed, which are multiplied by the step values.

#### RETURN VALUE

The *x* step is returned in the MSB, and the *y* step is returned in the LSB of the integer result.

#### SEE ALSO

Use `glGetPfStep()` to control the *x* and *y* printing step direction.

```
void glPutChar(char ch, char *ptr, int *cnt,  
glPutCharInst *pInst)
```

Provides an interface between the **STDIO** string-handling functions and the graphic library. The **STDIO** string-formatting function will call this function, one character at a time, until the entire formatted string has been parsed. Any portion of the bitmap character that is outside the LCD display area will be clipped.

#### PARAMETERS

`ch` is the character to be displayed on the LCD.

`*ptr` is not used, but is a place holder for **STDIO** string functions.

`*cnt` is not used, is a place holder for **STDIO** string functions.

`*pInst` is a font descriptor pointer.

#### RETURN VALUE

None.

#### SEE ALSO

`glPrintf`, `glPutFont`, `doprnt`

```
void glPrintf(int x, int y, fontInfo *pInfo,  
char *fmt, ...);
```

Prints a formatted string (much like `printf`) on the LCD screen. Only the character codes that exist in the font set are printed, all others are skipped. For example, `'\b'`, `'\t'`, `'\n'` and `'\r'` (ASCII backspace, tab, new line, and carriage return, respectively) will be printed if they exist in the font set, but will not have any effect as control characters. Any portion of the bitmap character that is outside the LCD display area will be clipped.

#### PARAMETERS

`x` is the *x* coordinate (column) of the top left corner of the text.

`y` is the *y* coordinate (row) of the top left corner of the text.

`*pInfo` is a font descriptor pointer.

`*fmt` is a formatted string.

`...` are formatted string conversion parameter(s).

#### EXAMPLE

```
glprintf(0,0, &fi12x16, "Test %d\n", count);
```

#### RETURN VALUE

None.

#### SEE ALSO

`glXFontInit`

```
void glBuffLock(void);
```

Increments LCD screen locking counter. Graphic calls are recorded in the LCD memory buffer and are not transferred to the LCD if the counter is non-zero.

**NOTE:** `glBuffLock()` and `glBuffUnlock()` can be nested up to a level of 255, but be sure to balance the calls. It is not a requirement to use these procedures, but a set of `glBuffLock()` and `glBuffUnlock()` bracketing a set of related graphic calls speeds up the rendering significantly.

#### RETURN VALUE

None.

#### SEE ALSO

`glBuffUnlock`, `glSwap`

```
void glBuffUnlock(void);
```

Decrements the LCD screen locking counter. The contents of the LCD buffer are transferred to the LCD if the counter goes to zero.

#### RETURN VALUE

None.

#### SEE ALSO

`glBuffLock`, `glSwap`

## **void glSwap(void);**

Checks the LCD screen locking counter. The contents of the LCD buffer are transferred to the LCD if the counter is zero.

### **RETURN VALUE**

None.

### **SEE ALSO**

`glBuffUnlock`, `glBuffLock`, `_glSwapData` (located in the library specifically for the LCD that you are using)

## **void glSetBrushType(int type);**

Sets the drawing method (or color) of pixels drawn by subsequent graphic calls.

### **PARAMETER**

`type` value can be one of the following macros.

`PIXBLACK` draws black pixels (turns pixel on).

`PIXWHITE` draws white pixels (turns pixel off).

`PIXXOR` draws old pixel XOR'ed with the new pixel.

### **RETURN VALUE**

None.

### **SEE ALSO**

`glGetBrushType`

## **int glGetBrushType(void);**

Gets the current method (or color) of pixels drawn by subsequent graphic calls.

### **RETURN VALUE**

The current brush type.

### **SEE ALSO**

`glSetBrushType`

## **void glPlotDot(int x, int y);**

Draws a single pixel in the LCD buffer, and on the LCD if the buffer is unlocked. If the coordinates are outside the LCD display area, the dot will not be plotted.

### **PARAMETERS**

`x` is the *x* coordinate of the dot.

`y` is the *y* coordinate of the dot.

### **RETURN VALUE**

None.

### **SEE ALSO**

`glPlotline`, `glPlotPolygon`, `glPlotCircle`



```
void glPlotLine(int x0, int y0, int x1, int y1);
```

Draws a line in the LCD buffer, and on the LCD if the buffer is unlocked. Any portion of the line that is beyond the LCD display area will be clipped.

#### PARAMETERS

**x0** is the *x* coordinate of one endpoint of the line.

**y0** is the *y* coordinate of one endpoint of the line.

**x1** is the *x* coordinate of the other endpoint of the line.

**y1** is the *y* coordinate of the other endpoint of the line.

#### RETURN VALUE

None.

#### SEE ALSO

`glPlotDot`, `glPlotPolygon`, `glPlotCircle`

```
void glLeft1(int left, int top, int cols, int rows);
```

Scrolls byte-aligned window left one pixel, right column is filled by current pixel type (color).

#### PARAMETERS

**left** is the top left corner of bitmap, must be evenly divisible by 8, otherwise truncates.

**top** is the top left corner of the bitmap.

**cols** is the number of columns in the window, must be evenly divisible by 8, otherwise truncates.

**rows** is the number of rows in the window.

#### RETURN VALUE

None.

#### SEE ALSO

`glHScroll`, `glRight1`

```
void glRight1(int left, int top, int cols, int rows);
```

Scrolls byte-aligned window right one pixel, left column is filled by current pixel type (color).

#### PARAMETERS

**left** is the top left corner of bitmap, must be evenly divisible by 8, otherwise truncates.

**top** is the top left corner of the bitmap.

**cols** is the number of columns in the window, must be evenly divisible by 8, otherwise truncates.

**rows** is the number of rows in the window.

#### RETURN VALUE

None.

#### SEE ALSO

`glHScroll`, `glLeft1`

```
void glUp1(int left, int top, int cols, int rows);
```

Scrolls byte-aligned window up one pixel, bottom column is filled by current pixel type (color).

#### PARAMETERS

**left** is the top left corner of bitmap, must be evenly divisible by 8, otherwise truncates.

**top** is the top left corner of the bitmap.

**cols** is the number of columns in the window, must be evenly divisible by 8, otherwise truncates.

**rows** is the number of rows in the window.

#### RETURN VALUE

None.

#### SEE ALSO

`glVScroll`, `glDown1`

```
void glDown1(int left, int top, int cols, int rows);
```

Scrolls byte-aligned window down one pixel, top column is filled by current pixel type (color).

#### PARAMETERS

**left** is the top left corner of bitmap, must be evenly divisible by 8, otherwise truncates.

**top** is the top left corner of the bitmap.

**cols** is the number of columns in the window, must be evenly divisible by 8, otherwise truncates.

**rows** is the number of rows in the window.

#### RETURN VALUE

None.

#### SEE ALSO

`glVScroll`, `glUp1`

```
void glHScroll(int left, int top, int cols,  
int rows, int nPix);
```

Scrolls right or left, within the defined window by  $x$  number of pixels. The opposite edge of the scrolled window will be filled in with white pixels. The window must be byte-aligned.

Parameters will be verified for the following:

1. The **left** and **cols** parameters will be verified that they are evenly divisible by 8. If not, they will be truncated to a value that is a multiple of 8.
2. Parameters will be checked to verify that the scrolling area is valid. The minimum scrolling area is a width of 8 pixels and a height of one row.

#### **PARAMETERS**

**left** is the top left corner of bitmap, must be evenly divisible by 8.

**top** is the top left corner of the bitmap.

**cols** is the number of columns in the window, must be evenly divisible by 8.

**rows** is the number of rows in the window.

**nPix** is the number of pixels to scroll within the defined window (a negative value will produce a scroll to the left).

#### **RETURN VALUE**

None.

#### **SEE ALSO**

`glVScroll`

```
void glVScroll(int left, int top, int cols,
               int rows, int nPix);
```

Scrolls up or down, within the defined window by  $x$  number of pixels. The opposite edge of the scrolled window will be filled in with white pixels. The window must be byte-aligned.

Parameters will be verified for the following:

1. The **left** and **cols** parameters will be verified that they are evenly divisible by 8. If not, they will be truncated to a value that is a multiple of 8.
2. Parameters will be checked to verify that the scrolling area is valid. The minimum scrolling area is a width of 8 pixels and a height of one row.

#### PARAMETERS

**left** is the top left corner of bitmap, must be evenly divisible by 8.

**top** is the top left corner of the bitmap.

**cols** is the number of columns in the window, must be evenly divisible by 8.

**rows** is the number of rows in the window.

**nPix** is the number of pixels to scroll within the defined window (a negative value will produce a scroll up).

#### RETURN VALUE

None.

#### SEE ALSO

`glHScroll`

```
void glXPutBitmap(int left, int top, int width,
                  int height, unsigned long bitmap);
```

Draws bitmap in the specified space. The data for the bitmap are stored in **xmem**. This function calls `glXPutFastmap` automatically if the bitmap is byte-aligned (the left edge and the width are each evenly divisible by 8).

Any portion of a bitmap image or character that is outside the LCD display area will be clipped.

#### PARAMETERS

**left** is the top left corner of the bitmap.

**top** is the top left corner of the bitmap.

**width** is the width of the bitmap.

**height** is the height of the bitmap.

**bitmap** is the address of the bitmap in **xmem**.

#### RETURN VALUE

None.

#### SEE ALSO

`glXPutFastmap`, `glPrintf`

```
void glXPutFastmap(int left, int top, int width,
                  int height, unsigned long bitmap);
```

Draws bitmap in the specified space. The data for the bitmap are stored in `xmem`. This function is like `glXPutBitmap`, except that it is faster. The restriction is that the bitmap must be byte-aligned.

Any portion of a bitmap image or character that is outside the LCD display area will be clipped.

#### PARAMETERS

`left` is the top left corner of the bitmap, must be evenly divisible by 8, otherwise truncates.

`top` is the top left corner of the bitmap.

`width` is the width of the bitmap, must be evenly divisible by 8, otherwise truncates.

`height` is the height of the bitmap.

`bitmap` is the address of the bitmap in `xmem`.

#### RETURN VALUE

None.

#### SEE ALSO

`glXPutBitmap`, `glPrintf`

```
int TextWindowFrame(windowFrame *window,
                   fontInfo *pFont, int x, int y, int winWidth,
                   int winHeight)
```

Defines a text-only display window. This function provides a way to display characters within the text window using only character row and column coordinates. The text window feature provides end-of-line wrapping and clipping after the character in the last column and row is displayed.

**NOTE:** Execute the `TextWindowFrame` function before other `Text...` functions.

#### PARAMETERS

`*window` is a window frame descriptor pointer.

`*pFont` is a font descriptor pointer.

`x` is the *x* coordinate of the top left corner of the text window frame.

`y` is the *y* coordinate of the top left corner of the text window frame.

`winWidth` is the width of the text window frame.

`winHeight` is the height of the text window frame.

#### RETURN VALUE

0—window frame was successfully created.

-1—*x* coordinate + width has exceeded the display boundary.

-2—*y* coordinate + height has exceeded the display boundary.

```
void TextGotoXY(windowFrame *window, int col,
int row);
```

Sets the cursor location to display the next character. The display location is based on the height and width of the character to be displayed.

**NOTE:** Execute the `TextWindowFrame` function before using this function.

#### PARAMETERS

**\*window** is a pointer to a font descriptor.

**col** is a character column location.

**row** is a character row location.

#### RETURN VALUE

None.

#### SEE ALSO

`TextPutChar`, `TextPrintf`, `TextWindowFrame`

```
void TextCursorPosition(windowFrame *window,
int *col, int *row);
```

Gets the current cursor location that was set by a Graphic `Text...` function.

**NOTE:** Execute the `TextWindowFrame` function before using this function.

#### PARAMETERS

**\*window** is a pointer to a font descriptor.

**\*col** is a pointer to cursor column variable.

**\*row** is a pointer to cursor row variable.

#### RETURN VALUE

Lower word = Cursor Row location

Upper word = Cursor Column location

#### SEE ALSO

`TextGotoXY`, `TextPrintf`, `TextWindowFrame`, `TextCursorPosition`

```
void TextPutChar(struct windowFrame *window, char ch);
```

Displays a character on the display where the cursor is currently pointing. If any portion of a bitmap character is outside the LCD display area, the character will not be displayed. The cursor increments its position as needed.

**NOTE:** Execute the `TextWindowFrame` function before using this function.

#### PARAMETERS

`*window` is a pointer to a font descriptor.

`ch` is a character to be displayed on the LCD.

#### RETURN VALUE

None.

#### SEE ALSO

`TextGotoXY`, `TextPrintf`, `TextWindowFrame`, `TextCursorLocation`

```
void TextPrintf(struct windowFrame *window,  
char *fmt, ...);
```

Prints a formatted string (much like `printf`) on the LCD screen. Only printable characters in the font set are printed, also escape sequences, `\r` and `\n` are recognized. All other escape sequences will be skipped over; for example, `\b` and `\t` will print if they exist in the font set, but will not have any effect as control characters.

The text window feature provides end-of-line wrapping and clipping after the character in the last column and row is displayed. The cursor then remains at the end of the string.

**NOTE:** Execute the `TextWindowFrame` function before using this function.

#### PARAMETERS

`*window` is a pointer to a font descriptor.

`*fmt` is a formatted string.

`...` are formatted string conversion parameter(s).

#### EXAMPLE

```
TextPrintf(&TextWindow, "Test %d\n", count);
```

#### RETURN VALUE

None.

#### SEE ALSO

`TextGotoXY`, `TextPutChar`, `TextWindowFrame`, `TextCursorLocation`

## C.8.4 Keypad

The functions used to control the keypad are contained in the `KEYPAD7.LIB` library located in the Dynamic C `KEYPADS` library folder.

```
void keyInit(void);
```

Initializes keypad process

### RETURN VALUE

None.

### SEE ALSO

`brdInit`

```
void keyConfig(char cRaw, char cPress,  
char cRelease, char cCntHold, char cSpdLo,  
char cCntLo, char cSpdHi);
```

Assigns each key with key press and release codes, and hold and repeat ticks for auto repeat and debouncing.

### PARAMETERS

`cRaw` is a raw key code index.

1x7 keypad matrix with raw key code index assignments (in brackets):

[0]	[1]	[2]	[3]
[4]	[5]	[6]	

### User Keypad Interface

`cPress` is a key press code

An 8-bit value is returned when a key is pressed.

0 = Unused.

See `keypadDef()` for default press codes.

`cRelease` is a key release code.

An 8-bit value is returned when a key is pressed.

0 = Unused.

`cCntHold` is a hold tick, which is approximately one debounce period or 5  $\mu$ s.

How long to hold before repeating.

0 = No Repeat.

`cSpdLo` is a low-speed repeat tick, which is approximately one debounce period or 5  $\mu$ s.

How many times to repeat.

0 = None.

`cCntLo` is a low-speed hold tick, which is approximately one debounce period or 5  $\mu$ s.

How long to hold before going to high-speed repeat.

0 = Slow Only.



`cSpdHi` is a high-speed repeat tick, which is approximately one debounce period or 5  $\mu$ s.

How many times to repeat after low speed repeat.

0 = None.

**RETURN VALUE**

None.

**SEE ALSO**

`keyProcess`, `keyGet`, `keypadDef`

## `void keyProcess(void);`

Scans and processes keypad data for key assignment, debouncing, press and release, and repeat.

**NOTE:** This function is also able to process an 8 x 8 matrix keypad.

**RETURN VALUE**

None

**SEE ALSO**

`keyConfig`, `keyGet`, `keypadDef`

## `char keyGet(void);`

Get next keypress.

**RETURN VALUE**

The next keypress, or 0 if none

**SEE ALSO**

`keyConfig`, `keyProcess`, `keypadDef`

## `int keyUnget(char cKey);`

Pushes the value of `cKey` to the top of the input queue, which is 16 bytes deep.

**PARAMETER**

`cKey`

**RETURN VALUE**

None.

**SEE ALSO**

`keyGet`

## void keypadDef();

Configures the physical layout of the keypad with the default ASCII return key codes.

Keypad physical mapping 1 x 7

0	4	1	5	2	6	3
['L']		['U']		['D']		['R']
	['-']		['+']		['E']	

where

'D' represents Down Scroll

'U' represents Up Scroll

'R' represents Right Scroll

'L' represents Left Scroll

'-' represents Page Down

'+' represents Page Up

'E' represents the ENTER key

**Example:** Do the following for the above physical vs. ASCII return key codes.

```
keyConfig ( 3, 'R', 0, 0, 0, 0, 0 );
keyConfig ( 6, 'E', 0, 0, 0, 0, 0 );
keyConfig ( 2, 'D', 0, 0, 0, 0, 0 );
keyConfig ( 4, '-', 0, 0, 0, 0, 0 );
keyConfig ( 1, 'U', 0, 0, 0, 0, 0 );
keyConfig ( 5, '+', 0, 0, 0, 0, 0 );
keyConfig ( 0, 'L', 0, 0, 0, 0, 0 );
```

Characters are returned upon keypress with no repeat.

### RETURN VALUE

None.

### SEE ALSO

`keyConfig`, `keyGet`, `keyProcess`

## void keyScan(char \*pcKeys);

Writes "1" to each row and reads the value. The position of a keypress is indicated by a zero value in a bit position.

### PARAMETER

`*pcKeys` is a pointer to the address of the value read.

### RETURN VALUE

None.

### SEE ALSO

`keyConfig`, `keyGet`, `keypadDef`, `keyProcess`

## APPENDIX D. POWER SUPPLY

Appendix D provides information on the current requirements of the RCM3365/RCM3375 modules, and includes some background on the reset generator.

### D.1 Power Supplies

Power is supplied from the motherboard to which the RCM3365/RCM3375 is connected via header J4. The RCM3365/RCM3375 require a regulated 3.15 V to 3.45 V DC power source. An RCM3365/RCM3375 with no loading at the outputs operating at 44.2 MHz typically draws 250 mA.

#### D.1.1 Battery Backup

The RCM3365/RCM3375 does not have a battery, but there is provision for a customer-supplied battery to back up the data SRAM and keep the internal Rabbit 3000 real-time clock running.

**NOTE:** A backup battery is highly recommended to back up the data SRAM when using an RCM3365 with Dynamic C RabbitSys to keep RabbitSys from reverting to its default settings in case of a power failure.

Header J4, shown in Figure D-1, allows access to the external battery. This header makes it possible to connect an external 3 V power supply. This allows the SRAM and the internal Rabbit 3000 real-time clock to retain data with the RCM3365/RCM3375 powered down.

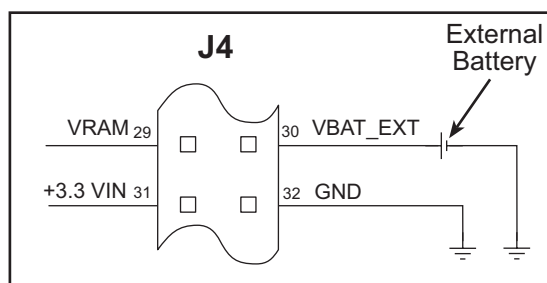

**Figure D-1. External Battery Connections at Header J4**

A lithium battery with a nominal voltage of 3 V and a minimum capacity of 165 mA·h is recommended. A lithium battery is strongly recommended because of its nearly constant nominal voltage over most of its life.

The drain on the battery by the RCM3365/RCM3375 is typically 6  $\mu$ A when no other power is supplied. If a 165 mA·h battery is used, the battery can last about 3 years:

$$\frac{165 \text{ mA}\cdot\text{h}}{6 \mu\text{A}} = 3.1 \text{ years.}$$

The RCM3365/RCM3375 module does not drain the battery while it is powered up normally.

Cycle the main power off/on on the RCM3365/RCM3375 after you install a backup battery for the first time, and whenever you replace the battery. This step will minimize the current drawn by the real-time clock oscillator circuit from the backup battery should the RCM3365/RCM3375 experience a loss of main power.

**NOTE:** Remember to cycle the main power off/on any time the RCM3365/RCM3375 is removed from the Prototyping Board or motherboard since that is where the backup battery would be located.

Rabbit's Technical Note TN235, *External 32.768 kHz Oscillator Circuits*, provides additional information about the current draw by the real-time clock oscillator circuit.

### D.1.2 Battery-Backup Circuit

Figure D-2 shows the battery-backup circuit.

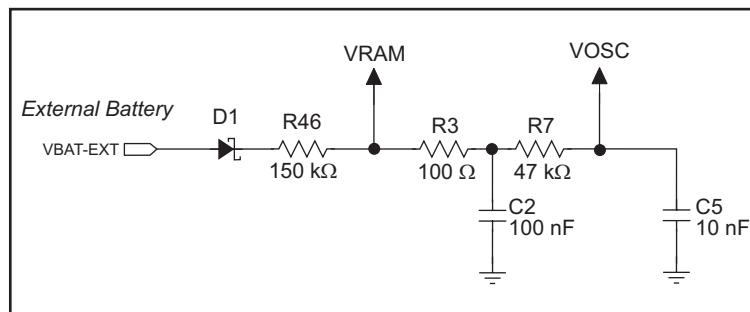

**Figure D-2. RCM3365/RCM3375 Backup Battery Circuit**

The battery-backup circuit serves three purposes:

- It reduces the battery voltage to the SRAM and to the real-time clock, thereby limiting the current consumed by the real-time clock and lengthening the battery life.
- It ensures that current can flow only *out* of the battery to prevent charging the battery.
- A voltage, VOSC, is supplied to U1, which keeps the 32.768 kHz oscillator working when the voltage begins to drop.

### **D.1.3 Reset Generator**

The RCM3365/RCM3375 uses a reset generator to reset the Rabbit 3000 microprocessor when the voltage drops below the voltage necessary for reliable operation. The reset occurs between 2.85 V and 3.00 V, typically 2.93 V.

The RCM3365/RCM3375 has a reset pin, pin 28 on header J4. This pin provides access to the reset input of the reset generator, whose output drives the reset input of the Rabbit 3000 and peripheral circuits. The /RESET output from the reset generator is available on pin 1 of header J4 on the RCM3365/RCM3375, and can be used to reset user-defined circuits on the motherboard on which the RCM3365/RCM3375 module is mounted.





## APPENDIX E. PROGRAMMING VIA ETHERNET CROSSOVER CABLE

A RabbitSys-enabled RCM3365 module can also be programmed with a CAT5/6 Ethernet crossover cable connecting the RCM3365 module directly to a PC or notebook. This appendix describes the connection and how to set up the TCP/IP parameters.

Section 2, “Getting Started,” describes how to connect a PC, notebook, or workstation to an RCM3365 module via a serial programming cable or via a CAT 5/6 Ethernet cable. A CAT 5/6 crossover Ethernet cable can be used to connect an RCM3365 module directly to a PC, notebook, or workstation, but the TCP/IP parameters have to be entered into the RCM3365 module and on to the PC, notebook, or workstation if the PC, notebook, or workstation does not have a DHCP server. This appendix explains how to load the TCP/IP parameters when the PC, notebook, or workstation if the PC, notebook, or workstation does not have a DHCP server.

## E.1 Load TCP/IP Parameters to the RCM3365 Module

1. Connect the 10-pin **PROG** connector of the serial programming cable to header J1 on the RCM3365 module as described in Section 2.2.2. (Do not use the **DIAG** connector.)
2. Use the **File** menu to open the sample program **SETUPFORCROSSOVER.C**, which is in the Dynamic C **SAMPLES\RABBITSYS** folder. Press function key **F9** to compile and run the program.

This sample program brings down the Ethernet interface, turns off DHCP, sets the RCM3365's IP address to 10.10.6.100, sets the netmask to 255.255.255.0, and sets the default gateway to 10.10.6.1. The RCM3365 module is now set up.

The IP and gateway addresses can be changed in the two macros in the two macros at the beginning of the sample program:

```
#define _IPADDR"10.10.6.100"  
#define _GATEWAY"10.10.6.1"
```

To restore the RCM3365 to its default DHCP behavior, uncomment the **ENABLE\_DHCP** macro:

```
//#define ENABLE_DHCP
```



## E.2 Load TCP/IP Parameters to the PC, Notebook, or Workstation

If the PC, notebook, or workstation is connected to a network, disconnect it from the network. Check with your administrator if you are unable to change the settings as described here since you may need administrator privileges. The screen shots shown here are from Windows 2000, and the interface is similar for other versions of Windows.

1. Go to the control panel (**Start > Settings > Control Panel**) and start **Network Connections**.



2. Select the network interface card used for the Ethernet interface you intend to use (e.g., **TCP/IP Xircom Credit Card Network Adapter**) and click on the "Properties" button. Depending on which version of Windows your PC is running, you may have to select the "Local Area Connection" first, and then click on the "Properties" button to bring up the Ethernet interface dialog. Then "Configure" your interface card for a "10Base-T Half-Duplex" or an "Auto-Negotiation" connection on the "Advanced" tab.

**NOTE:** Your network interface card will likely have a different name.

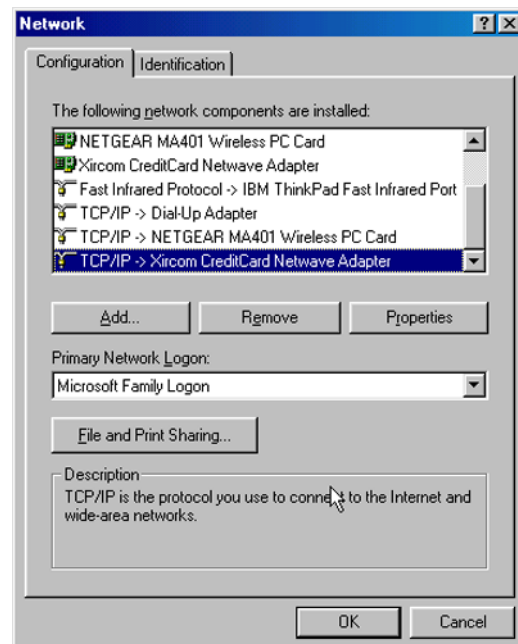

3. Now select the **IP Address** tab, and check **Specify an IP Address**, or select TCP/IP and click on “Properties” to fill in the following fields:

IP Address : 10.10.6.101

Netmask : 255.255.255.0

Default gateway : 10.10.6.1

**TIP:** If you are using a PC that is normally on a network, you will have disconnected the PC from that network. Write down the existing settings before changing them to facilitate restoring them when you are finished with the sample programs and reconnect your PC to the network.

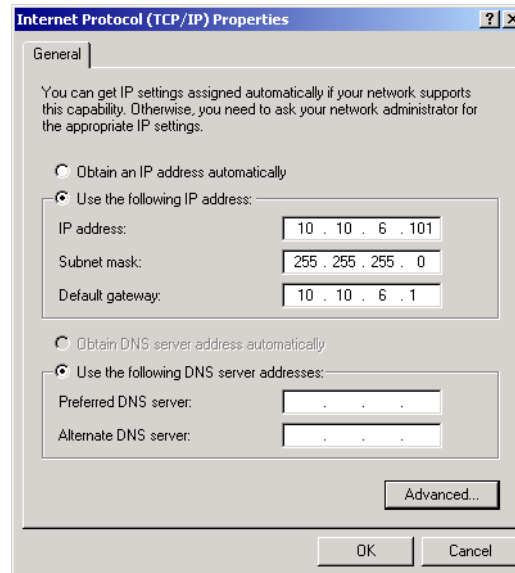

4. Click **<OK>** or **<Close>** to exit the various dialog boxes.

## E.3 Run a Program

You are now ready to run a sample program or develop a new application. Review these steps to check your Dynamic C RabbitSys setup before you run a program.

1. Set the compiler to run the application in the fast program execution SRAM by selecting **Code and BIOS in Flash, Run in RAM** from the Dynamic C **Options > Project Options > Compiler** menu.
2. Enable separate instruction and data spaces and select “Compile program in RabbitSys user mode” from the Dynamic C **Options > Project Options > Compiler** menu.
3. Enter the RCM3365 module’s IP address you used in Appendix E.1 by accessing the Dynamic C **Options > Project Options > Communications** menu to select “Use TCP/IP Connection.” You must also enter “32023” for the Control Port and the default login values of “admin” and “password.”

### E.3.1 Troubleshooting

- If you compiled and ran a sample program with the RabbitSys project option disabled, you may have overwritten the RabbitSys binary file. Use the serial programming cable to connect programming header J1 on the RCM3365 to your PC COM port to reload the RabbitSys binary file via the Dynamic C **Compile > Reload RabbitSys binary** menu.
- If you were unable to reload the RabbitSys binary file, your RCM3365 does not have the firmware to support Dynamic C RabbitSys and cannot be used with Dynamic C RabbitSys.
- If Dynamic C returns an error message, check that the RCM3365 is powered correctly — the red **CORE** LED on the Prototyping Board should be lit when the RCM3365 is mounted on the Prototyping Board and the AC adapter is plugged in. Ensure that the RCM3365 module is firmly and correctly installed in its connectors on the Prototyping Board.

**NOTE:** The rdiscover utility will not work when the RCM3365 is connected directly to a PC, notebook, or workstation via an Ethernet crossover cable unless the PC, notebook, or workstation is running a DHCP server.



# APPENDIX F. RABBITNET

## F.1 General RabbitNet Description

RabbitNet is a high-speed synchronous protocol developed by Rabbit to connect peripheral cards to a master and to allow them to communicate with each other.

### F.1.1 RabbitNet Connections

All RabbitNet connections are made point to point. A RabbitNet master port can only be connected directly to a peripheral card, and the number of peripheral cards is limited by the number of available RabbitNet ports on the master.

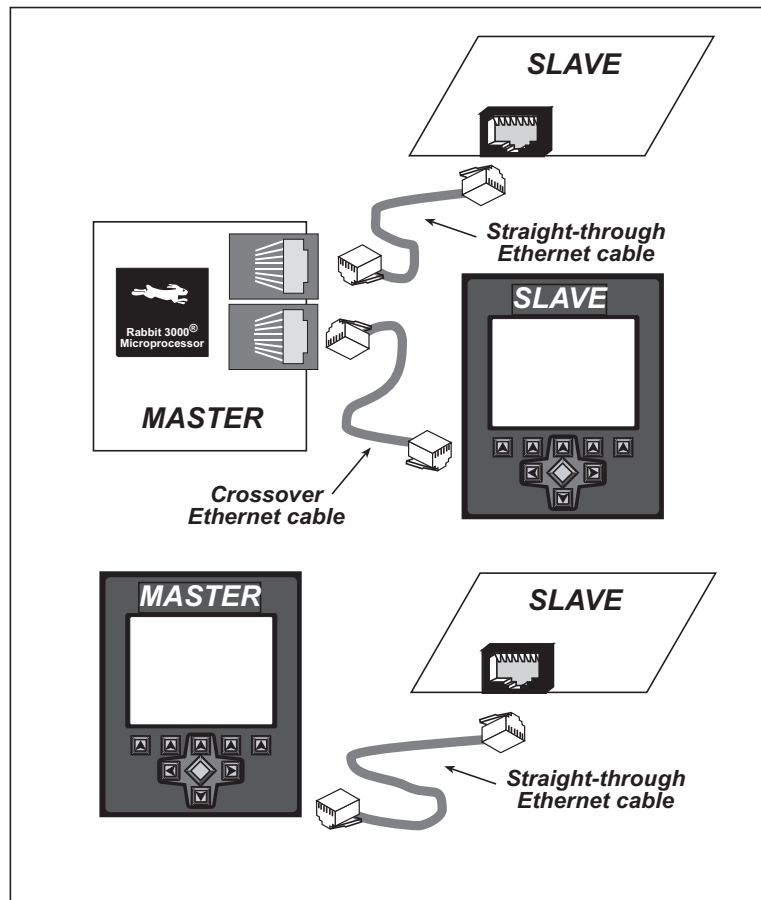

Figure F-1. Connecting Peripheral Cards to a Master

Use a straight-through Ethernet cable to connect the master to slave peripheral cards, unless you are using a device such as the OP7200 that could be used either as a master or a slave. In this case you would use a crossover cable to connect an OP7200 that is being used as a slave.

Distances between a master unit and peripheral cards can be up to 10 m or 33 ft.

### F.1.2 RabbitNet Peripheral Cards

- Digital I/O

24 inputs, 16 push/pull outputs, 4 channels of 10-bit A/D conversion with ranges of 0 to 10 V, 0 to 1 V, and -0.25 to +0.25 V. The following connectors are used:

Signal = 0.1" friction-lock connectors

Power = 0.156" friction-lock connectors

RabbitNet = RJ-45 connector

- A/D converter

8 channels of programmable-gain 12-bit A/D conversion, configurable as current measurement and differential-input pairs. 2.5 V reference voltage is available on the connector. The following connectors are used:

Signal = 0.1" friction-lock connectors

Power = 0.156" friction-lock connectors

RabbitNet = RJ-45 connector

- D/A converter

8 channels of 0–10 V 12-bit D/A conversion. The following connectors are used:

Signal = 0.1" friction-lock connectors

Power = 0.156" friction-lock connectors

RabbitNet = RJ-45 connector

- Display/Keypad interface

allows you to connect your own keypad with up to 64 keys and one character liquid crystal display from  $1 \times 8$  to  $4 \times 40$  characters with or without backlight using standard  $1 \times 16$  or  $2 \times 8$  connectors. The following connectors are used:

Signal = 0.1" headers or sockets

Power = 0.156" friction-lock connectors

RabbitNet = RJ-45 connector

- Relay card

6 relays rated at 250 V AC, 1200 V·A or 100 V DC up to 240 W. The following connectors are used:

Relay contacts = screw-terminal connectors

Power = 0.156" friction-lock connectors

RabbitNet = RJ-45 connector

Visit our [Web site](#) for up-to-date information about additional cards and features as they become available. The Web site also has the latest revision of this user's manual.

## F.2 Physical Implementation

There are four signaling functions associated with a RabbitNet connection. From the master's point of view, the transmit function carries information and commands to the peripheral card. The receive function is used to read back information sent to the master by the peripheral card. A clock is used to synchronize data going between the two devices at high speed. The master is the source of this clock. A slave select (SS) function originates at the master, and when detected by a peripheral card causes it to become selected and respond to commands received from the master.

The signals themselves are differential RS-422, which are series-terminated at the source. With this type of termination, the maximum frequency is limited by the round-trip delay time of the cable. Although a peripheral card could theoretically be up to 45 m (150 ft) from the master for a data rate of 1 MHz, Rabbit recommends a practical limit of 10 m (33 ft).

Connections between peripheral cards and masters are done using standard 8-conductor Ethernet cables. Masters and peripheral cards are equipped with RJ-45 8-pin female connectors. The cables may be swapped end for end without affecting functionality.

### F.2.1 Control and Routing

Control starts at the master when the master asserts the slave select signal (SS). Then it simultaneously sends a serial command and clock. The first byte of a command contains the address of the peripheral card if more than one peripheral card is connected.

A peripheral card assumes it is selected as soon as it receives the select signal. For direct master-to-peripheral-card connections, this is as soon as the master asserts the select signal. The connection is established once the select signal reaches the addressed slave. At this point communication between the master and the selected peripheral card is established, and data can flow in both directions simultaneously. The connection is maintained so long as the master asserts the select signal.

## F.3 Function Calls

The function calls described in this section are used with all RabbitNet peripheral cards, and are available in the `RNET.LIB` library in the Dynamic C `RABBITNET` folder.

```
int rn_init(char portflag, char servicetype);
```

Resets, initializes, or disables a specified RabbitNet port on the master single-board computer. During initialization, the network is enumerated and relevant tables are filled in. If the port is already initialized, calling this function forces a re-enumeration of all devices on that port.

Call this function first before using other RabbitNet functions.

### PARAMETERS

**portflag** is a bit that represents a RabbitNet port on the master single-board computer (from 0 to the maximum number of ports). A set bit requires a service. If **portflag** = 0x03, both RabbitNet ports 0 and 1 will need to be serviced.

**servicetype** enables or disables each RabbitNet port as set by the port flags.

0 = disable port

1 = enable port

### RETURN VALUE

0

```
int rn_device(char pna);
```

Returns an address index to device information from a given physical node address. This function will check device information to determine that the peripheral card is connected to a master.

### PARAMETER

**pna** is the physical node address, indicated as a byte.

7,6—2-bit binary representation of the port number on the master

5,4,3—Level 1 router downstream port

2,1,0—Level 2 router downstream port

### RETURN VALUE

Pointer to device information. -1 indicates that the peripheral card either cannot be identified or is not connected to the master.

### SEE ALSO

`rn_find`



```
int rn_find(rn_search *srch);
```

Locates the first active device that matches the search criteria.

#### PARAMETER

**srch** is the search criteria structure **rn\_search**:

```
unsigned int flags;    // status flags see MATCH macros below
unsigned int ports;   // port bitmask
char productid;      // product id
char productrev;     // product rev
char coderev;        // code rev
long serialnum;      // serial number
```

Use a maximum of 3 macros for the search criteria:

```
RN_MATCH_PORT        // match port bitmask
RN_MATCH_PNA         // match physical node address
RN_MATCH_HANDLE      // match instance (reg 3)
RN_MATCH_PRDID       // match id/version (reg 1)
RN_MATCH_PRDREV      // match product revision
RN_MATCH_CODEREV     // match code revision
RN_MATCH_SN          // match serial number
```

For example:

```
rn_search newdev;
newdev.flags = RN_MATCH_PORT|RN_MATCH_SN;
newdev.ports = 0x03; //search ports 0 and 1
newdev.serialnum = E3446C01L;
handle = rn_find(&newdev);
```

#### RETURN VALUE

Returns the handle of the first device matching the criteria. 0 indicates no such devices were found.

#### SEE ALSO

`rn_device`

```
int rn_echo(int handle, char sendecho,
            char *recdata);
```

The peripheral card sends back the character the master sent. This function will check device information to determine that the peripheral card is connected to a master.

#### PARAMETERS

**handle** is an address index to device information. Use `rn_device()` or `rn_find()` to establish the handle.

**sendecho** is the character to echo back.

**recdata** is a pointer to the return address of the character from the device.

#### RETURN VALUE

The status byte from the previous command. -1 means that device information indicates the peripheral card is not connected to the master.

```
int rn_write(int handle, int regno, char *data,  
int datalen);
```

Writes a string to the specified device and register. Waits for results. This function will check device information to determine that the peripheral card is connected to a master.

#### PARAMETERS

**handle** is an address index to device information. Use `rn_device()` or `rn_find()` to establish the handle.

**regno** is the command register number as designated by each device.

**data** is a pointer to the address of the string to write to the device.

**datalen** is the number of bytes to write (0–15).

**NOTE:** A data length of 0 will transmit the one-byte command register number.

#### RETURN VALUE

The status byte from the previous command. -1 means that device information indicates the peripheral card is not connected to the master, and -2 means that the data length was greater than 15.

#### SEE ALSO

`rn_read`

```
int rn_read(int handle, int regno, char *reccdata,  
int datalen);
```

Reads a string from the specified device and register. Waits for results. This function will check device information to determine that the peripheral card is connected to a master.

#### PARAMETERS

**handle** is an address index to device information. Use `rn_device()` or `rn_find()` to establish the handle.

**regno** is the command register number as designated by each device.

**reccdata** is a pointer to the address of the string to read from the device.

**datalen** is the number of bytes to read (0–15).

**NOTE:** A data length of 0 will transmit the one-byte command register number.

#### RETURN VALUE

The status byte from the previous command. -1 means that device information indicates the peripheral card is not connected to the master, and -2 means that the data length was greater than 15.

#### SEE ALSO

`rn_write`

```
int rn_reset(int handle, int resettype);
```

Sends a reset sequence to the specified peripheral card. The reset takes approximately 25 ms before the peripheral card will once again execute the application. Allow 1.5 seconds after the reset has completed before accessing the peripheral card. This function will check peripheral card information to determine that the peripheral card is connected to a master.

#### PARAMETERS

**handle** is an address index to device information. Use **rn\_device()** or **rn\_find()** to establish the handle.

**resettype** describes the type of reset.

0 = hard reset—equivalent to power-up. All logic is reset.

1 = soft reset—only the microprocessor logic is reset.

#### RETURN VALUE

The status byte from the previous command. -1 means that device information indicates the peripheral card is not connected to the master.

```
int rn_sw_wdt(int handle, float timeout);
```

Sets software watchdog timeout period. Call this function prior to enabling the software watchdog timer. This function will check device information to determine that the peripheral card is connected to a master.

#### PARAMETERS

**handle** is an address index to device information. Use **rn\_device()** or **rn\_find()** to establish the handle.

**timeout** is a timeout period from 0.025 to 6.375 seconds in increments of 0.025 seconds. Entering a zero value will disable the software watchdog timer.

#### RETURN VALUE

The status byte from the previous command. -1 means that device information indicates the peripheral card is not connected to the master.

```
int rn_enable_wdt(int handle, int wdtype);
```

Enables the hardware and/or software watchdog timers on a peripheral card. The software on the peripheral card will keep the hardware watchdog timer updated, but will hard reset if the time expires. The hardware watchdog cannot be disabled except by a hard reset on the peripheral card. The software watchdog timer must be updated by software on the master. The peripheral card will soft reset if the timeout set by `rn_sw_wdt()` expires. This function will check device information to determine that the peripheral card is connected to a master.

#### PARAMETERS

**handle** is an address index to device information. Use `rn_device()` or `rn_find()` to establish the handle.

**wdtype**

0 enables both hardware and software watchdog timers

1 enables hardware watchdog timer

2 enables software watchdog timer

#### RETURN VALUE

The status byte from the previous command. -1 means that device information indicates the peripheral card is not connected to the master.

#### SEE ALSO

`rn_hitwd`, `rn_sw_wdt`

```
int rn_hitwd(int handle, char *count);
```

Hits software watchdog. Set the timeout period and enable the software watchdog prior to using this function. This function will check device information to determine that the peripheral card is connected to a master.

#### PARAMETERS

**handle** is an address index to device information. Use `rn_device()` or `rn_find()` to establish the handle.

**count** is a pointer to return the present count of the software watchdog timer. The equivalent time left in seconds can be determined from `count × 0.025` seconds.

#### RETURN VALUE

The status byte from the previous command. -1 means that device information indicates the peripheral card is not connected to the master.

#### SEE ALSO

`rn_enable_wdt`, `rn_sw_wdt`

```
int rn_rst_status(int handle, char *retdata);
```

Reads the status of which reset occurred and whether any watchdogs are enabled.

#### PARAMETERS

**handle** is an address index to device information. Use `rn_device()` or `rn_find()` to establish the handle.

**retdata** is a pointer to the return address of the communication byte. A set bit indicates which error occurred. This register is cleared when read.

- 7—HW reset has occurred
- 6—SW reset has occurred
- 5—HW watchdog enabled
- 4—SW watchdog enabled
- 3,2,1,0—Reserved

#### RETURN VALUE

The status byte from the previous command.

```
int rn_comm_status(int handle, char *retdata);
```

#### PARAMETERS

**handle** is an address index to device information. Use `rn_device()` or `rn_find()` to establish the handle.

**retdata** is a pointer to the return address of the communication byte. A set bit indicates which error occurred. This register is cleared when read.

- 7—Data available and waiting to be processed MOSI (master out, slave in)
- 6—Write collision MISO (master in, slave out)
- 5—Overrun MOSI (master out, slave in)
- 4—Mode fault, device detected hardware fault
- 3—Data compare error detected by device
- 2,1,0—Reserved

#### RETURN VALUE

The status byte from the previous command.

### F.3.1 Status Byte

Unless otherwise specified, functions returning a status byte will have the following format for each designated bit.

7	6	5	4	3	2	1	0	
×	×							00 = Reserved 01 = Ready 10 = Busy 11 = Device not connected
		×						0 = Device 1 = Router
			×					0 = No error 1 = Communication error <sup>*</sup>
				×				Reserved for individual peripheral cards
					×			Reserved for individual peripheral cards
						×		0 = Last command accepted 1 = Last command unexecuted
							×	0 = Not expired 1 = HW or SW watchdog timer expired <sup>†</sup>

\* Use the function `rn_comm_status()` to determine which error occurred.

† Use the function `rn_rst_status()` to determine which timer expired.

# INDEX

## Symbols

/IOWR  
loading ..... 32

## A

accessories  
  Connector Adapter Board ... 7  
  USB Removable Memory  
    Card Reader ..... 7  
additional information  
  online documentation ..... 7

## B

battery backup  
  circuit ..... 134  
  external battery connections ..... 133  
  reset generator ..... 135  
  use of battery-backed SRAM  
    ..... 44  
board initialization  
  function calls ..... 46  
  brdInit ..... 46  
bus loading ..... 73

## C

clock doubler ..... 40  
conformal coating ..... 79, 80  
Connector Adapter Board ..... 7

## D

Development Kit  
  RabbitSys Development Kit 7  
  RCM3365/RCM3375 ..... 6  
  32 MB NAND flash ..... 6  
  AC adapter ..... 6  
  DC power supply ..... 6  
  Getting Started instructions ..... 6  
  programming cable ..... 6

digital I/O ..... 28  
  function calls  
    digIn ..... 47  
    digOut ..... 47  
  I/O buffer sourcing and sinking limits ..... 77  
  memory interface ..... 33  
  SMODE0 ..... 35  
  SMODE1 ..... 35

digital inputs  
  switching threshold ..... 90

dimensions  
  LCD/keypad module ..... 103  
  LCD/keypad template ..... 106  
  Prototyping Board ..... 85  
  RCM3365/RCM3375 ..... 68  
Dynamic C ..... 7, 9, 14, 41  
  add-on modules ..... 9, 52  
  installation ..... 9  
  battery-backed SRAM ..... 44  
  FAT file system ..... 45  
libraries  
  RCM33xx.LIB ..... 46  
  RN\_CFG\_RCM33.LIB ..... 46  
protected variables ..... 44  
Rabbit Embedded Security  
  Pack ..... 7, 9, 52  
sample programs ..... 20  
standard features  
  debugging ..... 42  
telephone-based technical  
  support ..... 7, 52  
upgrades and patches ..... 52  
USB/serial port converter ..... 15

## E

Ethernet cables ..... 53  
  how to tell them apart ..... 53  
Ethernet connections ..... 53, 55  
  10/100Base-T ..... 55  
  10Base-T Ethernet card ..... 53  
  additional resources ..... 65

  direct connection ..... 55  
  Ethernet cables ..... 55  
  Ethernet hub ..... 53  
  IP addresses ..... 55, 57  
  MAC addresses ..... 58  
  steps ..... 54  
Ethernet port ..... 34  
  pinout ..... 34  
exclusion zone ..... 69  
external I/O bus ..... 33  
  software ..... 33, 44, 113

## F

features ..... 2  
  comparison with RCM3305/  
    RCM3315 ..... 4  
  Prototyping Board ..... 82, 83  
flash memory addresses  
  user blocks ..... 38

## H

hardware connections  
  install RCM3365/RCM3375  
    on Prototyping Board ... 10  
  power supply ..... 13  
  programming cable ..... 11  
hardware reset ..... 13  
headers  
  Prototyping Board  
    JP3 ..... 92  
    JP5 ..... 95

## I

I/O address assignments  
  LCD/keypad module ..... 107  
I/O buffer sourcing and sinking  
  limits ..... 77  
IP addresses ..... 57  
  how to set in sample programs  
    ..... 62  
  how to set PC IP address .. 63

## J

jumper configurations	
Prototyping Board	
JP1 (stepper motor power supply) .....	99
JP2 (stepper motor power supply) .....	99
JP3 (quadrature decoder/serial flash) .....	99
JP4 (RCM3365/RCM3375 power supply) .....	99
JP5 (RS-485 bias and termination resistors) ....	95, 99
stepper motor power supply .....	97
RCM3365/RCM3375 ..	78, 79
JP2 (flash memory bank select) .....	79
JP3 (data SRAM size) ...	79
JP4 (Ethernet or I/O output on header J3) .....	79
JP5 (Ethernet or I/O output on header J3) .....	79
JP6 (Ethernet or I/O output on header J3) .....	79
JP7 (Ethernet or I/O output on header J3) .....	79
JP8 (Ethernet or I/O output on header J3) .....	79
JP9 (chip select signals for NAND flash and xD-Picture Card) .....	79
jumper locations .....	78
R96 (xD-Picture Card detect) .....	79

## K

keypad template .....	106
removing and inserting label .....	106

## L

LCD/keypad module	
bezel-mount installation ..	109
dimensions .....	103
function calls	
dispInit .....	113
header pinout .....	107
I/O address assignments ..	107

## keypad

function calls	
keyConfig .....	130
keyGet .....	131
keyInit .....	130
keypadDef .....	132
keyProcess .....	131
keyScan .....	132
keyUnget .....	131
keypad template .....	106
LCD display	

function calls	
glBackLight .....	114
glBlankScreen .....	115
glBlock .....	115
glBuffLock .....	121
glBuffUnlock .....	121
glDispOnOff .....	114
glDown1 .....	124
glFillCircle .....	118
glFillPolygon .....	117
glFillScreen .....	115
glFillVPolygon .....	117
glFontCharAddr .....	119
glGetBrushType .....	122
glGetPfsStep .....	120
glHScroll .....	125
glInit .....	114
glLeft1 .....	123
glPlotCircle .....	117
glPlotDot .....	122
glPlotLine .....	123
glPlotPolygon .....	116
glPlotVPolygon .....	116
glPrintf .....	121
glPutChar .....	120
glPutFont .....	119
glRight1 .....	123
glSetBrushType .....	122
glSetContrast .....	115
glSetPfsStep .....	119
glSwap .....	122
glUp1 .....	124
glVScroll .....	126
glXFontInit .....	118
glXPutBitmap .....	126
glXPutFastmap .....	127
TextCursorLocation ..	128
TextGotoXY .....	128
TextPrintf .....	129
TextPutChar .....	129
TextWindowFrame ..	127

## LEDs

function calls .....	113
displedOut .....	113
mounting instructions .....	108
reconfigure keypad .....	106
remote cable connection ..	111
removing and inserting keypad label .....	106
sample programs .....	112
specifications .....	104
versions .....	103
voltage settings .....	105

## LED (Prototyping Board)

function calls	
ledOut .....	48
LEDs (RCM3365/RCM3375)	33
ACT .....	33
FM .....	33
LINK .....	33
SPEED .....	33
USR .....	33

## M

MAC addresses .....	58
mounting instructions	
LCD/keypad module .....	108

## P

peripheral cards	
connection to master	143, 144
pinout	
Ethernet port .....	34
LCD/keypad module .....	107
RCM3365/RCM3375	
alternate configurations	30
RCM3365/RCM3375 headers .....	28
power supplies	
+3.3 V .....	133
battery backup .....	133
Program Mode .....	36
switching modes .....	36
programming cable	
PROG connector .....	36
RCM3365/RCM3375 connections .....	11
programming option	
Ethernet crossover cable	137
troubleshooting .....	141
programming port .....	35



Prototyping Board .....	82	RabbitSys .....	43	NAND flash	
adding components .....	89	check whether RCM3365 has		NFLASH_DUMP.c .....	21
dimensions .....	85	RabbitSys firmware 17, 141		NFLASH_ERASE.c .....	22
expansion area .....	83	Dynamic C setup .....	16, 141	NFLASH_INSPECT.c ..	21
features .....	82, 83	troubleshooting .....	17	NFLASH_LOG.C .....	21
jumper configurations .....	99	RCM3309/RCM3319		PONG.C .....	15, 16
jumper locations .....	98	comparison with RCM3305/		RabbitNet .....	26
mounting RCM3365/		RCM3315 .....	4	real-time clock	
RCM3375 .....	10	RCM3365/RCM3375		RTC_TEST.C .....	25
power supply .....	87	mounting on Prototyping		SETRTCKB.C .....	25
prototyping area .....	89	Board .....	10	serial communication	
specifications .....	86	relay		FLOWCONTROL.C .....	24
use of parallel ports .....	100	function calls		PARITY.C .....	24
<b>R</b>		relayOut .....	49	SIMPLE3WIRE.C .....	24
Rabbit 3000		remote programming .....	43	SIMPLE485MASTER.C	25
data and clock delays .....	75	download manager .....	43	SIMPLE485SLAVE.C ..	25
spectrum spreader time delays		RabbitLink .....	43	SIMPLE5WIRE.C .....	24
.....	75	RabbitSys .....	43	SWITCHCHAR.C .....	25
Rabbit subsystems .....	29	reset .....	13	SETUPFORCROSSOVER.C	
RabbitNet		use of reset pin .....	135	.....	138
Ethernet cables to connect		RS-485 network		TCP/IP	
peripheral cards ..	143, 144	termination and bias resistors		BROWSELED.C .....	64
function calls		.....	95	DISPLAY_MAC.C .....	58
m_comm_status .....	151	Run Mode .....	36	MBOXDEMO.C .....	64
m_device .....	146	switching modes .....	36	PINGLED.C .....	65
m_echo .....	147	<b>S</b>		PINGME.C .....	64
m_enable_wdt .....	150	sample programs .....	20	RabbitWeb	
m_find .....	147	download manager		BLINKLEDS.C .....	65
m_hitwd .....	150	DLM_TCP.C .....	43	DOORMONITOR.C .	65
m_init .....	146	DLP_TCP.C .....	43	SPRINKLER.C .....	65
m_read .....	148	getting to know the		SMTP.C .....	65
m_reset .....	149	RCM3365/RCM3375		user-programmable LED	
m_rst_status .....	151	CONTROLLED.C .....	20	FLASHLED.C .....	33
m_sw_wdt .....	149	FLASHLED1.C .....	20	serial communication .....	34
m_write .....	148	SWRELAY.C .....	20	function calls	
general description .....	143	TOGGLESWITCH.C ..	20	ser485Rx .....	49
peripheral cards .....	144	hot-swapping xD-Picture Card		ser485Tx .....	49
A/D converter .....	144	FAT_HOT_SWAP.c .....	23	Prototyping Board	
D/A converter .....	144	FAT_HOT_SWAP_3365_		RS-232 .....	93
digital I/O .....	144	75.c .....	23	RS-485 termination and bias	
display/keypad interface		FAT_HOT_SWAP_		resistors .....	95
.....	144	336x0.c .....	39	serial port configura-	
relay card .....	144	how to run TCP/IP sample		tions .....	92
physical implementation .	145	programs .....	61, 62	RabbitNet port .....	95
RabbitNet port .....	95	how to set IP address .....	62	serial ports .....	34
RabbitNet port		how to use non-RCM3365/		Ethernet port .....	34
function calls .....	50	RCM3375 RabbitNet		programming port .....	35
macros .....	50	sample programs .....	26	Prototyping Board .....	92
m_sp_close .....	51	LCD/keypad module .	26, 112		
m_sp_disable .....	51	KEYBASIC.C .....	106		
m_sp_enable .....	51	KEYPADTOLED.C .....	112		
m_sp_info .....	50	LCDKEYFUN.C .....	112		
		reconfigure keypad .....	106		
		SWITCHTOLCD.C .....	112		

software .....	7
external I/O bus .....	44
I/O drivers .....	44
libraries	
LCD122KEY7.LIB .....	113
NAND flash .....	45
PACKET.LIB .....	45
RCM33XX.LIB .....	46
RN_CFG_RCM33.LIB .....	46
RNET.LIB .....	146
RS232.LIB .....	45
TCP/IP .....	45
NAND flash drivers .....	45
serial communication drivers	
.....	45
TCP/IP drivers .....	45
specifications .....	67
bus loading .....	73
digital I/O buffer sourcing and	
sinking limits .....	77
dimensions .....	68
electrical, mechanical, and	
environmental .....	70
exclusion zone .....	69
header footprint .....	72
headers .....	72
LCD/keypad module	
dimensions .....	103
electrical .....	104
header footprint .....	104
mechanical .....	104
relative pin 1 locations	104
temperature .....	104
Prototyping Board .....	86
Rabbit 3000 DC characteris-	
tics .....	76
Rabbit 3000 timing diagram	
.....	74
relative pin 1 locations .....	72
spectrum spreader .....	75
settings .....	40
status byte .....	152
subsystems	
digital inputs and outputs .....	28
switches	
function calls	
switchIn .....	48
switching modes .....	36

## T

TCP/IP primer .....	55
load TCP/IP parameters to PC	
.....	139
RabbitSys	
load TCP/IP parameters to	
RCM3365 .....	138
technical support .....	17
troubleshooting	
changing COM port .....	15
connections .....	15
programming via Ethernet	
crossover cable .....	141
programming via serial cable	
.....	15
programming via straight-	
through Ethernet cable .....	17
RabbitSys .....	17

## U

USB/serial port converter .....	11
Dynamic C settings .....	15
user block	
function calls	
readUserBlock .....	38
writeUserBlock .....	38

## X

xD-Picture Card	
formatting .....	45
USB Removable Memory	
Card Reader .....	7
use in mass-storage applica-	
tion .....	45



# SCHEMATICS

## **090-0214 RCM3365/RCM3375 Schematic**

[www.rabbit.com/documentation/schemat/090-0214.pdf](http://www.rabbit.com/documentation/schemat/090-0214.pdf)

## **090-0188 Prototyping Board Schematic**

[www.rabbit.com/documentation/schemat/090-0188.pdf](http://www.rabbit.com/documentation/schemat/090-0188.pdf)

## **090-0156 LCD/Keypad Module Schematic**

[www.rabbit.com/documentation/schemat/090-0156.pdf](http://www.rabbit.com/documentation/schemat/090-0156.pdf)

## **090-0128 Serial Programming Cable Schematic**

[www.rabbitsemiconductor.com/documentation/schemat/090-0128.pdf](http://www.rabbitsemiconductor.com/documentation/schemat/090-0128.pdf)

You may use the URL information provided above to access the latest schematics directly.





## Стандарт Электрон Связь

Мы молодая и активно развивающаяся компания в области поставок электронных компонентов. Мы поставляем электронные компоненты отечественного и импортного производства напрямую от производителей и с крупнейших складов мира.

Благодаря сотрудничеству с мировыми поставщиками мы осуществляем комплексные и плановые поставки широчайшего спектра электронных компонентов.

Собственная эффективная логистика и склад в обеспечивает надежную поставку продукции в точно указанные сроки по всей России.

Мы осуществляем техническую поддержку нашим клиентам и предпродажную проверку качества продукции. На все поставляемые продукты мы предоставляем гарантию .

Осуществляем поставки продукции под контролем ВП МО РФ на предприятия военно-промышленного комплекса России , а также работаем в рамках 275 ФЗ с открытием отдельных счетов в уполномоченном банке. Система менеджмента качества компании соответствует требованиям ГОСТ ISO 9001.

Минимальные сроки поставки, гибкие цены, неограниченный ассортимент и индивидуальный подход к клиентам являются основой для выстраивания долгосрочного и эффективного сотрудничества с предприятиями радиоэлектронной промышленности, предприятиями ВПК и научно-исследовательскими институтами России.

С нами вы становитесь еще успешнее!

### Наши контакты:

**Телефон:** +7 812 627 14 35

**Электронная почта:** [sales@st-electron.ru](mailto:sales@st-electron.ru)

**Адрес:** 198099, Санкт-Петербург,  
Промышленная ул, дом № 19, литера Н,  
помещение 100-Н Офис 331