

LTC3880EUJ

Programming Board for Dual-/Two-Phase DC/DC Controller with Digital Power Management

DESCRIPTION

Demonstration circuit 1709A contains the circuitry needed to program and verify the EEPROM within the LTC[®]3880 and LTC3880-1. That is its only purpose. The DC1709A is shipped with a LTC3880 installed in the clamshell style programming socket. The EEPROM contains the factory default configuration. The LTpowerPlay™ .proj file that corresponds to the factory default can be found in the GUI.

In order to properly verify the contents of the EEPROM, download and install the LTpowerPlay software (GUI). The software can be downloaded from:

<http://www.linear.com/ltpowerplay>

You also need a Linear Technology USB to I²C/SMBus/PMBus Controller, DC1613A or DC1427A.

DEMO SYSTEM REQUIRED HARDWARE

- Windows PC
- USB to I²C/SMBus/PMBus Controller, DC1613A or DC1427A
- DC1709A

DEMO SYSTEM REQUIRED SOFTWARE

- LTpowerPlay

LTC3880 FEATURES

- PMBus/I²C compliant serial interface
- Telemetry readback includes V_{IN} , I_{IN} , V_{OUT} , I_{OUT} , temperature and faults
- Programmable voltage, current limit, digital soft-start/stop, sequencing, margining, OV/UV and frequency synchronization (250kHz to 1MHz)
- $\pm 0.5\%$ output voltage accuracy over temperature
- Integrated 16-bit ADC
- Internal EEPROM and fault logging
- Integrated powerful N-channel MOSFET gate drivers
- Wide V_{IN} range: 4.5V to 24V
- V_{OUT} range: 0.5V to 5.5V
- Supports power-up into prebiased load
- Analog current mode control loop
- Accurate PolyPhase[®] current sharing
- Available in a 40-pin (6mm × 6mm) QFN package

Design files for this circuit board are available at <http://www.linear.com/demo>

LT, LT, LTC, LTM, Linear Technology, the Linear logo and PolyPhase are registered trademarks and LTpowerPlay is a trademark of Linear Technology Corporation. All other trademarks are the property of their respective owners.

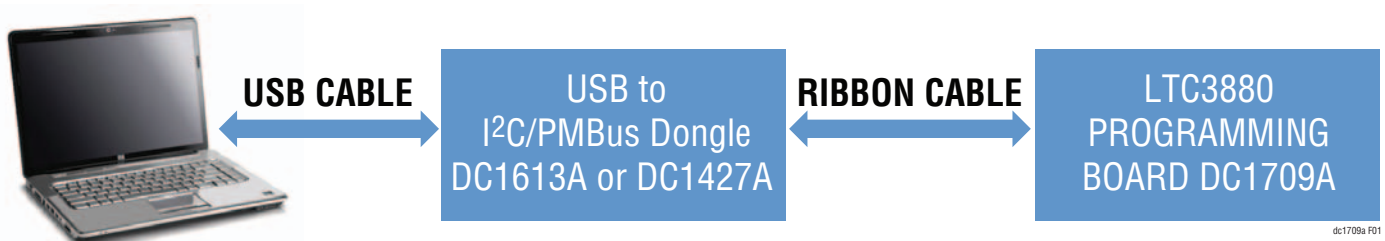

Figure 1. LTC3880 Programming Setup Using the DC1709A

QUICK START PROCEDURE

Demonstration circuit 1709A makes it easy to program and verify the EEPROM contents of the LTC3880.

1. Make sure jumpers are in the following positions:

JUMPER	POSITION	FUNCTION
JP1	Off	Write Protection of LTC3880
JP2	On	Write Protection of Identification EEPROM

2. Open the lid of the socket, SKT1. Verify there is an IC inside (see Figure 2).

3. Close the lid. It will snap into place.

NOTE: Removal and insertion of the IC should be done with either a tweezers or a vacuum suction device.

4. Plug one end of the USB cable to your PC. Plug the other end of the USB cable into the I²C/SMBus/PMBus controller.

5. If you have a DC1427A, plug the ribbon cable into J1 (see Figure 3). If you have a DC1613A, plug the ribbon cable into J2, as shown in Figure 3 and Figure 4.

6. On your PC, launch LTpowerPlay. LTpowerPlay will identify the DC1709A and launch the appropriate GUI (see Figure 5).

NOTE: You will see an undertemperature (UT) fault. This is normal since the temperature sensing pin is grounded. Ignore this fault at the moment.

7. Change the GUI parameters according to your system requirements. Or, you can open an existing project file by clicking this button:



8. After you finish the design, save the project file by clicking this button:



POWERING DOWN THE BOARD BETWEEN PROGRAMMING OPERATIONS

Disconnect the USB cable from the DC1427A/DC1613A before removing or inserting a LTC3880 into the programming socket.

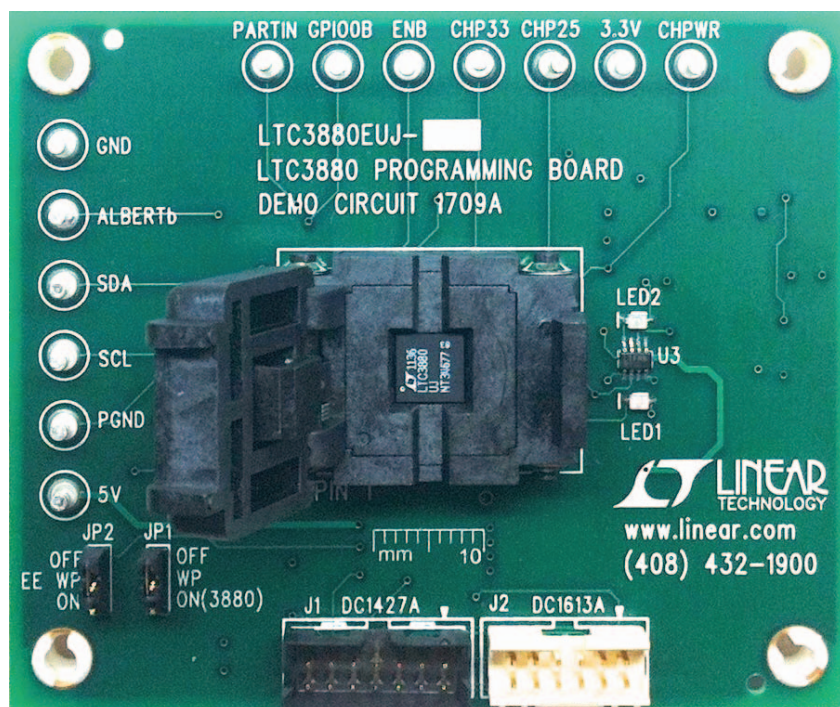

Figure 2. Open Shell. Verify IC Installed

QUICK START PROCEDURE

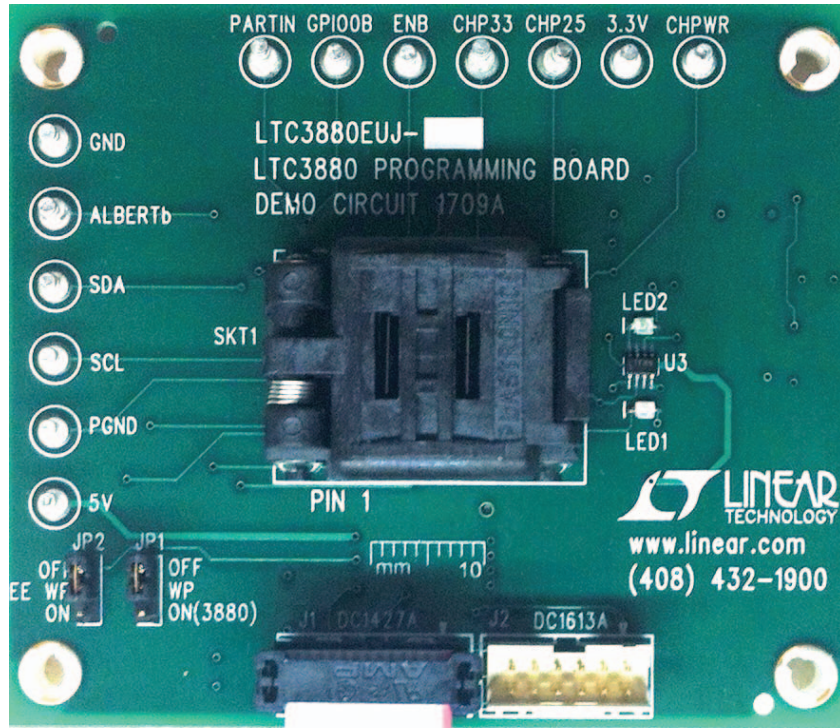

Figure 3. FDC1427A Ribbon Cable Installation

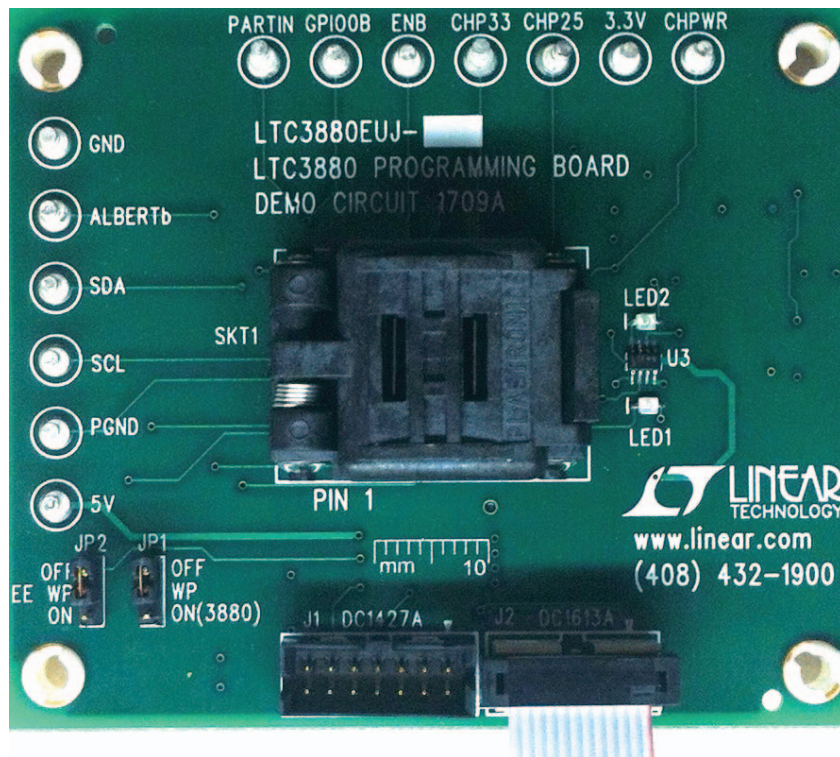

Figure 4. DC1613A Ribbon Cable Installation

DEMO MANUAL DC1709A

QUICK START PROCEDURE

WHAT YOU CAN DO WITH THE DC1709A

1. Compare the contents of the EEPROM in the LTC3880 against your project or hex file.
2. Reprogram the contents of the EEPROM in the LTC3880 using your project or hex file.

3. Verify the EEPROM within the DC1709A contains the factory defaults.

- From the LTpowerPlay interface, load the factory defaults project file. This file is located at:

C:\Program Files\Linear Technology\LTpowerPlay\project files\democircuits\LTC3880_datasheet_defaults.proj

- Click the Verify button.

Design files for this circuit board are available at

<http://www.linear.com/demo>

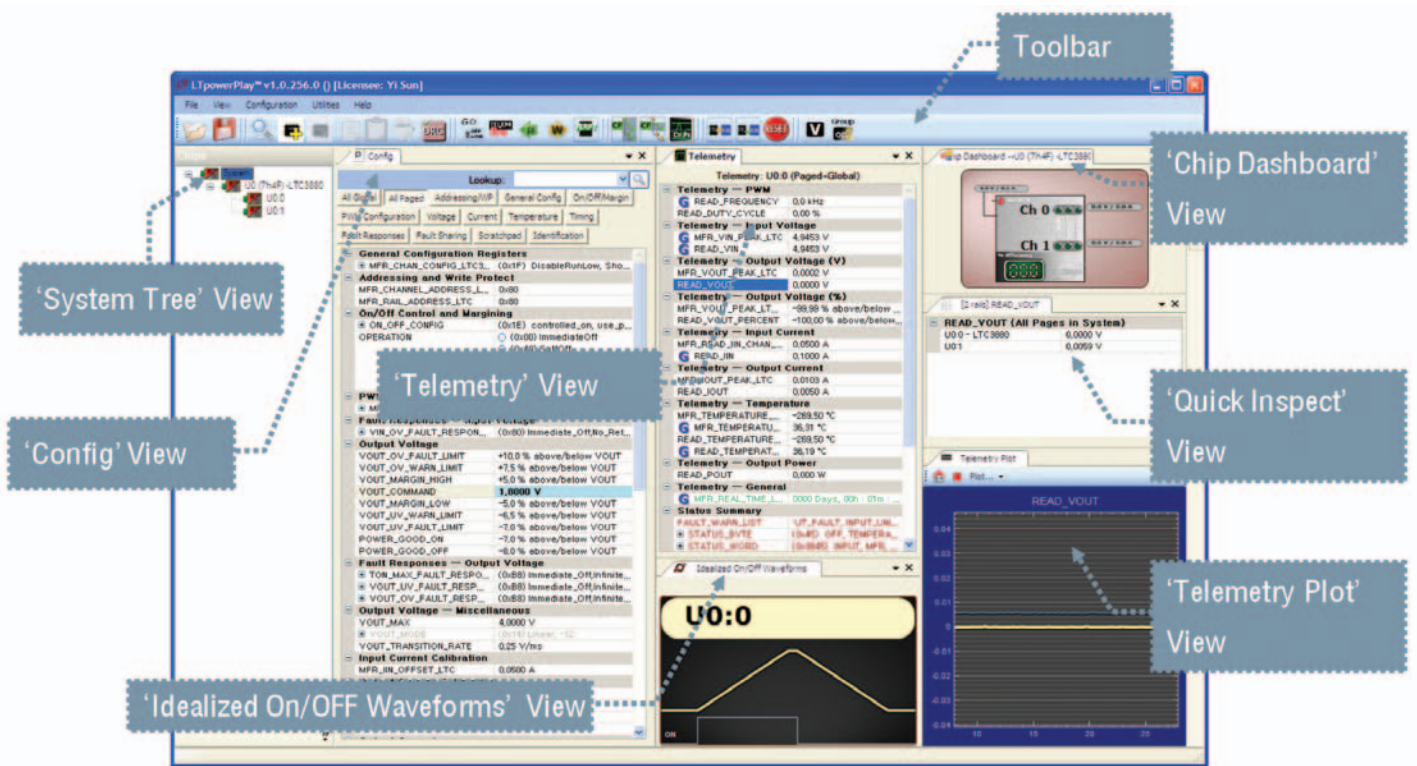

Figure 5. LTpowerPlay Interface of Programming the LTC3880

PARTS LIST

ITEM	QTY	REFERENCE	PART DESCRIPTION	MANUFACTURER/PART NUMBER
Required Circuit Components				
1	1	SKT1	6×6 QFN FLAT LEAD LIDDED THROUGH-HOLE SOCKET	PLASTRONICS, 40QN50S16060-B
2	4	C11, C14, C16, C20	CAP., 0.10µF, 10%, 16V, X7R, 0603	AVX, 0603YC104KAT2A
3	0	C12	CAP., CER, 10000pF, 25V, 10%, X7R, 0603, OPT.	AVX, 06033C103KAT2A
4	1	C13	CAP., 1µF, 16V, CERAMIC, X7R, 1206	AVX, 1206YZ105KAT
5	2	C15, C17	CAP., 4.7µF, 6.3V, CERAMIC, X5R, 1206	TDK, C3216X5R0J475K
6	4	C18, C19	CAP., TANTALUM, 1µF, 50V, 10%, SMD	AVX, TAJC105K050RNJ
7	1	LED1	LED, RED S-TYPE GULL WING, 2.03V, SMD	PANASONIC, LN1271RTR
8	1	LED2	LED, GREEN S-TYPE GULL WING 2.03V, SMD	PANASONIC, LN1371SGTRP
9	3	Q1, Q2, Q3	MOSFET P-CH, 20V, 580mA, SOT23-3	VISHAY, TP0101K-T1-E3
10	1	Q4	MOSFET N-CH, 60V, 115mA, SOT-23	FAIRCHILD SEMICONDUCTOR, 2N7002
11	1	Q5	MOSFET, N-CH, 30V, 5.1A, SC70-6	VISHAY, Si1470DH-T1-E3
12	3	R19, R21, R28	RES., 1.00kΩ, 1/8W, 1%, 0805, SMD	VISHAY, CRCW08051K00FKEA
13	8	R20, R23-R26, R29, R31, R33	RES., 10.0kΩ, 1/10W, 1%, 0805, SM	YAGEO, RC0805FR-0710KL
14	1	R22	RES., 100kΩ, 1/8W, 1%, 0805, SMD	YAGEO, RC0805FR-07100KL
15	1	R27	RES., 0.50Ω, 1/3W, 1%, 0805, SMD	SUSUMU, RL1220S-R50-F
16	3	R30, R34, R39	RES., 1.0Ω, 1/8W, 1%, 0805, SMD	YAGEO, RC0805FR-071RL
17	0	R32, R38	RES., 1.0Ω, 1/8W, 1%, 0805, SMD, OPT.	
18	3	R35, R36, R37	RES., 4.99kΩ, 1/8W, 1%, 0805, SMD	YAGEO, RC0805FR-074K99L
19	1	U3	IC., OVERVOLTAGE/OVERCURRENT PROTECTION CONTROLLER	LINEAR TECHNOLOGY, LTC4361CTS8-2#PBF
20	1	U2	IC., EEPROM, 2KBIT, 400kHz, 8SOIC	MICROCHIP, 24LC025-I/SN
21	2	JP1, JP2	HEADER, 0.079, SINGLE ROW, 3-PIN	SAMTEC, TMM-103-02-L-S
22	1	J1	CONN, HEADER, 14POS, 2mm, VERT GOLD	MOLEX, 87831-1420
23	1	J2	CONN, HEADER, 12POS, 2mm, 2ROW GOLD	FCI CONNECTOR CORP., 98414-G06-12ULF
24	13	TP1,TP2,TP3,TP4,TP5,TP6,TP7, TP8,TP9,TP10,TP11,TP13	TURRET, TERM SOLDER, 0.156", 0.066"L	MILL-MAX, 2501-2-00-80-00-00-07-0
25	4	MTH1, MTH2, MTH3, MTH4	SUPPORT POST NYLON SNAP-IN, 1/4"	KEYSTONE, 8831
26	2	JP1, JP2	SHUNT	SAMTEC, 2SN-BK-G
27	1		STENCIL, TOP	STENCIL, DC1709A
28	1		FAB, PRINTED CIRCUIT BOARD	DEMO CIRCUIT, 1709A

SCHEMATIC DIAGRAM

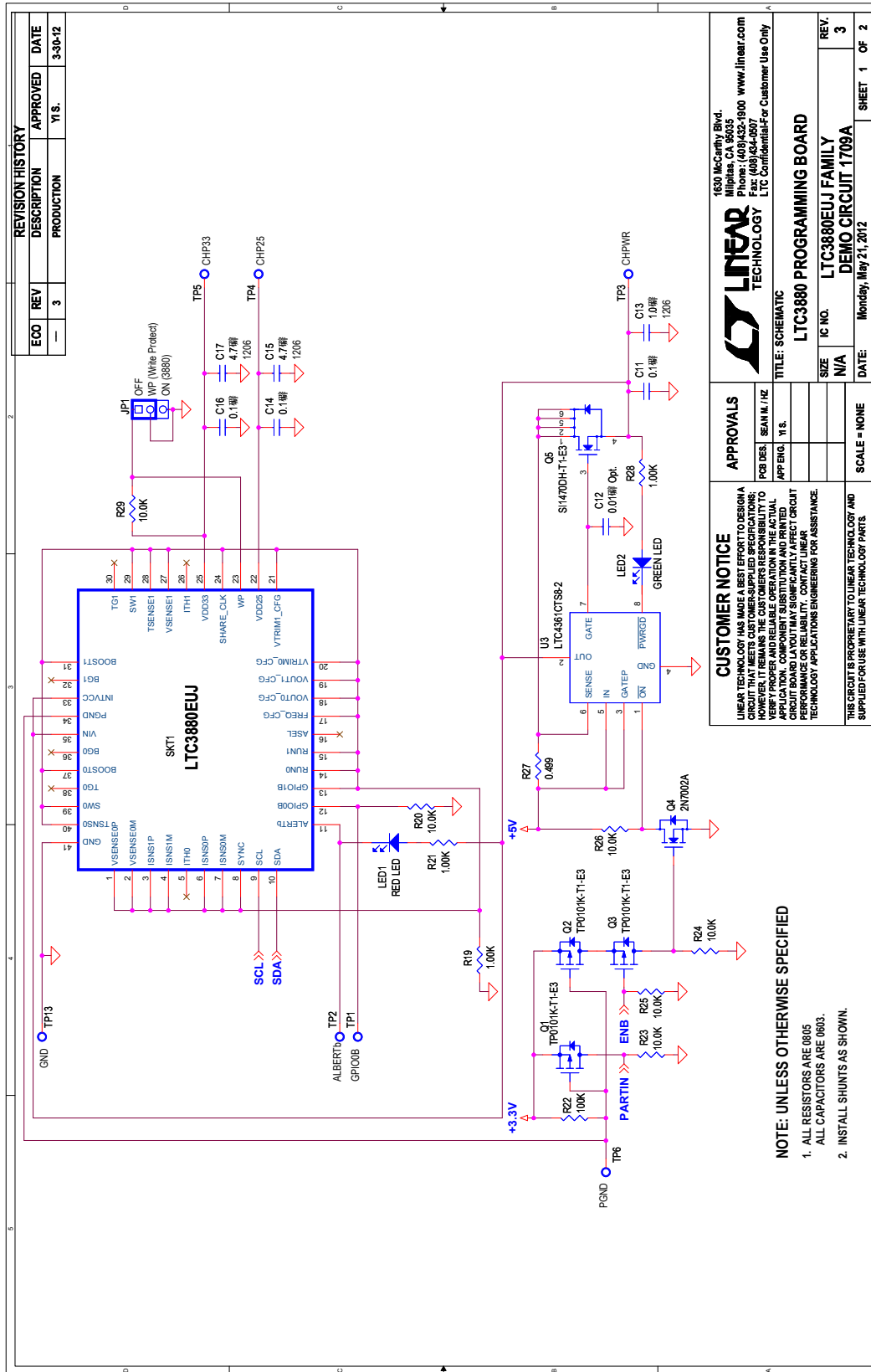

Figure 6. LTC3880 Programming Board

SCHEMATIC DIAGRAM

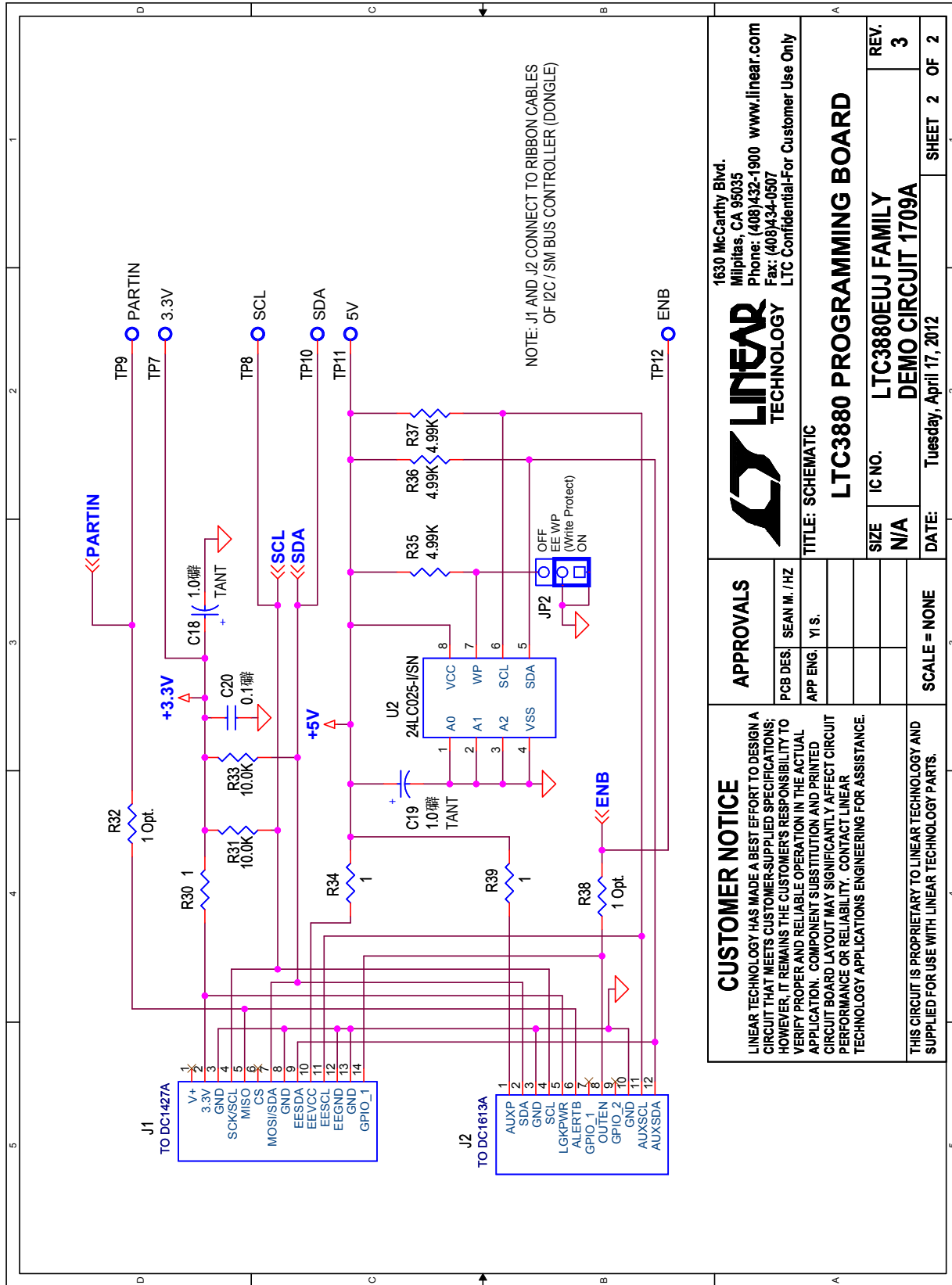

Figure 7. LTC3880 Programming Board

DEMO MANUAL DC1709A

DEMONSTRATION BOARD IMPORTANT NOTICE

Linear Technology Corporation (LTC) provides the enclosed product(s) under the following **AS IS** conditions:

This demonstration board (DEMO BOARD) kit being sold or provided by Linear Technology is intended for use for **ENGINEERING DEVELOPMENT OR EVALUATION PURPOSES ONLY** and is not provided by LTC for commercial use. As such, the DEMO BOARD herein may not be complete in terms of required design-, marketing-, and/or manufacturing-related protective considerations, including but not limited to product safety measures typically found in finished commercial goods. As a prototype, this product does not fall within the scope of the European Union directive on electromagnetic compatibility and therefore may or may not meet the technical requirements of the directive, or other regulations.

If this evaluation kit does not meet the specifications recited in the DEMO BOARD manual the kit may be returned within 30 days from the date of delivery for a full refund. **THE FOREGOING WARRANTY IS THE EXCLUSIVE WARRANTY MADE BY THE SELLER TO BUYER AND IS IN LIEU OF ALL OTHER WARRANTIES, EXPRESSED, IMPLIED, OR STATUTORY, INCLUDING ANY WARRANTY OF MERCHANTABILITY OR FITNESS FOR ANY PARTICULAR PURPOSE. EXCEPT TO THE EXTENT OF THIS INDEMNITY, NEITHER PARTY SHALL BE LIABLE TO THE OTHER FOR ANY INDIRECT, SPECIAL, INCIDENTAL, OR CONSEQUENTIAL DAMAGES.**

The user assumes all responsibility and liability for proper and safe handling of the goods. Further, the user releases LTC from all claims arising from the handling or use of the goods. Due to the open construction of the product, it is the user's responsibility to take any and all appropriate precautions with regard to electrostatic discharge. Also be aware that the products herein may not be regulatory compliant or agency certified (FCC, UL, CE, etc.).

No License is granted under any patent right or other intellectual property whatsoever. **LTC assumes no liability for applications assistance, customer product design, software performance, or infringement of patents or any other intellectual property rights of any kind.**

LTC currently services a variety of customers for products around the world, and therefore this transaction **is not exclusive**.

Please read the DEMO BOARD manual prior to handling the product. Persons handling this product must have electronics training and observe good laboratory practice standards. **Common sense is encouraged.**

This notice contains important safety information about temperatures and voltages. For further safety concerns, please contact a LTC application engineer.

Mailing Address:

Linear Technology
1630 McCarthy Blvd.
Milpitas, CA 95035

Copyright © 2004, Linear Technology Corporation



Стандарт Электрон Связь

Мы молодая и активно развивающаяся компания в области поставок электронных компонентов. Мы поставляем электронные компоненты отечественного и импортного производства напрямую от производителей и с крупнейших складов мира.

Благодаря сотрудничеству с мировыми поставщиками мы осуществляем комплексные и плановые поставки широчайшего спектра электронных компонентов.

Собственная эффективная логистика и склад в обеспечивает надежную поставку продукции в точно указанные сроки по всей России.

Мы осуществляем техническую поддержку нашим клиентам и предпродажную проверку качества продукции. На все поставляемые продукты мы предоставляем гарантию .

Осуществляем поставки продукции под контролем ВП МО РФ на предприятия военно-промышленного комплекса России , а также работаем в рамках 275 ФЗ с открытием отдельных счетов в уполномоченном банке. Система менеджмента качества компании соответствует требованиям ГОСТ ISO 9001.

Минимальные сроки поставки, гибкие цены, неограниченный ассортимент и индивидуальный подход к клиентам являются основой для выстраивания долгосрочного и эффективного сотрудничества с предприятиями радиоэлектронной промышленности, предприятиями ВПК и научно-исследовательскими институтами России.

С нами вы становитесь еще успешнее!

Наши контакты:

Телефон: +7 812 627 14 35

Электронная почта: sales@st-electron.ru

Адрес: 198099, Санкт-Петербург,
Промышленная ул, дом № 19, литера Н,
помещение 100-Н Офис 331