

BFN18

NPN Silicon High-Voltage Transistors

Data Sheet

Revision 1.0, 2010-10-13

Edition 2010-10-13

**Published by
Infineon Technologies AG
81726 Munich, Germany**

**© 2010 Infineon Technologies AG
All Rights Reserved.**

Legal Disclaimer

The information given in this document shall in no event be regarded as a guarantee of conditions or characteristics. With respect to any examples or hints given herein, any typical values stated herein and/or any information regarding the application of the device, Infineon Technologies hereby disclaims any and all warranties and liabilities of any kind, including without limitation, warranties of non-infringement of intellectual property rights of any third party.

Information

For further information on technology, delivery terms and conditions and prices, please contact the nearest Infineon Technologies Office (www.infineon.com).

Warnings

Due to technical requirements, components may contain dangerous substances. For information on the types in question, please contact the nearest Infineon Technologies Office.

Infineon Technologies components may be used in life-support devices or systems only with the express written approval of Infineon Technologies, if a failure of such components can reasonably be expected to cause the failure of that life-support device or system or to affect the safety or effectiveness of that device or system. Life support devices or systems are intended to be implanted in the human body or to support and/or maintain and sustain and/or protect human life. If they fail, it is reasonable to assume that the health of the user or other persons may be endangered.

Revision History

Page or Item	Subjects (major changes since previous revision)
Revision 1.0, 2010-10-13	
	Converted to the new IFX Template.

Trademarks of Infineon Technologies AG

AURIX™, BlueMoon™, COMNEON™, C166™, CROSSAVE™, CanPAK™, CIPOS™, CoolMOS™, CoolSET™, CORECONTROL™, DAVE™, EasyPIM™, EconoBRIDGE™, EconoDUAL™, EconoPACK™, EconoPIM™, EiceDRIVER™, EUPEC™, FCOS™, HITFET™, HybridPACK™, ISOFACE™, I²RF™, IsoPACK™, MIPAQ™, ModSTACK™, my-d™, NovalithIC™, OmniTune™, OptiMOS™, ORIGA™, PROFET™, PRO-SIL™, PRIMARION™, PrimePACK™, RASIC™, ReverSave™, SatRIC™, SIEGET™, SINDRION™, SMARTi™, SmartLEWIS™, TEMPFET™, thinQ!™, TriCore™, TRENCHSTOP™, X-GOLD™, XMM™, X-PMU™, XPOSYS™.

Other Trademarks

Advance Design System™ (ADS) of Agilent Technologies, AMBA™, ARM™, MULTI-ICE™, PRIMECELL™, REALVIEW™, THUMB™ of ARM Limited, UK. AUTOSAR™ is licensed by AUTOSAR development partnership. Bluetooth™ of Bluetooth SIG Inc. CAT-iq™ of DECT Forum. COLOSSUS™, FirstGPS™ of Trimble Navigation Ltd. EMV™ of EMVCo, LLC (Visa Holdings Inc.). EPCOS™ of Epcos AG. FLEXGO™ of Microsoft Corporation. FlexRay™ is licensed by FlexRay Consortium. HYPERTERMINAL™ of Hilgraeve Incorporated. IEC™ of Commission Electrotechnique Internationale. IrDA™ of Infrared Data Association Corporation. ISO™ of INTERNATIONAL ORGANIZATION FOR STANDARDIZATION. MATLAB™ of MathWorks, Inc. MAXIM™ of Maxim Integrated Products, Inc. MICROTEC™, NUCLEUS™ of Mentor Graphics Corporation. Mifare™ of NXP. MIPI™ of MIPI Alliance, Inc. MIPS™ of MIPS Technologies, Inc., USA. muRata™ of MURATA MANUFACTURING CO., MICROWAVE OFFICE™ (MWO) of Applied Wave Research Inc., OmniVision™ of OmniVision Technologies, Inc. Openwave™ Openwave Systems Inc. RED HAT™ Red Hat, Inc. RFMD™ RF Micro Devices, Inc. SIRIUS™ of Sirius Sattelite Radio Inc. SOLARIS™ of Sun Microsystems, Inc. SPANSION™ of Spansion LLC Ltd. Symbian™ of Symbian Software Limited. TAIYO YUDEN™ of Taiyo Yuden Co. TEAKLITE™ of CEVA, Inc. TEKTRONIX™ of Tektronix Inc. TOKO™ of TOKO KABUSHIKI KAISHA TA. UNIX™ of X/Open Company Limited. VERILOG™, PALLADIUM™ of Cadence Design Systems, Inc. VLYNQ™ of Texas Instruments Incorporated. VXWORKS™, WIND RIVER™ of WIND RIVER SYSTEMS, INC. ZETEX™ of Diodes Zetex Limited.

Last Trademarks Update 2010-06-09

Table of Contents

	Table of Contents	4
	List of Figures	5
	List of Tables	6
1	Features	7
2	Electrical Characteristics	8
3	Characteristic DC Diagrams	10
4	Package Information SOT89	12

1 Features

Main features:

- Suitable for video output stages TV sets and switching power supplies
- High breakdown voltage
- Low collector-emitter saturation voltage
- Complementary types: BFN19 (PNP)
- Pb-free (RoHS compliant) package¹⁾
- Qualified according AEC Q101

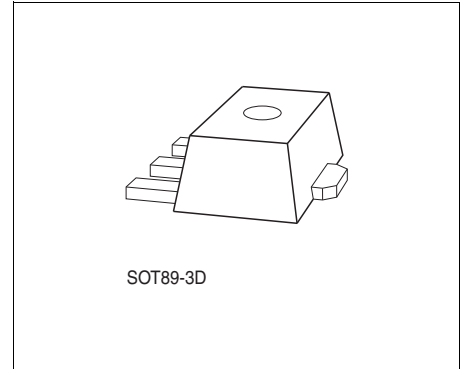

1) Pb-containing package may be available upon special request

Product Name	Package	Pin Configuration				Marking
		1 = B	2 = C	3 = E	4 = C	
BFN18	SOT89	1 = B	2 = C	3 = E	4 = C	DE

2 Electrical Characteristics

Table 1 Absolute Maximum Ratings

Parameter	Symbol	Values			Unit	Note / Test Condition
		Min.	Typ.	Max.		
Collector-emitter voltage	V_{CEO}	–	–	300	V	–
Collector-base voltage	V_{CBO}	–	–	300	V	–
Emitter-base voltage	V_{EBO}	–	–	5	V	–
Collector current	I_C	–	–	200	mA	–
Peak collector current	I_{CM}	–	–	500	mA	–
Base current	I_B	–	–	100	mA	–
Peak base current	I_{BM}	–	–	200	mA	–
Total power dissipation- $T_S = 120\text{ °C}$	P_{tot}	–	–	1.5	W	–
Junction temperature	T_j	–	–	150	°C	–
Storage temperature	T_{stg}	-65	–	150	°C	–

Attention: Stresses above the max. values listed here may cause permanent damage to the device. Exposure to absolute maximum rating conditions for extended periods may affect device reliability. Maximum ratings are absolute ratings; exceeding only one of these values may cause irreversible damage to the device.

Table 2 Thermal Resistance

Parameter	Symbol	Values			Unit	Note / Test Condition
		Min.	Typ.	Max.		
Junction - soldering point ¹⁾	R_{thJS}	–	–	≤ 20	K/W	–

1) For calculation of R_{thJA} please refer to Application Note Thermal Resistance.

Table 3 DC Characteristics at $T_A = 25\text{ °C}$, Unless Otherwise Specified

Parameter	Symbol	Values			Unit	Note / Test Condition
		Min.	Typ.	Max.		
Collector emitter breakdown voltage	$V_{(BR)CEO}$	300	–	–	V	$I_C = 1\text{ mA}, I_B = 0$
Collector-base breakdown voltage	$V_{(BR)CBO}$	300	–	–	V	$I_C = 100\text{ }\mu\text{A}, I_E = 0$
Emitter-base breakdown voltage	$V_{(BR)EBO}$	5	–	–	V	$I_E = 100\text{ }\mu\text{A}, I_C = 0$
Collector-base cutoff current	I_{CBO}	–	–	0.1	μA	$V_{CB} = 250\text{ V}, I_E = 0$
		–	–	20		
Emitter-base cutoff current	I_{EBO}	–	–	100	nA	$V_{EB} = 5\text{ V}, I_C = 0$
DC current gain ¹⁾	h_{FE}	25	–	–		$I_C = 1\text{ mA}, V_{CE} = 10\text{ V}$
		40	–	–		$I_C = 10\text{ mA}, V_{CE} = 10\text{ V}$
		30	–	–		$I_C = 30\text{ mA}, V_{CE} = 10\text{ V}$
Collector-emitter saturation voltage ¹⁾	V_{CEsat}	–	–	0.5	V	$I_C = 20\text{ mA}, I_B = 2\text{ mA}$
Base emitter saturation voltage ¹⁾	V_{BEsat}	–	–	0.9	V	$I_C = 20\text{ mA}, I_B = 2\text{ mA}$

1)Pulse test: $t < 300\text{ }\mu\text{s}$; $D < 2\%$

Table 4 AC Characteristics at $T_A = 25\text{ °C}$

Parameter	Symbol	Values			Unit	Note / Test Condition
		Min.	Typ.	Max.		
Transition frequency	f_T	–	70	–	MHz	$I_C = 20\text{ MHz}, V_{CE} = 10\text{ V},$ $f = 20\text{ MHz}$
Collector base capacitance	C_{Cb}	–	1.5	–	pF	$V_{CB} = 30\text{ V}, f = 1\text{ MHz}$

3 Characteristic DC Diagrams

DC Current Gain
 $h_{FE} = f(I_C), V_{CE} = 10 \text{ V}$

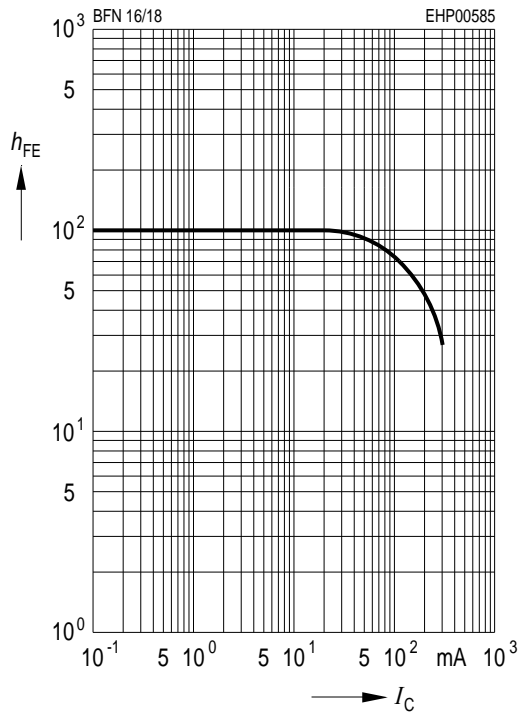

Operating Range
 $I_C = f(V_{CEO}), T_A = 25^\circ\text{C}, D = 0$

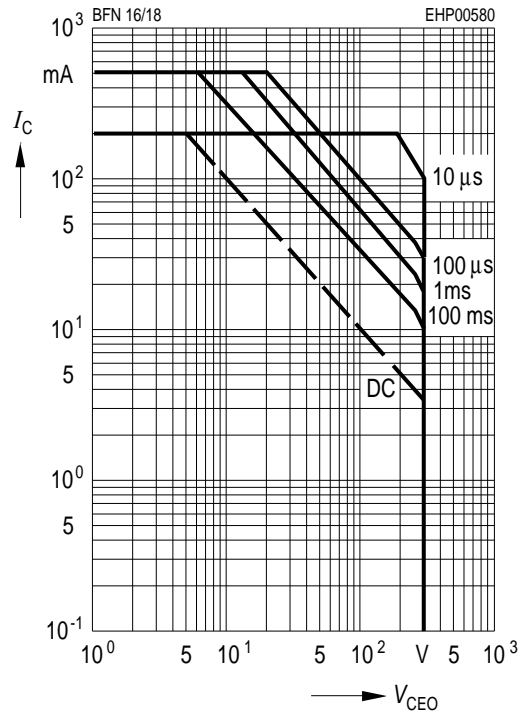

Collector Current
 $I_C = f(V_{BE}), V_{CE} = 10 \text{ V}$

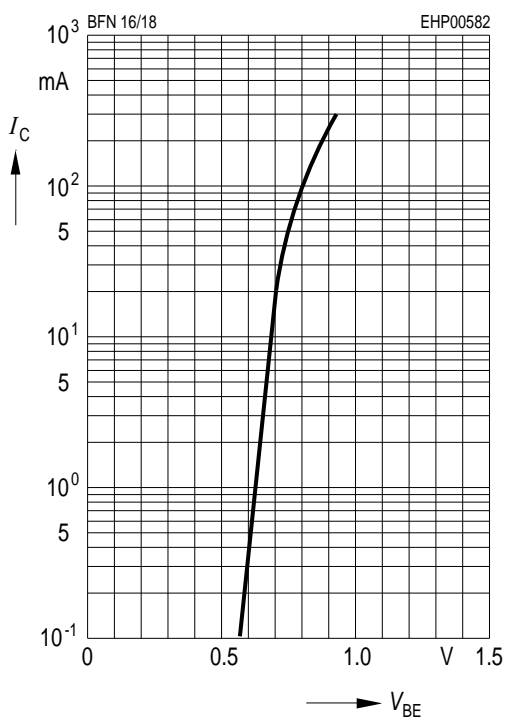

Collector Cutoff Current
 $I_{CBO} = f(T_A), V_{CBO} = 200 \text{ V}$

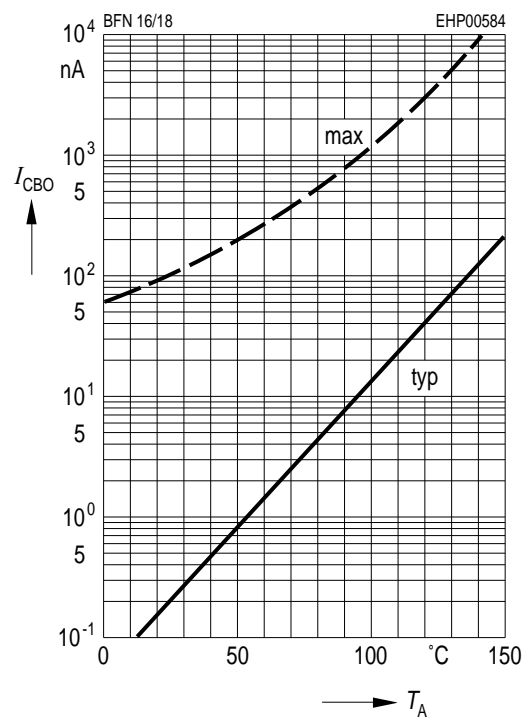

Characteristic DC Diagrams

Transition Frequency
 $f_T = f(I_C), V_{CE} = 10\text{ V}$

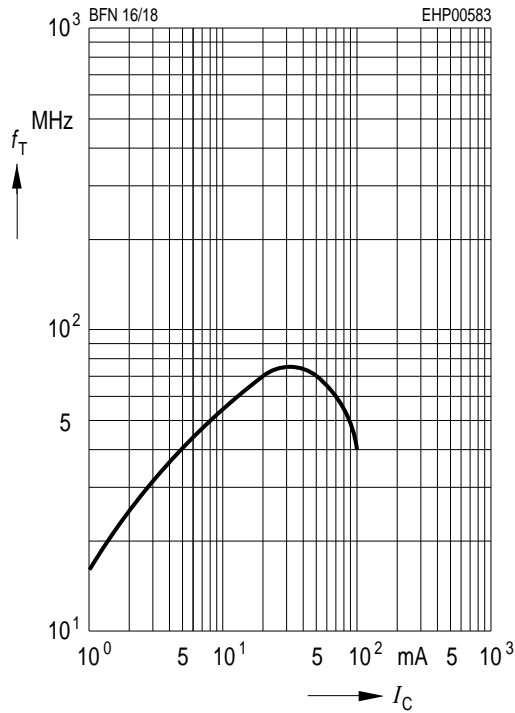

Collector Base Capacitance $C_{cb} = f(V_{CB})$
Emitter Base Capacitance $C_{eb} = f(V_{EB})$

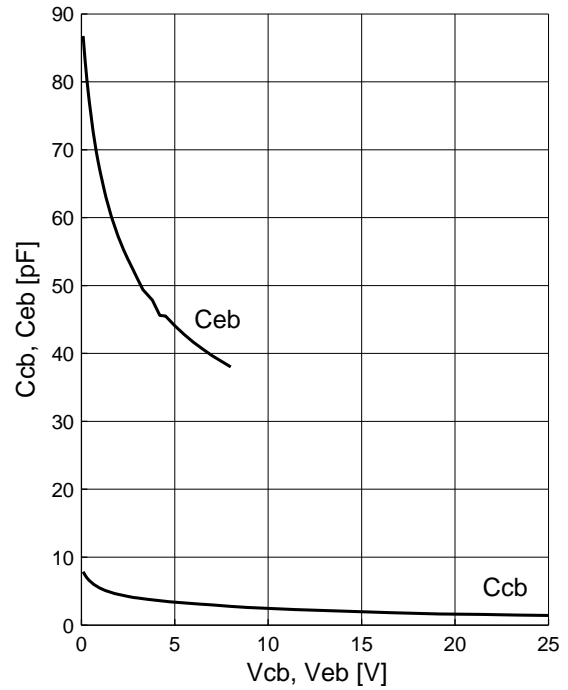

Total Power Dissipation
 $P_{tot} = f(T_S)$

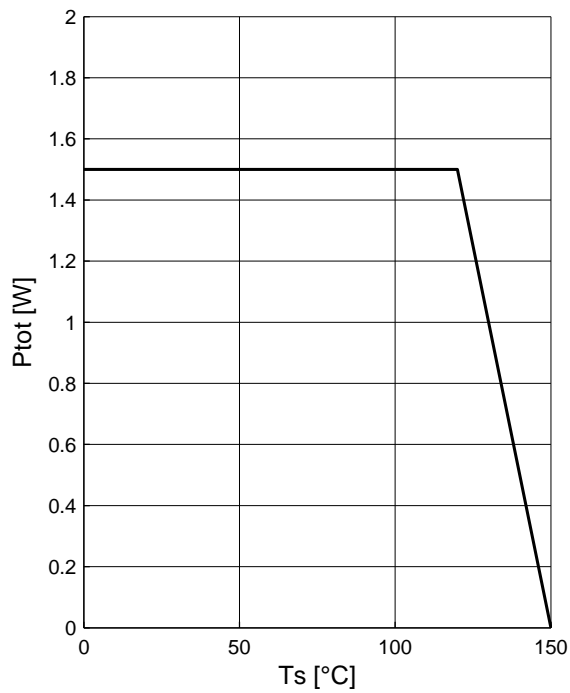

Permissible Pulse Load
 $P_{totmax} / P_{totDC} = f(T_S)$

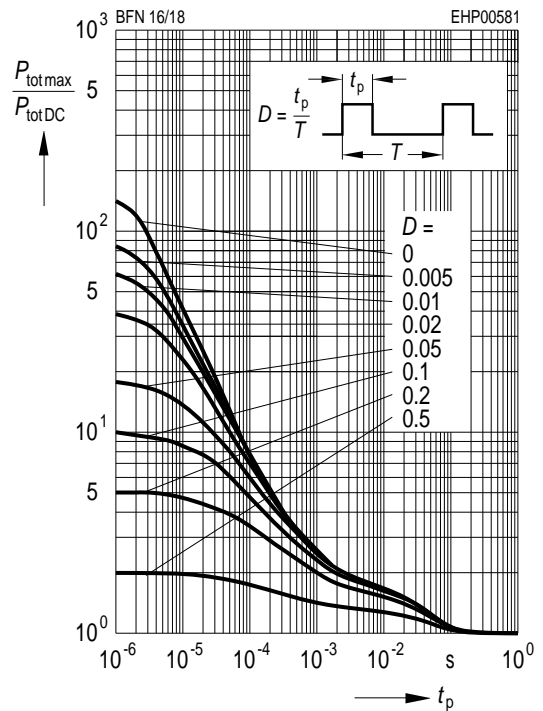

4 Package Information SOT89

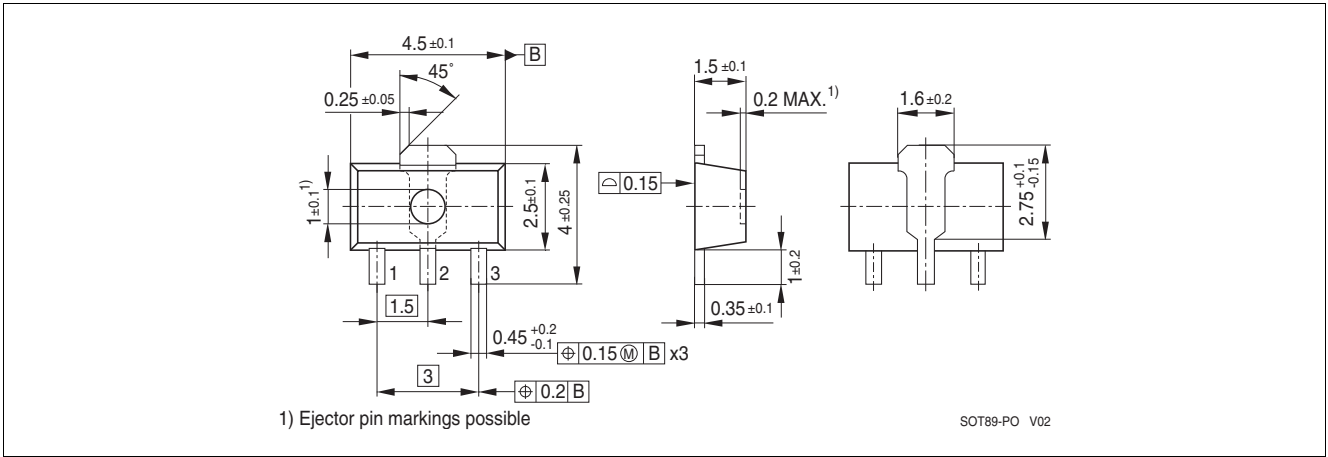

Figure 1 Package Outline

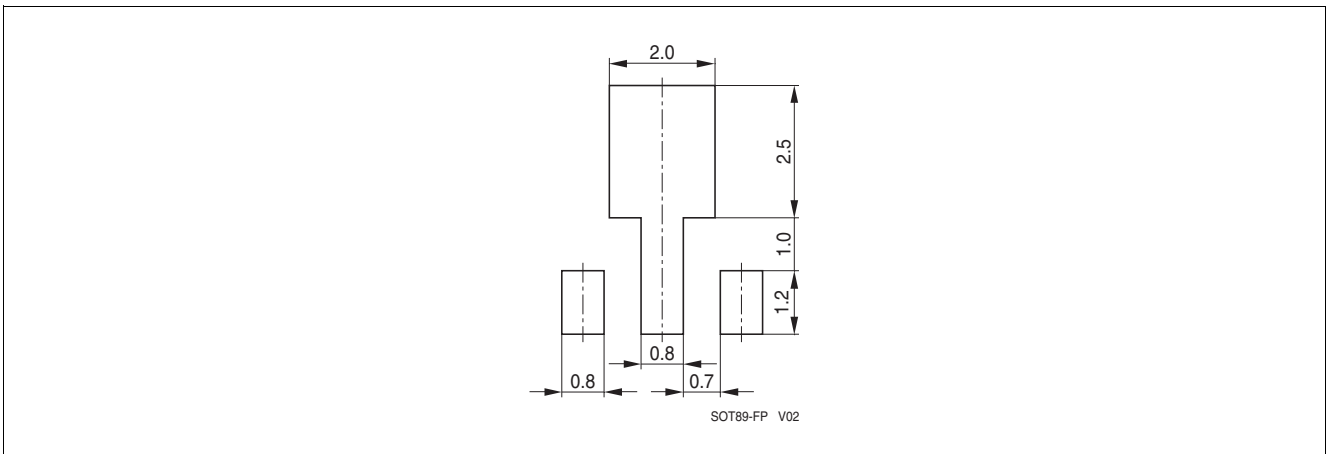

Figure 2 Package Foot Print

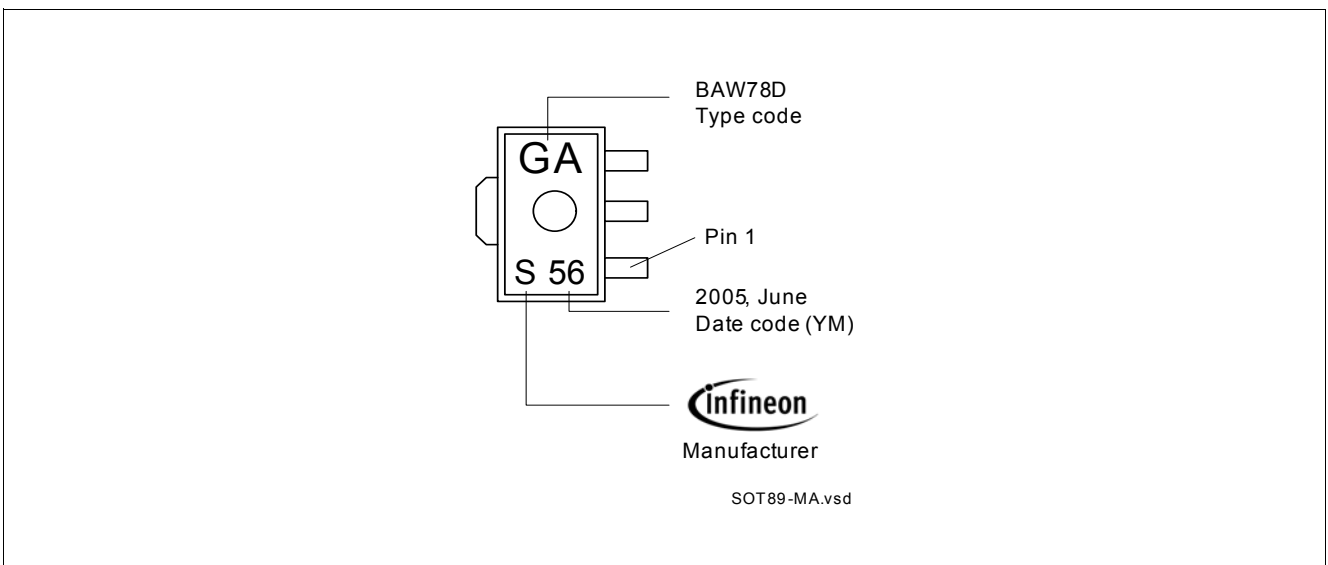

Figure 3 Marking Example

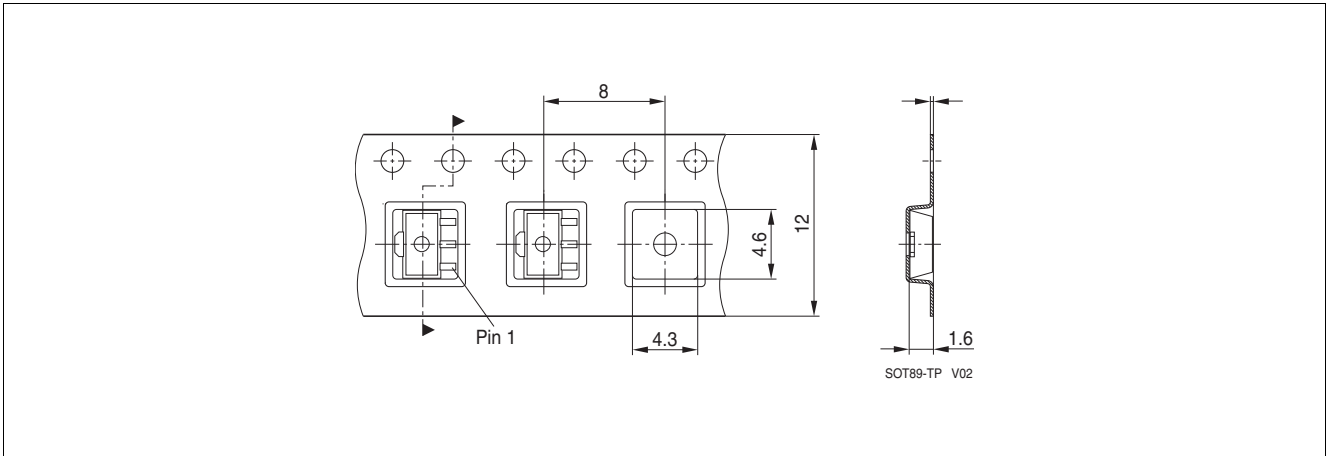

Figure 4 Tape Dimensions

Packing Description

Reel Ø180 mm = 1.000 Pieces/Reel

Reel Ø330 mm = 4.000 Pieces/Reel

www.infineon.com

Published by Infineon Technologies AG



Стандарт Электрон Связь

Мы молодая и активно развивающаяся компания в области поставок электронных компонентов. Мы поставляем электронные компоненты отечественного и импортного производства напрямую от производителей и с крупнейших складов мира.

Благодаря сотрудничеству с мировыми поставщиками мы осуществляем комплексные и плановые поставки широчайшего спектра электронных компонентов.

Собственная эффективная логистика и склад в обеспечивает надежную поставку продукции в точно указанные сроки по всей России.

Мы осуществляем техническую поддержку нашим клиентам и предпродажную проверку качества продукции. На все поставляемые продукты мы предоставляем гарантию .

Осуществляем поставки продукции под контролем ВП МО РФ на предприятия военно-промышленного комплекса России , а также работаем в рамках 275 ФЗ с открытием отдельных счетов в уполномоченном банке. Система менеджмента качества компании соответствует требованиям ГОСТ ISO 9001.

Минимальные сроки поставки, гибкие цены, неограниченный ассортимент и индивидуальный подход к клиентам являются основой для выстраивания долгосрочного и эффективного сотрудничества с предприятиями радиоэлектронной промышленности, предприятиями ВПК и научно-исследовательскими институтами России.

С нами вы становитесь еще успешнее!

Наши контакты:

Телефон: +7 812 627 14 35

Электронная почта: sales@st-electron.ru

Адрес: 198099, Санкт-Петербург,
Промышленная ул, дом № 19, литера Н,
помещение 100-Н Офис 331