

Ultra Low Power at 3.6V

- 110 μ A/MHz IBAT; DC-DC enabled
- 110 nA sleep current with data retention; POR monitor enabled
- 400 nA sleep current with smaRTClock (internal LFO)
- 700 nA sleep current with smaRTClock (external XTAL)
- 2 μ s wake-up from any sleep mode

12-Bit; 16 Ch. Analog-to-Digital Converter

- Up to 75 kps 12-bit mode or 300 kps 10-bit mode
- External pin or internal VREF (no external capacitor required)
- On-chip PGA allows measuring voltages up to twice the reference voltage
- Autonomous burst mode with 16-bit automatic averaging accumulator
- Integrated temperature sensor

Two Low Current Comparators

- Programmable hysteresis and response time
- Configurable as interrupt or reset source

Internal 6-Bit Current Reference

- Up to ± 500 μ A; source and sink capability
- Enhanced resolution via PWM interpolation

Integrated LCD Controller (Si102x Only)

- Supports up to 128 segments (32x4)
- Integrated charge pump for contrast control

Metering-Specific Peripherals

- DC-DC buck converter allows dynamic voltage scaling for maximum efficiency (250 mW output)
- Sleep-mode pulse accumulator with programmable switch de-bounce and pull-up control interfaces directly to metering sensor
- Dedicated Packet Processing Engine (DPPE) includes hardware AES, DMA, CRC, and encoding blocks for acceleration of wireless protocols
- Manchester and 3 out of 6 encoder hardware for power efficient implementation of the wireless M-bus specification

EZRADIOPRO[®] Transceiver

- Frequency range = 240–960 MHz
- Sensitivity = -121 dBm
- FSK, GFSK, and OOK modulation
- Max output power = +20 dBm or +13 dBm

- RF power consumption
 - 18.5 mA receive
 - 18 mA @ +1 dBm transmit
 - 30 mA @ +13 dBm transmit
 - 85 mA @ +20 dBm transmit
 - Data rate = 0.123 to 256 kbps
 - Auto-frequency calibration (AFC)
 - Antenna diversity and transmit/receive switch control
 - Programmable packet handler
 - TX and RX 64-byte FIFOs
 - Frequency hopping capability
 - On-chip crystal tuning

High-Speed 8051 μ C Core

- Pipelined instruction architecture; executes 70% of instructions in 1 or 2 system clocks

Memory

- Up to 128 kB Flash; In-system programmable; Full read/write/erase functionality over the entire supply range
- Up to 8 kB internal data RAM

Digital Peripherals

- 53 port I/O; All 5 V tolerant with high sink current and programmable drive strength
- Hardware SMBus[™] (I2C[™] compatible), 2 x SPI[™], and UART serial ports available concurrently
- Four general-purpose 16-bit counter/timers
- Programmable 16-bit counter/timer array with six capture/compare modules and watchdog timer

Clock Sources

- Precision internal oscillators: 24.5 MHz with $\pm 2\%$ accuracy supports UART operation; spread-spectrum mode for reduced EMI
- Low power internal oscillator: 20 MHz
- External oscillator: Crystal, RC, C, CMOS clock
- smaRTClock oscillator: 32.768 kHz crystal or 16.4 kHz internal LFO with three independent alarms

On-Chip Debug

- On-chip debug circuitry facilitates full-speed, non-intrusive, in-system debug (no emulator required)
- Provides 4 breakpoints, single stepping

Packages

- -85 pin LGA (6 x 8 mm)

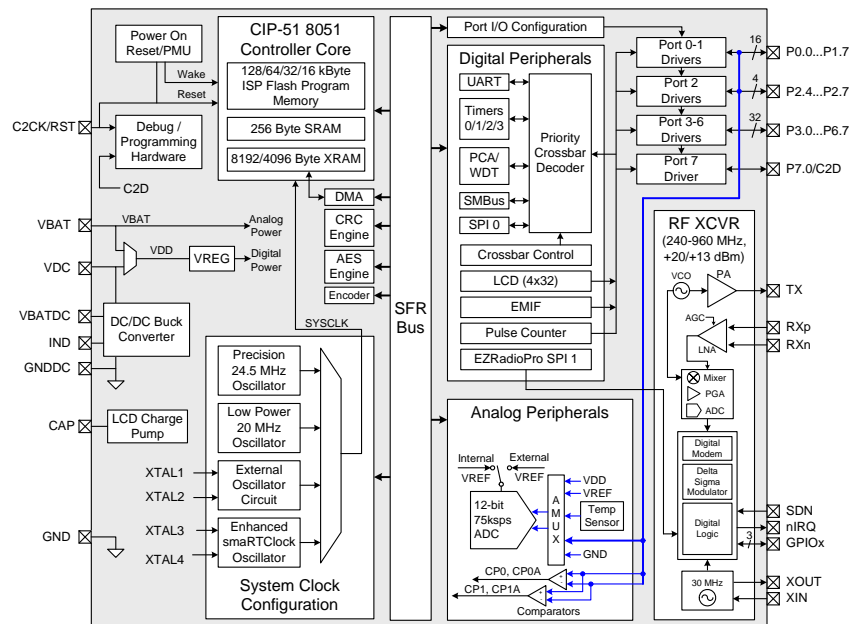

Si102x/3x



Table of Contents

1. System Overview	26
1.1. Typical Connection Diagram	29
1.2. CIP-51™ Microcontroller Core	30
1.2.1. Fully 8051 Compatible	30
1.2.2. Improved Throughput.....	30
1.2.3. Additional Features	30
1.3. Port Input/Output	31
1.4. Serial Ports	32
1.5. Programmable Counter Array.....	32
1.6. SAR ADC with 16-bit Auto-Averaging Accumulator and Autonomous Low Power Burst Mode.....	33
1.7. Programmable Current Reference (IREF0).....	34
1.8. Comparators.....	34
2. Ordering Information	36
3. Pinout and Package Definitions	37
3.1. LGA-85 Package Specifications	46
3.1.1. Package Drawing	46
3.1.2. Land Pattern.....	48
3.1.3. Soldering Guidelines	49
4. Electrical Characteristics	50
4.1. Absolute Maximum Specifications.....	50
4.2. MCU Electrical Characteristics	51
4.3. EZRadioPRO® Peripheral Electrical Characteristics	70
4.4. Definition of Test Conditions for the EZRadioPRO Peripheral	77
5. SAR ADC with 16-bit Auto-Averaging Accumulator and Autonomous Low Power Burst Mode	78
5.1. Output Code Formatting	78
5.2. Modes of Operation	80
5.2.1. Starting a Conversion.....	80
5.2.2. Tracking Modes.....	80
5.2.3. Burst Mode.....	82
5.2.4. Settling Time Requirements.....	83
5.2.5. Gain Setting	83
5.3. 8-Bit Mode	84
5.4. 12-Bit Mode	84
5.5. Low Power Mode.....	85
5.6. Programmable Window Detector.....	91
5.6.1. Window Detector In Single-Ended Mode	93
5.6.2. ADC0 Specifications	94
5.7. ADC0 Analog Multiplexer	95
5.8. Temperature Sensor.....	97
5.8.1. Calibration	97
5.9. Voltage and Ground Reference Options	100

Si102x/3x

5.10. External Voltage Reference.....	101
5.11. Internal Voltage Reference.....	101
5.12. Analog Ground Reference.....	101
5.13. Temperature Sensor Enable	101
5.14. Voltage Reference Electrical Specifications	102
6. Comparators.....	103
6.1. Comparator Inputs.....	103
6.2. Comparator Outputs.....	104
6.3. Comparator Response Time	105
6.4. Comparator Hysteresis	105
6.5. Comparator Register Descriptions	106
7. Programmable Current Reference (IREF0).....	110
7.1. PWM Enhanced Mode.....	110
7.2. IREF0 Specifications	111
7.3. Comparator0 and Comparator1 Analog Multiplexers	112
8. CIP-51 Microcontroller.....	115
8.1. Instruction Set.....	116
8.1.1. Instruction and CPU Timing	116
8.2. CIP-51 Register Descriptions	121
9. Memory Organization	124
9.1. Program Memory.....	124
9.1.1. MOVX Instruction and Program Memory	127
9.2. Data Memory	127
9.2.1. Internal RAM	128
9.2.2. External RAM.....	128
10. External Data Memory Interface and On-Chip XRAM	130
10.1. Accessing XRAM.....	130
10.1.1. 16-Bit MOVX Example	130
10.1.2. 8-Bit MOVX Example	130
10.2. Configuring the External Memory Interface	131
10.3. Port Configuration.....	131
10.4. Multiplexed and Non-Multiplexed Selection.....	135
10.4.1. Multiplexed Configuration.....	135
10.4.2. Non-Multiplexed Configuration.....	135
10.5. Memory Mode Selection.....	136
10.5.1. Internal XRAM Only	137
10.5.2. Split Mode without Bank Select.....	137
10.5.3. Split Mode with Bank Select.....	137
10.5.4. External Only.....	137
10.6. Timing	138
10.6.1. Non-Multiplexed Mode	140
10.6.2. Multiplexed Mode	143
11. Direct Memory Access (DMA0).....	147
11.1. DMA0 Architecture	148
11.2. DMA0 Arbitration	149

11.2.1. DMA0 Memory Access Arbitration	149
11.2.2. DMA0 Channel Arbitration	149
11.3. DMA0 Operation in Low Power Modes	149
11.4. Transfer Configuration.....	150
12. Cyclic Redundancy Check Unit (CRC0).....	161
12.1. 16-bit CRC Algorithm.....	161
12.3. Preparing for a CRC Calculation	164
12.4. Performing a CRC Calculation	164
12.5. Accessing the CRC0 Result	164
12.6. CRC0 Bit Reverse Feature.....	168
13. DMA-Enabled Cyclic Redundancy Check Module (CRC1).....	169
13.1. Polynomial Specification.....	169
13.2. Endianness.....	170
13.3. CRC Seed Value	171
13.4. Inverting the Final Value.....	171
13.5. Flipping the Final Value	171
13.6. Using CRC1 with SFR Access	172
13.7. Using the CRC1 module with the DMA	172
14. Advanced Encryption Standard (AES) Peripheral.....	176
14.1. Hardware Description	177
14.1.1. AES Encryption/Decryption Core	178
14.1.2. Data SFRs.....	178
14.1.3. Configuration sfrs	179
14.1.4. Input Multiplexer.....	179
14.1.5. Output Multiplexer	179
14.1.6. Internal State Machine	179
14.2. Key Inversion.....	180
14.2.1. Key Inversion using DMA.....	181
14.2.2. Key Inversion using SFRs.....	182
14.2.3. Extended Key Output Byte Order.....	183
14.2.4. Using the DMA to unwrap the extended Key	184
14.3. AES Block Cipher.....	185
14.4. AES Block Cipher Data Flow.....	186
14.4.1. AES Block Cipher Encryption using DMA	187
14.4.2. AES Block Cipher Encryption using SFRs	188
14.5. AES Block Cipher Decryption.....	189
14.5.1. AES Block Cipher Decryption using DMA.....	189
14.5.2. AES Block Cipher Decryption using SFRs.....	190
14.6. Block Cipher Modes	191
14.6.1. Cipher Block Chaining Mode.....	191
14.6.2. CBC Encryption Initialization Vector Location.....	193
14.6.3. CBC Encryption using DMA	193
14.6.4. CBC Decryption	196
14.6.5. Counter Mode	199
14.6.6. CTR Encryption using DMA	201

Si102x/3x

15. Encoder/Decoder	208
15.1. Manchester Encoding.....	209
15.2. Manchester Decoding.....	210
15.3. Three-out-of-Six Encoding.....	211
15.4. Three-out-of-Six Decoding	212
15.5. Encoding/Decoding with SFR Access	213
15.6. Decoder Error Interrupt.....	213
15.7. Using the ENC0 module with the DMA.....	214
16. Special Function Registers.....	217
16.1. SFR Paging	217
16.2. Interrupts and SFR Paging.....	217
16.3. SFR Page Stack Example	219
17. Interrupt Handler.....	238
17.1. Enabling Interrupt Sources.....	238
17.2. MCU Interrupt Sources and Vectors.....	238
17.3. Interrupt Priorities	239
17.4. Interrupt Latency.....	239
17.5. Interrupt Register <u>Descriptions</u>	241
17.6. External Interrupts INT0 and INT1.....	248
18. Flash Memory.....	250
18.1. Programming the Flash Memory	250
18.1.1. Flash Lock and Key Functions	250
18.1.2. Flash Erase Procedure	250
18.1.3. Flash Write Procedure	251
18.1.4. Flash Write Optimization.....	252
18.2. Non-volatile Data Storage	253
18.3. Security Options	253
18.4. Determining the Device Part Number at Run Time	255
18.5. Flash Write and Erase Guidelines.....	256
18.5.1. VDD Maintenance and the VDD Monitor	256
18.5.2. PSWE Maintenance	258
18.5.3. System Clock	258
18.6. Minimizing Flash Read Current	259
19. Power Management	264
19.1. Normal Mode	265
19.2. Idle Mode.....	265
19.3. Stop Mode	266
19.4. Low Power Idle Mode	266
19.5. Suspend Mode	270
19.6. Sleep Mode	270
19.7. Configuring Wakeup Sources.....	271
19.8. Determining the Event that Caused the Last Wakeup.....	271
19.9. Power Management Specifications	275
20. On-Chip DC-DC Buck Converter (DC0).....	276
20.1. Startup Behavior.....	277

20.4. Optimizing Board Layout	278
20.5. Selecting the Optimum Switch Size.....	278
20.6. DC-DC Converter Clocking Options	278
20.7. Bypass Mode.....	279
20.8. DC-DC Converter Register Descriptions	279
20.9. DC-DC Converter Specifications	283
21. Voltage Regulator (VREG0)	284
21.1. Voltage Regulator Electrical Specifications	284
22. Reset Sources	285
22.1. Power-On Reset	286
22.2. Power-Fail Reset.....	287
22.3. External Reset	290
22.4. Missing Clock Detector Reset	290
22.5. Comparator0 Reset	290
22.6. PCA Watchdog Timer Reset	290
22.7. Flash Error Reset	291
22.8. SmarTclock (Real Time Clock) Reset	291
22.9. Software Reset.....	291
23. Clocking Sources	293
23.1. Programmable Precision Internal Oscillator	294
23.2. Low Power Internal Oscillator.....	294
23.3. External Oscillator Drive Circuit.....	294
23.3.1. External Crystal Mode.....	294
23.3.2. External RC Mode.....	296
23.3.3. External Capacitor Mode.....	297
23.3.4. External CMOS Clock Mode	297
23.4. Special Function Registers for Selecting and Configuring the System Clock	298
24. SmarTclock (Real Time Clock)	302
24.1. SmarTclock Interface	303
24.1.1. SmarTclock Lock and Key Functions.....	304
24.1.2. Using RTC0ADR and RTC0DAT to Access SmarTclock Internal Registers	304
24.1.3. SmarTclock Interface Autoread Feature	304
24.1.4. RTC0ADR Autoincrement Feature.....	304
24.2. SmarTclock Clocking Sources	307
24.2.1. Using the SmarTclock Oscillator with a Crystal or External CMOS Clock.....	307
24.2.2. Using the SmarTclock Oscillator in Self-Oscillate Mode.....	308
24.2.3. Using the Low Frequency Oscillator (LFO)	308
24.2.4. Programmable Load Capacitance.....	308
24.2.5. Automatic Gain Control (Crystal Mode Only) and SmarTclock Bias Doubling	309
24.2.6. Missing SmarTclock Detector	311
24.2.7. SmarTclock Oscillator Crystal Valid Detector	311

Si102x/3x

24.3. SmarTClock Timer and Alarm Function	311
24.3.1. Setting and Reading the SmarTClock Timer Value	311
24.3.2. Setting a SmarTClock Alarm	312
24.3.3. Software Considerations for using the SmarTClock Timer and Alarm	312
25. Low-Power Pulse Counter	319
25.1. Counting Modes	320
25.2. Reed Switch Types.....	321
25.3. Programmable Pull-Up Resistors	322
25.4. Automatic Pull-Up Resistor Calibration	324
25.5. Sample Rate.....	324
25.6. Debounce	324
25.7. Reset Behavior	325
25.8. Wake up and Interrupt Sources.....	325
25.9. Real-Time Register Access	326
25.10. Advanced Features	326
25.10.1. Quadrature Error.....	326
25.10.2. Flutter Detection.....	327
26. LCD Segment Driver (Si102x Only)	341
26.1. Configuring the LCD Segment Driver	341
26.2. Mapping Data Registers to LCD Pins.....	342
26.3. LCD Contrast Adjustment.....	345
26.3.1. Contrast Control Mode 1 (Bypass Mode).....	345
26.3.2. Contrast Control Mode 2 (Minimum Contrast Mode)	346
26.3.3. Contrast Control Mode 3 (Constant Contrast Mode).....	346
26.3.4. Contrast Control Mode 4 (Auto-Bypass Mode)	347
26.4. Adjusting the VBAT Monitor Threshold	351
26.5. Setting the LCD Refresh Rate	352
26.6. Blinking LCD Segments.....	353
26.7. Advanced LCD Optimizations.....	355
27. Port Input/Output	358
27.1. Port I/O Modes of Operation.....	359
27.1.1. Port Pins Configured for Analog I/O.....	359
27.1.2. Port Pins Configured For Digital I/O.....	359
27.1.3. Interfacing Port I/O to High Voltage Logic.....	360
27.1.4. Increasing Port I/O Drive Strength	360
27.2. Assigning Port I/O Pins to Analog and Digital Functions.....	360
27.2.1. Assigning Port I/O Pins to Analog Functions	360
27.2.2. Assigning Port I/O Pins to Digital Functions.....	361
27.2.3. Assigning Port I/O Pins to External Digital Event Capture Functions ...	361
27.3. Priority Crossbar Decoder	362
27.4. Port Match	368
27.5. Special Function Registers for Accessing and Configuring Port I/O	370
28. SMBus.....	388
28.1. Supporting Documents	389

28.2. SMBus Configuration.....	389
28.3. SMBus Operation	389
28.3.1. Transmitter Vs. Receiver.....	390
28.3.2. Arbitration.....	390
28.3.3. Clock Low Extension.....	390
28.3.4. SCL Low Timeout.....	390
28.3.5. SCL High (SMBus Free) Timeout	391
28.4. Using the SMBus.....	391
28.4.1. SMBus Configuration Register.....	391
28.4.2. SMB0CN Control Register	395
28.4.3. Hardware Slave Address Recognition	397
28.4.4. Data Register	400
28.5. SMBus Transfer Modes.....	400
28.5.1. Write Sequence (Master)	400
28.5.2. Read Sequence (Master).....	401
28.5.3. Write Sequence (Slave)	402
28.5.4. Read Sequence (Slave).....	403
28.6. SMBus Status Decoding.....	404
29. UART0	409
29.1. Enhanced Baud Rate Generation.....	410
29.2. Operational Modes	411
29.2.1. 8-Bit UART	411
29.2.2. 9-Bit UART	411
29.3. Multiprocessor Communications	412
30. Enhanced Serial Peripheral Interface (SPI0)	418
30.1. Signal Descriptions.....	419
30.1.1. Master Out, Slave In (MOSI).....	419
30.1.2. Master In, Slave Out (MISO).....	419
30.1.3. Serial Clock (SCK)	419
30.1.4. Slave Select (NSS)	419
30.2. SPI0 Master Mode Operation	419
30.3. SPI0 Slave Mode Operation	421
30.4. SPI0 Interrupt Sources	422
30.5. Serial Clock Phase and Polarity	422
30.6. SPI Special Function Registers	424
31. EZRadioPRO® Serial Interface	431
31.1. Signal Descriptions.....	432
31.1.1. Master Out, Slave In (MOSI).....	432
31.1.2. Master In, Slave Out (MISO).....	432
31.1.3. Serial Clock (SCK)	432
31.1.4. Slave Select (NSS)	432
31.2. SPI1 Master Mode Operation.....	433
31.3. SPI Slave Operation on the EZRadioPRO Peripheral Side.....	433
31.4. SPI1 Interrupt Sources	433
31.5. Serial Clock Phase and Polarity	434

Si102x/3x

31.6. Using SPI1 with the DMA	435
31.7. Master Mode SPI1 DMA Transfers.....	435
31.8. Master Mode Bidirectional Data Transfer.....	435
31.9. Master Mode Unidirectional Data Transfer.....	437
31.10. SPI Special Function Registers.....	437
32. EZRadioPRO® 240–960 MHz Transceiver.....	443
32.1. EZRadioPRO Operating Modes	444
32.1.1. Operating Mode Control	445
32.2. Interrupts	447
32.3. System Timing.....	448
32.3.1. Frequency Control.....	449
32.3.2. Frequency Programming.....	449
32.3.3. Easy Frequency Programming for FHSS.....	451
32.3.4. Automatic State Transition for Frequency Change	452
32.3.5. Frequency Deviation	452
32.3.6. Frequency Offset Adjustment.....	453
32.3.7. Automatic Frequency Control (AFC).....	453
32.3.8. TX Data Rate Generator	455
32.4. Modulation Options.....	455
32.4.1. Modulation Type.....	455
32.4.2. Modulation Data Source.....	456
32.4.3. PN9 Mode	460
32.5. Internal Functional Blocks	460
32.5.1. RX LNA	460
32.5.2. RX I-Q Mixer	460
32.5.3. Programmable Gain Amplifier.....	460
32.5.4. ADC	461
32.5.5. Digital Modem	461
32.5.6. Synthesizer	462
32.5.7. Power Amplifier	463
32.5.8. Crystal Oscillator.....	464
32.5.9. Regulators.....	464
32.6. Data Handling and Packet Handler	465
32.6.1. RX and TX FIFOs.....	465
32.6.2. Packet Configuration.....	466
32.6.3. Packet Handler TX Mode.....	467
32.6.4. Packet Handler RX Mode.....	467
32.6.5. Data Whitening, Manchester Encoding, and CRC	469
32.6.6. Preamble Detector	470
32.6.7. Preamble Length.....	470
32.6.8. Invalid Preamble Detector.....	471
32.6.9. Synchronization Word Configuration.....	471
32.6.10. Receive Header Check	472
32.6.11. TX Retransmission and Auto TX.....	472
32.7. RX Modem Configuration	473

32.7.1. Modem Settings for FSK and GFSK	473
32.8. Auxiliary Functions	473
32.8.1. Smart Reset	473
32.8.2. Output Clock	474
32.8.3. General Purpose ADC	475
32.8.4. Temperature Sensor	476
32.8.5. Low Battery Detector.....	478
32.8.6. Wake-Up Timer and 32 kHz Clock Source	479
32.8.7. Low Duty Cycle Mode	481
32.8.8. GPIO Configuration.....	482
32.8.9. Antenna Diversity	483
32.8.10. RSSI and Clear Channel Assessment	483
32.9. Reference Design.....	484
32.10. Application Notes and Reference Designs	487
32.11. Customer Support	487
32.12. Register Table and Descriptions	488
32.13. Required Changes to Default Register Values.....	490
33. Timers	491
33.1. Timer 0 and Timer 1	493
33.1.1. Mode 0: 13-bit Counter/Timer	493
33.1.2. Mode 1: 16-bit Counter/Timer	494
33.1.3. Mode 2: 8-bit Counter/Timer with Auto-Reload.....	494
33.1.4. Mode 3: Two 8-bit Counter/Timers (Timer 0 Only).....	495
33.2. Timer 2	501
33.2.1. 16-bit Timer with Auto-Reload.....	501
33.2.2. 8-bit Timers with Auto-Reload.....	502
33.2.3. Comparator 0/SmaRTClock Capture Mode	502
33.3. Timer 3	507
33.3.1. 16-bit Timer with Auto-Reload.....	507
33.3.2. 8-Bit Timers with Auto-Reload	508
33.3.3. SmaRTClock/External Oscillator Capture Mode	508
34. Programmable Counter Array.....	513
34.1. PCA Counter/Timer	514
34.2. PCA0 Interrupt Sources.....	515
34.3. Capture/Compare Modules	516
34.3.1. Edge-triggered Capture Mode.....	517
34.3.2. Software Timer (Compare) Mode.....	518
34.3.3. High-Speed Output Mode	519
34.3.4. Frequency Output Mode	520
34.3.5. 8-Bit, 9-Bit, 10-Bit and 11-Bit Pulse Width Modulator Modes.....	521
34.3.6. 16-Bit Pulse Width Modulator Mode.....	523
34.4. Watchdog Timer Mode	524
34.4.1. Watchdog Timer Operation	524
34.4.2. Watchdog Timer Usage	525
34.5. Register Descriptions for PCA0.....	527

Si102x/3x

35. C2 Interface	533
35.1. C2 Interface Registers.....	533
35.2. C2 Pin Sharing	536
Contact Information	538



List of Figures

Figure 1.1. Si102x Block Diagram	28
Figure 1.2. Si103x Block Diagram	28
Figure 1.3. Si102x/3x RX/TX Direct-tie Application Example	29
Figure 1.4. Si102x/3x Antenna Diversity Application Example	29
Figure 1.5. Port I/O Functional Block Diagram	31
Figure 1.6. PCA Block Diagram	32
Figure 1.7. ADC0 Functional Block Diagram	33
Figure 1.8. ADC0 Multiplexer Block Diagram	34
Figure 1.9. Comparator 0 Functional Block Diagram	35
Figure 1.10. Comparator 1 Functional Block Diagram	35
Figure 3.1. LGA-85 Pinout Diagram (Top View)	45
Figure 3.2. LGA-85 Package Drawing	46
Figure 3.3. LGA-85 Land Pattern	48
Figure 4.1. Frequency Sensitivity (External CMOS Clock, 25°C)	56
Figure 4.2. Typical VOH Curves, 1.8–3.8 V	58
Figure 4.3. Typical VOL Curves, 1.8–3.8 V	59
Figure 5.1. ADC0 Functional Block Diagram	78
Figure 5.2. 10-Bit ADC Track and Conversion Example Timing (BURSTEN = 0)	81
Figure 5.3. Burst Mode Tracking Example with Repeat Count Set to 4	82
Figure 5.4. ADC0 Equivalent Input Circuits	83
Figure 5.5. ADC Window Compare Example: Right-Justified Single-Ended Data	94
Figure 5.6. ADC Window Compare Example: Left-Justified Single-Ended Data	94
Figure 5.7. ADC0 Multiplexer Block Diagram	95
Figure 5.8. Temperature Sensor Transfer Function	97
Figure 5.9. Temperature Sensor Error with 1-Point Calibration ($V_{REF} = 1.68\text{ V}$)	98
Figure 5.10. Voltage Reference Functional Block Diagram	100
Figure 6.1. Comparator 0 Functional Block Diagram	103
Figure 6.2. Comparator 1 Functional Block Diagram	104
Figure 6.3. Comparator Hysteresis Plot	105
Figure 7.1. CPn Multiplexer Block Diagram	112
Figure 8.1. CIP-51 Block Diagram	115
Figure 9.1. Si102x/3x Memory Map	124
Figure 9.2. Flash Program Memory Map	125
Figure 9.3. Address Memory Map for Instruction Fetches	126
Figure 10.1. Multiplexed Configuration Example	135
Figure 10.2. Non-Multiplexed Configuration Example	136
Figure 10.3. EMIF Operating Modes	136
Figure 10.4. Non-Multiplexed 16-bit MOVX Timing	140
Figure 10.5. Non-Multiplexed 8-bit MOVX without Bank Select Timing	141

Figure 10.6. Non-Multiplexed 8-bit MOVX with Bank Select Timing	142
Figure 10.7. Multiplexed 16-bit MOVX Timing	143
Figure 10.8. Multiplexed 8-bit MOVX without Bank Select Timing	144
Figure 10.9. Multiplexed 8-bit MOVX with Bank Select Timing	145
Figure 11.1. DMA0 Block Diagram	148
Figure 12.1. CRC0 Block Diagram	161
Figure 12.2. Bit Reverse Register	168
Figure 13.1. Polynomial Representation	169
Figure 14.1. AES Peripheral Block Diagram	177
Figure 14.2. Key Inversion Data Flow	180
Figure 14.3. AES Block Cipher Data Flow	186
Figure 14.4. Cipher Block Chaining Mode	191
Figure 14.5. CBC Encryption Data Flow	192
Figure 14.6. CBC Decryption Data Flow	196
Figure 14.7. Counter Mode	199
Figure 14.8. Counter Mode Data Flow	200
Figure 16.1. SFR Page Stack	218
Figure 16.2. SFR Page Stack While Using SFR Page 0x0 To Access SMB0ADR	219
Figure 16.3. SFR Page Stack After SPI0 Interrupt Occurs	220
Figure 16.4. SFR Page Stack Upon PCA Interrupt Occurring During a SPI0 ISR	221
Figure 16.5. SFR Page Stack Upon Return From PCA Interrupt	222
Figure 16.6. SFR Page Stack Upon Return From SPI0 Interrupt	223
Figure 18.1. Flash Security Example	253
Figure 19.1. Si102x/3x Power Distribution	265
Figure 19.2. Clock Tree Distribution	266
Figure 20.1. Step Down DC-DC Buck Converter Block Diagram	276
Figure 22.1. Reset Sources	285
Figure 22.2. Power-On Reset Timing Diagram	286
Figure 23.1. Clocking Sources Block Diagram	293
Figure 23.2. 25 MHz External Crystal Example	295
Figure 24.1. SmaRTClock Block Diagram	302
Figure 24.2. Interpreting Oscillation Robustness (Duty Cycle) Test Results	310
Figure 25.1. Pulse Counter Block Diagram	319
Figure 25.2. Mode Examples	320
Figure 25.3. Reed Switch Configurations	321
Figure 25.4. Debounce Timing	325
Figure 25.5. Flutter Example	327
Figure 26.1. LCD Segment Driver Block Diagram	341
Figure 26.2. LCD Data Register to LCD Pin Mapping	343
Figure 26.3. Contrast Control Mode 1	345
Figure 26.4. Contrast Control Mode 2	346
Figure 26.5. Contrast Control Mode 3	346
Figure 26.6. Contrast Control Mode 4	347

Figure 27.1. Port I/O Functional Block Diagram	358
Figure 27.2. Port I/O Cell Block Diagram	359
Figure 27.3. Crossbar Priority Decoder with No Pins Skipped	363
Figure 27.4. Crossbar Priority Decoder with Crystal Pins Skipped	364
Figure 28.1. SMBus Block Diagram	388
Figure 28.2. Typical SMBus Configuration	389
Figure 28.3. SMBus Transaction	390
Figure 28.4. Typical SMBus SCL Generation	392
Figure 28.5. Typical Master Write Sequence	401
Figure 28.6. Typical Master Read Sequence	402
Figure 28.7. Typical Slave Write Sequence	403
Figure 28.8. Typical Slave Read Sequence	404
Figure 29.1. UART0 Block Diagram	409
Figure 29.2. UART0 Baud Rate Logic	410
Figure 29.3. UART Interconnect Diagram	411
Figure 29.4. 8-Bit UART Timing Diagram	411
Figure 29.5. 9-Bit UART Timing Diagram	412
Figure 29.6. UART Multi-Processor Mode Interconnect Diagram	413
Figure 30.1. SPI Block Diagram	418
Figure 30.2. Multiple-Master Mode Connection Diagram	421
Figure 30.3. 3-Wire Single Master and 3-Wire Single Slave Mode Connection Diagram	421
Figure 30.4. 4-Wire Single Master Mode and 4-Wire Slave Mode Connection Diagram	421
Figure 30.5. Master Mode Data/Clock Timing	423
Figure 30.6. Slave Mode Data/Clock Timing (CKPHA = 0)	423
Figure 30.7. Slave Mode Data/Clock Timing (CKPHA = 1)	424
Figure 30.8. SPI Master Timing (CKPHA = 0)	428
Figure 30.9. SPI Master Timing (CKPHA = 1)	428
Figure 30.10. SPI Slave Timing (CKPHA = 0)	429
Figure 30.11. SPI Slave Timing (CKPHA = 1)	429
Figure 31.1. SPI Block Diagram	431
Figure 31.2. Master Mode Data/Clock Timing	434
Figure 31.3. SPI Master Timing (CKPHA = 0)	441
Figure 32.1. State Machine Diagram	445
Figure 32.2. TX Timing	448
Figure 32.3. RX Timing	449
Figure 32.4. Frequency Deviation	452
Figure 32.5. Sensitivity at 1% PER vs. Carrier Frequency Offset	454
Figure 32.6. FSK vs. GFSK Spectrums	456
Figure 32.7. Direct Synchronous Mode Example	459
Figure 32.8. Direct Asynchronous Mode Example	459
Figure 32.9. Microcontroller Connections	460
Figure 32.10. PLL Synthesizer Block Diagram	462
Figure 32.11. FIFO Thresholds	465

Si102x/3x

Figure 32.12. Packet Structure	466
Figure 32.13. Multiple Packets in TX Packet Handler	467
Figure 32.14. Required RX Packet Structure with Packet Handler Disabled	467
Figure 32.15. Multiple Packets in RX Packet Handler	468
Figure 32.16. Multiple Packets in RX with CRC or Header Error	468
Figure 32.17. Operation of Data Whitening, Manchester Encoding, and CRC	470
Figure 32.18. Manchester Coding Example	470
Figure 32.19. Header	472
Figure 32.20. POR Glitch Parameters	473
Figure 32.21. General Purpose ADC Architecture	476
Figure 32.22. Temperature Ranges using ADC8	478
Figure 32.23. WUT Interrupt and WUT Operation	481
Figure 32.24. Low Duty Cycle Mode	482
Figure 32.25. RSSI Value vs. Input Power	484
Figure 32.26. Si1024 Split RF TX/RX Direct-Tie Reference Design—Schematic	485
Figure 32.27. Si1020 Switch Matching Reference Design—Schematic	486
Figure 33.1. T0 Mode 0 Block Diagram	494
Figure 33.2. T0 Mode 2 Block Diagram	495
Figure 33.3. T0 Mode 3 Block Diagram	496
Figure 33.4. Timer 2 16-Bit Mode Block Diagram	501
Figure 33.5. Timer 2 8-Bit Mode Block Diagram	502
Figure 33.6. Timer 2 Capture Mode Block Diagram	503
Figure 33.7. Timer 3 16-Bit Mode Block Diagram	507
Figure 33.8. Timer 3 8-Bit Mode Block Diagram	508
Figure 33.9. Timer 3 Capture Mode Block Diagram	509
Figure 34.1. PCA Block Diagram	513
Figure 34.2. PCA Counter/Timer Block Diagram	515
Figure 34.3. PCA Interrupt Block Diagram	516
Figure 34.4. PCA Capture Mode Diagram	518
Figure 34.5. PCA Software Timer Mode Diagram	519
Figure 34.6. PCA High-Speed Output Mode Diagram	520
Figure 34.7. PCA Frequency Output Mode	521
Figure 34.8. PCA 8-Bit PWM Mode Diagram	522
Figure 34.9. PCA 9, 10 and 11-Bit PWM Mode Diagram	523
Figure 34.10. PCA 16-Bit PWM Mode	524
Figure 34.11. PCA Module 5 with Watchdog Timer Enabled	525
Figure 35.1. Typical C2 Pin Sharing	536

List of Tables

Table 2.1. Product Selection Guide	36
Table 3.1. Pin Definitions for the Si102x/3x	37
Table 3.2. LGA-85 Package Dimensions	46
Table 3.3. LGA-85 Land Pattern Dimensions	48
Table 4.1. Absolute Maximum Ratings	50
Table 4.2. Global Electrical Characteristics	51
Table 4.3. Digital Supply Current at VBAT pin with DC-DC Converter Enabled	51
Table 4.4. Digital Supply Current with DC-DC Converter Disabled	52
Table 4.5. Port I/O DC Electrical Characteristics	57
Table 4.6. Reset Electrical Characteristics	60
Table 4.7. Power Management Electrical Specifications	61
Table 4.8. Flash Electrical Characteristics	61
Table 4.9. Internal Precision Oscillator Electrical Characteristics	61
Table 4.10. Internal Low-Power Oscillator Electrical Characteristics	61
Table 4.11. SmaRTClock Characteristics	62
Table 4.12. ADC0 Electrical Characteristics	62
Table 4.13. Temperature Sensor Electrical Characteristics	63
Table 4.14. Voltage Reference Electrical Characteristics	64
Table 4.15. IREF0 Electrical Characteristics	65
Table 4.16. Comparator Electrical Characteristics	66
Table 4.17. VREG0 Electrical Characteristics	67
Table 4.18. LCD0 Electrical Characteristics	68
Table 4.19. PC0 Electrical Characteristics	68
Table 4.20. DC0 (Buck Converter) Electrical Characteristics	69
Table 4.21. DC Characteristics	70
Table 4.22. Synthesizer AC Electrical Characteristics	71
Table 4.23. Receiver AC Electrical Characteristics	72
Table 4.24. Transmitter AC Electrical Characteristics	73
Table 4.25. Auxiliary Block Specifications	74
Table 4.26. Digital IO Specifications (nIRQ)	75
Table 4.27. GPIO Specifications (GPIO_0, GPIO_1, and GPIO_2)	75
Table 4.28. Absolute Maximum Ratings	76
Table 5.1. Representative Conversion Times and Energy Consumption for the SAR ADC with 1.65 V High-Speed VREF	85
Table 8.1. CIP-51 Instruction Set Summary	117
Table 10.1. EMIF Pinout	132
Table 10.2. AC Parameters for External Memory Interface	146
Table 12.1. Example 16-bit CRC Outputs	162
Table 12.2. Example 32-bit CRC Outputs	164
Table 14.1. Extended Key Output Byte Order	183
Table 14.2. 192-Bit Key DMA Usage	184
Table 14.3. 256-bit Key DMA Usage	184

Si102x/3x

Table 15.1. Encoder Input and Output Data Sizes	208
Table 15.2. Manchester Encoding	209
Table 15.3. Manchester Decoding	210
Table 15.4. Three-out-of-Six Encoding Nibble	211
Table 15.5. Three-out-of-Six Decoding	212
Table 16.1. SFR Map (0xC0–0xFF)	228
Table 16.2. SFR Map (0x80–0xBF)	229
Table 16.3. Special Function Registers	230
Table 17.1. Interrupt Summary	240
Table 18.1. Flash Security Summary	254
Table 19.1. Power Modes	264
Table 20.1. IPEAK Inductor Current Limit Settings	277
Table 23.1. Recommended XFCN Settings for Crystal Mode	295
Table 23.2. Recommended XFCN Settings for RC and C modes	296
Table 24.1. SmARTClock Internal Registers	303
Table 24.2. SmARTClock Load Capacitance Settings	309
Table 24.3. SmARTClock Bias Settings	310
Table 25.1. Pull-Up Resistor Current	322
Table 25.2. Sample Rate Duty-Cycle Multiplier	322
Table 25.3. Pull-Up Duty-Cycle Multiplier	322
Table 25.4. Average Pull-Up Current (Sample Rate = 250 μ s)	323
Table 25.5. Average Pull-Up Current (Sample Rate = 500 μ s)	323
Table 25.6. Average Pull-Up Current (Sample Rate = 1 ms)	323
Table 25.7. Average Pull-Up Current (Sample Rate = 2 ms)	323
Table 26.1. Bit Configurations to select Contrast Control Modes	345
Table 27.1. Port I/O Assignment for Analog Functions	360
Table 27.2. Port I/O Assignment for Digital Functions	361
Table 27.3. Port I/O Assignment for External Digital Event Capture Functions	361
Table 28.1. SMBus Clock Source Selection	392
Table 28.2. Minimum SDA Setup and Hold Times	393
Table 28.3. Sources for Hardware Changes to SMB0CN	397
Table 28.4. Hardware Address Recognition Examples (EHACK = 1)	398
Table 28.5. SMBus Status Decoding With Hardware ACK Generation Disabled (EHACK = 0)	405
Table 28.6. SMBus Status Decoding With Hardware ACK Generation Enabled (EHACK = 1)	407
Table 29.1. Timer Settings for Standard Baud Rates Using The Internal 24.5 MHz Oscillator	416
Table 29.2. Timer Settings for Standard Baud Rates Using an External 22.1184 MHz Oscillator	416
Table 30.1. SPI Slave Timing Parameters	430
Table 31.1. SPI Timing Parameters	441
Table 32.1. EZRadioPRO Operating Modes	444
Table 32.2. EZRadioPRO Operating Modes Response Time	445

Table 32.3. Frequency Band Selection	450
Table 32.4. Packet Handler Registers	469
Table 32.5. Minimum Receiver Settling Time	471
Table 32.6. POR Parameters	474
Table 32.7. Temperature Sensor Range	477
Table 32.8. Antenna Diversity Control	483
Table 32.9. EZRadioPRO Internal Register Descriptions	488
Table 33.1. Timer 0 Running Modes	493
Table 34.1. PCA Timebase Input Options	514
Table 34.2. PCA0CPM and PCA0PWM Bit Settings for PCA Capture/Compare Modules	516
Table 34.3. Watchdog Timer Timeout Intervals1	526

List of Registers

SFR Definition 5.1. ADC0CN: ADC0 Control	86
SFR Definition 5.2. ADC0CF: ADC0 Configuration	87
SFR Definition 5.3. ADC0AC: ADC0 Accumulator Configuration	88
SFR Definition 5.4. ADC0PWR: ADC0 Burst Mode Power-Up Time	89
SFR Definition 5.5. ADC0TK: ADC0 Burst Mode Track Time	90
SFR Definition 5.6. ADC0H: ADC0 Data Word High Byte	91
SFR Definition 5.7. ADC0L: ADC0 Data Word Low Byte	91
SFR Definition 5.8. ADC0GTH: ADC0 Greater-Than High Byte	92
SFR Definition 5.9. ADC0GTL: ADC0 Greater-Than Low Byte	92
SFR Definition 5.10. ADC0LTH: ADC0 Less-Than High Byte	93
SFR Definition 5.11. ADC0LTL: ADC0 Less-Than Low Byte	93
SFR Definition 5.12. ADC0MX: ADC0 Input Channel Select	96
SFR Definition 5.13. TOFFH: Temperature Sensor Offset High Byte	99
SFR Definition 5.14. TOFFL: Temperature Sensor Offset Low Byte	99
SFR Definition 5.15. REF0CN: Voltage Reference Control	102
SFR Definition 6.1. CPT0CN: Comparator 0 Control	106
SFR Definition 6.2. CPT0MD: Comparator 0 Mode Selection	107
SFR Definition 6.3. CPT1CN: Comparator 1 Control	108
SFR Definition 6.4. CPT1MD: Comparator 1 Mode Selection	109
SFR Definition 7.1. IREF0CN: Current Reference Control	110
SFR Definition 7.2. IREF0CF: Current Reference Configuration	111
SFR Definition 7.3. CPT0MX: Comparator0 Input Channel Select	113
SFR Definition 7.4. CPT1MX: Comparator1 Input Channel Select	114
SFR Definition 8.1. DPL: Data Pointer Low Byte	121
SFR Definition 8.2. DPH: Data Pointer High Byte	121
SFR Definition 8.3. SP: Stack Pointer	122
SFR Definition 8.4. ACC: Accumulator	122
SFR Definition 8.5. B: B Register	122
SFR Definition 8.6. PSW: Program Status Word	123
SFR Definition 9.1. PSBANK: Program Space Bank Select	127
SFR Definition 10.1. EMI0CN: External Memory Interface Control	133
SFR Definition 10.2. EMI0CF: External Memory Configuration	134
SFR Definition 10.3. EMI0TC: External Memory Timing Control	139
SFR Definition 11.1. DMA0EN: DMA0 Channel Enable	151
SFR Definition 11.2. DMA0INT: DMA0 Full-Length Interrupt	152
SFR Definition 11.3. DMA0MINT: DMA0 Mid-Point Interrupt	153
SFR Definition 11.4. DMA0BUSY: DMA0 Busy	154
SFR Definition 11.5. DMA0SEL: DMA0 Channel Select for Configuration	155
SFR Definition 11.6. DMA0NMD: DMA Channel Mode	156
SFR Definition 11.7. DMA0NCF: DMA Channel Configuration	157
SFR Definition 11.8. DMA0NBAH: Memory Base Address High Byte	158
SFR Definition 11.9. DMA0NBAL: Memory Base Address Low Byte	158
SFR Definition 11.10. DMA0NAOH: Memory Address Offset High Byte	159

SFR Definition 11.11. DMA0NAOL: Memory Address Offset Low Byte	159
SFR Definition 11.12. DMA0NSZH: Transfer Size High Byte	160
SFR Definition 11.13. DMA0NSZL: Memory Transfer Size Low Byte	160
SFR Definition 12.1. CRC0CN: CRC0 Control	165
SFR Definition 12.2. CRC0IN: CRC0 Data Input	166
SFR Definition 12.3. CRC0DAT: CRC0 Data Output	166
SFR Definition 12.4. CRC0AUTO: CRC0 Automatic Control	167
SFR Definition 12.5. CRC0CNT: CRC0 Automatic Flash Sector Count	167
SFR Definition 12.6. CRC0FLIP: CRC0 Bit Flip	168
SFR Definition 13.1. CRC1CN: CRC1 Control	173
SFR Definition 13.2. CRC1IN: CRC1 Data IN	174
SFR Definition 13.3. CRC1POLL: CRC1 Polynomial LSB	174
SFR Definition 13.4. CRC1POLH: CRC1 Polynomial MSB	174
SFR Definition 13.5. CRC1OUTL: CRC1 Output LSB	175
SFR Definition 13.6. CRC1OUTH: CRC1 Output MSB	175
SFR Definition 14.1. AES0BCFG: AES Block Configuration	203
SFR Definition 14.2. AES0DCFG: AES Data Configuration	204
SFR Definition 14.3. AES0BIN: AES Block Input	205
SFR Definition 14.4. AES0XIN: AES XOR Input	206
SFR Definition 14.5. AES0KIN: AES Key Input	206
SFR Definition 14.6. AES0YOUT: AES Y Output	207
SFR Definition 15.1. ENC0CN: Encoder Decoder 0 Control	215
SFR Definition 15.2. ENC0L: ENC0 Data Low Byte	216
SFR Definition 15.3. ENC0M: ENC0 Data Middle Byte	216
SFR Definition 15.4. ENC0H: ENC0 Data High Byte	216
SFR Definition 16.1. SFRPGCN: SFR Page Control	224
SFR Definition 16.2. SFRPAGE: SFR Page	225
SFR Definition 16.3. SFRNEXT: SFR Next	226
SFR Definition 16.4. SFRLAST: SFR Last	227
SFR Definition 17.1. IE: Interrupt Enable	242
SFR Definition 17.2. IP: Interrupt Priority	243
SFR Definition 17.3. EIE1: Extended Interrupt Enable 1	244
SFR Definition 17.4. EIP1: Extended Interrupt Priority 1	245
SFR Definition 17.5. EIE2: Extended Interrupt Enable 2	246
SFR Definition 17.6. EIP2: Extended Interrupt Priority 2	247
SFR Definition 17.7. IT01CF: INT0/INT1 Configuration	249
SFR Definition 18.1. DEVICEID: Device Identification	255
SFR Definition 18.2. REVID: Revision Identification	256
SFR Definition 18.3. PSCTL: Program Store R/W Control	260
SFR Definition 18.4. FLKEY: Flash Lock and Key	261
SFR Definition 18.5. FLSCLE: Flash Scale	262
SFR Definition 18.6. FLWR: Flash Write Only	262
SFR Definition 18.7. FRBCN: Flash Read Buffer Control	263
SFR Definition 19.1. PCLKACT: Peripheral Active Clock Enable	267
SFR Definition 19.2. PCLKEN: Peripheral Clock Enable	268

Si102x/3x

SFR Definition 19.3. CLKMODE: Clock Mode	269
SFR Definition 19.4. PMU0CF: Power Management Unit Configuration	272
SFR Definition 19.5. PMU0FL: Power Management Unit Flag	273
SFR Definition 19.6. PMU0MD: Power Management Unit Mode	274
SFR Definition 19.7. PCON: Power Management Control Register	275
SFR Definition 20.1. DC0CN: DC-DC Converter Control	280
SFR Definition 20.2. DC0CF: DC-DC Converter Configuration	281
SFR Definition 20.3. DC0MD: DC-DC Converter Mode	282
SFR Definition 20.4. DC0RDY: DC-DC Converter Ready Indicator	283
SFR Definition 21.1. REG0CN: Voltage Regulator Control	284
SFR Definition 22.1. VDM0CN: VDD Supply Monitor Control	289
SFR Definition 22.2. RSTSRC: Reset Source	292
SFR Definition 23.1. CLKSEL: Clock Select	298
SFR Definition 23.2. OSCICN: Internal Oscillator Control	299
SFR Definition 23.3. OSCICL: Internal Oscillator Calibration	300
SFR Definition 23.4. OSCXCN: External Oscillator Control	301
SFR Definition 24.1. RTC0KEY: SmarTclock Lock and Key	305
SFR Definition 24.2. RTC0ADR: SmarTclock Address	305
SFR Definition 24.3. RTC0DAT: SmarTclock Data	306
Internal Register Definition 24.4. RTC0CN: SmarTclock Control	313
Internal Register Definition 24.5. RTC0XCN: SmarTclock Oscillator Control	314
Internal Register Definition 24.6. RTC0XCF: SmarTclock Oscillator Configuration	315
Internal Register Definition 24.7. RTC0CF: SmarTclock Configuration	316
Internal Register Definition 24.8. CAPTUREn: SmarTclock Timer Capture	317
Internal Register Definition 24.9. ALARM0Bn: SmarTclock Alarm 0 Match Value	317
Internal Register Definition 24.10. ALARM1Bn: SmarTclock Alarm 1 Match Value	318
Internal Register Definition 24.11. ALARM2Bn: SmarTclock Alarm 2 Match Value	318
SFR Definition 25.1. PC0MD: PC0 Mode Configuration	328
SFR Definition 25.2. PC0PCF: PC0 Mode Pull-Up Configuration	329
SFR Definition 25.3. PC0TH: PC0 Threshold Configuration	330
SFR Definition 25.4. PC0STAT: PC0 Status	331
SFR Definition 25.5. PC0DCH: PC0 Debounce Configuration High	332
SFR Definition 25.6. PC0DCL: PC0 Debounce Configuration Low	333
SFR Definition 25.7. PC0CTR0H: PC0 Counter 0 High (MSB)	334
SFR Definition 25.8. PC0CTR0M: PC0 Counter 0 Middle	334
SFR Definition 25.9. PC0CTR0L: PC0 Counter 0 Low (LSB)	334
SFR Definition 25.10. PC0CTR1H: PC0 Counter 1 High (MSB)	335
SFR Definition 25.11. PC0CTR1M: PC0 Counter 1 Middle	335
SFR Definition 25.12. PC0CTR1L: PC0 Counter 1 Low (LSB)	335
SFR Definition 25.13. PC0CMP0H: PC0 Comparator 0 High (MSB)	336
SFR Definition 25.14. PC0CMP0M: PC0 Comparator 0 Middle	336

SFR Definition 25.15. PC0CMP0L: PC0 Comparator 0 Low (LSB)	336
SFR Definition 25.16. PC0CMP1H: PC0 Comparator 1 High (MSB)	337
SFR Definition 25.17. PC0CMP1M: PC0 Comparator 1 Middle	337
SFR Definition 25.18. PC0CMP1L: PC0 Comparator 1 Low (LSB)	337
SFR Definition 25.19. PC0HIST: PC0 History	338
SFR Definition 25.20. PC0INT0: PC0 Interrupt 0	339
SFR Definition 25.21. PC0INT1: PC0 Interrupt 1	340
SFR Definition 26.1. LCD0Dn: LCD0 Data	342
SFR Definition 26.2. LCD0CN: LCD0 Control Register	344
SFR Definition 26.3. LCD0CNTRST: LCD0 Contrast Adjustment	348
SFR Definition 26.4. LCD0MSCN: LCD0 Master Control	349
SFR Definition 26.5. LCD0MSCF: LCD0 Master Configuration	350
SFR Definition 26.6. LCD0PWR: LCD0 Power	350
SFR Definition 26.7. LCD0VBM CN: LCD0 VBAT Monitor Control	351
SFR Definition 26.8. LCD0CLKDIVH: LCD0 Refresh Rate Prescaler High Byte	352
SFR Definition 26.9. LCD0CLKDIVL: LCD Refresh Rate Prescaler Low Byte	352
SFR Definition 26.10. LCD0BLINK: LCD0 Blink Mask	353
SFR Definition 26.11. LCD0TOGR: LCD0 Toggle Rate	354
SFR Definition 26.12. LCD0CF: LCD0 Configuration	355
SFR Definition 26.13. LCD0CHPCN: LCD0 Charge Pump Control	355
SFR Definition 26.14. LCD0CHPCF: LCD0 Charge Pump Configuration	356
SFR Definition 26.15. LCD0CHPMD: LCD0 Charge Pump Mode	356
SFR Definition 26.16. LCD0BUFCN: LCD0 Buffer Control	356
SFR Definition 26.17. LCD0BUFCF: LCD0 Buffer Configuration	357
SFR Definition 26.18. LCD0BUFMD: LCD0 Buffer Mode	357
SFR Definition 26.19. LCD0VBMCF: LCD0 VBAT Monitor Configuration	357
SFR Definition 27.1. XBR0: Port I/O Crossbar Register 0	365
SFR Definition 27.2. XBR1: Port I/O Crossbar Register 1	366
SFR Definition 27.3. XBR2: Port I/O Crossbar Register 2	367
SFR Definition 27.4. P0MASK: Port0 Mask Register	368
SFR Definition 27.5. P0MAT: Port0 Match Register	368
SFR Definition 27.6. P1MASK: Port1 Mask Register	369
SFR Definition 27.7. P1MAT: Port1 Match Register	369
SFR Definition 27.8. P0: Port0	371
SFR Definition 27.9. P0SKIP: Port0 Skip	371
SFR Definition 27.10. P0MDIN: Port0 Input Mode	372
SFR Definition 27.11. P0MDOUT: Port0 Output Mode	372
SFR Definition 27.12. P0DRV: Port0 Drive Strength	373
SFR Definition 27.13. P1: Port1	373
SFR Definition 27.14. P1SKIP: Port1 Skip	374
SFR Definition 27.15. P1MDIN: Port1 Input Mode	374
SFR Definition 27.16. P1MDOUT: Port1 Output Mode	375
SFR Definition 27.17. P1DRV: Port1 Drive Strength	375
SFR Definition 27.18. P2: Port2	376
SFR Definition 27.19. P2SKIP: Port2 Skip	376

Si102x/3x

SFR Definition 27.20. P2MDIN: Port2 Input Mode	377
SFR Definition 27.21. P2MDOUT: Port2 Output Mode	377
SFR Definition 27.22. P2DRV: Port2 Drive Strength	378
SFR Definition 27.23. P3: Port3	378
SFR Definition 27.24. P3MDIN: Port3 Input Mode	379
SFR Definition 27.25. P3MDOUT: Port3 Output Mode	379
SFR Definition 27.26. P3DRV: Port3 Drive Strength	380
SFR Definition 27.27. P4: Port4	380
SFR Definition 27.28. P4MDIN: Port4 Input Mode	381
SFR Definition 27.29. P4MDOUT: Port4 Output Mode	381
SFR Definition 27.30. P4DRV: Port4 Drive Strength	382
SFR Definition 27.31. P5: Port5	382
SFR Definition 27.32. P5MDIN: Port5 Input Mode	383
SFR Definition 27.33. P5MDOUT: Port5 Output Mode	383
SFR Definition 27.34. P5DRV: Port5 Drive Strength	384
SFR Definition 27.35. P6: Port6	384
SFR Definition 27.36. P6MDIN: Port6 Input Mode	385
SFR Definition 27.37. P6MDOUT: Port6 Output Mode	385
SFR Definition 27.38. P6DRV: Port6 Drive Strength	386
SFR Definition 27.39. P7: Port7	386
SFR Definition 27.40. P7MDOUT: Port7 Output Mode	387
SFR Definition 27.41. P7DRV: Port7 Drive Strength	387
SFR Definition 28.1. SMB0CF: SMBus Clock/Configuration	394
SFR Definition 28.2. SMB0CN: SMBus Control	396
SFR Definition 28.3. SMB0ADR: SMBus Slave Address	398
SFR Definition 28.4. SMB0ADM: SMBus Slave Address Mask	399
SFR Definition 28.5. SMB0DAT: SMBus Data	400
SFR Definition 29.1. SCON0: Serial Port 0 Control	414
SFR Definition 29.2. SBUF0: Serial (UART0) Port Data Buffer	415
SFR Definition 30.1. SPI0CFG: SPI0 Configuration	425
SFR Definition 30.2. SPI0CN: SPI0 Control	426
SFR Definition 30.3. SPI0CKR: SPI0 Clock Rate	427
SFR Definition 30.4. SPI0DAT: SPI0 Data	427
SFR Definition 31.1. SPI1CFG: SPI1 Configuration	438
SFR Definition 31.2. SPI1CN: SPI1 Control	439
SFR Definition 31.3. SPI1CKR: SPI1 Clock Rate	440
SFR Definition 31.4. SPI1DAT: SPI1 Data	440
SFR Definition 33.1. CKCON: Clock Control	492
SFR Definition 33.2. TCON: Timer Control	497
SFR Definition 33.3. TMOD: Timer Mode	498
SFR Definition 33.4. TL0: Timer 0 Low Byte	499
SFR Definition 33.5. TL1: Timer 1 Low Byte	499
SFR Definition 33.6. TH0: Timer 0 High Byte	500
SFR Definition 33.7. TH1: Timer 1 High Byte	500
SFR Definition 33.8. TMR2CN: Timer 2 Control	504

SFR Definition 33.9. TMR2RLL: Timer 2 Reload Register Low Byte	505
SFR Definition 33.10. TMR2RLH: Timer 2 Reload Register High Byte	505
SFR Definition 33.11. TMR2L: Timer 2 Low Byte	506
SFR Definition 33.12. TMR2H: Timer 2 High Byte	506
SFR Definition 33.13. TMR3CN: Timer 3 Control	510
SFR Definition 33.14. TMR3RLL: Timer 3 Reload Register Low Byte	511
SFR Definition 33.15. TMR3RLH: Timer 3 Reload Register High Byte	511
SFR Definition 33.16. TMR3L: Timer 3 Low Byte	512
SFR Definition 33.17. TMR3H: Timer 3 High Byte	512
SFR Definition 34.1. PCA0CN: PCA Control	527
SFR Definition 34.2. PCA0MD: PCA Mode	528
SFR Definition 34.3. PCA0PWM: PCA PWM Configuration	529
SFR Definition 34.4. PCA0CPMn: PCA Capture/Compare Mode	530
SFR Definition 34.5. PCA0L: PCA Counter/Timer Low Byte	531
SFR Definition 34.6. PCA0H: PCA Counter/Timer High Byte	531
SFR Definition 34.7. PCA0CPLn: PCA Capture Module Low Byte	532
SFR Definition 34.8. PCA0CPHn: PCA Capture Module High Byte	532
C2 Register Definition 35.1. C2ADD: C2 Address	533
C2 Register Definition 35.2. DEVICEID: C2 Device ID	534
C2 Register Definition 35.3. REVID: C2 Revision ID	534
C2 Register Definition 35.4. FPCTL: C2 Flash Programming Control	535
C2 Register Definition 35.5. FPDAT: C2 Flash Programming Data	535

Si102x/3x

1. System Overview

Si102x/3x devices are fully integrated mixed-signal System-on-a-Chip MCUs. Highlighted features are listed below. Refer to Table 2.1 for specific product feature selection and part ordering numbers.

- 240-960 MHz EZRadioPRO(R) transceiver
- Power efficient on-chip dc-dc buck converter
- High-speed pipelined 8051-compatible microcontroller core (up to 25 MIPS)
- In-system, full-speed, non-intrusive debug interface (on-chip)
- True 10-bit 300 ksps, or 12-bit 75 ksps single-ended ADC with 16 external analog inputs and 4 internal inputs such as various power supply voltages and the temperature sensor
- 6-bit programmable current reference
- Precision programmable 24.5 MHz internal oscillator with spread spectrum technology
- 128 kB, 64 kB, 32 kB, or 16 kB of on-chip flash memory
- 8448 or 4352 bytes of on-chip RAM
- 128 segment LCD driver
- SMBus/I²C, enhanced UART, and two enhanced SPI serial interfaces implemented in hardware
- Four general-purpose 16-bit timers
- Programmable counter/timer array (PCA) with six capture/compare modules and watchdog timer function
- Hardware AES, DMA, and pulse counter
- On-chip power-on reset, V_{DD} monitor, and temperature sensor
- Two on-chip voltage comparators
- 53-port I/O

With on-chip power-on reset, V_{DD} monitor, watchdog timer, and clock oscillator, the Si102x/3x devices are truly stand-alone system-on-a-chip solutions. The flash memory can be reprogrammed even in-circuit, providing non-volatile data storage, and also allowing field upgrades of the 8051 firmware. User software has complete control of all peripherals, and may individually shut down any or all peripherals for power savings.

The on-chip Silicon Labs 2-wire (C2) development interface allows non-intrusive (uses no on-chip resources), full speed, in-circuit debugging using the production MCU installed in the final application. This debug logic supports inspection and modification of memory and registers, setting breakpoints, single stepping, run and halt commands. All analog and digital peripherals are fully functional while debugging using C2. The two C2 interface pins can be shared with user functions, allowing in-system debugging without occupying package pins.

Each device is specified for 1.8 to 3.8 V operation over the industrial temperature range (–40 to +85 °C). The port I/O and RST pins are tolerant of input signals up to V_{IO} + 2.0 V. The Si102x/3x devices are available in an 85-pin LGA package that is lead-free and RoHS-compliant. See Table 2.1 for ordering information. Block diagrams are included in Figure 1.1 and Figure 1.2.

The transceiver's extremely low receive sensitivity (–121 dBm) coupled with industry leading +13 or +20 dBm output power ensures extended range and improved link performance. Built-in antenna diversity and support for frequency hopping can be used to further extend range and enhance performance. The advanced radio features including continuous frequency coverage from 240–960 MHz in 156 Hz or 312 Hz steps allow precise tuning control. Additional system features such as an automatic wake-up timer, low battery detector, 64 byte TX/RX FIFOs, automatic packet handling, and preamble detection reduce overall current consumption.

The transceivers digital receive architecture features a high-performance ADC and DSP-based modem which performs demodulation, filtering, and packet handling for increased flexibility and performance. The direct digital transmit modulation and automatic PA power ramping ensure precise transmit modulation and reduced spectral spreading, ensuring compliance with global regulations including FCC, ETSI, ARIB, and 802.15.4d.

Si102x/3x

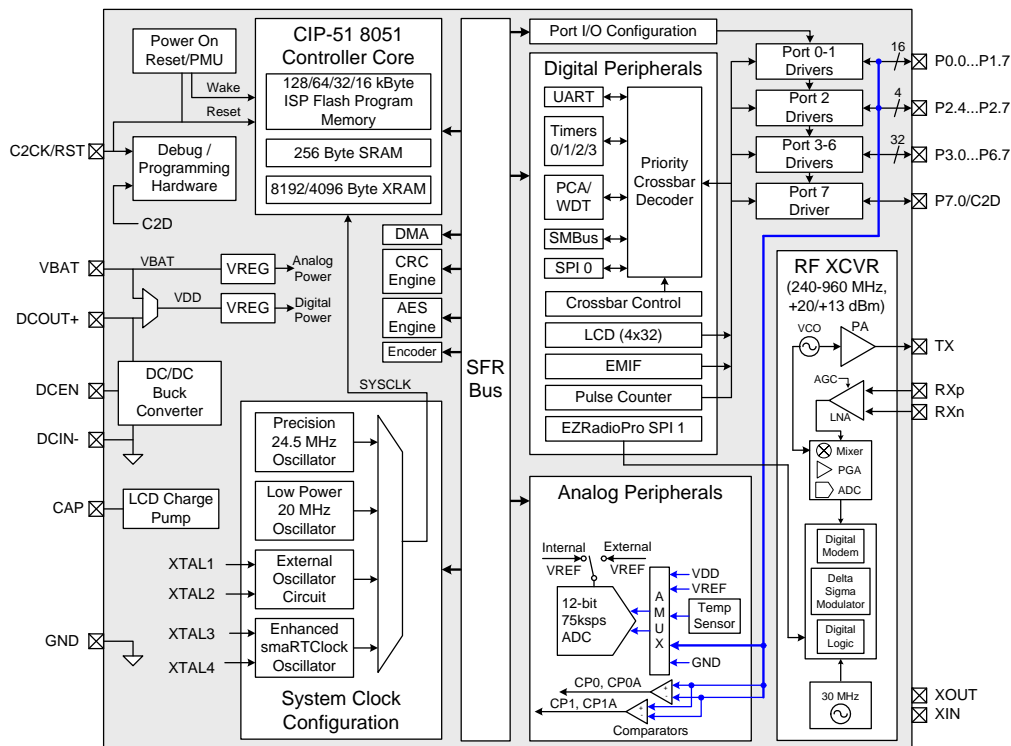

Figure 1.1. Si102x Block Diagram

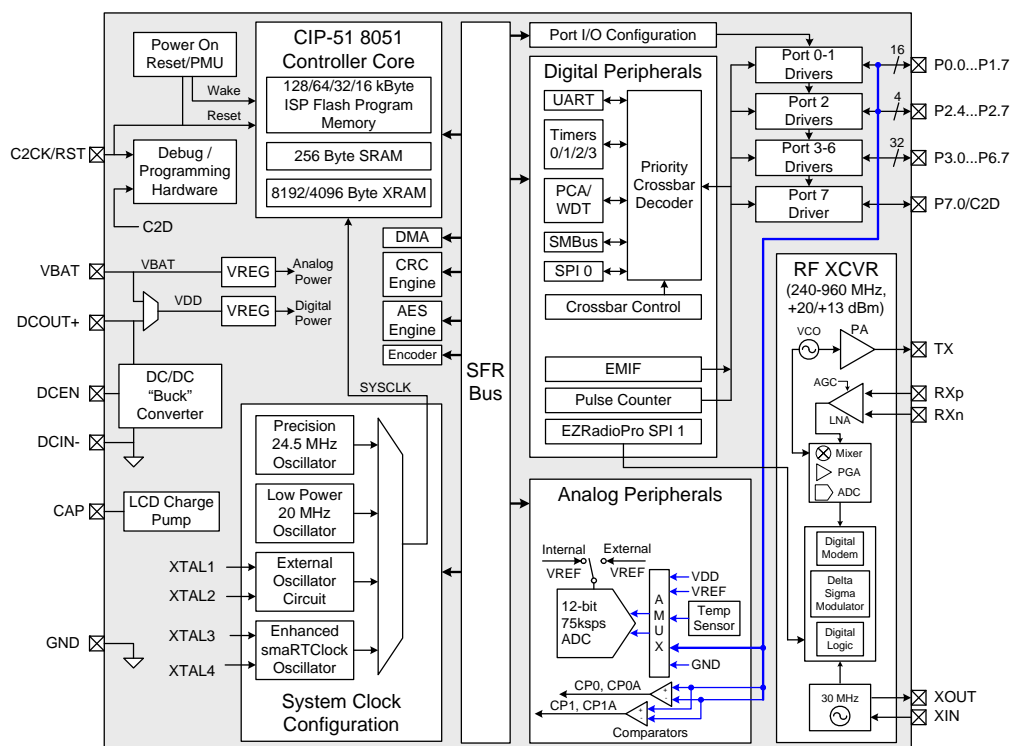

Figure 1.2. Si103x Block Diagram

1.1. Typical Connection Diagram

The application shown in Figure 1.7 is designed for a system with a TX/RX direct-tie configuration without the use of a TX/RX switch. Most lower power applications will use this configuration. A complete direct-tie reference design is available from Silicon Laboratories applications support.

For applications seeking improved performance in the presence of multipath fading, antenna diversity can be used. Antenna diversity support is integrated into the EZRadioPRO transceiver and can improve the system link budget by 8–10 dB in the presence of these fading conditions, resulting in substantial range increases. A complete Antenna Diversity reference design is available from Silicon Laboratories applications support.

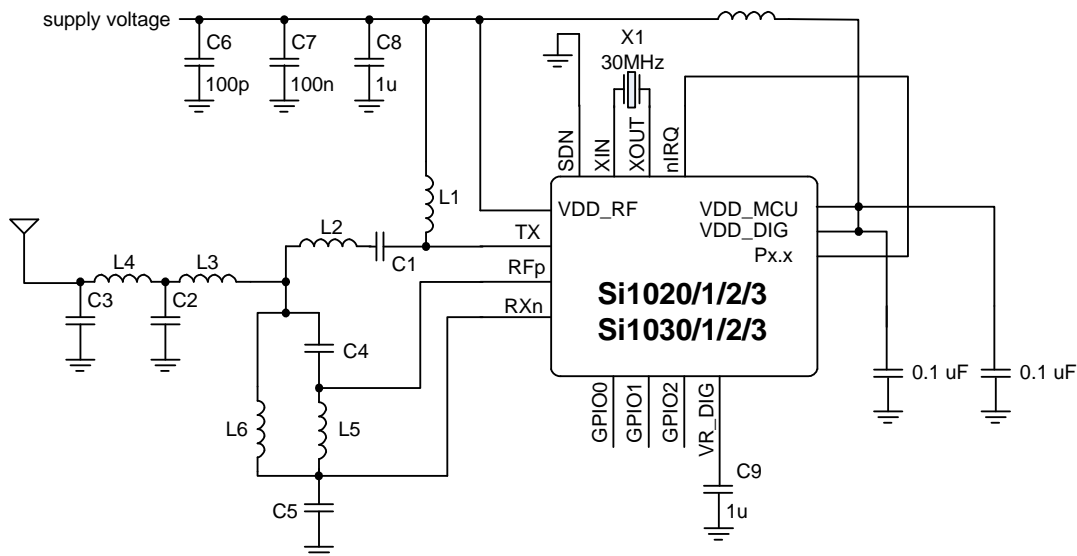

Figure 1.3. Si102x/3x RX/TX Direct-tie Application Example

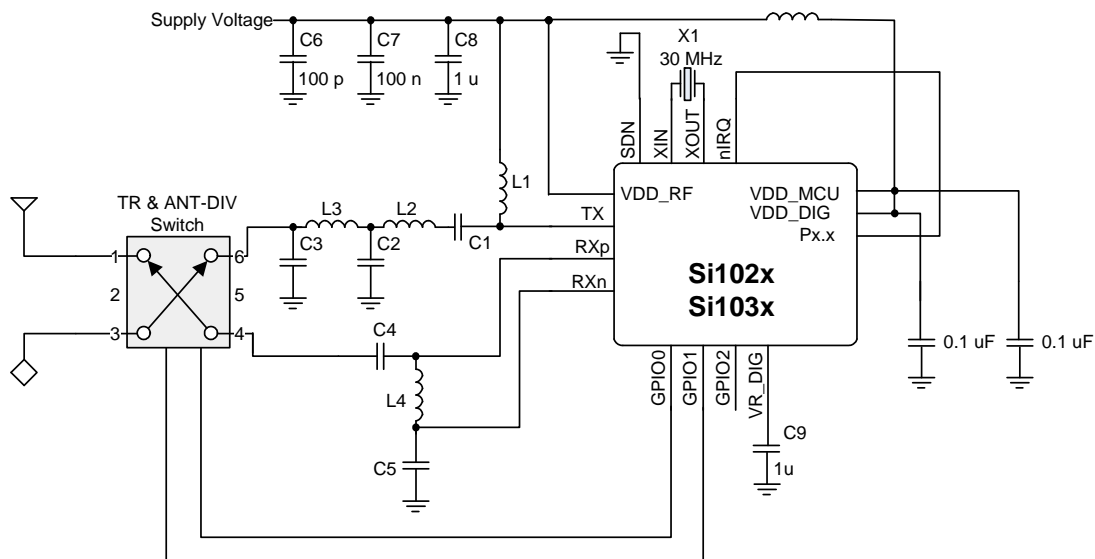

Figure 1.4. Si102x/3x Antenna Diversity Application Example

Si102x/3x

1.2. CIP-51™ Microcontroller Core

1.2.1. Fully 8051 Compatible

The Si102x/3x family utilizes Silicon Labs' proprietary CIP-51 microcontroller core. The CIP-51 is fully compatible with the MCS-51™ instruction set; standard 803x/805x assemblers and compilers can be used to develop software. The CIP-51 core offers all the peripherals included with a standard 8052.

1.2.2. Improved Throughput

The CIP-51 employs a pipelined architecture that greatly increases its instruction throughput over the standard 8051 architecture. In a standard 8051, all instructions except for MUL and DIV take 12 or 24 system clock cycles to execute with a maximum system clock of 12-to-24 MHz. By contrast, the CIP-51 core executes 70% of its instructions in one or two system clock cycles, with only four instructions taking more than four system clock cycles.

The CIP-51 has a total of 109 instructions. The table below shows the total number of instructions that require each execution time.

Clocks to Execute	1	2	2/3	3	3/4	4	4/5	5	8
Number of Instructions	26	50	5	14	7	3	1	2	1

With the CIP-51's maximum system clock at 25 MHz, it has a peak throughput of 25 MIPS.

1.2.3. Additional Features

The Si102x/3x SoC family includes several key enhancements to the CIP-51 core and peripherals to improve performance and ease of use in end applications.

The extended interrupt handler provides multiple interrupt sources into the CIP-51 allowing numerous analog and digital peripherals to interrupt the controller. An interrupt driven system requires less intervention by the MCU, giving it more effective throughput. The extra interrupt sources are very useful when building multi-tasking, real-time systems.

Eight reset sources are available: power-on reset circuitry (POR), an on-chip V_{DD} monitor (forces reset when power supply voltage drops below safe levels), a Watchdog Timer, a Missing Clock Detector, SmaRTClock oscillator fail or alarm, a voltage level detection from Comparator0, a forced software reset, an external reset pin, and an illegal flash access protection circuit. Each reset source except for the POR, Reset Input Pin, or flash error may be disabled by the user in software. The WDT may be permanently disabled in software after a power-on reset during MCU initialization.

The internal oscillator factory calibrated to 24.5 MHz and is accurate to $\pm 2\%$ over the full temperature and supply range. The internal oscillator period can also be adjusted by user firmware. An additional 20 MHz low power oscillator is also available which facilitates low-power operation. An external oscillator drive circuit is included, allowing an external crystal, ceramic resonator, capacitor, RC, or CMOS clock source to generate the system clock. If desired, the system clock source may be switched on-the-fly between both internal and external oscillator circuits. An external oscillator can also be extremely useful in low power applications, allowing the MCU to run from a slow (power saving) source, while periodically switching to the fast (up to 25 MHz) internal oscillator as needed.

1.3. Port Input/Output

Digital and analog resources are available through 53 I/O pins. Port pins are organized as eight byte-wide ports. Port pins can be defined as digital or analog I/O. Digital I/O pins can be assigned to one of the internal digital resources or used as general purpose I/O (GPIO). Analog I/O pins are used by the internal analog resources. P7.0 can be used as GPIO and is shared with the C2 Interface Data signal (C2D). See Section “35. C2 Interface” on page 533 for more details.

The designer has complete control over which digital and analog functions are assigned to individual port pins. This resource assignment flexibility is achieved through the use of a Priority Crossbar Decoder. See Section “27. Port Input/Output” on page 358 for more information on the Crossbar.

For Port I/Os configured as push-pull outputs, current is sourced from the VIO, VIORF, or VBAT supply pin. Port I/Os used for analog functions can operate up to the supply voltage. See Section “27. Port Input/Output” on page 358 for more information on Port I/O operating modes and the electrical specifications chapter for detailed electrical specifications.

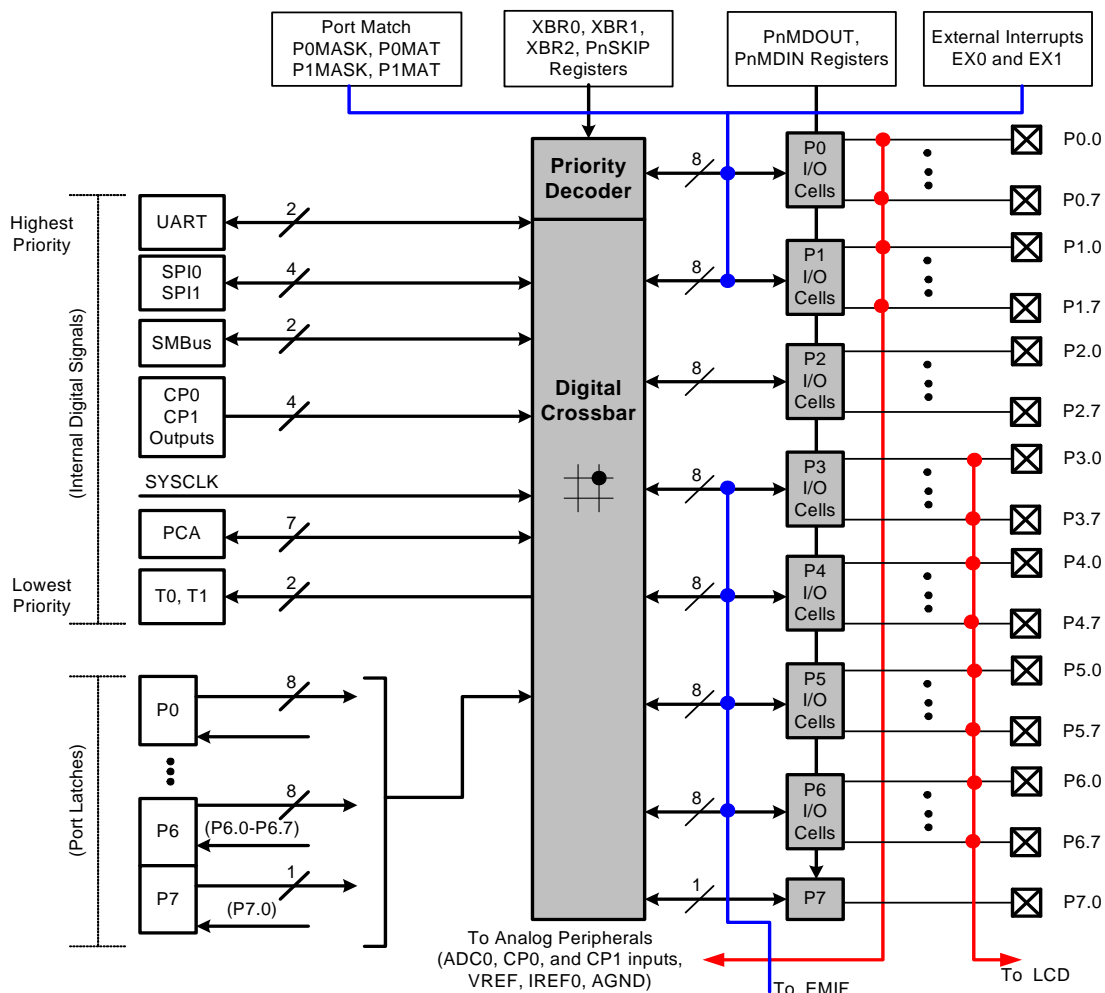

Figure 1.5. Port I/O Functional Block Diagram

Si102x/3x

1.4. Serial Ports

The Si102x/3x Family includes an SMBus/I²C interface, a full-duplex UART with enhanced baud rate configuration, and two Enhanced SPI interfaces. Each of the serial buses is fully implemented in hardware and makes extensive use of the CIP-51's interrupts, thus requiring very little CPU intervention.

1.5. Programmable Counter Array

An on-chip Programmable Counter/Timer Array (PCA) is included in addition to the four 16-bit general purpose counter/timers. The PCA consists of a dedicated 16-bit counter/timer time base with six programmable capture/compare modules. The PCA clock is derived from one of six sources: the system clock divided by 12, the system clock divided by 4, Timer 0 overflows, an External Clock Input (ECI), the system clock, or the external oscillator clock source divided by 8.

Each capture/compare module can be configured to operate in a variety of modes: edge-triggered capture, software timer, high-speed output, pulse width modulator (8, 9, 10, 11, or 16-bit), or frequency output. Additionally, Capture/Compare Module 5 offers watchdog timer (WDT) capabilities. Following a system reset, Module 5 is configured and enabled in WDT mode. The PCA Capture/Compare Module I/O and External Clock Input may be routed to Port I/O via the Digital Crossbar.

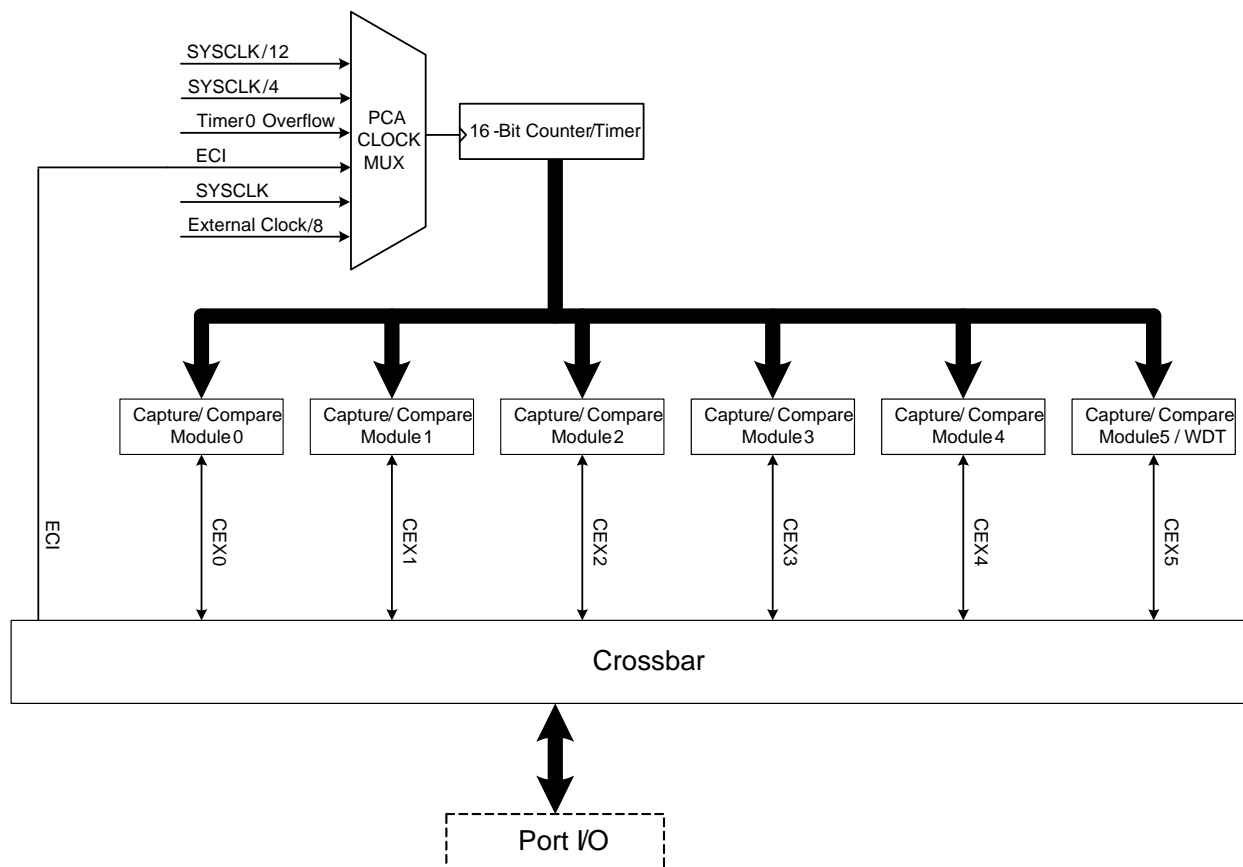

Figure 1.6. PCA Block Diagram

1.6. SAR ADC with 16-bit Auto-Averaging Accumulator and Autonomous Low Power Burst Mode

The ADC0 on Si102x/3x devices is a 300 kbps, 10-bit or 75 kbps, 12-bit successive-approximation-register (SAR) ADC with integrated track-and-hold and programmable window detector. ADC0 also has an autonomous low power Burst Mode which can automatically enable ADC0, capture and accumulate samples, then place ADC0 in a low power shutdown mode without CPU intervention. It also has a 16-bit accumulator that can automatically oversample and average the ADC results. See Section “5.4. 12-Bit Mode” on page 84 for more details on using the ADC in 12-bit mode.

The ADC is fully configurable under software control via Special Function Registers. The ADC0 operates in single-ended mode and may be configured to measure various different signals using the analog multiplexer described in Section “5.7. ADC0 Analog Multiplexer” on page 95. The voltage reference for the ADC is selected as described in Section “5.9. Voltage and Ground Reference Options” on page 100.

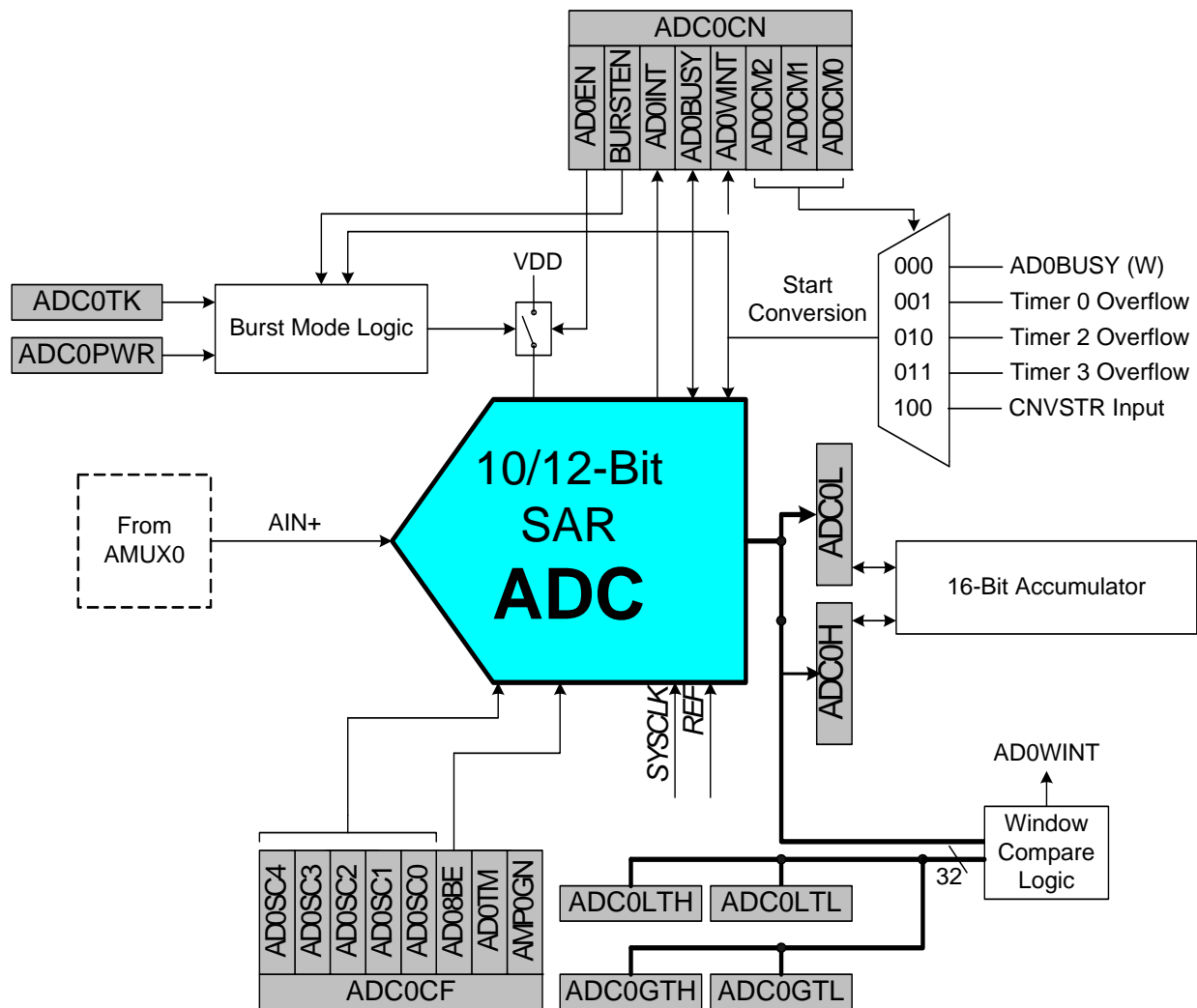

Figure 1.7. ADC0 Functional Block Diagram

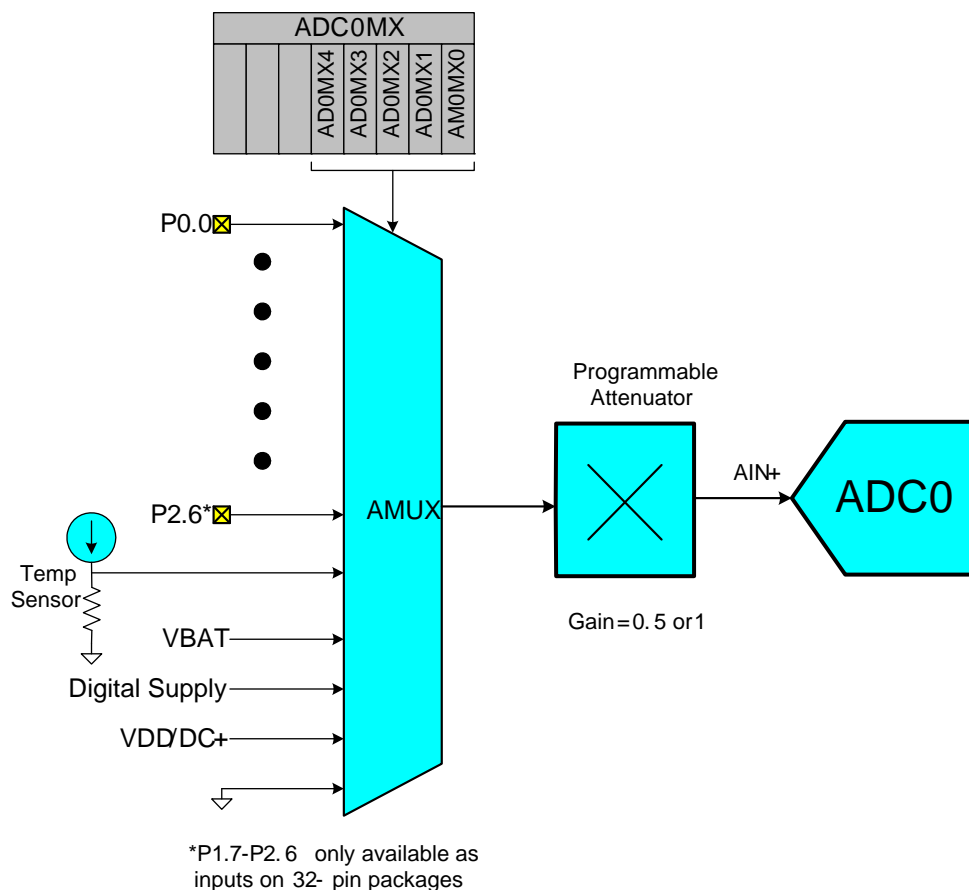

Figure 1.8. ADC0 Multiplexer Block Diagram

1.7. Programmable Current Reference (IREF0)

Si102x/3x devices include an on-chip programmable current reference (source or sink) with two output current settings: low power mode and high current mode. The maximum current output in low power mode is 63 μA (1 μA steps) and the maximum current output in high current mode is 504 μA (8 μA steps).

1.8. Comparators

Si102x/3x devices include two on-chip programmable voltage comparators: Comparator 0 (CPT0) which is shown in Figure 1.9; Comparator 1 (CPT1) which is shown in Figure 1.10. The two comparators operate identically but may differ in their ability to be used as reset or wake-up sources. See Section “22. Reset Sources” on page 285 and the Section “19. Power Management” on page 264 for details on reset sources and low power mode wake-up sources, respectively.

The comparator offers programmable response time and hysteresis, an analog input multiplexer, and two outputs that are optionally available at the Port pins: a synchronous “latched” output (CP0, CP1), or an asynchronous “raw” output (CP0A, CP1A). The asynchronous CP0A signal is available even when the system clock is not active. This allows the Comparator to operate and generate an output when the device is in some low power modes.

The comparator inputs may be connected to Port I/O pins or to other internal signals.

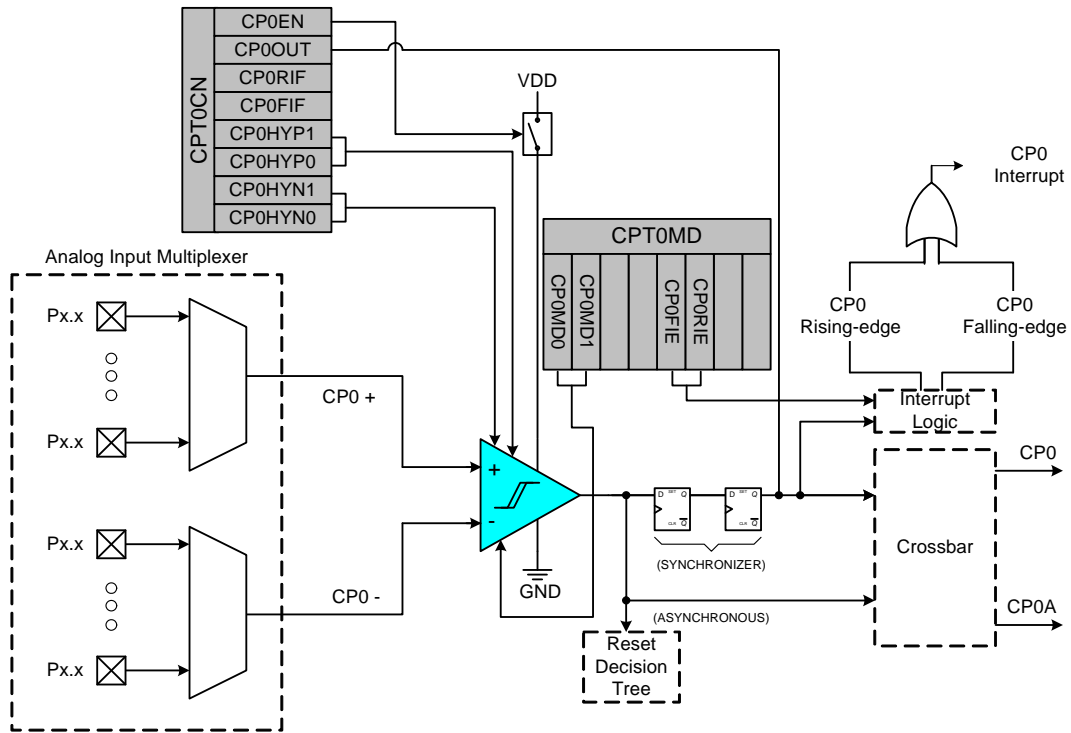

Figure 1.9. Comparator 0 Functional Block Diagram

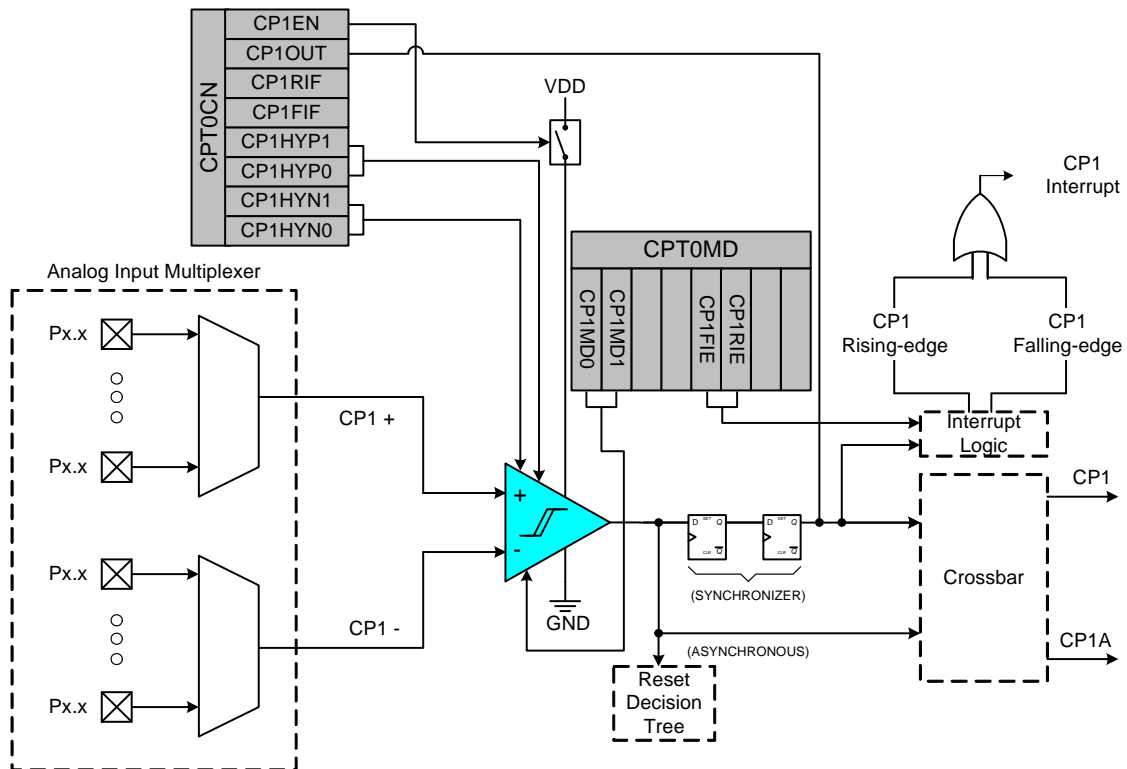

Figure 1.10. Comparator 1 Functional Block Diagram

Si102x/3x

2. Ordering Information

Table 2.1. Product Selection Guide

Ordering Part Number	MIPS (Peak)	Flash Memory (kB)	RAM (bytes)	TX Output Power (dBm)	LCD Segments (4-MUX)	Digital Port I/Os	AES 128, 192, 256 Encryption	SmaRTClock Real Time Clock	SMBus/I ² C	UART	Enhanced SPI	Timers (16-bit)	PCA Channels	10/12-bit 300/75 ksps ADC channels with internal VREF and temp sensor	Analog Comparators	Package
Si1020-A-GM	25	128	8448	20	128	53	✓	✓	1	1	2	4	6	16	2	LGA-85 (6x8)
Si1021-A-GM	25	64	8448	20	128	53	✓	✓	1	1	2	4	6	16	2	LGA-85 (6x8)
Si1022-A-GM	25	32	8448	20	128	53	✓	✓	1	1	2	4	6	16	2	LGA-85 (6x8)
Si1023-A-GM	25	16	4352	20	128	53	✓	✓	1	1	2	4	6	16	2	LGA-85 (6x8)
Si1024-A-GM	25	128	8448	13	128	53	✓	✓	1	1	2	4	6	16	2	LGA-85 (6x8)
Si1025-A-GM	25	64	8448	13	128	53	✓	✓	1	1	2	4	6	16	2	LGA-85 (6x8)
Si1026-A-GM	25	32	8448	13	128	53	✓	✓	1	1	2	4	6	16	2	LGA-85 (6x8)
Si1027-A-GM	25	16	4352	13	128	53	✓	✓	1	1	2	4	6	16	2	LGA-85 (6x8)
Si1030-A-GM	25	128	8448	20	—	53	✓	✓	1	1	2	4	6	16	2	LGA-85 (6x8)
Si1031-A-GM	25	64	8448	20	—	53	✓	✓	1	1	2	4	6	16	2	LGA-85 (6x8)
Si1032-A-GM	25	32	8448	20	—	53	✓	✓	1	1	2	4	6	16	2	LGA-85 (6x8)
Si1033-A-GM	25	16	4352	20	—	53	✓	✓	1	1	2	4	6	16	2	LGA-85 (6x8)
Si1034-A-GM	25	128	8448	13	—	53	✓	✓	1	1	2	4	6	16	2	LGA-85 (6x8)
Si1035-A-GM	25	64	8448	13	—	53	✓	✓	1	1	2	4	6	16	2	LGA-85 (6x8)
Si1036-A-GM	25	32	8448	13	—	53	✓	✓	1	1	2	4	6	16	2	LGA-85 (6x8)
Si1037-A-GM	25	16	4352	13	—	53	✓	✓	1	1	2	4	6	16	2	LGA-85 (6x8)

All packages are lead-free (RoHS Compliant).

3. Pinout and Package Definitions

Table 3.1. Pin Definitions for the Si102x/3x

Name	Pin Number	Type	Description
VBAT	A43	P In	Battery Supply Voltage. Must be 1.8 to 3.8 V.
VBATDC	A44	P In	DC0 Input Voltage. Must be 1.8 to 3.8 V.
VDC	A46	P In	Alternate Power Supply Voltage. Must be 1.8 to 3.6 V. This supply voltage must always be \leq VBAT. Software may select this supply voltage to power the digital logic.
		P Out	Positive output of the DC-DC converter. A 1 uF to 10 uF ceramic capacitor is required on this pin when using the DC-DC converter. This pin can supply power to external devices when the DC-DC converter is enabled.
GNDDC	A45	P In	DC-DC converter return current path. This pin is typically tied to the ground plane.
GND	D2	G	Required Ground.
GND	D6	G	Required Ground.
GND	B16	G	Required Ground.
GND	B17	G	Required Ground.
GND	A32	G	Required Ground.
GND	B28	G	Required Ground.
IND	B27	P In	DC-DC Inductor Pin. This pin requires a 560 nH inductor to VDC if the DC-DC converter is used.
VIO	B26	P In	I/O Power Supply for P0.0–P1.4 and P2.4–P7.0 pins. This supply voltage must always be \leq VBAT.
VIORF	B29	P In	I/O Power Supply for P1.5–P2.3 pins. This supply voltage must always be \leq VBAT
RST/ C2CK	A47	D I/O	Device Reset. Open-drain output of internal POR or V_{DD} monitor. An external source can initiate a system reset by driving this pin low for at least 15 μ s. A 1 k Ω to 5 k Ω pullup to V_{DD} is recommended. See Reset Sources Section for a complete description. Clock signal for the C2 Debug Interface.
C2CK		D I/O	
P7.0/ C2D	A48	D I/O	Port 7.0. This pin can only be used as GPIO. The Crossbar cannot route signals to this pin and it cannot be configured as an analog input. See Port I/O Section for a complete description. Bi-directional data signal for the C2 Debug Interface.
C2D		D I/O	

Si102x/3x

Table 3.1. Pin Definitions for the Si102x/3x (Continued)

Name	Pin Number	Type	Description
VLCD	A29	P I/O	LCD Power Supply. This pin requires a 10 μ F capacitor to stabilize the charge pump.
P0.0	A42	D I/O or A In	Port 0.0. See Port I/O Section for a complete description.
V _{REF}		A In A Out	External V _{REF} Input. Internal V _{REF} Output. External V _{REF} decoupling capacitors are recommended. See ADC0 Section for details.
P0.1	A41	D I/O or A In	Port 0.1. See Port I/O Section for a complete description.
AGND		G	Optional Analog Ground. See ADC0 Section for details.
P0.2	A40	D I/O or A In	Port 0.2. See Port I/O Section for a complete description.
XTAL1		A In	External Clock Input. This pin is the external oscillator return for a crystal or resonator. See Oscillator Section.
P0.3	A39	D I/O or A In	Port 0.3. See Port I/O Section for a complete description.
XTAL2		A Out D In A In	External Clock Output. This pin is the excitation driver for an external crystal or resonator. External Clock Input. This pin is the external clock input in external CMOS clock mode. External Clock Input. This pin is the external clock input in capacitor or RC oscillator configurations. See Oscillator Section for complete details.
P0.4	A38	D I/O or A In	Port 0.4. See Port I/O Section for a complete description.
TX		D Out	UART TX Pin. See Port I/O Section.
P0.5	A37	D I/O or A In	Port 0.5. See Port I/O Section for a complete description.
RX		D In	UART RX Pin. See Port I/O Section.
P0.6	A36	D I/O or A In	Port 0.6. See Port I/O Section for a complete description.
CNVSTR		D In	External Convert Start Input for ADC0. See ADC0 section for a complete description.

Table 3.1. Pin Definitions for the Si102x/3x (Continued)

Name	Pin Number	Type	Description
P0.7	A35	D I/O or A In	Port 0.7. See Port I/O Section for a complete description.
IREF0		A Out	IREF0 Output. See IREF Section for complete description.
P1.0	A34	D I/O or A In	Port 1.0. See Port I/O Section for a complete description. May also be used as SCK for SPI0.
PC0		D I/O	Pulse Counter 0.
P1.1	A33	D I/O or A In	Port 1.1. See Port I/O Section for a complete description. May also be used as MISO for SPI0.
PC1		D I/O	Pulse Counter 1.
P1.2	A31	D I/O or A In	Port 1.2. See Port I/O Section for a complete description. May also be used as MOSI for SPI0.
XTAL3		A In	SmaRTClock Oscillator Crystal Input.
P1.3	A30	D I/O or A In	Port 1.3. See Port I/O Section for a complete description. May also be used as NSS for SPI0.
XTAL4		A Out	SmaRTClock Oscillator Crystal Output.
P1.4	A28	D I/O or A In	Port 1.4. See Port I/O Section for a complete description.
P1.5	A27	D I/O or A In	Port 1.5. See Port I/O Section for a complete description.
P1.6	A26	D I/O or A In	Port 1.6. See Port I/O Section for a complete description.
P1.7	D7	D I/O or A In	Port 1.7. See Port I/O Section for a complete description.
P2.4	A12	D I/O or A In	Port 2.4. See Port I/O Section for a complete description.
COM0		A O	LCD Common Pin 0 (Backplane Driver)
P2.5	B10	D I/O or A In	Port 2.5. See Port I/O Section for a complete description.
COM1		A O	LCD Common Pin 1 (Backplane Driver)
P2.6	A11	D I/O or A In	Port 2.6. See Port I/O Section for a complete description.
COM2		A O	LCD Common Pin 2 (Backplane Driver)

Si102x/3x

Table 3.1. Pin Definitions for the Si102x/3x (Continued)

Name	Pin Number	Type	Description
P2.7	A10	D I/O or A In	Port 2.7. See Port I/O Section for a complete description.
COM2		A O	LCD Common Pin 3 (Backplane Driver)
P3.0	A9	D I/O or A In	Port 3.0. See Port I/O Section for a complete description.
LCD0		A O	LCD Segment Pin 0
P3.1	A8	D I/O or A In	Port 3.1. See Port I/O Section for a complete description.
LCD1		A O	LCD Segment Pin 1
P3.2	A7	D I/O or A In	Port 3.2. See Port I/O Section for a complete description.
LCD2		A O	LCD Segment Pin 2
P3.3	A6	D I/O or A In	Port 3.3. See Port I/O Section for a complete description.
LCD3		A O	LCD Segment Pin 3
P3.4	A5	D I/O or A In	Port 3.4. See Port I/O Section for a complete description.
LCD4		A O	LCD Segment Pin 4
P3.5	A4	D I/O or A In	Port 3.5. See Port I/O Section for a complete description.
LCD5		A O	LCD Segment Pin 5
P3.6	A3	D I/O or A In	Port 3.6. See Port I/O Section for a complete description.
LCD6		A O	LCD Segment Pin 6
P3.7	A2	D I/O or A In	Port 3.7. See Port I/O Section for a complete description.
LCD7		A O	LCD Segment Pin 7
P4.0	A1	D I/O or A In	Port 4.0. See Port I/O Section for a complete description.
LCD8		A O	LCD Segment Pin 8

Table 3.1. Pin Definitions for the Si102x/3x (Continued)

Name	Pin Number	Type	Description
P4.1	B25	D I/O or A In	Port 4.1. See Port I/O Section for a complete description.
LCD9		A O	LCD Segment Pin 9
P4.2	B24	D I/O or A In	Port 4.2. See Port I/O Section for a complete description.
LCD10		A O	LCD Segment Pin 10
P4.3	B23	D I/O or A In	Port 4.3. See Port I/O Section for a complete description.
LCD11		A O	LCD Segment Pin 11
P4.4	D4/D8	D I/O or A In	Port 4.4. See Port I/O Section for a complete description.
LCD12		A O	LCD Segment Pin 12
P4.5	B22	D I/O or A In	Port 4.5. See Port I/O Section for a complete description.
LCD13		A O	LCD Segment Pin 13
P4.6	B21	D I/O or A In	Port 4.6. See Port I/O Section for a complete description.
LCD14		A O	LCD Segment Pin 14
P4.7	B20	D I/O or A In	Port 4.7. See Port I/O Section for a complete description.
LCD15		A O	LCD Segment Pin 15
P5.0	B19	D I/O or A In	Port 5.0. See Port I/O Section for a complete description.
LCD16		A O	LCD Segment Pin 16
P5.1	B18	D I/O or A In	Port 5.1. See Port I/O Section for a complete description.
LCD17		A O	LCD Segment Pin 17
P5.2	B15	D I/O or A In	Port 5.2. See Port I/O Section for a complete description.
LCD18		A O	LCD Segment Pin 18

Si102x/3x

Table 3.1. Pin Definitions for the Si102x/3x (Continued)

Name	Pin Number	Type	Description
P5.3	B14	D I/O or A In	Port 5.3. See Port I/O Section for a complete description.
LCD19		A O	LCD Segment Pin 19
P5.4	B13	D I/O or A In	Port 5.4. See Port I/O Section for a complete description.
LCD20		A O	LCD Segment Pin 20
P5.5	B12	D I/O or A In	Port 5.5. See Port I/O Section for a complete description.
LCD21		A O	LCD Segment Pin 21
P5.6	B9	D I/O or A In	Port 5.6. See Port I/O Section for a complete description.
LCD22		A O	LCD Segment Pin 22
P5.7	B8	D I/O or A In	Port 5.7. See Port I/O Section for a complete description.
LCD23		A O	LCD Segment Pin 23
P6.0	B7	D I/O or A In	Port 6.0. See Port I/O Section for a complete description.
LCD24		A O	LCD Segment Pin 24
P6.1	B6	D I/O or A In	Port 6.1. See Port I/O Section for a complete description.
LCD25		A O	LCD Segment Pin 25
P6.2	B5	D I/O or A In	Port 6.2. See Port I/O Section for a complete description.
LCD26		A O	LCD Segment Pin 26
P6.3	B4	D I/O or A In	Port 6.3. See Port I/O Section for a complete description.
LCD27		A O	LCD Segment Pin 27
P6.4	B3	D I/O or A In	Port 6.4. See Port I/O Section for a complete description.
LCD28		A O	LCD Segment Pin 28

Table 3.1. Pin Definitions for the Si102x/3x (Continued)

Name	Pin Number	Type	Description
P6.5	B2	D I/O or A In	Port 6.5. See Port I/O Section for a complete description.
LCD29		A O	LCD Segment Pin 29
P6.6	B1	D I/O or A In	Port 6.6. See Port I/O Section for a complete description.
LCD30		A O	LCD Segment Pin 30
P6.7	D1/D5	D I/O or A In	Port 6.7. See Port I/O Section for a complete description.
LCD31		A O	LCD Segment Pin 31
VDD_RF	A17	P In	+1.8 to +3.6 V supply voltage input to all analog +1.7 V regulators. The recommended VDD supply voltage is +3.3 V
TX	A18	A O	Transmit output pin. The PA output is an open-drain connection so the L-C match must supply VDD (+3.3 VDC nominal) to this pin.
RXp	A19	A I	Differential RF input pins of the LNA. See application schematic for example matching network.
RXn	A20	A I	
NC	A16	—	No Connect. Not connected internally to any circuitry.
ANT_A	A21	D O	Extra antenna or TR switch control to be used if more GPIO are required. Pin is a hardwired version of GPIO setting 11000, Antenna 2 and can be manually controlled by the antdiv[2:0] bits in register 08h. See register description of 08h.
GPIO_0	A22	D I/O	General Purpose Digital I/O that may be configured through the registers to perform various functions including: Microcontroller Clock Output, FIFO status, POR, Wake-Up timer, Low Battery Detect, T/R switch, AntDiversity control, etc. See the SPI GPIO Configuration Registers, Address 0Bh, 0Ch, and 0Dh for more information.
GPIO_1	A23	D I/O	
GPIO_2	A24	D I/O	
VR_DIG	D3	P Out	Regulated Output Voltage of the Digital 1.7 V regulator. A 1 μ F decoupling capacitor is required.
VDD_DIG	A25	P In	+1.8 to +3.6 V supply voltage input to the Digital +1.7 V regulator. The recommended VDD supply voltage is +3.3 V.
nIRQ	B11	D O	General Microcontroller Interrupt Status output. When the EZRadioPRO transceiver exhibits anyone of the Interrupt Events, the nIRQ pin will be set low. Please see the Control Logic registers section for more information on the Interrupt Events. The Microcontroller can then determine the state of the interrupt by reading a corresponding SPI Interrupt Status Registers, Address 03h and 04h. No external resistor pull-up is required, but it may be desirable if multiple interrupt lines are connected.

Si102x/3x

Table 3.1. Pin Definitions for the Si102x/3x (Continued)

Name	Pin Number	Type	Description
XOUT	A13	D I or A I/O	Crystal Oscillator Output/External Reference Input. Connect to an external 30 MHz crystal or to an external source. If using an external source with no crystal, then DC coupling with a nominal 0.8 VDC level is recommended with a minimum amplitude of 700 mVpp.
XIN	A14	D O or A I/O	Crystal Oscillator Input. Connect to an external 30 MHz crystal or leave floating when driving with an external source on XOUT.
SDN	A15	D I	Shutdown input pin. SDN should be low in all modes except Shutdown mode. When SDN is high, the radio will be completely shut down, and the contents of the registers will be lost.

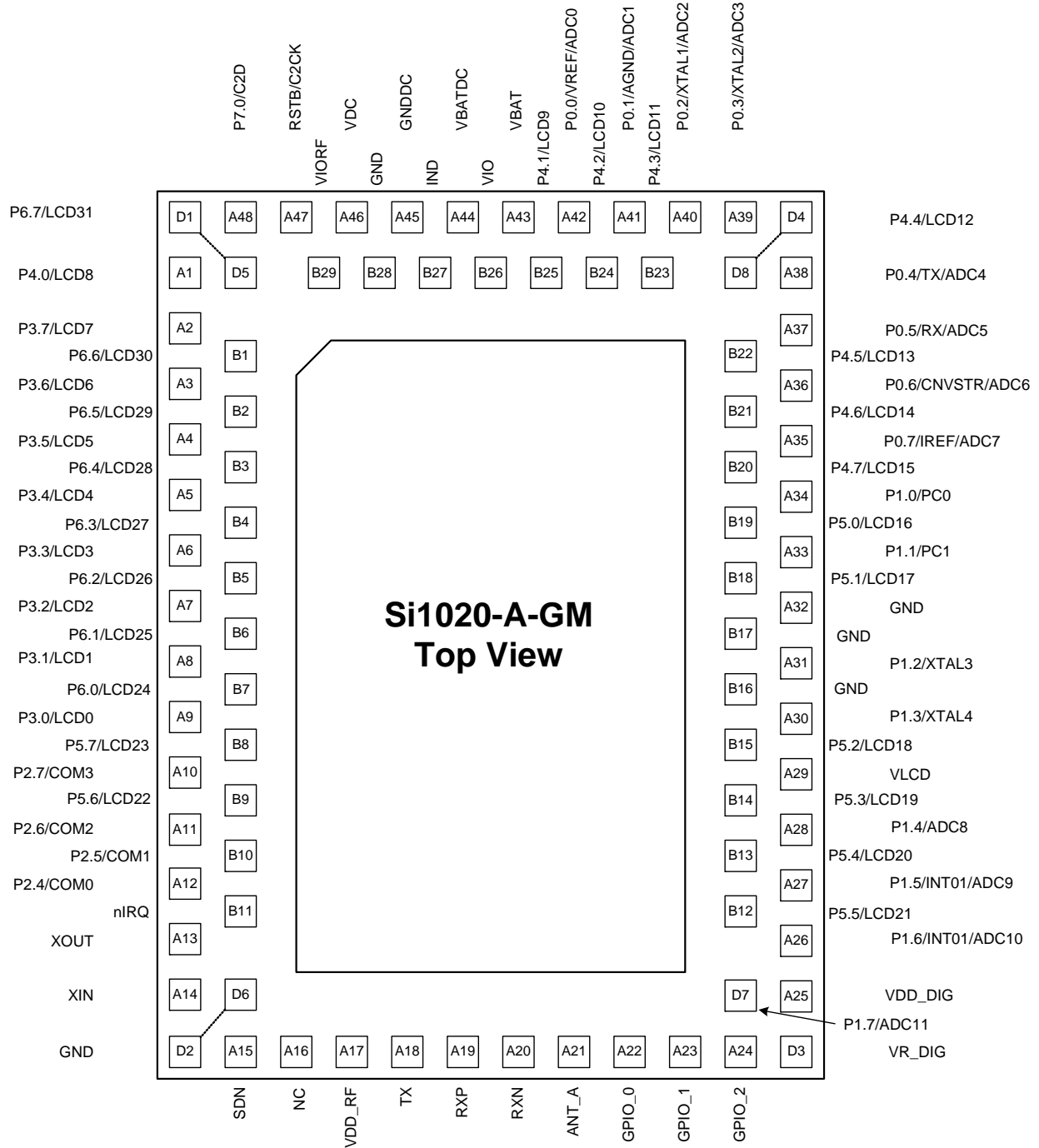

Figure 3.1. LGA-85 Pinout Diagram (Top View)

Si102x/3x

3.1. LGA-85 Package Specifications

3.1.1. Package Drawing

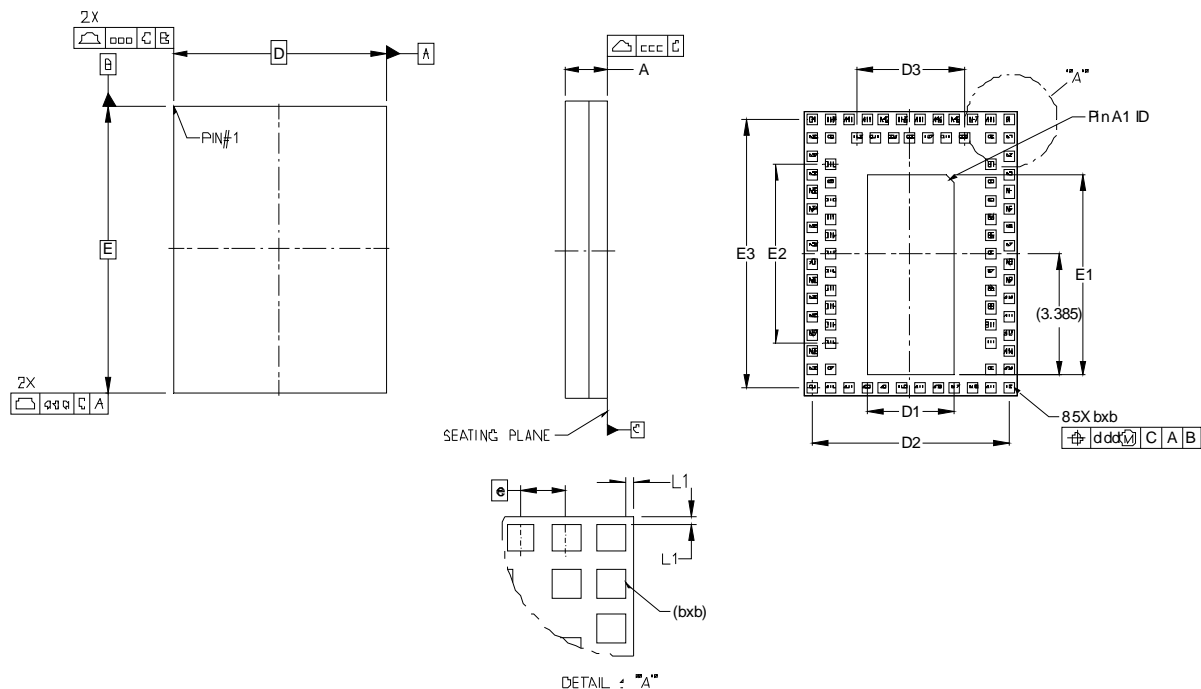

Figure 3.2. LGA-85 Package Drawing

Table 3.2. LGA-85 Package Dimensions

Dimension	Min	Nom	Max
A	0.74	0.84	0.94
b	0.25	0.30	0.35
D	6.00 BSC.		
D1	—	2.40	—
D2	—	5.50	—
D3	—	3.00	—
e	0.50 BSC.		
E	8.00 BSC.		
Notes:			
1. All dimensions shown are in millimeters (mm) unless otherwise noted.			
2. Dimensioning and Tolerancing per ANSI Y14.5M-1994.			
3. Recommended card reflow profile is per the JEDEC/IPC J-STD-020 specification for Small Body Components.			

Table 3.2. LGA-85 Package Dimensions (Continued)

Dimension	Min	Nom	Max
E1	—	5.60	—
E2	—	5.00	—
E3	—	7.50	—
L1	—	0.10	—
aaa	—	—	0.10
bbb	—	—	0.10
ccc	—	—	0.08
ddd	—	—	0.10

Notes:

1. All dimensions shown are in millimeters (mm) unless otherwise noted.
2. Dimensioning and Tolerancing per ANSI Y14.5M-1994.
3. Recommended card reflow profile is per the JEDEC/IPC J-STD-020 specification for Small Body Components.

3.1.2. Land Pattern

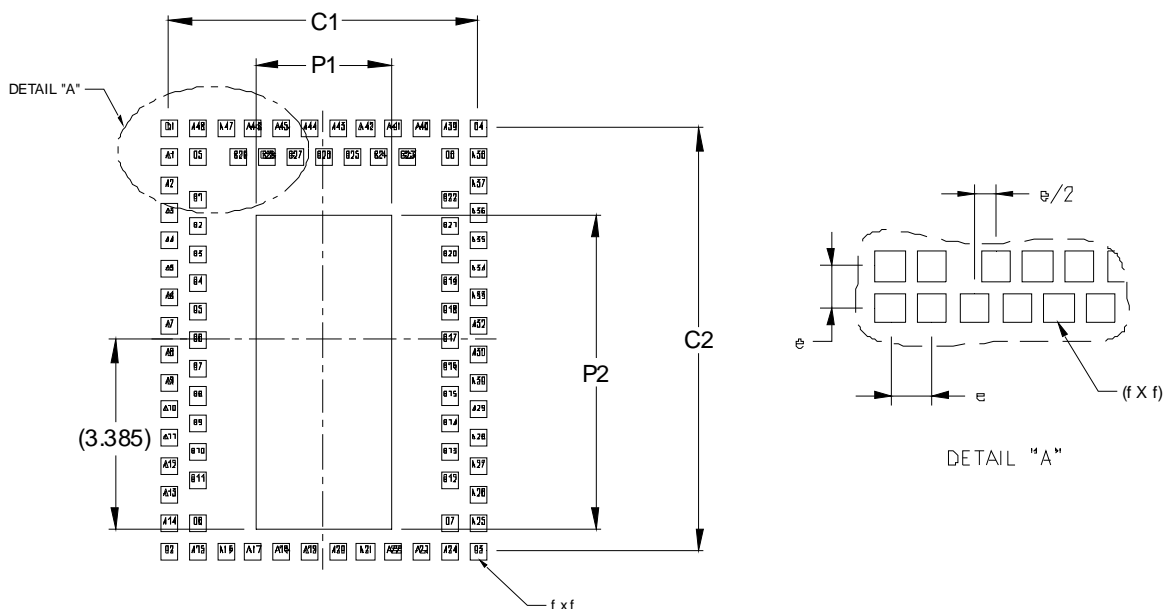

Figure 3.3. LGA-85 Land Pattern

Table 3.3. LGA-85 Land Pattern Dimensions

Symbol	Max (mm)
C1	5.50
C2	7.50
e	0.50
f	0.35
P1	2.40
P2	5.60

Notes:

General

1. All feature sizes shown are at Maximum Material Condition (MMC) and a card fabrication tolerance of 0.05mm is assumed.
2. Dimensioning and Tolerancing is per the ANSI Y14.5M-1994 specification.
3. This Land Pattern Design is based on the IPC-7351 guidelines.

Solder Mask Design

4. All metal pads are to be non-solder mask defined (NSMD). Clearance between the solder mask and the metal pad is to be 60 μm minimum, all the way around the pad.

Stencil Design

5. A stainless steel, laser-cut and electro-polished stencil with trapezoidal walls should be used to assure good solder paste release.
6. The stencil thickness should be 0.125mm (5 mils).
7. The ratio of stencil aperture to land pad size should be 1:1 for all perimeter pins.
8. A 2x3 array of 0.72x1.45mm openings on 1.77 mm pitch should be used for the center ground pad.

Card Assembly

9. A No-Clean, Type-3 solder paste is recommended.
10. The recommended card reflow profile is per the JEDEC/IPC J-STD-020 specification for Small Body Components.

3.1.3. Soldering Guidelines

3.1.3.1. Solder Mask Design

All metal pads are to be non-solder mask defined (NSMD). Clearance between the solder mask and the metal pad is to be 60 μm minimum, all the way around the pad.

3.1.3.2. Stencil Design

1. A stainless steel, laser-cut and electro-polished stencil with trapezoidal walls should be used to assure good solder paste release.
2. The stencil thickness should be 0.125 mm (5 mils).
3. The ratio of stencil aperture to land pad size should be 1:1 for all perimeter pads.
4. A 2x3 array of 0.72x1.45 mm openings on 1.77 mm pitch should be used for the center ground pad. Opening size may be reduced as needed to adjust ratio of solder on center ground pad to solder of signal pins. Excessive solder on center pad may cause opens on signal pins.

3.1.3.3. Card Assembly

1. A No-Clean, Type-3 solder paste is recommended.
2. The recommended card reflow profile is per the JEDEC/IPC J-STD-020 specification for Small Body Components (>245 $^{\circ}\text{C}$ for >20 seconds at peak).

Si102x/3x

4. Electrical Characteristics

Throughout the MCU Electrical Characteristics chapter:

- “VDD” refers to the VBAT or VBATDC Supply Voltage.
- “VIO” refers to the VIO or VIOVF Supply Voltage.

4.1. Absolute Maximum Specifications

Table 4.1. Absolute Maximum Ratings

Parameter	Conditions	Min	Typ	Max	Units
Ambient Temperature under Bias		-55	—	125	°C
Storage Temperature		-65	—	150	°C
Voltage on any Port I/O Pin or $\overline{\text{RST}}$ with Respect to GND		-0.3	—	VIO + 2	V
Voltage on VDD with Respect to GND		-0.3	—	4.0	V
Maximum Total Current through VDD or GND		—	—	500	mA
Maximum Current through $\overline{\text{RST}}$ or any Port Pin		—	—	100	mA
Maximum Total Current through all Port Pins		—	—	200	mA

Note: Stresses above those listed under “Absolute Maximum Ratings” may cause permanent damage to the device. This is a stress rating only and functional operation of the devices at those or any other conditions above those indicated in the operation listings of this specification is not implied. Exposure to maximum rating conditions for extended periods may affect device reliability.

4.2. MCU Electrical Characteristics

Table 4.2. Global Electrical Characteristics

–40 to +85 °C, 25 MHz system clock unless otherwise specified.

Parameter	Conditions	Min	Typ	Max	Units
Supply Voltage (V_{DD})		1.8		3.8	V
Minimum RAM Data Retention Voltage ¹	not in sleep mode in sleep mode	— —	1.4 0.3	— 0.5	V
SYSCLK (System Clock) ²		0	—	25	MHz
T_{SYSH} (SYSCLK High Time)		18	—	—	ns
T_{SYSL} (SYSCLK Low Time)		18	—	—	ns
Specified Operating Temperature Range		–40	—	+85	°C

Table 4.3. Digital Supply Current at VBAT pin with DC-DC Converter Enabled

–40 to +85 °C, VBAT = 3.6V, VDC = 1.9V, 24.5 MHz system clock unless otherwise specified.

Parameter	Conditions	Min	Typ	Max	Units
Digital Supply Current—CPU Active (Normal Mode, fetching instructions from flash, no external load)					
$I_{BAT}^{1,2,3}$	$V_{BAT} = 3.0\text{ V}$	—	4.5	—	mA
	$V_{BAT} = 3.3\text{ V}$	—	4.3	—	mA
	$V_{BAT} = 3.6\text{ V}$	—	4.2	—	mA
Digital Supply Current—CPU Inactive (Sleep Mode, sourcing current to external device)					
I_{BAT}^1	sourcing 9 mA to external device	—	6.5	—	mA
	sourcing 19 mA to external device	—	13	—	mA
Notes:					
1. Based on device characterization data; Not production tested.					
2. Digital Supply Current depends upon the particular code being executed. The values in this table are obtained with the CPU executing a mix of instructions in two loops: djnz R1, \$, followed by a loop that accesses an SFR, and moves data around using the CPU (between accumulator and b-register). The supply current will vary slightly based on the physical location of this code in flash. As described in the Flash Memory chapter, it is best to align the jump addresses with a flash word address (byte location /4), to minimize flash accesses and power consumption.					
3. Includes oscillator and regulator supply current.					

Si102x/3x

Table 4.4. Digital Supply Current with DC-DC Converter Disabled

–40 to +85 °C, 25 MHz system clock unless otherwise specified.

Parameter	Conditions	Min	Typ	Max	Units
Digital Supply Current - Active Mode, No Clock Gating (PCLKACT=0x0F) (CPU Active, fetching instructions from flash)					
$I_{DD}^{3,4}$	$V_{DD} = 1.8\text{--}3.8\text{ V}$, $F = 24.5\text{ MHz}$ (includes precision oscillator current)	—	4.9	6.2	mA
	$V_{DD} = 1.8\text{--}3.8\text{ V}$, $F = 20\text{ MHz}$ (includes low power oscillator current)	—	3.9	—	mA
	$V_{DD} = 1.8\text{ V}$, $F = 1\text{ MHz}$ $V_{DD} = 3.8\text{ V}$, $F = 1\text{ MHz}$ (includes external oscillator/GPIO current)	— —	175 190	— —	μA μA
	$V_{DD} = 1.8\text{--}3.8\text{ V}$, $F = 32.768\text{ kHz}$ (includes SmarTClock oscillator current)	—	85	—	μA
I_{DD} Frequency Sensitivity ^{1,3}	$V_{DD} = 1.8\text{--}3.8\text{ V}$, $T = 25\text{ }^\circ\text{C}$	—	183	—	$\mu\text{A}/\text{MHz}$
Digital Supply Current - Active Mode, All Peripheral Clocks Disabled (PCLKACT=0x00) (CPU Active, fetching instructions from flash)					
$I_{DD}^{3,4}$	$V_{DD} = 1.8\text{--}3.8\text{ V}$, $F = 24.5\text{ MHz}$ (includes precision oscillator current)	—	3.9	--	mA
	$V_{DD} = 1.8\text{--}3.8\text{ V}$, $F = 20\text{ MHz}$ (includes low power oscillator current)	—	3.1	—	mA
	$V_{DD} = 1.8\text{ V}$, $F = 1\text{ MHz}$ $V_{DD} = 3.8\text{ V}$, $F = 1\text{ MHz}$ (includes external oscillator/GPIO current)	— —	165 180	— —	μA μA
I_{DD} Frequency Sensitivity ^{1,3}	$V_{DD} = 1.8\text{--}3.8\text{ V}$, $T = 25\text{ }^\circ\text{C}$	—	TBD	—	$\mu\text{A}/\text{MHz}$
Digital Supply Current—Idle Mode (CPU Inactive, not fetching instructions from flash)					
I_{DD}^4	$V_{DD} = 1.8\text{--}3.8\text{ V}$, $F = 24.5\text{ MHz}$ (includes precision oscillator current)	—	3.5	—	mA
	$V_{DD} = 1.8\text{--}3.8\text{ V}$, $F = 20\text{ MHz}$ (includes low power oscillator current)	—	2.6	—	mA
	$V_{DD} = 1.8\text{ V}$, $F = 1\text{ MHz}$ $V_{DD} = 3.8\text{ V}$, $F = 1\text{ MHz}$ (includes external oscillator/GPIO current)	— —	340 360	— —	μA μA
	$V_{DD} = 1.8\text{--}3.8\text{ V}$, $F = 32.768\text{ kHz}$ (includes SmarTClock oscillator current)	—	230 ⁵	—	μA
I_{DD} Frequency Sensitivity ¹	$V_{DD} = 1.8\text{--}3.8\text{ V}$, $T = 25\text{ }^\circ\text{C}$	—	135	—	$\mu\text{A}/\text{MHz}$

Table 4.4. Digital Supply Current with DC-DC Converter Disabled (Continued)

-40 to +85 °C, 25 MHz system clock unless otherwise specified.

Parameter	Conditions	Min	Typ	Max	Units
Digital Supply Current— Low Power Idle Mode, All peripheral clocks enabled (PCLKEN = 0x0F) (CPU Inactive, not fetching instructions from flash)					
$I_{DD}^{4,6}$	$V_{DD} = 1.8\text{--}3.8\text{ V}$, $F = 24.5\text{ MHz}$ (includes precision oscillator current)	—	1.5	1.9	mA
	$V_{DD} = 1.8\text{--}3.8\text{ V}$, $F = 20\text{ MHz}$ (includes low power oscillator current)	—	1.07	—	mA
	$V_{DD} = 1.8\text{ V}$, $F = 1\text{ MHz}$ $V_{DD} = 3.8\text{ V}$, $F = 1\text{ MHz}$ (includes external oscillator/GPIO current)	— —	270 280	— —	μA μA
	$V_{DD} = 1.8\text{--}3.8\text{ V}$, $F = 32.768\text{ kHz}$ (includes SmarTClock oscillator current)	—	232 ⁵	—	μA
I_{DD} Frequency Sensitivity ¹	$V_{DD} = 1.8\text{--}3.8\text{ V}$, $T = 25\text{ }^\circ\text{C}$	—	47 ⁵	—	$\mu\text{A}/\text{MHz}$
Digital Supply Current— Low Power Idle Mode, All Peripheral Clocks Disabled (PCLKEN = 0x00) (CPU Inactive, not fetching instructions from flash)					
$I_{DD}^{4,7}$	$V_{DD} = 1.8\text{--}3.8\text{ V}$, $F = 24.5\text{ MHz}$ (includes precision oscillator current)	—	620	TBD	μA
	$V_{DD} = 1.8\text{--}3.8\text{ V}$, $F = 20\text{ MHz}$ (includes low power oscillator current)	—	340	—	μA
	$V_{DD} = 1.8\text{ V}$, $F = 1\text{ MHz}$ $V_{DD} = 3.8\text{ V}$, $F = 1\text{ MHz}$ (includes external oscillator/GPIO current)	— —	TBD TBD	— —	μA μA
I_{DD} Frequency Sensitivity ¹	$V_{DD} = 1.8\text{--}3.8\text{ V}$, $T = 25\text{ }^\circ\text{C}$	—	11 ⁵	—	$\mu\text{A}/\text{MHz}$
Digital Supply Current—Suspend Mode					
Digital Supply Current (Suspend Mode)	$V_{DD} = 1.8\text{ V}$	—	77	—	μA
	$V_{DD} = 3.8\text{ V}$	—	84	—	

Si102x/3x

Table 4.4. Digital Supply Current with DC-DC Converter Disabled (Continued)

–40 to +85 °C, 25 MHz system clock unless otherwise specified.

Parameter	Conditions	Min	Typ	Max	Units
Digital Supply Current—Sleep Mode (LCD Enabled, RTC enabled)					
Digital Supply Current (Sleep Mode, SmaRTClock running, internal LFO, LCD Contrast Mode 1, charge pump disabled, 60 Hz refresh rate, driving 32 segment pins w/ no load)	1.8 V, T = 25 °C, static LCD	—	0.4	—	μA
	3.0 V, T = 25 °C, static LCD	—	0.6	—	
	3.8 V, T = 25 °C, static LCD	—	0.8	—	
Digital Supply Current (Sleep Mode, SmaRTClock running, internal LFO, LCD Contrast Mode 1, charge pump disabled, 60 Hz refresh rate, driving 32 segment pins w/ no load)	1.8 V, T = 25 °C, 2-Mux LCD	—	0.9	—	μA
	3.0 V, T = 25 °C, 2-Mux LCD	—	1.1	—	
	3.8 V, T = 25 °C, 2-Mux LCD	—	1.3	—	
Digital Supply Current (Sleep Mode, SmaRTClock running, internal LFO, LCD Contrast Mode 1, charge pump disabled, 60 Hz refresh rate, driving 32 segment pins w/ no load)	1.8 V, T = 25 °C, 4-Mux LCD	—	1.2	—	μA
	3.0 V, T = 25 °C, 4-Mux LCD	—	1.4	—	
	3.8 V, T = 25 °C, 4-Mux LCD	—	1.6	—	
Digital Supply Current (Sleep Mode, SmaRTClock running, 32.768 kHz Crystal, LCD Contrast Mode 1, charge pump disabled, 60 Hz refresh rate, driving 32 segment pins w/ no load)	1.8 V, T = 25 °C, static LCD	—	0.8	—	μA
	3.0 V, T = 25 °C, static LCD	—	1.1	—	
	3.8 V, T = 25 °C, static LCD	—	1.4	—	
Digital Supply Current (Sleep Mode, SmaRTClock running, 32.768 kHz Crystal, LCD Contrast Mode 1, charge pump disabled, 60 Hz refresh rate, driving 32 segment pins w/ no load)	1.8 V, T = 25 °C, 2-Mux LCD	—	1.2	—	μA
	3.0 V, T = 25 °C, 2-Mux LCD	—	1.7	—	
	3.8 V, T = 25 °C, 2-Mux LCD	—	2.0	—	
Digital Supply Current (Sleep Mode, SmaRTClock running, 32.768 kHz Crystal, LCD Contrast Mode 1, charge pump disabled, 60 Hz refresh rate, driving 32 segment pins w/ no load)	1.8 V, T = 25 °C, 4-Mux LCD	—	1.4	—	μA
	3.0 V, T = 25 °C, 4-Mux LCD	—	1.8	—	
	3.8 V, T = 25 °C, 4-Mux LCD	—	2.1	—	
Digital Supply Current (Sleep Mode, SmaRTClock running, internal LFO, LCD Contrast Mode 3 (2.7 V), charge pump enabled, 60 Hz refresh rate, driving 32 segment pins w/ no load)	1.8 V, T = 25 °C, static LCD	—	1.2	—	μA
	1.8 V, T = 25 °C, 2-Mux LCD	—	1.6	—	
	1.8 V, T = 25 °C, 3-Mux LCD	—	1.8	—	
	1.8 V, T = 25 °C, 4-Mux LCD	—	2.0	—	
Digital Supply Current (Sleep Mode, SmaRTClock running, 32.768 kHz Crystal, LCD Contrast Mode 3 (2.7 V), charge pump enabled, 60 Hz refresh rate, driving 32 segment pins w/ no load)	1.8 V, T = 25 °C, static LCD	—	1.3	—	μA
	1.8 V, T = 25 °C, 2-Mux LCD	—	1.8	—	
	1.8 V, T = 25 °C, 3-Mux LCD	—	1.8	—	
	1.8 V, T = 25 °C, 4-Mux LCD	—	2.0	—	

Table 4.4. Digital Supply Current with DC-DC Converter Disabled (Continued)

–40 to +85 °C, 25 MHz system clock unless otherwise specified.

Parameter	Conditions	Min	Typ	Max	Units
Digital Supply Current—Sleep Mode (LCD disabled, RTC enabled)					
Digital Supply Current (Sleep Mode, SmaRTClock running, 32.768 kHz crystal)	1.8 V, T = 25 °C	—	0.40	—	μA
	3.0 V, T = 25 °C	—	0.60	—	
	3.8 V, T = 25 °C	—	0.70	—	
	1.8 V, T = 85 °C	—	1.56	—	
	3.0 V, T = 85 °C	—	2.38	—	
	3.8 V, T = 85 °C	—	2.79	—	
	(includes SmaRTClock oscillator and V _{BAT} Supply Monitor)	—		—	
Digital Supply Current (Sleep Mode, SmaRTClock running, internal LFO)	1.8 V, T = 25 °C	—	0.20	—	μA
	3.0 V, T = 25 °C	—	0.30	—	
	3.8 V, T = 25 °C	—	0.40	—	
	1.8 V, T = 85 °C	—	1.30	—	
	3.0 V, T = 85 °C	—	2.06	—	
	3.8 V, T = 85 °C	—	2.41	—	
	(includes SmaRTClock oscillator and V _{BAT} Supply Monitor)	—		—	
Digital Supply Current—Sleep Mode (LCD disabled, RTC disabled)					
Digital Supply Current (Sleep Mode)	1.8 V, T = 25 °C	—	0.05	—	μA
	3.0 V, T = 25 °C	—	0.07	—	
	3.8 V, T = 25 °C	—	0.11	—	
	1.8 V, T = 85 °C	—	1.13	—	
	3.0 V, T = 85 °C	—	1.83	—	
	3.8 V, T = 85 °C	—	2.25	—	
	(includes POR supply monitor)	—		—	
Digital Supply Current (Sleep Mode, VBAT Supply Monitor Disabled)	1.8 V, T = 25 °C	—	0.01	—	μA
	3.0 V, T = 25 °C	—	0.02	—	
	3.8 V, T = 25 °C	—	0.03	—	
	1.8 V, T = 85 °C	—	TBD	—	
	3.0 V, T = 85 °C	—	TBD	—	
	3.8 V, T = 85 °C	—	TBD	—	

Notes:

1. Based on device characterization data; Not production tested.
2. SYSCLK must be at least 32 kHz to enable debugging.
3. Active Current measure using typical code loop - Digital Supply Current depends upon the particular code being executed. Digital Supply Current depends on the particular code being executed. The values in this table are obtained with the CPU executing a mix of instructions in two loops: djnz R1, \$, followed by a loop that accesses an SFR, and moves data around using the CPU (between accumulator and b-register). The supply current will vary slightly based on the physical location of this code in flash. As described in the Flash Memory chapter, it is best to align the jump addresses with a flash word address (byte location /4), to minimize flash accesses and power consumption.
4. Includes oscillator and regulator supply current.
5. Using SmaRTClock oscillator with external 32.768 kHz CMOS clock. Does not include crystal bias current.
6. Low-Power Idle mode current measured with CLKMODE = 0x04, PCON = 0x01, and PCLKEN = 0x0F.
7. Low-Power Idle mode current measured with CLKMODE = 0x04, PCON = 0x01, and PCLKEN = 0x00.

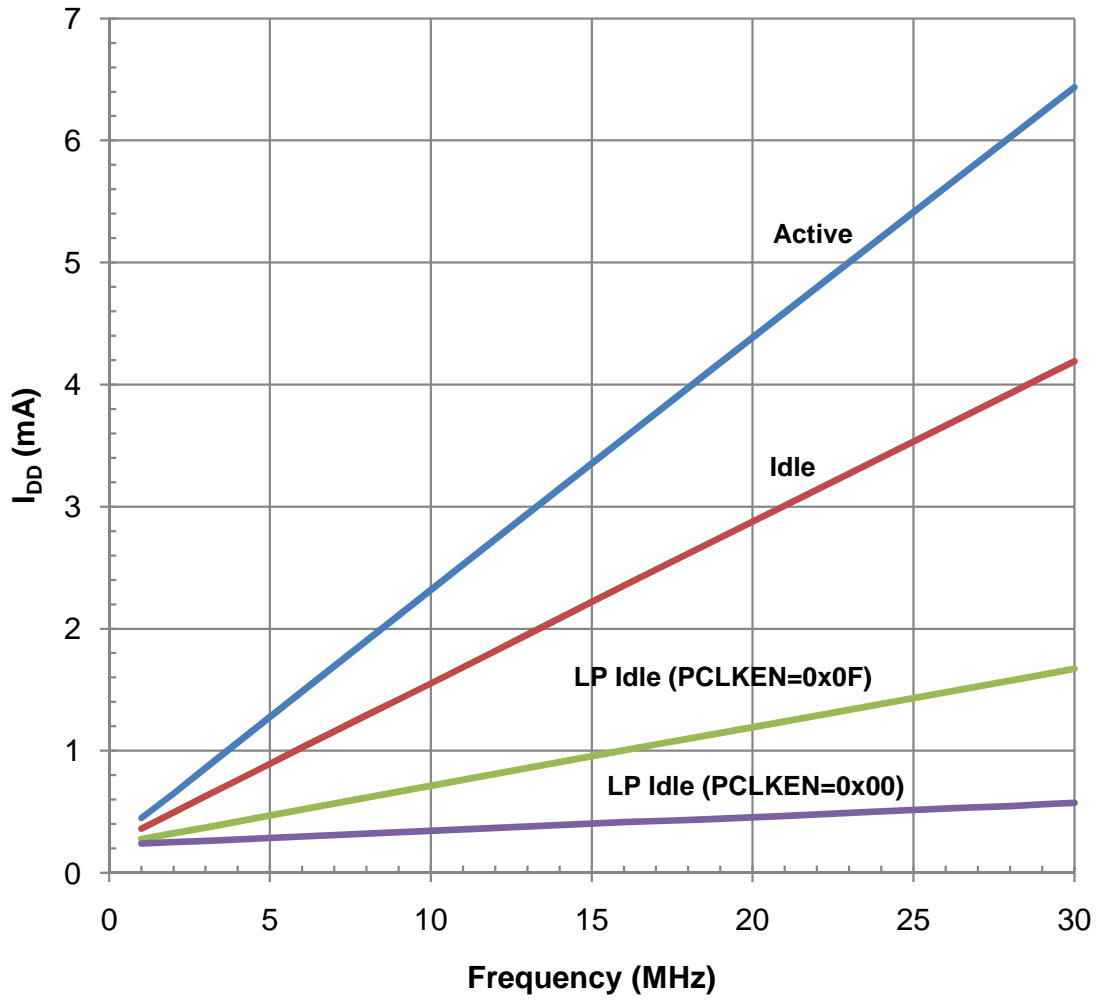

Figure 4.1. Frequency Sensitivity (External CMOS Clock, 25°C)

Table 4.5. Port I/O DC Electrical Characteristics $V_{IO} = 1.8$ to 3.8 V, -40 to $+85$ °C unless otherwise specified.

Parameters	Conditions	Min	Typ	Max	Units
Output High Voltage	High Drive Strength, PnDRV.n = 1				V
	IOH = -3 mA, Port I/O push-pull	$V_{IO} - 0.7$	—	—	
	IOH = -10 μ A, Port I/O push-pull	$V_{IO} - 0.1$	—	—	
	IOH = -10 mA, Port I/O push-pull		See Chart		
	Low Drive Strength, PnDRV.n = 0				
	IOH = -1 mA, Port I/O push-pull	$V_{IO} - 0.7$	—	—	
Output Low Voltage	High Drive Strength, PnDRV.n = 1				V
	I _{OL} = 8.5 mA	—	—	0.6	
	I _{OL} = 10 μ A	—	—	0.1	
	I _{OL} = 25 mA	—	See Chart	—	
	Low Drive Strength, PnDRV.n = 0				
	I _{OL} = 1.4 mA	—	—	0.6	
Input High Voltage	$V_{DD} = 2.0$ to 3.8 V	$V_{IO} - 0.6$	—	—	V
	$V_{DD} = 1.8$ to 2.0 V	$0.7 \times V_{IO}$	—	—	V
Input Low Voltage	$V_{DD} = 2.0$ to 3.8 V	—	—	0.6	V
	$V_{DD} = 1.8$ to 2.0 V	—	—	$0.3 \times V_{IO}$	V
Input Leakage Current	Weak Pullup Off	—	—	± 1	μ A
	Weak Pullup On, $V_{IN} = 0$ V, $V_{DD} = 1.8$ V	—	4	—	
	Weak Pullup On, $V_{IN} = 0$ V, $V_{DD} = 3.8$ V	—	20	35	

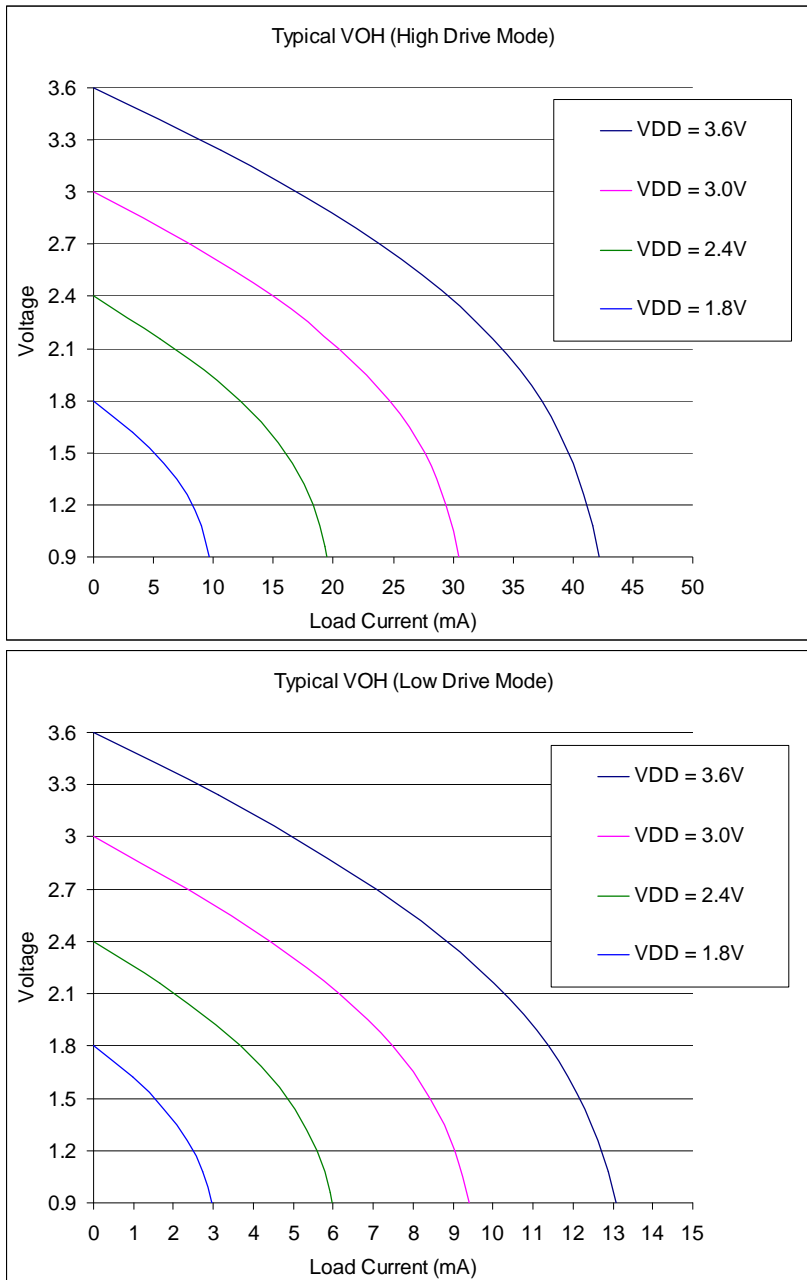

Figure 4.2. Typical VOH Curves, 1.8–3.8 V

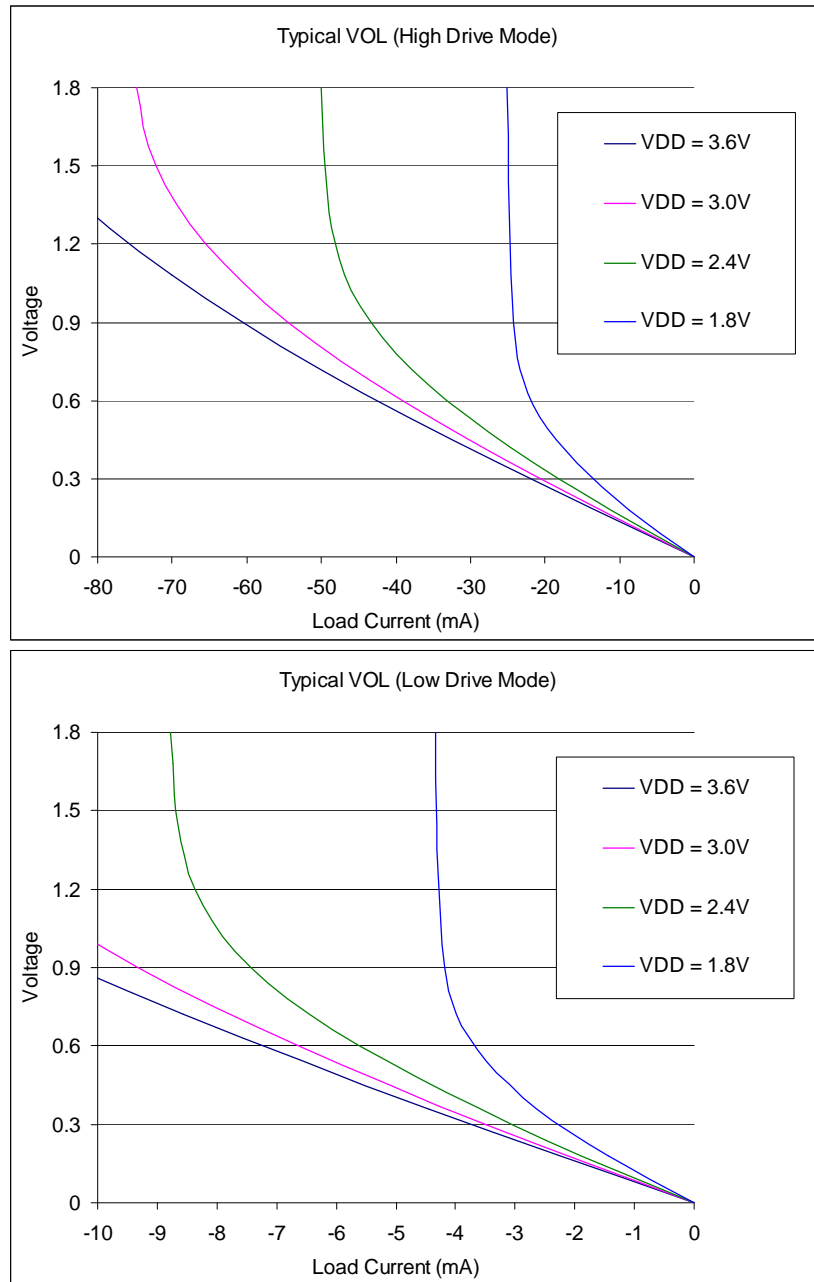

Figure 4.3. Typical VOL Curves, 1.8–3.8 V

Si102x/3x

Table 4.6. Reset Electrical Characteristics

$V_{DD} = 1.8$ to 3.8 V, -40 to $+85$ °C unless otherwise specified.

Parameter	Conditions	Min	Typ	Max	Units
\overline{RST} Output Low Voltage	$I_{OL} = 1.4$ mA,	—	—	0.6	V
\overline{RST} Input High Voltage	$V_{DD} = 2.0$ to 3.8 V	$V_{DD} - 0.6$	—	—	V
	$V_{DD} = 1.8$ to 2.0 V	$0.7 \times V_{DD}$	—	—	V
\overline{RST} Input Low Voltage	$V_{DD} = 2.0$ to 3.8 V	—	—	0.6	V
	$V_{DD} = 1.8$ to 2.0 V	—	—	$0.3 \times V_{DD}$	V
\overline{RST} Input Pullup Current	$\overline{RST} = 0.0$ V, $V_{DD} = 1.8$ V	—	4	—	μ A
	$\overline{RST} = 0.0$ V, $V_{DD} = 3.8$ V	—	20	35	μ A
VDD Monitor Threshold (V_{RST})	Early Warning Reset Trigger (all power modes except Sleep)	1.8	1.85	1.9	V
		1.7	1.75	1.8	V
VBAT Ramp Time for Power On	VBAT Ramp from 0–1.8 V	—	—	3	ms
POR Monitor Threshold (V_{POR})	Brownout Condition (VDD Falling)	0.45	0.7	1.0	V
	Recovery from Brownout (VDD Rising)	—	1.75	—	V
Missing Clock Detector Timeout	Time from last system clock rising edge to reset initiation	100	650	1000	μ s
Minimum System Clock w/ Missing Clock Detector Enabled	System clock frequency which triggers a missing clock detector timeout	—	7	10	kHz
Reset Time Delay	Delay between release of any reset source and code execution at location 0x0000	—	10	—	μ s
Minimum \overline{RST} Low Time to Generate a System Reset		15	—	—	μ s
Digital/Analog Monitor Turn-on Time		—	300	—	ns
Digital Monitor Supply Current		—	14	—	μ A
Analog Monitor Supply Current		—	14	—	μ A

Table 4.7. Power Management Electrical Specifications $V_{DD} = 1.8$ to 3.8 V, -40 to $+85$ °C unless otherwise specified.

Parameter	Conditions	Min	Typ	Max	Units
Idle Mode Wake-up Time		2	—	3	SYCLKs
Suspend Mode Wake-up Time	CLKDIV = 0x00 Low Power or Precision Osc.	—	400	—	ns
Sleep Mode Wake-up Time		—	2	—	μs

Table 4.8. Flash Electrical Characteristics $V_{DD} = 1.8$ to 3.8 V, -40 to $+85$ °C unless otherwise specified.,

Parameter	Conditions	Min	Typ	Max	Units
Flash Size	Si1020/24/30/34	131072	—	—	bytes
	Si1021/25/31/35	65536	—	—	bytes
	Si1022/26/32/36	32768	—	—	bytes
	Si1023/27/33/37	16384	—	—	bytes
Endurance		20 k	100k	—	Erase/Write Cycles
Erase Cycle Time		28	32	36	ms
Write Cycle Time		57	64	71	μs

Table 4.9. Internal Precision Oscillator Electrical Characteristics $V_{DD} = 1.8$ to 3.8 V; $T_A = -40$ to $+85$ °C unless otherwise specified; Using factory-calibrated settings.

Parameter	Conditions	Min	Typ	Max	Units
Oscillator Frequency	-40 to $+85$ °C, $V_{DD} = 1.8$ – 3.8 V	24	24.5	25	MHz
Oscillator Supply Current (from V_{DD})	25 °C; includes bias current of 50 μA typical	—	300*	—	μA

***Note:** Does not include clock divider or clock tree supply current.

Table 4.10. Internal Low-Power Oscillator Electrical Characteristics $V_{DD} = 1.8$ to 3.8 V; $T_A = -40$ to $+85$ °C unless otherwise specified; Using factory-calibrated settings.

Parameter	Conditions	Min	Typ	Max	Units
Oscillator Frequency	-40 to $+85$ °C, $V_{DD} = 1.8$ – 3.8 V	18	20	22	MHz
Oscillator Supply Current (from V_{DD})	25 °C No separate bias current required	—	100*	—	μA

***Note:** Does not include clock divider or clock tree supply current.

Si102x/3x

Table 4.11. SmARTClock Characteristics

$V_{DD} = 1.8$ to 3.8 V; $T_A = -40$ to $+85$ °C unless otherwise specified; Using factory-calibrated settings.

Parameter	Conditions	Min	Typ	Max	Units
Oscillator Frequency (LFO)		13.1	16.4	19.7	kHz

Table 4.12. ADC0 Electrical Characteristics

$V_{DD} = 1.8$ to 3.8 V, $V_{REF} = 1.65$ V ($REFSL[1:0] = 11$), -40 to $+85$ °C unless otherwise specified.

Parameter	Conditions	Min	Typ	Max	Units
DC Accuracy					
Resolution	12-bit mode	12			bits
	10-bit mode	10			
Integral Nonlinearity	12-bit mode ¹	—	±1	±3	LSB
	10-bit mode	—	±0.5	±1	
Differential Nonlinearity (Guaranteed Monotonic)	12-bit mode ¹	—	±0.8	±2	LSB
	10-bit mode	—	±0.5	±1	
Offset Error	12-bit mode	—	±<1	±3	LSB
	10-bit mode	—	±<1	±3	
Full Scale Error	12-bit mode ²	—	±1	±4	LSB
	10-bit mode	—	±1	±2.5	
Dynamic performance (10 kHz sine-wave single-ended input, 1 dB below Full Scale, maximum sampling rate)					
Signal-to-Noise Plus Distortion ³	12-bit mode	62	65	—	dB
	10-bit mode	54	58	—	
Signal-to-Distortion ³	12-bit mode	—	76	—	dB
	10-bit mode	—	73	—	
Spurious-Free Dynamic Range ³	12-bit mode	—	82	—	dB
	10-bit mode	—	75	—	
Conversion Rate					
SAR Conversion Clock	Normal Power Mode	—	—	8.33	MHz
	Low Power Mode	—	—	4.4	
Conversion Time in SAR Clocks	10-bit Mode	13	—	—	clocks
	8-bit Mode	11	—	—	
Track/Hold Acquisition Time	Initial Acquisition	1.5	—	—	us
	Subsequent Acquisitions (DC input, burst mode)	1.1	—	—	
Throughput Rate	12-bit mode	—	—	75	ksps
	10-bit mode	—	—	300	
<ol style="list-style-type: none"> 1. INL and DNL specifications for 12-bit mode do not include the first or last four ADC codes. 2. The maximum code in 12-bit mode is 0xFFFC. The Full Scale Error is referenced from the maximum code. 3. Performance in 8-bit mode is similar to 10-bit mode. 					

Table 4.12. ADC0 Electrical Characteristics (Continued)

$V_{DD} = 1.8$ to 3.8 V, $V_{REF} = 1.65$ V (REFSL[1:0] = 11), -40 to $+85$ °C unless otherwise specified.

Parameter	Conditions	Min	Typ	Max	Units
Analog Inputs					
ADC Input Voltage Range	Single Ended (AIN+ – GND)	0	—	VREF	V
Absolute Pin Voltage with respect to GND	Single Ended	0	—	VDD	V
Sampling Capacitance	1x Gain	—	16	—	pF
	0.5x Gain	—	13	—	pF
Input Multiplexer Impedance		—	5	—	k Ω
Power Specifications					
Power Supply Current (V_{DD} supplied to ADC0)	Normal Power Mode: Conversion Mode (300 ksps)	—	650	—	μ A
	Tracking Mode (0 ksps)	—	740	—	
	Low Power Mode: Conversion Mode (150 ksps)	—	370	—	
	Tracking Mode (0 ksps)	—	400	—	
Power Supply Rejection	Internal High Speed VREF	—	67	—	dB
	External VREF	—	74	—	
<ol style="list-style-type: none"> 1. INL and DNL specifications for 12-bit mode do not include the first or last four ADC codes. 2. The maximum code in 12-bit mode is 0xFFFC. The Full Scale Error is referenced from the maximum code. 3. Performance in 8-bit mode is similar to 10-bit mode. 					

Table 4.13. Temperature Sensor Electrical Characteristics

$V_{DD} = 1.8$ to 3.8 V, -40 to $+85$ °C unless otherwise specified.

Parameter	Conditions	Min	Typ	Max	Units
Linearity		—	± 1	—	°C
Slope		—	3.40	—	mV/°C
Slope Error*		—	40	—	μ V/°C
Offset	Temp = 25 °C	—	1025	—	mV
Offset Error*	Temp = 25 °C	—	18	—	mV
Temperature Sensor Turn-On Time		—	1.7	—	μ s
Supply Current		—	35	—	μ A
*Note: Represents one standard deviation from the mean.					

Si102x/3x

Table 4.14. Voltage Reference Electrical Characteristics

V_{DD} = 1.8 to 3.8 V, -40 to +85 °C unless otherwise specified.

Parameter	Conditions	Min	Typ	Max	Units
Internal High-Speed Reference (REFSL[1:0] = 11)					
Output Voltage	-40 to +85 °C, V_{DD} = 1.8–3.8 V	1.62	1.65	1.68	V
VREF Turn-on Time		—	—	1.5	μs
Supply Current	Normal Power Mode Low Power Mode	— —	260 140	— —	μA
External Reference (REFSL[1:0] = 00, REFOE = 0)					
Input Voltage Range		0	—	V_{DD}	V
Input Current	Sample Rate = 300 ksps; V_{REF} = 3.0 V	—	5.25	—	μA

Table 4.15. IREF0 Electrical Characteristics $V_{DD} = 1.8$ to 3.8 V, -40 to $+85$ °C, unless otherwise specified.

Parameter	Conditions	Min	Typ	Max	Units
Static Performance					
Resolution		6			bits
Output Compliance Range	Low Power Mode, Source	0	—	$V_{DD} - 0.4$	V
	High Current Mode, Source	0	—	$V_{DD} - 0.8$	
	Low Power Mode, Sink	0.3	—	V_{DD}	
	High Current Mode, Sink	0.8	—	V_{DD}	
Integral Nonlinearity		—	$<\pm 0.2$	± 1.0	LSB
Differential Nonlinearity		—	$<\pm 0.2$	± 1.0	LSB
Offset Error		—	$<\pm 0.1$	± 0.5	LSB
Full Scale Error	Low Power Mode, Source	—	—	± 5	%
	High Current Mode, Source	—	—	± 6	%
	Low Power Mode, Sink	—	—	± 8	%
	High Current Mode, Sink	—	—	± 8	%
Absolute Current Error	Low Power Mode Sourcing 20 μ A	—	$<\pm 1$	± 3	%
Dynamic Performance					
Output Settling Time to 1/2 LSB		—	300	—	ns
Startup Time		—	1	—	μ s
Power Consumption					
Net Power Supply Current (V_{DD} supplied to IREF0 minus any output source current)	Low Power Mode, Source IREF0DAT = 000001	—	10	—	μ A
	IREF0DAT = 111111	—	10	—	μ A
	High Current Mode, Source IREF0DAT = 000001	—	10	—	μ A
	IREF0DAT = 111111	—	10	—	μ A
	Low Power Mode, Sink IREF0DAT = 000001	—	1	—	μ A
	IREF0DAT = 111111	—	11	—	μ A
	High Current Mode, Sink IREF0DAT = 000001	—	12	—	μ A
	IREF0DAT = 111111	—	81	—	μ A
Note: Refer to “7.1. PWM Enhanced Mode” on page 110 for information on how to improve IREF0 resolution.					

Si102x/3x

Table 4.16. Comparator Electrical Characteristics

$V_{DD} = 1.8$ to 3.8 V, -40 to $+85$ °C unless otherwise noted.

Parameter	Conditions	Min	Typ	Max	Units
Response Time: Mode 0, $V_{DD} = 2.4$ V, $V_{CM}^* = 1.2$ V	CP0+ – CP0– = 100 mV	—	120	—	ns
	CP0+ – CP0– = –100 mV	—	110	—	ns
Response Time: Mode 1, $V_{DD} = 2.4$ V, $V_{CM}^* = 1.2$ V	CP0+ – CP0– = 100 mV	—	180	—	ns
	CP0+ – CP0– = –100 mV	—	220	—	ns
Response Time: Mode 2, $V_{DD} = 2.4$ V, $V_{CM}^* = 1.2$ V	CP0+ – CP0– = 100 mV	—	350	—	ns
	CP0+ – CP0– = –100 mV	—	600	—	ns
Response Time: Mode 3, $V_{DD} = 2.4$ V, $V_{CM}^* = 1.2$ V	CP0+ – CP0– = 100 mV	—	1240	—	ns
	CP0+ – CP0– = –100 mV	—	3200	—	ns
Common-Mode Rejection Ratio		—	1.5	—	mV/V
Inverting or Non-Inverting Input Voltage Range		–0.25	—	$V_{DD} + 0.25$	V
Input Capacitance		—	12	—	pF
Input Bias Current		—	1	—	nA
Input Offset Voltage		–10	—	+10	mV
Power Supply					
Power Supply Rejection		—	0.1	—	mV/V
Power-up Time	$V_{DD} = 3.8$ V	—	0.6	—	μ s
	$V_{DD} = 3.0$ V	—	1.0	—	μ s
	$V_{DD} = 2.4$ V	—	1.8	—	μ s
	$V_{DD} = 1.8$ V	—	10	—	μ s
Supply Current at DC	Mode 0	—	23	—	μ A
	Mode 1	—	8.8	—	μ A
	Mode 2	—	2.6	—	μ A
	Mode 3	—	0.4	—	μ A
*Note: V_{cm} is the common-mode voltage on CP0+ and CP0–.					

Table 4.16. Comparator Electrical Characteristics (Continued) $V_{DD} = 1.8$ to 3.8 V, -40 to $+85$ °C unless otherwise noted.

Parameter	Conditions	Min	Typ	Max	Units
Hysteresis					
Mode 0					
Hysteresis 1	(CPnHYP/N1-0 = 00)	—	0	—	mV
Hysteresis 2	(CPnHYP/N1-0 = 01)	—	8.5	—	mV
Hysteresis 3	(CPnHYP/N1-0 = 10)	—	17	—	mV
Hysteresis 4	(CPnHYP/N1-0 = 11)	—	34	—	mV
Mode 1					
Hysteresis 1	(CPnHYP/N1-0 = 00)	—	0	—	mV
Hysteresis 2	(CPnHYP/N1-0 = 01)	—	6.5	—	mV
Hysteresis 3	(CPnHYP/N1-0 = 10)	—	13	—	mV
Hysteresis 4	(CPnHYP/N1-0 = 11)	—	26	—	mV
Mode 2					
Hysteresis 1	(CPnHYP/N1-0 = 00)	—	0	1	mV
Hysteresis 2	(CPnHYP/N1-0 = 01)	2	5	10	mV
Hysteresis 3	(CPnHYP/N1-0 = 10)	5	10	20	mV
Hysteresis 4	(CPnHYP/N1-0 = 11)	12	20	30	mV
Mode 3					
Hysteresis 1	(CPnHYP/N1-0 = 00)	—	0	—	mV
Hysteresis 2	(CPnHYP/N1-0 = 01)	—	4.5	—	mV
Hysteresis 3	(CPnHYP/N1-0 = 10)	—	9	—	mV
Hysteresis 4	(CPnHYP/N1-0 = 11)	—	17	—	mV
*Note: Vcm is the common-mode voltage on CP0+ and CP0-.					

Table 4.17. VREG0 Electrical Characteristics $V_{DD} = 1.8$ to 3.8 V, -40 to $+85$ °C unless otherwise specified.

Parameter	Conditions	Min	Typ	Max	Units
Input Voltage Range		1.8	—	3.8	V
Bias Current	Normal, idle, suspend, or stop mode	—	20	—	μ A

Si102x/3x

Table 4.18. LCD0 Electrical Characteristics

$V_{DD} = 1.8$ to 3.8 V; $T_A = -40$ to $+85$ °C unless otherwise specified; Using factory-calibrated settings.

Parameter	Conditions	Min	Typ	Max	Units
Charge Pump Output Voltage Error		—	±30	—	mV
LCD Clock Frequency		16	—	33	kHz

Table 4.19. PC0 Electrical Characteristics

$V_{DD} = 1.8$ to 3.8 V; $T_A = -40$ to $+85$ °C unless otherwise specified; Using factory-calibrated settings.

Parameter	Conditions	Min	Typ	Max	Units
Supply Current (25 °C, 2 ms sample rate)	1.8 V	—	145	—	nA
	2.2 V	—	175	—	
	3.0 V	—	235	—	
	3.8 V	—	285	—	

Table 4.20. DC0 (Buck Converter) Electrical Characteristics

$V_{DD} = 1.8$ to 3.8 V; $T_A = -40$ to $+85$ °C unless otherwise specified; Using factory-calibrated settings.

Parameter	Condition	Min	Typ	Max	Units
Input Voltage Range		1.8	—	3.8	V
Input Supply to Output Voltage Differential (for regulation)		0.45	—	—	V
Output Voltage Range	Programmable from 1.8 to 3.5 V	1.8	1.9	3.5	V
Output Power	$V_{DC} = 1.8$ to 3.0 V. $V_{BAT} \geq V_{DC} + 0.5$.	—	—	250	mW
Output Load Current		—	—	85	mA
Inductor Value ¹		0.47	0.56	0.68	μ H
Inductor Current Rating	For load currents less than 50 mA For load currents greater than 50 mA	450 550	— —	— —	mA
Output Capacitor Value ²		1	2.2	10	μ F
Input Capacitor ²		—	4.7	—	μ F
Output Load Current (based on output power specification)	Target output = 1.8 to 3.0 V ³ Target output = 3.1 V ³ Target output = 3.3 V ³ Target output = 3.5 V ⁴	— — — —	— — — —	85^3 70^3 50^3 10^4	mA
Load Regulation	Output = 1.9 V; Load current up-to 85 mA; Supply range = 2.4 – 3.8 V	—	0.03	—	mv/mA
Maximum DC Load Current During Startup		—	—	5	mA
Switching Clock Frequency		1.9	2.9	3.8	MHz
Notes:					
1. Recommended: Inductor similar to NLV32T-R56J-PF (0.56 μ H)					
2. Recommended: X7R or X5R ceramic capacitors with low ESR. Example: Murata GRM21BR71C225K with ESR < 10 m Ω (@ frequency > 1 MHz)					
3. $V_{BAT} \geq V_{DC} + 0.5$. Auto-Bypass enabled (DC0MD.2 = 1).					
4. $V_{BAT} = 3.8$ V. Auto-Bypass disabled (DC0MD.2 = 0).					

4.3. EZRadioPRO® Peripheral Electrical Characteristics

Table 4.21. DC Characteristics¹

Parameter	Symbol	Conditions	Min	Typ	Max	Units
Supply Voltage Range	V _{DD_RF}		1.8	3.0	3.6	V
Power Saving Modes	I _{Shutdown}	RC Oscillator, Main Digital Regulator, and Low Power Digital Regulator OFF	—	15	50	nA
	I _{Standby}	Low Power Digital Regulator ON (Register values retained) and Main Digital Regulator, and RC Oscillator OFF	—	450	800	nA
	I _{Sleep}	RC Oscillator and Low Power Digital Regulator ON (Register values retained) and Main Digital Regulator OFF	—	1	—	μA
	I _{Sensor-LBD}	Main Digital Regulator and Low Battery Detector ON, Crystal Oscillator and all other blocks OFF ²	—	1	—	μA
	I _{Sensor-TS}	Main Digital Regulator and Temperature Sensor ON, Crystal Oscillator and all other blocks OFF ²	—	1	—	μA
	I _{Ready}	Crystal Oscillator and Main Digital Regulator ON, all other blocks OFF. Crystal Oscillator buffer disabled	—	800	—	μA
TUNE Mode Current	I _{Tune}	Synthesizer and regulators enabled	—	8.5	—	mA
RX Mode Current	I _{RX}		—	18.5	—	mA
TX Mode Current Si1020/21/22/23/30/ 31/32/33	I _{TX_+20}	txpow[2:0] = 111 (+20 dBm) Using Silicon Labs' Reference Design. TX current consumption is dependent on match and board layout.	—	85	—	mA
TX Mode Current Si1024/25/26/27/34/ 35/36/37	I _{TX_+13}	txpow[2:0] = 110 (+13 dBm) Using Silicon Labs' Reference Design. TX current consumption is dependent on match and board layout.	—	30	—	mA
	I _{TX_+1}	txpow[2:0] = 010 (+1 dBm) Using Silicon Labs' Reference Design. TX current consumption is dependent on match and board layout.	—	17	—	mA
Notes:						
1. All specification guaranteed by production test unless otherwise noted. Production test conditions and max limits are listed in the "Production Test Conditions" section on page 77.						
2. Guaranteed by qualification. Qualification test conditions are listed in the "Production Test Conditions" section on page 77.						

Table 4.22. Synthesizer AC Electrical Characteristics¹

Parameter	Symbol	Conditions	Min	Typ	Max	Units
Synthesizer Frequency Range	F_{SYN}		240	—	960	MHz
Synthesizer Frequency Resolution ²	$F_{\text{RES-LB}}$	Low Band, 240–480 MHz	—	156.25	—	Hz
	$F_{\text{RES-HB}}$	High Band, 480–960 MHz	—	312.5	—	Hz
Reference Frequency Input Level ²	$f_{\text{REF-LV}}$	When using external reference signal driving XOOUT pin, instead of using crystal. Measured peak-to-peak (V_{PP})	0.7	—	1.6	V
Synthesizer Settling Time ²	t_{LOCK}	Measured from exiting Ready mode with XOSC running to any frequency. Including VCO Calibration.	—	200	—	μs
Residual FM ²	ΔF_{RMS}	Integrated over ± 250 kHz bandwidth (500 Hz lower bound of integration)	—	2	4	kHz_{RMS}
Phase Noise ²	$L\phi(f_M)$	$\Delta F = 10$ kHz	—	–80	—	dBc/Hz
		$\Delta F = 100$ kHz	—	–90	—	dBc/Hz
		$\Delta F = 1$ MHz	—	–115	—	dBc/Hz
		$\Delta F = 10$ MHz	—	–130	—	dBc/Hz

Notes:

1. All specification guaranteed by production test unless otherwise noted. Production test conditions and max limits are listed in the "Production Test Conditions" section on page 77.
2. Guaranteed by qualification. Qualification test conditions are listed in the "Production Test Conditions" section on page 77.

Table 4.23. Receiver AC Electrical Characteristics¹

Parameter	Symbol	Conditions	Min	Typ	Max	Units
RX Frequency Range	F _{RX}		240	—	960	MHz
RX Sensitivity ²	P _{RX_2}	(BER < 0.1%) (2 kbps, GFSK, BT = 0.5, Δf = ±5 kHz) ³	—	-121	—	dBm
	P _{RX_40}	(BER < 0.1%) (40 kbps, GFSK, BT = 0.5, Δf = ±20 kHz) ³	—	-108	—	dBm
	P _{RX_100}	(BER < 0.1%) (100 kbps, GFSK, BT = 0.5, Δf = ±50 kHz) ³	—	-104	—	dBm
	P _{RX_125}	(BER < 0.1%) (125 kbps, GFSK, BT = 0.5, Δf = ±62.5 kHz)	—	-101	—	dBm
	P _{RX_OOK}		(BER < 0.1%) (4.8 kbps, 350 kHz BW, OOK) ³	—	-110	—
(BER < 0.1%) (40 kbps, 400 kHz BW, OOK) ³			—	-102	—	dBm
RX Channel Bandwidth ³	BW		2.6	—	620	kHz
BER Variation vs Power Level ³	P _{RX_RES}	Up to +5 dBm Input Level	—	0	0.1	ppm
LNA Input Impedance ³ (Unmatched—measured differentially across RX input pins)	R _{IN-RX}	915 MHz	—	51–60j	—	Ω
		868 MHz	—	54–63j	—	
		433 MHz	—	89–110j	—	
		315 MHz	—	107–137j	—	
RSSI Resolution	RES _{RSSI}		—	±0.5	—	dB
±1-Ch Offset Selectivity ³	C/I _{1-CH}	Desired Ref Signal 3 dB above sensitivity, BER < 0.1%. Interferer and desired modulated with 40 kbps ΔF = 20 kHz GFSK with BT = 0.5, channel spacing = 150 kHz	—	-31	—	dB
±2-Ch Offset Selectivity ³	C/I _{2-CH}		—	-35	—	dB
≥ ±3-Ch Offset Selectivity ³	C/I _{3-CH}		—	-40	—	dB
Blocking at 1 MHz Offset ³	1M _{BLOCK}	Desired Ref Signal 3 dB above sensitivity. Interferer and desired modulated with 40 kbps ΔF = 20 kHz GFSK with BT = 0.5	—	-52	—	dB
Blocking at 4 MHz Offset ³	4M _{BLOCK}		—	-56	—	dB
Blocking at 8 MHz Offset ³	8M _{BLOCK}		—	-63	—	dB
Image Rejection ³	Im _{REJ}	Rejection at the image frequency. IF=937 kHz	—	-30	—	dB
Spurious Emissions ³	P _{OB_RX1}	Measured at RX pins	—	—	-54	dBm

Notes:

1. All specification guaranteed by production test unless otherwise noted. Production test conditions and max limits are listed in the "Production Test Conditions" section on page 77.
2. Receive sensitivity at multiples of 30 MHz may be degraded. If channels with a multiple of 30 MHz are required it is recommended to shift the crystal frequency. Contact Silicon Labs Applications Support for recommendations.
3. Guaranteed by qualification. Qualification test conditions are listed in the "Production Test Conditions" section on page 77.

Table 4.24. Transmitter AC Electrical Characteristics¹

Parameter	Symbol	Conditions	Min	Typ	Max	Units
TX Frequency Range	F_{TX}		240	—	960	MHz
FSK Data Rate ²	DR_{FSK}		0.123	—	256	kbps
OOK Data Rate ²	DR_{OOK}		0.123	—	40	kbps
Modulation Deviation	Δf_1	860–960 MHz	± 0.625		± 320	kHz
	Δf_2	240–860 MHz	± 0.625		± 160	kHz
Modulation Deviation Resolution ²	Δf_{RES}		—	0.625	—	kHz
Output Power Range— Si1020/21/22/23/30/31/32/33 ³	P_{TX}		+1	—	+20	dBm
Output Power Range— Si1024/25/26/27/34/35/36/37 ³	P_{TX}		-4	—	+13	dBm
TX RF Output Steps ²	ΔP_{RF_OUT}	controlled by txpow[2:0]	—	3	—	dB
TX RF Output Level ² Variation vs. Temperature	ΔP_{RF_TEMP}	-40 to +85 °C	—	2	—	dB
TX RF Output Level Variation vs. Frequency ²	ΔP_{RF_FREQ}	Measured across any one frequency band	—	1	—	dB
Transmit Modulation Filtering ²	B*T	Gaussian Filtering Band- with Time Product	—	0.5	—	
Spurious Emissions ²	P_{OB-TX1}	$P_{OUT} = 11$ dBm, Frequencies <1 GHz	—	—	-54	dBm
	P_{OB-TX2}	1–12.75 GHz, excluding harmonics	—	—	-54	dBm
Harmonics ²	P_{2HARM}	Using reference design TX matching network and filter with max output power. Har- monics reduce linearly with output power.	—	—	-42	dBm
	P_{3HARM}		—	—	-42	dBm

Notes:

1. All specification guaranteed by production test unless otherwise noted. Production test conditions and max limits are listed in the "Production Test Conditions" section on page 77.
2. Guaranteed by qualification. Qualification test conditions are listed in the "Production Test Conditions" section on page 77.
3. Output power is dependent on matching components, board layout, and is measured at the pin.

Si102x/3x

Table 4.25. Auxiliary Block Specifications¹

Parameter	Symbol	Conditions	Min	Typ	Max	Units
Temperature Sensor Accuracy ²	TS _A	After calibrated via sensor offset register tvoffs[7:0]	—	0.5	—	°C
Temperature Sensor Sensitivity ²	TS _S		—	5	—	mV/°C
Low Battery Detector Resolution ²	LBD _{RES}		—	50	—	mV
Low Battery Detector Conversion Time ²	LBD _{CT}		—	250	—	μs
Microcontroller Clock Output Frequency	F _{MC}	Configurable to 30 MHz, 15 MHz, 10 MHz, 4 MHz, 3 MHz, 2 MHz, 1 MHz, or 32.768 kHz	32.768k	—	30M	Hz
General Purpose ADC Resolution ²	ADC _{ENB}		—	8	—	bit
General Purpose ADC Bit Resolution ²	ADC _{RES}		—	4	—	mV/bit
Temp Sensor & General Purpose ADC Conversion Time ²	ADC _{CT}		—	305	—	μs
30 MHz XTAL Start-Up time	t _{30M}	Using XTAL and board layout in reference design. Start-up time will vary with XTAL type and board layout.	—	600	—	μs
30 MHz XTAL Cap Resolution ²	30M _{RES}	See “32.5.8. Crystal Oscillator” on page 464 for the total load capacitance calculation	—	97	—	fF
32 kHz XTAL Start-Up Time ²	t _{32k}		—	6	—	sec
32 kHz Accuracy using Internal RC Oscillator ²	32KRC _{RES}		—	1000	—	ppm
32 kHz RC Oscillator Start-Up	t _{32kRC}		—	500	—	μs
POR Reset Time	t _{POR}	Current consumption during POR time is 200 μA typical	—	9.5	—	ms
Software Reset Time ²	t _{soft}		—	250	—	μs
Notes:						
1. All specification guaranteed by production test unless otherwise noted. Production test conditions and max limits are listed in the "Production Test Conditions" section on page 77.						
2. Guaranteed by qualification. Qualification test conditions are listed in the "Production Test Conditions" section on page 77.						

Table 4.26. Digital IO Specifications (nIRQ)

Parameter	Symbol	Conditions	Min	Typ	Max	Units
Rise Time	T_{RISE}	$0.1 \times V_{DD_RF}$ to $0.9 \times V_{DD_RF}$, $C_L = 5 \text{ pF}$	—	—	8	ns
Fall Time	T_{FALL}	$0.9 \times V_{DD_RF}$ to $0.1 \times V_{DD_RF}$, $C_L = 5 \text{ pF}$	—	—	8	ns
Input Capacitance	C_{IN}		—	—	1	pF
Logic High Level Input Voltage	V_{IH}		$V_{DD_RF} - 0.6$	—	—	V
Logic Low Level Input Voltage	V_{IL}		—	—	0.6	V
Input Current	I_{IN}	$0 < V_{IN} < V_{DD_RF}$	-100	—	100	nA
Logic High Level Output Voltage	V_{OH}	$I_{OH} < 1 \text{ mA}$ source, $V_{DD_RF} = 1.8 \text{ V}$	$V_{DD_RF} - 0.6$	—	—	V
Logic Low Level Output Voltage	V_{OL}	$I_{OL} < 1 \text{ mA}$ sink, $V_{DD_RF} = 1.8 \text{ V}$	—	—	0.6	V

Note: All specifications guaranteed by qualification. Qualification test conditions are listed in the "Production Test Conditions" section on page 77.

Table 4.27. GPIO Specifications (GPIO_0, GPIO_1, and GPIO_2)

Parameter	Symbol	Conditions	Min	Typ	Max	Units
Rise Time	T_{RISE}	$0.1 \times V_{DD_RF}$ to $0.9 \times V_{DD_RF}$, $C_L = 10 \text{ pF}$, $DRV < 1:0 > = HH$	—	—	8	ns
Fall Time	T_{FALL}	$0.9 \times V_{DD_RF}$ to $0.1 \times V_{DD_RF}$, $C_L = 10 \text{ pF}$, $DRV < 1:0 > = HH$	—	—	8	ns
Input Capacitance	C_{IN}		—	—	1	pF
Logic High Level Input Voltage	V_{IH}		$V_{DD_RF} - 0.6$	—	—	V
Logic Low Level Input Voltage	V_{IL}		—	—	0.6	V
Input Current	I_{IN}	$0 < V_{IN} < V_{DD_RF}$	-100	—	100	nA
Input Current If Pul- lup is Activated	I_{INP}	$V_{IL} = 0 \text{ V}$	5	—	25	μA
Maximum Output Current	I_{OmaxLL}	$DRV < 1:0 > = LL$	0.1	0.5	0.8	mA
	I_{OmaxLH}	$DRV < 1:0 > = LH$	0.9	2.3	3.5	mA
	I_{OmaxHL}	$DRV < 1:0 > = HL$	1.5	3.1	4.8	mA
	I_{OmaxHH}	$DRV < 1:0 > = HH$	1.8	3.6	5.4	mA
Logic High Level Output Voltage	V_{OH}	$I_{OH} < I_{Omax}$ source, $V_{DD_RF} = 1.8 \text{ V}$	$V_{DD_RF} - 0.6$	—	—	V
Logic Low Level Output Voltage	V_{OL}	$I_{OL} < I_{Omax}$ sink, $V_{DD_RF} = 1.8 \text{ V}$	—	—	0.6	V

Note: All specifications guaranteed by qualification. Qualification test conditions are listed in the "Production Test Conditions" section on page 77.

Si102x/3x

Table 4.28. Absolute Maximum Ratings

Parameter	Value	Unit
V_{DD_RF} to GND	-0.3, +3.6	V
Instantaneous V_{RF_peak} to GND on TX Output Pin	-0.3, +8.0	V
Sustained V_{RF_peak} to GND on TX Output Pin	-0.3, +6.5	V
Voltage on Digital Control Inputs	-0.3, $V_{DD_RF} + 0.3$	V
Voltage on Analog Inputs	-0.3, $V_{DD_RF} + 0.3$	V
RX Input Power	+10	dBm
Operating Ambient Temperature Range T_A	-40 to +85	°C
Thermal Impedance θ_{JA}	30	°C/W
Junction Temperature T_J	+125	°C
Storage Temperature Range T_{STG}	-55 to +125	°C
Note: Stresses beyond those listed under “Absolute Maximum Ratings” may cause permanent damage to the device. These are stress ratings only and functional operation of the device at or beyond these ratings in the operational sections of the specifications is not implied. Exposure to absolute maximum rating conditions for extended periods may affect device reliability. Power Amplifier may be damaged if switched on without proper load or termination connected. TX matching network design will influence TX VRF-peak on TX output pin. Caution: ESD sensitive device.		

4.4. Definition of Test Conditions for the EZRadioPRO Peripheral

Production Test Conditions:

- $T_A = +25\text{ °C}$
- $V_{DD} = +3.3\text{ VDC}$
- Sensitivity measured at 919 MHz
- TX output power measured at 915 MHz
- External reference signal (XOUT) = 1.0 V_{PP} at 30 MHz, centered around 0.8 VDC
- Production test schematic (unless noted otherwise)
- All RF input and output levels referred to the pins of the Si102x/3x (not the RF module)

Qualification Test Conditions:

- $T_A = -40\text{ to }+85\text{ °C}$
- $V_{DD_RF} = +1.8\text{ to }+3.6\text{ VDC}$
- Using reference design or production test schematic
- All RF input and output levels referred to the pins of the Si102x/3x (not the RF module)

5. SAR ADC with 16-bit Auto-Averaging Accumulator and Autonomous Low Power Burst Mode

The ADC0 on Si102x/3x devices is a 300 ksp/s, 10-bit or 75 ksp/s, 12-bit successive-approximation-register (SAR) ADC with integrated track-and-hold and programmable window detector. ADC0 also has an autonomous low power Burst Mode which can automatically enable ADC0, capture and accumulate samples, then place ADC0 in a low power shutdown mode without CPU intervention. It also has a 16-bit accumulator that can automatically oversample and average the ADC results. See Section 5.4 for more details on using the ADC in 12-bit mode.

The ADC is fully configurable under software control via Special Function Registers. The ADC0 operates in Single-ended mode and may be configured to measure various different signals using the analog multiplexer described in “5.7. ADC0 Analog Multiplexer” on page 95. The voltage reference for the ADC is selected as described in “5.9. Voltage and Ground Reference Options” on page 100.

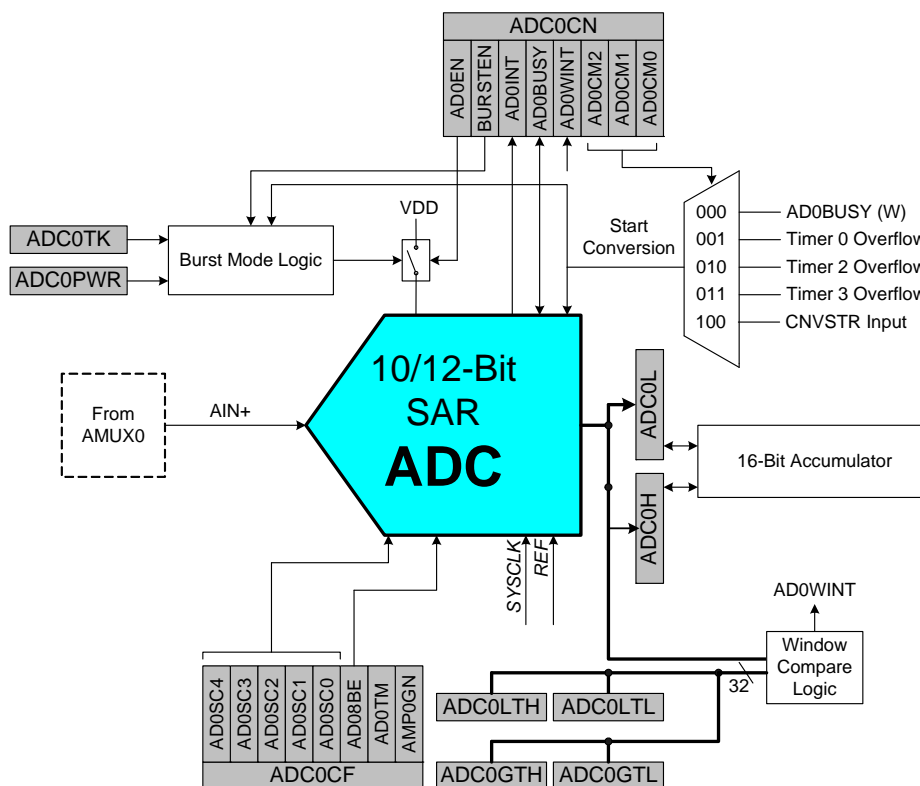

Figure 5.1. ADC0 Functional Block Diagram

5.1. Output Code Formatting

The registers ADC0H and ADC0L contain the high and low bytes of the output conversion code from the ADC at the completion of each conversion. Data can be right-justified or left-justified, depending on the setting of the AD0SJUST[2:0]. When the repeat count is set to 1, conversion codes are represented as 10-bit unsigned integers. Inputs are measured from 0 to VREF x 1023/1024. Example codes are shown below for both right-justified and left-justified data. Unused bits in the ADC0H and ADC0L registers are set to 0.

Input Voltage	Right-Justified ADC0H:ADC0L (AD0SJST = 000)	Left-Justified ADC0H:ADC0L (AD0SJST = 100)
$V_{REF} \times 1023/1024$	0x03FF	0xFFC0
$V_{REF} \times 512/1024$	0x0200	0x8000
$V_{REF} \times 256/1024$	0x0100	0x4000
0	0x0000	0x0000

When the repeat count is greater than 1, the output conversion code represents the accumulated result of the conversions performed and is updated after the last conversion in the series is finished. Sets of 4, 8, 16, 32, or 64 consecutive samples can be accumulated and represented in unsigned integer format. The repeat count can be selected using the AD0RPT bits in the ADC0AC register. When a repeat count higher than 1, the ADC output must be right-justified (AD0SJST = 0xx); unused bits in the ADC0H and ADC0L registers are set to 0. The example below shows the right-justified result for various input voltages and repeat counts. Notice that accumulating 2^n samples is equivalent to left-shifting by n bit positions when all samples returned from the ADC have the same value.

Input Voltage	Repeat Count = 4	Repeat Count = 16	Repeat Count = 64
$V_{REF} \times 1023/1024$	0x0FFC	0x3FF0	0xFFC0
$V_{REF} \times 512/1024$	0x0800	0x2000	0x8000
$V_{REF} \times 511/1024$	0x07FC	0x1FF0	0x7FC0
0	0x0000	0x0000	0x0000

The AD0SJST bits can be used to format the contents of the 16-bit accumulator. The accumulated result can be shifted right by 1, 2, or 3 bit positions. Based on the principles of oversampling and averaging, the effective ADC resolution increases by 1 bit each time the oversampling rate is increased by a factor of 4. The example below shows how to increase the effective ADC resolution by 1, 2, and 3 bits to obtain an effective ADC resolution of 11-bit, 12-bit, or 13-bit respectively without CPU intervention.

Input Voltage	Repeat Count = 4 Shift Right = 1 11-Bit Result	Repeat Count = 16 Shift Right = 2 12-Bit Result	Repeat Count = 64 Shift Right = 3 13-Bit Result
$V_{REF} \times 1023/1024$	0x07F7	0x0FFC	0x1FF8
$V_{REF} \times 512/1024$	0x0400	0x0800	0x1000
$V_{REF} \times 511/1024$	0x03FE	0x04FC	0x0FF8
0	0x0000	0x0000	0x0000

5.2. Modes of Operation

ADC0 has a maximum conversion speed of 300 ksps in 10-bit mode. The ADC0 conversion clock (SAR-CLK) is a divided version of the system clock when burst mode is disabled (BURSTEN = 0), or a divided version of the low power oscillator when burst mode is enabled (BURSEN = 1). The clock divide value is determined by the AD0SC bits in the ADC0CF register.

5.2.1. Starting a Conversion

A conversion can be initiated in one of five ways, depending on the programmed states of the ADC0 Start of Conversion Mode bits (AD0CM2–0) in register ADC0CN. Conversions may be initiated by one of the following:

1. Writing a 1 to the AD0BUSY bit of register ADC0CN
2. A Timer 0 overflow (i.e., timed continuous conversions)
3. A Timer 2 overflow
4. A Timer 3 overflow
5. A rising edge on the CNVSTR input signal (pin P0.6)

Writing a 1 to AD0BUSY provides software control of ADC0 whereby conversions are performed "on-demand". During conversion, the AD0BUSY bit is set to logic 1 and reset to logic 0 when the conversion is complete. The falling edge of AD0BUSY triggers an interrupt (when enabled) and sets the ADC0 interrupt flag (AD0INT). When polling for ADC conversion completions, the ADC0 interrupt flag (AD0INT) should be used. Converted data is available in the ADC0 data registers, ADC0H:ADC0L, when bit AD0INT is logic 1. When Timer 2 or Timer 3 overflows are used as the conversion source, Low Byte overflows are used if Timer 2/3 is in 8-bit mode; High byte overflows are used if Timer 2/3 is in 16-bit mode. See "33. Timers" on page 491 for timer configuration.

Important Note About Using CNVSTR: The CNVSTR input pin also functions as Port pin P0.6. When the CNVSTR input is used as the ADC0 conversion source, Port pin P0.6 should be skipped by the Digital Crossbar. To configure the Crossbar to skip P0.6, set to 1 Bit 6 in register P0SKIP. See "27. Port Input/Output" on page 358 for details on Port I/O configuration.

5.2.2. Tracking Modes

Each ADC0 conversion must be preceded by a minimum tracking time in order for the converted result to be accurate. The minimum tracking time is given in Table 4.12. The AD0TM bit in register ADC0CN controls the ADC0 track-and-hold mode. In its default state when Burst Mode is disabled, the ADC0 input is continuously tracked, except when a conversion is in progress. When the AD0TM bit is logic 1, ADC0 operates in low-power track-and-hold mode. In this mode, each conversion is preceded by a tracking period of 3 SAR clocks (after the start-of-conversion signal). When the CNVSTR signal is used to initiate conversions in low-power tracking mode, ADC0 tracks only when CNVSTR is low; conversion begins on the rising edge of CNVSTR (see Figure 5.2). Tracking can also be disabled (shutdown) when the device is in low power standby or sleep modes. Low-power track-and-hold mode is also useful when AMUX settings are frequently changed, due to the settling time requirements described in "5.2.4. Settling Time Requirements" on page 83.

A. ADC0 Timing for External Trigger Source

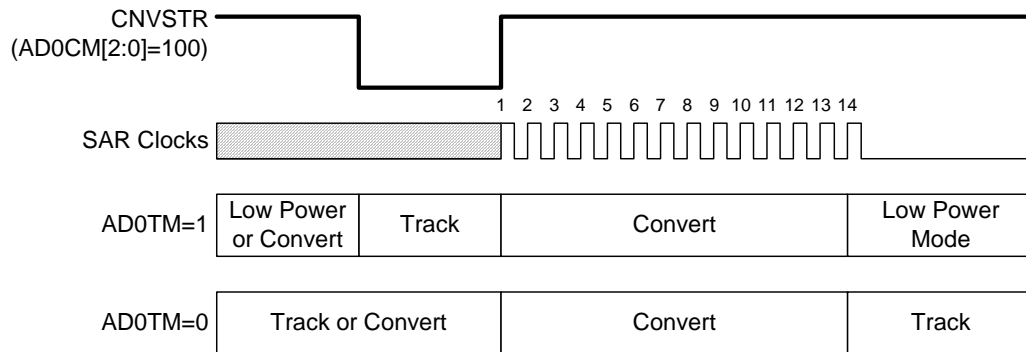

B. ADC0 Timing for Internal Trigger Source

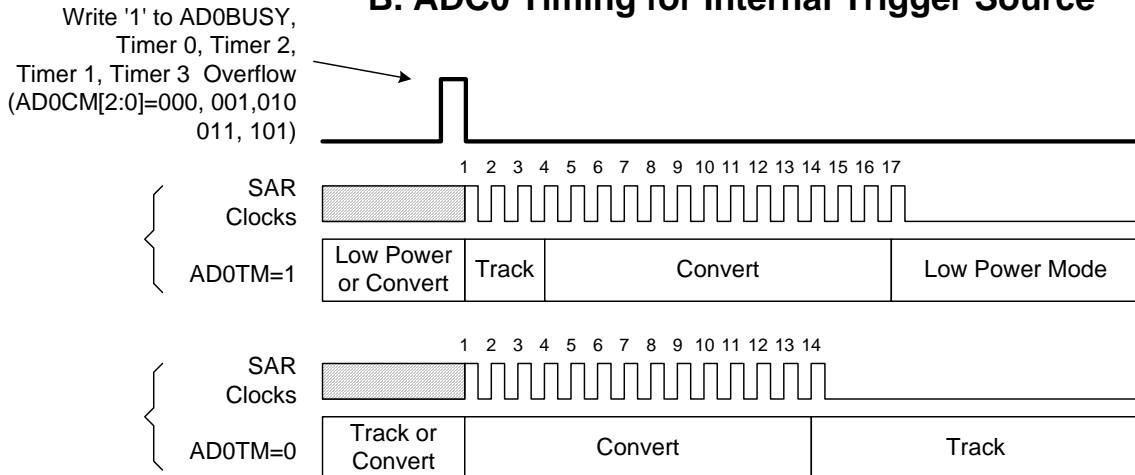

Figure 5.2. 10-Bit ADC Track and Conversion Example Timing (BURSTEN = 0)

Si102x/3x

5.2.3. Burst Mode

Burst Mode is a power saving feature that allows ADC0 to remain in a low power state between conversions. When Burst Mode is enabled, ADC0 wakes from a low power state, accumulates 1, 4, 8, 16, 32, or 64 using an internal Burst Mode clock (approximately 20 MHz), then re-enters a low power state. Since the Burst Mode clock is independent of the system clock, ADC0 can perform multiple conversions then enter a low power state within a single system clock cycle, even if the system clock is slow (e.g. 32.768 kHz), or suspended.

Burst Mode is enabled by setting BURSTEN to logic 1. When in Burst Mode, AD0EN controls the ADC0 idle power state (i.e. the state ADC0 enters when not tracking or performing conversions). If AD0EN is set to logic 0, ADC0 is powered down after each burst. If AD0EN is set to logic 1, ADC0 remains enabled after each burst. On each convert start signal, ADC0 is awakened from its Idle Power State. If ADC0 is powered down, it will automatically power up and wait the programmable Power-Up Time controlled by the AD0PWR bits. Otherwise, ADC0 will start tracking and converting immediately. Figure 5.3 shows an example of Burst Mode Operation with a slow system clock and a repeat count of 4.

When Burst Mode is enabled, a single convert start will initiate a number of conversions equal to the repeat count. When Burst Mode is disabled, a convert start is required to initiate each conversion. In both modes, the ADC0 End of Conversion Interrupt Flag (AD0INT) will be set after “repeat count” conversions have been accumulated. Similarly, the Window Comparator will not compare the result to the greater-than and less-than registers until “repeat count” conversions have been accumulated.

In Burst Mode, tracking is determined by the settings in AD0PWR and AD0TK. The default settings for these registers will work in most applications without modification; however, settling time requirements may need adjustment in some applications. Refer to “5.2.4. Settling Time Requirements” on page 83 for more details.

Notes:

- Setting AD0TM to 1 will insert an additional 3 SAR clocks of tracking before each conversion, regardless of the settings of AD0PWR and AD0TK.
- When using Burst Mode, care must be taken to issue a convert start signal no faster than once every four SYSCLK periods. This includes external convert start signals.

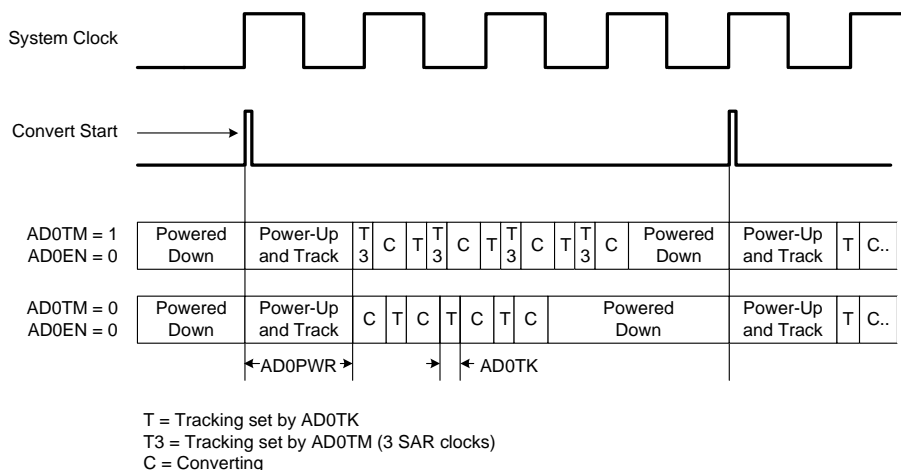

Figure 5.3. Burst Mode Tracking Example with Repeat Count Set to 4

5.2.4. Settling Time Requirements

A minimum amount of tracking time is required before each conversion can be performed, to allow the sampling capacitor voltage to settle. This tracking time is determined by the AMUX0 resistance, the ADC0 sampling capacitance, any external source resistance, and the accuracy required for the conversion. Note that in low-power tracking mode, three SAR clocks are used for tracking at the start of every conversion. For many applications, these three SAR clocks will meet the minimum tracking time requirements, and higher values for the external source impedance will increase the required tracking time.

Figure 5.4 shows the equivalent ADC0 input circuit. The required ADC0 settling time for a given settling accuracy (SA) may be approximated by Equation . When measuring the Temperature Sensor output or V_{DD} with respect to GND, R_{TOTAL} reduces to R_{MUX} . See Table 4.12 for ADC0 minimum settling time requirements as well as the mux impedance and sampling capacitor values.

$$t = \ln\left(\frac{2^n}{SA}\right) \times R_{TOTAL} C_{SAMPLE}$$

ADC0 Settling Time Requirements

Where:

SA is the settling accuracy, given as a fraction of an LSB (for example, 0.25 to settle within 1/4 LSB)

t is the required settling time in seconds

R_{TOTAL} is the sum of the AMUX0 resistance and any external source resistance.

n is the ADC resolution in bits (10).

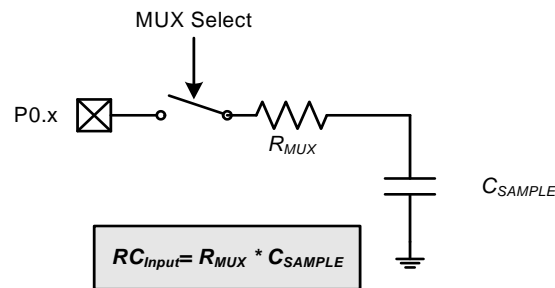

Note: The value of CSAMPLE depends on the PGA Gain. See Table 4.12 for details.

Figure 5.4. ADC0 Equivalent Input Circuits

5.2.5. Gain Setting

The ADC has gain settings of 1x and 0.5x. In 1x mode, the full scale reading of the ADC is determined directly by V_{REF} . In 0.5x mode, the full-scale reading of the ADC occurs when the input voltage is $V_{REF} \times 2$. The 0.5x gain setting can be useful to obtain a higher input Voltage range when using a small V_{REF} voltage, or to measure input voltages that are between V_{REF} and V_{DD} . Gain settings for the ADC are controlled by the AMP0GN bit in register ADC0CF.

Si102x/3x

5.3. 8-Bit Mode

Setting the ADC08BE bit in register ADC0CF to 1 will put the ADC in 8-bit mode. In 8-bit mode, only the 8 MSBs of data are converted, allowing the conversion to be completed in two fewer SAR clock cycles than a 10-bit conversion. This can result in an overall lower power consumption since the system can spend more time in a low power mode. The two LSBs of a conversion are always 00 in this mode, and the ADC0L register will always read back 0x00.

5.4. 12-Bit Mode

Si102x/3x devices have an enhanced SAR converter that provides 12-bit resolution while retaining the 10- and 8-bit operating modes of the other devices in the family. When configured for 12-bit conversions, the ADC performs four 10-bit conversions using four different reference voltages and combines the results into a single 12-bit value. Unlike simple averaging techniques, this method provides true 12-bit resolution of AC or DC input signals without depending on noise to provide dithering. The converter also employs a hardware Dynamic Element Matching algorithm that reconfigures the largest elements of the internal DAC for each of the four 10-bit conversions to cancel the any matching errors, enabling the converter to achieve 12-bit linearity performance to go along with its 12-bit resolution. For best performance, the Low Power Oscillator should be selected as the system clock source while taking 12-bit ADC measurements.

The 12-bit mode is enabled by setting the AD012BE bit (ADC0AC.7) to logic 1 and configuring Burst Mode for four conversions as described in Section 5.2.3. The conversion can be initiated using any of the methods described in Section 5.2.1, and the 12-bit result will appear in the ADC0H and ADC0L registers. Since the 12-bit result is formed from a combination of four 10-bit results, the maximum output value is $4 \times (1023) = 4092$, rather than the max value of $(2^{12} - 1) = 4095$ that is produced by a traditional 12-bit converter. To further increase resolution, the burst mode repeat value may be configured to any multiple of four conversions. For example, if a repeat value of 16 is selected, the ADC0 output will be a 14-bit number (sum of four 12-bit numbers) with 13 effective bits of resolution.

5.5. Low Power Mode

The SAR converter provides a low power mode that allows a significant reduction in operating current when operating at low SAR clock frequencies. Low power mode is enabled by setting the AD0LPM bit (ADC0PWR.7) to 1. In general, low power mode is recommended when operating with SAR conversion clock frequency at 4 MHz or less. See the Electrical Characteristics chapter for details on power consumption and the maximum clock frequencies allowed in each mode. Setting the Low Power Mode bit reduces the bias currents in both the SAR converter and in the High-Speed Voltage Reference.

Table 5.1. Representative Conversion Times and Energy Consumption for the SAR ADC with 1.65 V High-Speed VREF

	Normal Power Mode			Low Power Mode		
	8 bit	10 bit	12 bit	8 bit	10 bit	12 bit
Highest nominal SAR clock frequency	8.17 MHz (24.5/3)	8.17 MHz (24.5/3)	6.67 MHz (20.0/3)	4.08 MHz (24.5/6)	4.08 MHz (24.5/6)	4.00 MHz (20.0/5)
Total number of conversion clocks required	11	13	52 (13 x 4)	11	13	52 (13*4)
Total tracking time (min)	1.5 μ s	1.5 μ s	4.8 μ s (1.5+3 x 1.1)	1.5 μ s	1.5 μ s	4.8 μ s (1.5+3 x 1.1)
Total time for one conversion	2.85 μ s	3.09 μ s	12.6 μ s	4.19 μ s	4.68 μ s	17.8 μ s
ADC Throughput	351 ksps	323 ksps	79 ksps	238 ksps	214 ksps	56 ksps
Energy per conversion	8.2 nJ	8.9 nJ	36.5 nJ	6.5 nJ	7.3 nJ	27.7 nJ
<p>Note: This table assumes that the 24.5 MHz precision oscillator is used for 8- and 10-bit modes, and the 20 MHz low power oscillator is used for 12-bit mode. The values in the table assume that the oscillators run at their nominal frequencies. The maximum SAR clock values given in Table 4.12 allow for maximum oscillation frequencies of 25.0 MHz and 22 MHz for the precision and low-power oscillators, respectively, when using the given SAR clock divider values. Energy calculations are for the ADC subsystem only and do not include CPU current.</p>						

Si102x/3x

SFR Definition 5.1. ADC0CN: ADC0 Control

Bit	7	6	5	4	3	2	1	0
Name	AD0EN	BURSTEN	AD0INT	AD0BUSY	AD0WINT	ADC0CM[2:0]		
Type	R/W	R/W	R/W	W	R/W	R/W		
Reset	0	0	0	0	0	0	0	0

SFR Page = All Pages; SFR Address = 0xE8; bit-addressable;

Bit	Name	Function
7	AD0EN	ADC0 Enable. 0: ADC0 Disabled (low-power shutdown). 1: ADC0 Enabled (active and ready for data conversions).
6	BURSTEN	ADC0 Burst Mode Enable. 0: ADC0 Burst Mode Disabled. 1: ADC0 Burst Mode Enabled.
5	AD0INT	ADC0 Conversion Complete Interrupt Flag. Set by hardware upon completion of a data conversion (BURSTEN=0), or a burst of conversions (BURSTEN=1). Can trigger an interrupt. Must be cleared by software.
4	AD0BUSY	ADC0 Busy. Writing 1 to this bit initiates an ADC conversion when ADC0CM[2:0] = 000.
3	AD0WINT	ADC0 Window Compare Interrupt Flag. Set by hardware when the contents of ADC0H:ADC0L fall within the window specified by ADC0GTH:ADC0GTL and ADC0LTH:ADC0LTL. Can trigger an interrupt. Must be cleared by software.
2:0	ADC0CM[2:0]	ADC0 Start of Conversion Mode Select. Specifies the ADC0 start of conversion source. 000: ADC0 conversion initiated on write of 1 to AD0BUSY. 001: ADC0 conversion initiated on overflow of Timer 0. 010: ADC0 conversion initiated on overflow of Timer 2. 011: ADC0 conversion initiated on overflow of Timer 3. 1xx: ADC0 conversion initiated on rising edge of CNVSTR.

SFR Definition 5.2. ADC0CF: ADC0 Configuration

Bit	7	6	5	4	3	2	1	0
Name	AD0SC[4:0]					AD08BE	AD0TM	AMP0GN
Type	R/W					R/W	R/W	R/W
Reset	1	1	1	1	1	0	0	0

SFR Page = 0x0; SFR Address = 0xBC

Bit	Name	Function
7:3	AD0SC[4:0]	<p>ADC0 SAR Conversion Clock Divider.</p> <p>SAR Conversion clock is derived from FCLK by the following equation, where AD0SC refers to the 5-bit value held in bits AD0SC[4:0]. SAR Conversion clock requirements are given in Table 4.12.</p> <p>BURSTEN = 0: FCLK is the current system clock.</p> <p>BURSTEN = 1: FCLK is the 20 MHz low power oscillator, independent of the system clock.</p> $AD0SC = \frac{FCLK}{CLK_{SAR}} - 1 *$ <p>*Round the result up.</p> <p>or</p> $CLK_{SAR} = \frac{FCLK}{AD0SC + 1}$
2	AD08BE	<p>ADC0 8-Bit Mode Enable.</p> <p>0: ADC0 operates in 10-bit mode (normal operation).</p> <p>1: ADC0 operates in 8-bit mode.</p>
1	AD0TM	<p>ADC0 Track Mode.</p> <p>Selects between Normal or Delayed Tracking Modes.</p> <p>0: Normal Track Mode: When ADC0 is enabled, conversion begins immediately following the start-of-conversion signal.</p> <p>1: Delayed Track Mode: When ADC0 is enabled, conversion begins 3 SAR clock cycles following the start-of-conversion signal. The ADC is allowed to track during this time.</p>
0	AMP0GN	<p>ADC0 Gain Control.</p> <p>0: The on-chip PGA gain is 0.5.</p> <p>1: The on-chip PGA gain is 1.</p>

SFR Definition 5.3. ADC0AC: ADC0 Accumulator Configuration

Bit	7	6	5	4	3	2	1	0
Name	AD012BE	AD0AE	AD0SJST[2:0]			AD0RPT[2:0]		
Type	R/W	W	R/W			R/W		
Reset	0	0	0	0	0	0	0	0

SFR Page = 0x0; SFR Address = 0xBA

Bit	Name	Function
7	AD012BE	<p>ADC0 12-Bit Mode Enable.</p> <p>Enables 12-bit Mode. 0: 12-bit Mode Disabled. 1: 12-bit Mode Enabled.</p>
6	AD0AE	<p>ADC0 Accumulate Enable.</p> <p>Enables multiple conversions to be accumulated when burst mode is disabled. 0: ADC0H:ADC0L contain the result of the latest conversion when Burst Mode is disabled. 1: ADC0H:ADC0L contain the accumulated conversion results when Burst Mode is disabled. Software must write 0x0000 to ADC0H:ADC0L to clear the accumulated result. This bit is write-only. Always reads 0b.</p>
5:3	AD0SJST[2:0]	<p>ADC0 Accumulator Shift and Justify.</p> <p>Specifies the format of data read from ADC0H:ADC0L. 000: Right justified. No shifting applied. 001: Right justified. Shifted right by 1 bit. 010: Right justified. Shifted right by 2 bits. 011: Right justified. Shifted right by 3 bits. 100: Left justified. No shifting applied. All remaining bit combinations are reserved.</p>
2:0	AD0RPT[2:0]	<p>ADC0 Repeat Count.</p> <p>Selects the number of conversions to perform and accumulate in Burst Mode. This bit field must be set to 000 if Burst Mode is disabled. 000: Perform and Accumulate 1 conversion. 001: Perform and Accumulate 4 conversions. 010: Perform and Accumulate 8 conversions. 011: Perform and Accumulate 16 conversions. 100: Perform and Accumulate 32 conversions. 101: Perform and Accumulate 64 conversions. All remaining bit combinations are reserved.</p>

SFR Definition 5.4. ADC0PWR: ADC0 Burst Mode Power-Up Time

Bit	7	6	5	4	3	2	1	0
Name	AD0LPM				AD0PWR[3:0]			
Type	R/W	R	R	R	R/W			
Reset	0	0	0	0	1	1	1	1

SFR Page = 0xF; SFR Address = 0xBA

Bit	Name	Function
7	AD0LPM	ADC0 Low Power Mode Enable. Enables Low Power Mode Operation. 0: Low Power Mode disabled. 1: Low Power Mode enabled.
6:4	Unused	Read = 0000b; Write = Don't Care.
3:0	AD0PWR[3:0]	ADC0 Burst Mode Power-Up Time. Sets the time delay required for ADC0 to power up from a low power state. For BURSTEN = 0: ADC0 power state controlled by AD0EN. For BURSTEN = 1 and AD0EN = 1: ADC0 remains enabled and does not enter a low power state after all conversions are complete. Conversions can begin immediately following the start-of-conversion signal. For BURSTEN = 1 and AD0EN = 0: ADC0 enters a low power state after all conversions are complete. Conversions can begin a programmed delay after the start-of-conversion signal. The ADC0 Burst Mode Power-Up time is programmed according to the following equation: $AD0PWR = \frac{T_{startup}}{400ns} - 1$ <p>or</p> $T_{startup} = (AD0PWR + 1)400ns$ Note: Setting AD0PWR to 0x04 provides a typical tracking time of 2 us for the first sample taken after the start of conversion.

SFR Definition 5.5. ADC0TK: ADC0 Burst Mode Track Time

Bit	7	6	5	4	3	2	1	0
Name	AD0TK[5:0]							
Type	R	R	R/W					
Reset	0	0	0	1	1	1	1	0

SFR Page = 0xF; SFR Address = 0xBB

Bit	Name	Function
7	Reserved	Read = 0b; Write = Must Write 0b.
6	Unused	Read = 0b; Write = Don't Care.
5:0	AD0TK[5:0]	<p>ADC0 Burst Mode Track Time. Sets the time delay between consecutive conversions performed in Burst Mode.</p> <p>The ADC0 Burst Mode Track time is programmed according to the following equation:</p> $AD0TK = 63 - \left(\frac{T_{track}}{50ns} - 1 \right)$ <p>or</p> $T_{track} = (64 - AD0TK)50ns$

Notes:

1. If AD0TM is set to 1, an additional 3 SAR clock cycles of Track time will be inserted prior to starting the conversion.
2. The Burst Mode Track delay is not inserted prior to the first conversion. The required tracking time for the first conversion should be met by the Burst Mode Power-Up Time.

SFR Definition 5.6. ADC0H: ADC0 Data Word High Byte

Bit	7	6	5	4	3	2	1	0
Name	ADC0[15:8]							
Type	R/W							
Reset	0	0	0	0	0	0	0	0

SFR Page = 0x0; SFR Address = 0xBE

Bit	Name	Description	Read	Write
7:0	ADC0[15:8]	ADC0 Data Word High Byte.	Most Significant Byte of the 16-bit ADC0 Accumulator formatted according to the settings in AD0SJST[2:0].	Set the most significant byte of the 16-bit ADC0 Accumulator to the value written.
Note: If Accumulator shifting is enabled, the most significant bits of the value read will be zeros. This register should not be written when the SYNC bit is set to 1.				

SFR Definition 5.7. ADC0L: ADC0 Data Word Low Byte

Bit	7	6	5	4	3	2	1	0
Name	ADC0[7:0]							
Type	R/W							
Reset	0	0	0	0	0	0	0	0

SFR Page = 0x0; SFR Address = 0xBD;

Bit	Name	Description	Read	Write
7:0	ADC0[7:0]	ADC0 Data Word Low Byte.	Least Significant Byte of the 16-bit ADC0 Accumulator formatted according to the settings in AD0SJST[2:0].	Set the least significant byte of the 16-bit ADC0 Accumulator to the value written.
Note: If Accumulator shifting is enabled, the most significant bits of the value read will be the least significant bits of the accumulator high byte. This register should not be written when the SYNC bit is set to 1.				

5.6. Programmable Window Detector

The ADC Programmable Window Detector continuously compares the ADC0 output registers to user-programmed limits, and notifies the system when a desired condition is detected. This is especially effective in an interrupt-driven system, saving code space and CPU bandwidth while delivering faster system response times. The window detector interrupt flag (AD0WINT in register ADC0CN) can also be used in polled mode. The ADC0 Greater-Than (ADC0GTH, ADC0GTL) and Less-Than (ADC0LTH, ADC0LTL) registers hold the comparison values. The window detector flag can be programmed to indicate when measured data is inside or outside of the user-programmed limits, depending on the contents of the ADC0 Less-Than and ADC0 Greater-Than registers.

Si102x/3x

SFR Definition 5.8. ADC0GTH: ADC0 Greater-Than High Byte

Bit	7	6	5	4	3	2	1	0
Name	AD0GT[15:8]							
Type	R/W							
Reset	1	1	1	1	1	1	1	1

SFR Page = 0x0; SFR Address = 0xC4

Bit	Name	Function
7:0	AD0GT[15:8]	ADC0 Greater-Than High Byte. Most Significant Byte of the 16-bit Greater-Than window compare register.

SFR Definition 5.9. ADC0GTL: ADC0 Greater-Than Low Byte

Bit	7	6	5	4	3	2	1	0
Name	AD0GT[7:0]							
Type	R/W							
Reset	1	1	1	1	1	1	1	1

SFR Page = 0x0; SFR Address = 0xC3

Bit	Name	Function
7:0	AD0GT[7:0]	ADC0 Greater-Than Low Byte. Least Significant Byte of the 16-bit Greater-Than window compare register.

Note: In 8-bit mode, this register should be set to 0x00.

SFR Definition 5.10. ADC0LTH: ADC0 Less-Than High Byte

Bit	7	6	5	4	3	2	1	0
Name	AD0LT[15:8]							
Type	R/W							
Reset	0	0	0	0	0	0	0	0

SFR Page = 0x0; SFR Address = 0xC6

Bit	Name	Function
7:0	AD0LT[15:8]	ADC0 Less-Than High Byte. Most Significant Byte of the 16-bit Less-Than window compare register.

SFR Definition 5.11. ADC0LTL: ADC0 Less-Than Low Byte

Bit	7	6	5	4	3	2	1	0
Name	AD0LT[7:0]							
Type	R/W							
Reset	0	0	0	0	0	0	0	0

SFR Page = 0x0; SFR Address = 0xC5

Bit	Name	Function
7:0	AD0LT[7:0]	ADC0 Less-Than Low Byte. Least Significant Byte of the 16-bit Less-Than window compare register.

Note: In 8-bit mode, this register should be set to 0x00.**5.6.1. Window Detector In Single-Ended Mode**

Figure 5.5 shows two example window comparisons for right-justified data, with ADC0LTH:ADC0LTL = 0x0080 (128d) and ADC0GTH:ADC0GTL = 0x0040 (64d). The input voltage can range from 0 to VREF x (1023/1024) with respect to GND, and is represented by a 10-bit unsigned integer value. In the left example, an AD0WINT interrupt will be generated if the ADC0 conversion word (ADC0H:ADC0L) is within the range defined by ADC0GTH:ADC0GTL and ADC0LTH:ADC0LTL (if $0x0040 < \text{ADC0H:ADC0L} < 0x0080$). In the right example, and AD0WINT interrupt will be generated if the ADC0 conversion word is outside of the range defined by the ADC0GT and ADC0LT registers (if $\text{ADC0H:ADC0L} < 0x0040$ or $\text{ADC0H:ADC0L} > 0x0080$). Figure 5.6 shows an example using left-justified data with the same comparison values.

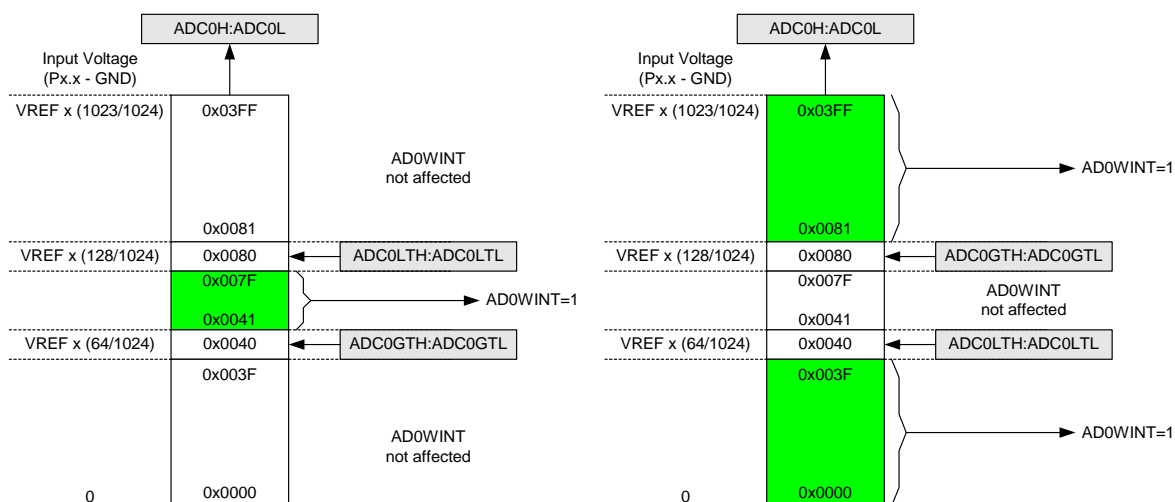

Figure 5.5. ADC Window Compare Example: Right-Justified Single-Ended Data

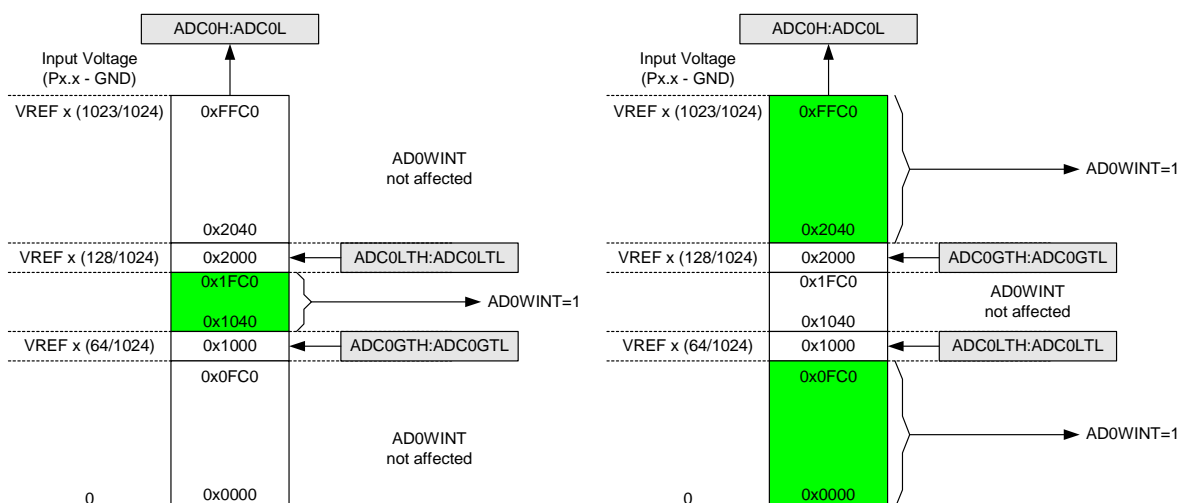

Figure 5.6. ADC Window Compare Example: Left-Justified Single-Ended Data

5.6.2. ADC0 Specifications

See “4. Electrical Characteristics” on page 50 for a detailed listing of ADC0 specifications.

5.7. ADC0 Analog Multiplexer

ADC0 on Si102x/3x has an analog multiplexer, referred to as AMUX0.

AMUX0 selects the positive inputs to the single-ended ADC0. Any of the following may be selected as the positive input: Port I/O pins, the on-chip temperature sensor, the VBAT Power Supply, Regulated Digital Supply Voltage (Output of VREG0), VDC Supply, or the positive input may be connected to GND. The ADC0 input channels are selected in the ADC0MX register described in SFR Definition 5.12.

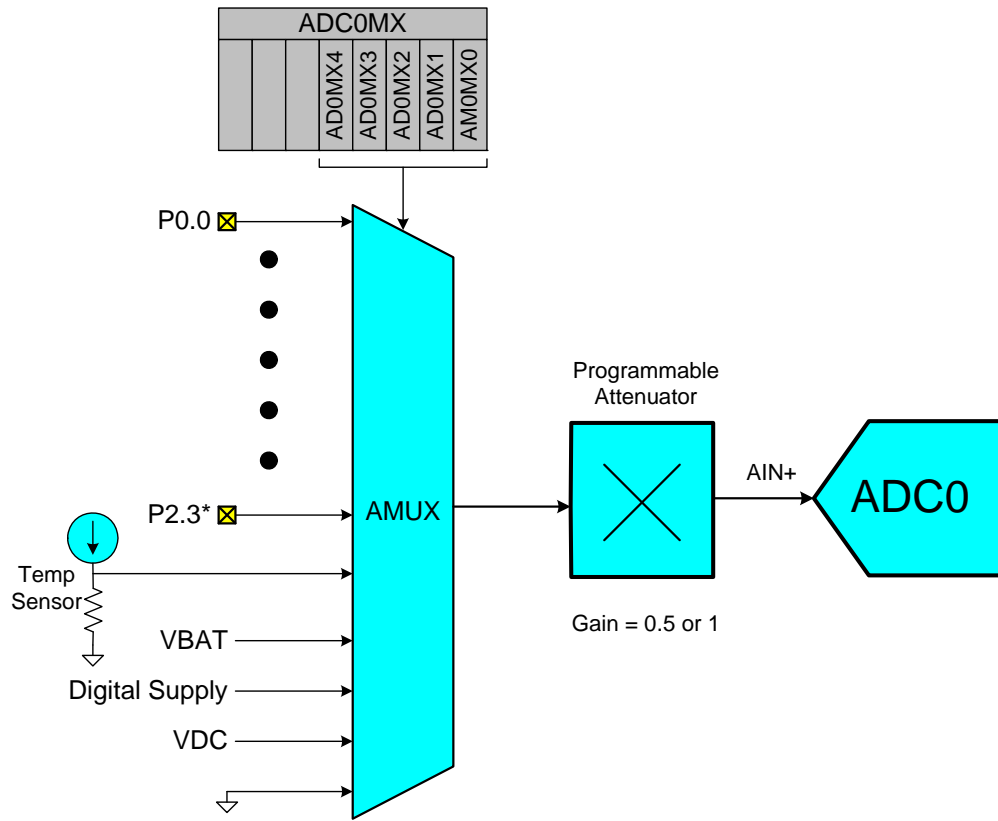

*P1.0 – P1.3 are not available as analog inputs

Figure 5.7. ADC0 Multiplexer Block Diagram

Important Note About ADC0 Input Configuration: Port pins selected as ADC0 inputs should be configured as analog inputs, and should be skipped by the Digital Crossbar. To configure a Port pin for analog input, set to 0 the corresponding bit in register PnMDIN and disable the digital driver (PnMDOUT = 0 and Port Latch = 1). To force the Crossbar to skip a Port pin, set to 1 the corresponding bit in register PnSKIP. See Section “27. Port Input/Output” on page 358 for more Port I/O configuration details.

Si102x/3x

SFR Definition 5.12. ADC0MX: ADC0 Input Channel Select

Bit	7	6	5	4	3	2	1	0
Name	AD0MX							
Type	R	R	R	R/W	R/W	R/W	R/W	R/W
Reset	0	0	0	1	1	1	1	1

SFR Page = 0x0; SFR Address = 0xBB

Bit	Name	Function																																																																
7:5	Unused	Read = 000b; Write = Don't Care.																																																																
4:0	AD0MX	<p>AMUX0 Positive Input Selection. Selects the positive input channel for ADC0.</p> <table> <tbody> <tr> <td>00000:</td> <td>P0.0</td> <td>10000:</td> <td>P2.0</td> </tr> <tr> <td>00001:</td> <td>P0.1</td> <td>10001:</td> <td>P2.1</td> </tr> <tr> <td>00010:</td> <td>P0.2</td> <td>10010:</td> <td>P2.2</td> </tr> <tr> <td>00011:</td> <td>P0.3</td> <td>10011:</td> <td>P2.3</td> </tr> <tr> <td>00100:</td> <td>P0.4</td> <td>10100:</td> <td>Reserved.</td> </tr> <tr> <td>00101:</td> <td>P0.5</td> <td>10101:</td> <td>Reserved.</td> </tr> <tr> <td>00110:</td> <td>P0.6</td> <td>10110:</td> <td>Reserved.</td> </tr> <tr> <td>00111:</td> <td>P0.7</td> <td>10111:</td> <td>Reserved.</td> </tr> <tr> <td>01000:</td> <td>Reserved</td> <td>11000:</td> <td>Reserved.</td> </tr> <tr> <td>01001:</td> <td>Reserved</td> <td>11001:</td> <td>Reserved.</td> </tr> <tr> <td>01010:</td> <td>Reserved</td> <td>11010:</td> <td>Reserved.</td> </tr> <tr> <td>01011:</td> <td>Reserved</td> <td>11011:</td> <td>Temperature Sensor</td> </tr> <tr> <td>01100:</td> <td>P1.4</td> <td>11100:</td> <td>VBAT Supply Voltage (1.8–3.6 V)</td> </tr> <tr> <td>01101:</td> <td>P1.5</td> <td>11101:</td> <td>Digital Supply Voltage (VREG0 Output, 1.7 V Typical)</td> </tr> <tr> <td>01110:</td> <td>P1.6</td> <td>11110:</td> <td>VBAT Supply Voltage (1.8–3.6 V)</td> </tr> <tr> <td>01111:</td> <td>P1.7</td> <td>11111:</td> <td>Ground</td> </tr> </tbody> </table>	00000:	P0.0	10000:	P2.0	00001:	P0.1	10001:	P2.1	00010:	P0.2	10010:	P2.2	00011:	P0.3	10011:	P2.3	00100:	P0.4	10100:	Reserved.	00101:	P0.5	10101:	Reserved.	00110:	P0.6	10110:	Reserved.	00111:	P0.7	10111:	Reserved.	01000:	Reserved	11000:	Reserved.	01001:	Reserved	11001:	Reserved.	01010:	Reserved	11010:	Reserved.	01011:	Reserved	11011:	Temperature Sensor	01100:	P1.4	11100:	VBAT Supply Voltage (1.8–3.6 V)	01101:	P1.5	11101:	Digital Supply Voltage (VREG0 Output, 1.7 V Typical)	01110:	P1.6	11110:	VBAT Supply Voltage (1.8–3.6 V)	01111:	P1.7	11111:	Ground
00000:	P0.0	10000:	P2.0																																																															
00001:	P0.1	10001:	P2.1																																																															
00010:	P0.2	10010:	P2.2																																																															
00011:	P0.3	10011:	P2.3																																																															
00100:	P0.4	10100:	Reserved.																																																															
00101:	P0.5	10101:	Reserved.																																																															
00110:	P0.6	10110:	Reserved.																																																															
00111:	P0.7	10111:	Reserved.																																																															
01000:	Reserved	11000:	Reserved.																																																															
01001:	Reserved	11001:	Reserved.																																																															
01010:	Reserved	11010:	Reserved.																																																															
01011:	Reserved	11011:	Temperature Sensor																																																															
01100:	P1.4	11100:	VBAT Supply Voltage (1.8–3.6 V)																																																															
01101:	P1.5	11101:	Digital Supply Voltage (VREG0 Output, 1.7 V Typical)																																																															
01110:	P1.6	11110:	VBAT Supply Voltage (1.8–3.6 V)																																																															
01111:	P1.7	11111:	Ground																																																															

5.8. Temperature Sensor

An on-chip temperature sensor is included on the Si102x/3x which can be directly accessed via the ADC multiplexer in single-ended configuration. To use the ADC to measure the temperature sensor, the ADC mux channel should select the temperature sensor. The temperature sensor transfer function is shown in Figure 5.8. The output voltage (V_{TEMP}) is the positive ADC input when the ADC multiplexer is set correctly. The TEMPE bit in register REF0CN enables/disables the temperature sensor, as described in SFR Definition 5.15. REF0CN: Voltage Reference Control. While disabled, the temperature sensor defaults to a high impedance state and any ADC measurements performed on the sensor will result in meaningless data. Refer to Table 4.12 for the slope and offset parameters of the temperature sensor.

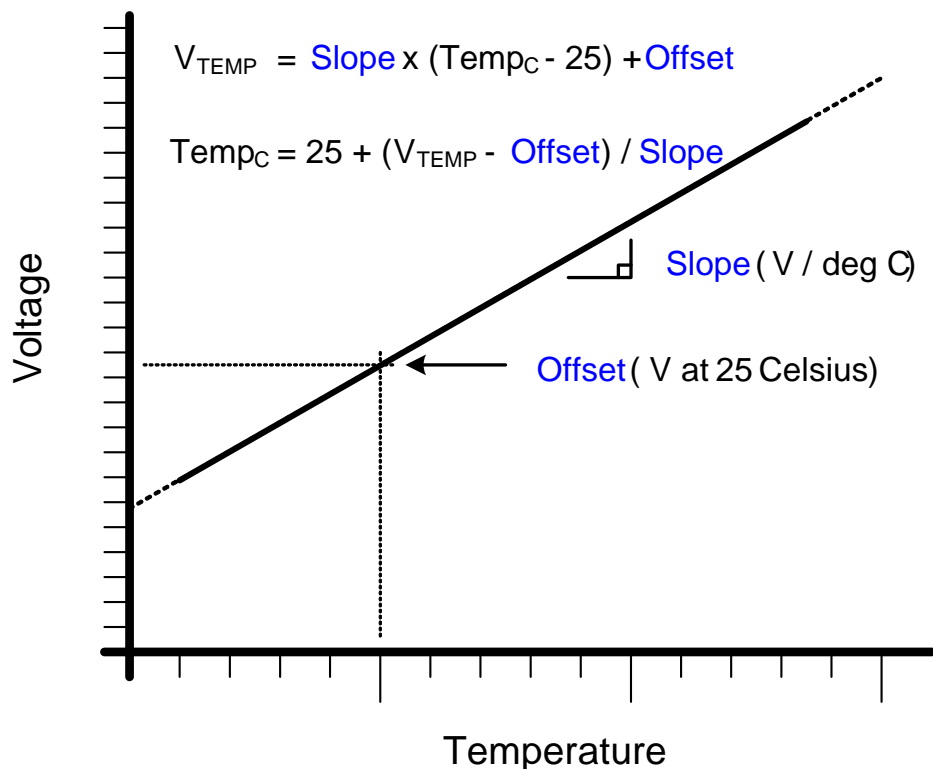

Figure 5.8. Temperature Sensor Transfer Function

5.8.1. Calibration

The uncalibrated temperature sensor output is extremely linear and suitable for relative temperature measurements (see Table 4.13 for linearity specifications). For absolute temperature measurements, offset and/or gain calibration is recommended. Typically a 1-point (offset) calibration includes the following steps:

1. Control/measure the ambient temperature (this temperature must be known).
2. Power the device, and delay for a few seconds to allow for self-heating.
3. Perform an ADC conversion with the temperature sensor selected as the positive input and GND selected as the negative input.
4. Calculate the offset characteristics, and store this value in non-volatile memory for use with subsequent temperature sensor measurements.

Si102x/3x

Figure 5.9 shows the typical temperature sensor error assuming a 1-point calibration at 25 °C. **Parameters that affect ADC measurement, in particular the voltage reference value, will also affect temperature measurement.**

A single-point offset measurement of the temperature sensor is performed on each device during production test. The measurement is performed at 25 °C ±5 °C, using the ADC with the internal high speed reference buffer selected as the Voltage Reference. The direct ADC result of the measurement is stored in the SFR registers TOFFH and TOFFL, shown in SFR Definition 5.13 and SFR Definition 5.14.

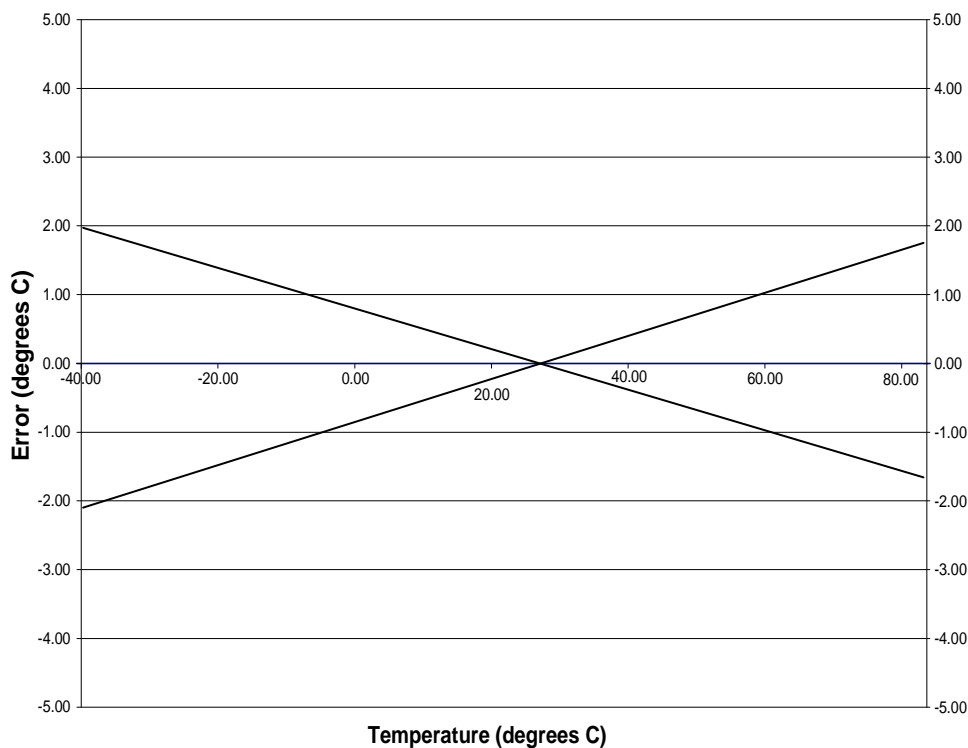

Figure 5.9. Temperature Sensor Error with 1-Point Calibration ($V_{REF} = 1.68\text{ V}$)

SFR Definition 5.13. TOFFH: Temperature Sensor Offset High Byte

Bit	7	6	5	4	3	2	1	0
Name	TOFF[9:2]							
Type	R	R	R	R	R	R	R	R
Reset	Varies	Varies	Varies	Varies	Varies	Varies	Varies	Varies

SFR Page = 0xF; SFR Address = 0xBE

Bit	Name	Function
7:0	TOFF[9:2]	Temperature Sensor Offset High Bits. Most Significant Bits of the 10-bit temperature sensor offset measurement.

SFR Definition 5.14. TOFFL: Temperature Sensor Offset Low Byte

Bit	7	6	5	4	3	2	1	0
Name	TOFF[1:0]							
Type	R	R						
Reset	Varies	Varies	0	0	0	0	0	0

SFR Page = 0xF; SFR Address = 0xBD

Bit	Name	Function
7:6	TOFF[1:0]	Temperature Sensor Offset Low Bits. Least Significant Bits of the 10-bit temperature sensor offset measurement.
5:0	Unused	Read = 0; Write = Don't Care.

5.9. Voltage and Ground Reference Options

The voltage reference MUX is configurable to use an externally connected voltage reference, the internal voltage reference, or one of two power supply voltages (see Figure 5.10). The ground reference MUX allows the ground reference for ADC0 to be selected between the ground pin (GND) or a port pin dedicated to analog ground (P0.1/AGND).

The voltage and ground reference options are configured using the REF0CN SFR described on SFR Definition 5.15. REF0CN: Voltage Reference Control. Electrical specifications are can be found in the Electrical Specifications Chapter.

Important Note About the V_{REF} and AGND Inputs: Port pins are used as the external V_{REF} and AGND inputs. When using an external voltage reference or the internal precision reference, P0.0/VREF should be configured as an analog input and skipped by the Digital Crossbar. When using AGND as the ground reference to ADC0, P0.1/AGND should be configured as an analog input and skipped by the Digital Crossbar. Refer to Section “27. Port Input/Output” on page 358 for complete Port I/O configuration details. The external reference voltage must be within the range $0 \leq V_{REF} \leq VDD$ and the external ground reference must be at the same DC voltage potential as GND.

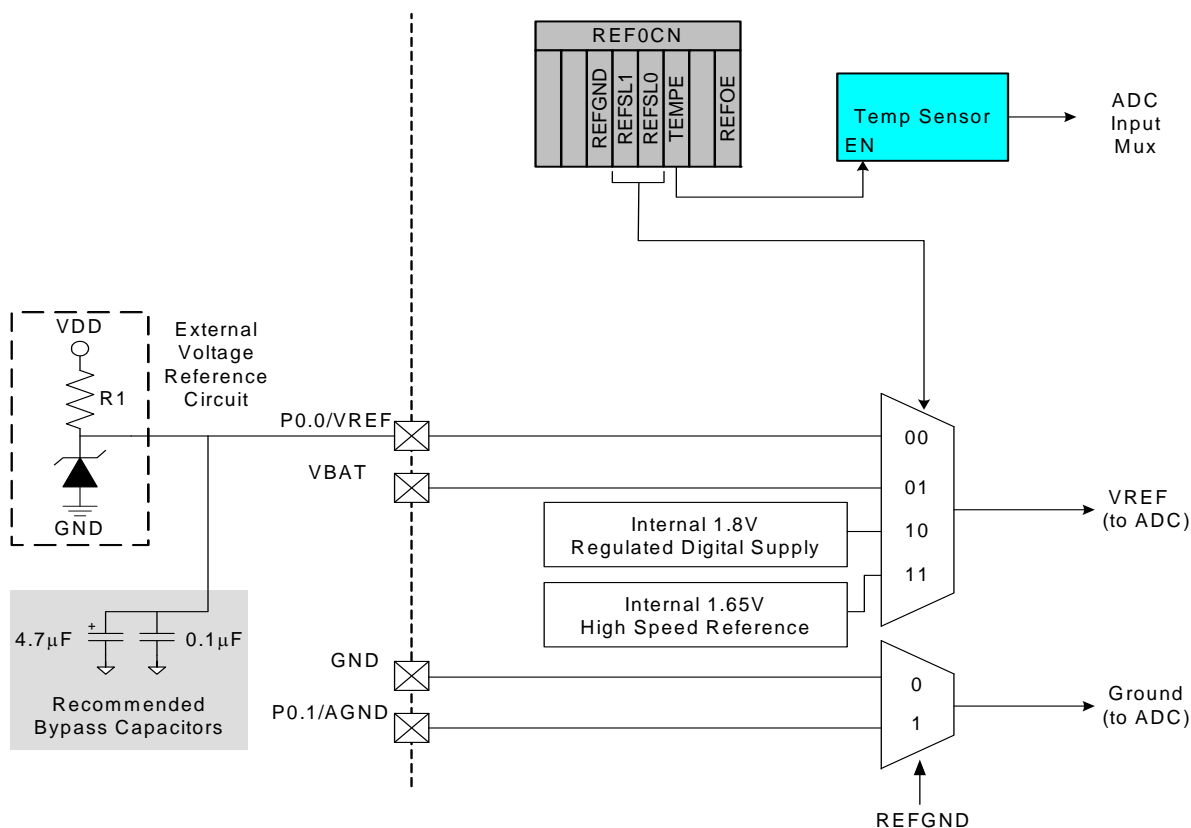

Figure 5.10. Voltage Reference Functional Block Diagram

5.10. External Voltage Reference

To use an external voltage reference, REFSL[1:0] should be set to 00. Bypass capacitors should be added as recommended by the manufacturer of the external voltage reference. If the manufacturer does not provide recommendations, a 4.7uF in parallel with a 0.1uF capacitor is recommended.

5.11. Internal Voltage Reference

For applications requiring the maximum number of port I/O pins, or very short VREF turn-on time, the 1.65 V high-speed reference will be the best internal reference option to choose. The high speed internal reference is selected by setting REFSL[1:0] to 11. When selected, the high speed internal reference will be automatically enabled/disabled on an as-needed basis by ADC0.

For applications with a non-varying power supply voltage, using the power supply as the voltage reference can provide ADC0 with added dynamic range at the cost of reduced power supply noise rejection. To use the 1.8 to 3.6 V power supply voltage (V_{DD}) or the 1.8 V regulated digital supply voltage as the reference source, REFSL[1:0] should be set to 01 or 10, respectively.

5.12. Analog Ground Reference

To prevent ground noise generated by switching digital logic from affecting sensitive analog measurements, a separate analog ground reference option is available. When enabled, the ground reference for ADC0 during both the tracking/sampling and the conversion periods is taken from the P0.1/AGND pin. Any external sensors sampled by ADC0 should be referenced to the P0.1/AGND pin. This pin should be connected to the ground terminal of any external sensors sampled by ADC0. If an external voltage reference is used, the P0.1/AGND pin should be connected to the ground of the external reference and its associated decoupling capacitor. The separate analog ground reference option is enabled by setting REFGND to 1. Note that when sampling the internal temperature sensor, the internal chip ground is always used for the sampling operation, regardless of the setting of the REFGND bit. Similarly, whenever the internal 1.65 V high-speed reference is selected, the internal chip ground is always used during the conversion period, regardless of the setting of the REFGND bit.

5.13. Temperature Sensor Enable

The TEMPE bit in register REF0CN enables/disables the temperature sensor. While disabled, the temperature sensor defaults to a high impedance state and any ADC0 measurements performed on the sensor result in meaningless data. See Section “5.8. Temperature Sensor” on page 97 for details on temperature sensor characteristics when it is enabled.

SFR Definition 5.15. REF0CN: Voltage Reference Control

Bit	7	6	5	4	3	2	1	0
Name			REFGND	REFSL		TEMPE		
Type	R	R	R/W	R/W	R/W	R/W	R	R
Reset	0	0	0	1	1	0	0	0

SFR Page = 0x0; SFR Address = 0xD1

Bit	Name	Function
7:6	Unused	Read = 00b; Write = Don't Care.
5	REFGND	Analog Ground Reference. Selects the ADC0 ground reference. 0: The ADC0 ground reference is the GND pin. 1: The ADC0 ground reference is the P0.1/AGND pin.
4:3	REFSL	Voltage Reference Select. Selects the ADC0 voltage reference. 00: The ADC0 voltage reference is the P0.0/VREF pin. 01: The ADC0 voltage reference is the VDD pin. 10: The ADC0 voltage reference is the internal 1.8 V digital supply voltage. 11: The ADC0 voltage reference is the internal 1.65 V high speed voltage reference.
2	TEMPE	Temperature Sensor Enable. Enables/Disables the internal temperature sensor. 0: Temperature Sensor Disabled. 1: Temperature Sensor Enabled.
1:0	Unused	Read = 00b; Write = Don't Care.

5.14. Voltage Reference Electrical Specifications

See Table 4.14 on page 64 for detailed Voltage Reference Electrical Specifications.

6. Comparators

Si102x/3x devices include two on-chip programmable voltage comparators: Comparator 0 (CPT0) is shown in Figure 6.1; Comparator 1 (CPT1) is shown in Figure 6.2. The two comparators operate identically, but may differ in their ability to be used as reset or wake-up sources. See the Reset Sources chapter and the Power Management chapter for details on reset sources and low power mode wake-up sources, respectively.

The comparator offers programmable response time and hysteresis, an analog input multiplexer, and two outputs that are optionally available at the port pins: a synchronous output (CP0, CP1), or an asynchronous output (CP0A, CP1A). The asynchronous CP0A signal is available even when the system clock is not active. This allows the comparator to operate and generate an output when the device is in some low power modes.

6.1. Comparator Inputs

Each comparator performs an analog comparison of the voltage levels at its positive (CP0+ or CP1+) and negative (CP0- or CP1-) input. Both comparators support multiple port pin inputs multiplexed to their positive and negative comparator inputs using analog input multiplexers. The analog input multiplexers are completely under software control and configured using SFR registers. See “7.3. Comparator0 and Comparator1 Analog Multiplexers” on page 112 for details on how to select and configure comparator inputs.

Important Note About Comparator Inputs: The port pins selected as comparator inputs should be configured as analog inputs and skipped by the crossbar. See “27. Port Input/Output” on page 358 for more details on how to configure port I/O pins as analog inputs. The comparator may also be used to compare the logic level of digital signals, however, port I/O pins configured as digital inputs must be driven to a valid logic state (HIGH or LOW) to avoid increased power consumption.

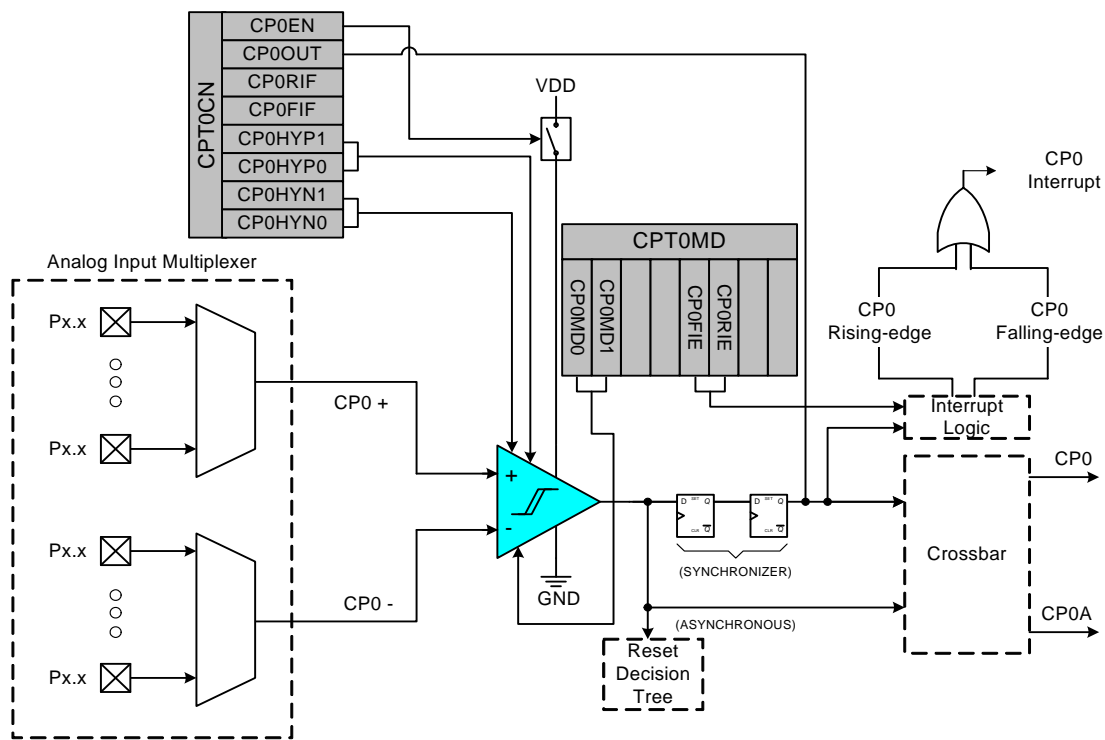

Figure 6.1. Comparator 0 Functional Block Diagram

6.2. Comparator Outputs

When a comparator is enabled, its output is a logic 1 if the voltage at the positive input is higher than the voltage at the negative input. When disabled, the comparator output is a logic 0. The comparator output is synchronized with the system clock as shown in Figure 6.2. The synchronous output (CP0, CP1) can be polled in software (CPnOUT bit), used as an interrupt source, or routed to a port pin through the crossbar.

The asynchronous comparator output (CP0A, CP1A) is used by the low power mode wakeup logic and reset decision logic. See "19. Power Management" on page 264 and "22. Reset Sources" on page 285 for more details on how the asynchronous comparator outputs are used to make wake-up and reset decisions. The asynchronous comparator output can also be routed directly to a port pin through the crossbar, and is available for use outside the device even if the system clock is stopped.

When using a comparator as an interrupt source, comparator interrupts can be generated on rising-edge and/or falling-edge comparator output transitions. Two independent interrupt flags (CPnRIF and CPnFIF) allow software to determine which edge caused the comparator interrupt. The comparator rising-edge and falling-edge interrupt flags are set by hardware when a corresponding edge is detected regardless of the interrupt enable state. Once set, these bits remain set until cleared by software.

The rising-edge and falling-edge interrupts can be individually enabled using the CPnRIE and CPnFIE interrupt enable bits in the CPTnMD register. In order for the CPnRIF and/or CPnFIF interrupt flags to generate an interrupt request to the CPU, the comparator must be enabled as an interrupt source and global interrupts must be enabled. See "17. Interrupt Handler" on page 238 for additional information.

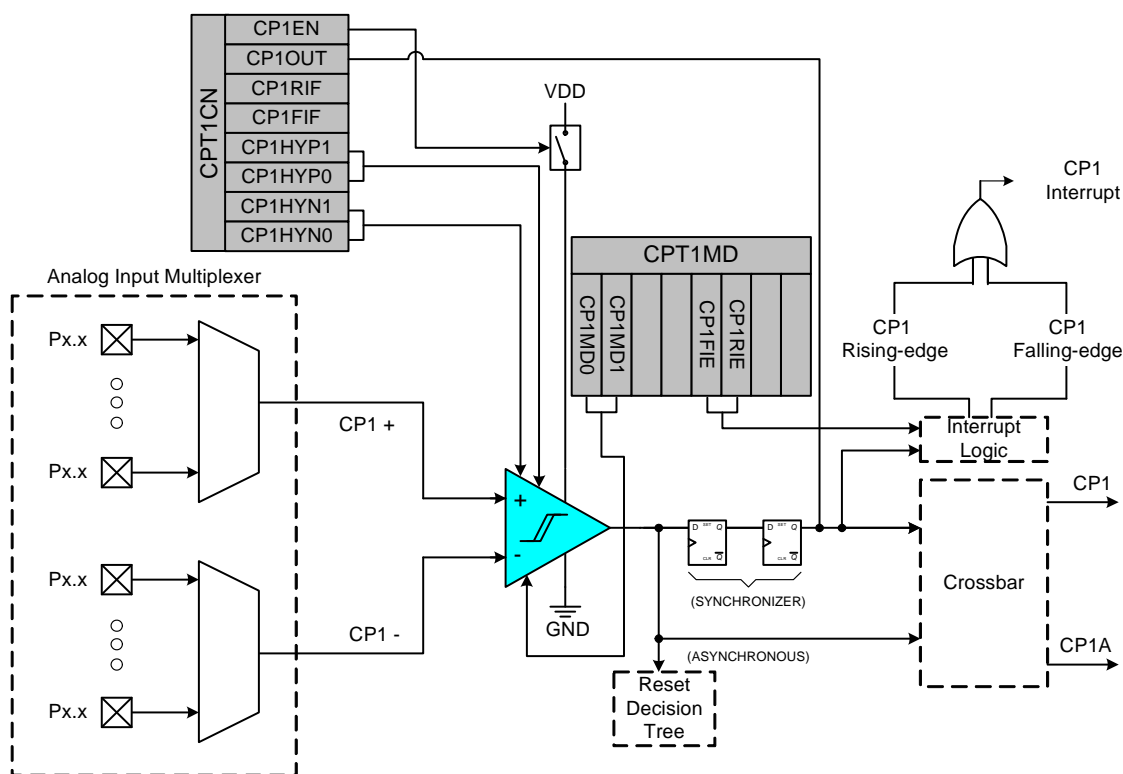

Figure 6.2. Comparator 1 Functional Block Diagram

6.3. Comparator Response Time

Comparator response time may be configured in software via the CPTnMD registers described on "SFR Definition 6.2. CPT0MD: Comparator 0 Mode Selection" on page 107 and "SFR Definition 6.4. CPT1MD: Comparator 1 Mode Selection" on page 109. Four response time settings are available: Mode 0 (Fastest Response Time), Mode 1, Mode 2, and Mode 3 (Lowest Power). Selecting a longer response time reduces the comparator active supply current. The comparators also have low power shutdown state, which is entered any time the comparator is disabled. Comparator rising edge and falling edge response times are typically not equal. See Table 4.16 on page 66 for complete comparator timing and supply current specifications.

6.4. Comparator Hysteresis

The comparators feature software-programmable hysteresis that can be used to stabilize the comparator output while a transition is occurring on the input. Using the CPTnCN registers, the user can program both the amount of hysteresis voltage (referred to the input voltage) and the positive and negative-going symmetry of this hysteresis around the threshold voltage (i.e., the comparator negative input).

Figure 6.3 shows that when positive hysteresis is enabled, the comparator output does not transition from logic 0 to logic 1 until the comparator positive input voltage has exceeded the threshold voltage by an amount equal to the programmed hysteresis. It also shows that when negative hysteresis is enabled, the comparator output does not transition from logic 1 to logic 0 until the comparator positive input voltage has fallen below the threshold voltage by an amount equal to the programmed hysteresis.

The amount of positive hysteresis is determined by the settings of the CPnHYP bits in the CPTnCN register and the amount of negative hysteresis voltage is determined by the settings of the CPnHYN bits in the same register. Settings of 20 mV, 10 mV, 5 mV, or 0 mV can be programmed for both positive and negative hysteresis. See "Table 4.16. Comparator Electrical Characteristics" on page 66 for complete comparator hysteresis specifications.

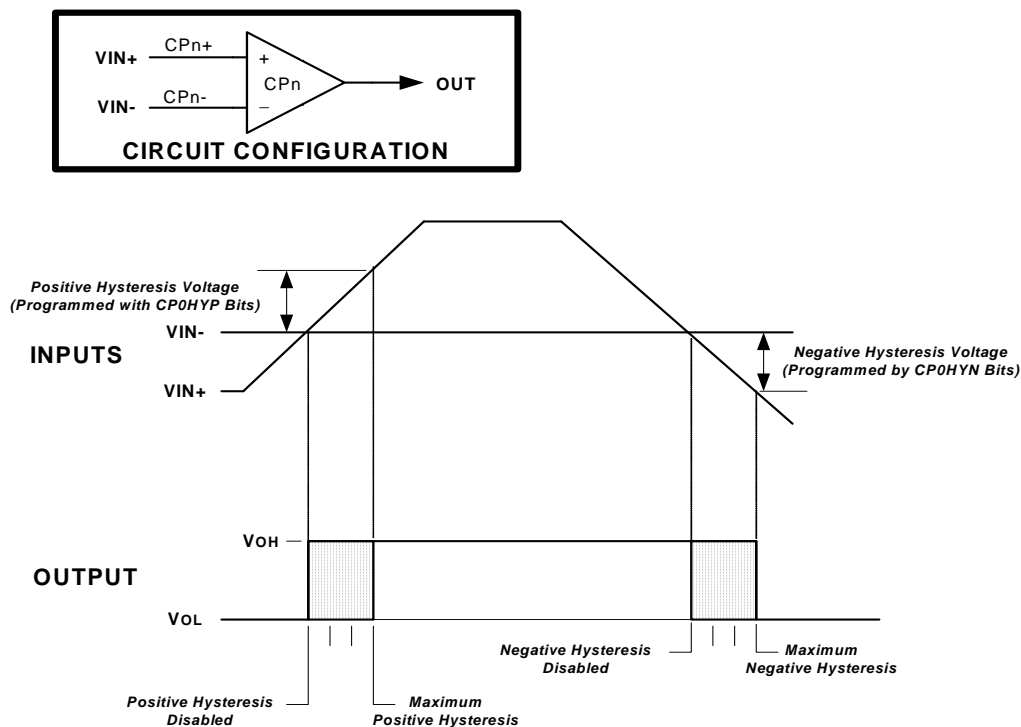

Figure 6.3. Comparator Hysteresis Plot

Si102x/3x

6.5. Comparator Register Descriptions

The SFRs used to enable and configure the comparators are described in the following register descriptions. A comparator must be enabled by setting the CPnEN bit to logic 1 before it can be used. From an enabled state, a comparator can be disabled and placed in a low power state by clearing the CPnEN bit to logic 0.

Important Note About Comparator Settings: False rising and falling edges can be detected by the comparator while powering on or if changes are made to the hysteresis or response time control bits. Therefore, it is recommended that the rising-edge and falling-edge flags be explicitly cleared to logic 0 a short time after the comparator is enabled or its mode bits have been changed. The comparator power up time is specified in Table 4.16, “Comparator Electrical Characteristics,” on page 66.

SFR Definition 6.1. CPT0CN: Comparator 0 Control

Bit	7	6	5	4	3	2	1	0
Name	CP0EN	CP0OUT	CP0RIF	CP0FIF	CP0HYP[1:0]		CP0HYN[1:0]	
Type	R/W	R	R/W	R/W	R/W		R/W	
Reset	0	0	0	0	0	0	0	0

SFR Page= 0x0; SFR Address = 0x9B

Bit	Name	Function
7	CP0EN	Comparator0 Enable Bit. 0: Comparator0 Disabled. 1: Comparator0 Enabled.
6	CP0OUT	Comparator0 Output State Flag. 0: Voltage on CP0+ < CP0-. 1: Voltage on CP0+ > CP0-.
5	CP0RIF	Comparator0 Rising-Edge Flag. Must be cleared by software. 0: No Comparator0 Rising Edge has occurred since this flag was last cleared. 1: Comparator0 Rising Edge has occurred.
4	CP0FIF	Comparator0 Falling-Edge Flag. Must be cleared by software. 0: No Comparator0 Falling-Edge has occurred since this flag was last cleared. 1: Comparator0 Falling-Edge has occurred.
3-2	CP0HYP[1:0]	Comparator0 Positive Hysteresis Control Bits. 00: Positive Hysteresis Disabled. 01: Positive Hysteresis = 5 mV. 10: Positive Hysteresis = 10 mV. 11: Positive Hysteresis = 20 mV.
1-0	CP0HYN[1:0]	Comparator0 Negative Hysteresis Control Bits. 00: Negative Hysteresis Disabled. 01: Negative Hysteresis = 5 mV. 10: Negative Hysteresis = 10 mV. 11: Negative Hysteresis = 20 mV.

SFR Definition 6.2. CPT0MD: Comparator 0 Mode Selection

Bit	7	6	5	4	3	2	1	0
Name			CP0RIE	CP0FIE			CP0MD[1:0]	
Type	R/W	R	R/W	R/W	R	R	R/W	
Reset	1	0	0	0	0	0	1	0

SFR Page = 0x0; SFR Address = 0x9D

Bit	Name	Function
7	Reserved	Read = 1b, Must Write 1b.
6	Unused	Read = 0b, Write = don't care.
5	CP0RIE	Comparator0 Rising-Edge Interrupt Enable. 0: Comparator0 Rising-edge interrupt disabled. 1: Comparator0 Rising-edge interrupt enabled.
4	CP0FIE	Comparator0 Falling-Edge Interrupt Enable. 0: Comparator0 Falling-edge interrupt disabled. 1: Comparator0 Falling-edge interrupt enabled.
3:2	Unused	Read = 00b, Write = don't care.
1:0	CP0MD[1:0]	Comparator0 Mode Select These bits affect the response time and power consumption for Comparator0. 00: Mode 0 (Fastest Response Time, Highest Power Consumption) 01: Mode 1 10: Mode 2 11: Mode 3 (Slowest Response Time, Lowest Power Consumption)

Si102x/3x

SFR Definition 6.3. CPT1CN: Comparator 1 Control

Bit	7	6	5	4	3	2	1	0
Name	CP1EN	CP1OUT	CP1RIF	CP1FIF	CP1HYP[1:0]		CP1HYN[1:0]	
Type	R/W	R	R/W	R/W	R/W		R/W	
Reset	0	0	0	0	0	0	0	0

SFR Page= 0x0; SFR Address = 0x9A

Bit	Name	Function
7	CP1EN	Comparator1 Enable Bit. 0: Comparator1 Disabled. 1: Comparator1 Enabled.
6	CP1OUT	Comparator1 Output State Flag. 0: Voltage on CP1+ < CP1-. 1: Voltage on CP1+ > CP1-.
5	CP1RIF	Comparator1 Rising-Edge Flag. Must be cleared by software. 0: No Comparator1 Rising Edge has occurred since this flag was last cleared. 1: Comparator1 Rising Edge has occurred.
4	CP1FIF	Comparator1 Falling-Edge Flag. Must be cleared by software. 0: No Comparator1 Falling-Edge has occurred since this flag was last cleared. 1: Comparator1 Falling-Edge has occurred.
3:2	CP1HYP[1:0]	Comparator1 Positive Hysteresis Control Bits. 00: Positive Hysteresis Disabled. 01: Positive Hysteresis = 5 mV. 10: Positive Hysteresis = 10 mV. 11: Positive Hysteresis = 20 mV.
1:0	CP1HYN[1:0]	Comparator1 Negative Hysteresis Control Bits. 00: Negative Hysteresis Disabled. 01: Negative Hysteresis = 5 mV. 10: Negative Hysteresis = 10 mV. 11: Negative Hysteresis = 20 mV.

SFR Definition 6.4. CPT1MD: Comparator 1 Mode Selection

Bit	7	6	5	4	3	2	1	0
Name			CP1RIE	CP1FIE			CP1MD[1:0]	
Type	R/W	R	R/W	R/W	R	R	R/W	
Reset	1	0	0	0	0	0	1	0

SFR Page = 0x0; SFR Address = 0x9C

Bit	Name	Function
7	Reserved	Read = 1b, Must Write 1b.
6	Unused	Unused. Read = 00b, Write = don't care.
5	CP1RIE	Comparator1 Rising-Edge Interrupt Enable. 0: Comparator1 Rising-edge interrupt disabled. 1: Comparator1 Rising-edge interrupt enabled.
4	CP1FIE	Comparator1 Falling-Edge Interrupt Enable. 0: Comparator1 Falling-edge interrupt disabled. 1: Comparator1 Falling-edge interrupt enabled.
3:2	Unused	Read = 00b, Write = don't care.
1:0	CP1MD[1:0]	Comparator1 Mode Select These bits affect the response time and power consumption for Comparator1. 00: Mode 0 (Fastest Response Time, Highest Power Consumption) 01: Mode 1 10: Mode 2 11: Mode 3 (Slowest Response Time, Lowest Power Consumption)

Si102x/3x

7. Programmable Current Reference (IREF0)

Si102x/3x devices include an on-chip programmable current reference (source or sink) with two output current settings: Low Power Mode and High Current Mode. The maximum current output in Low Power Mode is 63 μA (1 μA steps) and the maximum current output in High Current Mode is 504 μA (8 μA steps).

The current source/sink is controlled through the IREF0CN special function register. It is enabled by setting the desired output current to a non-zero value. It is disabled by writing 0x00 to IREF0CN. The port I/O pin associated with ISRC0 should be configured as an analog input and skipped in the Crossbar. See "Port Input/Output" on page 358 for more details.

SFR Definition 7.1. IREF0CN: Current Reference Control

Bit	7	6	5	4	3	2	1	0
Name	SINK	MODE	IREF0DAT					
Type	R/W	R/W	R/W					
Reset	0	0	0	0	0	0	0	0

SFR Page = 0x0; SFR Address = 0xB9

Bit	Name	Function
7	SINK	IREF0 Current Sink Enable. Selects if IREF0 is a current source or a current sink. 0: IREF0 is a current source. 1: IREF0 is a current sink.
6	MDSEL	IREF0 Output Mode Select. Selects Low Power or High Current Mode. 0: Low Power Mode is selected (step size = 1 μA). 1: High Current Mode is selected (step size = 8 μA).
5:0	IREF0DAT[5:0]	IREF0 Data Word. Specifies the number of steps required to achieve the desired output current. Output current = direction x step size x IREF0DAT. IREF0 is in a low power state when IREF0DAT is set to 0x00.

7.1. PWM Enhanced Mode

The precision of the current reference can be increased by fine tuning the IREF0 output using a PWM signal generated by the PCA. This mode allows the IREF0DAT bits to perform a coarse adjustment on the IREF0 output. Any available PCA channel can perform a fine adjustment on the IREF0 output. When enabled (PWMEN = 1), the CEX signal selected using the PWMSS bit field is internally routed to IREF0 to control the on time of a current source having the weight of 2 LSBs. With the two least significant bits of IREF0DAT set to 00b, applying a 100% duty cycle on the CEX signal will be equivalent to setting the two LSBs of IREF0DAT to 10b. PWM enhanced mode is enabled and setup using the IREF0CF register.

SFR Definition 7.2. IREF0CF: Current Reference Configuration

Bit	7	6	5	4	3	2	1	0
Name	PWMEN					PWMSS[2:0]		
Type	R/W	R/W	R/W	R/W	R/W	R/W		
Reset	0	0	0	0	0	0	0	0

SFR Page = 0xF; SFR Address = 0xB9

Bit	Name	Function
7	PWMEN	PWM Enhanced Mode Enable. Enables the PWM Enhanced Mode. 0: PWM Enhanced Mode disabled. 1: PWM Enhanced Mode enabled.
6:3	Unused	Read = 0000b, Write = don't care.
2:0	PWMSS[2:0]	PWM Source Select. Selects the PCA channel to use for the fine-tuning control signal. 000: CEX0 selected as fine-tuning control signal. 001: CEX1 selected as fine-tuning control signal. 010: CEX2 selected as fine-tuning control signal. 011: CEX3 selected as fine-tuning control signal. 100: CEX4 selected as fine-tuning control signal. 101: CEX5 selected as fine tuning control signal. All Other Values: Reserved.

7.2. IREF0 Specifications

See Table 4.15 on page 65 for a detailed listing of IREF0 specifications.

7.3. Comparator0 and Comparator1 Analog Multiplexers

Comparator0 and Comparator1 on Si102x/3x devices have analog input multiplexers to connect port I/O pins and internal signals the comparator inputs; CP0+/CP0- are the positive and negative input multiplexers for Comparator0 and CP1+/CP1- are the positive and negative input multiplexers for Comparator1.

The comparator input multiplexers directly support capacitive sensors. When the Compare input is selected on the positive or negative multiplexer, any Port I/O pin connected to the other multiplexer can be directly connected to a capacitive sensor with no additional external components. The Compare signal provides the appropriate reference level for detecting when the capacitive sensor has charged or discharged through the on-chip Rsense resistor. The Comparator0 output can be routed to Timer2 for capturing the capacitor's charge and discharge time. See Section "33. Timers" on page 491 for details.

Any of the following may be selected as comparator inputs: port I/O pins, capacitive touch sense compare, VDD/DC+ supply voltage, regulated digital supply voltage (output of VREG0), the VBAT supply voltage or ground. The comparator's supply voltage divided by 2 is also available as an input; the resistors used to divide the voltage only draw current when this setting is selected. The comparator input multiplexers are configured using the CPT0MX and CPT1MX registers described in SFR Definition 7.3 and SFR Definition 7.4.

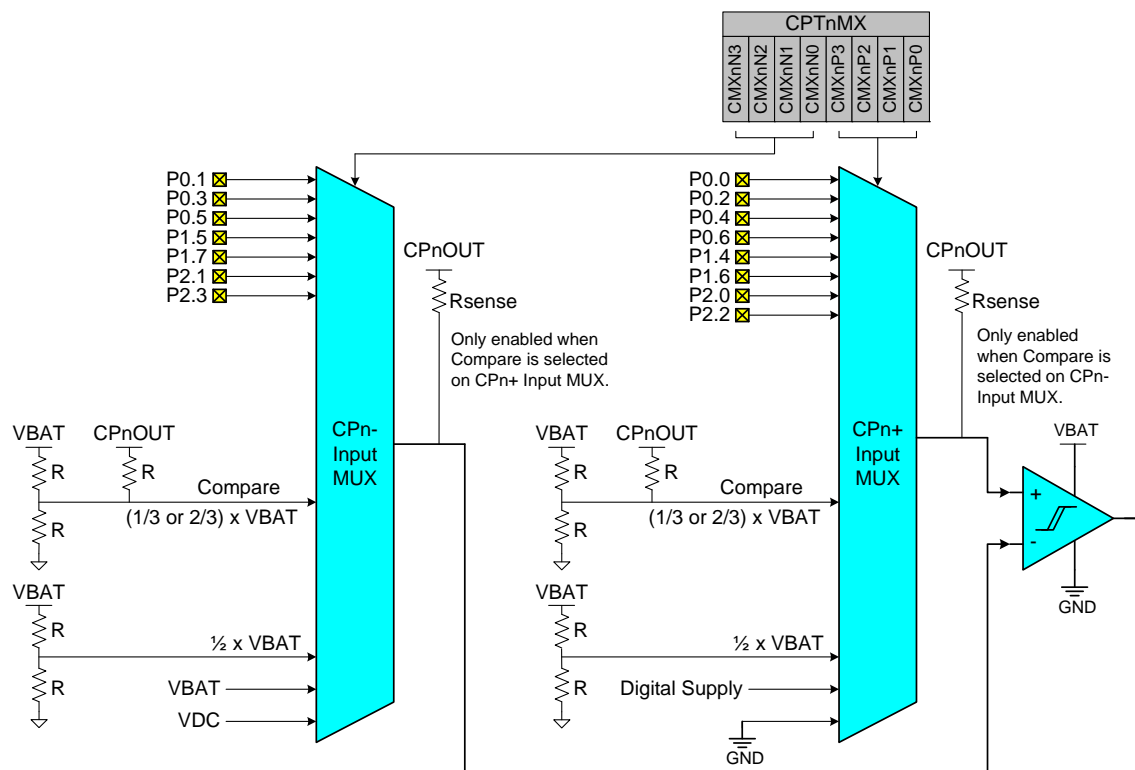

Figure 7.1. CPn Multiplexer Block Diagram

Important Note About Comparator Input Configuration: Port pins selected as comparator inputs should be configured as analog inputs, and should be skipped by the digital crossbar. To configure a port pin for analog input, set to 0 the corresponding bit in register PnMDIN and disable the digital driver (PnMDOUT = 0 and Port Latch = 1). To force the crossbar to skip a port pin, set to 1 the corresponding bit in register PnSKIP. See Section "27. Port Input/Output" on page 358 for more port I/O configuration details.

SFR Definition 7.3. CPT0MX: Comparator0 Input Channel Select

Bit	7	6	5	4	3	2	1	0
Name	CMX0N[3:0]				CMX0P[3:0]			
Type	R/W	R/W	R/W	R/W	R/W	R/W	R/W	R/W
Reset	1	1	1	1	1	1	1	1

SFR Page = 0x0; SFR Address = 0x9F

Bit	Name	Function																																
7:4	CMX0N	<p>Comparator0 Negative Input Selection. Selects the negative input channel for Comparator0.</p> <table> <tbody> <tr> <td>0000:</td> <td>P0.1</td> <td>1000:</td> <td>P2.1</td> </tr> <tr> <td>0001:</td> <td>P0.3</td> <td>1001:</td> <td>P2.3</td> </tr> <tr> <td>0010:</td> <td>P0.5</td> <td>1010:</td> <td>Reserved</td> </tr> <tr> <td>0011:</td> <td>Reserved</td> <td>1011:</td> <td>Reserved</td> </tr> <tr> <td>0100:</td> <td>Reserved</td> <td>1100:</td> <td>Compare</td> </tr> <tr> <td>0101:</td> <td>Reserved</td> <td>1101:</td> <td>VBAT divided by 2</td> </tr> <tr> <td>0110:</td> <td>P1.5</td> <td>1110:</td> <td>Digital Supply Voltage</td> </tr> <tr> <td>0111:</td> <td>P1.7</td> <td>1111:</td> <td>Ground</td> </tr> </tbody> </table>	0000:	P0.1	1000:	P2.1	0001:	P0.3	1001:	P2.3	0010:	P0.5	1010:	Reserved	0011:	Reserved	1011:	Reserved	0100:	Reserved	1100:	Compare	0101:	Reserved	1101:	VBAT divided by 2	0110:	P1.5	1110:	Digital Supply Voltage	0111:	P1.7	1111:	Ground
0000:	P0.1	1000:	P2.1																															
0001:	P0.3	1001:	P2.3																															
0010:	P0.5	1010:	Reserved																															
0011:	Reserved	1011:	Reserved																															
0100:	Reserved	1100:	Compare																															
0101:	Reserved	1101:	VBAT divided by 2																															
0110:	P1.5	1110:	Digital Supply Voltage																															
0111:	P1.7	1111:	Ground																															
3:0	CMX0P	<p>Comparator0 Positive Input Selection. Selects the positive input channel for Comparator0.</p> <table> <tbody> <tr> <td>0000:</td> <td>P0.0</td> <td>1000:</td> <td>P2.0</td> </tr> <tr> <td>0001:</td> <td>P0.2</td> <td>1001:</td> <td>P2.2</td> </tr> <tr> <td>0010:</td> <td>P0.4</td> <td>1010:</td> <td>Reserved</td> </tr> <tr> <td>0011:</td> <td>P0.6</td> <td>1011:</td> <td>Reserved</td> </tr> <tr> <td>0100:</td> <td>Reserved</td> <td>1100:</td> <td>Compare</td> </tr> <tr> <td>0101:</td> <td>Reserved</td> <td>1101:</td> <td>VBAT divided by 2</td> </tr> <tr> <td>0110:</td> <td>P1.4</td> <td>1110:</td> <td>VBAT Supply Voltage</td> </tr> <tr> <td>0111:</td> <td>P1.6</td> <td>1111:</td> <td>VBAT Supply Voltage</td> </tr> </tbody> </table>	0000:	P0.0	1000:	P2.0	0001:	P0.2	1001:	P2.2	0010:	P0.4	1010:	Reserved	0011:	P0.6	1011:	Reserved	0100:	Reserved	1100:	Compare	0101:	Reserved	1101:	VBAT divided by 2	0110:	P1.4	1110:	VBAT Supply Voltage	0111:	P1.6	1111:	VBAT Supply Voltage
0000:	P0.0	1000:	P2.0																															
0001:	P0.2	1001:	P2.2																															
0010:	P0.4	1010:	Reserved																															
0011:	P0.6	1011:	Reserved																															
0100:	Reserved	1100:	Compare																															
0101:	Reserved	1101:	VBAT divided by 2																															
0110:	P1.4	1110:	VBAT Supply Voltage																															
0111:	P1.6	1111:	VBAT Supply Voltage																															

Si102x/3x

SFR Definition 7.4. CPT1MX: Comparator1 Input Channel Select

Bit	7	6	5	4	3	2	1	0
Name	CMX1N[3:0]				CMX1P[3:0]			
Type	R/W	R/W	R/W	R/W	R/W	R/W	R/W	R/W
Reset	1	1	1	1	1	1	1	1

SFR Page = 0x0; SFR Address = 0x9E

Bit	Name	Function																																
7:4	CMX1N	<p>Comparator1 Negative Input Selection. Selects the negative input channel for Comparator1.</p> <table> <tr> <td>0000:</td> <td>P0.1</td> <td>1000:</td> <td>P2.1</td> </tr> <tr> <td>0001:</td> <td>P0.3</td> <td>1001:</td> <td>P2.3</td> </tr> <tr> <td>0010:</td> <td>P0.5</td> <td>1010:</td> <td>Reserved</td> </tr> <tr> <td>0011:</td> <td>Reserved</td> <td>1011:</td> <td>Reserved</td> </tr> <tr> <td>0100:</td> <td>Reserved</td> <td>1100:</td> <td>Compare</td> </tr> <tr> <td>0101:</td> <td>Reserved</td> <td>1101:</td> <td>VBAT divided by 2</td> </tr> <tr> <td>0110:</td> <td>P1.5</td> <td>1110:</td> <td>Digital Supply Voltage</td> </tr> <tr> <td>0111:</td> <td>P1.7</td> <td>1111:</td> <td>Ground</td> </tr> </table>	0000:	P0.1	1000:	P2.1	0001:	P0.3	1001:	P2.3	0010:	P0.5	1010:	Reserved	0011:	Reserved	1011:	Reserved	0100:	Reserved	1100:	Compare	0101:	Reserved	1101:	VBAT divided by 2	0110:	P1.5	1110:	Digital Supply Voltage	0111:	P1.7	1111:	Ground
0000:	P0.1	1000:	P2.1																															
0001:	P0.3	1001:	P2.3																															
0010:	P0.5	1010:	Reserved																															
0011:	Reserved	1011:	Reserved																															
0100:	Reserved	1100:	Compare																															
0101:	Reserved	1101:	VBAT divided by 2																															
0110:	P1.5	1110:	Digital Supply Voltage																															
0111:	P1.7	1111:	Ground																															
3:0	CMX1P	<p>Comparator1 Positive Input Selection. Selects the positive input channel for Comparator1.</p> <table> <tr> <td>0000:</td> <td>P0.0</td> <td>1000:</td> <td>P2.0</td> </tr> <tr> <td>0001:</td> <td>P0.2</td> <td>1001:</td> <td>P2.2</td> </tr> <tr> <td>0010:</td> <td>P0.4</td> <td>1010:</td> <td>Reserved</td> </tr> <tr> <td>0011:</td> <td>P0.6</td> <td>1011:</td> <td>Reserved</td> </tr> <tr> <td>0100:</td> <td>Reserved</td> <td>1100:</td> <td>Compare</td> </tr> <tr> <td>0101:</td> <td>Reserved</td> <td>1101:</td> <td>VBAT divided by 2</td> </tr> <tr> <td>0110:</td> <td>P1.4</td> <td>1110:</td> <td>VBAT Supply Voltage</td> </tr> <tr> <td>0111:</td> <td>P1.6</td> <td>1111:</td> <td>VDC Supply Voltage</td> </tr> </table>	0000:	P0.0	1000:	P2.0	0001:	P0.2	1001:	P2.2	0010:	P0.4	1010:	Reserved	0011:	P0.6	1011:	Reserved	0100:	Reserved	1100:	Compare	0101:	Reserved	1101:	VBAT divided by 2	0110:	P1.4	1110:	VBAT Supply Voltage	0111:	P1.6	1111:	VDC Supply Voltage
0000:	P0.0	1000:	P2.0																															
0001:	P0.2	1001:	P2.2																															
0010:	P0.4	1010:	Reserved																															
0011:	P0.6	1011:	Reserved																															
0100:	Reserved	1100:	Compare																															
0101:	Reserved	1101:	VBAT divided by 2																															
0110:	P1.4	1110:	VBAT Supply Voltage																															
0111:	P1.6	1111:	VDC Supply Voltage																															

8. CIP-51 Microcontroller

The MCU system controller core is the CIP-51 microcontroller. The CIP-51 is fully compatible with the MCS-51™ instruction set; standard 803x/805x assemblers and compilers can be used to develop software. The MCU family has a superset of all the peripherals included with a standard 8051. The CIP-51 also includes on-chip debug hardware (see description in Section 35), and interfaces directly with the analog and digital subsystems providing a complete data acquisition or control-system solution in a single integrated circuit.

The CIP-51 Microcontroller core implements the standard 8051 organization and peripherals as well as additional custom peripherals and functions to extend its capability (see Figure 8.1 for a block diagram). The CIP-51 includes the following features:

- Fully Compatible with MCS-51 Instruction Set
- 25 MIPS Peak Throughput with 25 MHz Clock
- 0 to 25 MHz Clock Frequency
- Extended Interrupt Handler
- Reset Input
- Power Management Modes
- On-chip Debug Logic
- Program and Data Memory Security

Performance

The CIP-51 employs a pipelined architecture that greatly increases its instruction throughput over the standard 8051 architecture. In a standard 8051, all instructions except for MUL and DIV take 12 or 24 system clock cycles to execute, and usually have a maximum system clock of 12 MHz. By contrast, the CIP-51 core executes 70% of its instructions in one or two system clock cycles, with no instructions taking more than eight system clock cycles.

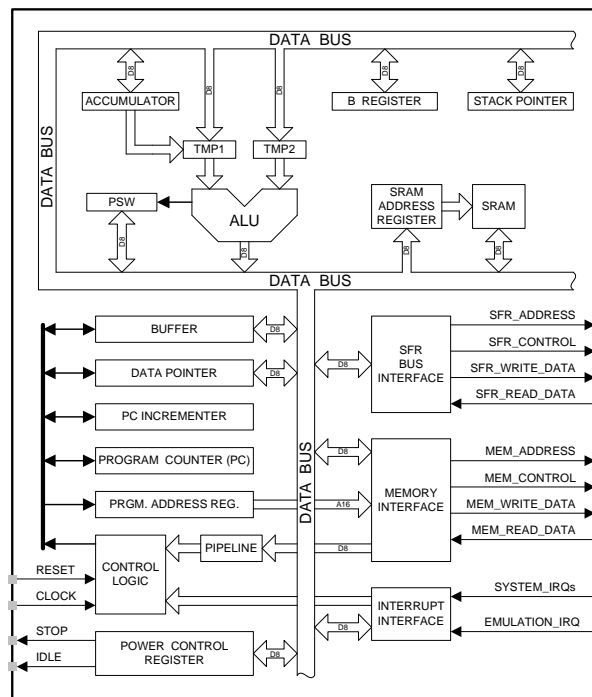

Figure 8.1. CIP-51 Block Diagram

Si102x/3x

With the CIP-51's maximum system clock at 25 MHz, it has a peak throughput of 25 MIPS. The CIP-51 has a total of 109 instructions. The table below shows the total number of instructions that require each execution time.

Clocks to Execute	1	2	2/3	3	3/4	4	4/5	5	8
Number of Instructions	26	50	5	14	7	3	1	2	1

Programming and Debugging Support

In-system programming of the flash program memory and communication with on-chip debug support logic is accomplished via the Silicon Labs 2-Wire Development Interface (C2).

The on-chip debug support logic facilitates full speed in-circuit debugging, allowing the setting of hardware breakpoints, starting, stopping and single stepping through program execution (including interrupt service routines), examination of the program's call stack, and reading/writing the contents of registers and memory. This method of on-chip debugging is completely non-intrusive, requiring no RAM, Stack, timers, or other on-chip resources. C2 details can be found in Section "35. C2 Interface" on page 533.

The CIP-51 is supported by development tools from Silicon Labs and third party vendors. Silicon Labs provides an integrated development environment (IDE) including editor, debugger and programmer. The IDE's debugger and programmer interface to the CIP-51 via the C2 interface to provide fast and efficient in-system device programming and debugging. Third party macro assemblers and C compilers are also available.

8.1. Instruction Set

The instruction set of the CIP-51 System Controller is fully compatible with the standard MCS-51™ instruction set. Standard 8051 development tools can be used to develop software for the CIP-51. All CIP-51 instructions are the binary and functional equivalent of their MCS-51™ counterparts, including opcodes, addressing modes and effect on PSW flags. However, instruction timing is different than that of the standard 8051.

8.1.1. Instruction and CPU Timing

In many 8051 implementations, a distinction is made between machine cycles and clock cycles, with machine cycles varying from 2 to 12 clock cycles in length. However, the CIP-51 implementation is based solely on clock cycle timing. All instruction timings are specified in terms of clock cycles.

Due to the pipelined architecture of the CIP-51, most instructions execute in the same number of clock cycles as there are program bytes in the instruction. Conditional branch instructions take one less clock cycle to complete when the branch is not taken as opposed to when the branch is taken. Table 8.1 is the CIP-51 Instruction Set Summary, which includes the mnemonic, number of bytes, and number of clock cycles for each instruction.

Table 8.1. CIP-51 Instruction Set Summary

Mnemonic	Description	Bytes	Clock Cycles
Arithmetic Operations			
ADD A, Rn	Add register to A	1	1
ADD A, direct	Add direct byte to A	2	2
ADD A, @Ri	Add indirect RAM to A	1	2
ADD A, #data	Add immediate to A	2	2
ADDC A, Rn	Add register to A with carry	1	1
ADDC A, direct	Add direct byte to A with carry	2	2
ADDC A, @Ri	Add indirect RAM to A with carry	1	2
ADDC A, #data	Add immediate to A with carry	2	2
SUBB A, Rn	Subtract register from A with borrow	1	1
SUBB A, direct	Subtract direct byte from A with borrow	2	2
SUBB A, @Ri	Subtract indirect RAM from A with borrow	1	2
SUBB A, #data	Subtract immediate from A with borrow	2	2
INC A	Increment A	1	1
INC Rn	Increment register	1	1
INC direct	Increment direct byte	2	2
INC @Ri	Increment indirect RAM	1	2
DEC A	Decrement A	1	1
DEC Rn	Decrement register	1	1
DEC direct	Decrement direct byte	2	2
DEC @Ri	Decrement indirect RAM	1	2
INC DPTR	Increment Data Pointer	1	1
MUL AB	Multiply A and B	1	4
DIV AB	Divide A by B	1	8
DA A	Decimal adjust A	1	1
Logical Operations			
ANL A, Rn	AND Register to A	1	1
ANL A, direct	AND direct byte to A	2	2
ANL A, @Ri	AND indirect RAM to A	1	2
ANL A, #data	AND immediate to A	2	2
ANL direct, A	AND A to direct byte	2	2
ANL direct, #data	AND immediate to direct byte	3	3
ORL A, Rn	OR Register to A	1	1
ORL A, direct	OR direct byte to A	2	2
ORL A, @Ri	OR indirect RAM to A	1	2
ORL A, #data	OR immediate to A	2	2
ORL direct, A	OR A to direct byte	2	2
ORL direct, #data	OR immediate to direct byte	3	3
XRL A, Rn	Exclusive-OR Register to A	1	1
XRL A, direct	Exclusive-OR direct byte to A	2	2
XRL A, @Ri	Exclusive-OR indirect RAM to A	1	2
XRL A, #data	Exclusive-OR immediate to A	2	2
XRL direct, A	Exclusive-OR A to direct byte	2	2
XRL direct, #data	Exclusive-OR immediate to direct byte	3	3

Table 8.1. CIP-51 Instruction Set Summary (Continued)

Mnemonic	Description	Bytes	Clock Cycles
CLR A	Clear A	1	1
CPL A	Complement A	1	1
RL A	Rotate A left	1	1
RLC A	Rotate A left through Carry	1	1
RR A	Rotate A right	1	1
RRC A	Rotate A right through Carry	1	1
SWAP A	Swap nibbles of A	1	1
Data Transfer			
MOV A, Rn	Move Register to A	1	1
MOV A, direct	Move direct byte to A	2	2
MOV A, @Ri	Move indirect RAM to A	1	2
MOV A, #data	Move immediate to A	2	2
MOV Rn, A	Move A to Register	1	1
MOV Rn, direct	Move direct byte to Register	2	2
MOV Rn, #data	Move immediate to Register	2	2
MOV direct, A	Move A to direct byte	2	2
MOV direct, Rn	Move Register to direct byte	2	2
MOV direct, direct	Move direct byte to direct byte	3	3
MOV direct, @Ri	Move indirect RAM to direct byte	2	2
MOV direct, #data	Move immediate to direct byte	3	3
MOV @Ri, A	Move A to indirect RAM	1	2
MOV @Ri, direct	Move direct byte to indirect RAM	2	2
MOV @Ri, #data	Move immediate to indirect RAM	2	2
MOV DPTR, #data16	Load DPTR with 16-bit constant	3	3
MOVC A, @A+DPTR	Move code byte relative DPTR to A	1	3
MOVC A, @A+PC	Move code byte relative PC to A	1	3
MOVX A, @Ri	Move external data (8-bit address) to A	1	3
MOVX @Ri, A	Move A to external data (8-bit address)	1	3
MOVX A, @DPTR	Move external data (16-bit address) to A	1	3
MOVX @DPTR, A	Move A to external data (16-bit address)	1	3
PUSH direct	Push direct byte onto stack	2	2
POP direct	Pop direct byte from stack	2	2
XCH A, Rn	Exchange Register with A	1	1
XCH A, direct	Exchange direct byte with A	2	2
XCH A, @Ri	Exchange indirect RAM with A	1	2
XCHD A, @Ri	Exchange low nibble of indirect RAM with A	1	2
Boolean Manipulation			
CLR C	Clear Carry	1	1
CLR bit	Clear direct bit	2	2
SETB C	Set Carry	1	1
SETB bit	Set direct bit	2	2
CPL C	Complement Carry	1	1
CPL bit	Complement direct bit	2	2
ANL C, bit	AND direct bit to Carry	2	2

Table 8.1. CIP-51 Instruction Set Summary (Continued)

Mnemonic	Description	Bytes	Clock Cycles
ANL C, /bit	AND complement of direct bit to Carry	2	2
ORL C, bit	OR direct bit to carry	2	2
ORL C, /bit	OR complement of direct bit to Carry	2	2
MOV C, bit	Move direct bit to Carry	2	2
MOV bit, C	Move Carry to direct bit	2	2
JC rel	Jump if Carry is set	2	2/3
JNC rel	Jump if Carry is not set	2	2/3
JB bit, rel	Jump if direct bit is set	3	3/4
JNB bit, rel	Jump if direct bit is not set	3	3/4
JBC bit, rel	Jump if direct bit is set and clear bit	3	3/4
Program Branching			
ACALL addr11	Absolute subroutine call	2	3
LCALL addr16	Long subroutine call	3	4
RET	Return from subroutine	1	5
RETI	Return from interrupt	1	5
AJMP addr11	Absolute jump	2	3
LJMP addr16	Long jump	3	4
SJMP rel	Short jump (relative address)	2	3
JMP @A+DPTR	Jump indirect relative to DPTR	1	3
JZ rel	Jump if A equals zero	2	2/3
JNZ rel	Jump if A does not equal zero	2	2/3
CJNE A, direct, rel	Compare direct byte to A and jump if not equal	3	3/4
CJNE A, #data, rel	Compare immediate to A and jump if not equal	3	3/4
CJNE Rn, #data, rel	Compare immediate to Register and jump if not equal	3	3/4
CJNE @Ri, #data, rel	Compare immediate to indirect and jump if not equal	3	4/5
DJNZ Rn, rel	Decrement Register and jump if not zero	2	2/3
DJNZ direct, rel	Decrement direct byte and jump if not zero	3	3/4
NOP	No operation	1	1

Notes on Registers, Operands and Addressing Modes:

Rn—Register R0–R7 of the currently selected register bank.

@Ri—Data RAM location addressed indirectly through R0 or R1.

rel—8-bit, signed (twos complement) offset relative to the first byte of the following instruction. Used by SJMP and all conditional jumps.

direct—8-bit internal data location's address. This could be a direct-access Data RAM location (0x00–0x7F) or an SFR (0x80–0xFF).

#data—8-bit constant

#data16—16-bit constant

bit—Direct-accessed bit in Data RAM or SFR

addr11—11-bit destination address used by ACALL and AJMP. The destination must be within the same 2 kB page of program memory as the first byte of the following instruction.

addr16—16-bit destination address used by LCALL and LJMP. The destination may be anywhere within the 8 kB program memory space.

There is one unused opcode (0xA5) that performs the same function as NOP.
All mnemonics copyrighted © Intel Corporation 1980.

8.2. CIP-51 Register Descriptions

Following are descriptions of SFRs related to the operation of the CIP-51 System Controller. Reserved bits should not be set to logic 1. Future product versions may use these bits to implement new features in which case the reset value of the bit will be logic 0, selecting the feature's default state. Detailed descriptions of the remaining SFRs are included in the sections of the data sheet associated with their corresponding system function.

SFR Definition 8.1. DPL: Data Pointer Low Byte

Bit	7	6	5	4	3	2	1	0
Name	DPL[7:0]							
Type	R/W							
Reset	0	0	0	0	0	0	0	0

SFR Page = All Pages; SFR Address = 0x82

Bit	Name	Function
7:0	DPL[7:0]	Data Pointer Low. The DPL register is the low byte of the 16-bit DPTR. DPTR is used to access indirectly addressed flash memory or XRAM.

SFR Definition 8.2. DPH: Data Pointer High Byte

Bit	7	6	5	4	3	2	1	0
Name	DPH[7:0]							
Type	R/W							
Reset	0	0	0	0	0	0	0	0

SFR Page = All Pages; SFR Address = 0x83

Bit	Name	Function
7:0	DPH[7:0]	Data Pointer High. The DPH register is the high byte of the 16-bit DPTR. DPTR is used to access indirectly addressed flash memory or XRAM.

Si102x/3x

SFR Definition 8.3. SP: Stack Pointer

Bit	7	6	5	4	3	2	1	0
Name	SP[7:0]							
Type	R/W							
Reset	0	0	0	0	0	1	1	1

SFR Page = All Pages; SFR Address = 0x81

Bit	Name	Function
7:0	SP[7:0]	Stack Pointer. The Stack Pointer holds the location of the top of the stack. The stack pointer is incremented before every PUSH operation. The SP register defaults to 0x07 after reset.

SFR Definition 8.4. ACC: Accumulator

Bit	7	6	5	4	3	2	1	0
Name	ACC[7:0]							
Type	R/W							
Reset	0	0	0	0	0	0	0	0

SFR Page = All Pages; SFR Address = 0xE0; Bit-Addressable

Bit	Name	Function
7:0	ACC[7:0]	Accumulator. This register is the accumulator for arithmetic operations.

SFR Definition 8.5. B: B Register

Bit	7	6	5	4	3	2	1	0
Name	B[7:0]							
Type	R/W							
Reset	0	0	0	0	0	0	0	0

SFR Page = All Pages; SFR Address = 0xF0; Bit-Addressable

Bit	Name	Function
7:0	B[7:0]	B Register. This register serves as a second accumulator for certain arithmetic operations.

SFR Definition 8.6. PSW: Program Status Word

Bit	7	6	5	4	3	2	1	0
Name	CY	AC	F0	RS[1:0]		OV	F1	PARITY
Type	R/W	R/W	R/W	R/W		R/W	R/W	R
Reset	0	0	0	0	0	0	0	0

SFR Page = All Pages; SFR Address = 0xD0; Bit-Addressable

Bit	Name	Function
7	CY	Carry Flag. This bit is set when the last arithmetic operation resulted in a carry (addition) or a borrow (subtraction). It is cleared to logic 0 by all other arithmetic operations.
6	AC	Auxiliary Carry Flag. This bit is set when the last arithmetic operation resulted in a carry into (addition) or a borrow from (subtraction) the high order nibble. It is cleared to logic 0 by all other arithmetic operations.
5	F0	User Flag 0. This is a bit-addressable, general purpose flag for use under software control.
4:3	RS[1:0]	Register Bank Select. These bits select which register bank is used during register accesses. 00: Bank 0, Addresses 0x00-0x07 01: Bank 1, Addresses 0x08-0x0F 10: Bank 2, Addresses 0x10-0x17 11: Bank 3, Addresses 0x18-0x1F
2	OV	Overflow Flag. This bit is set to 1 under the following circumstances: <ul style="list-style-type: none"> ■ An ADD, ADDC, or SUBB instruction causes a sign-change overflow. ■ A MUL instruction results in an overflow (result is greater than 255). ■ A DIV instruction causes a divide-by-zero condition. The OV bit is cleared to 0 by the ADD, ADDC, SUBB, MUL, and DIV instructions in all other cases.
1	F1	User Flag 1. This is a bit-addressable, general purpose flag for use under software control.
0	PARITY	Parity Flag. This bit is set to logic 1 if the sum of the eight bits in the accumulator is odd and cleared if the sum is even.

Si102x/3x

9. Memory Organization

The memory organization of the CIP-51 System Controller is similar to that of a standard 8051. There are two separate memory spaces: program memory and data memory. Program and data memory share the same address space but are accessed via different instruction types. The memory organization of the Si102x/3x device family is shown in Figure 9.1

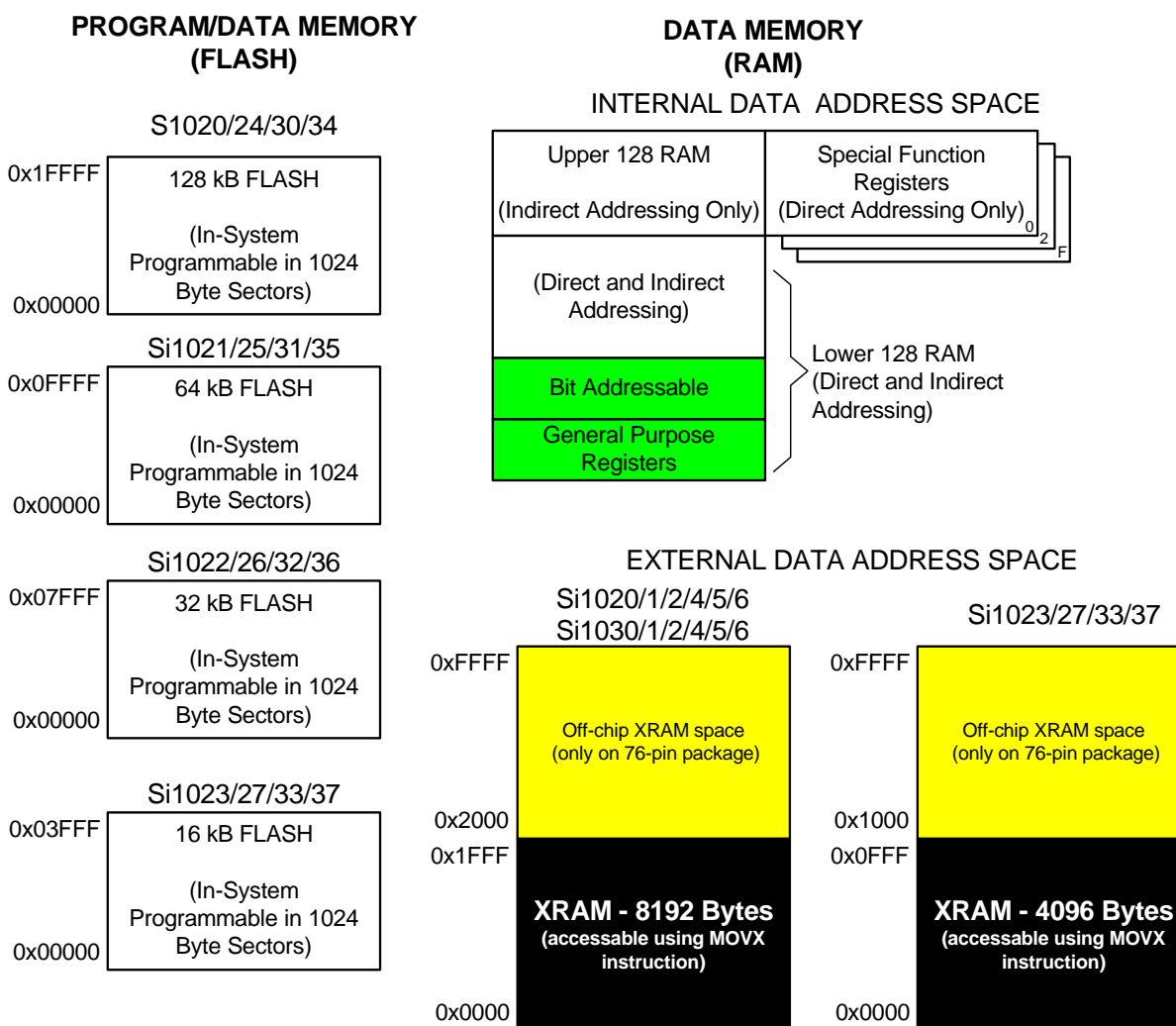

Figure 9.1. Si102x/3x Memory Map

9.1. Program Memory

The Si1020/24/30/34 devices have a 128 kB program memory space, Si1021/25/31/35 devices have a 64 kB program memory space, Si1022/26/32/36 devices have a 32 kB program memory space, and Si1023/27/33/37 devices have a 16 kB program memory space. The devices with 128 kB of program memory space implement this as in-system re-programmable flash memory in four 32 kB code banks. A common code bank (Bank 0) of 32 kB is always accessible from addresses 0x0000 to 0x7FFF. The upper code banks (Bank 1, Bank 2, and Bank 3) are each mapped to addresses 0x8000 to 0xFFFF, depending

on the selection of bits in the PSBANK register, as described in SFR Definition 9.1. All other devices with 64 kB or less of program memory can be used as non-banked devices.

The IFBANK bits select which of the upper banks are used for code execution, while the COBANK bits select the bank to be used for direct writes and reads of the flash memory.

The address 0x1FFFF (Si1020/24/30/34), 0xFFFF (Si1021/25/31/35), 0x07FFF (Si1022/26/32/36), or 0x3FFF (Si1023/27/33/37) serves as the security lock byte for the device. Any addresses above the lock byte are reserved.

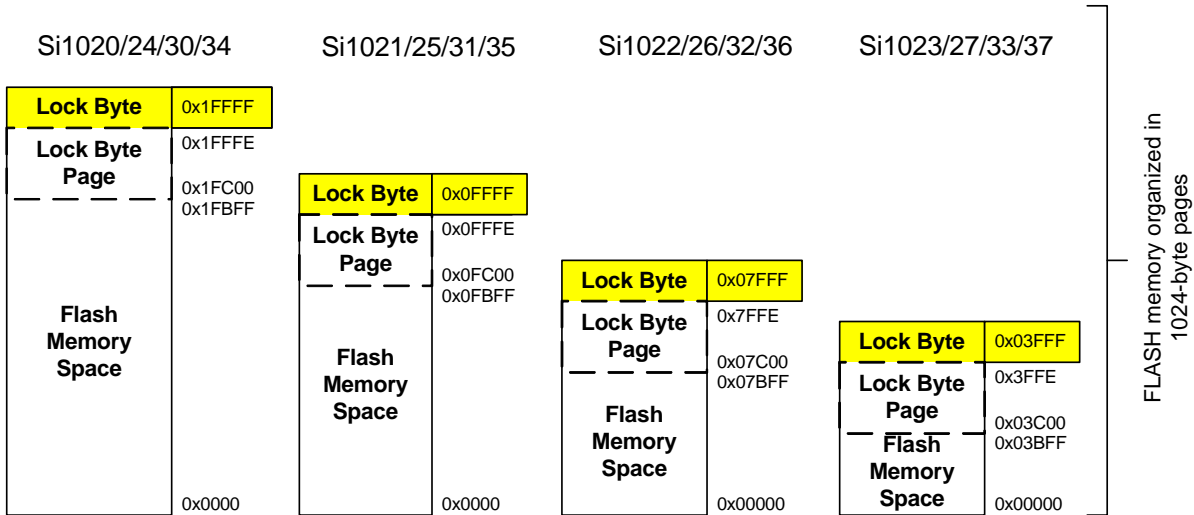

Figure 9.2. Flash Program Memory Map

Si102x/3x

Internal Address	IFBANK=0	IFBANK=1	IFBANK=2	IFBANK=3
0xFFFF	Bank0	Bank1	Bank2	Bank3
0x8000				
0x7FFF	Bank0	Bank0	Bank0	Bank0
0x0000				

Figure 9.3. Address Memory Map for Instruction Fetches

SFR Definition 9.1. PSBANK: Program Space Bank Select

Bit	7	6	5	4	3	2	1	0
Name	COBANK[1:0]				IFBANK[1:0]			
Type	R/W	R/W	R/W	R/W	R/W	R/W	R/W	R/W
Reset	0	0	0	0	0	0	0	0

SFR Page = All Pages; SFR Address = 0x84

Bit	Name	Function
7:6	Reserved	Read = 00b, Must Write = 00b.
5:4	COBANK[1:0]	Constant Operations Bank Select. These bits select which flash bank is targeted during constant operations (MOVC and flash MOVX) involving address 0x8000 to 0xFFFF. 00: Constant Operations Target Bank 0 (note that Bank 0 is also mapped between 0x0000 to 0x7FFF). 01: Constant operations target Bank 1. 10: Constant operations target Bank 2. 11: Constant operations target Bank 3.
3:2	Reserved	Read = 00b, Must Write = 00b.
1:0	IFBANK[1:0]	Instruction Fetch Operations Bank Select. These bits select which flash bank is used for instruction fetches involving address 0x8000 to 0xFFFF. These bits can only be changed from code in Bank 0. 00: Instructions fetch from Bank 0 (note that Bank 0 is also mapped between 0x0000 to 0x7FFF). 01: Instructions fetch from Bank 1. 10: Instructions fetch from Bank 2. 11: Instructions fetch from Bank 3.
Note: <ol style="list-style-type: none"> COBANK[1:0] and IFBANK[1:0] should not be set to select any bank other than Bank 0 (00b) on the Si1022/23/26/27/32/33/36/37 devices. COBANK[1:0] and IFBANK[1:0] should not be set to select Bank 2 (10b) or Bank 3 (11b) on the Si1021/25/31/35 devices. 		

9.1.1. MOVX Instruction and Program Memory

The MOVX instruction in an 8051 device is typically used to access external data memory. On the Si102x/3x devices, the MOVX instruction is normally used to read and write on-chip XRAM, but can be re-configured to write and erase on-chip flash memory space. MOVC instructions are always used to read flash memory, while MOVX write instructions are used to erase and write flash. This flash access feature provides a mechanism for the Si102x/3x to update program code and use the program memory space for non-volatile data storage. Refer to Section “18. Flash Memory” on page 250 for further details.

9.2. Data Memory

The Si102x/3x device family includes 8448 bytes (Si1020/21/22/25/26/27/30/31/35/36/37) or 4352 bytes (Si1023/27/33/37) of RAM data memory. 256 bytes of this memory is mapped into the internal RAM space

Si102x/3x

of the 8051. 8192 or 4096 bytes of this memory is on-chip “external” memory. The data memory map is shown in Figure 9.1 for reference.

9.2.1. Internal RAM

There are 256 bytes of internal RAM mapped into the data memory space from 0x00 through 0xFF. The lower 128 bytes of data memory are used for general purpose registers and scratch pad memory. Either direct or indirect addressing may be used to access the lower 128 bytes of data memory. Locations 0x00 through 0x1F are addressable as four banks of general purpose registers, each bank consisting of eight byte-wide registers. The next 16 bytes, locations 0x20 through 0x2F, may either be addressed as bytes or as 128 bit locations accessible with the direct addressing mode.

The upper 128 bytes of data memory are accessible only by indirect addressing. This region occupies the same address space as the Special Function Registers (SFR) but is physically separate from the SFR space. The addressing mode used by an instruction when accessing locations above 0x7F determines whether the CPU accesses the upper 128 bytes of data memory space or the SFRs. Instructions that use direct addressing will access the SFR space. Instructions using indirect addressing above 0x7F access the upper 128 bytes of data memory. Figure 9.1 illustrates the data memory organization of the Si102x/3x.

9.2.1.1. General Purpose Registers

The lower 32 bytes of data memory, locations 0x00 through 0x1F, may be addressed as four banks of general-purpose registers. Each bank consists of eight byte-wide registers designated R0 through R7. Only one of these banks may be enabled at a time. Two bits in the program status word, RS0 (PSW.3) and RS1 (PSW.4), select the active register bank (see description of the PSW in SFR Definition 8.6). This allows fast context switching when entering subroutines and interrupt service routines. Indirect addressing modes use registers R0 and R1 as index registers.

9.2.1.2. Bit Addressable Locations

In addition to direct access to data memory organized as bytes, the sixteen data memory locations at 0x20 through 0x2F are also accessible as 128 individually addressable bits. Each bit has a bit address from 0x00 to 0x7F. Bit 0 of the byte at 0x20 has bit address 0x00 while bit7 of the byte at 0x20 has bit address 0x07. Bit 7 of the byte at 0x2F has bit address 0x7F. A bit access is distinguished from a full byte access by the type of instruction used (bit source or destination operands as opposed to a byte source or destination).

The MCS-51™ assembly language allows an alternate notation for bit addressing of the form XX.B where XX is the byte address and B is the bit position within the byte. For example, the instruction:

```
MOV    C, 22.3h
```

moves the Boolean value at 0x13 (bit 3 of the byte at location 0x22) into the Carry flag.

9.2.1.3. Stack

A programmer's stack can be located anywhere in the 256-byte data memory. The stack area is designated using the Stack Pointer (SP) SFR. The SP will point to the last location used. The next value pushed on the stack is placed at SP+1 and then SP is incremented. A reset initializes the stack pointer to location 0x07. Therefore, the first value pushed on the stack is placed at location 0x08, which is also the first register (R0) of register bank 1. Thus, if more than one register bank is to be used, the SP should be initialized to a location in the data memory not being used for data storage. The stack depth can extend up to 256 bytes.

9.2.2. External RAM

There are 8192 bytes or 4096 bytes of on-chip RAM mapped into the external data memory space. All of these address locations may be accessed using the external move instruction (MOVX) and the data pointer (DPTR), or using MOVX indirect addressing mode (such as @R1) in combination with the EMIOCN register. Additional off-chip memory or memory-mapped devices may be mapped to the external memory

address space and accessed using the external memory interface. See Section “10. External Data Memory Interface and On-Chip XRAM” on page 130 for further details.

10. External Data Memory Interface and On-Chip XRAM

An External Memory Interface (EMIF) is available on the Si102x/3x devices, which can be used to access off-chip data memories and memory-mapped devices connected to the GPIO ports. The external memory space may be accessed using the external move instruction (MOVX) and the data pointer (DPTR), or using the MOVX indirect addressing mode using R0 or R1. If the MOVX instruction is used with an 8-bit address operand (such as @R1), then the high byte of the 16-bit address is provided by the External Memory Interface Control Register (EMIOCN, shown in SFR Definition 10.1).

Note: The MOVX instruction can also be used for writing to the flash memory. See Section “18. Flash Memory” on page 250 for details. The MOVX instruction accesses XRAM by default.

10.1. Accessing XRAM

The XRAM memory space is accessed using the MOVX instruction. The MOVX instruction has two forms, both of which use an indirect addressing method. The first method uses the Data Pointer, DPTR, a 16-bit register which contains the effective address of the XRAM location to be read from or written to. The second method uses R0 or R1 in combination with the EMIOCN register to generate the effective XRAM address. Examples of both of these methods are given below.

10.1.1. 16-Bit MOVX Example

The 16-bit form of the MOVX instruction accesses the memory location pointed to by the contents of the DPTR register. The following series of instructions reads the value of the byte at address 0x1234 into the accumulator A:

```
MOV    DPTR, #1234h           ; load DPTR with 16-bit address to read (0x1234)
MOVX   A, @DPTR              ; load contents of 0x1234 into accumulator A
```

The above example uses the 16-bit immediate MOV instruction to set the contents of DPTR. Alternately, the DPTR can be accessed through the SFR registers DPH, which contains the upper 8-bits of DPTR, and DPL, which contains the lower 8-bits of DPTR.

10.1.2. 8-Bit MOVX Example

The 8-bit form of the MOVX instruction uses the contents of the EMIOCN SFR to determine the upper 8-bits of the effective address to be accessed and the contents of R0 or R1 to determine the lower 8-bits of the effective address to be accessed. The following series of instructions read the contents of the byte at address 0x1234 into the accumulator A.

```
MOV    EMIOCN, #12h          ; load high byte of address into EMIOCN
MOV    R0, #34h              ; load low byte of address into R0 (or R1)
MOVX   a, @R0                ; load contents of 0x1234 into accumulator A
```

10.2. Configuring the External Memory Interface

Configuring the EMIF consists of five steps:

1. Configure the output modes of the associated port pins as either push-pull or open-drain (push-pull is most common). The input mode of the associated port pins should be set to digital (reset value).
2. Configure port latches to “park” the EMIF pins in a dormant state (usually by setting them to logic 1).
3. Select Multiplexed mode or Non-Multiplexed mode.
4. Select the memory mode (on-chip only, split mode without bank select, split mode with bank select, or off-chip only).
5. Set up timing to interface with off-chip memory or peripherals.

Each of these five steps is explained in detail in the following sections. The port selection, Multiplexed mode selection, and mode bits are located in the EMI0CF register shown in SFR Definition .

10.3. Port Configuration

The EMIF appears on Ports 3, 4, 5, and 6 when it is used for off-chip memory access. The EMIF and the LCD cannot be used simultaneously. When using EMIF, all pins on Ports 3-6 may only be used for EMIF purposes or as general purpose I/O. The EMIF pinout is shown in Table 10.1 on page 132.

The EMIF claims the associated port pins for memory operations ONLY during the execution of an off-chip MOVX instruction. Once the MOVX instruction has completed, control of the port pins reverts to the port latches or to the crossbar settings for those pins. See Section “27. Port Input/Output” on page 358 for more information about the crossbar and port operation and configuration. **The port latches should be explicitly configured to “park” the EMIF pins in a dormant state, most commonly by setting them to a logic 1.**

During the execution of the MOVX instruction, the EMIF will explicitly disable the drivers on all port pins that are acting as inputs (Data[7:0] during a READ operation, for example). The output mode of the port pins (whether the pin is configured as open-drain or push-pull) is unaffected by the EMIF operation, and remains controlled by the PnMDOUT registers. In most cases, the output modes of all EMIF pins should be configured for push-pull mode.

The Si102x/3x devices support both the Multiplexed and Non-Multiplexed modes.

Table 10.1. EMIF Pinout

Multiplexed Mode			Non Multiplexed Mode		
Signal Name	Port Pin		Signal Name	Port Pin	
	8-Bit Mode ¹	16-Bit Mode ²		8-Bit Mode ¹	16-Bit Mode ²
\overline{RD}	P3.6	P3.6	\overline{RD}	P3.6	P3.6
\overline{WR}	P3.7	P3.7	\overline{WR}	P3.7	P3.7
ALE	P3.5	P3.5	D0	P6.0	P6.0
AD0	P6.0	P6.0	D1	P6.1	P6.1
AD1	P6.1	P6.1	D2	P6.2	P6.2
AD2	P6.2	P6.2	D3	P6.3	P6.3
AD3	P6.3	P6.3	D4	P6.4	P6.4
AD4	P6.4	P6.4	D5	P6.5	P6.5
AD5	P6.5	P6.5	D6	P6.6	P6.6
AD6	P6.6	P6.6	D7	P6.7	P6.7
AD7	P6.7	P6.7	A0	P5.0	P5.0
A8	—	P5.0	A1	P5.1	P5.1
A9	—	P5.1	A2	P5.2	P5.2
A10	—	P5.2	A3	P5.3	P5.3
A11	—	P5.3	A4	P5.4	P5.4
A12	—	P5.4	A5	P5.5	P5.5
A13	—	P5.5	A6	P5.6	P5.6
A14	—	P5.6	A7	P5.7	P5.7
A15	—	P5.7	A8	—	P4.0
—	—	—	A9	—	P4.1
—	—	—	A10	—	P4.2
—	—	—	A11	—	P4.3
—	—	—	A12	—	P4.4
—	—	—	A13	—	P4.5
—	—	—	A14	—	P4.6
—	—	—	A15	—	P4.7
Required I/O:	11	19	Required I/O:	18	26

Notes:

- Using 8-bit movx instruction without bank select.
- Using 16-bit movx instruction.

SFR Definition 10.1. EMI0CN: External Memory Interface Control

Bit	7	6	5	4	3	2	1	0
Name	PGSEL[7:0]							
Type	R/W							
Reset	0	0	0	0	0	0	0	0

SFR Page = 0x0; SFR Address = 0xAA

Bit	Name	Function
7:0	PGSEL[7:0]	XRAM Page Select Bits. The XRAM Page Select Bits provide the high byte of the 16-bit external data memory address when using an 8-bit MOVX command, effectively selecting a 256-byte page of RAM. 0x00: 0x0000 to 0x00FF 0x01: 0x0100 to 0x01FF ... 0xFE: 0xFE00 to 0xFEFF 0xFF: 0xFF00 to 0xFFFF

SFR Definition 10.2. EMI0CF: External Memory Configuration

Bit	7	6	5	4	3	2	1	0
Name				EMD2	EMD[1:0]		EALE[1:0]	
Type	R/W							
Reset	0	0	0	0	0	0	1	1

SFR Page = 0x0; SFR Address = 0xAB

Bit	Name	Function
7:5	Unused	Read = 000b; Write = Don't Care.
4	EMD2	EMIF Multiplex Mode Select Bit. 0: EMIF operates in Multiplexed Address/Data mode 1: EMIF operates in Non-Multiplexed mode (separate address and data pins)
3:2	EMD[1:0]	EMIF Operating Mode Select Bits. 00: Internal Only: MOVX accesses on-chip XRAM only. All effective addresses alias to on-chip memory space 01: Split Mode without Bank Select: Accesses below the 8 kB boundary are directed on-chip. Accesses above the 8 kB boundary are directed off-chip. 8-bit off-chip MOVX operations use current contents of the Address high port latches to resolve the upper address byte. To access off chip space, EMI0CN must be set to a page that is not contained in the on-chip address space. 10: Split Mode with Bank Select: Accesses below the 8 kB boundary are directed on-chip. Accesses above the 8 kB boundary are directed off-chip. 8-bit off-chip MOVX operations uses the contents of EMI0CN to determine the high-byte of the address. 11: External Only: MOVX accesses off-chip XRAM only. On-chip XRAM is not visible to the CPU.
1:0	EALE[1:0]	ALE Pulse-Width Select Bits. These bits only have an effect when EMD2 = 0. 00: ALE high and ALE low pulse width = 1 SYCLK cycle. 01: ALE high and ALE low pulse width = 2 SYCLK cycles. 10: ALE high and ALE low pulse width = 3 SYCLK cycles. 11: ALE high and ALE low pulse width = 4 SYCLK cycles.

10.4. Multiplexed and Non-Multiplexed Selection

The External Memory Interface is capable of acting in a Multiplexed mode or Non-Multiplexed mode, depending on the state of the EMD2 (EMIOCF.4) bit.

10.4.1. Multiplexed Configuration

In Multiplexed mode, the data bus and the lower 8 bits of the address bus share the same port pins: AD[7:0]. In this mode, an external latch (74HC373 or equivalent logic gate) is used to hold the lower 8 bits of the RAM address. The external latch is controlled by the ALE (Address Latch Enable) signal, which is driven by the EMIF logic. An example of a Multiplexed configuration is shown in Figure 10.1.

In Multiplexed mode, the external MOVX operation can be broken into two phases delineated by the state of the ALE signal. During the first phase, ALE is high and the lower 8 bits of the address bus are presented to AD[7:0]. During this phase, the address latch is configured such that the Q outputs reflect the states of the D inputs. When ALE falls, signaling the beginning of the second phase, the address latch outputs remain fixed and are no longer dependent on the latch inputs. Later in the second phase, the data bus controls the state of the AD[7:0] port at the time \overline{RD} or \overline{WR} is asserted.

See Section “10.6.2. Multiplexed Mode” on page 143 for more information.

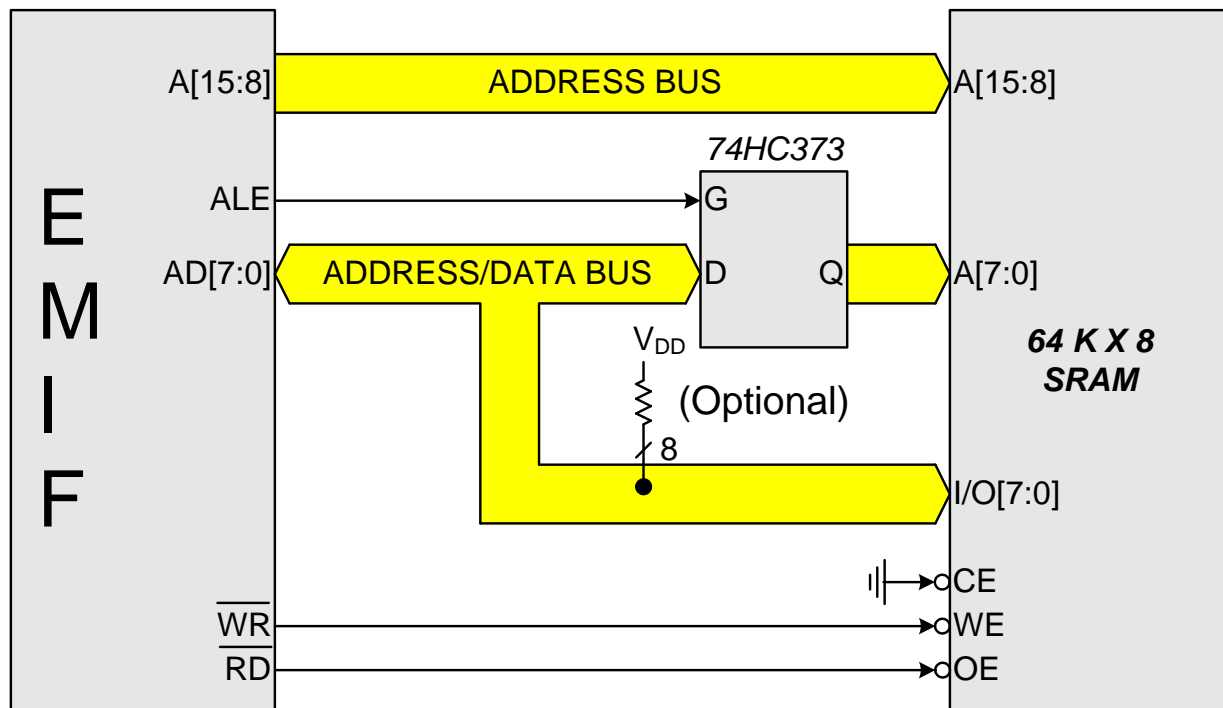

Figure 10.1. Multiplexed Configuration Example

10.4.2. Non-Multiplexed Configuration

In Non-Multiplexed mode, the data bus and the address bus pins are not shared. An example of a non-multiplexed configuration is shown in Figure 10.2. See Section “10.6.1. Non-Multiplexed Mode” on page 140 for more information about non-multiplexed operation.

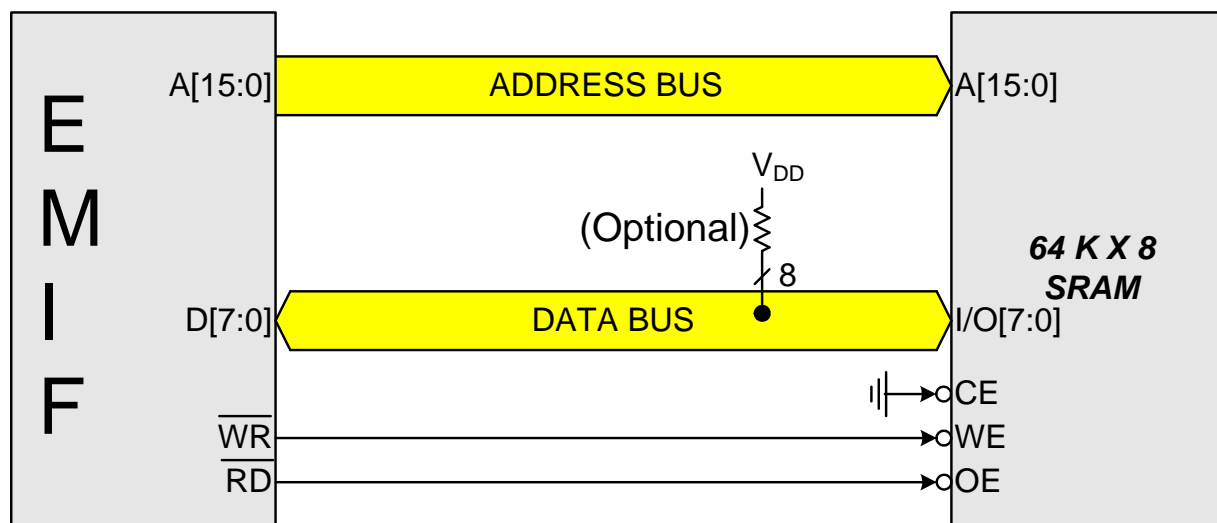

Figure 10.2. Non-Multiplexed Configuration Example

10.5. Memory Mode Selection

The external data memory space can be configured in one of four modes, shown in Figure 10.3, based on the EMIF Mode bits in the EMI0CF register (SFR Definition 10.2). These modes are summarized below. More information about the different modes can be found in Section “10.6. Timing” on page 138.

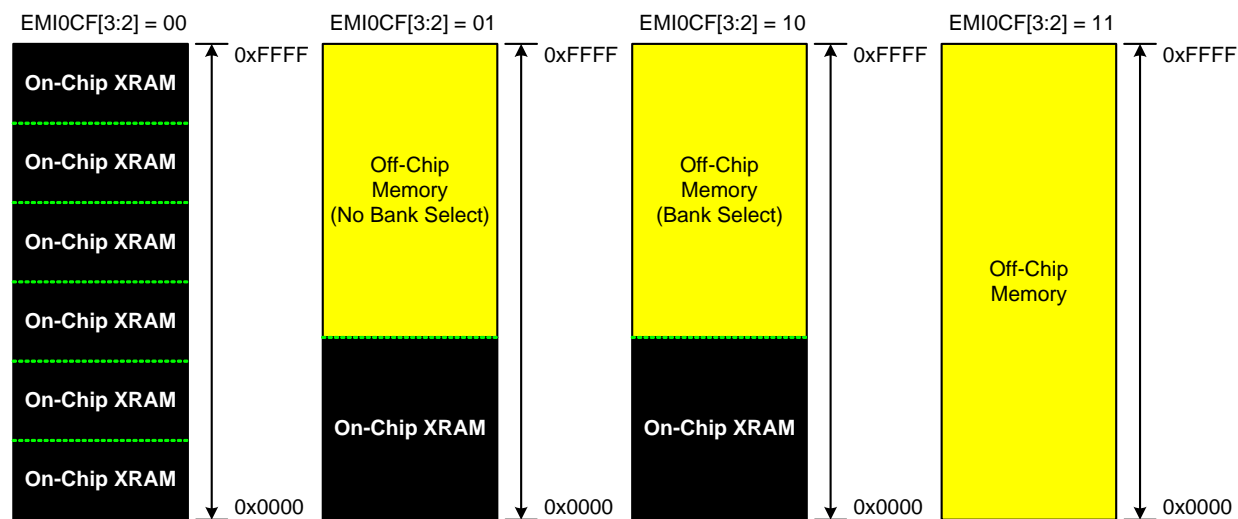

Figure 10.3. EMIF Operating Modes

10.5.1. Internal XRAM Only

When bits EMI0CF[3:2] are set to 00, all MOVX instructions will target the internal XRAM space on the device. Memory accesses to addresses beyond the populated space will wrap on 8 kB boundaries. As an example, the addresses 0x2000 and 0x4000 both evaluate to address 0x0000 in on-chip XRAM space.

- 8-bit MOVX operations use the contents of EMI0CN to determine the high-byte of the effective address and R0 or R1 to determine the low-byte of the effective address.
- 16-bit MOVX operations use the contents of the 16-bit DPTR to determine the effective address.

10.5.2. Split Mode without Bank Select

When bit EMI0CF.[3:2] are set to 01, the XRAM memory map is split into two areas, on-chip space and off-chip space.

- Effective addresses below the internal XRAM size boundary will access on-chip XRAM space.
- Effective addresses above the internal XRAM size boundary will access off-chip space.
- 8-bit MOVX operations use the contents of EMI0CN to determine whether the memory access is on-chip or off-chip. However, in the “No Bank Select” mode, an 8-bit MOVX operation will not drive the upper 8-bits A[15:8] of the Address Bus during an off-chip access. This allows the user to manipulate the upper address bits at will by setting the Port state directly via the port latches. This behavior is in contrast with “Split Mode with Bank Select” described below. The lower 8-bits of the Address Bus A[7:0] are driven, determined by R0 or R1.
- 16-bit MOVX operations use the contents of DPTR to determine whether the memory access is on-chip or off-chip, and unlike 8-bit MOVX operations, the full 16-bits of the Address Bus A[15:0] are driven during the off-chip transaction.

10.5.3. Split Mode with Bank Select

When EMI0CF[3:2] are set to 10, the XRAM memory map is split into two areas, on-chip space and off-chip space.

- Effective addresses below the internal XRAM size boundary will access on-chip XRAM space.
- Effective addresses above the internal XRAM size boundary will access off-chip space.
- 8-bit MOVX operations use the contents of EMI0CN to determine whether the memory access is on-chip or off-chip. The upper 8-bits of the Address Bus A[15:8] are determined by EMI0CN, and the lower 8-bits of the Address Bus A[7:0] are determined by R0 or R1. All 16-bits of the Address Bus A[15:0] are driven in “Bank Select” mode.
- 16-bit MOVX operations use the contents of DPTR to determine whether the memory access is on-chip or off-chip, and the full 16-bits of the Address Bus A[15:0] are driven during the off-chip transaction.

10.5.4. External Only

When EMI0CF[3:2] are set to 11, all MOVX operations are directed to off-chip space. On-chip XRAM is not visible to the CPU. This mode is useful for accessing off-chip memory located between 0x0000 and the internal XRAM size boundary.

- 8-bit MOVX operations ignore the contents of EMI0CN. The upper Address bits A[15:8] are not driven (identical behavior to an off-chip access in “Split Mode without Bank Select” described above). This allows the user to manipulate the upper address bits at will by setting the Port state directly. The lower 8-bits of the effective address A[7:0] are determined by the contents of R0 or R1.
- 16-bit MOVX operations use the contents of DPTR to determine the effective address A[15:0]. The full 16-bits of the Address Bus A[15:0] are driven during the off-chip transaction.

10.6. Timing

The timing parameters of the EMIF can be configured to enable connection to devices having different setup and hold time requirements. The address setup time, address hold time, \overline{RD} and \overline{WR} strobe widths, and in Multiplexed mode, the width of the ALE pulse are all programmable in units of SYSCLK periods through EMI0TC, shown in SFR Definition 10.3, and EMI0CF[1:0].

The timing for an off-chip MOVX instruction can be calculated by adding 4 SYSCLK cycles to the timing parameters defined by the EMI0TC register. Assuming Non-Multiplexed operation, the minimum execution time for an off-chip XRAM operation is 5 SYSCLK cycles (1 SYSCLK for \overline{RD} or \overline{WR} pulse + 4 SYSCLKs). For multiplexed operations, the Address Latch Enable signal will require a minimum of 2 additional SYSCLK cycles. Therefore, the minimum execution time for an off-chip XRAM operation in Multiplexed mode is 7 SYSCLK cycles (2 for \overline{ALE} + 1 for \overline{RD} or \overline{WR} + 4). The programmable setup and hold times default to the maximum delay settings after a reset. Table 10.2 lists the ac parameters for the EMIF, and Figure 10.4 through Figure 10.9 show the timing diagrams for the different EMIF modes and MOVX operations.

SFR Definition 10.3. EMI0TC: External Memory Timing Control

Bit	7	6	5	4	3	2	1	0
Name	EAS[1:0]		EWR[3:0]				EAH[1:0]	
Type	R/W		R/W				R/W	
Reset	1	1	1	1	1	1	1	1

SFR Page = 0x0; SFR Address = 0xAF

Bit	Name	Function
7:6	EAS[1:0]	EMIF Address Setup Time Bits. 00: Address setup time = 0 SYSCLK cycles. 01: Address setup time = 1 SYSCLK cycle. 10: Address setup time = 2 SYSCLK cycles. 11: Address setup time = 3 SYSCLK cycles.
5:2	EWR[3:0]	EMIF \overline{WR} and \overline{RD} Pulse-Width Control Bits. 0000: \overline{WR} and \overline{RD} pulse width = 1 SYSCLK cycle. 0001: \overline{WR} and \overline{RD} pulse width = 2 SYSCLK cycles. 0010: \overline{WR} and \overline{RD} pulse width = 3 SYSCLK cycles. 0011: \overline{WR} and \overline{RD} pulse width = 4 SYSCLK cycles. 0100: \overline{WR} and \overline{RD} pulse width = 5 SYSCLK cycles. 0101: \overline{WR} and \overline{RD} pulse width = 6 SYSCLK cycles. 0110: \overline{WR} and \overline{RD} pulse width = 7 SYSCLK cycles. 0111: \overline{WR} and \overline{RD} pulse width = 8 SYSCLK cycles. 1000: \overline{WR} and \overline{RD} pulse width = 9 SYSCLK cycles. 1001: \overline{WR} and \overline{RD} pulse width = 10 SYSCLK cycles. 1010: \overline{WR} and \overline{RD} pulse width = 11 SYSCLK cycles. 1011: \overline{WR} and \overline{RD} pulse width = 12 SYSCLK cycles. 1100: \overline{WR} and \overline{RD} pulse width = 13 SYSCLK cycles. 1101: \overline{WR} and \overline{RD} pulse width = 14 SYSCLK cycles. 1110: \overline{WR} and \overline{RD} pulse width = 15 SYSCLK cycles. 1111: \overline{WR} and \overline{RD} pulse width = 16 SYSCLK cycles.
1:0	EAH[1:0]	EMIF Address Hold Time Bits. 00: Address hold time = 0 SYSCLK cycles. 01: Address hold time = 1 SYSCLK cycle. 10: Address hold time = 2 SYSCLK cycles. 11: Address hold time = 3 SYSCLK cycles.

Si102x/3x

10.6.1. Non-Multiplexed Mode

10.6.1.1. 16-bit MOVX: EMI0CF[4:2] = 101, 110, or 111

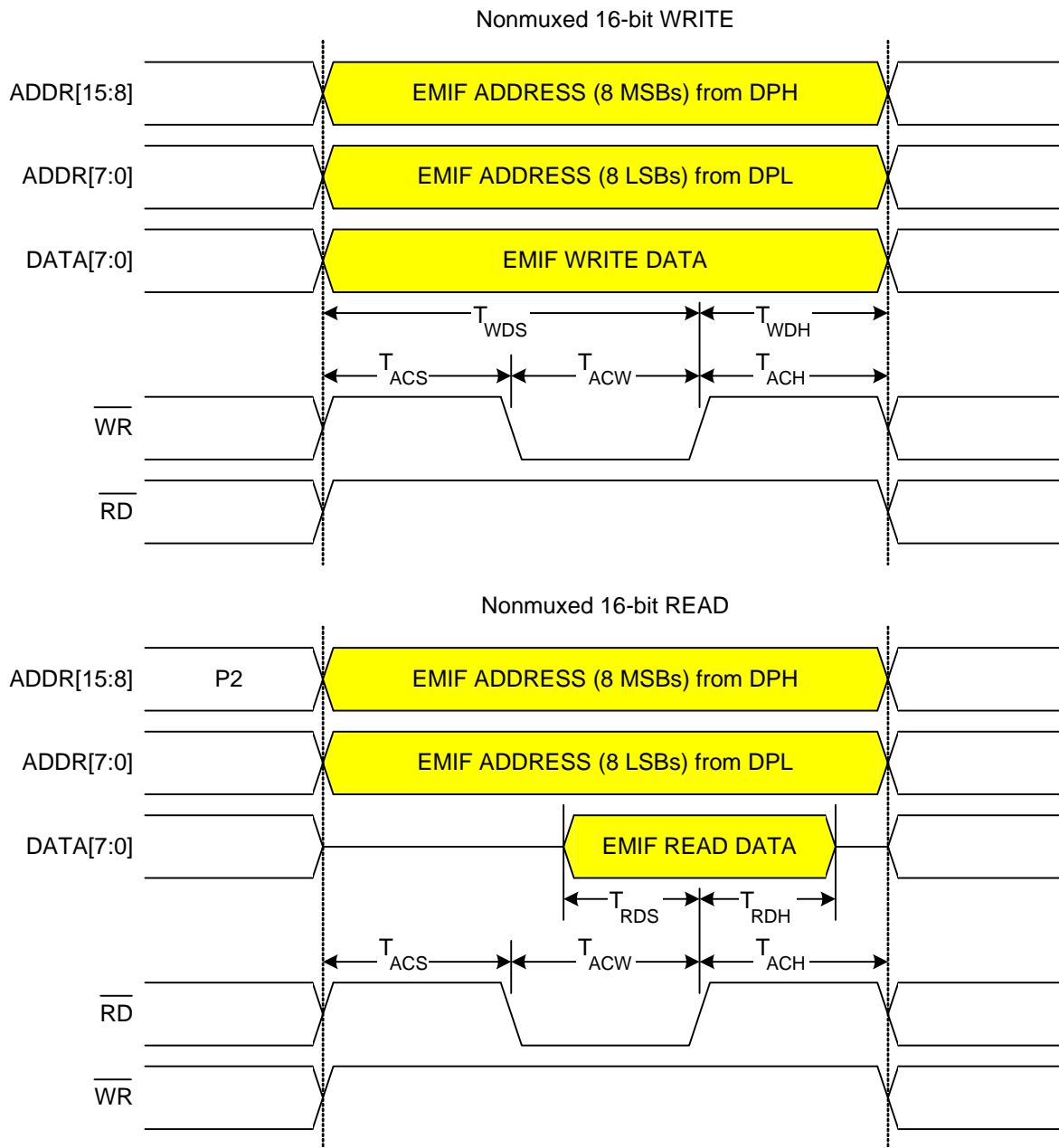

Figure 10.4. Non-Multiplexed 16-bit MOVX Timing

10.6.1.2. 8-bit MOVX without Bank Select: EMIOCF[4:2] = 101 or 111

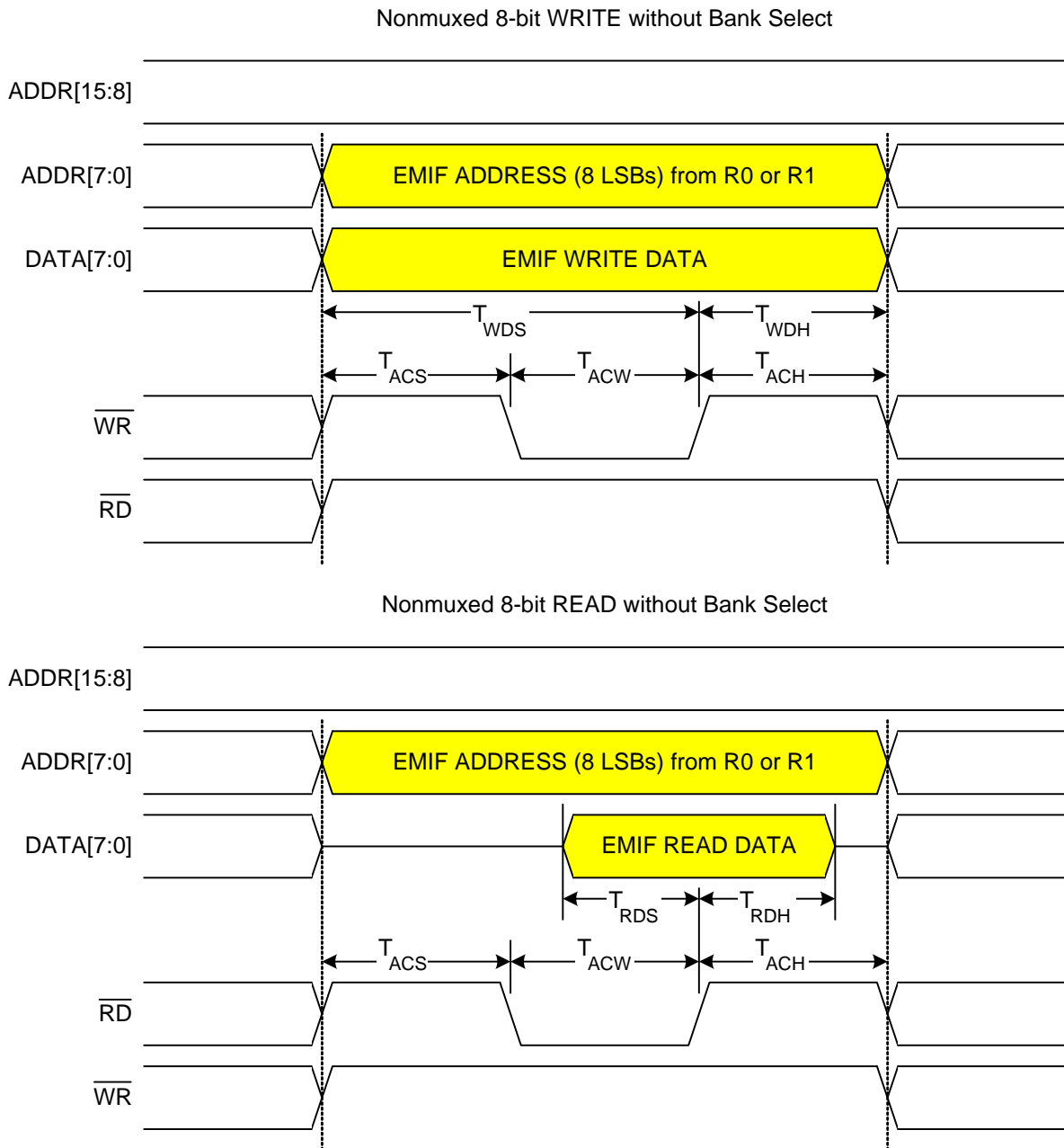

Figure 10.5. Non-Multiplexed 8-bit MOVX without Bank Select Timing

10.6.1.3. 8-bit MOVX with Bank Select: EMI0CF[4:2] = 110

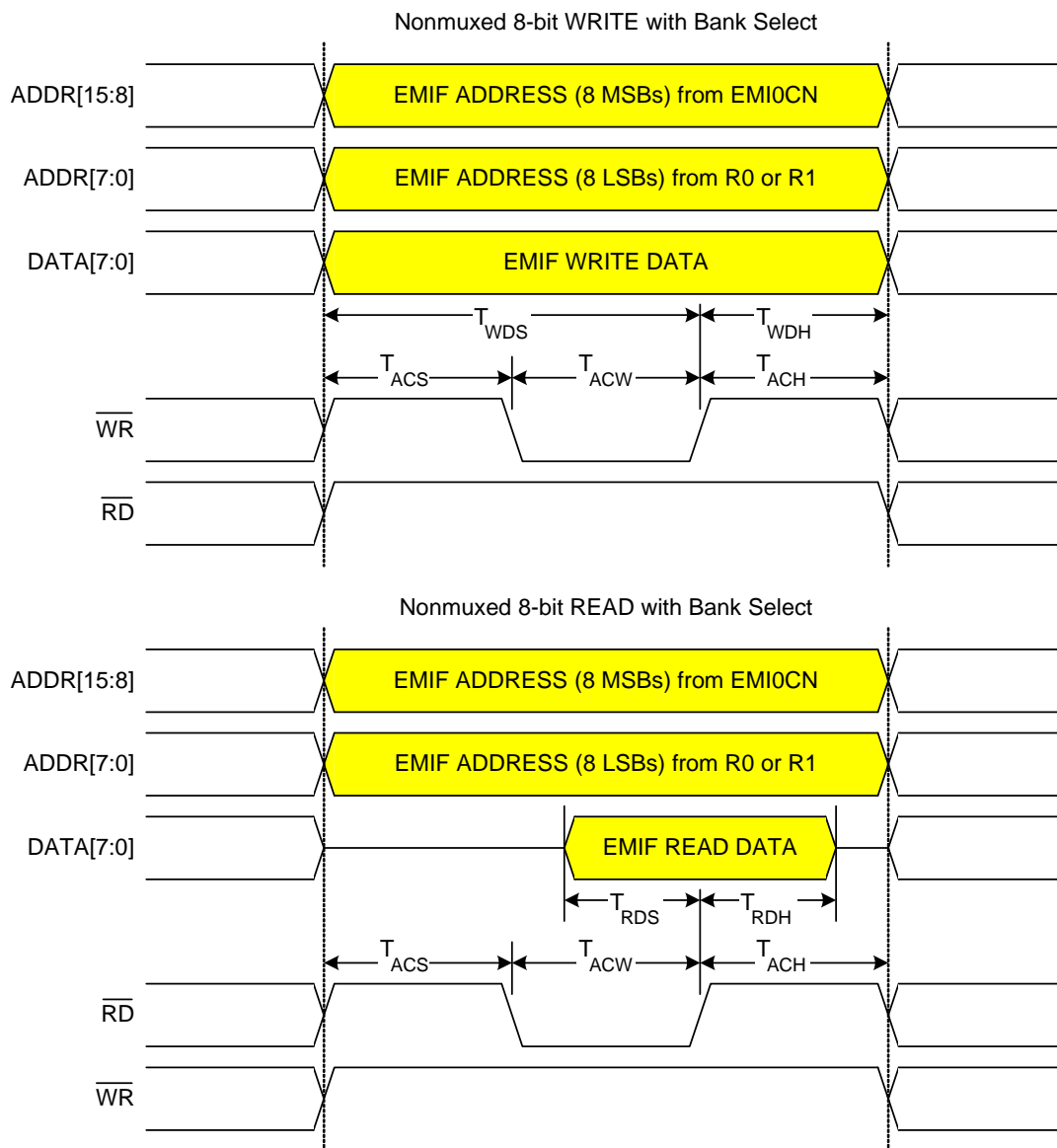

Figure 10.6. Non-Multiplexed 8-bit MOVX with Bank Select Timing

10.6.2. Multiplexed Mode

10.6.2.1. 16-bit MOVX: EMI0CF[4:2] = 001, 010, or 011

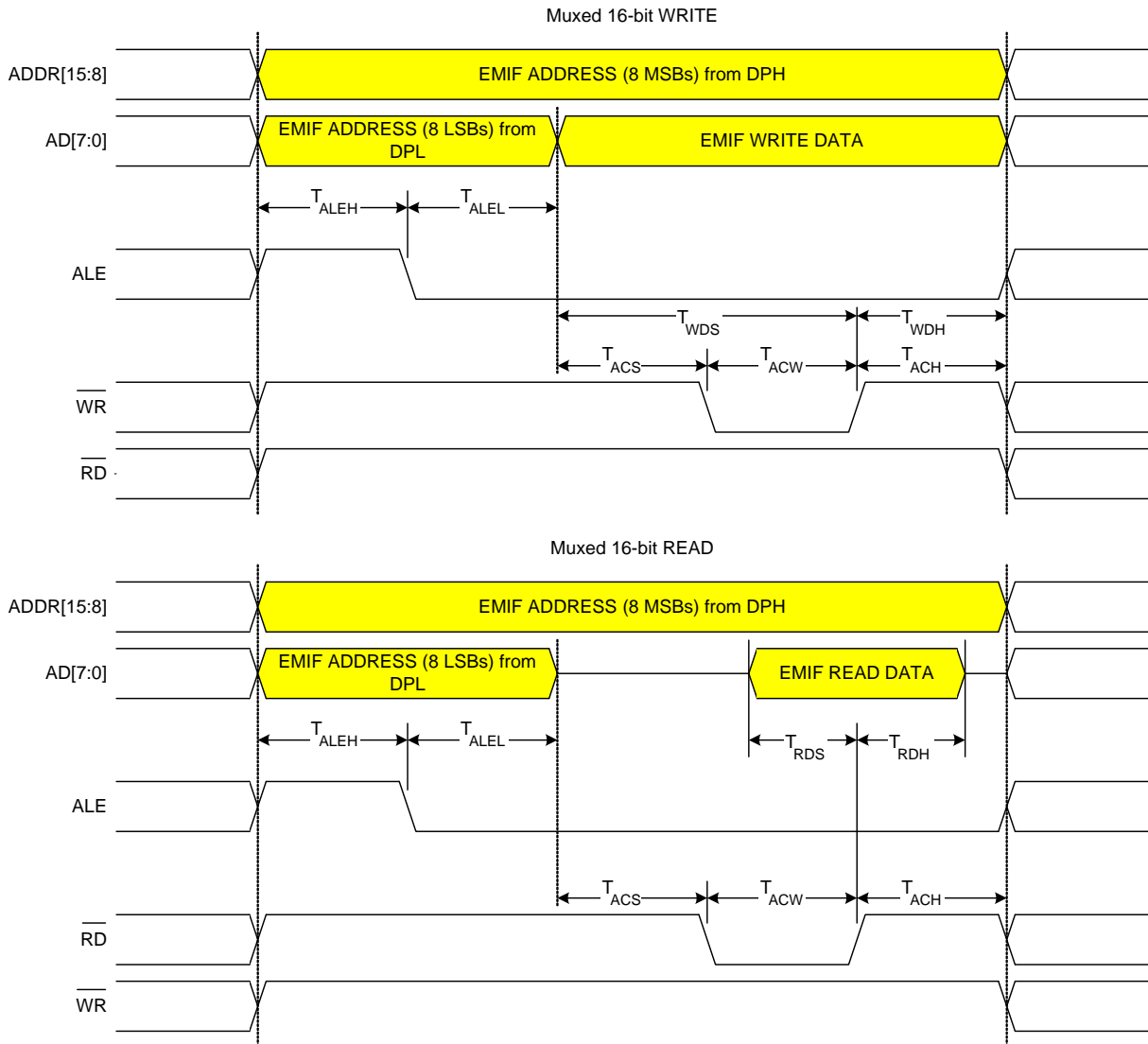

Figure 10.7. Multiplexed 16-bit MOVX Timing

10.6.2.2. 8-bit MOVX without Bank Select: EMI0CF[4:2] = 001 or 011

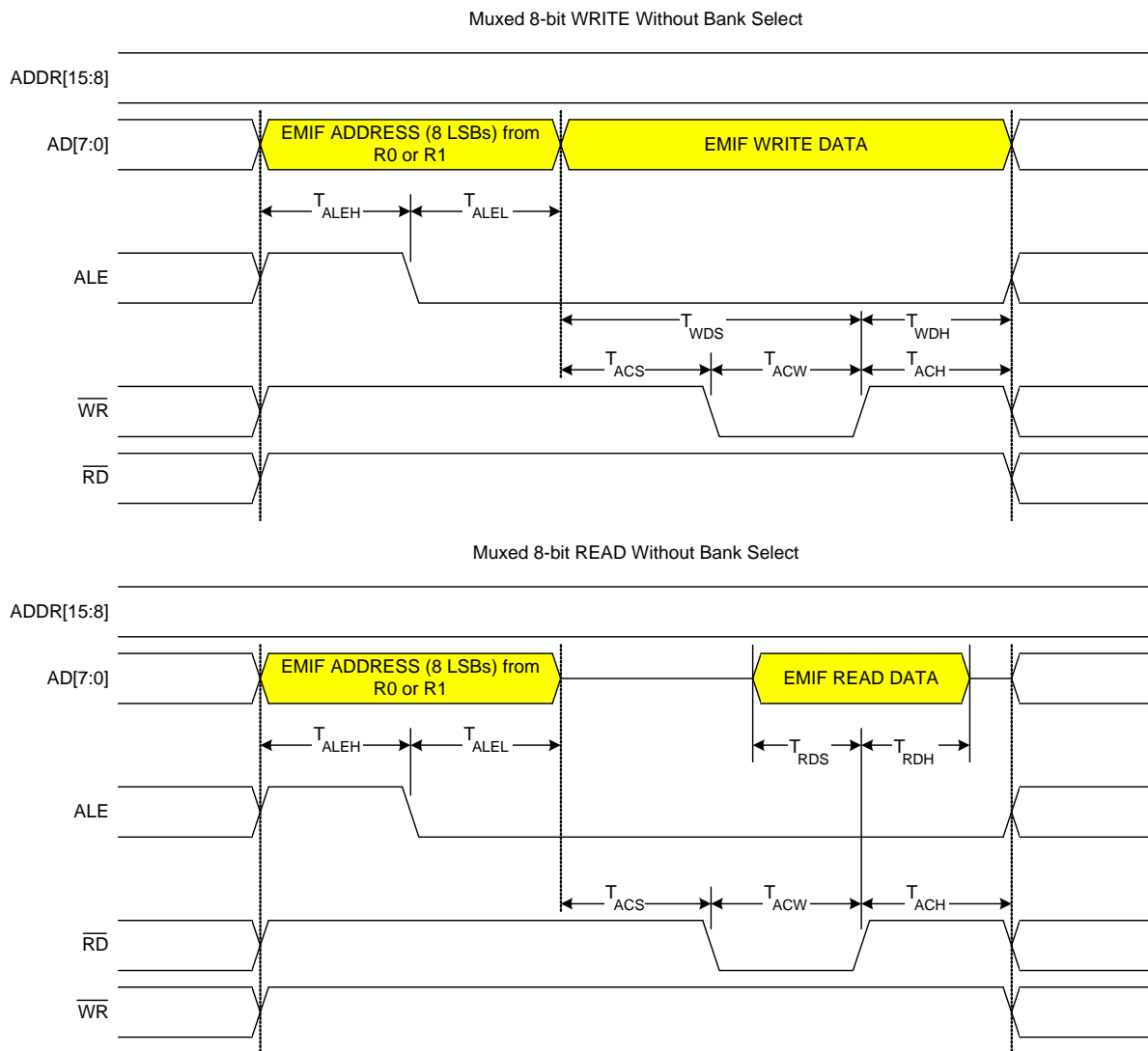

Figure 10.8. Multiplexed 8-bit MOVX without Bank Select Timing

10.6.2.3. 8-bit MOVX with Bank Select: EMI0CF[4:2] = 010

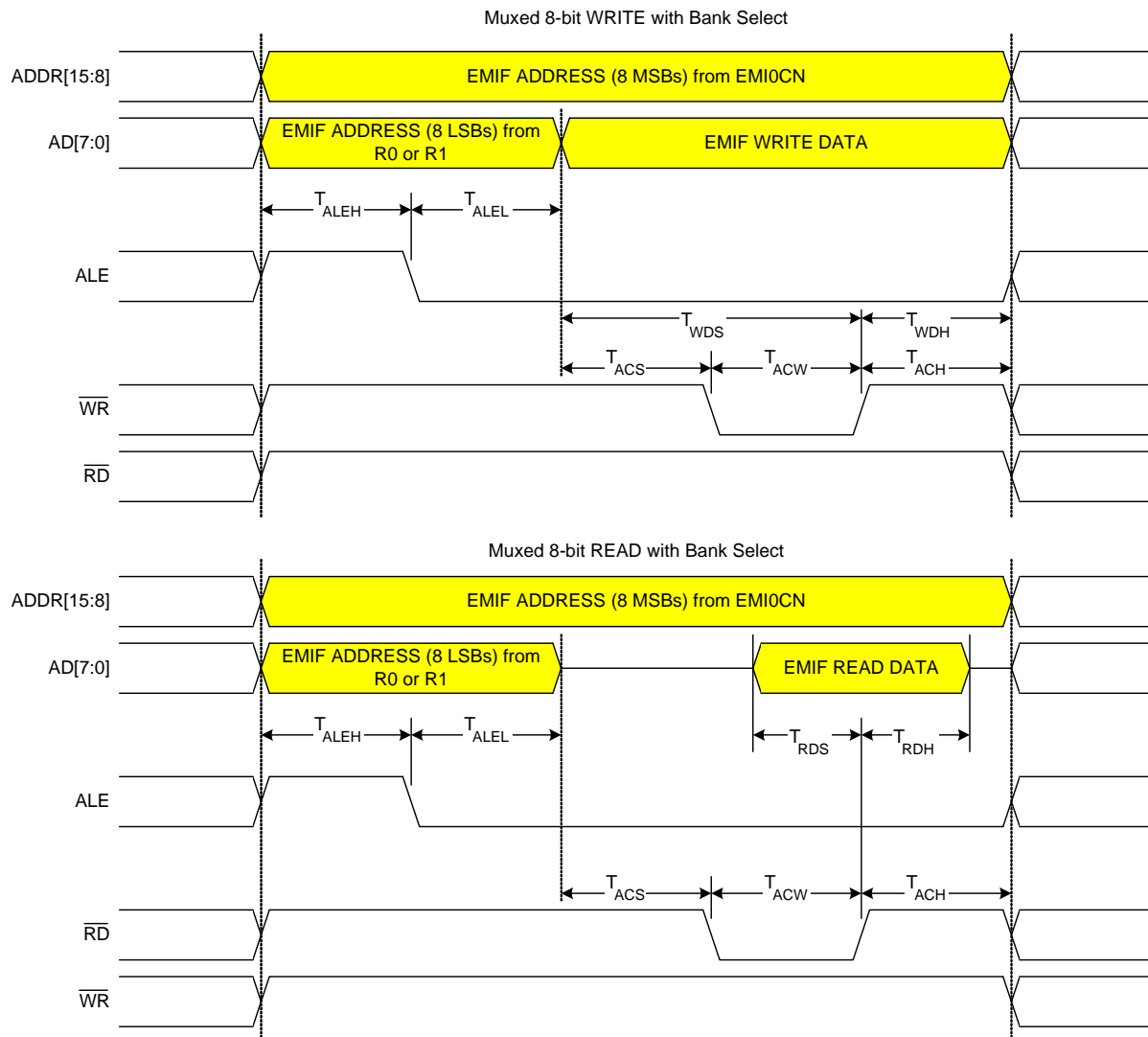

Figure 10.9. Multiplexed 8-bit MOVX with Bank Select Timing

Table 10.2. AC Parameters for External Memory Interface

Parameter	Description	Min*	Max*	Units
T_{ACS}	Address/Control Setup Time	0	$3 \times T_{SYSCLK}$	ns
T_{ACW}	Address/Control Pulse Width	$1 \times T_{SYSCLK}$	$16 \times T_{SYSCLK}$	ns
T_{ACH}	Address/Control Hold Time	0	$3 \times T_{SYSCLK}$	ns
T_{ALEH}	Address Latch Enable High Time	$1 \times T_{SYSCLK}$	$4 \times T_{SYSCLK}$	ns
T_{ALEL}	Address Latch Enable Low Time	$1 \times T_{SYSCLK}$	$4 \times T_{SYSCLK}$	ns
T_{WDS}	Write Data Setup Time	$1 \times T_{SYSCLK}$	$19 \times T_{SYSCLK}$	ns
T_{WDH}	Write Data Hold Time	0	$3 \times T_{SYSCLK}$	ns
T_{RDS}	Read Data Setup Time	20		ns
T_{RDH}	Read Data Hold Time	0		ns

***Note:** T_{SYSCLK} is equal to one period of the device system clock (SYSCLK).

11. Direct Memory Access (DMA0)

An on-chip direct memory access (DMA0) is included on the Si102x/3x devices. The DMA0 subsystem allows autonomous variable-length data transfers between XRAM and peripheral SFR registers without CPU intervention. During DMA0 operation, the CPU is free to perform some other tasks. In order to save total system power consumption, the CPU and flash can be powered down. DMA0 improves the system performance and efficiency with high data throughput peripherals.

DMA0 contains seven independent channels, common control registers, and a DMA0 Engine (see Figure 11.1). Each channel includes a register that assigns a peripheral to the channel, a channel control register, and a set of SFRs that include XRAM address information and SFR address information used by the channel during a data transfer. The DMA0 architecture is described in detail in Section 11.1.

The DMA0 in Si102x/3x devices supports four peripherals: AES0, ENC0, CRC1, and SPI1. Peripherals with DMA0 capability should be configured to work with the DMA0 through their own registers. The DMA0 provides up to seven channels, and each channel can be configured for one of nine possible data transfer functions:

- XRAM to ENC0L/M/H
- ENC0L/M/H sfrs to XRAM
- XRAM to CRC1IN sfr
- XRAM to SPI1DAT sfr
- SPI1DAT sfr to XRAM
- XRAM to AES0KIN sfr
- XRAM to AES0BIN sfr
- XRAM to AES0XIN sfr
- AES0YOUT sfr to XRAM

The DMA0 subsystem signals the MCU through a set of interrupt service routine flags. Interrupts can be generated when the DMA0 transfers half of the data length or full data length on any channel.

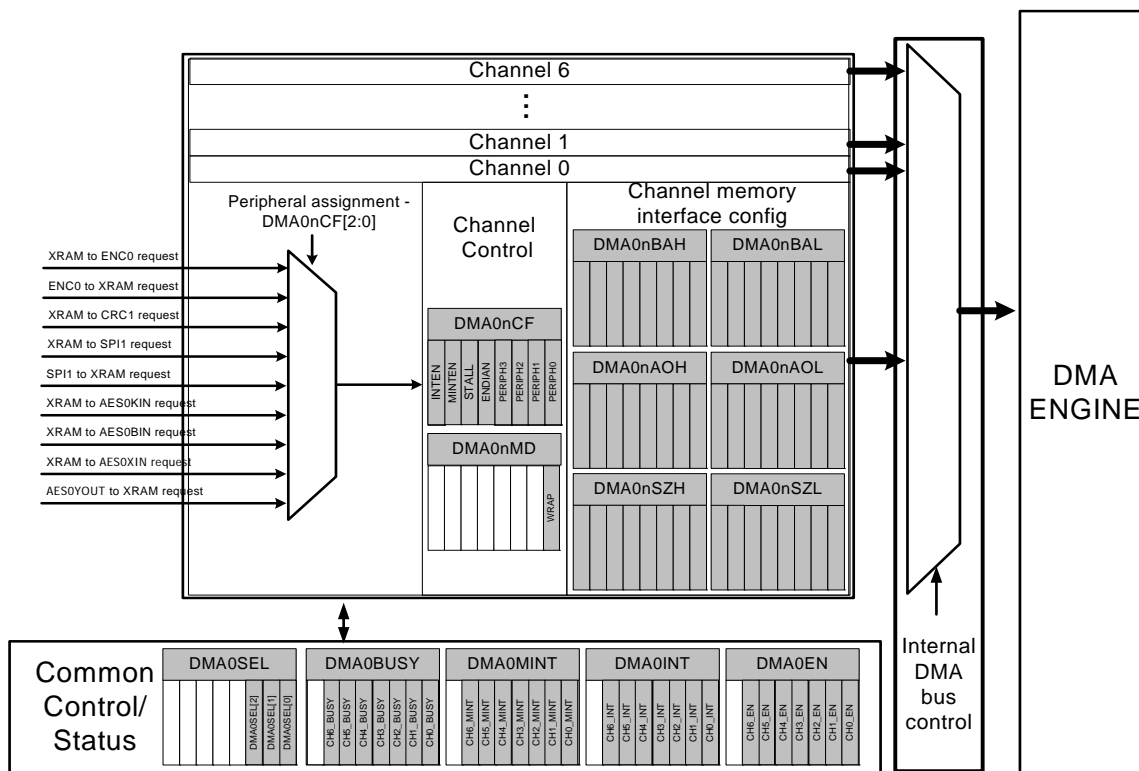

Figure 11.1. DMA0 Block Diagram

11.1. DMA0 Architecture

The first step in configuring a DMA0 channel is to select the desired channel for data transfer using DMA0SEL[2:0] bits (DMA0SEL). After setting the DMA0 channel, firmware can address channel-specific registers such as DMA0NCF, DMA0NBAH/L, DMA0NAOH/L, and DMA0NSZH/L. Once firmware selects a channel, the subsequent SFR configuration applies to the DMA0 transfer of that selected channel.

Each DMA0 channel consists of an SFR assigning the channel to a peripheral, a channel control register and a set of SFRs that describe XRAM and SFR addresses to be used during data transfer (See Figure 11.1). The peripheral assignment bits of DMA0nCF select one of the eight data transfer functions. The selected channel can choose the desired function by writing to the PERIPH[2:0] bits (DMA0NCF[2:0]).

The control register DMA0NCF of each channel configures the endian-ness of the data in XRAM, stall enable, full-length interrupt enable and mid-point interrupt enable. When a channel is stalled by setting the STALL bit (DMA0NCF.5), DMA0 transfers in progress will not be aborted, but new DMA0 transfers will be blocked until the stall status of the channel is reset. After the stall bit is set, software should poll the corresponding DMA0BUSY to verify that there are no more DMA transfers for that channel.

The memory interface configuration SFRs of a channel define the linear region of XRAM involved in the transfer through a 12-bit base address register DMA0NBAH:L, a 10-bit address offset register DMA0NAOH:L and a 10-bit data transfer size DMA0NSZH:L. The effective memory address is the address involved in the current DMA0 transaction.

$$\text{Effective Memory Address} = \text{Base Address} + \text{Address Offset}$$

The address offset serves as byte counter. The address offset should be always less than data transfer length. The address offset increments by one after each byte transferred. For DMA0 configuration of any channel, address offsets of active channels should be reset to 0 before DMA0 transfers occur.

Data transfer size DMA0NSZH:L defines the maximum number of bytes for the DMA0 transfer of the selected channel. If the address offset reaches data transfer size, the full-length interrupt flag bit CHn_INT (DMA0INT) of the selected channel will be asserted. Similarly, the mid-point interrupt flag bit CHn_MINT is set when the address offset is equal to half of data transfer size if the transfer size is an even number or when the address offset is equal to half of the transfer size plus one if the transfer size is an odd number. Interrupt flags must be cleared by software so that the next DMA0 data transfer can proceed.

The DMA0 subsystem permits data transfer between SFR registers and XRAM. The DMA0 subsystem executes its task based on settings of a channel's control and memory interface configuration SFRs. When data is copied from XRAM to SFR registers, it takes two cycles for DMA0 to read from XRAM and the SFR write occurs in the second cycle. If more than one byte is involved, a pipeline is used. When data is copied from SFR registers to XRAM, the DMA0 only requires one cycle for one byte transaction.

The selected DMA0 channel for a peripheral should be enabled through the enable bits CHn_EN (DMA0EN.n) to allow the DMA0 to transfer the data. When the DMA0 is transferring data on a channel, the busy status bit of the channel CHn_BUSY (DMA0BUSY.n) is set. During the transaction, writes to DMA0NSZH:L, DMA0NBAH:L, and DMA0NAOH:L are disabled.

Each peripheral is responsible for asserting the peripheral transfer requests necessary to service the particular peripheral. Some peripherals may have a complex state machine to manage the peripheral requests. Please refer to the DMA enabled peripheral chapters for additional information (AES0, CRC1, ENC0 and SPI1).

Besides reporting transaction status of a channel, DMA0BUSY can be used to force a DMA0 transfer on an already configured channel by setting the CHn_BUSY bit (DMA0BUSY.n).

The DMA0NMD SFR has a wrap bit that supports address offset wrapping. The size register DMA0NSZ sets the transfer size. Normally the address offset starts at zero and increases until it reaches size minus one. At this point the transfer is complete and the interrupt bit will be set. When the wrap bit is set, the address offset will automatically be reset to zero and transfers will continue as long as the peripheral keeps requesting data.

The wrap feature can be used to support key wrapping for the AES0 module. Normally the same key is used over and over with additional data blocks. So the wrap bit should be set when using the XRAM to AES0KIN request. This feature supports multiple-block encryption operations.

11.2. DMA0 Arbitration

11.2.1. DMA0 Memory Access Arbitration

If both DMA0 and CPU attempt to access SFR register or XRAM at the same time, the CPU pre-empts the DMA0 module. DMA0 will be stalled until CPU completes its bus activity.

11.2.2. DMA0 Channel Arbitration

Multiple DMA0 channels can request transfer simultaneously, but only one DMA0 channel will be granted the bus to transfer the data. Channel 0 has the highest priority. DMA0 channels are serviced based on their priority. A higher priority channel is serviced first. Channel arbitration occurs at the end of the data transfer granularity (transaction boundary) of the DMA. When there is a DMA0 request at the transaction boundary from higher priority channel, lower priority ones will be stalled until the highest priority one completes its transaction. So, for 16-bit transfers, the transaction boundary is at every 2 bytes.

11.3. DMA0 Operation in Low Power Modes

DMA0 remains functional in normal active, low power active, idle, low power idle modes but not in sleep or suspend mode. CPU will wait for DMA0 to complete all pending requests before it enters sleep mode. When the system wakes up from suspend or sleep mode to normal active mode, pending DMA0 interrupts will be serviced according to priority of channels. DMA0 stalls when CPU is in debug mode.

11.4. Transfer Configuration

The following steps are required to configure one of the DMA0 channels for operation:

1. Select the channel to be configured by writing DMA0SEL.
2. Specify the data transfer function by writing DMA0NCF. This register also specifies the endianness of the data in XRAM and enables full or mid-point interrupts.
3. Configure the wrapping mode by writing to DMA0NMD. Setting this bit will automatically reset the address offset after each completed transfer.
4. Specify the base address in XRAM for the transfer by writing DMA0NBAH:L.
5. Specify the size of the transfer in bytes by writing DMA0NSZH:L.
6. Reset the address offset counter by writing 0 to DMA0NAOH:L.
7. Enable the DMA0 channel by writing 1 to the appropriate bit in DMA0EN.

SFR Definition 11.1. DMA0EN: DMA0 Channel Enable

Bit	7	6	5	4	3	2	1	0
Name		CH6_EN	CH5_EN	CH4_EN	CH3_EN	CH2_EN	CH1_EN	CH0_EN
Type	R	R/W	R/W	R/W	R/W	R/W	R/W	R/W
Reset	0	0	0	0	0	0	0	0

SFR Page = 0x2; SFR Address = 0xD2

Bit	Name	Function
7	Unused	Read = 0b, Write = Don't Care
6	CH6_EN	Channel 6 Enable. 0: Disable DMA0 channel 6. 1: Enable DMA0 channel 6.
5	CH5_EN	Channel 5 Enable. 0: Disable DMA0 channel 5. 1: Enable DMA0 channel 5.
4	CH4_EN	Channel 4 Enable. 0: Disable DMA0 channel 4. 1: Enable DMA0 channel 4.
3	CH3_EN	Channel 3 Enable. 0: Disable DMA0 channel 3. 1: Enable DMA0 channel 3.
2	CH2_EN	Channel 2 Enable. 0: Disable DMA0 channel 2. 1: Enable DMA0 channel 2.
1	CH1_EN	Channel 1 Enable. 0: Disable DMA0 channel 1. 1: Enable DMA0 channel 1.
0	CH0_EN	Channel 0 Enable. 0: Disable DMA0 channel 0. 1: Enable DMA0 channel 0.

Si102x/3x

SFR Definition 11.2. DMA0INT: DMA0 Full-Length Interrupt

Bit	7	6	5	4	3	2	1	0
Name		CH6_INT	CH5_INT	CH4_INT	CH3_INT	CH2_INT	CH1_INT	CH0_INT
Type	R	R/W	R/W	R/W	R/W	R/W	R/W	R/W
Reset	0	0	0	0	0	0	0	0

SFR Page = 0x2; SFR Address = 0xD3

Bit	Name	Function
7	Unused	Read = 0b, Write = Don't Care
6	CH6_INT	Channel 6 Full-Length Interrupt Flag.¹ 0: Full-length interrupt has not occurred on channel 6. 1: Full-length interrupt has not occurred on channel 6.
5	CH5_INT	0: Full-length interrupt has not occurred on channel 5. 1: Full-length interrupt has not occurred on channel 5.
4	CH4_INT	Channel 4 Full-Length Interrupt Flag.¹ 0: Full-length interrupt has not occurred on channel 4. 1: Full-length interrupt has not occurred on channel 4.
3	CH3_INT	Channel 3 Full-Length Interrupt Flag.¹ 0: Full-length interrupt has not occurred on channel 3. 1: Full-length interrupt has not occurred on channel 3.
2	CH2_INT	Channel 2 Full-Length Interrupt Flag.¹ 0: Full-length interrupt has not occurred on channel 2. 1: Full-length interrupt has not occurred on channel 2.
1	CH1_INT	Channel 1 Full-Length Interrupt Flag.¹ 0: Full-length interrupt has not occurred on channel 1. 1: Full-length interrupt has not occurred on channel 1.
0	CH0_INT	Channel 0 Full-Length Interrupt Flag.¹ 0: Full-length interrupt has not occurred on channel 0. 1: Full-length interrupt has not occurred on channel 0.

Note: 1.Full-length interrupt flag is set when the offset address DMA0NAOH/L is equal to the data transfer size DMA0NSZH/L minus 1. This flag must be cleared by software or system reset. The full-length interrupt is enabled by setting bit 7 of DMA0NCF with DMA0SEL configured for the corresponding channel.

SFR Definition 11.3. DMA0MINT: DMA0 Mid-Point Interrupt

Bit	7	6	5	4	3	2	1	0
Name		CH6_MINT	CH5_MINT	CH4_MINT	CH3_MINT	CH2_MINT	CH1_MINT	CH0_MINT
Type	R	R/W	R/W	R/W	R/W	R/W	R/W	R/W
Reset	0	0	0	0	0	0	0	0

SFR Page = 0x2; SFR Address = 0xD4

Bit	Name	Function
7	Unused	Read = 0b, Write = Don't Care
6	CH6_MINT	Channel 6 Mid-Point Interrupt Flag. 0: Mid-Point interrupt has not occurred on channel 6. 1: Mid-Point interrupt has not occurred on channel 6.
5	CH5_MINT	Channel 5 Mid-Point Interrupt Flag. 0: Mid-Point interrupt has not occurred on channel 5. 1: Mid-Point interrupt has not occurred on channel 5.
4	CH4_MINT	Channel 4 Mid-Point Interrupt Flag. 0: Mid-Point interrupt has not occurred on channel 4. 1: Mid-Point interrupt has not occurred on channel 4.
3	CH3_MINT	Channel 3 Mid-Point Interrupt Flag. 0: Mid-Point interrupt has not occurred on channel 3. 1: Mid-Point interrupt has not occurred on channel 3.
2	CH2_MINT	Channel 2 Mid-Point Interrupt Flag. 0: Mid-Point interrupt has not occurred on channel 2. 1: Mid-Point interrupt has not occurred on channel 2.
1	CH1_MINT	Channel 1 Mid-Point Interrupt Flag. 0: Mid-Point interrupt has not occurred on channel 1. 1: Mid-Point interrupt has not occurred on channel 1.
0	CH0_MINT	Channel 0 Mid-Point Interrupt Flag. 0: Mid-Point interrupt has not occurred on channel 0. 1: Mid-Point interrupt has not occurred on channel 0.

Note: Mid-point Interrupt flag is set when the offset address DMA0NAOH/L is equal to half of the data transfer size DMA0NSZH/L if the transfer size is an even number or half of data transfer size DMA0NSZH/L plus one if the transfer size is an odd number. This flag must be cleared by software or system reset. The mid-point interrupt is enabled by setting bit 6 of DMA0NCF with DMA0SEL configured for the corresponding channel.

Si102x/3x

SFR Definition 11.4. DMA0BUSY: DMA0 Busy

Bit	7	6	5	4	3	2	1	0
Name		CH6_BUSY	CH5_BUSY	CH4_BUSY	CH3_BUSY	CH2_BUSY	CH1_BUSY	CH0_BUSY
Type	R	R/W	R/W	R/W	R/W	R/W	R/W	R/W
Reset	0	0	0	0	0	0	0	0

SFR Page = 0x2; SFR Address = 0xD5

Bit	Name	Description	Write	Read
7	Unused		No effect.	Always Reads 0.
6	CH6_BUSY	Channel 6 Busy.	0: No effect. 1: Force DMA0 transfer to start on channel 6.	0: DMA0 channel 6 Idle. 1: DMA0 transfer in progress on channel 6.
5	CH5_BUSY	Channel 5 Busy.	0: No effect. 1: Force DMA0 transfer to start on channel 5.	0: DMA0 channel 5 Idle. 1: DMA0 transfer in progress on channel 5.
4	CH4_BUSY	Channel 4 Busy.	0: No effect. 1: Force DMA0 transfer to start on channel 4.	0: DMA0 channel 4 Idle. 1: DMA0 transfer in progress on channel 4.
3	CH3_BUSY	Channel 3 Busy.	0: No effect. 1: Force DMA0 transfer to start on channel 3.	0: DMA0 channel 3 Idle. 1: DMA0 transfer in progress on channel 3.
2	CH2_BUSY	Channel 2 Busy.	0: No effect. 1: Force DMA0 transfer to start on channel 2.	0: DMA0 channel 2 Idle. 1: DMA0 transfer in progress on channel 2.
1	CH1_BUSY	Channel 1 Busy.	0: No effect. 1: Force DMA0 transfer to start on channel 1.	0: DMA0 channel 1 Idle. 1: DMA0 transfer in progress on channel 1.
0	CH0_BUSY	Channel 0 Busy.	0: No effect. 1: Force DMA0 transfer to start on channel 0.	0: DMA0 channel 0 Idle. 1: DMA0 transfer in progress on channel 0.

SFR Definition 11.5. DMA0SEL: DMA0 Channel Select for Configuration

Bit	7	6	5	4	3	2	1	0
Name						DMA0SEL[2:0]		
Type	R	R/W	R/W	R/W	R/W	R/W		
Reset	0	0	0	0	0	0	0	0

SFR Page = 0x2; SFR Address = 0xD1

Bit	Name	Function
7:3	Unused	Read = 0b, Write = Don't Care
2:0	DMA0SEL[2:0]	<p>Channel Select for Configuration.</p> <p>These bits select the channel for configuration of the DMA0 transfer. The first step to configure a channel for DMA0 transfer is to select the desired channel, and then write to channel specific registers DMA0NCF, DMA0NBAL/H, DMA0NAOL/H, DMA0NSZL/H.</p> <p>000: Select channel 0 001: Select channel 1 010: Select channel 2 011: Select channel 3 100: Select channel 4 101: Select channel 5 110: Select channel 6 111: Invalid</p>

SFR Definition 11.6. DMA0NMD: DMA Channel Mode

Bit	7	6	5	4	3	2	1	0
Name								WRAP
Type	R/W	R/W	R/W	R/W	R/W	R/W	R/W	R/W
Reset	0	0	0	0	0	0	0	0

SFR Page = 0x2; SFR Address = 0xD6

Bit	Name	Function
7:1	reserved	Read = 0, Write = 0
0	WRAP	Wrap Enable. Setting this bit will enable wrapping. The DMA0NSZ register sets the transfer size. Normally the DMA0AO value starts at zero in increases to the DMANSZ minus one. At this point the transfer is complete and the interrupt bit will be set. If the WRAP bit is set, the DMA0NAO will be reset to zero.

Note: This is a DMA channel indirect register. Select the desired channel first writing the DMA0SEL register.

SFR Definition 11.7. DMA0NCF: DMA Channel Configuration

Bit	7	6	5	4	3	2	1	0
Name	INTEN	MINTEN	STALL	ENDIAN	PERIPH[3:0]			
Type	R/W	R/W	R/W	R/W	R	R/W		
Reset	0	0	0	0	0	0	0	0

SFR Page = 0x2; SFR Address = 0xC9

Bit	Name	Function
7	INTEN	Full-Length Interrupt Enable. 0: Disable the full-length interrupt of the selected channel. 1: Enable the full-length interrupt of the selected channel.
6	MINTEN	Mid-Point Interrupt Enable. 0: Disable the mid-point interrupt of the selected channel. 1: Enable the mid-point interrupt of the selected channel.
5	STALL	DMA0 Stall. Setting this bit stalls the DMA0 transfer on the selected channel. After a Stall, this bit must be cleared by software to resume normal operation. 0: The DMA0 transfer of the selected channel is not being stalled. 1: The DMA0 transfer of the selected channel is stalled.
4	ENDIAN	Data Transfer Endianness. This bit sets the byte order for multi-byte transfers. This is only relevant for two or three byte transfers. The value of this bit does not matter for single byte transfers. 0: Little Endian 1: Big Endian
3:0	PERIPH[2:0]	Peripheral Selection of The Selected Channel. These bits choose one of the nine DMA0 transfer functions for the selected channel. 0000: XRAM to ENC0L/M/H 0001: ENC0L/M/H to XRAM 0010: XRAM to CRC1IN 0011: XRAM to SPI1DAT 0100: SPI1DAT sfr to XRAM 0101: XRAM to AES0KIN 0110: XRAM to AES0BIN 0111: XRAM to AES0XIN 1000: AES0YOUTto XRAM
Note: This is a DMA channel indirect register. Select the desired channel first writing the DMA0SEL register.		

SFR Definition 11.8. DMA0NBAH: Memory Base Address High Byte

Bit	7	6	5	4	3	2	1	0
Name	NBAH[3:0]							
Type	R	R	R	R	R/W			
Reset	0	0	0	0	0	0	0	0

SFR Page = 0x2; SFR Address = 0xCB

Bit	Name	Function
7:4	Unused	Read = 0b, Write = Don't Care
3:0	NBAH[3:0]	Memory Base Address High Byte. Sets high byte of the memory base address which is the DMA0 XRAM starting address of the selected channel if the channel's address offset DMA0NAO is reset to 0.
Note: This is a DMA channel indirect register. Select the desired channel first writing the DMA0SEL register.		

SFR Definition 11.9. DMA0NBAL: Memory Base Address Low Byte

Bit	7	6	5	4	3	2	1	0
Name	NBAH[7:0]							
Type	R/W							
Reset	0	0	0	0	0	0	0	0

SFR Page = 0x2; SFR Address = 0xCA

Bit	Name	Function
7:0	NBAL[7:0]	Memory Base Address Low Byte. Sets low byte of the memory base address which is the DMA0 XRAM starting address of the selected channel if the channel's address offset DMA0NAO is reset to 0.
Note: This is a DMA channel indirect register. Select the desired channel first writing the DMA0SEL register.		

SFR Definition 11.10. DMA0NAOH: Memory Address Offset High Byte

Bit	7	6	5	4	3	2	1	0
Name	NAOH[1:0]							
Type	R	R	R	R	R	R	R/W	
Reset	0	0	0	0	0	0	0	0

SFR Page = 0x2; SFR Address = 0xCD

Bit	Name	Function
7:2	Unused	Read = 0b, Write = Don't Care
1:0	NAOH[1:0]	Memory Address Offset High Byte. Sets the high byte of the address offset of the selected channel which acts a counter during DMA0 transfer. The address offset auto-increments by one after one byte is transferred. When configuring a channel for DMA0 transfer, the address offset should be reset to 0.
Note: This is a DMA channel indirect register. Select the desired channel first writing the DMA0SEL register.		

SFR Definition 11.11. DMA0NAOL: Memory Address Offset Low Byte

Bit	7	6	5	4	3	2	1	0
Name	NAOL[7:0]							
Type	R/W							
Reset	0	0	0	0	0	0	0	0

SFR Page = 0x2; SFR Address = 0xCC

Bit	Name	Function
7:0	NAOL[7:0]	Memory Address Offset Low Byte. Sets the low byte of the address offset of the selected channel which acts a counter during DMA0 transfer. The address offset auto-increments by one after one byte is transferred. When configuring a channel for DMA0 transfer, the address offset should be reset to 0.
Note: This is a DMA channel indirect register. Select the desired channel first writing the DMA0SEL register.		

Si102x/3x

SFR Definition 11.12. DMA0NSZH: Transfer Size High Byte

Bit	7	6	5	4	3	2	1	0
Name							NSZH[1:0]	
Type	R	R	R	R	R	R	R/W	
Reset	0	0	0	0	0	0	0	0

SFR Page = 0x2; SFR Address = 0xCF

Bit	Name	Function
7:2	Unused	Read = 0b, Write = Don't Care
1:0	NSZH[1:0]	Transfer Size High Byte. Sets high byte of DMA0 transfer size of the selected channel. Transfer size sets the maximum number of bytes for the DMA0 transfer. When the address offset is equal to the transfer size, a full-length interrupt is generated on the channel.

Note: This is a DMA channel indirect register. Select the desired channel first writing the DMA0SEL register.

SFR Definition 11.13. DMA0NSZL: Memory Transfer Size Low Byte

Bit	7	6	5	4	3	2	1	0
Name	NSZL[7:0]							
Type	R/W							
Reset	0	0	0	0	0	0	0	0

SFR Page = 0x2; SFR Address = 0xCE

Bit	Name	Function
7:0	NSZL[7:0]	Memory Transfer Size Low Byte. Sets low byte of DMA0 transfer size of the selected channel. Transfer size sets the maximum number of bytes for the DMA0 transfer. When the address offset is equal to the transfer size, a full-length interrupt is generated on the channel.

Note: This is a DMA channel indirect register. Select the desired channel first writing the DMA0SEL register.

12. Cyclic Redundancy Check Unit (CRC0)

Si102x/3x devices include a cyclic redundancy check unit (CRC0) that can perform a CRC using a 16-bit or 32-bit polynomial. CRC0 accepts a stream of 8-bit data written to the CRC0IN register. CRC0 posts the 16-bit or 32-bit result to an internal register. The internal result register may be accessed indirectly using the CRC0PNT bits and CRC0DAT register, as shown in Figure 12.1. CRC0 also has a bit reverse register for quick data manipulation.

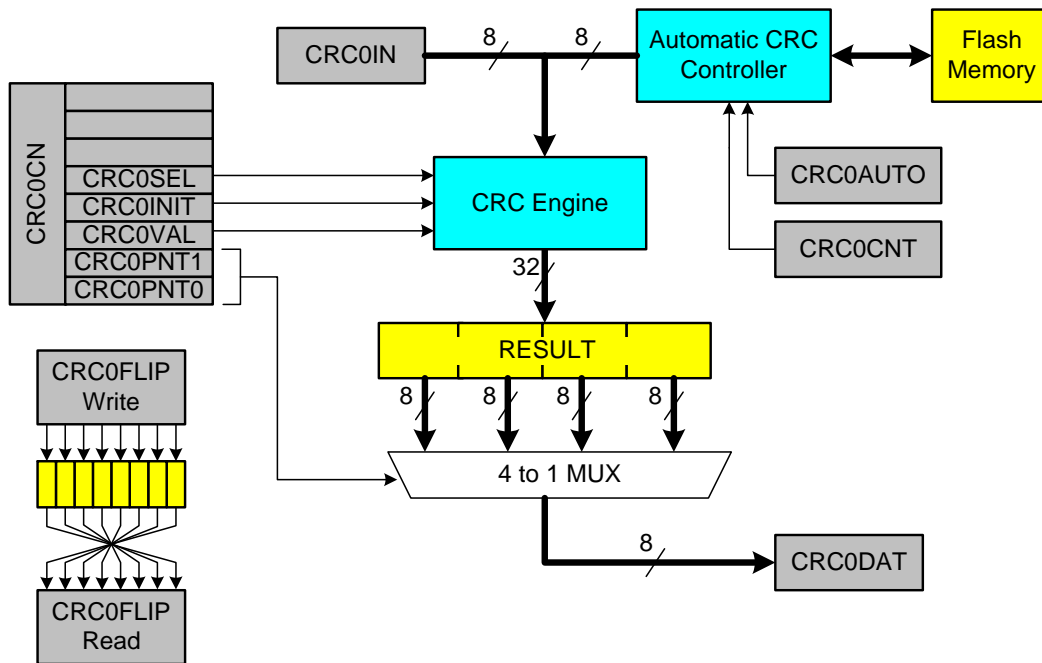

Figure 12.1. CRC0 Block Diagram

12.1. 16-bit CRC Algorithm

The CRC0 unit calculates the 16-bit CRC MSB-first, using a polynomial of 0x1021. The following describes the 16-bit CRC algorithm performed by the hardware:

1. XOR the most-significant byte of the current CRC result with the input byte. If this is the first iteration of the CRC unit, the current CRC result will be the set initial value (0x0000 or 0xFFFF).
 - a. If the MSB of the CRC result is set, left-shift the CRC result, and then XOR the CRC result with the polynomial (0x1021).
 - b. If the MSB of the CRC result is not set, left-shift the CRC result.
2. Repeat at Step 2a for the number of input bits (8).

Si102x/3x

The 16-bit Si102x/3x CRC algorithm can be described by the following code:

```
unsigned short UpdateCRC (unsigned short CRC_acc, unsigned char CRC_input)
{
    unsigned char i;                // loop counter

    #define POLY 0x1021

    // Create the CRC "dividend" for polynomial arithmetic (binary arithmetic
    // with no carries)
    CRC_acc = CRC_acc ^ (CRC_input << 8);

    // "Divide" the poly into the dividend using CRC XOR subtraction
    // CRC_acc holds the "remainder" of each divide
    //
    // Only complete this division for 8 bits since input is 1 byte
    for (i = 0; i < 8; i++)
    {
        // Check if the MSB is set (if MSB is 1, then the POLY can "divide"
        // into the "dividend")
        if ((CRC_acc & 0x8000) == 0x8000)
        {
            // if so, shift the CRC value, and XOR "subtract" the poly
            CRC_acc = CRC_acc << 1;
            CRC_acc ^= POLY;
        }
        else
        {
            // if not, just shift the CRC value
            CRC_acc = CRC_acc << 1;
        }
    }

    // Return the final remainder (CRC value)
    return CRC_acc;
}
```

The following table lists several input values and the associated outputs using the 16-bit CRC algorithm:

Table 12.1. Example 16-bit CRC Outputs

Input	Output
0x63	0xBD35
0x8C	0xB1F4
0x7D	0x4ECA
0xAA, 0xBB, 0xCC	0x6CF6
0x00, 0x00, 0xAA, 0xBB, 0xCC	0xB166

12.2. 32-bit CRC Algorithm

The CRC0 unit calculates the 32-bit CRC using a polynomial of 0x04C11DB7. The CRC-32 algorithm is reflected, meaning that all of the input bytes and the final 32-bit output are bit-reversed in the processing engine. The following is a description of a simplified CRC algorithm that produces results identical to the hardware:

- Step 1. XOR the least-significant byte of the current CRC result with the input byte. If this is the first iteration of the CRC unit, the current CRC result will be the set initial value (0x00000000 or 0xFFFFFFFF).
- Step 2. Right-shift the CRC result.
- Step 3. If the LSB of the CRC result is set, XOR the CRC result with the reflected polynomial (0xEDB88320).
- Step 4. Repeat at Step 2 for the number of input bits (8).

For example, the 32-bit CRC algorithm can be described by the following code:

```
unsigned long UpdateCRC (unsigned long CRC_acc, unsigned char CRC_input)
{
    unsigned char i; // loop counter
    #define POLY 0xEDB88320 // bit-reversed version of the poly 0x04C11DB7
    // Create the CRC "dividend" for polynomial arithmetic (binary arithmetic
    // with no carries)

    CRC_acc = CRC_acc ^ CRC_input;

    // "Divide" the poly into the dividend using CRC XOR subtraction
    // CRC_acc holds the "remainder" of each divide
    //
    // Only complete this division for 8 bits since input is 1 byte
    for (i = 0; i < 8; i++)
    {
        // Check if the MSB is set (if MSB is 1, then the POLY can "divide"
        // into the "dividend")
        if ((CRC_acc & 0x00000001) == 0x00000001)
        {
            // if so, shift the CRC value, and XOR "subtract" the poly
            CRC_acc = CRC_acc >> 1;
            CRC_acc ^= POLY;
        }
        else
        {
            // if not, just shift the CRC value
            CRC_acc = CRC_acc >> 1;
        }
    }
    // Return the final remainder (CRC value)
    return CRC_acc;
}
```

The following table lists several input values and the associated outputs using the 32-bit CRC algorithm (an initial value of 0xFFFFFFFF is used):

Table 12.2. Example 32-bit CRC Outputs

Input	Output
0x63	0xF9462090
0xAA, 0xBB, 0xCC	0x41B207B3
0x00, 0x00, 0xAA, 0xBB, 0xCC	0x78D129BC

12.3. Preparing for a CRC Calculation

To prepare CRC0 for a CRC calculation, software should select the desired polynomial and set the initial value of the result. Two polynomials are available: 0x1021 (16-bit) and 0x04C11DB7 (32-bit). The CRC0 result may be initialized to one of two values: 0x00000000 or 0xFFFFFFFF. The following steps can be used to initialize CRC0.

1. Select a polynomial (Set CRC0SEL to 0 for 32-bit or 1 for 16-bit).
2. Select the initial result value (Set CRC0VAL to 0 for 0x00000000 or 1 for 0xFFFFFFFF).
3. Set the result to its initial value (Write 1 to CRC0INIT).

12.4. Performing a CRC Calculation

Once CRC0 is initialized, the input data stream is sequentially written to CRC0IN, one byte at a time. The CRC0 result is automatically updated after each byte is written. The CRC engine may also be configured to automatically perform a CRC on one or more flash sectors. The following steps can be used to automatically perform a CRC on flash memory.

1. Prepare CRC0 for a CRC calculation as shown above.
2. If necessary, set the IFBANK bits in the PSBANK for the desired code bank.
3. Write the index of the starting page to CRC0AUTO.
4. Set the AUTOEN bit in CRC0AUTO.
5. Write the number of flash sectors to perform in the CRC calculation to CRC0CNT.
Note: Each flash sector is 1024 bytes.
6. Write any value to CRC0CN (or OR its contents with 0x00) to initiate the CRC calculation. The CPU will not execute code any additional code until the CRC operation completes.
7. Clear the AUTOEN bit in CRC0AUTO.
8. Read the CRC result using the procedure below.

Setting the IFBANK bits in the PSBANK SFR is only necessary when accessing the upper banks on 128 kB code bank devices (Si1020/24/30/34). Multiple CRCs are required to cover the entire 128 kB Flash array. When writing to the PSBANK SFR, the code initiating the auto CRC of flash must be executing from the common area.

12.5. Accessing the CRC0 Result

The internal CRC0 result is 32-bits (CRC0SEL = 0b) or 16-bits (CRC0SEL = 1b). The CRC0PNT bits select the byte that is targeted by read and write operations on CRC0DAT and increment after each read or write. The calculation result will remain in the internal CR0 result register until it is set, overwritten, or additional data is written to CRC0IN.

SFR Definition 12.1. CRC0CN: CRC0 Control

Bit	7	6	5	4	3	2	1	0
Name				CRC0SEL	CRC0INIT	CRC0VAL	CRC0PNT[1:0]	
Type	R/W	R/W	R/W	R/W	R/W	R/W	R/W	
Reset	0	0	0	0	0	0	0	0

SFR Page = 0xF; SFR Address = 0x92

Bit	Name	Function
7:5	Unused	Read = 000b; Write = Don't Care.
4	CRC0SEL	CRC0 Polynomial Select Bit. This bit selects the CRC0 polynomial and result length (32-bit or 16-bit). 0: CRC0 uses the 32-bit polynomial 0x04C11DB7 for calculating the CRC result. 1: CRC0 uses the 16-bit polynomial 0x1021 for calculating the CRC result.
3	CRC0INIT	CRC0 Result Initialization Bit. Writing a 1 to this bit initializes the entire CRC result based on CRC0VAL.
2	CRC0VAL	CRC0 Set Value Initialization Bit. This bit selects the set value of the CRC result. 0: CRC result is set to 0x00000000 on write of 1 to CRC0INIT. 1: CRC result is set to 0xFFFFFFFF on write of 1 to CRC0INIT.
1:0	CRC0PNT[1:0]	CRC0 Result Pointer. Specifies the byte of the CRC result to be read/written on the next access to CRC0DAT. The value of these bits will auto-increment upon each read or write. For CRC0SEL = 0: 00: CRC0DAT accesses bits 7–0 of the 32-bit CRC result. 01: CRC0DAT accesses bits 15–8 of the 32-bit CRC result. 10: CRC0DAT accesses bits 23–16 of the 32-bit CRC result. 11: CRC0DAT accesses bits 31–24 of the 32-bit CRC result. For CRC0SEL = 1: 00: CRC0DAT accesses bits 7–0 of the 16-bit CRC result. 01: CRC0DAT accesses bits 15–8 of the 16-bit CRC result. 10: CRC0DAT accesses bits 7–0 of the 16-bit CRC result. 11: CRC0DAT accesses bits 15–8 of the 16-bit CRC result.

Si102x/3x

SFR Definition 12.2. CRC0IN: CRC0 Data Input

Bit	7	6	5	4	3	2	1	0
Name	CRC0IN[7:0]							
Type	R/W							
Reset	0	0	0	0	0	0	0	0

SFR Page = 0xF; SFR Address = 0x93

Bit	Name	Function
7:0	CRC0IN[7:0]	CRC0 Data Input. Each write to CRC0IN results in the written data being computed into the existing CRC result according to the CRC algorithm described in Section 12.1

SFR Definition 12.3. CRC0DAT: CRC0 Data Output

Bit	7	6	5	4	3	2	1	0
Name	CRC0DAT[7:0]							
Type	R/W							
Reset	0	0	0	0	0	0	0	0

SFR Page = 0xF; SFR Address = 0x91

Bit	Name	Function
7:0	CRC0DAT[7:0]	CRC0 Data Output. Each read or write performed on CRC0DAT targets the CRC result bits pointed to by the CRC0 Result Pointer (CRC0PNT bits in CRC0CN).

SFR Definition 12.4. CRC0AUTO: CRC0 Automatic Control

Bit	7	6	5	4	3	2	1	0
Name	AUTOEN	CRCDONE	CRC0ST[5:0]					
Type	R/W							R/W
Reset	0	1	0	0	0	0	0	0

SFR Page = 0xF; SFR Address = 0x96

Bit	Name	Function
7	AUTOEN	Automatic CRC Calculation Enable. When AUTOEN is set to 1, any write to CRC0CN will initiate an automatic CRC starting at flash sector CRC0ST and continuing for CRC0CNT sectors.
6	CRCDONE	CRCDONE Automatic CRC Calculation Complete. Set to 0 when a CRC calculation is in progress. Note that code execution is stopped during a CRC calculation, therefore reads from firmware will always return 1.
5:0	CRC0ST[5:0]	Automatic CRC Calculation Starting Flash Sector. These bits specify the flash sector to start the automatic CRC calculation. The starting address of the first flash sector included in the automatic CRC calculation is CRC0ST x 1024. For 128 kB devices, pages 32–63 access the upper code bank as selected by the IFBANK bits in the PSBANK SFR.

SFR Definition 12.5. CRC0CNT: CRC0 Automatic Flash Sector Count

Bit	7	6	5	4	3	2	1	0
Name	CRC0CNT[5:0]							
Type	R/W							R/W
Reset	0	0	0	0	0	0	0	0

SFR Page = 0xF; SFR Address = 0x97

Bit	Name	Function
7:6	Unused	Read = 00b; Write = Don't Care.
5:0	CRC0CNT[5:0]	Automatic CRC Calculation Flash Sector Count. These bits specify the number of flash sectors to include in an automatic CRC calculation. The starting address of the last flash sector included in the automatic CRC calculation is (CRC0ST+CRC0CNT) x 1024. The last page should not exceed page 63. Setting both CRC0ST and CRC0CNT to 0 will perform a CRC over the 64kB banked memory space.

12.6. CRC0 Bit Reverse Feature

CRC0 includes hardware to reverse the bit order of each bit in a byte as shown in Figure 12.2. Each byte of data written to CRC0FLIP is read back bit reversed. For example, if 0xC0 is written to CRC0FLIP, the data read back is 0x03. Bit reversal is a useful mathematical function used in algorithms such as the FFT.

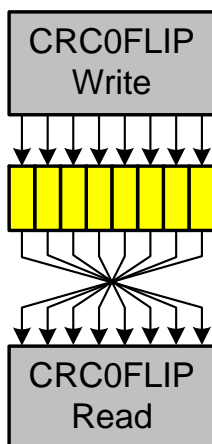

Figure 12.2. Bit Reverse Register

SFR Definition 12.6. CRC0FLIP: CRC0 Bit Flip

Bit	7	6	5	4	3	2	1	0
Name	CRC0FLIP[7:0]							
Type	R/W							
Reset	0	0	0	0	0	0	0	0

SFR Page = 0xF; SFR Address = 0x94

Bit	Name	Function
7:0	CRC0FLIP[7:0]	<p>CRC0 Bit Flip.</p> <p>Any byte written to CRC0FLIP is read back in a bit-reversed order, i.e. the written LSB becomes the MSB. For example:</p> <p>If 0xC0 is written to CRC0FLIP, the data read back will be 0x03.</p> <p>If 0x05 is written to CRC0FLIP, the data read back will be 0xA0.</p>

13. DMA-Enabled Cyclic Redundancy Check Module (CRC1)

Si102x/3x devices include a DMA-enabled cyclic redundancy check module (CRC1) that can perform a CRC of data using an arbitrary 16-bit polynomial. This peripheral can compute CRC results using direct DMA access to data in XRAM.

Using a DMA transfer provides much higher data throughput than using SFR access. Since the CPU can be in Idle mode while the CRC is calculated, CRC1 also provides substantial power savings. The CRC1 module is not restricted to a limited list of fixed polynomials. Instead, the user can specify any valid 16-bit polynomial.

CRC1 accepts a stream of 8-bit data written to the CRC1IN register. A DMA transfer can be used to autonomously transfer data from XRAM to the CRC1IN SFR. The CRC1 module may also be used with SFR access by writing directly to the CRC1IN SFR. After each byte is written, the CRC resultant is updated on the CRC1OUTH:L SFRs. After writing all data bytes, the final CRC results are available from the CRC1OUTH:L registers. The final results may be flipped or inverted using the FLIP and INV bits in the CRC1CN SFR. The initial seed value can be reset to 0x0000 or seeded with 0xFFFF.

13.1. Polynomial Specification

The arbitrary polynomial should be written to the CRC1POLH:L SFRs before writing data to the CRCIN SFR.

A valid 16-bit CRC polynomial must have an x^{16} term and an x^0 term. Theoretically, a 16-bit polynomial might have 17 terms total. However, the polynomial SFR is only 16-bits wide. The convention used is to omit the x^{16} term. The polynomial should be written in big endian bit order. The most significant bit corresponds to the highest order term. Thus, the most significant bit in the CRC1POLL SFR represents the x^{15} term, and the least significant bit in the CRC1POLH SFR represents the x^0 term. The least significant bit of CRC1POLL should always be set to one. The CRC results are undefined if this bit is cleared to a zero.

Figure 13.1 depicts the polynomial representation for the CRC-16-CCIT polynomial $x^{16} + x^{12} + x^5 + 1$, or 0x1021.

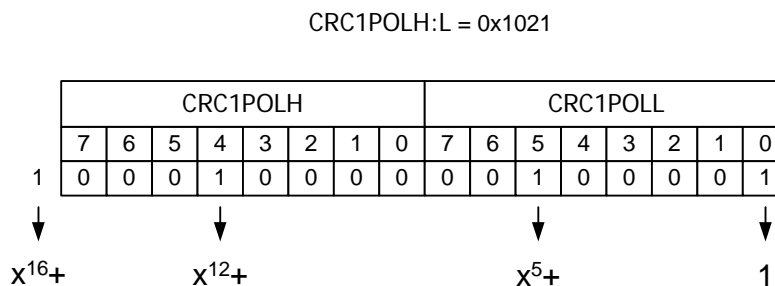

Figure 13.1. Polynomial Representation

13.2. Endianness

The CRC1 module is optimized to process big endian data. Data written to the CRC1IN SFR should be in the normal bit order with the most significant bit stored in bit 7 and the least significant bit stored in bit 0. The input data is shifted left into the CRC engine. The CRC1 module will process one byte at a time and update the results for each byte. When used with the DMA, the first byte to be written should be stored in the lowest address.

Some communications systems may transmit data least significant bit first and may require calculation of a CRC in the transmission bit order. In this case, the bits must be flipped, using the CRC0FLIP SFR, before writing to the CRC1IN SFR. The final 16-bit result may be flipped using the flip bit in the CRC1CN SFR. Note that the polynomial is always written in big endian bit order.

13.3. CRC Seed Value

Normally, the initial value or the CRC results is cleared to 0x0000. However, a CRC might be specified with an initial value preset to all ones (0xFFFF).

The steps to preset the CRC with all ones is as follows:

1. Set the SEED bit to 1.
2. Reset the CRC1 module by setting the CLR bit to 1 in CRC1CN.
3. Clear the SEED bit to 0.

The CRC1 module is not ready to calculate a CRC using a CRC seed value of 0xFFFF.

13.4. Inverting the Final Value

Sometimes it is necessary to invert the final value. This will take the ones complement of the final result.

The steps to flip the final CRC results are as follows:

1. Clear the CRC module by setting the CLR bit in CRC1CN SFR.
2. Write the polynomial to CRC1POLH:L.
3. Write all data bytes to CRC1IN.
4. Set the INV bit in the CRC1CN SFR to invert the final results.
5. Read the final CRC results from CRC1OUTH:L.

Clear the FLIP bit in the CRC1CN SFR.

13.5. Flipping the Final Value

The steps to flip the final CRC results are as follows:

1. Clear the CRC module by setting the CLR bit in CRC1CN SFR.
2. Write the polynomial to CRC1POLH:L.
3. Write all data bytes to CRC1IN.
4. Set the FLIP bit in the CRC1CN SFR to flip the final results.
5. Read the final CRC results from CRC1OUTH:L.
6. Clear the FLIP bit in the CRC1CN SFR.

The flip operation will exchange bit 15 with bit 0, bit 14 with bit 1, bit 13 with bit 2, and so on.

13.6. Using CRC1 with SFR Access

The steps to perform a CRC using SFR access with the CRC1 module is as follow:

1. If desired, set the SEED bit in the CRC1CN SFR to seed with 0xFFFF.
2. Clear the CRC module by setting the CLR bit in the CRC1CN SFR.
3. Clear the SEED bit, if set previously in step 1.
4. Write the polynomial to CRC1POLH:L.
5. Write all data bytes to CRC1IN.
6. If desired, invert and/or flip the final results using the INV and FLIP bits.
7. Read the final CRC results from CRC1OUTH:L.
8. Clear the INV and/or FLIP bits, if set previously in step 6.

Note that all of the CRC1 SFRs are on SFR page 0x2.

13.7. Using the CRC1 module with the DMA

The steps to computing a CRC using the DMA are as follows.

1. If desired, set the SEED bit in CRC1CN to seed with 0xFFFF.
2. Clear the CRC module by setting the CLR bit in CRC1CN SFR.
3. Clear the SEED bit, if set previously in step 1.
4. Write the polynomial to CRC1POLH:L.
5. Configure the DMA for the CRC operation:
 - a. Disable the desired DMA channel by clearing the corresponding bit in DMA0EN.
 - b. Select the desired DMA channel by writing to DMA0SEL.
 - c. Configure the selected DMA channel to use the CRC1IN peripheral request by writing 0x2 to DMA0NCF.
 - d. Enable the DMA interrupt on the selected channel by setting bit 7 of DMA0NCF.
 - e. Write 0 to DMA0NMD to disable wrapping.
 - f. Write the address of the first byte of CRC data to DMA0NBAH:L.
 - g. Write the size of the CRC data in bytes to DMA0NSZH:L.
 - h. Clear the address offset SFRs DMA0A0H:L.
 - i. Enable the interrupt on the desired channel by setting the corresponding bit in DMA0INT.
 - j. Enable the desired channel by setting the corresponding bit in DMA0EN.
 - k. Enable DMA interrupts by setting bit 5 of EIE2.
6. Set the DMA mode bit (bit 3) in the CRC1CN SFR to initiate the CRC operation.
7. Wait on the DMA interrupt.
8. If desired, invert and/or flip the final results using the INV and FLIP bits.
9. Read the final results from CRC1OUTH:L.
10. Clear the INV and/or FLIP bits, if set previously in step 8.

SFR Definition 13.1. CRC1CN: CRC1 Control

Bit	7	6	5	4	3	2	1	0
Name	CLR				DMA	FLIP	INV	SEED
Type	R/W	R	R	R	R/W	R/W	R/W	R/W
Reset	0	0	0	0	0	0	0	0

SFR Page = 0x2; SFR Address = 0xBE; Not Bit-Addressable

Bit	Name	Function
7	RST	Reset. Setting this bit to 1 will reset the CRC module and set the CRC results SFR to the seed value as specified by the SEED bit. The CRC module should be reset before starting a new CRC. This bit is self-clearing.
6:4	Reserved	
3	DMA	DMA Mode. Setting this bit will configure the CRC1 module for DMA mode. Once a DMA channel has been configured to use accept peripheral requests from CRC1, setting this bit will initiate a DMA CRC operation. This bit should be cleared after each CRC DMA transfer.
2	FLIP	Flip. Setting this bit will flip the contents of the 16-bit CRC result SFRs. (CRC0OUTH: CRC0OUTL) This operation is normally performed only on the final CRC results. This bit should be cleared before starting a new CRC computation.
1	INV	Invert. Setting this bit will invert the contents of the 16-bit CRC result SFR. (CRC0OUTH: CRC0OUTL) This operation is normally performed only on the final CRC results. This bit should be cleared before starting a new CRC computation.
0	SEED	Seed Polarity. If this bit is zero, a seed value of 0x0000 will be used. If this bit is 1, a seed value of 0xFFFF will be used. This bit should be set before setting the RST bit.

Si102x/3x

SFR Definition 13.2. CRC1IN: CRC1 Data IN

Bit	7	6	5	4	3	2	1	0
Name	CRC1IN[7:0]							
Type	R/W	R/W	R/W	R/W	R/W	R/W	R/W	R/W
Reset	0	0	0	0	0	0	0	0

SFR Page = 0x2; SFR Address = 0xB9; Not Bit-Addressable

Bit	Name	Function
7:0	CRC1IN[7:0]	CRC1Data IN. CRC Data should be sequentially written, one byte at a time, to the CRC1IN Data input SFR. When the CRC1 module is used with the DMA, the DMA will write directly to this SFR.

SFR Definition 13.3. CRC1POLL: CRC1 Polynomial LSB

Bit	7	6	5	4	3	2	1	0
Name	CRC1POLL[7:0]							
Type	R/W	R/W	R/W	R/W	R/W	R/W	R/W	R/W
Reset	0	0	0	0	0	0	0	0

SFR Page = 0x2; SFR Address = 0xBC; Not Bit-Addressable

Bit	Name	Function
7:0	CRC1POLL[7:0]	CRC1 Polynomial LSB.

SFR Definition 13.4. CRC1POLH: CRC1 Polynomial MSB

Bit	7	6	5	4	3	2	1	0
Name	CRC1POLH[7:0]							
Type	R/W	R/W	R/W	R/W	R/W	R/W	R/W	R/W
Reset	0	0	0	0	0	0	0	0

SFR Page = 0x2; SFR Address = 0xBD; Not Bit-Addressable

Bit	Name	Function
7:0	CRC1POLH[7:0]	CRC1 Polynomial MSB.

SFR Definition 13.5. CRC1OUTL: CRC1 Output LSB

Bit	7	6	5	4	3	2	1	0
Name	CRC1OUTL[7:0]							
Type	R	R	R	R	R	R	R	R
Reset	0	0	0	0	0	0	0	0

SFR Page = 0x2; SFR Address = 0xBA; Not Bit-Addressable

Bit	Name	Function
7:0	CRC1OUTL[7:0]	CRC1 Output LSB

SFR Definition 13.6. CRC1OUTH: CRC1 Output MSB

Bit	7	6	5	4	3	2	1	0
Name	CRC1OUTH[7:0]							
Type	R	R	R	R	R	R	R	R
Reset	0	0	0	0	0	0	0	0

SFR Page = 0x2; SFR Address = 0xBB; Not Bit-Addressable

Bit	Name	Function
7:0	CRC1OUTH[7:0]	CRC1 Output MSB.

14. Advanced Encryption Standard (AES) Peripheral

The Si102x/3x devices include a hardware implementation of the Advanced Encryption Standard Block Cipher as specified in NIST publication FIPS 197 “Advanced Encryption Standard (AES), November 2001. The Rijndael encryption algorithm was chosen by NIST for the AES block cipher. The AES block cipher can be used to encrypt data for wireless communications. Data can be encrypted before transmission and decrypted upon reception. This provides security for private networks.

The AES block cipher is a Symmetric key encryption algorithm. Symmetric Key encryption relies on secret keys that are known by both the sender and receiver. The decryption key may be obtained using a simple transformation of the encryption key. AES is not a public key encryption algorithm.

The AES block Cipher uses a fixed 16 byte block size. So data less than 16 bytes must be padded with zeros to fill the entire block. Wireless data must be padded and transmitted in 16-byte blocks. The entire 16-byte block must be transmitted to successfully decrypt the information.

The AES engine supports key lengths of 128-bits, 192-bits, or 256-bits. A key size of 128-bits is sufficient to protect the confidentiality of classified secret information. The Advanced Encryption Standard was designed to be secure for at least 20 to 30 years. The 128-bit key provides fastest encryption. The 192-bit and 256-bit key lengths may be used to protect highly sensitive classified top secret information.

Since symmetric key encryption relies on secret keys, the security of the data can only be protected if the key remains secret. If the encryption key is stored in flash memory, then the entire flash should be locked to ensure the encryption key cannot be discovered. (See flash security.)

The basic AES block cipher is implemented in hardware. This hardware accelerator provides performance that may be 1000 times faster than a software implementation. The higher performance translates to a power savings for low-power wireless applications.

The AES block cipher, or block cipher modes based on the AES block cipher, is used in many wireless standards. These include several IEEE standards in the wireless PAN (802.15) and wireless LAN (802.11) working groups.

14.1. Hardware Description

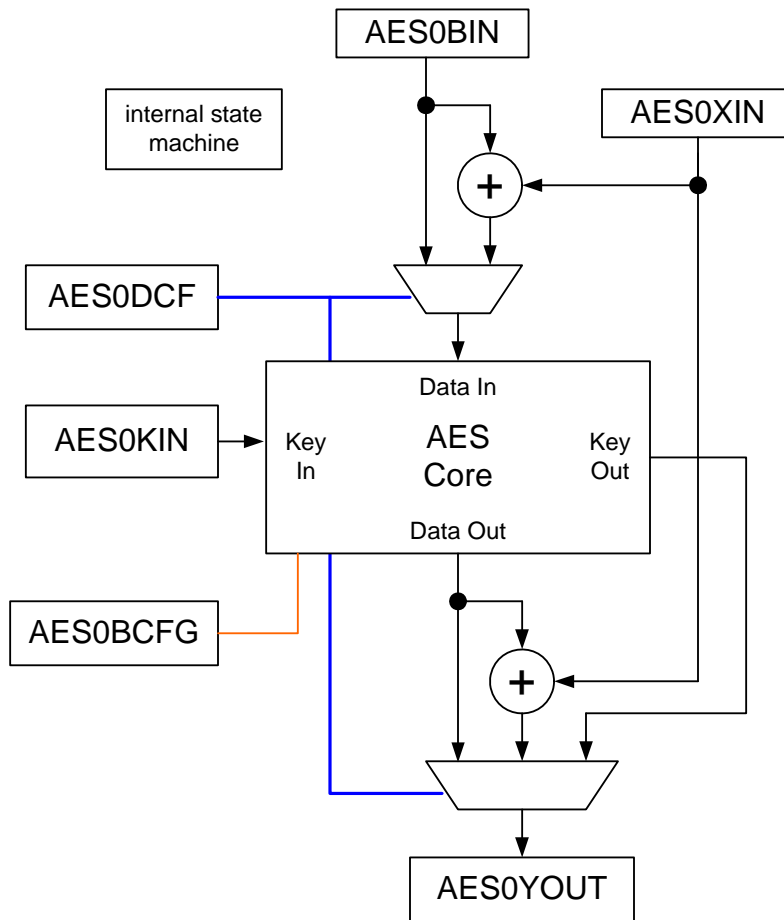

Figure 14.1. AES Peripheral Block Diagram

The AES Encryption module consists of the following elements:

- AES Encryption/Decryption Core
- Configuration SFRs
- Key input SFR
- Data SFRs
- Input Multiplexer
- Output Multiplexer
- Input Exclusive OR block
- Output Exclusive OR block
- Internal State Machine

14.1.1. AES Encryption/Decryption Core

The AES Encryption/Decryption Core is a digital implementation of the Advanced Encryption Standard block cipher. The core may be used for either encryption or decryption. Encryption may be selected by setting bit 5 in the AES0BCFG SFR. When configured for encryption, plaintext is written to the AES Core data input and the encrypted ciphertext is read from the Data Output. Conversely, when configured for Decryption, encrypted ciphertext is written to the data input and decrypted plaintext is read from the Data Output.

When configured for Encryption, the encryption key must be written to the Key Input. When configured for decryption, the decryption key must be written to the Key Input.

The AES core may also be used to generate a decryption key from a known encryption key. To generate a decryption key, the core must be configured for encryption, the encryption key is written to the Key Input, and the Decryption Key may be read from the Key output.

AES is a symmetric key encryption algorithm. This means that the decryption key may be generated from an encryption key using a simple algorithm. Both keys must remain secret. If security of the encryption key is compromised, one can easily generate the decryption key.

Since it is easy to generate the decryption key, only the encryption key may be stored in Flash memory.

14.1.2. Data SFRs

The data SFRs are used for the data flow into and out of the AES module. When used with the DMA, the DMA itself will write to and read from the data SFRs. When used in manual mode, the data must be written to the data SFRs one byte at a time in the proper sequence.

The AES0KIN SFR provides a data path for the AES core Key input. For an encryption operation, the encryption key is written to the AES0KIN SFR, either by the DMA or direct SFR access. For a decryption operation, the decryption key must be written to the AES0KIN SFR.

The AES0BIN is the direct data input SFR for the AES block. For a simple encryption operation, the plaintext is written to the AES0BIN SFR – either by the DMA or direct SFR access. For decryption, the ciphertext to be decrypted is written to the AES0BIN SFR. The AES0BIN SFR is also used together with the AES0XIN when an exclusive OR operation is required on the input data path.

The AES0XIN SFR provides an input data path to the exclusive OR operator. The AES0XIN is not used for simple AES block cipher encryption or decryption. It is only use for block cipher modes that require an exclusive OR operator on the input or output data.

The AES core requires that the input data bytes are written in a specific order. When used with the DMA, this is managed by the internal state machine. When using direct SFR access, each of input data must be written one byte at a time to each SFR in this particular order.

1. Write AES0BIN
2. Write AES0XIN (optional)
3. Write AES0KIN

This sequence is repeated 16 times. When using a 192-bit or 256-bit key length, the remaining additional key bytes are written after writing all sixteen of the AES0BIN and AES0XIN bytes.

After encryption or decryption is completed, the resulting data may be read from the AES0YOUT. Optionally, exclusive OR data may be written to the AES0XIN SFR before reading the AES0YOUT SFR.

1. Write AES0XIN (optional)
2. Read AES0YOUT

14.1.3. Configuration sfrs

The AES Module has two configuration SFRs. The AES0BCFG SFR is used to configure the AES core. Bits 0 and 1 are used to select the key size. The AES core supports 128-bit, 192-bit and 256-bit encryption. Bit 2 selects encrypt or decrypt. The AES enable bit (bit 3) is used to enable the AES module and start new encryption operation. The AES DONE bit (bit 5) is the AES interrupt flag that signals a block of data has been completely encrypted or decrypted and is ready to be read from the AES0YOUT SFR. Note that the AES DONE interrupt is not normally used when the AES module is used with the DMA. Instead, the DMA interrupt is used to signal that the encrypted or decrypted data has been transferred completely to memory. The DMA done interrupt is normally only used with direct SFR access.

The AES0DCFG SFR is used to select the data path for the AES module. Bits 0 through 2 are used to select the input and output multiplexer configuration. The AES data path should be configured prior to initiating a new encryption or decryption operation.

14.1.4. Input Multiplexer

The input multiplexer is used to select either the contents of the AES0BIN SFR or the contents of the AES0BIN SFR exclusive ORed with the contents of the AES0XIN SFR. The exclusive OR input data path provides support for CBC encryption.

14.1.5. Output Multiplexer

The output multiplexer selects the data source for the AES0YOUT SFR. The three possible sources are the AES Core data output, the AES core key output, and the AES core data output exclusive ORed with the AES0XIN SFR.

The AES core data output is used for simple encryption and decryption.

The exclusive OR output data path provides support for CBC mode decryption and CTR mode encryption/decryption. The AES0XIN is the source for both input and output exclusive OR data. When the AES0XIN is used with the input exclusive OR data path, the AES0XIN data is written in sequence with the AES0BIN data. When used with the output XRO data path, the AES0XIN data is written after the encryption or decryption operation is complete.

The Key output is used to generate an inverse key. To generate a decryption key from an encryption key, the AES core should be configured for an encryption operation. To generate an encryption key from a decryption key, the AES core should be configured for a decryption operation.

14.1.6. Internal State Machine

The AES module has an internal state machine that manages the data flow. The internal state machine accommodates the two different usage scenarios. When using the DMA, the internal state machine will send peripheral requests to the DMA requesting the DMA to transfer data from XRAM to the AES module input SFRs. Upon the completion of one block of data, the AES module will send peripheral requests requesting data to be transferred from the AES0YOUT SFR to XRAM. These peripheral requests are managed by the internal state machine.

When not using the DMA, data must be written and read in a specific order. The DMA state machine will advance with each byte written or read.

The internal state machine may be reset by clearing the enable bit in the AESBGFG SFR. Clearing the enable bit before encryption or decryption operation will ensure that the state machine starts at the proper state.

When encrypting or decrypting multiple blocks it is not necessary to disable the AES module between blocks, as long as the proper sequence of events is obeyed.

14.2. Key Inversion

The key output is used to generate an inverse key. To generate a decryption key from an encryption key, the AES core should be configured for an encryption operation. Dummy data and the encryption key are written to the AES0BIN and AES0KIN SFRs respectively. The output multiplexer should be configured to output the decryption key to the AES0YOUT SFR.

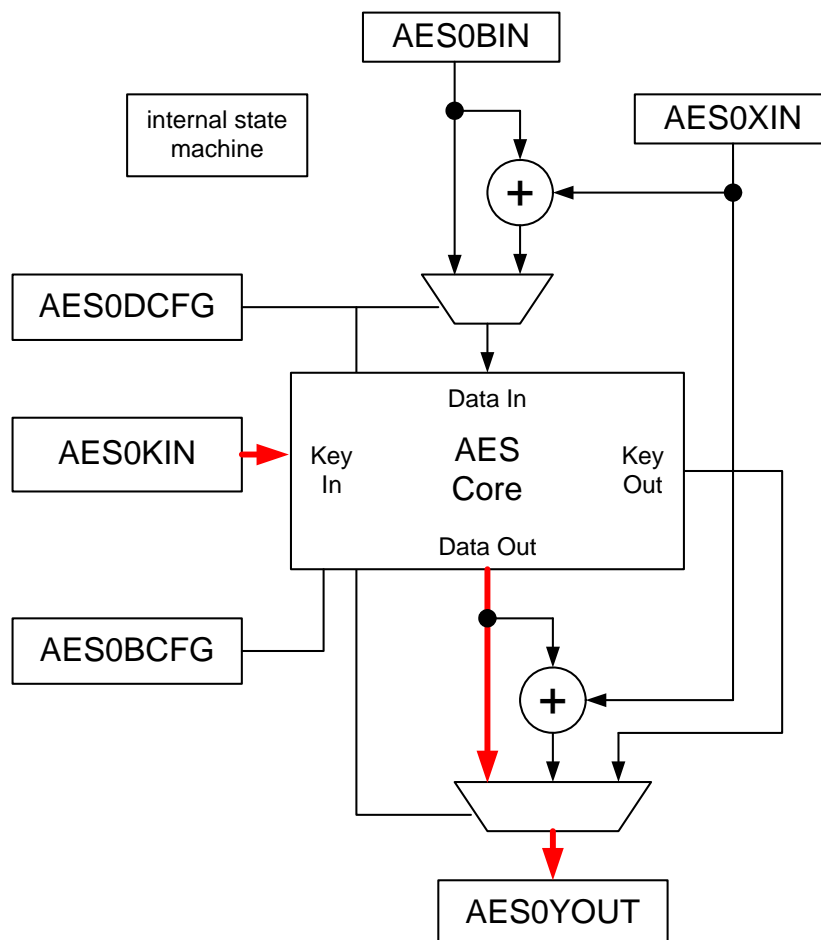

Figure 14.2. Key Inversion Data Flow

The dummy data may be zeros or arbitrary data. The content of the dummy data does not matter. But sixteen bytes of data must be written to the AES0BIN SFR to generate the inverse key.

14.2.1. Key Inversion using DMA

Normally, the AES block is used with the DMA. This provides the best performance and lowest power consumption. Code examples are provided in 8051 compiler independent C code using the DMA. It is highly recommended to use the code examples. The steps are listed here for completeness.

Steps to generate the Decryption Key from Encryption Key

- Prepare encryption key and dummy data in XRAM.
- Reset AES module by clearing bit 3 of AES0BCFG.
- Disable the first three DMA channels by clearing bits 0 to 2 in DMA0EN.
- Configure the first DMA channel for AES0KIN.
 - Select the first DMA channel by writing 0x00 to DMA0SEL.
 - Configure the first DMA channel to move XRAM to AES0KIN by writing 0x05 to DMA0NCF.
 - Clear DMA0NMD to disable wrapping.
 - Write the XRAM address of the encryption key to DMA0NBAH and DMA0NBAL.
 - Write the key length in bytes to DMA0NSZL.
 - Clear DMA0NSZH
 - Clear DMA0NAOH and DMA0NAOL.
- Configure the second DMA channel for AES0BIN.
 - Select the second DMA channel by writing 0x01 to DMA0SEL.
 - Configure the second DMA channel to move xram to AES0BIN sfr by writing 0x06 to the DMA0NCF sfr.
 - Clear DMA0NMD to disable wrapping.
 - Write the xram address of dummy data to DMA0NBAH and DMA0NBAL.
 - Write 0x10 (16) to DMA0NSZL.
 - Clear DMA0NSZH
 - Clear DMA0NAOH and DMA0NAOL
- Configure the third DMA channel for AES0YOUT.
 - Select the third DMA channel by writing 0x02 to DMA0SEL.
 - Configure the third DMA channel to move the contents of AES0YOUT to XRAM by writing 0x08 to DMA0NCF.
 - Enable transfer complete interrupt by setting bit 7 of DMA0NCF.
 - Clear DMA0NMD to disable wrapping.
 - Write the XRAM address for the decryption key to DMA0NBAH and DMA0NBAL.
 - Write the key length in bytes to DMA0NSZL.
 - Clear DMA0NSZH.
 - Clear DMA0NAOH and DMA0NAOL.
- Clear first three DMA interrupts by clearing bits 0 to 2 in DMA0INT.
- Enable first three DMA channels setting bits 0 to 2 in DMA0EN
- Configure the AES module data flow for inverse key generation by writing 0x04 to AES0DCFG.
- Write key size to bits 1 and 0 of AES0BCFG.
- Configure the AES core for encryption by setting bit 2 of AES0BCFG.
- Initiate the encryption operation by setting bit 3 of AES0BCFG.
- Wait on the DMA interrupt from DMA channel 2.
- Disable the AES module by clearing bit 2 of AES0BCFG.
- Disable the DMA by writing 0x00 to DMA0EN.

Si102x/3x

The key and data to be encrypted should be stored as an array with the first byte to be encrypted at the lowest address. The value of the big endian bit of the DMACF0 SFR does not matter. The AES block uses only one byte transfers, so there is no particular endianness associated with a one byte transfer.

The dummy data can be zeros or any value. The encrypted data is discarded, so the value of the dummy data does not matter.

It is not strictly required to use DMA channels 0, 1, and 2. Any three DMA channels may be used. The internal state machine of the AES module will send the peripheral requests in the required order.

If the other DMA channels are going to be used concurrently with encryption, then only the bits corresponding to the encryption channels should be manipulated in DMAEN and DMAONT SFRs.

14.2.2. Key Inversion using SFRs

Normally, the AES block is used with the DMA. This provides the best performance and lowest power consumption. However, it is also possible to use the DMA with direct SFR access. The steps are documented here for completeness.

Steps to generate the decryption key from the encryption key using SFR access follow:

- First configure the AES block for key inversion:
 - Reset AES module by writing 0x00 to AES0BCFG.
 - Configure the AES Module data flow for inverse key generation by writing 0x04 to AES0DCFG.
 - Write key size to bits 1 and 0 of AES0BCFG.
 - Configure the AES core for encryption by setting bit 2 of AES0BCFG.
 - Enable the AES core by setting bit 3 of AES0BCFG.
- Write the dummy data alternating with key data:
 - Write the first dummy byte to AES0BIN
 - Write the first key byte to AES0KIN
 - Repeat until all dummy data bytes are written
- If using 192-bit and 256-bit key, write remaining key bytes to AES0KIN:
- Wait on AES done interrupt or poll bit 5 of AES0BCFG
- Read first byte of the decryption key from AES0YOUT

14.2.3. Extended Key Output Byte Order

When using a key length of 128-bits, the key output is in the same order as the bytes were written. When using an extended key of 192-bits or 256-bits. The extended portion of the key comes out first, before the first 16-bytes of the extended key. This is illustrated in Table 14.1.

Table 14.1. Extended Key Output Byte Order

Size		Input Order	Output Order		
Bits	Bytes				
128	16	K0...15	K0...15		
192	24	K0...23	K16...23	K0...15	
256	32	K0...31	K16...23	K24...31	K0...15

14.2.4. Using the DMA to unwrap the extended Key

When used with the DMA, the address offset `sfr DMANAOH/L` may be manipulated to store the extended key in the desired order. This requires two DMA transfers for the `AES0YOUT` channel. When using a 192-bit key, the `DMA0NSZ` can be set to 24 bytes and the `DMA0NA0` set to 16. This will place the last 8 bytes of the 192-bit key in the desired location as shown in Table 14.2. The `Yout` arrow indicates the address offset position after each 8 bytes are transferred. Enabling the `WRAP` bit in `DMA0NMD` will reset the `DMA0NAO` value after byte 23. Then the `DMA0NZ` can be reset to 16 for the remaining sixteen bytes.

Table 14.2. 192-Bit Key DMA Usage



When using a 256-bit key, `DMA0NSZ` can be set to 32 and `DMA0NAOL` set to 16. This will place the last 16 bytes of the 256-bit key in the desired location as shown in Table 14.3. Enabling the `WRAP` bit in `DMA0NMD` will reset the `DMA0NAO` value after byte 31. Then `DMA0NZ` can be set to 16 for the remaining sixteen bytes.

Table 14.3. 256-bit Key DMA Usage

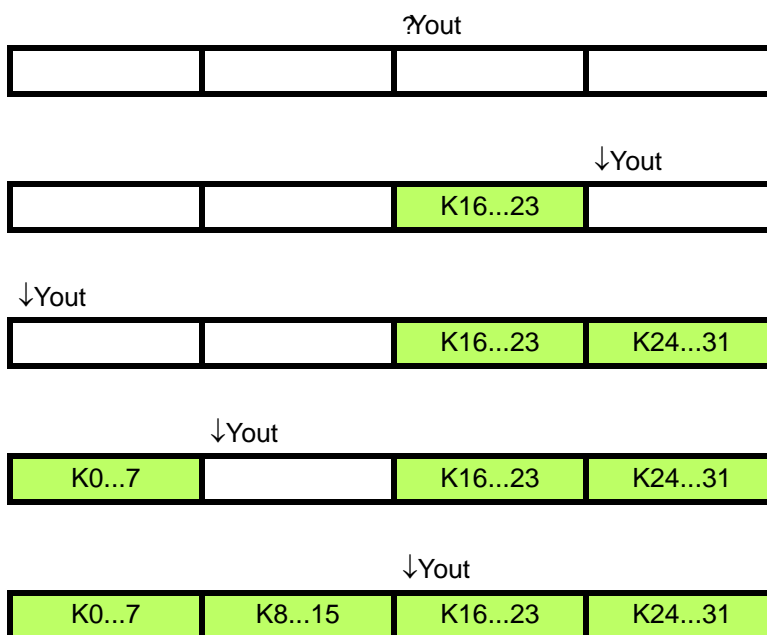

14.3. AES Block Cipher

The basic AES Block Cipher is the basic encryption/decryption algorithm as defined by the NIST standard. A clock cipher mode is a method of encrypting and decrypting one block of data. The input data and output data are not manipulated, chained, or exclusive ORed with other data. This simple block cipher mode is sometimes called the Electronic Code Book (ECB) mode. This mode is illustrated in Figure 14.3

Each operation represents one block (sixteen bytes) of data. The plaintext is the plain unencrypted data. The ciphertext is the encrypted data. The encryption key and decryption keys are symmetric. The decryption key is the inverse key of the encryption key. Note that the Encryption operation is not the same as the decryption operation. The two operations are different and the AES core operates differently depending on whether encryption or decryption is selected.

Note that each encryption or decryption operation is independent of other operations. Also note that the same key is used over and over again for each operation.

14.4. AES Block Cipher Data Flow

The AES0 module data flow for AES Block Cipher encryption and decryption shown in Figure 14.3. The data flow is the same for encryption and decryption. The AES0DCF SFR is always configured to route the AES core output to AES0YOUT. The XOR on the input and output paths are not used.

For an encryption operation, the core is configured for an encryption cipher, the encryption key is written to AES0KIN, the plaintext is written to the AES0BIN SFR. and the ciphertext is read from AES0YOUT.

For a decryption operation, the core is configured for an decryption cipher, the decryption key is written to AES0KIN, the ciphertext is written to the AES0BIN SFR. and the plaintext is read from AES0YOUT.

The key size is set to the desired key size.

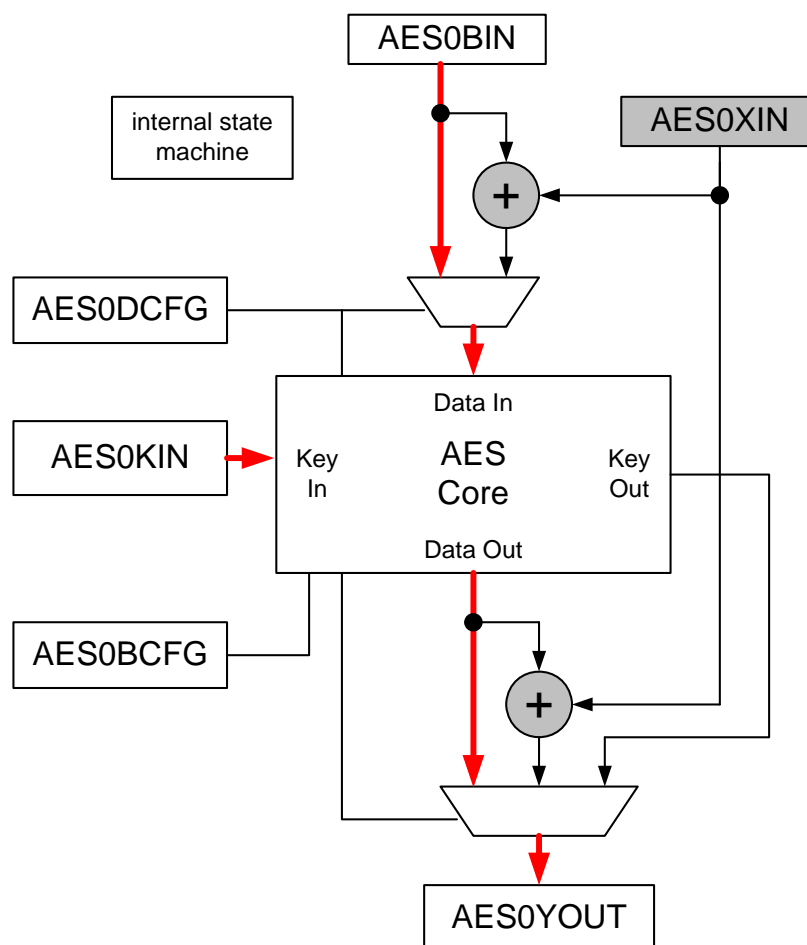

Figure 14.3. AES Block Cipher Data Flow

14.4.1. AES Block Cipher Encryption using DMA

Normally, the AES block is used with the DMA. This provides the best performance and lowest power consumption. Code examples are provided in 8051 compiler independent C code using the DMA. It is highly recommended to use the code examples. The steps are listed here for completeness.

Steps to encrypt data using Simple AES block encryption (ECB mode)

- Prepare encryption Key and data to be encrypted in xram.
- Reset AES module by clearing bit 2 of AES0BCFG.
- Disable the first three DMA channels by clearing bits 0 to 2 in DMA0EN.
- Configure the first DMA channel for AES0KIN
 - Select the first DMA channel by writing 0x00 to DMA0SEL
 - Configure the second DMA channel to move XRAM to AES0KIN by writing 0x05 to DMA0NCF
 - Write 0x01 to DMA0NMD to enable wrapping
 - Write the XRAM location of the encryption key to DMA0NBAH and DMA0NBAL.
 - Write the key length in bytes to DMA0NSZL
 - Clear DMA0NSZH
 - Clear DMA0NAOH and DMA0NAOL.
- Configure the second DMA channel for AES0BIN sfr.
 - Select the second DMA channel by writing 0x01 to DMA0SEL.
 - Configure the second DMA channel to move XRAM to AES0BIN by writing 0x06 to DMA0NCF.
 - Clear DMA0NMD to disable wrapping.
 - Write the XRAM address of the data to be encrypted to DMA0NBAH and DMA0NBAL.
 - Write the number of bytes to be encrypted in multiples of 16 bytes to DMA0NSZH and DMA0NSZL.
 - Clear DMA0NAOH and DMA0NAOL.
- Configure the third DMA channel for AES0YOUT
 - Select the third DMA channel by writing 0x02 to DMA0SEL
 - Configure the third DMA channel to move the contents of AES0YOU to XRAM by writing 0x08 to DMA0NCF.
 - Enable transfer complete interrupt by setting bit 7 of DMA0NCF.
 - Clear DMA0NMD to disable wrapping.
 - Write the XRAM address for the encrypted data to DMA0NBAH and DMA0NBAL.
 - Write the number of bytes to be encrypted in multiples of 16 bytes to DMA0NSZH and DMA0NSZL.
 - Clear DMA0NAOH and DMA0NAOL.
- Clear first three DMA interrupts by clearing bits 0 to 2 in DMA0INT.
- Enable first three DMA channels by setting bits 0 to 2 in DMA0EN.
- Configure the AES module data flow for AES Block Cipher by writing 0x00 to AES0DCFG.
- Write key size to bits 1 and 0 of AES0BCFG
- Configure the AES core for encryption by setting bit 2 of AES0BCFG
- Initiate the encryption operation by setting bit 3 of AES0BCFG
- Wait on the DMA interrupt from DMA channel 2
- Disable the AES module by clearing bit 2 of AES0BCFG
- Disable the DMA by writing 0x00 to DMA0EN

14.4.2. AES Block Cipher Encryption using SFRs

- First Configure AES module for AES Block Cipher
 - Reset AES module by writing 0x00 to AES0BCFG.
 - Configure the AES module data flow for AES Block Cipher by writing 0x00 to AES0DCFG.
 - Write key size to bits 1 and 0 of AES0BCFG.
 - Configure the AES core for encryption by setting bit 2 of AES0BCFG.
 - Enable the AES core by setting bit 3 of AES0BCFG.
- Repeat alternating write sequence 16 times
 - Write plaintext byte to AES0BIN.
 - Write encryption key byte to AES0KIN.
- Write remaining encryption key bytes to AES0KIN for 192-bit and 256-bit encryption only.
- Wait on AES done interrupt or poll bit 5 of AES0BCFG.
- Read 16 encrypted bytes from AES0YOUT.

If encrypting multiple blocks, this process may be repeated. It is not necessary reconfigure the AES module for each block.

14.5. AES Block Cipher Decryption

14.5.1. AES Block Cipher Decryption using DMA

Normally, the AES block is used with the DMA. This provides the best performance and lowest power consumption. Code examples are provided in 8051 compiler independent C code using the DMA. It is highly recommended to use the code examples. The steps are listed here for completeness.

- Prepare decryption key and data to be decryption in XRAM.
- Reset AES module by clearing bit 2 of AES0BCFG.
- Disable the first three DMA channels by clearing bits 0 to 2 in DMA0EN.
- Configure the first DMA channel for AES0KIN
 - Select the first DMA channel by writing 0x00 to DMA0SEL
 - Configure the first DMA channel to move XRAM to AES0KIN by writing 0x05 to DMA0NCF
 - Write 0x01 to DMA0NMD to enable wrapping
 - Write the XRAM location of the decryption key to DMA0NBAH and DMA0NBAL.
 - Write the key length in bytes to DMA0NSZL
 - Clear DMA0NSZH
 - Clear DMA0NAOH and DMA0NAOL.
- Configure the second DMA channel for AES0BIN.
 - Select the second DMA channel by writing 0x01 to DMA0SEL.
 - Configure the second DMA channel to move XRAM to AES0BIN by writing 0x06 to DMA0NCF.
 - Clear DMA0NMD to disable wrapping.
 - Write the XRAM address of the data to be decrypted to DMA0NBAH and DMA0NBAL.
 - Write the number of bytes to be decrypted in multiples of 16 bytes to DMA0NSZH and DMA0NSZL.
 - Clear DMA0NAOH and DMA0NAOL.
- Configure the third DMA channel for AES0YOUT
 - Select the third DMA channel by writing 0x02 to DMA0SEL
 - Configure the third DMA channel to move the contents of AES0YOUT to XRAM by writing 0x08 to DMA0NCF
 - Enable transfer complete interrupt by setting bit 7 of DMA0NCF
 - Clear DMA0NMD to disable wrapping
 - Write the XRAM address for decrypted data to DMA0NBAH and DMA0NBAL.
 - Write the number of bytes to be decrypted in multiples of 16 bytes to DMA0NSZH and DMA0NSZL.
 - Clear DMA0NSZH
 - Clear DMA0NAOH and DMA0NAOL.
- Clear first three DMA interrupts by clearing bits 0 to 2 in DMA0INT.
- Enable first three DMA channels setting bits 0 to 2 in DMA0EN
- Configure the AES module data flow for AES Block Cipher by writing 0x00 to AES0DCFG.
- Write key size to bits 1 and 0 of AES0BCFG
- Configure the AES core for decryption by clearing bit 2 of AES0BCFG
- Initiate the encryption operation by setting bit 3 of AES0BCFG
- Wait on the DMA interrupt from DMA channel 2
- Disable the AES Module by clearing bit 2 of AES0BCFG
- Disable the DMA by writing 0x00 to DMA0EN

14.5.2. AES Block Cipher Decryption using SFRs

- First, configure AES module for AES Block Cipher
 - Reset AES module by writing 0x00 to AES0BCFG.
 - Configure the AES Module data flow for AES Block Cipher by writing 0x00 to AES0DCFG.
 - Write key size to bits 1 and 0 of AES0BCFG.
 - Configure the AES core for decryption by setting bit 2 of AES0BCFG.
 - Enable the AES core by setting bit 3 of AES0BCFG.
- Repeat alternating write sequence 16 times
 - Write ciphertext byte to AES0BIN.
 - Write decryption key byte to AES0KIN.
- Write remaining decryption key bytes to AES0KIN for 192-bit and 256-bit decryption only.
- Wait on AES done interrupt or poll bit 5 of AES0BCFG.
- Read 16 plaintext bytes from AES0YOUT.

If decrypting multiple blocks, this process may be repeated. It is not necessary reconfigure the AES module for each block.

14.6. Block Cipher Modes

14.6.1. Cipher Block Chaining Mode

The Cipher Block Chaining (CBC) algorithm significantly improves the strength of basic AES encryption by making each block encryption be a function of the previous block in addition to the current plaintext and key. This algorithm is shown in Figure 14.4

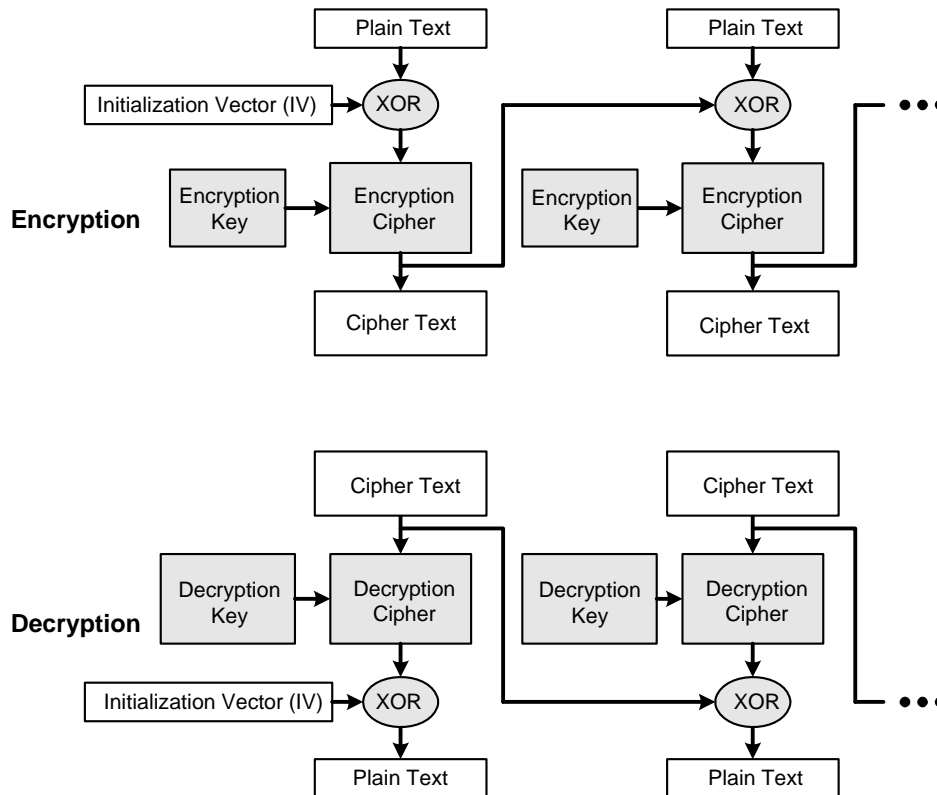

Figure 14.4. Cipher Block Chaining Mode

14.6.1.1. CBC Encryption Data Flow

The AES0 module data flow for CBC encryption is shown in Figure 14.5. The plaintext is written to AES0BIN. For the first block, the initialization vector is written to AES0XIN. For subsequent blocks, the previous block ciphertext is written to AES0XIN. AES0DCFG is configured to XOR AES0XIN with AES0BIN for the AES core data input. The XOR on the output is not used. The AES core is configured for an encryption operation. The encryption key is written to AES0KIN. The key size is set to the desired key size.

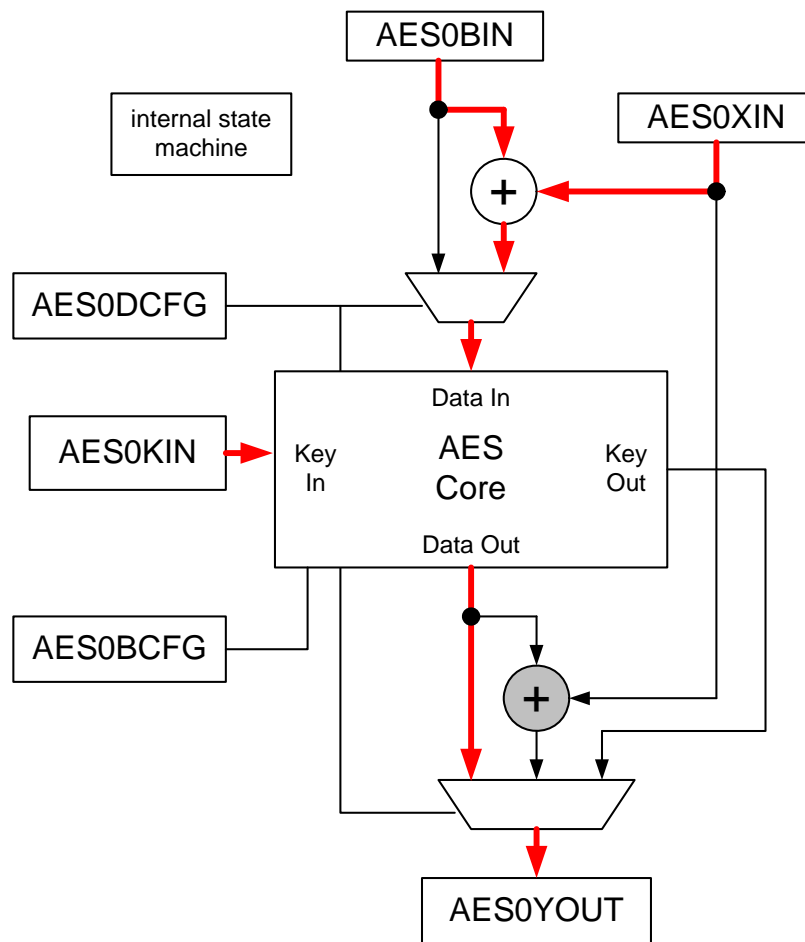

Figure 14.5. CBC Encryption Data Flow

14.6.2. CBC Encryption Initialization Vector Location

The first block to be encrypted uses the initialization vector for the AES0XIN data. Subsequent blocks will use the encrypted ciphertext from the previous block. The DMA is capable of encrypting multiple blocks. If the initialization is located at an arbitrary location in XRAM, the DMA base address location will need to be changed to the start of the encrypted ciphertext after encrypting the first block. However, if the initialization vector is located in XRAM immediately before the encrypted ciphertext, the pointer will be advanced to the start of the encrypted ciphertext, and multiple blocks can be encrypted autonomously.

14.6.3. CBC Encryption using DMA

Normally, the AES block is used with the DMA. This provides the best performance and lowest power consumption. Code examples are provided in 8051 compiler independent C code using the DMA. It is highly recommended to use the code examples. The steps are listed here for completeness.

- Prepare encryption key, initialization vector, and data to be encrypted in XRAM.
(The initialization vector should be located immediately before the data to be encrypted to encrypt multiple blocks.)
- Reset AES module by clearing bit 2 of AES0BCFG.
- Disable the first four DMA channels by clearing bits 0 to 3 in DMA0EN.
- Configure the first DMA channel for AES0KIN
 - Select the first DMA channel by writing 0x00 to DMA0SEL
 - Configure the first DMA channel to move XRAM to AES0KIN by writing 0x05 to DMA0NCF
 - Write 0x01 to DMA0NMD to enable wrapping
 - Write the XRAM location of the encryption key to DMA0NBAH and DMA0NBAL.
 - Write the key length in bytes to DMA0NSZL
 - Clear DMA0NSZH
 - Clear DMA0NAOH and DMA0NAOL
- Configure the second DMA channel for AES0BIN.
 - Select the second DMA channel by writing 0x01 to DMA0SEL.
 - Configure the second DMA channel to move XRAM to AES0BIN by writing 0x06 to DMA0NCF.
 - Clear DMA0NMD to disable wrapping.
 - Write the XRAM address of the data to be encrypted to DMA0NBAH and DMA0NBAL.
 - Write the number of bytes to be encrypted in multiples of 16 bytes to DMA0NSZH and DMA0NSZL.
 - Clear DMA0NAOH and DMA0NAOL.
- Configure the third DMA channel for AES0XIN.
 - Select the third DMA channel by writing 0x02 to DMA0SEL.
 - Configure the third DMA channel to move xram to AES0XIN sfr by writing 0x07 to the DMA0NCF sfr.
 - Clear DMA0NMD to disable wrapping.
 - Write the XRAM address of the initialization vector to DMA0NBAH and DMA0NBAL.
 - Write the number of bytes to be encrypted in multiples of 16 bytes to DMA0NSZH and DMA0NSZL.
 - Clear DMA0NAOH and DMA0NAOL.
- * Configure the fourth DMA channel for the AES0YOUT sfr
 - Select the fourth channel by writing 0x03 to DMA0SEL
 - Configure the fourth DMA channel to move the contents of AES0YOUT to XRAM by writing 0x08 to DMA0NCF
 - Enable transfer complete interrupt by setting bit 7 of DMA0NCF
 - Clear DMA0NMD to disable wrapping
 - Write the XRAM address for the encrypted data to DMA0NBAH and DMA0NBAL.
 - Write the number of bytes to be encrypted in multiples of 16 bytes to DMA0NSZH and DMA0NSZL.
 - Clear DMA0NAOH and DMA0NAOL.
- Clear first four DMA interrupts by clearing bits 0 to 3 in DMA0INT.
- Enable first four DMA channels by setting bits 0 to 3 in DMA0EN
- Configure the AES module data flow for XOR on input data by writing 0x01 to AES0DCFG.

Si102x/3x

- Write key size to bits 1 and 0 of AES0BCFG
- Configure the AES core for encryption by setting bit 2 of AES0BCFG
- Initiate the encryption operation by setting bit 3 of AES0BCFG
- Wait on the DMA interrupt from DMA channel 3
- Disable the AES Module by clearing bit 2 of AES0BCFG
- Disable the DMA by writing 0x00 to DMA0EN

14.6.3.1. CBC Encryption using SFRs

- First Configure the AES module for CBC encryption
 - Reset AES module by writing 0x00 to AES0BCFG.
 - Configure the AES module data flow for XOR on input data by writing 0x01 to AES0DCFG.
 - Write key size to bits 1 and 0 of AES0BCFG.
 - Configure the AES core for encryption by setting bit 2 of AES0BCFG.
 - Enable the AES core by setting bit 3 of AES0BCFG.
- Repeat alternating write sequence 16 times
 - Write plaintext byte to AES0BIN.
 - Write initialization vector to AES0XIN
 - Write encryption key byte to AES0KIN.
- Write remaining encryption key bytes to AES0KIN for 192-bit and 256-bit decryption only.
- Wait on AES done interrupt or poll bit 5 of AES0BCFG.
- Read 16 encrypted bytes from AES0YOUT.

If encrypting multiple blocks, this process may be repeated. It is not necessary reconfigure the AES module for each block. When using Cipher Block Chaining, the initialization vector is written to AES0XIN for the first block only, as described. Additional blocks will chain the encrypted data from the previous block.

14.6.4. CBC Decryption

The AES0 module data flow for CBC decryption is shown in Figure 14.6. The ciphertext is written to AES0BIN. For the first block, the initialization vector is written to AES0XIN. For subsequent blocks, the previous block ciphertext is written to AES0XIN. AES0DCFG is configured to XOR AES0XIN with the AES core data output. The XOR on the input is not used. The AES core is configured for a decryption operation. The decryption key is written to AES0KIN. The key size is set to the desired key size.

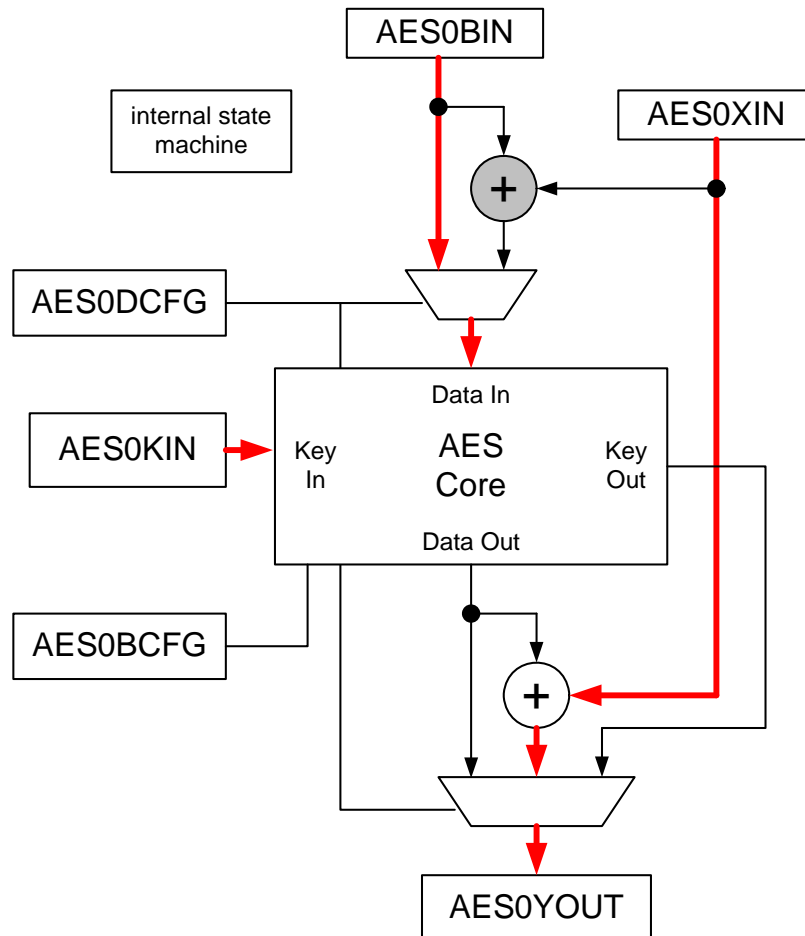

Figure 14.6. CBC Decryption Data Flow

14.6.4.1. CBC Decryption using DMA

Normally, the AES block is used with the DMA. This provides the best performance and lowest power consumption. Code examples are provided in 8051 compiler independent C code using the DMA. It is highly recommended to use the code examples. The steps are listed here for completeness.

- Prepare decryption key, initialization vector, and data to be decrypted in XRAM.
- The initialization vector should be located immediately before the data to be decrypted to decrypt multiple blocks.
- Reset the AES module by clearing bit 2 of AES0BCFG.
- Disable the first four DMA channels by clearing bits 0 to 3 in DMA0EN.
- Configure the first DMA channel for AES0KIN
 - Select the first DMA channel by writing 0x00 to DMA0SEL
 - Configure the first DMA channel to move XRAM to AES0KIN by writing 0x05 to DMA0NCF
 - Write 0x01 to DMA0NMD to enable wrapping
 - Write the XRAM location of the decryption key to DMA0NBAH and DMA0NBAL.
 - Write the key length in bytes to DMA0NSZL
 - Clear DMA0NSZH
 - Clear DMA0NAOH and DMA0NAOL
- Configure the second DMA channel for AES0BIN.
 - Select the second DMA channel by writing 0x01 to DMA0SEL.
 - Configure the second DMA channel to move XRAM to AES0BIN by writing 0x06 to DMA0NCF.
 - Clear DMA0NMD to disable wrapping.
 - Write the XRAM address of the data to be decrypted to DMA0NBAH and DMA0NBAL.
 - Write the number of bytes to be decrypted in multiples of 16 bytes to DMA0NSZH and DMA0NSZL.
 - Clear DMA0NAOH and DMA0NAOL.
- Configure the third DMA channel for AES0XIN.
 - Select the third DMA channel by writing 0x02 to DMA0SEL.
 - Configure the third DMA channel to move XRAM to AES0XIN by writing 0x07 to DMA0NCF.
 - Clear DMA0NMD to disable wrapping.
 - Write the XRAM address of the initialization vector to DMA0NBAH and DMA0NBAL.
 - Write the number of bytes to be decrypted in multiples of 16 bytes to DMA0NSZH and DMA0NSZL.
 - Clear DMA0NAOH and DMA0NAOL.
- Configure the fourth DMA channel for AES0YOUT
 - Select the fourth channel by writing 0x03 to DMA0SEL
 - Configure the fourth DMA channel to move the contents of AES0YOUT to XRAM by writing 0x08 to DMA0NCF
 - Enable transfer complete interrupt by setting bit 7 of DMA0NCF
 - Clear DMA0NMD to disable wrapping
 - Write the XRAM address for the decrypted data to DMA0NBAH and DMA0NBAL.
 - Write the number of bytes to be decrypted in multiples of 16 bytes to DMA0NSZH and DMA0NSZL.
 - Clear DMA0NAOH and DMA0NAOL.
- Clear first four DMA interrupts by clearing bits 0 to 3 in DMA0INT.
- Enable first four DMA channels setting bits 0 to 3 in DMA0EN
- Configure the AES module data flow for XOR on output data by writing 0x02 to AES0DCFG.
- Write key size to bits 1 and 0 of AES0BCFG
- Configure the AES core for decryption by clearing bit 2 of AES0BCFG
- Initiate the decryption operation by setting bit 3 of AES0BCFG
- Wait on the DMA interrupt from DMA channel 3
- Disable the AES Module by clearing bit 2 of AES0BCFG
- Disable the DMA by writing 0x00 to DMA0EN

14.6.4.2. CBC Decryption using SFRs

- First Configure AES Module for CBC Block Cipher Mode Decryption
 - Reset the AES module by writing 0x00 to AES0BCFG.
 - Configure the AES Module data flow for XOR on output data by writing 0x02 to AES0DCFG.
 - Write key size to bits 1 and 0 of AES0BCFG.
 - Configure the AES core for decryption by setting bit 2 of AES0BCFG.
 - Enable the AES core by setting bit 3 of AES0BCFG.
- Repeat alternating write sequence 16 times
 - Write plaintext byte to AES0BIN.
 - Write encryption key byte to AES0KIN.
- Write remaining encryption key bytes to AES0KIN for 192-bit and 256-bit decryption only.
- Wait on AES done interrupt or poll bit 5 of AES0BCFG.
- Repeat alternating write read sequence 16 times
 - Write initialization vector to AES0XIN
 - Read decrypted data from AES0YOUT

If decrypting multiple blocks, this process may be repeated. It is not necessary reconfigure the AES module for each block. When using Cipher Block Chaining the initialization vector is written to AES0XIN for the first block only, as described. Additional blocks will chain the ciphertext data from the previous block.

14.6.5. Counter Mode

The Counter (CTR) Mode uses a sequential counter which is incremented after each block. This turns the block cipher into a stream cipher. This algorithm is shown in Figure 14.4. Note that the decryption operation actually uses the encryption key and encryption block cipher. The XOR operation is always on the output of the cipher. The counter is a 16-byte block. Often, several bytes of the counter are initialized to a nonce (number used once). The last byte of the counter is incremented and propagated. Thus, the counter is treated as a 16-byte big endian integer.

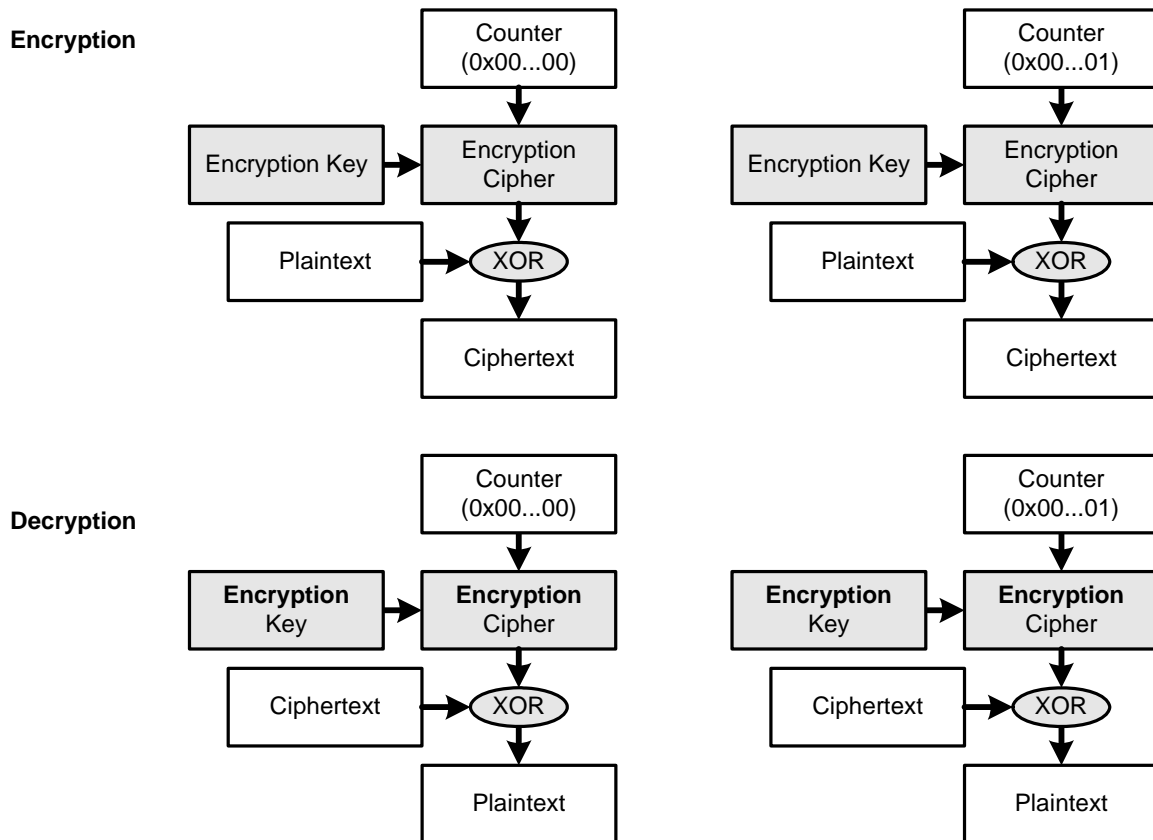

Figure 14.7. Counter Mode

Si102x/3x

14.6.5.1. CTR Data Flow

The AES0 module data flow for CTR encryption and decryption shown in Figure 14.5. The data flow is the same for encryption and decryption. AES0DCFG is always configured to XOR AES0XIN with the AES core output. The XOR on the input is not used. The AES core is configured for an encryption operation. The encryption key is written to AES0KIN. The key size is set to the desired key size.

For an encryption operation, the plaintext is written to AES0BIN and the ciphertext is read from AES0YOUT. For decryption, the ciphertext is written to AES0BIN and the plaintext is read from AES0YOUT.

Note the counter must be incremented after each block using software.

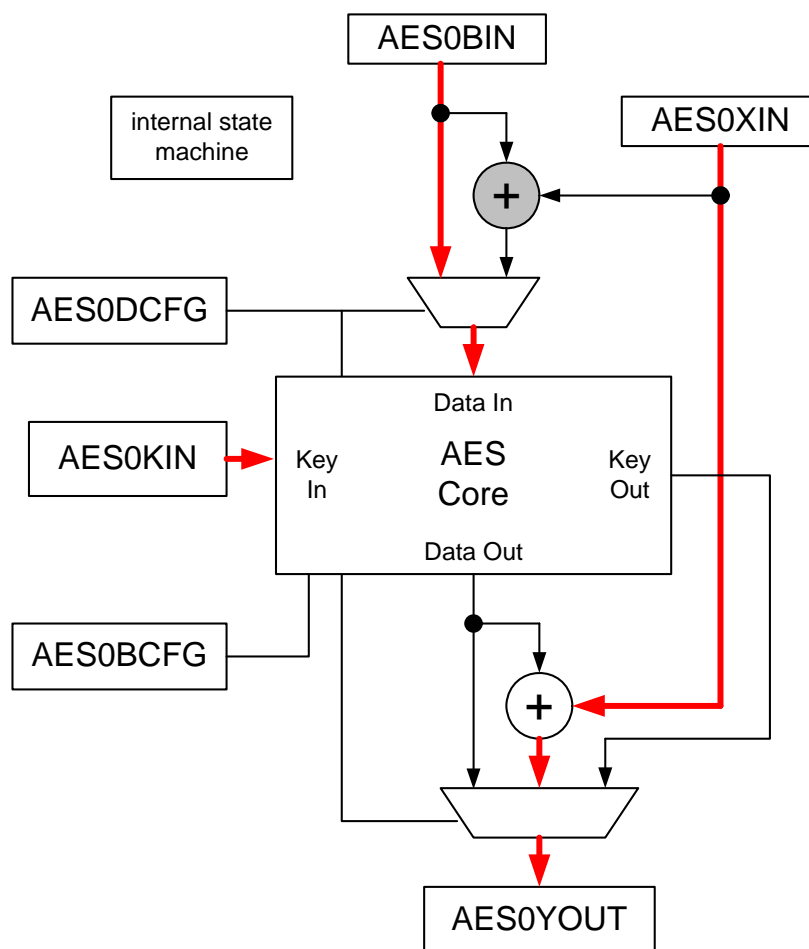

Figure 14.8. Counter Mode Data Flow

14.6.6. CTR Encryption using DMA

Normally, the AES block is used with the DMA. This provides the best performance and lowest power consumption. Code examples are provided in 8051 compiler independent C code using the DMA. It is highly recommended to use the code examples. The steps are listed here for completeness.

- Prepare encryption key, counter, and data to be encrypted in XRAM.
- Reset the AES module by clearing bit 2 of AES0BCFG.
- Disable the first four DMA channels by clearing bits 0 to 3 in DMA0EN.
- Configure the first DMA channel for AES0KIN
 - Select the first DMA channel by writing 0x00 to DMA0SEL
 - Configure the first DMA channel to move XRAM to AES0KIN by writing 0x05 to DMA0NCF
 - Clear DMA0NMD to disable wrapping.
 - Write the XRAM location of the encryption key to DMA0NBAH and DMA0NBAL.
 - Write the key length in bytes to DMA0NSZL
 - Clear DMA0NSZH
 - Clear DMA0NAOH and DMA0NAOL
- Configure the second DMA channel for AES0BIN.
 - Select the second DMA channel by writing 0x01 to DMA0SEL.
 - Configure the second DMA channel to move xram to AES0BIN sfr by writing 0x06 to the DMA0NCF sfr.
 - Clear DMA0NMD to disable wrapping.
 - Write the XRAM address of the data to be encrypted to DMA0NBAH and DMA0NBAL.
 - Write the number of bytes to be encrypted in multiples of 16 bytes to DMA0NSZH and DMA0NSZL
 - Clear the DMA0NSZH sfr
 - Clear the DMA0NAOH and DMA0NAOL sfrs.
- Configure the third DMA channel for the AES0XIN sfr.
 - Select the third DMA channel by writing 0x02 to DMA0SEL.
 - Configure the third DMA channel to move XRAM to AES0XIN by writing 0x07 to DMA0NCF.
 - Clear DMA0NMD to disable wrapping.
 - Write the XRAM address of the counter to DMA0NBAH and DMA0NBAL.
 - Write the number of bytes to be encrypted in multiples of 16 bytes to DMA0NSZH and DMA0NSZL.
 - Clear DMA0NAOH and DMA0NAOL.
- Configure the fourth DMA channel for AES0YOUT
 - Select the fourth channel by writing 0x03 to DMA0SEL
 - Configure the forth DMA channel to move the contents of AES0YOUT to XRAM by writing 0x08 to DMA0NCF
 - Enable transfer complete interrupt by setting bit 7 of DMA0NCF
 - Clear DMA0NMD to disable wrapping
 - Write the number of bytes to be encrypted in multiples of 16 bytes to DMA0NSZH and DMA0NSZL.
 - Clear DMA0NAOH and DMA0NAOL.
- Clear first four DMA interrupts by clearing bits 0 to 3 in DMA0INT.
- Enable first four DMA channels setting bits 0 to 3 in DMA0EN.
- Configure the AES module data flow for XOR on output data by writing 0x02 to AES0DCFG.
- Write key size to bits 1 and 0 of AES0BCFG
- Configure the AES core for encryption by setting bit 2 of AES0BCFG
- Initiate the encryption operation be setting bit 3 of AES0BCFG
- Wait on the DMA interrupt from DMA channel 3
- Disable the AES Module by clearing bit 2 of AES0BCFG
- Disable the DMA by writing 0x00 to DMA0EN
- Increment counter and repeat all steps for additional blocks

14.6.6.1. CTR Encryption using SFRs

- First Configure AES module for CTR encryption
 - Reset the AES module by writing 0x00 to AES0BCFG.
 - Configure the AES module data flow for XOR on output data by writing 0x02 to AES0DCFG.
 - Write key size to bits 1 and 0 of AES0BCFG.
 - Configure the AES core for encryption by setting bit 2 of AES0BCFG.
 - Enable the AES core by setting bit 3 of AES0BCFG.
- Repeat alternating write sequence 16 times
 - Write plaintext byte to AES0BIN.
 - Write counter byte to AES0XIN
 - Write encryption key byte to AES0KIN.
- Write remaining encryption key bytes to AES0KIN for 192-bit and 256-bit decryption only.
- Wait on AES done interrupt or poll bit 5 of AES0BCFG.
- Read 16 encrypted bytes from AES0YOUT.

If encrypting multiple blocks, increment the counter and repeat this process. It is not necessary reconfigure the AES module for each block.

SFR Definition 14.1. AES0BCFG: AES Block Configuration

Bit	7	6	5	4	3	2	1	0
Name			DONE	BUSY	EN	ENC	KSIZE	
Type	R	R	R/W	R	R/W	R/W	R/W	
Reset	0	0	0	0	0	0	0	0

SFR Address = 0xE9; SFR page = 0x2; Not bit-Addressable

Bit	Name	Function
5	DONE	<p>Done Flag.</p> <p>This bit is set upon completion of an encryption operation. When used with the DMA, the DONE bit signals the start of the out transfer. When used without the DMA, the done flag indicates data is ready to be read from AES0YOUT. The DONE bit is not cleared by hardware and must be cleared to zero by software at the start of the next encryption operation.</p>
4	BUSY	<p>AES BUSY.</p> <p>This bit is set while the AES block is engaged in an encryption or decryption operation. This bit is read only.</p>
3	EN	<p>AES Enable.</p> <p>This bit should be set to 1 to initiate an encryption or decryption operation. Clearing this bit to 0 will reset the AES module.</p>
2	ENC	<p>Encryption/Decryption Select.</p> <p>This is set to 1 to select an encryption operation. Clearing this bit to 0 will select a decryption operation.</p>
1:0	SIZE[1:0]	<p>AES Key Size.</p> <p>These bits select the key size for encryption/decryption.</p> <p>00: 128-bits (16-bytes) 01: 198-bits (24-bytes) 10: 256-bits (32-bytes) 11: Reserved</p>

Si102x/3x

SFR Definition 14.2. AES0DCFG: AES Data Configuration

Bit	7	6	5	4	3	2	1	0
Name						OUTSEL[1:0]		XORIN
Type	R	R	R	R	R	R/W		R/W
Reset	0	0	0	0	0	0	0	0

SFR Address = 0xEA; SFR page = 0x2; Not bit-Addressable

Bit	Name	Function
2:1	OUTSEL[1:0]	DATA Select. These bits select the output data source for the AES0YOUT sfr. 00: Direct AES Data 01: AES Data XOR with AES0XIN 10: Inverse Key 11: reserved
0	XORIN	XOR Input Enable. Setting this bit with enable the XOR data path on the AES input. If enabled, AES0BIN will be XORed with the AES0XIN and the results will feed into the AES data input. Clearing this bit to 0 will disable the XOR gate on the input. The contents of AES0BIN will go directly into the AES data input.

SFR Definition 14.3. AES0BIN: AES Block Input

Bit	7	6	5	4	3	2	1	0
Name	AES0BIN[7:0]							
Type	R/W	R/W	R/W	R/W	R/W	R/W	R/W	R/W
Reset	0	0	0	0	0	0	0	0

SFR Address = 0xEB; SFR page = 0x2; Not bit-Addressable

Bit	Name	Function
7:0	AES0BIN[7:0]	<p>AES Block Input.</p> <p>During an encryption operation, the plaintext is written to the AES0BIN sfr. During an decryption operation, the ciphertext is written to the AES0BIN sfr. During a key inversion the encryption key is written to AES0BIN.</p> <p>When used with the DMA, the DMA will write directly to this sfr.</p> <p>The AES0BIN may be used in conjunction with the AES0XIN sfr for some cipher block modes.</p> <p>When used without the DMA, AES0BIN, AES0XIN, and AES0KIN must be written in sequence.</p> <p>Reading this register will yield the last value written. This can be used for debug purposes.</p>

SFR Definition 14.4. AES0XIN: AES XOR Input

Bit	7	6	5	4	3	2	1	0
Name	AES0XIN[7:0]							
Type	R/W	R/W	R/W	R/W	R/W	R/W	R/W	R/W
Reset	0	0	0	0	0	0	0	0

SFR Address = 0xEC; SFR page = 0x2; Not bit-Addressable

Bit	Name	Function
7:0	AES0XIN[7:0]	<p>AES XOR Input.</p> <p>The AES0XIN may be used in conjunction with the AES0BIN sfr for some cipher block modes.</p> <p>When used with the DMA, the DMA will write directly to this sfr.</p> <p>When used without the DMA - AES0BIN, AES0XIN, and AES0KIN must be written in sequence.</p> <p>Reading this register will yield the last value written. This can be used for debug purposes.</p>

SFR Definition 14.5. AES0KIN: AES Key Input

Bit	7	6	5	4	3	2	1	0
Name	AES0KIN[7:0]							
Type	R/W	R/W	R/W	R/W	R/W	R/W	R/W	R/W
Reset	0	0	0	0	0	0	0	0

SFR Address = 0xED; SFR page = 0x2; Not bit-Addressable

Bit	Name	Function
7:0	AES0KIN[7:0]	<p>AES Key Input.</p> <p>During an encryption operation, the plaintext is written to the AES0BIN sfr. During an decryption operation, the ciphertext is written to the AES0BIN sfr. During a key inversion the encryption key is written to AES0BIN.</p> <p>When used with the DMA, the DMA will write directly to this sfr.</p> <p>The AES0BIN may be used in conjunction with the AES0XIN sfr for some cipher block modes.</p> <p>When used without the DMA - AES0BIN, AES0XIN, and AES0KIN must be written in sequence.</p>

SFR Definition 14.6. AES0YOUT: AES Y Output

Bit	7	6	5	4	3	2	1	0
Name	AES0YOUT[7:0]							
Type	R	R	R	R	R	R	R	R
Reset	0	0	0	0	0	0	0	0

SFR Address = 0xF5; SFR page = 0x2; Not bit-Addressable

Bit	Name	Function
7:0	AES0YOUT[7:0]	<p>AES Y Output.</p> <p>Upon completion of an encryption/decryption operation The output data may be read, one byte at a time, from the AES0YOUT SFR.</p> <p>When used with the DMA, the DMA will read directly from this SFR.</p> <p>The AES0YOUT SFR may be used in conjunction with the AES0XIN SFR for some cipher block modes.</p> <p>When used without the DMA, the firmware should wait on the DONE flag before reading from the AES0YOUT SFR.</p> <p>When used without the DMA and using XOR on the output, one byte should be written to AES0XIN before reading each byte from AES0YOUT.</p> <p>Reading this register over the C2 interface will not increment the output data.</p>

15. Encoder/Decoder

The Encoder/Decoder consists of three 8-bit data registers, a control register and an encoder/decoder logic block.

The size of the input data depends on the mode. The input data for Manchester encoding is one byte. For Manchester decoding it is two bytes. Three-out-of-Six encoding is two bytes. Three-out-of-six decoding is three bytes.

The output size also depends on the mode selected. The input and output data size are shown below:

Table 15.1. Encoder Input and Output Data Sizes

	Input Data Size	Output Data Size
Operation	Bytes	Bytes
Manchester Encode	1	2
Manchester Decode	2	1
Three out of Six Encode	2	3
Three out of Six Decode	3	2

The input and output data is always right justified. So for Manchester mode the input uses only ENC0L and the output data is only in ENC0M and ENC0L. ENC0H is not used for Manchester mode

15.1. Manchester Encoding

To encode Manchester Data, first clear the MODE bit for Manchester encoding or decoding.

To encode, one byte of data is written to the data register ENC0L.

Setting the ENC bit will initiate encoding. After encoding, the encoded data will be in ENC0M and ENC0L. The upper nibble of the input data is encoded and placed in ENC0M. The lower nibble is encoded and placed in ENC0L.

Note that the input data should be readable in the data register until the encode bit is set. Once the READY bit is set, the input data has been replaced by the output data.

The ENC and DEC bits are self clearing. The READY bit is not cleared by hardware and must be cleared manually. The control register does not need to be bit addressable. The READY bit can be cleared while setting the ENC or DEC bit using a direct or immediate SFR mov instruction.

Table 15.2. Manchester Encoding

Input Data			Encoded Output		
nibble			byte		
dec	hex	bin	bin	hex	dec
0	0	0000	10101010	AA	170
1	1	0001	10101001	A9	169
2	2	0010	10100110	A6	166
3	3	0011	10100101	A5	165
4	4	0100	10011010	9A	154
5	5	0101	10011001	99	153
6	6	0110	10010110	96	150
7	7	0111	10010101	95	149
8	8	1000	01101010	6A	106
9	9	1001	01101001	69	105
10	A	1010	01100110	66	102
11	B	1011	01100101	65	101
12	C	1100	01011010	5A	90
13	D	1101	01011001	59	89
14	E	1110	01010110	56	86
15	F	1111	01010101	55	85

15.2. Manchester Decoding

Two bytes of Manchester data are written to ENC0M and ENC0L sfrs. Then the DEC bit is set to initiate decoding. After decoding the READY bit will be set. If the data is not a valid encoded Manchester data, the ERROR bit will be set, and the output will be all FFs.

The encoding and decoding process should be symmetric. Data can be written to the ENC0L sfr, then encoded, then decoding will give the original data.

Table 15.3. Manchester Decoding

Input			Decoded Output		
Byte			Nibble		
bin	hex	dec	dec	hex	bin
01010101	55	85	15	F	1111
01010110	56	86	14	E	1110
01011001	59	89	13	D	1101
01011010	5A	90	12	C	1100
01100101	65	101	11	B	1011
01100110	66	102	10	A	1010
01101001	69	105	9	9	1001
01101010	6A	106	8	8	1000
10010101	95	149	7	7	0111
10010110	96	150	6	6	0110
10011001	99	153	5	5	0101
10011010	9A	154	4	4	0100
10100101	A5	165	3	3	0011
10100110	A6	166	2	2	0010
10101001	A9	169	1	1	0001
10101010	AA	170	0	0	0000

15.3. Three-out-of-Six Encoding

Three out of six encoding is similar to Manchester encoding. In Three-out-of-Six encoding a nibble is encoded as a six-bit symbol. Four nibbles are encoded as 24-bits (three bytes).

Two bytes of data to be encoded are written to ENC0M and ENC0L. The MODE bit is set to 1 for Three-out-of-Six encoding. Setting the ENC bit will initiate encoding.

After encoding, the three encoded bytes are in ENC2-0.

Table 15.4. Three-out-of-Six Encoding Nibble

Input			Encoded Output			
nibble			symbol			
dec	hex	bin	bin	dec	hex	octal
0	0	0000	010110	22	16	26
1	1	0001	001101	13	0D	15
2	2	0010	001110	14	0E	16
3	3	0011	001011	11	0B	13
4	4	0100	011100	28	1C	34
5	5	0101	011001	25	19	31
6	6	0110	011010	26	1A	32
7	7	0111	010011	19	13	23
8	8	1000	101100	44	2C	54
9	9	1001	100101	37	25	45
10	A	1010	100110	38	26	46
11	B	1011	100011	35	23	43
12	C	1100	110100	52	34	64
13	D	1101	110001	49	31	61
14	E	1110	110010	50	32	62
15	F	1111	101001	41	29	51

15.4. Three-out-of-Six Decoding

Three-out-of-Six decoding is a similar inverse process. Three bytes of encoded data are written to ENC2-0. The DEC bit is set to initiate decoding. The READY bit will be set when decoding is complete. The ERROR bit will be set if the input data is not valid Three-out-of-Six data.

The Three-out-of-Six encoder decode process is also symmetric. Two bytes of arbitrary data may be written to ENC0M-ENC0L, then encoded, then decoding will yield the original data.

Table 15.5. Three-out-of-Six Decoding

Input			Decoded Output		
Symbol			Nibble		
bin	octal	dec	dec	hex	bin
001011	13	11	3	3	0011
001101	15	13	1	1	0001
001110	16	14	2	2	0010
010011	23	19	7	7	0111
010110	26	22	0	0	0000
011001	31	25	5	5	0101
011010	32	26	6	6	0110
011100	34	28	4	4	0100
100011	43	35	11	B	1011
100101	45	37	9	9	1001
100110	46	38	10	A	1010
101001	51	41	15	F	1111
101100	54	44	8	8	1000
110001	61	49	13	D	1101
110010	62	50	14	E	1110
110100	64	52	12	C	1100

15.5. Encoding/Decoding with SFR Access

The steps to perform a Encode/Decode operation using SFR access with the ENC0 module are as follow:

1. Clear ENC0CN by writing 0x00.
2. Write the input data to ENC0H:M:L.
3. Write the operation value to ENC0CN setting ENC, DEC, and MODE bits as desired and clearing all other bits.
 - a. Write 0x10 for Manchester Decode operation.
 - b. Write 0x11 for Three-out-of-Six Decode operation.
 - c. Write 0x20 for Manchester Encode operation.
 - d. Write 0x21 for Three-out-of-Six Encode operation.
4. Wait on the READY bit in ENC0CN.
5. For a decode operation only, check the ERROR bit in ENC0CN for a decode error.
6. Read the results from ENC0H:M:L.
7. Repeat steps 2-6 for all remaining data.

Note that all of the ENC0 SFRs are on SFR page 0x2. The READY and ERROR must be cleared in ENC0CN with each operation.

15.6. Decoder Error Interrupt

The Encoder/Decoder peripheral is capable of generating an interrupt on a decoder error. Normally, when used with the DMA, the DMA will transfer the entire specified transfer size to and from the Encoder/Decoder peripheral. If a decoder error occurs, decoding will continue until all data has been decoded. The error bit in the ENC0CN SFR will indicate if an error has occurred anywhere in the DMA transfer. Some applications will discard the entire packet after a single decoder error. Aborting the decoder operation at the first decoder error will conserve energy and minimize packet receiver turn-around time. The decoder interrupt service routine should first stall the ENC0 DMA channels by selecting the ENC0 DMA channels and then setting the STALL bit. Then disable the DMA channels by clearing the relevant DMA0EN bits. In addition, clear any ENC DMA channel interrupts by clearing the respective bits in DMA0NINT.

15.7. Using the ENC0 module with the DMA

The steps for Encoding/Decoding using the DMA are as follows.

1. Clear the ENC module by writing 0x00 to the ENC0CN SFR.
2. Configure the first DMA channel for the XRAM-to-ENC0 input transfer:
 - a. Disable the first DMA channel by clearing the corresponding bit in DMA0EN.
 - b. Select the first DMA channel by writing to DMA0SEL.
 - c. Configure the selected DMA channel to use the XRAM-to-ENC0 input peripheral request by writing 0x00 to DMA0NCF.
 - d. Set the ENDIAN bit in DMA0NCF to enable big-endian multi-byte DMA transfers.
 - e. Write 0 to DMA0NMD to disable wrapping.
 - f. Write the address of the first byte of input data DMA0NBAH:L.
 - g. Write the size of the input data transfer in bytes to DMA0NSZH:L.
 - h. Clear the address offset SFRs DMA0A0H:L.
3. Configure the second DMA channel for the ENC0-to-XRAM output transfer:
 - a. Disable the second DMA channel by clearing the corresponding bit in DMA0EN.
 - b. Select the second DMA channel by writing to DMA0SEL.
 - c. Configure the selected DMA channel to use the SPI1DAT-to-XRAM output peripheral request by writing 0x01 to DMA0NCF.
 - d. Set the ENDIAN bit in DMA0NCF to enable big-endian multi-byte DMA transfers.
 - e. Enable DMA interrupts for the second channel by setting bit 7 of DMA0NCF.
 - f. Write 0 to DMA0NMD to disable wrapping.
 - g. Write the address for the first byte of the output data to DMA0NBAH:L.
 - h. Write the size of the output data transfer in bytes to DMA0NSZH:L.
 - i. Clear the address offset SFRs DMA0A0H:L.
 - j. Enable the interrupt on the second channel by setting the corresponding bit in DMA0INT.
4. Clear the interrupt bits in DMA0INT for both channels.
5. Enable DMA interrupts by setting bit 5 of EIE2.
6. If desired for a decode operation, enable the ERROR interrupt bit by setting bit 6 of EIE2.
7. Write the operation value to ENC0CN setting ENC, DEC, and MODE bits for the desired operation. The DMA bit and ENDIAN bits must be set. The READY bits and ERROR bits must be cleared.
 - a. Write 0x16 for Manchester Decode operation.
 - b. Write 0x17 for Three-out-of-Six Decode operation.
 - c. Write 0x26 for Manchester Encode operation.
 - d. Write 0x27 for Three-out-of-Six Encode operation.
8. Wait on the DMA interrupt.
9. Clear the DMA enables in the DMA0EN SFR.
10. Clear the DMA interrupts in the DMA0INT SFR.
11. For a decode operation only, check the ERROR bit in ENC0CN for a decode error.

Note that the encoder and all DMA channels should be configured for Big-Endian mode.

SFR Definition 15.1. ENC0CN: Encoder Decoder 0 Control

Bit	7	6	5	4	3	2	1	0
Name	READY	ERROR	ENC	DEC		DMA	ENDIAN	MODE
Type	R	R	R/W	R/W	R	R/W	R/W	R/W
Reset	0	0	0	0	0	0	0	0

SFR Address = 0xC5; SFR page = 0x2; Not bit-Addressable

Bit	Name	Function
7	READY	Ready Flag.
6	ERROR	Error Flag.
5	ENC	Encode. Setting this bit will initiate an Encode operation.
4	DEC	Decode. Setting this bit will initiate a Decode operation.
2	DMA	DMA Mode Enable. This bit should be set when using the encoder/decoder with the DMA.
1	ENDIAN	Big-Endian DMA Mode Select. This bit should be set when using the DMA with big-endian multiple byte DMA transfers. The DMA must also be configured for the same endian mode.
0	MODE	Mode. 0: Select Manchester encoding or decoding. 1: Select Three-out-of-Six encoding or decoding.

Si102x/3x

SFR Definition 15.2. ENC0L: ENC0 Data Low Byte

Bit	7	6	5	4	3	2	1	0
Name	ENC0L[7:0]							
Type	R/W	R/W	R/W	R/W	R/W	R/W	R/W	R/W
Reset	0	0	0	0	0	0	0	0

SFR Page = 0x2; SFR Address = 0xC2; Bit-Addressable

Bit	Name	Function
7:0	ENC0L[7:0]	ENC0 Data Low Byte.

SFR Definition 15.3. ENC0M: ENC0 Data Middle Byte

Bit	7	6	5	4	3	2	1	0
Name	ENC0M[7:0]							
Type	R/W	R/W	R/W	R/W	R/W	R/W	R/W	R/W
Reset	0	0	0	0	0	0	0	0

SFR Page = 0x2; SFR Address = 0xC3; Bit-Addressable

Bit	Name	Function
7:0	ENC0M[7:0]	ENC0 Data Middle Byte.

SFR Definition 15.4. ENC0H: ENC0 Data High Byte

Bit	7	6	5	4	3	2	1	0
Name	ENC0H[7:0]							
Type	R/W	R/W	R/W	R/W	R/W	R/W	R/W	R/W
Reset	0	0	0	0	0	0	0	0

SFR Page = 0x2; SFR Address = 0xC4; Bit-Addressable

Bit	Name	Function
7:0	ENC0H[7:0]	ENC0 Data High Byte.

16. Special Function Registers

The direct-access data memory locations from 0x80 to 0xFF constitute the special function registers (SFRs). The SFRs provide control and data exchange with the Si102x/3x's resources and peripherals. The CIP-51 controller core duplicates the SFRs found in a typical 8051 implementation as well as implementing additional SFRs used to configure and access the sub-systems unique to the Si102x/3x. This allows the addition of new functionality while retaining compatibility with the MCS-51™ instruction set. Table 16.3 lists the SFRs implemented in the Si102x/3x device family.

The SFR registers are accessed anytime the direct addressing mode is used to access memory locations from 0x80 to 0xFF. SFRs with addresses ending in 0x0 or 0x8 (e.g., P0, TCON, SCON0, IE, etc.) are bit-addressable as well as byte-addressable. All other SFRs are byte-addressable only. Unoccupied addresses in the SFR space are reserved for future use. Accessing unoccupied addresses in the SFR space will have an indeterminate effect and should be avoided. Refer to the corresponding pages of the data sheet, as indicated in Table 16.3, for a detailed description of each register.

16.1. SFR Paging

The CIP-51 features SFR paging, allowing the device to map many SFRs into the 0x80 to 0xFF memory address space. The SFR memory space has 256 *pages*. In this way, each memory location from 0x80 to 0xFF can access up to 256 SFRs. The Si102x/3x family of devices utilizes two SFR pages: 0x00 and 0x0F. SFR pages are selected using the Special Function Register Page Selection register, SFRPAGE (see SFR Definition 11.3). The procedure for reading and writing an SFR is as follows:

1. Select the appropriate SFR page number using the SFRPAGE register.
2. Use direct accessing mode to read or write the special function register (MOV instruction).

16.2. Interrupts and SFR Paging

When an interrupt occurs, the current SFRPAGE is pushed onto the SFR page stack. Upon execution of the RETI instruction, the SFR page is automatically restored to the SFR Page in use prior to the interrupt. This is accomplished via a three-byte *SFR Page Stack*. The top byte of the stack is SFRPAGE, the current SFR Page. The second byte of the SFR Page Stack is SFRNEXT. The third, or bottom byte of the SFR Page Stack is SFRLAST. Upon an interrupt, the current SFRPAGE value is pushed to the SFRNEXT byte, and the value of SFRNEXT is pushed to SFRLAST. On a return from interrupt, the SFR Page Stack is popped resulting in the value of SFRNEXT returning to the SFRPAGE register, thereby restoring the SFR page context without software intervention. The value in SFRLAST (0x00 if there is no SFR Page value in the bottom of the stack) of the stack is placed in SFRNEXT register. If desired, the values stored in SFRNEXT and SFRLAST may be modified during an interrupt, enabling the CPU to return to a different SFR Page upon execution of the RETI instruction (on interrupt exit). Modifying registers in the SFR Page Stack does not cause a push or pop of the stack. Only interrupt calls and returns will cause push/pop operations on the SFR Page Stack.

On the Si102x/3x devices, the SFRPAGE must be explicitly set in the interrupt service routine.

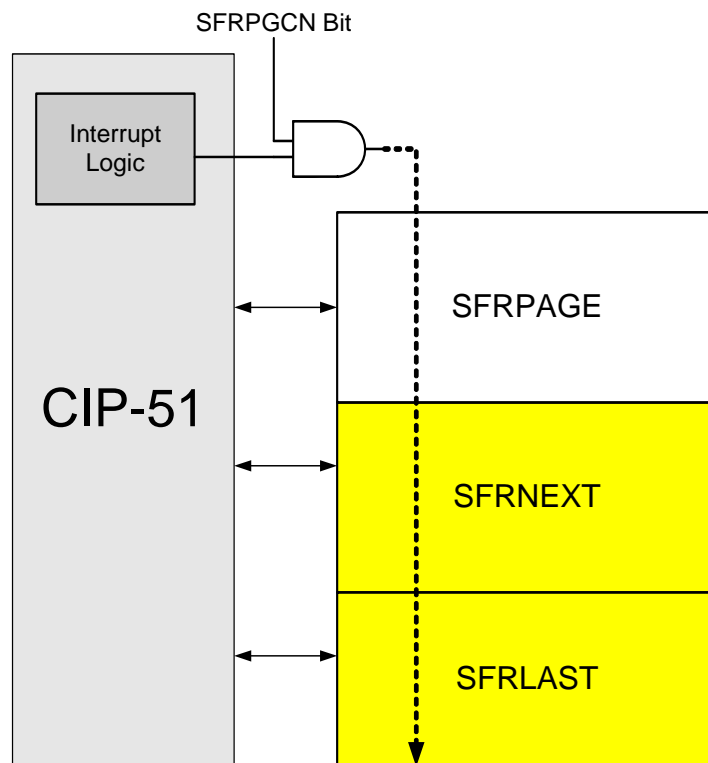

Figure 16.1. SFR Page Stack

Automatic hardware switching of the SFR Page on interrupts may be enabled or disabled as desired using the SFR Automatic Page Control Enable Bit located in the SFR Page Control Register (SFR0CN). This function defaults to “enabled” upon reset. In this way, the autoswitching function will be enabled unless disabled in software.

A summary of the SFR locations (address and SFR page) are provided in Table 16.3 in the form of an SFR memory map. Each memory location in the map has an SFR page row, denoting the page in which that SFR resides. Certain SFRs are accessible from ALL SFR pages, and are denoted by the “(ALL PAGES)” designation. For example, the Port I/O registers P0, P1, P2, and P3 all have the “(ALL PAGES)” designation, indicating these SFRs are accessible from all SFR pages regardless of the SFRPAGE register value.

16.3. SFR Page Stack Example

The following is an example that shows the operation of the SFR Page Stack during interrupts. In this example, the SFR Control register is left in the default enabled state (i.e., SFRPGEN = 1), and the CIP-51 is executing in-line code that is writing values to SMBus Address Register (SFR “SMB0ADR”, located at address 0xF4 on SFR Page 0x0). The device is also using the SPI peripheral (SPI0) and the Programmable Counter Array (PCA0) peripheral to generate a PWM output. The PCA is timing a critical control function in its interrupt service routine, and so its associated ISR is set to high priority. At this point, the SFR page is set to access the SMB0ADR SFR (SFRPAGE = 0x0). See Figure 16.2.

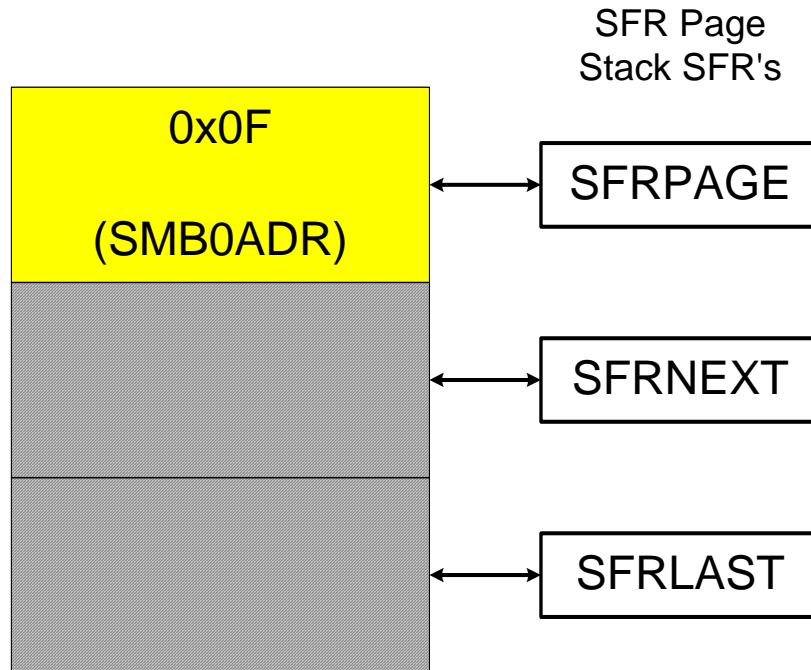

Figure 16.2. SFR Page Stack While Using SFR Page 0x0 To Access SMB0ADR

While CIP-51 executes in-line code (writing a value to SMB0ADR in this example), the SPI0 Interrupt occurs. The CIP-51 vectors to the SPI0 ISR and pushes the current SFR Page value (SFR Page 0x0F) into SFRNEXT in the SFR Page Stack. SFRPAGE is considered the “top” of the SFR Page Stack. Software may switch to any SFR Page by writing a new value to the SFRPAGE register at any time during the SPI0 ISR. See Figure 16.3.

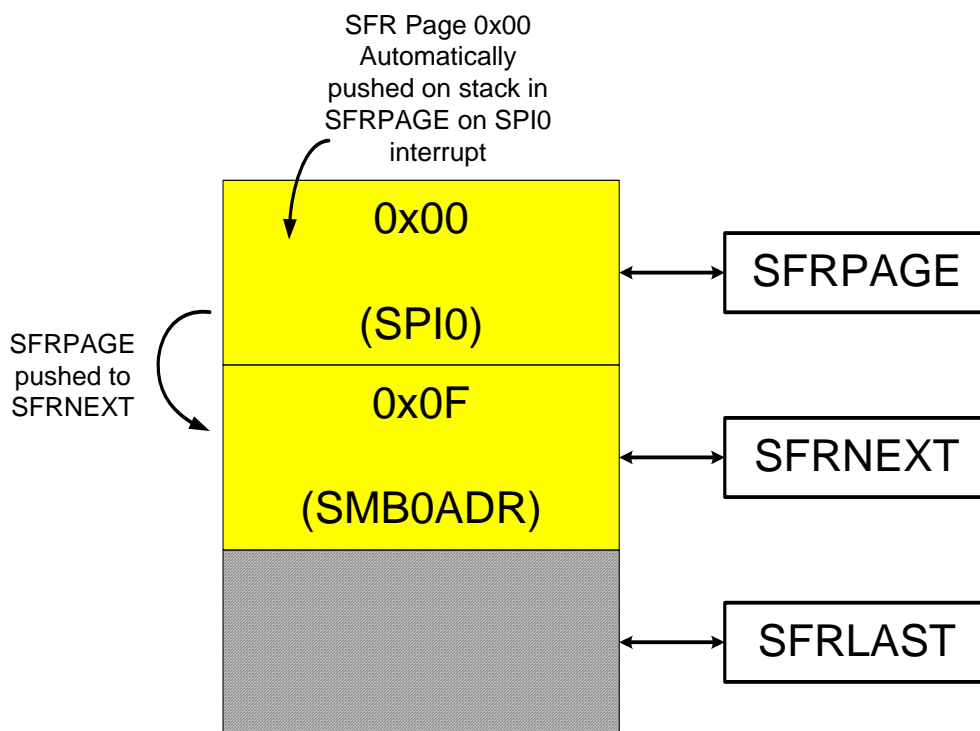

Figure 16.3. SFR Page Stack After SPI0 Interrupt Occurs

While in the SPI0 ISR, a PCA interrupt occurs. Recall the PCA interrupt is configured as a high priority interrupt, while the SPI0 interrupt is configured as a *low* priority interrupt. Thus, the CIP-51 will now vector to the high priority PCA ISR. Upon doing so, the CIP-51 will automatically place the SFR page needed to access the PCA's special function registers into the SFRPAGE register, SFR Page All Pages. The value that was in the SFRPAGE register before the PCA interrupt (SFR Page 0x00 for SPI0) is pushed down the stack into SFRNEXT. Likewise, the value that was in the SFRNEXT register before the PCA interrupt (in this case SFR Page 0x0F for SMB0ADR) is pushed down to the SFRLAST register, the "bottom" of the stack. Note that a value stored in SFRLAST (via a previous software write to the SFRLAST register) will be overwritten. See Figure 16.4.

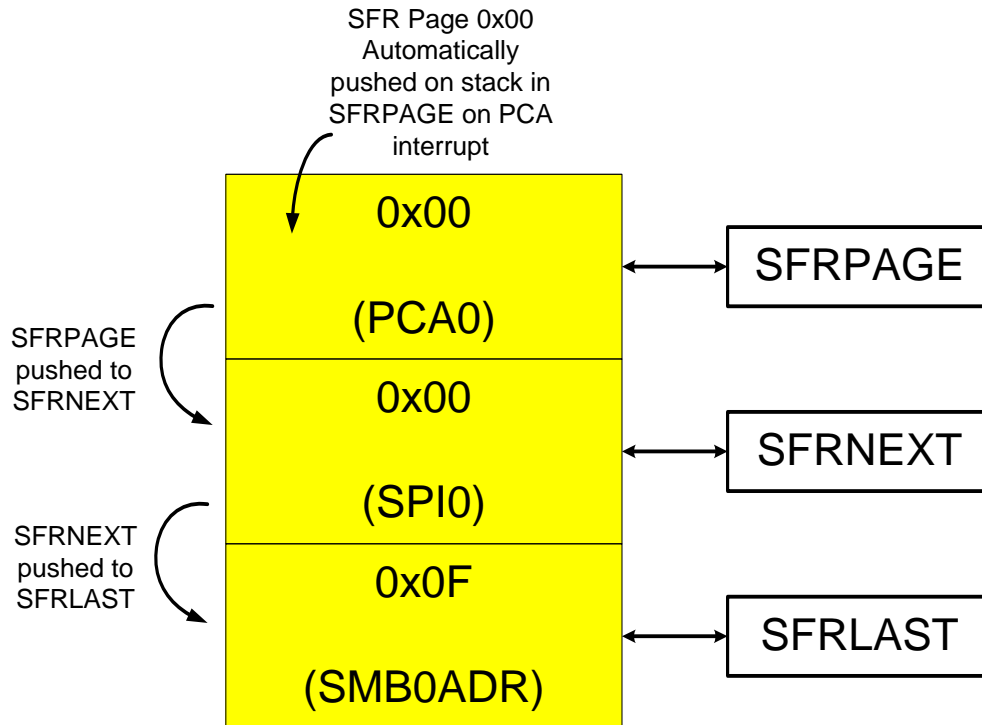

Figure 16.4. SFR Page Stack Upon PCA Interrupt Occurring During a SPI0 ISR

On exit from the PCA interrupt service routine, the CIP-51 will return to the SPI0 ISR. On execution of the RETI instruction, SFR Page All Pages used to access the PCA registers will be automatically popped off of the SFR Page Stack, and the contents of the SFRNEXT register will be moved to the SFRPAGE register. Software in the SPI0 ISR can continue to access SFRs as it did prior to the PCA interrupt. Likewise, the contents of SFRLAST are moved to the SFRNEXT register. Recall this was the SFR Page value 0x0F being used to access SMB0ADR before the SPI0 interrupt occurred. See Figure 16.5.

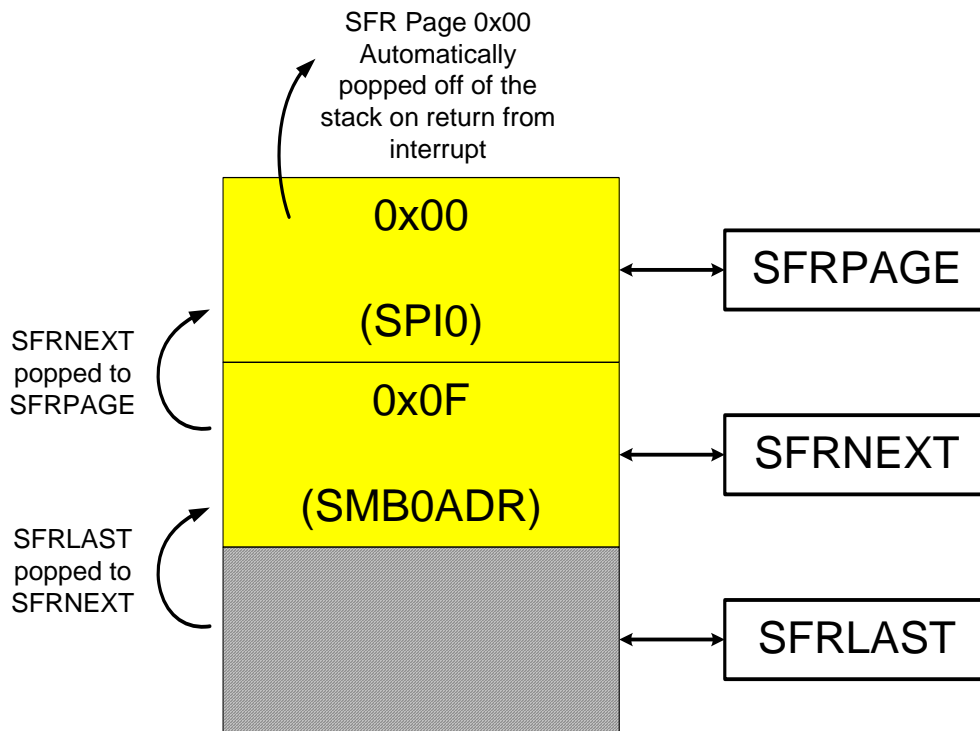

Figure 16.5. SFR Page Stack Upon Return From PCA Interrupt

On the execution of the RETI instruction in the SPI0 ISR, the value in SFRPAGE register is overwritten with the contents of SFRNEXT. The CIP-51 may now access the SMB0ADR register as it did prior to the interrupts occurring. See Figure 16.6.

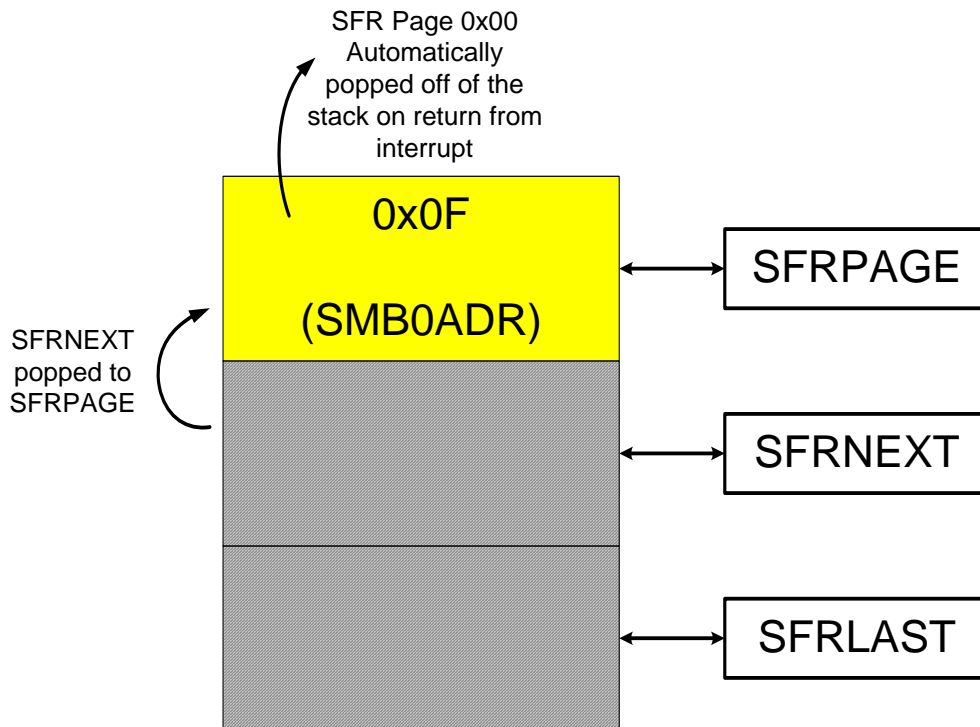

Figure 16.6. SFR Page Stack Upon Return From SPI0 Interrupt

In the example above, all three bytes in the SFR Page Stack are accessible via the SFRPAGE, SFRNEXT, and SFRLAST special function registers. If the stack is altered while servicing an interrupt, it is possible to return to a different SFR Page upon interrupt exit than selected prior to the interrupt call. Direct access to the SFR Page stack can be useful to enable real-time operating systems to control and manage context switching between multiple tasks.

Push operations on the SFR Page Stack only occur on interrupt service, and pop operations only occur on interrupt exit (execution on the RETI instruction). The automatic switching of the SFRPAGE and operation of the SFR Page Stack as described above can be disabled in software by clearing the SFR Automatic Page Enable Bit (SFRPGEN) in the SFR Page Control Register (SFR0CN). See SFR Definition 16.1.

SFR Definition 16.1. SFRPGCN: SFR Page Control

Bit	7	6	5	4	3	2	1	0
Name								SFRPGEN
Type	R	R	R	R	R	R	R	R/W
Reset	0	0	0	0	0	0	0	1

;SFR Page = 0xF; SFR Address = 0x8E

Bit	Name	Function
7:1	Unused	Read = 0000000b; Write = Don't Care
0	SFRPGEN	<p>SFR Automatic Page Control Enable.</p> <p>Upon interrupt, the C8051 Core will vector to the specified interrupt service routine and automatically switch the SFR page to the corresponding peripheral or function's SFR page. This bit is used to control this autopaging function.</p> <p>0: SFR Automatic Paging disabled. The C8051 core will not automatically change to the appropriate SFR page (i.e., the SFR page that contains the SFRs for the peripheral/function that was the source of the interrupt).</p> <p>1: SFR Automatic Paging enabled. Upon interrupt, the C8051 will switch the SFR page to the page that contains the SFRs for the peripheral or function that is the source of the interrupt.</p>

SFR Definition 16.2. SFRPAGE: SFR Page

Bit	7	6	5	4	3	2	1	0
Name	SFRPAGE[7:0]							
Type	R/W							
Reset	0	0	0	0	0	0	0	0

SFR Page = All Pages; SFR Address = 0xA7

Bit	Name	Function
7:0	SFRPAGE[7:0]	<p>SFR Page Bits.</p> <p>Represents the SFR Page the C8051 core uses when reading or modifying SFRs.</p> <p>Write: Sets the SFR Page.</p> <p>Read: Byte is the SFR page the C8051 core is using.</p> <p>When enabled in the SFR Page Control Register (SFR0CN), the C8051 core will automatically switch to the SFR Page that contains the SFRs of the corresponding peripheral/function that caused the interrupt, and return to the previous SFR page upon return from interrupt (unless SFR Stack was altered before a returning from the interrupt). SFRPAGE is the top byte of the SFR Page Stack, and push/pop events of this stack are caused by interrupts (and not by reading/writing to the SFRPAGE register)</p>

Si102x/3x

SFR Definition 16.3. SFRNEXT: SFR Next

Bit	7	6	5	4	3	2	1	0
Name	SFRNEXT[7:0]							
Type	R/W							
Reset	0	0	0	0	0	0	0	0

;SFR Page = All Pages; SFR Address = 0x85

Bit	Name	Function
7:0	SFRNEXT[7:0]	<p>SFR Page Bits.</p> <p>This is the value that will go to the SFR Page register upon a return from interrupt.</p> <p>Write: Sets the SFR Page contained in the second byte of the SFR Stack. This will cause the SFRPAGE SFR to have this SFR page value upon a return from interrupt.</p> <p>Read: Returns the value of the SFR page contained in the second byte of the SFR stack.</p> <p>SFR page context is retained upon interrupts/return from interrupts in a 3 byte SFR Page Stack: SFRPAGE is the first entry, SFRNEXT is the second, and SFRLAST is the third entry. The SFR stack bytes may be used alter the context in the SFR Page Stack, and will not cause the stack to “push” or “pop”. Only interrupts and return from interrupts cause pushes and pops of the SFR Page Stack.</p>

SFR Definition 16.4. SFRLAST: SFR Last

Bit	7	6	5	4	3	2	1	0
Name	SFRLAST[7:0]							
Type	R/W							
Reset	0	0	0	0	0	0	0	0

;SFR Page = All Pages; SFR Address = 0x86

Bit	Name	Function
7:0	SFRLAST[7:0]	<p>SFR Page Stack Bits.</p> <p>This is the value that will go to the SFRNEXT register upon a return from interrupt.</p> <p>Write: Sets the SFR Page in the last entry of the SFR Stack. This will cause the SFRNEXT SFR to have this SFR page value upon a return from interrupt.</p> <p>Read: Returns the value of the SFR page contained in the last entry of the SFR stack.</p> <p>SFR page context is retained upon interrupts/return from interrupts in a 3 byte SFR Page Stack: SFRPAGE is the first entry, SFRNEXT is the second, and SFRLAST is the third entry. The SFR stack bytes may be used alter the context in the SFR Page Stack, and will not cause the stack to “push” or “pop”. Only interrupts and return from interrupts cause pushes and pops of the SFR Page Stack.</p>

Table 16.1. SFR Map (0xC0–0xFF)

Addr.	Page	0(8)	1(9)	2(A)	3(B)	4(C)	5(D)	6(E)	7(F)
0xF8	0x0	SPI0CN	PCA0L	PCA0H	PCA0CPL0	PCA0CPH0	PCA0CPL4	PCA0CPH4	VDM0CN
	0x2	SPI1CN	PC0DCL	PC0DCH	PC0INT0	PC0INT1	DC0RDY		
	0xF		P4MDOUT	P5MDOUT	P6MDOUT	P7MDOUT	CLKMODE	PCLKEN	
0xF0	0x0		P0MDIN	P1MDIN	P2MDIN	SMB0ADR	SMB0ADM	EIP1	EIP2
	0x2		PC0CMP1L	PC0CMP1M	PC0CMP1H	PC0HIST	AES0YOUT		
	0xF		P3MDIN	P4MDIN	P5MDIN	P6MDIN	PCLKACT		
0xE8	0x0	ADC0CN	PCA0CPL1	PCA0CPH1	PCA0CPL2	PCA0CPH2	PCA0CPL3	PCA0CPH3	RSTSRC
	0x2		AES0BCFG	AES0DCFG	AES0BIN	AES0XIN	AES0KIN		
	0xF		DEVICEID	REVID					
0xE0	0x0	ACC	XBR0	XBR1	XBR2	IT01CF		EIE1	EIE2
	0x2		PC0CMP0L	PC0CMP0M	PC0CMP0H	PC0TH			
	0xF		XBR0	XBR1	XBR2	IT01CF			
0xD8	0x0	PCA0CN	PCA0MD	PCA0CPM0	PCA0CPM1	PCA0CPM2	PCA0CPM3	PCA0CPM4	PCA0PWM
	0x2		PC0MD	PC0CTR0L	PC0TRML	PC0CTR0H	PC0CTR1L	PC0TRMH	PC0CTR1H
	0xF		P4	P5	P6	P7			
0xD0	0x0	PSW	REF0CN	PCA0CPL5	PCA0CPH5	P0SKIP	P1SKIP	P2SKIP	P0MAT
	0x2		DMA0SEL	DMA0EN	DMA0INT	DMA0MINT	DMA0BUSY	DMA0NMD	PC0PCF
	0xF								
0xC8	0x0	TMR2CN	REG0CN	TMR2RLL	TMR2RLH	TMR2L	TMR2H	PCA0CPM5	P1MAT
	0x2		DMA0NCF	DMA0NBAL	DMA0NBAH	DMA0NAOL	DMA0NAOH	DMA0NSZL	DMA0NSZH
	0xF								
0xC0	0x0	SMB0CN	SMB0CF	SMB0DAT	ADC0GTL	ADC0GTH	ADC0LTL	ADC0LTH	P0MASK
	0x2		PC0STAT	ENC0L	ENC0M	ENC0H	ENC0CN	VREGINSDL	VREGINSDH
	0xF								

Table 16.2. SFR Map (0x80–0xBF)

Addr.	Page	0(8)	1(9)	2(A)	3(B)	4(C)	5(D)	6(E)	7(F)
0xB8	0x0	IP	IREF0CN	ADC0AC	ADC0MX	ADC0CF	ADC0L	ADC0H	P1MASK
	0x2		CRC1IN	CRC1OUTL	CRC1OUTH	CRC1POLL	CRC1POLH	CRC1CN	
	0xF		IREF0CF	ADC0PWR	ADC0TK		TOFFL	TOFFH	
0xB0	0x0	P3	OSCXCN	OSCICN	PMU0MD		PMU0CF	PMU0FL	FLKEY
	0x2		DC0CN	DC0CF	DC0MD		LCD0CHPCN	LCD0BUFMD	
	0xF		P3MDOUT	OSCIFL	OSCICL			FLSCL	
0xA8	0x0	IE	CLKSEL	EMI0CN	EMI0CF	RTC0ADR	RTC0DAT	RTC0KEY	EMI0TC
	0x2		LCD0CLKDIVL	LCD0CLKDIVH	LCD0MSCN	LCD0MSCF	LCD0CHPCF	LCD0CHPMD	LCD0VBMCF
	0xF		CLKSEL	P6DRV	P7DRV	LCD0BUFCF			
0xA0	0x0	P2	SPI0CFG	SPI0CKR	SPI0DAT	P0MDOUT	P1MDOUT	P2MDOUT	SFRPAGE
	0x2		SPI1CFG	SPI1CKR	SPI1DAT	LCD0PWR	LCD0CF	LCD0VBMCN	
	0xF		P3DRV	P4DRV	P5DRV	P0DRV	P1DRV	P2DRV	
0x98	0x0	SCON0	SBUF0	CPT1CN	CPT0CN	CPT1MD	CPT0MD	CPT1MX	CPT0MX
	0x2		LCD0DD	LCD0DE	LCD0DF	LCD0CNRST	LCD0CN	LCD0BLINK	LCD0TOGR
	0xF					LCD0BUFCN			
0x90	0x0	P1	TMR3CN	TMR3RLL	TMR3RLH	TMR3L	TMR3H		
	0x2		LCD0D6	LCD0D7	LCD0D8	LCD0D9	LCD0DA	LCD0DB	LCD0DC
	0xF		CRC0DAT	CRC0CN	CRC0IN	CRC0FLIP		CRC0AUTO	CRC0CNT
0x88	0x0	TCON	TMOD	TL0	TL1	TH0	TH1	CKCON	PSCTL
	0x2		LCD0D0	LCD0D1	LCD0D2	LCD0D3	LCD0D4	LCD0D5	
	0xF							SFRPGCN	
0x80	0x0	P0	SP	DPL	DPH	PSBANK	SFRNEXT	SFRLAST	PCON
	0x2								
	0xF								

Table 16.3. Special Function Registers

SFRs are listed in alphabetical order. All undefined SFR locations are reserved.

Register	Address	SFR Page	Description	Page
ADC0AC	0xBA	0x0	ADC0 Accumulator Configuration	88
ADC0CF	0xBC	0x0	ADC0 Configuration	87
ADC0CN	0xE8	All pages	ADC0 Control	86
ADC0GTH	0xC4	0x0	ADC0 Greater-Than Compare High	92
ADC0GTL	0xC3	0x0	ADC0 Greater-Than Compare Low	92
ADC0H	0xBE	0x0	ADC0 High	91
ADC0L	0xBD	0x0	ADC0 Low	91
ADC0LTH	0xC6	0x0	ADC0 Less-Than Compare Word High	93
ADC0LTL	0xC5	0x0	ADC0 Less-Than Compare Word Low	93
ADC0MX	0xBB	0x0	ADC0 MUX	96
ADC0PWR	0xBA	0xF	ADC0 Burst Mode Power-Up Time	89
ADC0TK	0xBB	0xF	ADC0 Tracking Control	90
AES0BCFG	0xE9	0x2	AES0 Block Configuration	203
AES0BIN	0xEB	0x2	AES0 Block Input	205
AES0DCFG	0xEA	0x2	AES0 Data Configuration	204
AES0KIN	0xED	0x2	AES0 Key Input	206
AES0XIN	0xEC	0x2	AES0 XOR Input	206
AES0YOUT	0xF5	0x2	AES Y Out	207
CKCON	0x8E	0x0	Clock Control	492
CLKMODE	0xFD	0xF	Clock Mode	269
CLKSEL	0xA9	0x0 and 0xF	Clock Select	298
CPT0CN	0x9B	0x0	Comparator0 Control	106
CPT0MD	0x9D	0x0	Comparator0 Mode Selection	107
CPT0MX	0x9F	0x0	Comparator0 Mux Selection	113
CPT1CN	0x9A	0x0	Comparator1 Control	108
CPT1MD	0x9C	0x0	Comparator1 Mode Selection	109
CPT1MX	0x9E	0x0	Comparator1 Mux Selection	114
CRC0AUTO	0x96	0xF	CRC0 Automatic Control	167
CRC0CNT	0x97	0xF	CRC0 Automatic Flash Sector Count	167
CRC0CN	0x92	0xF	CRC0 Control	165
CRC0DAT	0x91	0xF	CRC0 Data	166
CRC0FLIP	0x94	0xF	CRC0 Flip	168
CRC0IN	0x93	0xF	CRC0 Input	166

Table 16.3. Special Function Registers (Continued)

SFRs are listed in alphabetical order. All undefined SFR locations are reserved.

Register	Address	SFR Page	Description	Page
CRC1CN	0xBE	0x2	CRC1 Control	173
CRC1IN	0xB9	0x2	CRC1 In	174
CRC1OUTH	0xBB	0x2	CRC1 Out High	175
CRC1OUTL	0xBA	0x2	CRC1 Out Low	175
CRC1POLH	0xBD	0x2	CRC1 Polynomial High	174
CRC1POLL	0xBC	0x2	CRC1 Polynomial Low	174
DC0CF	0xB2	0x2	DC0 Configuration	281
DC0CN	0xB1	0x2	DC0 Control	280
DC0MD	0xB3	0x2	DC0 Mode	282
DC0RDY	0xFD	0x2	DC0 Ready	283
DEVICEID	0xE9	0xF	Device ID	255
DMA0BUSY	0xD5	0x2	DMA0 Busy	154
DMA0EN	0xD2	0x2	DMA0 Enable	151
DMA0INT	0xD3	0x2	DMA0 Interrupt	152
DMA0MINT	0xD4	0x2	DMA0 Middle Interrupt	153
DMA0NAOH	0xCD	0x2	DMA0 Address Offset High (Selected Channel)	159
DMA0NAOL	0xCC	0x2	DMA0 Address Offset Low (Selected Channel)	159
DMA0NBAH	0xCB	0x2	DMA0 Base Address High (Selected Channel)	158
DMA0NBAL	0xCA	0x2	DMA0 Base Address Low (Selected Channel)	158
DMA0NCF	0xC9	0x2	DMA0 Configuration	157
DMA0NMD	0xD6	0x2	DMA0 Mode (Selected Channel)	156
DMA0NSZH	0xCF	0x2	DMA0 Size High (Selected Channel)	160
DMA0NSZL	0xCE	0x2	DMA0 Size Low (Selected Channel)	160
DMA0SEL	0xD1	0x2	DMA0 Channel Select	155
DPH	0x83	All Pages	Data Pointer High	121
DPL	0x82	All Pages	Data Pointer Low	121
EIE1	0xE6	All Pages	Extended Interrupt Enable 1	244
EIE2	0xE7	All Pages	Extended Interrupt Enable 2	246
EIP1	0xF6	All Pages	Extended Interrupt Priority 1	245
EIP2	0xF7	All Pages	Extended Interrupt Priority 2	247
EMIOCF	0xAB	0x0	EMIF Configuration	134
EMIOCN	0xAA	0x0	EMIF Control	133
EMIOTC	0xAF	0x0	EMIF Timing Control	139
ENC0CN	0xC5	0x2	ENC0 Control	215

Si102x/3x

Table 16.3. Special Function Registers (Continued)

SFRs are listed in alphabetical order. All undefined SFR locations are reserved.

Register	Address	SFR Page	Description	Page
ENC0H	0xC4	0x2	ENC0 High	216
ENC0L	0xC2	0x2	ENC0 Low	216
ENC0M	0xC3	0x2	ENC0 Middle	216
FLKEY	0xB7	All Pages	Flash Lock And Key	261
FLSCL	0xB6	0xF	Flash Scale Register	262
FLWR	0xE5	0x0	Flash Write Only	262
FRBCN	0xB5	0xF	Flash Read Buffer Control	263
IE	0xA8	All Pages	Interrupt Enable	242
IP	0xB8	All Pages	Interrupt Priority	243
IREF0CF	0xB9	0xF	Current Reference IREF0 Configuration	111
IREF0CN	0xB9	0x0	Current Reference IREF0 Configuration	110
IT01CF	0xE4	0x0 and 0xF	INT0/INT1 Configuration	249
LCD0BLINK	0x9E	0x2	LCD0 Blink Mask	353
LCD0BUFCF	0xAC	0xF	LCD0 Buffer Configuration	357
LCD0BUFCN	0x9C	0xF	LCD0 Buffer Control	356
LCD0BUFMD	0xB6	0x2	LCD0 Buffer Mode	357
LCD0CF	0xA5	0x2	LCD0 Configuration	355
LCD0CHPCF	0xAD	0x2	LCD0 Charge Pump Configuration	356
LCD0CHPCN	0xB5	0x2	LCD0 Charge Pump Control	355
LCD0CHPMD	0xAE	0x2	LCD0 Charge Pump Mode	356
LCD0CLKDIVH	0xAA	0x2	LCD0 Clock Divider High	352
LCD0CLKDIVL	0xA9	0x2	LCD0 Clock Divider Low	352
LCD0CN	0x9D	0x2	LCD0 Control	344
LCD0CNTRST	0x9C	0x2	LCD0 Contrast	348
LCD0D0	0x89	0x2	LCD0 Data 0	342
LCD0D1	0x8A	0x2	LCD0 Data 1	342
LCD0D2	0x8B	0x2	LCD0 Data 2	342
LCD0D3	0x8C	0x2	LCD0 Data 3	342
LCD0D4	0x8D	0x2	LCD0 Data 4	342
LCD0D5	0x8E	0x2	LCD0 Data 5	342
LCD0D6	0x91	0x2	LCD0 Data 6	342
LCD0D7	0x92	0x2	LCD0 Data 7	342
LCD0D8	0x93	0x2	LCD0 Data 8	342

Table 16.3. Special Function Registers (Continued)

SFRs are listed in alphabetical order. All undefined SFR locations are reserved.

Register	Address	SFR Page	Description	Page
LCD0D9	0x94	0x2	LCD0 Data 9	342
LCD0DA	0x95	0x2	LCD0 Data A	342
LCD0DB	0x96	0x2	LCD0 Data B	342
LCD0DC	0x97	0x2	LCD0 Data C	342
LCD0DD	0x99	0x2	LCD0 Data D	342
LCD0DE	0x9A	0x2	LCD0 Data E	342
LCD0DF	0x9B	0x2	LCD0 Data F	342
LCD0MSCF	0xAC	0x2	LCD0 Master Configuration	350
LCD0MSCN	0xAB	0x2	LCD0 Master Control	349
LCD0PWR	0xA4	0x2	LCD0 Power	350
LCD0TOGR	0x9F	0x2	LCD0 Toggle Rate	354
LCD0VBMCF	0xAF	0x2	LCD0 VBAT Monitor Configuration	357
LCD0VBMCN	0xA6	0x2	LCD0 VBAT Monitor Control	351
OSCICL	0xB3	0xF	Internal Oscillator Calibration	300
OSICN	0xB2	0x0	Internal Oscillator Control	299
OSCXCN	0xB1	0x0	External Oscillator Control	301
P0DRV	0xA4	0xF	Port 0 Drive Strength	373
P0MASK	0xC7	0x0	Port 0 Mask	368
P0MAT	0xD7	0x0	Port 0 Match	368
P0MDIN	0xF1	0x0	Port 0 Input Mode Configuration	372
P0MDOUT	0xA4	0x0	Port 0 Output Mode Configuration	372
P0SKIP	0xD4	0x0	Port 0 Skip	371
P0	0x80	All Pages	Port 0 Latch	371
P1DRV	0xA5	0xF	Port 1 Drive Strength	375
P1MASK	0xBF	0x0	Port 1 Mask	369
P1MAT	0xCF	0x0	Port 1 Match	369
P1MDIN	0xF2	0x0	Port 1 Input Mode Configuration	374
P1MDOUT	0xA5	0x0	Port 1 Output Mode Configuration	375
P1SKIP	0xD5	0x0	Port 1 Skip	374
P1	0x90	All Pages	Port 1 Latch	373
P2DRV	0xA6	0xF	Port 2 Drive Strength	378
P2MDIN	0xF3	0x0	Port 2 Input Mode Configuration	377
P2MDOUT	0xA6	0x0	Port 2 Output Mode Configuration	377
P2SKIP	0xD6	0x0	Port 2 Skip	376

Table 16.3. Special Function Registers (Continued)

SFRs are listed in alphabetical order. All undefined SFR locations are reserved.

Register	Address	SFR Page	Description	Page
P2	0xA0	All Pages	Port 2 Latch	376
P3DRV	0xA1	0xF	Port 3 Drive Strength	380
P3MDIN	0xF1	0xF	Port 3 Input Mode Configuration	379
P3MDOUT	0xB1	0xF	P3 Mode Out	379
P3	0xB0	All Pages	Port 3	378
P4DRV	0xA2	0xF	Port 4 Drive Strength	382
P4MDIN	0xF2	0xF	Port 4 Input Mode Configuration	381
P4MDOUT	0xF9	0xF	P4 Mode Out	381
P4	0xD9	0xF	Port 4 Latch	380
P5DRV	0xA3	0xF	Port 5 Drive Strength	384
P5MDIN	0xF3	0xF	Port 5 Input Mode Configuration	383
P5MDOUT	0xFA	0xF	P5 Mode Out	383
P5	0xDA	0xF	Port 5 Latch	382
P6DRV	0xAA	0xF	Port 6 Drive Strength	386
P6MDIN	0xF4	0xF	Port 6 Input Mode Configuration	385
P6MDOUT	0xFB	0xF	P6 Mode Out	385
P6	0xDB	0xF	Port 6 Latch	384
P7DRV	0xAB	0xF	Port 7 Drive Strength	387
P7MDOUT	0xFC	0xF	P7 Mode Out	387
P7	0xDC	0xF	Port 7 Latch	386
PC0CMP0H	0xE3	0x2	PC0 Comparator 0 High	336
PC0CMP0L	0xE1	0x2	PC0 Comparator 0 Low	336
PC0CMP0M	0xE2	0x2	PC0 Comparator 0 Middle	336
PC0CMP1H	0xF3	0x2	PC0 Comparator 1 High	337
PC0CMP1L	0xF1	0x2	PC0 Comparator 1 Low	337
PC0CMP1M	0xF2	0x2	PC0 Comparator 1 Middle	337
PC0CTR0H	0xDC	0x2	PC0 Counter 0 High	334
PC0CTR0L	0xDA	0x2	PC0 Counter 0 Low	334
PC0CTR0M	0xD8	0x2	PC0 Counter 0 Middle	334
PC0CTR1H	0xDF	0x2	PC0 Counter 1 High	335
PC0CTR1L	0xDD	0x2	PC0 Counter 1 Low	335
PC0DCH	0xFA	0x2	PC0 Debounce Configuration High	332
PC0DCL	0xF9	0x2	PC0 Debounce Configuration Low	333
PC0HIST	0xF4	0x2	PC0 History	338

Table 16.3. Special Function Registers (Continued)

SFRs are listed in alphabetical order. All undefined SFR locations are reserved.

Register	Address	SFR Page	Description	Page
PC0INT0	0xFB	0x2	PC0 Interrupt 0	339
PC0INT1	0xFC	0x2	PC0 Interrupt 1	340
PC0MD	0xD9	0x2	PC0 Mode	328
PC0PCF	0xD7	0x2	PC0 Pull-up Configuration	329
PC0STAT	0xC1	0x2	PC0 Status	331
PC0TH	0xE4	0x2	PC0 Threshold	330
PCA0CN	0xD8	All Pages	PCA0 Control	527
PCA0CPH0	0xFC	0x0	PCA0 Capture 0 High	532
PCA0CPH1	0xEA	0x0	PCA0 Capture 1 High	532
PCA0CPH2	0xEC	0x0	PCA0 Capture 2 High	532
PCA0CPH3	0xEE	0x0	PCA0 Capture 3 High	532
PCA0CPH4	0xFE	0x0	PCA0 Capture 4 High	532
PCA0CPH5	0xD3	0x0	PCA0 Capture 5 High	532
PCA0CPL0	0xFB	0x0	PCA0 Capture 0 Low	532
PCA0CPL1	0xE9	0x0	PCA0 Capture 1 Low	532
PCA0CPL2	0xEB	0x0	PCA0 Capture 2 Low	532
PCA0CPL3	0xED	0x0	PCA0 Capture 3 Low	532
PCA0CPL4	0xFD	0x0	PCA0 Capture 4 Low	532
PCA0CPL5	0xD2	0x0	PCA0 Capture 5 Low	532
PCA0CPM0	0xDA	0x0	PCA0 Module 0 Mode Register	530
PCA0CPM1	0xDB	0x0	PCA0 Module 1 Mode Register	530
PCA0CPM2	0xDC	0x0	PCA0 Module 2 Mode Register	530
PCA0CPM3	0xDD	0x0	PCA0 Module 3 Mode Register	530
PCA0CPM4	0xDE	0x0	PCA0 Module 4 Mode Register	530
PCA0CPM5	0xCE	0x0	PCA0 Module 5 Mode Register	530
PCA0H		0x0	PCA0 Counter High	531
PCA0L	0xF9	0x0	PCA0 Counter Low	531
PCA0MD	0xD9	0x0	PCA0 Mode	528
PCA0PWM	0xDF	0x0	PCA0 PWM Configuration	529
PCLKACT	0xF5	0xF	Peripheral Clock Enable Active Mode	267
PCLKEN	0xFE	0xF	Peripheral Clock Enables (LP Idle)	268
PCON	0x87	All Pages	Power Control	275
PMU0CF	0xB5	0x0	PMU0 Configuration 0	272
PMU0FL	0xB6	0x0	PMU0 flag	273

Si102x/3x

Table 16.3. Special Function Registers (Continued)

SFRs are listed in alphabetical order. All undefined SFR locations are reserved.

Register	Address	SFR Page	Description	Page
PMU0MD	0xB3	0x0	Internal Oscillator Calibration	274
PSBANK	0x84	All Pages	Flash Page Switch Bank SFR	127
PSCTL	0x8F	All Pages	Program Store R/W Control	260
PSW	0xD0	All Pages	Program Status Word	123
REF0CN	0xD1	0x0	Voltage Reference Control	102
REG0CN	0xC9	0x0	Voltage Regulator (REG0) Control	284
REVID	0xEA	0xF	Revision ID	256
RSTSRC	0xEF	0x0	Reset Source Configuration/Status	292
RTC0ADR	0xAC	0x0	RTC0 Address	305
RTC0DAT	0xAD	0x0	RTC0 Data	306
RTC0KEY	0xAE	0x0	RTC0 Key	305
SBUF0	0x99	0x0	UART0 Data Buffer	415
SCON0	0x98	All Pages	UART0 Control	414
SFRLAST	0x86	All Pages	SFR Page Stack Last	227
SFRNEXT	0x85	All Pages	SFR Page Stack Next	226
SFRPAGE	0xA7	All Pages	SFR Page	225
SFRPGCN	0x8E	0xF	SFR Page Control	224
SMB0ADM	0xF5	0x0	SMBus Slave Address Mask	399
SMB0ADR	0xF4	0x0	SMBus Slave Address	398
SMB0CF	0xC1	0x0	SMBus0 Configuration	394
SMB0CN	0xC0	All Pages	SMBus0 Control	396
SMB0DAT	0xC2	0x0	SMBus0 Data	400
SPI0CFG	0xA1	0x0	SPI0 Configuration	425
SPI0CKR	0xA2	0x0	SPI0 Clock Rate Control	427
SPI0CN	0xF8	0x0	SPI0 Control	426
SPI0DAT	0xA3	0x0	SPI0 Data	427
SPI1CFG	0xA1	0x2	SPI1 Configuration	438
SPI1CKR	0xA2	0x2	SPI1 Clock Rate Control	440
SPI1CN	0xF8	0x2	SPI1 Control	439
SPI1DAT	0xA3	0x2	SPI1 Data	440
SP	0x81	All Pages	Stack Pointer	122
TCON	0x88	All Pages	Timer/Counter Control	497
TH0	0x8C	0x0	Timer/Counter 0 High	500
TH1	0x8D	0x0	Timer/Counter 1 High	500

Table 16.3. Special Function Registers (Continued)

SFRs are listed in alphabetical order. All undefined SFR locations are reserved.

Register	Address	SFR Page	Description	Page
TL0	0x8A	0x0	Timer/Counter 0 Low	499
TL1	0x8B	0x0	Timer/Counter 1 Low	499
TMOD	0x89	0x0	Timer/Counter Mode	498
TMR2CN	0xC8	All Pages	Timer/Counter 2 Control	504
TMR2H	0xCD	0x0	Timer/Counter 2 High	506
TMR2L	0xCC	0x0	Timer/Counter 2 Low	506
TMR2RLH	0xCB	0x0	Timer/Counter 2 Reload High	505
TMR2RLL	0xCA	0x0	Timer/Counter 2 Reload Low	505
TMR3CN	0x91	0x0	Timer/Counter 3 Control	510
TMR3H	0x95	0x0	Timer/Counter 3 High	512
TMR3L	0x94	0x0	Timer/Counter 3 Low	512
TMR3RLH	0x93	0x0	Timer/Counter 3 Reload High	511
TMR3RLL	0x92	0x0	Timer/Counter 3 Reload Low	511
TOFFH	0xBB	0xF	Temperature Offset High	99
TOFFL	0xBD	0xF	Temperature Offset Low	99
VDM0CN	0xFF	All Pages	VDD Monitor Control	289
XBR0	0xE1	0x0 and 0xF	Port I/O Crossbar Control 0	365
XBR1	0xE2	0x0 and 0xF	Port I/O Crossbar Control 1	366
XBR2	0xE3	0x0 and 0xF	Port I/O Crossbar Control 2	367

17. Interrupt Handler

The Si102x/3x microcontroller family includes an extended interrupt system supporting multiple interrupt sources and two priority levels. The allocation of interrupt sources between on-chip peripherals and external input pins varies according to the specific version of the device. Refer to Table 17.1, “Interrupt Summary,” on page 240 for a detailed listing of all interrupt sources supported by the device. Refer to the data sheet section associated with a particular on-chip peripheral for information regarding valid interrupt conditions for the peripheral and the behavior of its interrupt-pending flag(s).

Each interrupt source has one or more associated interrupt-pending flag(s) located in an SFR or an indirect register. When a peripheral or external source meets a valid interrupt condition, the associated interrupt-pending flag is set to logic 1. If both global interrupts and the specific interrupt source is enabled, a CPU interrupt request is generated when the interrupt-pending flag is set.

As soon as execution of the current instruction is complete, the CPU generates an LCALL to a predetermined address to begin execution of an interrupt service routine (ISR). Each ISR must end with an RETI instruction, which returns program execution to the next instruction that would have been executed if the interrupt request had not occurred. If interrupts are not enabled, the interrupt-pending flag is ignored by the hardware and program execution continues as normal. (The interrupt-pending flag is set to logic 1 regardless of the interrupt's enable/disable state.)

Some interrupt-pending flags are automatically cleared by hardware when the CPU vectors to the ISR. However, most are not cleared by the hardware and must be cleared by software before returning from the ISR. If an interrupt-pending flag remains set after the CPU completes the return-from-interrupt (RETI) instruction, a new interrupt request will be generated immediately and the CPU will re-enter the ISR after the completion of the next instruction.

17.1. Enabling Interrupt Sources

Each interrupt source can be individually enabled or disabled through the use of an associated interrupt enable bit in the Interrupt Enable and Extended Interrupt Enable SFRs. However, interrupts must first be globally enabled by setting the EA bit (IE.7) to logic 1 before the individual interrupt enables are recognized. Setting the EA bit to logic 0 disables all interrupt sources regardless of the individual interrupt-enable settings. Note that interrupts which occur when the EA bit is set to logic 0 will be held in a pending state, and will not be serviced until the EA bit is set back to logic 1.

17.2. MCU Interrupt Sources and Vectors

The CPU services interrupts by generating an LCALL to a predetermined address (the interrupt vector address) to begin execution of an interrupt service routine (ISR). The interrupt vector addresses associated with each interrupt source are listed in Table 17.1 on page 240. Software should ensure that the interrupt vector for each enabled interrupt source contains a valid interrupt service routine.

Software can simulate an interrupt by setting any interrupt-pending flag to logic 1. If interrupts are enabled for the flag, an interrupt request will be generated and the CPU will vector to the ISR address associated with the interrupt-pending flag.

17.3. Interrupt Priorities

Each interrupt source can be individually programmed to one of two priority levels: low or high. A low priority interrupt service routine can be preempted by a high priority interrupt. A high priority interrupt cannot be preempted. If a high priority interrupt preempts a low priority interrupt, the low priority interrupt will finish execution after the high priority interrupt completes. Each interrupt has an associated interrupt priority bit in the Interrupt Priority and Extended Interrupt Priority registers used to configure its priority level. Low priority is the default.

If two interrupts are recognized simultaneously, the interrupt with the higher priority is serviced first. If both interrupts have the same priority level, a fixed priority order is used to arbitrate. See Table 17.1 on page 240 to determine the fixed priority order used to arbitrate between simultaneously recognized interrupts.

17.4. Interrupt Latency

Interrupt response time depends on the state of the CPU when the interrupt occurs. Pending interrupts are sampled and priority decoded each system clock cycle. Therefore, the fastest possible response time is 7 system clock cycles: 1 clock cycle to detect the interrupt, 1 clock cycle to execute a single instruction, and 5 clock cycles to complete the LCALL to the ISR. If an interrupt is pending when a RETI is executed, a single instruction is executed before an LCALL is made to service the pending interrupt. Therefore, the maximum response time for an interrupt (when no other interrupt is currently being serviced or the new interrupt is of greater priority) occurs when the CPU is performing an RETI instruction followed by a DIV as the next instruction. In this case, the response time is 19 system clock cycles: 1 clock cycle to detect the interrupt, 5 clock cycles to execute the RETI, 8 clock cycles to complete the DIV instruction and 5 clock cycles to execute the LCALL to the ISR. If the CPU is executing an ISR for an interrupt with equal or higher priority, the new interrupt will not be serviced until the current ISR completes, including the RETI and following instruction.

Table 17.1. Interrupt Summary

Interrupt Source	Interrupt Vector	Priority Order	Pending Flag	Bit addressable?	Cleared by HW?	Enable Flag	Priority Control
Reset	0x0000	Top	None	N/A	N/A	Always Enabled	Always Highest
External Interrupt 0 (INT0)	0x0003	0	IE0 (TCON.1)	Y	Y	EX0 (IE.0)	PX0 (IP.0)
Timer 0 Overflow	0x000B	1	TF0 (TCON.5)	Y	Y	ET0 (IE.1)	PT0 (IP.1)
External Interrupt 1 (INT1)	0x0013	2	IE1 (TCON.3)	Y	Y	EX1 (IE.2)	PX1 (IP.2)
Timer 1 Overflow	0x001B	3	TF1 (TCON.7)	Y	Y	ET1 (IE.3)	PT1 (IP.3)
UART0	0x0023	4	RI0 (SCON0.0) TI0 (SCON0.1)	Y	N	ES0 (IE.4)	PS0 (IP.4)
Timer 2 Overflow	0x002B	5	TF2H (TMR2CN.7) TF2L (TMR2CN.6)	Y	N	ET2 (IE.5)	PT2 (IP.5)
SPI0	0x0033	6	SPIF (SPI0CN.7) WCOL (SPI0CN.6) MODF (SPI0CN.5) RXOVRN (SPI0CN.4)	Y	N	ESPI0 (IE.6)	PSPI0 (IP.6)
SMB0	0x003B	7	SI (SMB0CN.0)	Y	N	ESMB0 (EIE1.0)	PSMB0 (EIP1.0)
SmaRTClock Alarm	0x0043	8	ALRM (RTC0CN.2)*	N	N	EARTC0 (EIE1.1)	PARTC0 (EIP1.1)
ADC0 Window Comparator	0x004B	9	AD0WINT (ADC0CN.3)	Y	N	EWADC0 (EIE1.2)	PWADC0 (EIP1.2)
ADC0 End of Conversion	0x0053	10	AD0INT (ADC0STA.5)	Y	N	EADC0 (EIE1.3)	PADC0 (EIP1.3)
Programmable Counter Array	0x005B	11	CF (PCA0CN.7) CCFn (PCA0CN.n)	Y	N	EPCA0 (EIE1.4)	PPCA0 (EIP1.4)
Comparator0	0x0063	12	CP0FIF (CPT0CN.4) CP0RIF (CPT0CN.5)	N	N	ECP0 (EIE1.5)	PCP0 (EIP1.5)
Comparator1	0x006B	13	CP1FIF (CPT1CN.4) CP1RIF (CPT1CN.5)	N	N	ECP1 (EIE1.6)	PCP1 (EIP1.6)
Timer 3 Overflow	0x0073	14	TF3H (TMR3CN.7) TF3L (TMR3CN.6)	N	N	ET3 (EIE1.7)	PT3 (EIP1.7)
VDD/VBAT Supply Monitor Early Warning	0x007B	15	VDDOK (VDM0CN.5) ¹ VBOK (VDM0CN.2) ¹			EWARN (EIE2.0)	PWARN (EIP2.0)
Port Match	0x0083	16	None			EMAT (EIE2.1)	PMAT (EIP2.1)

Table 17.1. Interrupt Summary

Interrupt Source	Interrupt Vector	Priority Order	Pending Flag	Bit addressable?	Cleared by HW?	Enable Flag	Priority Control
SmaRTClock Oscillator Fail	0x008B	17	OSCFail (RTC0CN.5) ²	N	N	ERTC0F (EIE2.2)	PFRTC0F (EIP2.2)
SPI1	0x0093	18	SPIF (SPI1CN.7) WCOL (SPI1CN.6) MODF (SPI1CN.5) RXOVRN (SPI1CN.4)	N	N	ESPI1 (EIE2.3)	PSP11 (EIP2.3)
Pulse Counter	0x009B	19	C0ZF (PC0CN.4) C1ZF (PC0CN.6)	N	N	EPC0 (EIE2.4)	PPC0 (EIP2.4)
DMA0	0x00A3	20	DMAINT0...7 DMAMINT0...7	N	N	EDMA0 (EIE2.5)	PDMA0 (EIP2.5)
Encoder0	0x00AB	21	ENCERR(ENCCN.6)	N	N	EENC0 (EIE2.6)	PENC0 (EIP2.6)
AES	0x00B3	22	AESDONE (AESBCF.5)	N	N	EAES0 (EIE2.7)	PAES0 (EIP2.7)
Notes:							
1. Indicates a read-only interrupt pending flag. The interrupt enable may be used to prevent software from vectoring to the associated interrupt service routine.							
2. Indicates a register located in an indirect memory space.							

17.5. Interrupt Register Descriptions

The SFRs used to enable the interrupt sources and set their priority level are described in the following register descriptions. Refer to the data sheet section associated with a particular on-chip peripheral for information regarding valid interrupt conditions for the peripheral and the behavior of its interrupt-pending flag(s).

Si102x/3x

SFR Definition 17.1. IE: Interrupt Enable

Bit	7	6	5	4	3	2	1	0
Name	EA	ESPI0	ET2	ES0	ET1	EX1	ET0	EX0
Type	R/W	R/W	R/W	R/W	R/W	R/W	R/W	R/W
Reset	0	0	0	0	0	0	0	0

SFR Page = All Pages; SFR Address = 0xA8; Bit-Addressable

Bit	Name	Function
7	EA	<p>Enable All Interrupts. Globally enables/disables all interrupts. It overrides individual interrupt mask settings. 0: Disable all interrupt sources. 1: Enable each interrupt according to its individual mask setting.</p>
6	ESPI0	<p>Enable Serial Peripheral Interface (SPI0) Interrupt. This bit sets the masking of the SPI0 interrupts. 0: Disable all SPI0 interrupts. 1: Enable interrupt requests generated by SPI0.</p>
5	ET2	<p>Enable Timer 2 Interrupt. This bit sets the masking of the Timer 2 interrupt. 0: Disable Timer 2 interrupt. 1: Enable interrupt requests generated by the TF2L or TF2H flags.</p>
4	ES0	<p>Enable UART0 Interrupt. This bit sets the masking of the UART0 interrupt. 0: Disable UART0 interrupt. 1: Enable UART0 interrupt.</p>
3	ET1	<p>Enable Timer 1 Interrupt. This bit sets the masking of the Timer 1 interrupt. 0: Disable all Timer 1 interrupt. 1: Enable interrupt requests generated by the TF1 flag.</p>
2	EX1	<p>Enable External Interrupt 1. This bit sets the masking of External Interrupt 1. 0: Disable external interrupt 1. 1: Enable interrupt requests generated by the $\overline{\text{INT1}}$ input.</p>
1	ET0	<p>Enable Timer 0 Interrupt. This bit sets the masking of the Timer 0 interrupt. 0: Disable all Timer 0 interrupt. 1: Enable interrupt requests generated by the TF0 flag.</p>
0	EX0	<p>Enable External Interrupt 0. This bit sets the masking of External Interrupt 0. 0: Disable external interrupt 0. 1: Enable interrupt requests generated by the $\overline{\text{INT0}}$ input.</p>

SFR Definition 17.2. IP: Interrupt Priority

Bit	7	6	5	4	3	2	1	0
Name		PSPI0	PT2	PS0	PT1	PX1	PT0	PX0
Type	R	R/W	R/W	R/W	R/W	R/W	R/W	R/W
Reset	1	0	0	0	0	0	0	0

SFR Page = All Pages; SFR Address = 0xB8; Bit-Addressable

Bit	Name	Function
7	Unused	Read = 1b, Write = don't care.
6	PSPI0	Serial Peripheral Interface (SPI0) Interrupt Priority Control. This bit sets the priority of the SPI0 interrupt. 0: SPI0 interrupt set to low priority level. 1: SPI0 interrupt set to high priority level.
5	PT2	Timer 2 Interrupt Priority Control. This bit sets the priority of the Timer 2 interrupt. 0: Timer 2 interrupt set to low priority level. 1: Timer 2 interrupt set to high priority level.
4	PS0	UART0 Interrupt Priority Control. This bit sets the priority of the UART0 interrupt. 0: UART0 interrupt set to low priority level. 1: UART0 interrupt set to high priority level.
3	PT1	Timer 1 Interrupt Priority Control. This bit sets the priority of the Timer 1 interrupt. 0: Timer 1 interrupt set to low priority level. 1: Timer 1 interrupt set to high priority level.
2	PX1	External Interrupt 1 Priority Control. This bit sets the priority of the External Interrupt 1 interrupt. 0: External Interrupt 1 set to low priority level. 1: External Interrupt 1 set to high priority level.
1	PT0	Timer 0 Interrupt Priority Control. This bit sets the priority of the Timer 0 interrupt. 0: Timer 0 interrupt set to low priority level. 1: Timer 0 interrupt set to high priority level.
0	PX0	External Interrupt 0 Priority Control. This bit sets the priority of the External Interrupt 0 interrupt. 0: External Interrupt 0 set to low priority level. 1: External Interrupt 0 set to high priority level.

SFR Definition 17.3. EIE1: Extended Interrupt Enable 1

Bit	7	6	5	4	3	2	1	0
Name	ET3	ECP1	ECP0	EPCA0	EADC0	EWADC0	ERTC0A	ESMB0
Type	R/W	R/W	R/W	R/W	R/W	R/W	R/W	R/W
Reset	0	0	0	0	0	0	0	0

SFR Page = All Pages; SFR Address = 0xE6

Bit	Name	Function
7	ET3	Enable Timer 3 Interrupt. This bit sets the masking of the Timer 3 interrupt. 0: Disable Timer 3 interrupts. 1: Enable interrupt requests generated by the TF3L or TF3H flags.
6	ECP1	Enable Comparator1 (CP1) Interrupt. This bit sets the masking of the CP1 interrupt. 0: Disable CP1 interrupts. 1: Enable interrupt requests generated by the CP1RIF or CP1FIF flags.
5	ECP0	Enable Comparator0 (CP0) Interrupt. This bit sets the masking of the CP0 interrupt. 0: Disable CP0 interrupts. 1: Enable interrupt requests generated by the CP0RIF or CP0FIF flags.
4	EPCA0	Enable Programmable Counter Array (PCA0) Interrupt. This bit sets the masking of the PCA0 interrupts. 0: Disable all PCA0 interrupts. 1: Enable interrupt requests generated by PCA0.
3	EADC0	Enable ADC0 Conversion Complete Interrupt. This bit sets the masking of the ADC0 Conversion Complete interrupt. 0: Disable ADC0 Conversion Complete interrupt. 1: Enable interrupt requests generated by the AD0INT flag.
2	EWADC0	Enable Window Comparison ADC0 Interrupt. This bit sets the masking of ADC0 Window Comparison interrupt. 0: Disable ADC0 Window Comparison interrupt. 1: Enable interrupt requests generated by ADC0 Window Compare flag (AD0WINT).
1	ERTC0A	Enable SmarTclock Alarm Interrupts. This bit sets the masking of the SmarTclock Alarm interrupt. 0: Disable SmarTclock Alarm interrupts. 1: Enable interrupt requests generated by a SmarTclock Alarm.
0	ESMB0	Enable SMBus (SMB0) Interrupt. This bit sets the masking of the SMB0 interrupt. 0: Disable all SMB0 interrupts. 1: Enable interrupt requests generated by SMB0.

SFR Definition 17.4. EIP1: Extended Interrupt Priority 1

Bit	7	6	5	4	3	2	1	0
Name	PT3	PCP1	PCP0	PPCA0	PADC0	PWADC0	PRTC0A	PSMB0
Type	R/W	R/W	R/W	R/W	R/W	R/W	R/W	R/W
Reset	0	0	0	0	0	0	0	0

SFR Page = All Pages; SFR Address = 0xF6

Bit	Name	Function
7	PT3	Timer 3 Interrupt Priority Control. This bit sets the priority of the Timer 3 interrupt. 0: Timer 3 interrupts set to low priority level. 1: Timer 3 interrupts set to high priority level.
6	PCP1	Comparator1 (CP1) Interrupt Priority Control. This bit sets the priority of the CP1 interrupt. 0: CP1 interrupt set to low priority level. 1: CP1 interrupt set to high priority level.
5	PCP0	Comparator0 (CP0) Interrupt Priority Control. This bit sets the priority of the CP0 interrupt. 0: CP0 interrupt set to low priority level. 1: CP0 interrupt set to high priority level.
4	PPCA0	Programmable Counter Array (PCA0) Interrupt Priority Control. This bit sets the priority of the PCA0 interrupt. 0: PCA0 interrupt set to low priority level. 1: PCA0 interrupt set to high priority level.
3	PADC0	ADC0 Conversion Complete Interrupt Priority Control. This bit sets the priority of the ADC0 Conversion Complete interrupt. 0: ADC0 Conversion Complete interrupt set to low priority level. 1: ADC0 Conversion Complete interrupt set to high priority level.
2	PWADC0	ADC0 Window Comparator Interrupt Priority Control. This bit sets the priority of the ADC0 Window interrupt. 0: ADC0 Window interrupt set to low priority level. 1: ADC0 Window interrupt set to high priority level.
1	PRTC0A	SmaRTClock Alarm Interrupt Priority Control. This bit sets the priority of the SmaRTClock Alarm interrupt. 0: SmaRTClock Alarm interrupt set to low priority level. 1: SmaRTClock Alarm interrupt set to high priority level.
0	PSMB0	SMBus (SMB0) Interrupt Priority Control. This bit sets the priority of the SMB0 interrupt. 0: SMB0 interrupt set to low priority level. 1: SMB0 interrupt set to high priority level.

SFR Definition 17.5. EIE2: Extended Interrupt Enable 2

Bit	7	6	5	4	3	2	1	0
Name	EAES0	EENC0	EDMA0	EPC0	ESPI1	ERTC0F	EMAT	EWARN
Type	R/W	R/W	R/W	R/W	R/W	R/W	R/W	R/W
Reset	0	0	0	0	0	0	0	0

SFR Page = All Pages; SFR Address = 0xE7

Bit	Name	Function
7	EAES0	<p>Enable AES0 Interrupt.</p> <p>This bit sets the masking of AES0 interrupts.</p> <p>0: Disable all AES0 interrupts.</p> <p>1: Enable interrupt requests generated by AES0.</p>
6	EENC0	<p>Enable Encoder (ENC0) Interrupt.</p> <p>This bit sets the masking of ENC0 interrupts.</p> <p>0: Disable all ENC0 interrupts.</p> <p>1: Enable interrupt requests generated by ENC0.</p>
5	EDMA0	<p>Enable DMA0 Interrupt.</p> <p>This bit sets the masking of DMA0 interrupts.</p> <p>0: Disable all DMA0 interrupts.</p> <p>1: Enable interrupt requests generated by DMA0.</p>
4	EPC0	<p>Enable Pulse Counter (PC0) Interrupt.</p> <p>This bit sets the masking of PC0 interrupts.</p> <p>0: Disable all PC0 interrupts.</p> <p>1: Enable interrupt requests generated by PC0.</p>
3	ESPI1	<p>Enable Serial Peripheral Interface (SPI1) Interrupt.</p> <p>This bit sets the masking of the SPI1 interrupts.</p> <p>0: Disable all SPI1 interrupts.</p> <p>1: Enable interrupt requests generated by SPI1.</p>
2	ERTC0F	<p>Enable SmarTclock Oscillator Fail Interrupt.</p> <p>This bit sets the masking of the SmarTclock Alarm interrupt.</p> <p>0: Disable SmarTclock Alarm interrupts.</p> <p>1: Enable interrupt requests generated by SmarTclock Alarm.</p>
1	EMAT	<p>Enable Port Match Interrupts.</p> <p>This bit sets the masking of the Port Match Event interrupt.</p> <p>0: Disable all Port Match interrupts.</p> <p>1: Enable interrupt requests generated by a Port Match.</p>
0	EWARN	<p>Enable VDD/DC+ Supply Monitor Early Warning Interrupt.</p> <p>This bit sets the masking of the VDD/DC+ Supply Monitor Early Warning interrupt.</p> <p>0: Disable the VDD/DC+ Supply Monitor Early Warning interrupt.</p> <p>1: Enable interrupt requests generated by VDD/DC+ Supply Monitor.</p>

SFR Definition 17.6. EIP2: Extended Interrupt Priority 2

Bit	7	6	5	4	3	2	1	0
Name	PAES0	PENC0	PDMA0	PPC0	PSPI1	PRTC0F	PMAT	PWARN
Type	R	R	R	R	R/W	R/W	R/W	R/W
Reset	0	0	0	0	0	0	0	0

SFR Page = All Pages; SFR Address = 0xF7

Bit	Name	Function
7	PAES0	AES0 Interrupt Priority Control. This bit sets the priority of the AES0 interrupt. 0: AES0 interrupt set to low priority level. 1: AES0 interrupt set to high priority level.
6	PENC0	Encoder (ENC0) Interrupt Priority Control. This bit sets the priority of the ENC0 interrupt. 0: ENC0 interrupt set to low priority level. 1: SPI0 interrupt set to high priority level.
5	PDMA0	DMA0 Interrupt Priority Control. This bit sets the priority of the DMA0 interrupt. 0: DMA0 interrupt set to low priority level. 1: DMA0 interrupt set to high priority level.
4	PPC0	Pulse Counter (PC0) Interrupt Priority Control. This bit sets the priority of the PC0 interrupt. 0: PC0 interrupt set to low priority level. 1: PC0 interrupt set to high priority level.
3	PSPI0	Serial Peripheral Interface (SPI1) Interrupt Priority Control. This bit sets the priority of the SPI0 interrupt. 0: SPI1 interrupt set to low priority level. 1: SPI1 interrupt set to high priority level.
2	PRTC0F	SmaRTClock Oscillator Fail Interrupt Priority Control. This bit sets the priority of the SmaRTClock Alarm interrupt. 0: SmaRTClock Alarm interrupt set to low priority level. 1: SmaRTClock Alarm interrupt set to high priority level.
1	PMAT	Port Match Interrupt Priority Control. This bit sets the priority of the Port Match Event interrupt. 0: Port Match interrupt set to low priority level. 1: Port Match interrupt set to high priority level.
0	PWARN	VDD/DC+ Supply Monitor Early Warning Interrupt Priority Control. This bit sets the priority of the VDD/DC+ Supply Monitor Early Warning interrupt. 0: VDD/DC+ Supply Monitor Early Warning interrupt set to low priority level. 1: VDD/DC+ Supply Monitor Early Warning interrupt set to high priority level.

17.6. External Interrupts $\overline{\text{INT0}}$ and $\overline{\text{INT1}}$

The $\overline{\text{INT0}}$ and $\overline{\text{INT1}}$ external interrupt sources are configurable as active high or low, edge or level sensitive. The IN0PL ($\overline{\text{INT0}}$ Polarity) and IN1PL ($\overline{\text{INT1}}$ Polarity) bits in the IT01CF register select active high or active low; the IT0 and IT1 bits in TCON (Section “33.1. Timer 0 and Timer 1” on page 493) select level or edge sensitive. The table below lists the possible configurations.

IT0	IN0PL	$\overline{\text{INT0}}$ Interrupt
1	0	Active low, edge sensitive
1	1	Active high, edge sensitive
0	0	Active low, level sensitive
0	1	Active high, level sensitive

IT1	IN1PL	$\overline{\text{INT1}}$ Interrupt
1	0	Active low, edge sensitive
1	1	Active high, edge sensitive
0	0	Active low, level sensitive
0	1	Active high, level sensitive

$\overline{\text{INT0}}$ and $\overline{\text{INT1}}$ are assigned to Port pins as defined in the IT01CF register (see SFR Definition 17.7). Note that $\overline{\text{INT0}}$ and $\overline{\text{INT1}}$ Port pin assignments are independent of any Crossbar assignments. $\overline{\text{INT0}}$ and $\overline{\text{INT1}}$ will monitor their assigned Port pins without disturbing the peripheral that was assigned the Port pin via the Crossbar. To assign a Port pin only to $\overline{\text{INT0}}$ and/or $\overline{\text{INT1}}$, configure the Crossbar to skip the selected pin(s). This is accomplished by setting the associated bit in register XBR0 (see Section “27.3. Priority Crossbar Decoder” on page 362 for complete details on configuring the Crossbar).

IE0 (TCON.1) and IE1 (TCON.3) serve as the interrupt-pending flags for the $\overline{\text{INT0}}$ and $\overline{\text{INT1}}$ external interrupts, respectively. If an $\overline{\text{INT0}}$ or $\overline{\text{INT1}}$ external interrupt is configured as edge-sensitive, the corresponding interrupt-pending flag is automatically cleared by the hardware when the CPU vectors to the ISR. When configured as level sensitive, the interrupt-pending flag remains logic 1 while the input is active as defined by the corresponding polarity bit (IN0PL or IN1PL); the flag remains logic 0 while the input is inactive. The external interrupt source must hold the input active until the interrupt request is recognized. It must then deactivate the interrupt request before execution of the ISR completes or another interrupt request will be generated.

SFR Definition 17.7. IT01CF: INT0/INT1 Configuration

Bit	7	6	5	4	3	2	1	0
Name	IN1PL	IN1SL[2:0]			IN0PL	IN0SL[2:0]		
Type	R/W	R/W			R/W	R/W		
Reset	0	0	0	0	0	0	0	1

SFR Page = 0x0 and 0xF; SFR Address = 0xE4

Bit	Name	Function
7	IN1PL	INT1 Polarity. 0: $\overline{\text{INT1}}$ input is active low. 1: $\overline{\text{INT1}}$ input is active high.
6:4	IN1SL[2:0]	INT1 Port Pin Selection Bits. These bits select which Port pin is assigned to $\overline{\text{INT1}}$. Note that this pin assignment is independent of the Crossbar; $\overline{\text{INT1}}$ will monitor the assigned Port pin without disturbing the peripheral that has been assigned the Port pin via the Crossbar. The Crossbar will not assign the Port pin to a peripheral if it is configured to skip the selected pin. 000: Select P0.0 001: Select P0.1 010: Select P0.2 011: Select P0.3 100: Select P0.4 101: Select P0.5 110: Select P1.6 111: Select P1.7
3	IN0PL	INT0 Polarity. 0: $\overline{\text{INT0}}$ input is active low. 1: $\overline{\text{INT0}}$ input is active high.
2:0	IN0SL[2:0]	INT0 Port Pin Selection Bits. These bits select which Port pin is assigned to $\overline{\text{INT0}}$. Note that this pin assignment is independent of the Crossbar; $\overline{\text{INT0}}$ will monitor the assigned Port pin without disturbing the peripheral that has been assigned the Port pin via the Crossbar. The Crossbar will not assign the Port pin to a peripheral if it is configured to skip the selected pin. 000: Select P0.0 001: Select P0.1 010: Select P0.2 011: Select P0.3 100: Select P0.4 101: Select P0.5 110: Select P1.6 111: Select P1.7

18. Flash Memory

On-chip, re-programmable flash memory is included for program code and non-volatile data storage. The flash memory can be programmed in-system, a single byte at a time, through the C2 interface or by software using the MOVX write instruction. Once cleared to logic 0, a flash bit must be erased to set it back to logic 1. Flash bytes would typically be erased (set to 0xFF) before being reprogrammed. The write and erase operations are automatically timed by hardware for proper execution; data polling to determine the end of the write/erase operations is not required. Code execution is stalled during flash write/erase operations. Refer to Table 4.8 for complete flash memory electrical characteristics.

18.1. Programming the Flash Memory

The simplest means of programming the flash memory is through the C2 interface using programming tools provided by Silicon Laboratories or a third party vendor. This is the only means for programming a non-initialized device. For details on the C2 commands to program flash memory, see Section “35. C2 Interface” on page 533.

The flash memory can be programmed by software using the MOVX write instruction with the address and data byte to be programmed provided as normal operands. Before programming flash memory using MOVX, flash programming operations must be enabled by: (1) setting the PSWE Program Store Write Enable bit (PSCTL.0) to logic 1 (this directs the MOVX writes to target flash memory); and (2) Writing the flash key codes in sequence to the Flash Lock register (FLKEY). The PSWE bit remains set until cleared by software. For detailed guidelines on programming flash from firmware, please see Section “18.5. Flash Write and Erase Guidelines” on page 256.

To ensure the integrity of the flash contents, the on-chip VDD Monitor must be enabled and enabled as a reset source in any system that includes code that writes and/or erases flash memory from software. Furthermore, there should be no delay between enabling the V_{DD} Monitor and enabling the V_{DD} Monitor as a reset source. Any attempt to write or erase flash memory while the V_{DD} Monitor is disabled, or not enabled as a reset source, will cause a Flash Error device reset.

18.1.1. Flash Lock and Key Functions

Flash writes and erases by user software are protected with a lock and key function. The Flash Lock and Key Register (FLKEY) must be written with the correct key codes, in sequence, before flash operations may be performed. The key codes are: 0xA5, 0xF1. The timing does not matter, but the codes must be written in order. If the key codes are written out of order, or the wrong codes are written, flash writes and erases will be disabled until the next system reset. Flash writes and erases will also be disabled if a flash write or erase is attempted before the key codes have been written properly. The flash lock resets after each write or erase; the key codes must be written again before a following flash operation can be performed. The FLKEY register is detailed in SFR Definition 18.4.

18.1.2. Flash Erase Procedure

The flash memory is organized in 1024-byte pages. The erase operation applies to an entire page (setting all bytes in the page to 0xFF). To erase an entire 1024-byte page, perform the following steps:

1. Save current interrupt state and disable interrupts.
2. Set the PSEE bit (register PSCTL).
3. Set the PSWE bit (register PSCTL).
4. If writing to an address in Banks 1, 2, or 3, set the COBANK[1:0] bits (register PSBANK) for the appropriate bank.
5. Write the first key code to FLKEY: 0xA5.
6. Write the second key code to FLKEY: 0xF1.
7. Using the MOVX instruction, write a data byte to any location within the 1024-byte page to be erased.
8. Clear the PSWE and PSEE bits.

9. Restore previous interrupt state.

Steps 4–7 must be repeated for each 1024-byte page to be erased.

Notes:

1. Flash security settings may prevent erasure of some flash pages, such as the reserved area and the page containing the lock bytes. For a summary of flash security settings and restrictions affecting flash erase operations, please see Section “18.3. Security Options” on page 253.
2. 8-bit MOVX instructions cannot be used to erase or write to flash memory at addresses higher than 0x00FF.

18.1.3. Flash Write Procedure

A write to flash memory can clear bits to logic 0 but cannot set them; only an erase operation can set bits to logic 1 in flash. **A byte location to be programmed should be erased before a new value is written.**

The recommended procedure for writing a single byte in flash is as follows:

1. Save current interrupt state and disable interrupts.
2. Set the PSWE bit (register PSCTL).
3. Clear the PSEE bit (register PSCTL).
4. If writing to an address in Banks 1, 2, or 3, set the COBANK[1:0] bits (register PSBANK) for the appropriate bank.
5. Ensure that the flash byte has been erased (has a value of 0xFF).
6. Write the first key code to FLKEY: 0xA5.
7. Write the second key code to FLKEY: 0xF1.
8. Using the MOVX instruction, write a single data byte to the desired location within the 1024-byte sector.
9. Clear the PSWE bit.
10. Restore previous interrupt state.

Steps 2–8 must be repeated for each byte to be written.

Notes:

1. Flash security settings may prevent writes to some areas of flash, such as the reserved area. For a summary of flash security settings and restrictions affecting flash write operations, please see Section “18.3. Security Options” on page 253.
2. 8-bit MOVX instructions cannot be used to erase or write to flash memory at addresses higher than 0x00FF.

18.1.4. Flash Write Optimization

The flash write procedure includes a block write option to optimize the time to perform consecutive byte writes. When block write is enabled by setting the CHBLKW bit (FLRBCN.0), writes to flash will occur in blocks of 4 bytes and require the same amount of time as a single byte write. This is performed by caching the bytes whose address end in 00b, 01b, and 10b that is written to flash and then committing all four bytes to flash when the byte with address 11b is written. When block writes are enabled, if the write to the byte with address 11b does not occur, the other three data bytes written is not committed to flash.

A write to flash memory can clear bits to logic 0 but cannot set them; only an erase operation can set bits to logic 1 in flash. **The Flash Block to be programmed should be erased before a new value is written.**

The recommended procedure for writing a 4-byte flash block is as follows:

1. Save current interrupt state and disable interrupts.
2. Set the CHBLKW bit (register FLRBCN).
3. Set the PSWE bit (register PSCTL).
4. Clear the PSEE bit (register PSCTL).
5. If writing to an address in Banks 1, 2, or 3, set the COBANK[1:0] bits (register PSBANK) for the appropriate bank
6. Write the first key code to FLKEY: 0xA5.
7. Write the second key code to FLKEY: 0xF1.
8. Using the MOVX instruction, write the first data byte to the desired location within the 1024-byte sector whose address ends in 00b.
9. Write the first key code to FLKEY: 0xA5.
10. Write the second key code to FLKEY: 0xF1.
11. Using the MOVX instruction, write the second data byte to the next higher flash address ending in 01b.
12. Write the first key code to FLKEY: 0xA5.
13. Write the second key code to FLKEY: 0xF1.
14. Using the MOVX instruction, write the third data byte to the next higher flash address ending in 10b.
15. Write the first key code to FLKEY: 0xA5.
16. Write the second key code to FLKEY: 0xF1.
17. Using the MOVX instruction, write the final data byte to the next higher flash address ending in 11b.
18. Clear the PSWE bit.
19. Clear the CHBLKW bit.
20. Restore previous interrupt state.

Steps 5–17 must be repeated for each flash block to be written.

Notes:

1. Flash security settings may prevent writes to some areas of flash, such as the reserved area. For a summary of flash security settings and restrictions affecting flash write operations, please see Section “18.3. Security Options” on page 253.
2. 8-bit MOVX instructions cannot be used to erase or write to flash memory at addresses higher than 0x00FF.

18.2. Non-volatile Data Storage

The flash memory can be used for non-volatile data storage as well as program code. This allows data such as calibration coefficients to be calculated and stored at run time. Data is written using the MOVX write instruction and read using the MOVC instruction. Note: MOVX read instructions always target XRAM.

18.3. Security Options

The CIP-51 provides security options to protect the flash memory from inadvertent modification by software as well as to prevent the viewing of proprietary program code and constants. The Program Store Write Enable (bit PSWE in register PSCTL) and the Program Store Erase Enable (bit PSEE in register PSCTL) bits protect the flash memory from accidental modification by software. PSWE must be explicitly set to 1 before software can modify the flash memory; both PSWE and PSEE must be set to 1 before software can erase flash memory. Additional security features prevent proprietary program code and data constants from being read or altered across the C2 interface.

A Security Lock Byte located at the last byte of flash user space offers protection of the flash program memory from access (reads, writes, or erases) by unprotected code or the C2 interface. The flash security mechanism allows the user to lock n 1024-byte flash pages, starting at page 0 (addresses 0x0000 to 0x03FF), where n is the 1s complement number represented by the Security Lock Byte. **The page containing the Flash Security Lock Byte is unlocked when no other flash pages are locked (all bits of the Lock Byte are 1) and locked when any other flash pages are locked (any bit of the Lock Byte is 0).** See example in Figure 18.1

Security Lock Byte:	11111101b
ones Complement:	00000010b
Flash pages locked:	3 (First two flash pages + Lock Byte Page)

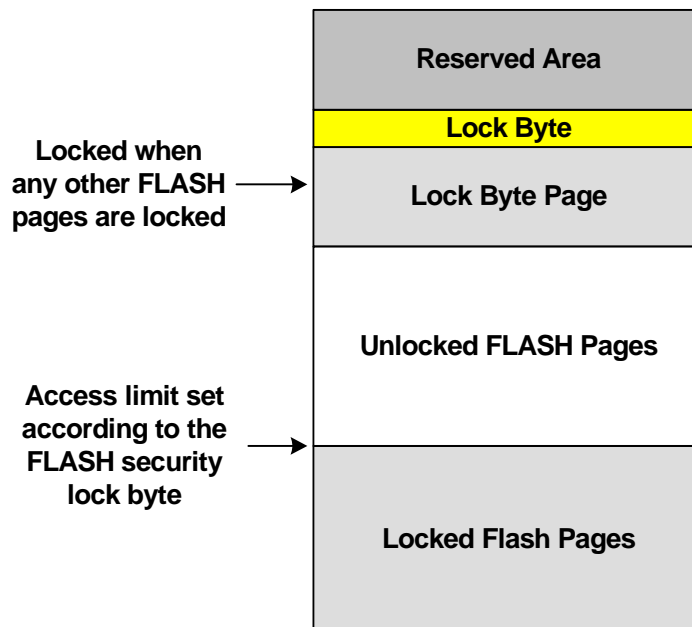

Figure 18.1. Flash Security Example

Si102x/3x

The level of flash security depends on the flash access method. The three flash access methods that can be restricted are reads, writes, and erases from the C2 debug interface, user firmware executing on unlocked pages, and user firmware executing on locked pages. Table 18.1 summarizes the flash security features of the Si102x/3x devices.

Table 18.1. Flash Security Summary

Action	C2 Debug Interface	User Firmware executing from:	
		an unlocked page	a locked page
Read, Write or Erase unlocked pages (except page with Lock Byte)	Permitted	Permitted	Permitted
Read, Write or Erase locked pages (except page with Lock Byte)	Not Permitted	Flash Error Reset	Permitted
Read or Write page containing Lock Byte (if no pages are locked)	Permitted	Permitted	Permitted
Read or Write page containing Lock Byte (if any page is locked)	Not Permitted	Flash Error Reset	Permitted
Read contents of Lock Byte (if no pages are locked)	Permitted	Permitted	Permitted
Read contents of Lock Byte (if any page is locked)	Not Permitted	Flash Error Reset	Permitted
Erase page containing Lock Byte (if no pages are locked)	Permitted	Flash Error Reset	Flash Error Reset
Erase page containing Lock Byte—Unlock all pages (if any page is locked)	C2 Device Erase Only	Flash Error Reset	Flash Error Reset
Lock additional pages (change 1s to 0s in the Lock Byte)	Not Permitted	Flash Error Reset	Flash Error Reset
Unlock individual pages (change 0s to 1s in the Lock Byte)	Not Permitted	Flash Error Reset	Flash Error Reset
Read, Write or Erase Reserved Area	Not Permitted	Flash Error Reset	Flash Error Reset

C2 Device Erase—Erases all flash pages including the page containing the Lock Byte.

Flash Error Reset—Not permitted; Causes Flash Error Device Reset (FERROR bit in RSTSRC is '1' after reset).

- All prohibited operations that are performed via the C2 interface are ignored (do not cause device reset).
- Locking any flash page also locks the page containing the Lock Byte.
- Once written to, the Lock Byte cannot be modified except by performing a C2 Device Erase.
- If user code writes to the Lock Byte, the Lock does not take effect until the next device reset.

18.4. Determining the Device Part Number at Run Time

In many applications, user software may need to determine the MCU part number at run time in order to determine the hardware capabilities. The part number can be determined by reading the value of the DEVICEID Special Function Register.

The value of the DEVICEID register can be decoded as follows:

0xE0—Si1020
 0xE1—Si1021
 0xE2—Si1022
 0xE3—Si1023
 0xE4—Si1024
 0xE5—Si1025
 0xE6—Si1026
 0xE7—Si1027
 0xE8—Si1030
 0xE9—Si1031
 0xEA—Si1032
 0xEB—Si1033
 0xEC—Si1034
 0xED—Si1035
 0xEE—Si1036
 0xEF—Si1037

SFR Definition 18.1. DEVICEID: Device Identification

Bit	7	6	5	4	3	2	1	0
Name	DEVICEID[7:0]							
Type	R/W							
Reset	0	0	0	0	0	0	0	0

SFR Page = 0xF; SFR Address = 0xE9

Bit	Name	Function
7:0	DEVICEID[7:0]	Device Identification. These bits contain a value that can be decoded to determine the device part number.

SFR Definition 18.2. REVID: Revision Identification

Bit	7	6	5	4	3	2	1	0
Name	REVID[7:0]							
Type	R/W							
Reset	0	0	0	0	0	0	0	0

SFR Page = 0xF; SFR Address = 0xEA

Bit	Name	Function
7:0	REVID[7:0]	Revision Identification. These bits contain a value that can be decoded to determine the silicon revision. For example, 0x00 for Rev A and 0x01 for Rev B, etc.

18.5. Flash Write and Erase Guidelines

Any system which contains routines which write or erase flash memory from software involves some risk that the write or erase routines will execute unintentionally if the CPU is operating outside its specified operating range of VDD, system clock frequency, or temperature. This accidental execution of flash modifying code can result in alteration of flash memory contents causing a system failure that is only recoverable by re-Flashing the code in the device.

To help prevent the accidental modification of flash by firmware, the VDD Monitor must be enabled and enabled as a reset source on Si102x/3x devices for the flash to be successfully modified. **If either the VDD Monitor or the VDD Monitor reset source is not enabled, a Flash Error Device Reset will be generated when the firmware attempts to modify the flash.**

The following guidelines are recommended for any system that contains routines which write or erase flash from code.

18.5.1. VDD Maintenance and the VDD Monitor

1. If the system power supply is subject to voltage or current "spikes," add sufficient transient protection devices to the power supply to ensure that the supply voltages listed in the Absolute Maximum Ratings table are not exceeded.
2. Make certain that the minimum VDD rise time specification of 1 ms is met. If the system cannot meet this rise time specification, then add an external VDD brownout circuit to the $\overline{\text{RST}}$ pin of the device that holds the device in reset until VDD reaches the minimum device operating voltage and re-asserts $\overline{\text{RST}}$ if VDD drops below the minimum device operating voltage.
3. Keep the on-chip VDD Monitor enabled and enable the VDD Monitor as a reset source as early in code as possible. This should be the first set of instructions executed after the Reset Vector. For C-based systems, this will involve modifying the startup code added by the 'C' compiler. See your compiler documentation for more details. Make certain that there are no delays in software between enabling the VDD Monitor and enabling the VDD Monitor as a reset source. Code examples showing this can be found in "AN201: Writing to Flash from Firmware," available from the Silicon Laboratories web site.

Notes:

On Si102x/3x devices, both the VDD Monitor and the VDD Monitor reset source must be enabled to write or erase flash without generating a Flash Error Device Reset.

On Si102x/3x devices, both the VDD Monitor and the VDD Monitor reset source are enabled by hardware after a power-on reset.

4. As an added precaution, explicitly enable the VDD Monitor and enable the VDD Monitor as a reset source inside the functions that write and erase flash memory. The VDD Monitor enable instructions should be placed just after the instruction to set PSWE to a 1, but before the flash write or erase operation instruction.
5. Make certain that all writes to the RSTSRC (Reset Sources) register use direct assignment operators and explicitly DO NOT use the bit-wise operators (such as AND or OR). For example, "RSTSRC = 0x02" is correct, but "RSTSRC |= 0x02" is incorrect.
6. Make certain that all writes to the RSTSRC register explicitly set the PORSF bit to a '1'. Areas to check are initialization code which enables other reset sources, such as the Missing Clock Detector or Comparator, for example, and instructions which force a Software Reset. A global search on "RSTSRC" can quickly verify this.

18.5.2. PSWE Maintenance

1. Reduce the number of places in code where the PSWE bit (b0 in PSCTL) is set to a 1. There should be exactly one routine in code that sets PSWE to a 1 to write flash bytes and one routine in code that sets both PSWE and PSEE both to a 1 to erase flash pages.
2. Minimize the number of variable accesses while PSWE is set to a 1. Handle pointer address updates and loop maintenance outside the "PSWE = 1;... PSWE = 0;" area. Code examples showing this can be found in "AN201: Writing to Flash from Firmware," available from the Silicon Laboratories web site.
3. Disable interrupts prior to setting PSWE to a 1 and leave them disabled until after PSWE has been reset to 0. Any interrupts posted during the flash write or erase operation will be serviced in priority order after the flash operation has been completed and interrupts have been re-enabled by software.
4. Make certain that the flash write and erase pointer variables are not located in XRAM. See your compiler documentation for instructions regarding how to explicitly locate variables in different memory areas.
5. Add address bounds checking to the routines that write or erase flash memory to ensure that a routine called with an illegal address does not result in modification of the flash.

18.5.3. System Clock

1. If operating from an external crystal, be advised that crystal performance is susceptible to electrical interference and is sensitive to layout and to changes in temperature. If the system is operating in an electrically noisy environment, use the internal oscillator or use an external CMOS clock.
2. If operating from the external oscillator, switch to the internal oscillator during flash write or erase operations. The external oscillator can continue to run, and the CPU can switch back to the external oscillator after the flash operation has completed.

Additional flash recommendations and example code can be found in "AN201: Writing to Flash from Firmware," available from the Silicon Laboratories website.

18.6. Minimizing Flash Read Current

The flash memory in the Si102x/3x devices is responsible for a substantial portion of the total digital supply current when the device is executing code. Below are suggestions to minimize flash read current.

1. Use idle, low power idle, suspend, or sleep modes while waiting for an interrupt, rather than polling the interrupt flag. Idle mode and low power idle mode is particularly well-suited for use in implementing short pauses, since the wake-up time is no more than three system clock cycles. See the Power Management chapter for details on the various low-power operating modes.
2. The flash memory is organized in 4-byte words starting with a byte with address ending in 00b and ending with a byte with address ending in 11b. A 4-byte pre-fetch buffer is used to read 4 bytes of flash in a single read operation. Short loops that straddle word boundaries or have an instruction byte with address ending in 11b should be avoided when possible. If a loop executes in 20 or more clock cycles, any resulting increase in operating current due to mis-alignment will be negligible.
3. To minimize the power consumption of small loops, it is best to locate them such that the number of 4-byte words to be fetched from flash is minimized. Consider a 2-byte, 3-cycle loop (e.g., SJMP \$, or while(1);). The flash read current of such a loop will be minimized if both address bytes are contained in the first 3 bytes of a single 4-byte word. Such a loop should be manually located at an address ending in 00b or the number of bytes in the loop should be increased (by padding with NOP instructions) in order to minimize flash read current.

Si102x/3x

SFR Definition 18.3. PSCTL: Program Store R/W Control

Bit	7	6	5	4	3	2	1	0
Name							PSEE	PSWE
Type	R	R	R	R	R	R	R/W	R/W
Reset	0	0	0	0	0	0	0	0

SFR Page =All Pages; SFR Address = 0x8F

Bit	Name	Function
7:2	Unused	Read = 000000b, Write = don't care.
1	PSEE	Program Store Erase Enable. Setting this bit (in combination with PSWE) allows an entire page of flash program memory to be erased. If this bit is logic 1 and flash writes are enabled (PSWE is logic 1), a write to flash memory using the MOVX instruction will erase the entire page that contains the location addressed by the MOVX instruction. The value of the data byte written does not matter. 0: Flash program memory erasure disabled. 1: Flash program memory erasure enabled.
0	PSWE	Program Store Write Enable. Setting this bit allows writing a byte of data to the flash program memory using the MOVX write instruction. The flash location should be erased before writing data. 0: Writes to flash program memory disabled. 1: Writes to flash program memory enabled; the MOVX write instruction targets flash memory.

SFR Definition 18.4. FLKEY: Flash Lock and Key

Bit	7	6	5	4	3	2	1	0
Name	FLKEY[7:0]							
Type	R/W							
Reset	0	0	0	0	0	0	0	0

SFR Page = All Pages; SFR Address = 0xB7

Bit	Name	Function
7:0	FLKEY[7:0]	<p>Flash Lock and Key Register.</p> <p>Write: This register provides a lock and key function for flash erasures and writes. Flash writes and erases are enabled by writing 0xA5 followed by 0xF1 to the FLKEY register. Flash writes and erases are automatically disabled after the next write or erase is complete. If any writes to FLKEY are performed incorrectly, or if a flash write or erase operation is attempted while these operations are disabled, the flash will be permanently locked from writes or erasures until the next device reset. If an application never writes to flash, it can intentionally lock the flash by writing a non-0xA5 value to FLKEY from software.</p> <p>Read: When read, bits 1–0 indicate the current flash lock state. 00: Flash is write/erase locked. 01: The first key code has been written (0xA5). 10: Flash is unlocked (writes/erases allowed). 11: Flash writes/erases disabled until the next reset.</p>

Si102x/3x

SFR Definition 18.5. FL_SCL: Flash Scale

Bit	7	6	5	4	3	2	1	0
Name		BYPASS						
Type	R	R/W	R	R	R	R	R	R
Reset	0	0	0	0	0	0	0	0

SFR Page = All Pages; SFR Address = 0xB7

Bit	Name	Function
7	Reserved	Always Write to 0.
6	BYPASS	Flash Read Timing One-Shot Bypass. 0: The one-shot determines the flash read time. 1: The system clock determines the flash read time. Leaving the one-shot enabled will provide the lowest power consumption up to 25 MHz.
5:0	Reserved	Always Write to 000000.

Note: Operations which clear the BYPASS bit do not need to be immediately followed by a benign 3-byte instruction. For code compatibility with C8051F930/31/20/21 devices, a benign 3-byte instruction whose third byte is a don't care should follow the clear operation. See the C8051F93x-C8051F92x data sheet for more details.

SFR Definition 18.6. FLWR: Flash Write Only

Bit	7	6	5	4	3	2	1	0
Name	FLWR[7:0]							
Type	W							
Reset	0	0	0	0	0	0	0	0

SFR Page = 0x0; SFR Address = 0xE5

Bit	Name	Function
7:0	FLWR[7:0]	Flash Write Only. All writes to this register have no effect on system operation.

SFR Definition 18.7. FRBCN: Flash Read Buffer Control

Bit	7	6	5	4	3	2	1	0
Name							FRBD	CHBLKW
Type	R	R	R	R	R	R	R/W	R/W
Reset	0	0	1	0	0	0	0	0

SFR Page = 0xF; SFR Address = 0xB5

Bit	Name	Function
7:2	Unused	Read = 000000b. Write = don't care.
1	FRBD	Flash Read Buffer Disable Bit. 0: Flash read buffer is enabled and being used. 1: Flash read buffer is disabled and bypassed.
0	CHBLKW	Block Write Enable Bit. This bit allows block writes to flash memory from firmware. 0: Each byte of a software flash write is written individually. 1: Flash bytes are written in groups of four.

19. Power Management

Si102x/3x devices support 6 power modes: Normal, Idle, Stop, Low Power Idle, Suspend, and Sleep. The power management unit (PMU0) allows the device to enter and wake-up from the available power modes. A brief description of each power mode is provided in Table 19.1. Detailed descriptions of each mode can be found in the following sections.

Table 19.1. Power Modes

Power Mode	Description	Wake-Up Sources	Power Savings
Normal	Device fully functional	N/A	Excellent MIPS/mW
Idle	All peripherals fully functional. Very easy to wake up.	Any Interrupt.	Good No Code Execution
Stop	Legacy 8051 low power mode. A reset is required to wake up.	Any Reset.	Good No Code Execution Precision Oscillator Disabled
Low Power Idle	Improved Idle mode that uses clock gating to save power.	Any Interrupt	Very Good No Code Execution Selective Clock Gating
Suspend	Similar to Stop Mode, but very fast wake-up time and code resumes execution at the next instruction.	SmaRTClock, Port Match, Comparator0, $\overline{\text{RST}}$ pin, Pulse Counter VBAT Monitor.	Very Good No Code Execution All Internal Oscillators Disabled System Clock Gated
Sleep	Ultra Low Power and flexible wake-up sources. Code resumes execution at the next instruction.	SmaRTClock, Port Match, Comparator0, $\overline{\text{RST}}$ pin, Pulse Counter VBAT Monitor.	Excellent Power Supply Gated All Oscillators except SmaRTClock Disabled

In battery powered systems, the system should spend as much time as possible in sleep mode in order to preserve battery life. When a task with a fixed number of clock cycles needs to be performed, the device should switch to normal mode, finish the task as quickly as possible, and return to sleep mode. Idle mode, low power idle mode, and suspend mode provide a very fast wake-up time; however, the power savings in these modes will not be as much as in sleep Mode. Stop Mode is included for legacy reasons; the system will be more power efficient and easier to wake up when idle, low power idle, suspend, or sleep mode is used.

Although switching power modes is an integral part of power management, enabling/disabling individual peripherals as needed will help lower power consumption in all power modes. Each analog peripheral can be disabled when not in use or placed in a low power mode. Digital peripherals such as timers or serial busses draw little power whenever they are not in use. Digital peripherals draw no power in Sleep Mode.

19.1. Normal Mode

The MCU is fully functional in Normal Mode. Figure 19.1 shows the on-chip power distribution to various peripherals. There are three supply voltages powering various sections of the chip: VBAT, DCOOUT, and the 1.8 V internal core supply (output of VREG0). All analog peripherals are directly powered from the VBAT pin. All digital peripherals and the CIP-51 core are powered from the 1.8 V internal core supply (output of VREG0). The Pulse counter, RAM, PMU0, and the SmarTClock are powered from the internal core supply when the device is in normal mode. The input to VREG0 is controlled by software and depends on the settings of the power select switch. The power select switch may be configured to power VREG0 from VBAT or from the output of the DC0.

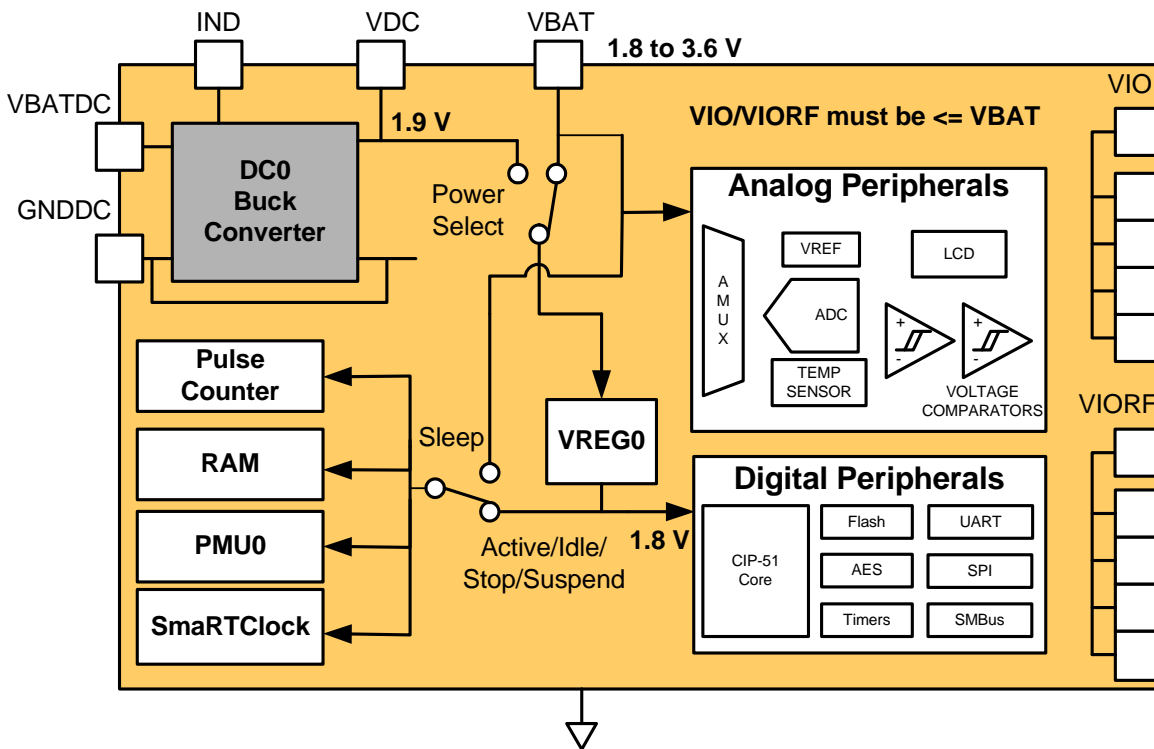

Figure 19.1. Si102x/3x Power Distribution

19.2. Idle Mode

Setting the Idle Mode Select bit (PCON.0) causes the CIP-51 to halt the CPU and enter Idle mode as soon as the instruction that sets the bit completes execution. All internal registers and memory maintain their original data. All analog and digital peripherals can remain active during Idle mode.

Idle mode is terminated when an enabled interrupt is asserted or a reset occurs. The assertion of an enabled interrupt will cause the Idle Mode Selection bit (PCON.0) to be cleared and the CPU to resume operation. The pending interrupt will be serviced and the next instruction to be executed after the return from interrupt (RETI) will be the instruction immediately following the one that set the Idle Mode Select bit. If Idle mode is terminated by an internal or external reset, the CIP-51 performs a normal reset sequence and begins program execution at address 0x0000.

If enabled, the Watchdog Timer (WDT) will eventually cause an internal watchdog reset and thereby terminate the Idle mode. This feature protects the system from an unintended permanent shutdown in the event

Si102x/3x

of an inadvertent write to the PCON register. If this behavior is not desired, the WDT may be disabled by software prior to entering the idle mode if the WDT was initially configured to allow this operation. This provides the opportunity for additional power savings, allowing the system to remain in the Idle mode indefinitely, waiting for an external stimulus to wake up the system. Refer to Section “22.6. PCA Watchdog Timer Reset” on page 290 for more information on the use and configuration of the WDT.

19.3. Stop Mode

Setting the Stop Mode Select bit (PCON.1) causes the CIP-51 to enter Stop mode as soon as the instruction that sets the bit completes execution. In Stop mode the precision internal oscillator and CPU are stopped; the state of the low power oscillator and the external oscillator circuit is not affected. Each analog peripheral (including the external oscillator circuit) may be shut down individually prior to entering Stop Mode. Stop mode can only be terminated by an internal or external reset. On reset, the CIP-51 performs the normal reset sequence and begins program execution at address 0x0000.

If enabled, the Missing Clock Detector will cause an internal reset and thereby terminate the Stop mode. The Missing Clock Detector should be disabled if the CPU is to be put in STOP mode for longer than the MCD timeout.

Stop Mode is a legacy 8051 power mode; it will not result in optimal power savings. Sleep, Suspend, or Low Power Idle mode will provide more power savings if the MCU needs to be inactive for a long period of time.

19.4. Low Power Idle Mode

Low Power Idle Mode uses clock gating to reduce the supply current when the device is placed in Idle mode. This mode is enabled by configuring the clock tree gates using the PCLKEN register, setting the LPMEN bit in the CLKMODE register, and placing the device in Idle mode. The clock is automatically gated from the CPU upon entry into Idle mode when the LPMEN bit is set. This mode provides substantial power savings over the standard Idle Mode especially at high system clock frequencies.

The clock gating logic may also be used to reduce power when executing code. Low Power Active Mode is enabled by configuring the PCLKACT and PCLKEN registers, then setting the LPMEN bit. The PCLKACT register provides the ability to override the PCLKEN setting to force a clock to certain peripherals in Low Power Active mode. If the PCLKACT register is left at its default value, then PCLKEN determines which peripherals will be clocked in this mode. The CPU is always clocked in Low Power Active Mode.

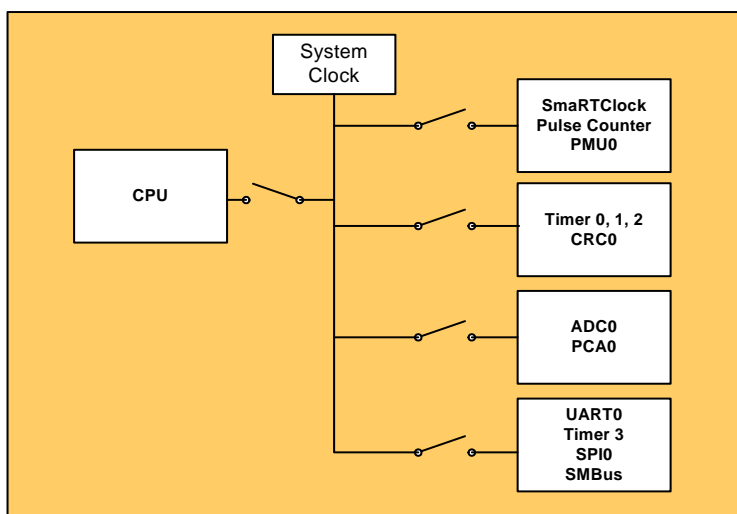

Figure 19.2. Clock Tree Distribution

SFR Definition 19.1. PCLKACT: Peripheral Active Clock Enable

Bit	7	6	5	4	3	2	1	0
Name	PCLKACT[3:0]							
Type	R/W	R/W	R/W	R/W	R/W			
Reset	0	0	0	0	0	0	0	0

SFR Page = 0xF; SFR Address = 0xF5

Bit	Name	Function
7:4	Unused	Read = 0b; Write = don't care.
3	PCLKACT3	Clock Enable Controls for Peripherals in Low Power Active Mode. 0: Clocks to the SmarTClock, Pulse Counter, and PMU0 revert to the PCLKEN setting in Low Power Active Mode. 1: Enable clocks to the SmarTClock, Pulse Counter, and PMU0 in Low Power Active Mode.
2	PCLKACT2	Clock Enable Controls for Peripherals in Low Power Active Mode. 0: Clocks to Timer 0, Timer 1, Timer 2, and CRC0 revert to the PCLKEN setting in Low Power Active Mode. 1: Enable clocks to Timer 0, Timer 1, Timer 2, and CRC0 in Low Power Active Mode.
1	PCLKACT1	Clock Enable Controls for Peripherals in Low Power Active Mode. 0: Clocks to ADC0 and PCA0 revert to the PCLKEN setting in Low Power Active Mode. 1: Enable clocks to ADC0 and PCA0 in Low Power Active Mode.
0	PCLKACT0	Clock Enable Controls for Peripherals in Low Power Active Mode. 0: Clocks to UART0, Timer 3, SPI0, and the SMBus revert to the PCLKEN setting in Low Power Active Mode. 1: Enable clocks to UART0, Timer 3, SPI0, and the SMBus in Low Power Active Mode.

Si102x/3x

SFR Definition 19.2. PCLKEN: Peripheral Clock Enable

Bit	7	6	5	4	3	2	1	0
Name	PCLKEN[3:0]							
Type	R/W	R/W	R/W	R/W	R/W			
Reset								

SFR Page = 0xF; SFR Address = 0xFE

Bit	Name	Function
7:4	Unused	Read = 0b; Write = don't care.
3	PCLKEN3	Clock Enable Controls for Peripherals in Low Power Idle Mode. 0: Disable clocks to the SmarTClock, Pulse Counter, and PMU0 in Low Power Idle Mode. 1: Enable clocks to the SmarTClock, Pulse Counter, and PMU0 in Low Power Idle Mode.
2	PCLKEN2	Clock Enable Controls for Peripherals in Low Power Idle Mode. 0: Disable clocks to Timer 0, Timer 1, Timer 2, and CRC0 in Low Power Idle Mode. 1: Enable clocks to Timer 0, Timer 1, Timer 2, and CRC0 in Low Power Idle Mode.
1	PCLKEN1	Clock Enable Controls for Peripherals in Low Power Idle Mode. 0: Disable clocks to ADC0 and PCA0 in Low Power Idle Mode. 1: Enable clocks to ADC0 and PCA0 in Low Power Idle Mode.
0	PCLKEN0	Clock Enable Controls for Peripherals in Low Power Idle Mode. 0: Disable clocks to UART0, Timer 3, SPI0, and the SMBus in Low Power Idle Mode. 1: Enable clocks to UART0, Timer 3, SPI0, and the SMBus in Low Power Idle Mode.

SFR Definition 19.3. CLKMODE: Clock Mode

Bit	7	6	5	4	3	2	1	0
Name	Reserved	Reserved	Reserved	Reserved	Reserved	LPMEN	Reserved	Reserved
Type	R/W	R/W	R/W	R/W	R/W	R/W	R/W	R/W
Reset	0	0	0	0	0	0	0	0

SFR Page = 0xF; SFR Address = 0xFD; Bit-Addressable

Bit	Name	Function
7:3	Reserved	Read = 0b; Write = Must write 00000b.
2	LPMEN	Low Power Mode Enable. Setting this bit allows the device to enter Low Power Active or Idle Mode.
1	Reserved	Read = 0b; Must write 0b.
0	Reserved	Read = 0b; Must write 0b.

19.5. Suspend Mode

Setting the Suspend Mode Select bit (PMU0CF.6) causes the system clock to be gated off and all internal oscillators disabled. The system clock source must be set to the low power internal oscillator or the precision oscillator prior to entering Suspend Mode. All digital logic (timers, communication peripherals, interrupts, CPU, etc.) stops functioning until one of the enabled wake-up sources occurs.

The following wake-up sources can be configured to wake the device from Suspend Mode:

- Pulse Counter Count Reached Event
- VBAT Monitor (part of LCD logic)
- SmarTClock Oscillator Fail
- SmarTClock Alarm
- Port Match Event
- Comparator0 Rising Edge

Note: Upon wake-up from suspend mode, PMU0 requires two system clocks in order to update the PMU0CF wake-up flags. All flags will read back a value of '0' during the first two system clocks following a wake-up from suspend mode.

In addition, a noise glitch on $\overline{\text{RST}}$ that is not long enough to reset the device will cause the device to exit suspend. In order for the MCU to respond to the pin reset event, software must not place the device back into suspend mode for a period of 15 μs . The PMU0CF register may be checked to determine if the wake-up was due to a falling edge on the $\overline{\text{RST}}$ pin. If the wake-up source is not due to a falling edge on $\overline{\text{RST}}$, there is no time restriction on how soon software may place the device back into suspend mode. A 4.7 k Ω pullup resistor to VDD is recommend for RST to prevent noise glitches from waking the device.

19.6. Sleep Mode

Setting the Sleep Mode Select bit (PMU0CF.7) turns off the internal 1.8 V regulator (VREG0) and switches the power supply of all on-chip RAM to the VBAT pin (see Figure 19.1). Power to most digital logic on the chip is disconnected; only PMU0, LCD, Power Select Switch, Pulse Counter, and the SmarTClock remain powered. Analog peripherals remain powered; however, only the Comparators remain functional when the device enters Sleep Mode. All other analog peripherals (ADC0, IREF0, External Oscillator, etc.) should be disabled prior to entering Sleep Mode. The system clock source must be set to the low power internal oscillator or the precision oscillator prior to entering Sleep Mode.

GPIO pins configured as digital outputs will retain their output state during sleep mode. In two-cell mode, they will maintain the same current drive capability in sleep mode as they have in normal mode.

GPIO pins configured as digital inputs can be used during sleep mode as wakeup sources using the port match feature. In two-cell mode, they will maintain the same input level specs in sleep mode as they have in normal mode.

'Si102x/3x devices support a wakeup request for external devices. Upon exit from sleep mode, the wake-up request signal is driven low, allowing other devices in the system to wake up from their low power modes.

RAM and SFR register contents are preserved in sleep mode as long as the voltage on VBAT does not fall below V_{POR} . The PC counter and all other volatile state information is preserved allowing the device to resume code execution upon waking up from Sleep mode.

The following wake-up sources can be configured to wake the device from sleep mode:

- Pulse Counter Count Reached Event
- VBAT Monitor (part of LCD logic)
- SmarTClock Oscillator Fail
- SmarTClock Alarm
- Port Match Event
- Comparator0 Rising Edge

The comparator requires a supply voltage of at least 1.8 V to operate properly. On Si102x/3x devices, the POR supply monitor can be disabled to save power by writing 1 to the MONDIS (PMU0MD.5) bit. When the POR supply monitor is disabled, all reset sources will trigger a full POR and will re-enable the POR supply monitor.

In addition, any falling edge on $\overline{\text{RST}}$ (due to a pin reset or a noise glitch) will cause the device to exit sleep mode. In order for the MCU to respond to the pin reset event, software must not place the device back into sleep mode for a period of 15 μs . The PMU0CF register may be checked to determine if the wake-up was due to a falling edge on the $\overline{\text{RST}}$ pin. If the wake-up source is not due to a falling edge on $\overline{\text{RST}}$, there is no time restriction on how soon software may place the device back into sleep mode. A 4.7 k Ω pullup resistor to VDD is recommend for $\overline{\text{RST}}$ to prevent noise glitches from waking the device.

19.7. Configuring Wakeup Sources

Before placing the device in a low power mode, one or more wakeup sources should be enabled so that the device does not remain in the low power mode indefinitely. For idle mode, this includes enabling any interrupt. For stop mode, this includes enabling any reset source or relying on the $\overline{\text{RST}}$ pin to reset the device.

Wake-up sources for suspend and sleep modes are configured through the PMU0CF register. Wake-up sources are enabled by writing 1 to the corresponding wake-up source enable bit. Wake-up sources must be re-enabled each time the device is placed in Suspend or Sleep mode, in the same write that places the device in the low power mode.

The reset pin is always enabled as a wake-up source. On the falling edge of $\overline{\text{RST}}$, the device will be awoken from sleep mode. The device must remain awake for more than 15 μs in order for the reset to take place.

19.8. Determining the Event that Caused the Last Wakeup

When waking from idle mode, the CPU will vector to the interrupt which caused it to wake up. When waking from stop mode, the RSTSRC register may be read to determine the cause of the last reset.

Upon exit from suspend or sleep mode, the wake-up flags in the PMU0CF register can be read to determine the event which caused the device to wake up. After waking up, the wake-up flags will continue to be updated if any of the wake-up events occur. Wake-up flags are always updated, even if they are not enabled as wake-up sources.

All wake-up flags enabled as wake-up sources in PMU0CF must be cleared before the device can enter suspend or sleep mode. After clearing the wake-up flags, each of the enabled wake-up events should be checked in the individual peripherals to ensure that a wake-up event did not occur while the wake-up flags were being cleared.

Si102x/3x

SFR Definition 19.4. PMU0CF: Power Management Unit Configuration^{1,2,3}

Bit	7	6	5	4	3	2	1	0
Name	SLEEP	SUSPEND	CLEAR	RSTWK	RTCFWK	RTCAWK	PMATWK	CPT0WK
Type	W	W	W	R	R/W	R/W	R/W	R/W
Reset	0	0	0	Varies	Varies	Varies	Varies	Varies

SFR Page = 0x0; SFR Address = 0xB5

Bit	Name	Description	Write	Read
7	SLEEP	Sleep Mode Select	Writing 1 places the device in Sleep Mode.	N/A
6	SUSPEND	Suspend Mode Select	Writing 1 places the device in Suspend Mode.	N/A
5	CLEAR	Wake-up Flag Clear	Writing 1 clears all wake-up flags.	N/A
4	RSTWK	Reset Pin Wake-up Flag	N/A	Set to 1 if a falling edge has been detected on <u>RST</u> .
3	RTCFWK	SmaRTClock Oscillator Fail Wake-up Source Enable and Flag	0: Disable wake-up on SmaRTClock Osc. Fail. 1: Enable wake-up on SmaRTClock Osc. Fail.	Set to 1 if the SmaRTClock Oscillator has failed.
2	RTCAWK	SmaRTClock Alarm Wake-up Source Enable and Flag	0: Disable wake-up on SmaRTClock Alarm. 1: Enable wake-up on SmaRTClock Alarm.	Set to 1 if a SmaRTClock Alarm has occurred.
1	PMATWK	Port Match Wake-up Source Enable and Flag	0: Disable wake-up on Port Match Event. 1: Enable wake-up on Port Match Event.	Set to 1 if a Port Match Event has occurred.
0	CPT0WK	Comparator0 Wake-up Source Enable and Flag	0: Disable wake-up on Comparator0 rising edge. 1: Enable wake-up on Comparator0 rising edge.	Set to 1 if Comparator0 rising edge has occurred.

Notes:

1. Read-modify-write operations (ORL, ANL, etc.) should not be used on this register. Wake-up sources must be re-enabled each time the SLEEP or SUSPEND bits are written to 1.
2. The Low Power Internal Oscillator cannot be disabled and the MCU cannot be placed in Suspend or Sleep Mode if any wake-up flags are set to 1. Software should clear all wake-up sources after each reset and after each wake-up from Suspend or Sleep Modes.
3. PMU0 requires two system clocks to update the wake-up source flags after waking from Suspend mode. The wake-up source flags will read '0' during the first two system clocks following the wake from Suspend mode.

SFR Definition 19.5. PMU0FL: Power Management Unit Flag^{1,2}

Bit	7	6	5	4	3	2	1	0
Name						BATMWK	Reserved	PC0WK
Type	R	R	R	R	R	R/W	R/W	R/W
Reset	0	0	0	0	0	0	0	Varies

SFR Page = 0x0; SFR Address = 0xB6

Bit	Name	Description	Write	Read
7:3	Unused	Unused	Don't Care.	0000000
2	BATMWK	VBAT Monitor (inside LCD Logic) Wake-up Source Enable and Flag	0: Disable wake-up on VBAT Monitor event. 1: Enable wake-up on CS0 event.	Set to 1 if VBAT Monitor event caused the last wake-up.
1	Reserved	Reserved	Must write 0.	Always reads 0.
0	CS0WK	Pulse Counter Wake-up Source Enable and Flag	0: Disable wake-up on PC0 event. 1: Enable wake-up on PC0 event.	Set to 1 if PC0 event caused the last wake-up.

Notes:

1. The Low Power Internal Oscillator cannot be disabled and the MCU cannot be placed in suspend or sleep mode if any wake-up flags are set to 1. Software should clear all wake-up sources after each reset and after each wake-up from Suspend or Sleep Modes.
2. PMU0 requires two system clocks to update the wake-up source flags after waking from suspend mode. The wake-up source flags will read 0 during the first two system clocks following the wake from suspend mode.

Si102x/3x

SFR Definition 19.6. PMU0MD: Power Management Unit Mode

Bit	7	6	5	4	3	2	1	0
Name	RTCOE	WAKEOE	MONDIS					
Type	R/W	R/W	R/W	R/W	R/W	R/W	R/W	R/W
Reset	0	0	0	0	0	0	0	0

SFR Page = 0x0; SFR Address = 0xB6

Bit	Name	Function
7	RTCOE	Buffered SmarTclock Output Enable. Enables the buffered SmarTclock oscillator output on P0.2. 0: Buffered SmarTclock output not enabled. 1: Buffered SmarTclock output not enabled.
6	WAKEOE	Wakeup Request Output Enable. Enables the Sleep Mode wake-up request signal on P0.3. 0: Wake-up request signal is not enabled. 1: Wake-up request signal is enabled.
5	MONDIS	POR Supply Monitor Disable. Writing a 1 to this bit disables the POR supply monitor.
4:0	Unused	Read = 00000b. Write = Don't Care.

SFR Definition 19.7. PCON: Power Management Control Register

Bit	7	6	5	4	3	2	1	0
Name	GF[4:0]					PWRSEL	STOP	IDLE
Type	R/W					R/W	W	W
Reset	0	0	0	0	0	0	0	0

SFR Page = All Pages; SFR Address = 0x87

Bit	Name	Description	Write	Read
7:3	GF[5:0]	General Purpose Flags	Sets the logic value.	Returns the logic value.
2	PWRSEL	Power Select	0: VBAT is selected as the input to VREG0. 1: VDC is selected as the input to VREG0.	
1	STOP	Stop Mode Select	Writing 1 places the device in Stop Mode.	N/A
0	IDLE	Idle Mode Select	Writing 1 places the device in Idle Mode.	N/A

19.9. Power Management Specifications

See Table 4.7 on page 61 for detailed Power Management Specifications.

20. On-Chip DC-DC Buck Converter (DC0)

Si102x/3x devices include an on-chip step down dc-dc converter to efficiently utilize the energy stored in the battery, thus extending the operational life time. The dc-dc converter is a switching buck converter with an input supply of 1.8 to 3.8 V and an output that is programmable from 1.8 to 3.5 V in steps of 0.1 V. The battery voltage should be at least 0.4 V higher than the programmed output voltage. The programmed output voltage has a default value of 1.9 V. The dc-dc converter can supply up to 250 mW. The dc-dc converter can be used to power the MCU and/or external devices in the system (e.g., an RF transceiver).

The dc-dc converter has a built in voltage reference and oscillator, and will automatically limit or turn off the switching activity in case the peak inductor current rises beyond a safe limit or the output voltage rises above the programmed target value. This allows the dc-dc converter output to be safely overdriven by a secondary power source (when available) in order to preserve battery life. When enabled, the dc-dc converter can source current into the output capacitor, but cannot sink current. The dc-dc converter's settings can be modified using SFR registers described in Section 20.8.

Figure 20.1 shows a block diagram of the buck converter.

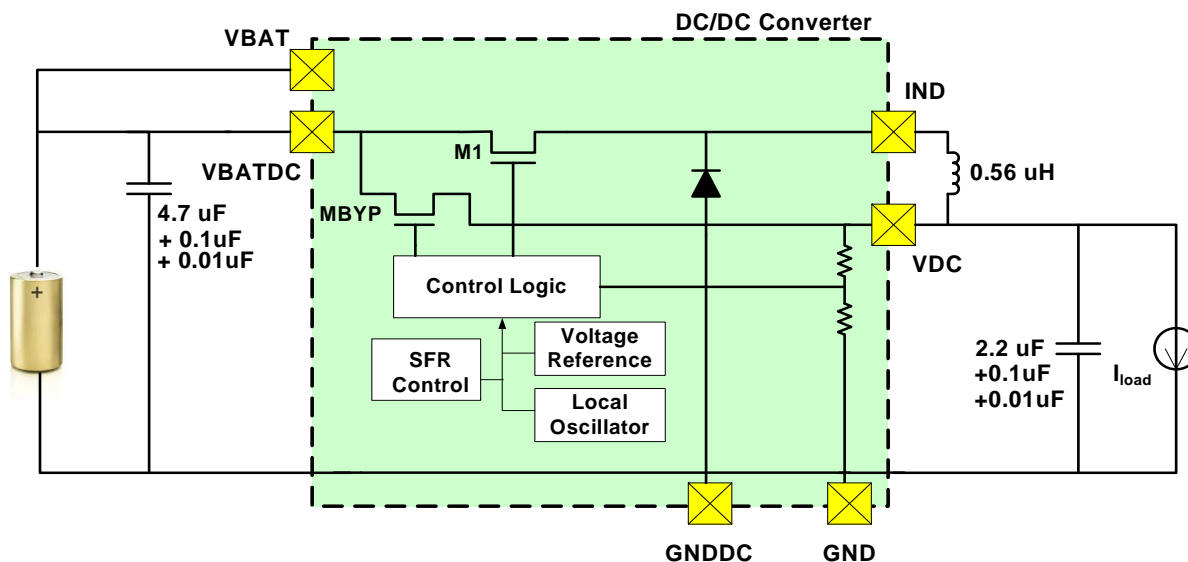

Figure 20.1. Step Down DC-DC Buck Converter Block Diagram

20.1. Startup Behavior

The dc-dc converter is enabled by setting bit DC0EN (DC0MD.0) to logic 1. When first enabled, the M1 switch turns on and continues to supply current into the output capacitor through the inductor until the VDC output voltage reaches the programmed level set by the VSEL bits (DC0CF.[6:3]).

The peak transient current in the inductor is limited for safe operation. The peak inductor current is programmable using the ILIMIT bits (DC0MD.[6:4]). The peak inductor current, size of the output capacitor and the amount of dc load current present during startup will determine the length of time it takes to charge the output capacitor. The RDYH and RDYL bits (DC0RDY.7 and DC0DRY.6) may be used to determine when the output voltage is within approximately 100 mV of the programmed voltage.

In order to ensure reliable startup of the dc-dc converter, the following restrictions have been imposed:

- The maximum dc load current allowed during startup is given in Table 4.20 on page 69. If the dc-dc converter is powering external sensors or devices through the VDC pin, then the current supplied to these sensors or devices is counted towards this limit. The in-rush current into capacitors does not count towards this limit.
- The maximum total output capacitance is given in Table 4.20 on page 69. This value includes the required 2.2 μ F ceramic output capacitor and any additional capacitance connected to the VDC pin.

The peak inductor current limit is programmable by software as shown in Table 20.1. Limiting the peak inductor current can allow the dc-dc converter to start up using a high impedance power source (such as when a battery is near its end of life) or allow inductors with a low current rating to be utilized. By default, the peak inductor current is set to 500 mA.

Table 20.1. IPeak Inductor Current Limit Settings

ILIMIT	Peak Current (mA)
001	200
010	300
011	400
100	500
101	600

The peak inductor current is dependent on several factors including the dc load current and can be estimated using following equation:

$$I_{PK} = \frac{2 \times I_{LOAD} \times (VDC - VBATDC)}{\text{efficiency} \times \text{inductance} \times \text{frequency}}$$

efficiency = 0.80

inductance = 0.68 μ H

frequency = 2.4 MHz

Si102x/3x

20.2. High Power Applications

The dc-dc converter is designed to provide the system with 150 mW of output power. At high output power, an inductor with low DC resistance should be chosen in order to minimize power loss and maximize efficiency. At load currents higher than 20 mA, efficiency improvements may be achieved by placing a schottky diode (e.g. MBR052LT1) between the IND pin and GND in parallel with the internal diode (see Figure 20.1).

20.3. Pulse Skipping Mode

The dc-dc converter allows the user to set the minimum pulse width such that if the duty cycle needs to decrease below a certain width in order to maintain regulation, an entire "clock pulse" will be skipped.

Pulse skipping can provide substantial power savings, particularly at low values of load current. The converter will continue to maintain a minimum output voltage at its programmed value when pulse skipping is employed, though the output voltage ripple can be higher. Another consideration is that the dc-dc will operate with pulse-frequency modulation rather than pulse-width modulation, which makes the switching frequency spectrum less predictable; this could be an issue if the dc-dc converter is used to power a radio.

20.4. Optimizing Board Layout

The PCB layout does have an effect on the overall efficiency. The following guidelines are recommended to achieve the optimum layout:

- Place the input capacitor stack as close as possible to the VBATDC pin. The smallest capacitors in the stack should be placed closest to the VBATDC pin.
- Place the output capacitor stack as close as possible to the VDC pin. The smallest capacitors in the stack should be placed closest to the VDC pin.
- Minimize the trace length between the IND pin, the inductor, and the VDC pin.

20.5. Selecting the Optimum Switch Size

The dc-dc converter provides the ability to change the size of the built-in switches. To maximize efficiency, one of two switch sizes may be selected. The large switches are ideal for carrying high currents and the small switches are ideal for low current applications. The ideal switchover point to switch from the small switches to the large switches is at approximately 5 mA total output current.

20.6. DC-DC Converter Clocking Options

The dc-dc converter may be clocked from its internal oscillator, or from any system clock source, selectable by the CLKSEL bit (DC0CF.0). The dc-dc converter internal oscillator frequency is approximately 2.4 MHz. For a more accurate clock source, the system clock, or a divided version of the system clock may be used as the dc-dc clock source. The dc-dc converter has a built in clock divider (configured using DC0CF[6:5]) which allows any system clock frequency over 1.6 MHz to generate a valid clock in the range of 1.9 to 3.8 MHz.

When the precision internal oscillator is selected as the system clock source, the OSCICL register may be used to fine tune the oscillator frequency and the dc-dc converter clock. The oscillator frequency should only be decreased since it is factory calibrated at its maximum frequency. The minimum frequency which can be reached by the oscillator after taking into account process variations is approximately 16 MHz. The system clock routed to the dc-dc converter clock divider also may be inverted by setting the CLKINV bit (DC0CF.3) to logic 1. These options can be used to minimize interference in noise sensitive applications.

20.7. Bypass Mode

The dc-dc converter has a bypass switch (MBYP), see Figure 20.1, which allows the output voltage (VDC) to be directly tied to the input supply (VBATDC), bypassing the dc-dc converter. The bypass switch may be used independently from the dc-dc converter. For example, applications that need to power the VDC supply in the lowest power Sleep mode can turn on the bypass switch prior to turning off the dc-dc converter in order to avoid powering down the external circuitry connected to VDC.

There are two ways to close the bypass switch. Using the first method, Forced Bypass Mode, the FORBYP bit is set to a logic 1 forcing the bypass switch to close. Clearing the FORBYP bit to logic 0 will allow the switch to open if it is not being held closed using Automatic Bypass Mode.

The Automatic Bypass Mode, enabled by setting the AUTOBYP to logic 1, closes the bypass switch when the difference between VBATDC and the programmed output voltage is less than approximately 0.4 V. Once the difference exceeds approximately 0.5 V, the bypass switch is opened unless being held closed by Forced Bypass Mode. In most systems, Automatic Bypass Mode will be left enabled, and the Forced Bypass Mode will be used to close the switch as needed by the system.

20.8. DC-DC Converter Register Descriptions

The SFRs used to configure the dc-dc converter are described in the following register descriptions.

SFR Definition 20.1. DC0CN: DC-DC Converter Control

Bit	7	6	5	4	3	2	1	0
Name	CLKSEL	CLKDIV[1:0]		AD0CKINV	CLKINV	ILIMIT	MIN_PW[1:0]	
Type	R	R/W	R/W	R/W	R/W	R/W	R/W	
Reset	0	0	0	0	0	0	1	1

SFR Page = 0x2; SFR Address = 0xB1

Bit	Name	Function
7	CLKSEL	DC-DC Converter Clock Source Select. Specifies the dc-dc converter clock source. 0: The dc-dc converter is clocked from its local oscillator. 1: The dc-dc converter is clocked from the system clock.
6:5	CLKDIV[1:0]	DC-DC Clock Divider. Divides the dc-dc converter clock when the system clock is selected as the clock source for dc-dc converter. Ignored all other times. 00: The dc-dc converter clock is system clock divided by 1. 01: The dc-dc converter clock is system clock divided by 2. 10: The dc-dc converter clock is system clock divided by 4. 11: The dc-dc converter clock is system clock divided by 8.
4	AD0CKINV	ADC0 Clock Inversion (Clock Invert During Sync). Inverts the ADC0 SAR clock derived from the dc-dc converter clock when the SYNC bit (DC0CN.3) is enabled. This bit is ignored when the SYNC bit is set to zero. 0: ADC0 SAR clock is inverted. 1: ADC0 SAR clock is not inverted.
3	CLKINV	DC-DC Converter Clock Invert. Inverts the system clock used as the input to the dc-dc clock divider. 0: The dc-dc converter clock is not inverted. 1: The dc-dc converter clock is inverted.
2	SYNC	ADC0 Synchronization Enable. When synchronization is enabled, the ADC0SC[4:0] bits in the ADC0CF register must be set to 00000b. 0: The ADC is not synchronized to the dc-dc converter. 1: The ADC is synchronized to the dc-dc converter. ADC0 tracking is performed during the longest quiet time of the dc-dc converter switching cycle and ADC0 SAR clock is also synchronized to the dc-dc converter switching cycle.
1:0	MINPW[1:0]	DC-DC Converter Minimum Pulse Width. Specifies the minimum pulse width. 00: Minimum pulse detection logic is disabled (no pulse skipping). 01: Minimum pulse width is 10 ns. 10: Minimum pulse width is 20 ns. 11: Minimum pulse width is 40 ns.

SFR Definition 20.2. DC0CF: DC-DC Converter Configuration

Bit	7	6	5	4	3	2	1	0	
Name	BYPASS	VSEL[3:0]				OSCDIS	SWSEL[1:0]		
Type	R	R/W				R/W			
Reset	0	0	0	0	1	0	1	1	

SFR Page = 0x2; SFR Address = 0xB2

Bit	Name	Function
7	BYPASS	DC-DC Converter Bypass Switch Active Indicator. 0: The bypass switch is open. 1: The bypass switch is closed (VDC is connected to VBATDC).
6:3	VSEL[3:0]	DC-DC Converter Output Voltage Select. Specifies the target output voltage. 0000: Target output voltage is 1.8 V. 1000: Target output voltage is 2.6 V. 0001: Target output voltage is 1.9 V. 1001: Target output voltage is 2.7 V. 0010: Target output voltage is 2.0 V. 1010: Target output voltage is 2.8 V. 0011: Target output voltage is 2.1 V. 1011: Target output voltage is 2.9 V. 0100: Target output voltage is 2.2 V. 1100: Target output voltage is 3.0 V. 0101: Target output voltage is 2.3 V. 1101: Target output voltage is 3.1 V. 0110: Target output voltage is 2.4 V. 1110: Target output voltage is 3.3 V. 0111: Target output voltage is 2.5 V. 1111: Target output voltage is 3.5 V.
2	VSEL[2:0]	DC-DC Converter Local Oscillator Disabled. 0: The local oscillator inside the dc-dc converter is enabled. 1: The local oscillator inside the dc-dc converter is disabled.
1:0	SWSEL[1:0]	DC-DC Converter Power Switch Select. Selects the size of the power switches (M1, M2). Using smaller switches will result in higher efficiency at low supply currents. 00: Minimum switch size, optimized for load currents smaller than 5 mA. 01: Reserved. 10: Reserved. 11: Maximum switch size, optimized for load currents greater than 5 mA.

SFR Definition 20.3. DC0MD: DC-DC Converter Mode

Bit	7	6	5	4	3	2	1	0
Name	Reserved	ILIMIT			FORBYP	AUTOBYP	Reserved	DC0EN
Type	R/W	R/W			R/W	R/W	R/W	R/W
Reset	0	1	0	0	0	0	0	0

SFR Page = 0x2; SFR Address = 0xB3

Bit	Name	Function
7	Reserved	Read = 0b; Must write 0b.
6:4	ILIMIT	Peak Current Limit Threshold. 000: Reserved 001: Peak Inductor current is limited to 200 mA 010: Peak Inductor current is limited to 300 mA 011: Peak Inductor current is limited to 400 mA 100: Peak Inductor current is limited to 500 mA 101: Peak Inductor current is limited to 600 mA 110: Reserved 111: Reserved
3	FORBYP	Enable Forced Bypass Mode. 0: Forced bypass mode is disabled. 1: Forced bypass mode is enabled.
2	AUTOBYP	Enable Automatic Bypass Mode. 0: Automatic Bypass mode is disabled. 1: Automatic bypass mode is enabled.
1	Reserved	Read = 1b; Must write 1b.
0	DC0EN	DC-DC Converter Enable. 0: DC-DC converter is disabled. 1: DC-DC converter is enabled.

SFR Definition 20.4. DC0RDY: DC-DC Converter Ready Indicator

Bit	7	6	5	4	3	2	1	0
Name	RDYH	RDYL	Reserved					
Type	R	R	R/W					
Reset	0	0	0	1	1	1	1	1

SFR Page = 0x2; SFR Address = 0xFD

Bit	Name	Function
7	RDYH	DC0 Ready Indicator (High Threshold). Indicates when VDC is 100 mV higher than the target output value. 0: VDC pin voltage is less than the DC0 High Threshold. 1: VDC pin voltage is higher than the DC0 High Threshold.
6	RDYL	DC0 Ready Indicator (Low Threshold). Indicates when VDC is 100 mV lower than the target output value. 0: VDC pin voltage is less than the DC0 Low Threshold. 1: VDC pin voltage is higher than the DC0 Low Threshold.
5:0	Reserved	Read = 011111b; Must write 011111b.

20.9. DC-DC Converter Specifications

See Table 4.20 on page 69 for a detailed listing of dc-dc converter specifications.

Si102x/3x

21. Voltage Regulator (VREG0)

Si102x/3x devices include an internal voltage regulator (VREG0) to regulate the internal core supply to 1.8 V from a VDD/DC+ supply of 1.8 to 3.6 V. Electrical characteristics for the on-chip regulator are specified in the Electrical Specifications chapter.

The REG0CN register allows the Precision Oscillator Bias to be disabled, reducing supply current in all non-sleep power modes. This bias should only be disabled when the precision oscillator is not being used.

The internal regulator (VREG0) is disabled when the device enters sleep mode and remains enabled when the device enters suspend mode. See Section “19. Power Management” on page 264 for complete details about low power modes.

SFR Definition 21.1. REG0CN: Voltage Regulator Control

Bit	7	6	5	4	3	2	1	0
Name				OSCBIAS				
Type	R/W	R/W	R/W	R/W	R/W	R/W	R/W	R/W
Reset	0	0	0	1	0	0	0	0

SFR Page = 0x0; SFR Address = 0xC9

Bit	Name	Function
7:5	Reserved	Read = 000b. Must Write 000b.
4	OSCBIAS	Precision Oscillator Bias. When set to 1, the bias used by the precision oscillator is forced on. If the precision oscillator is not being used, this bit may be cleared to 0 to to save supply current in all non-Sleep power modes.
3:0	Reserved	Read = 0000b. Must Write 0000b.

21.1. Voltage Regulator Electrical Specifications

See Table 4.17 on page 67 for detailed Voltage Regulator Electrical Specifications.

22. Reset Sources

Reset circuitry allows the controller to be easily placed in a predefined default condition. On entry to this reset state, the following occur:

- CIP-51 halts program execution
- Special Function Registers (SFRs) are initialized to their defined reset values
- External Port pins are forced to a known state
- Interrupts and timers are disabled

All SFRs are reset to the predefined values noted in the SFR descriptions. The contents of RAM are unaffected during a reset; any previously stored data is preserved as long as power is not lost. Since the stack pointer SFR is reset, the stack is effectively lost, even though the data on the stack is not altered.

The port I/O latches are reset to 0xFF (all logic ones) in open-drain mode. Weak pullups are enabled during and after the reset. For V_{DD} Monitor and power-on resets, the \overline{RST} pin is driven low until the device exits the reset state.

On exit from the reset state, the program counter (PC) is reset, and the system clock defaults to an internal oscillator. Refer to Section “23. Clocking Sources” on page 293 for information on selecting and configuring the system clock source. The Watchdog Timer is enabled with the system clock divided by 12 as its clock source (Section “34.4. Watchdog Timer Mode” on page 524 details the use of the Watchdog Timer). Program execution begins at location 0x0000.

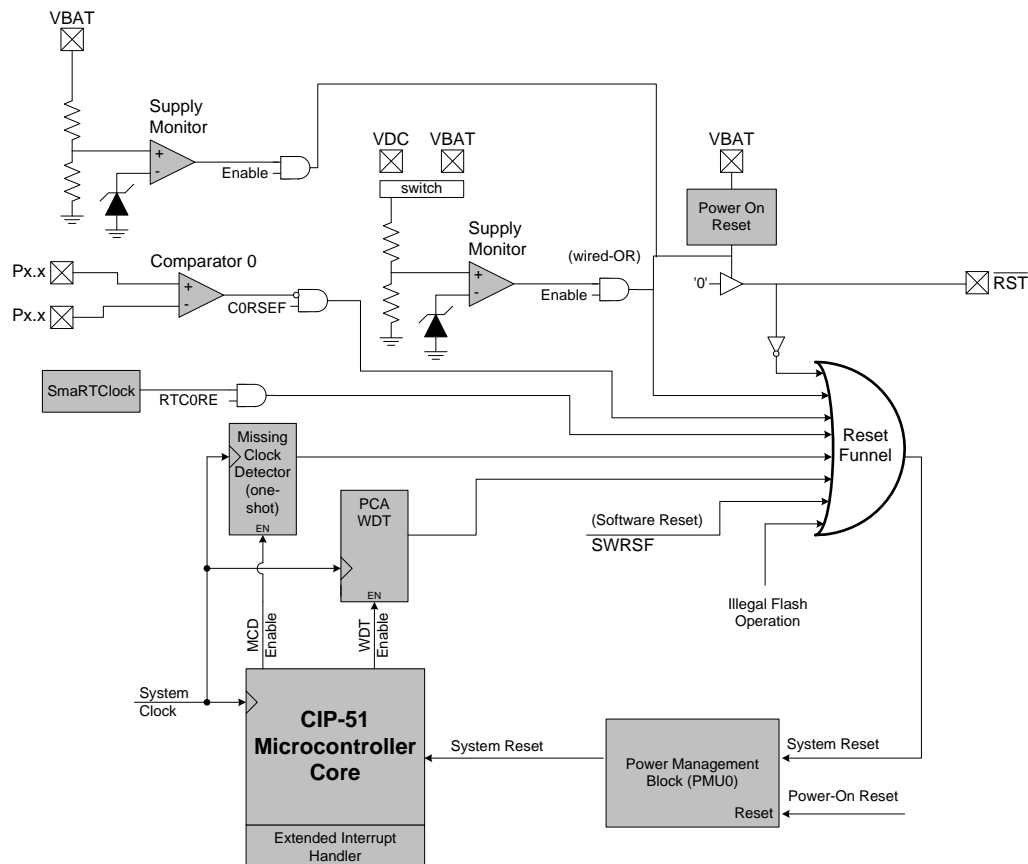

Figure 22.1. Reset Sources

22.1. Power-On Reset

During power-up, the device is held in a reset state and the $\overline{\text{RST}}$ pin voltage tracks the supply voltage (through a weak pull-up) until the device is released from reset. After the supply settles above V_{POR} , a delay occurs before the device is released from reset; the delay decreases as the supply ramp time increases (ramp time is defined as how fast the supply ramps from 0 V to V_{POR}). Figure 22.2 plots the power-on and supply monitor reset timing. For valid ramp times (less than 3 ms), the power-on reset delay (T_{PORDelay}) is typically 7 ms ($V_{\text{DD}} = 1.8 \text{ V}$) or 15 ms ($V_{\text{DD}} = 3.6 \text{ V}$).

Note: The maximum supply ramp time is 3 ms; slower ramp times may cause the device to be released from reset before the supply reaches the V_{POR} level.

On exit from a power-on reset, the PORSF flag (RSTSRC.1) is set by hardware to logic 1. When PORSF is set, all of the other reset flags in the RSTSRC Register are indeterminate (PORSF is cleared by all other resets). Since all resets cause program execution to begin at the same location (0x0000), software can read the PORSF flag to determine if a power-up was the cause of reset. The contents of internal data memory should be assumed to be undefined after a power-on reset.

The POR supply monitor will continue to monitor the VBAT supply, even in Sleep Mode, to reset the system if the supply voltage drops below V_{POR} . It can be disabled to save power by writing 1 to the MONDIS (PMU0MD.5) bit. When the POR supply monitor is disabled, all reset sources will trigger a full POR and will re-enable the POR supply monitor.

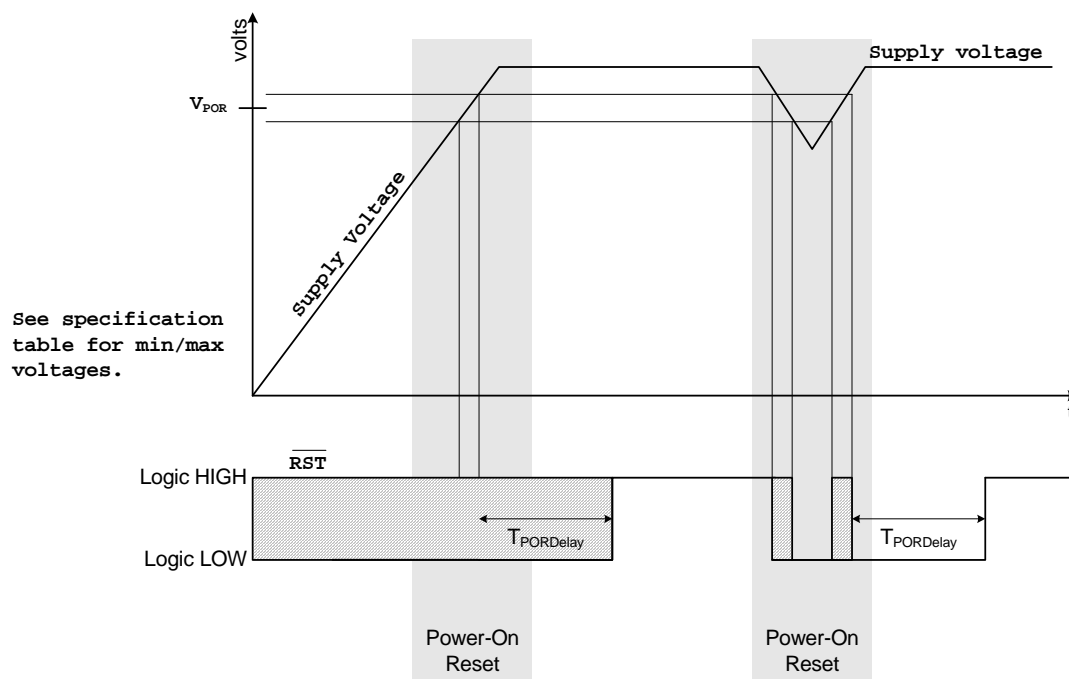

Figure 22.2. Power-On Reset Timing Diagram

22.2. Power-Fail Reset

Si102x/3x devices have two Active Mode Supply Monitors that can hold the system in reset if the supply voltage drops below V_{RST} . The first of the two identical supply monitors is connected to the output of the supply select switch (which chooses the VBAT or VDC pin as the source of the digital supply voltage) and is enabled and selected as a reset source after each power-on or power-fail reset. This supply monitor will be referred to as the digital supply monitor. The second supply monitor is connected directly to the VBAT pin and is disabled after each power-on or power-fail reset. This supply monitor will be referred to as the analog supply monitor. The analog supply monitor should be enabled any time the supply select switch is set to the VDC pin to ensure that the VBAT supply does not drop below V_{RST} .

When enabled and selected as a reset source, any power down transition or power irregularity that causes the monitored supply voltage to drop below V_{RST} will cause the \overline{RST} pin to be driven low and the CIP-51 will be held in a reset state (see Figure 22.2). When the supply voltage returns to a level above V_{RST} , the CIP-51 will be released from the reset state.

After a power-fail reset, the PORSF flag reads 1, the contents of RAM invalid, and the digital supply monitor is enabled and selected as a reset source. The enable state of either supply monitor and its selection as a reset source is only altered by power-on and power-fail resets. For example, if the supply monitor is de-selected as a reset source and disabled by software, then a software reset is performed, the supply monitor will remain disabled and de-selected after the reset.

In battery-operated systems, the contents of RAM can be preserved near the end of the battery's usable life if the device is placed in Sleep Mode prior to a power-fail reset occurring. When the device is in Sleep Mode, the power-fail reset is automatically disabled, both active mode supply monitors are turned off, and the contents of RAM are preserved as long as the supply does not fall below V_{POR} . A large capacitor can be used to hold the power supply voltage above V_{POR} while the user is replacing the battery. Upon waking from Sleep mode, the enable and reset source select state of the V_{DD} supply monitor are restored to the value last set by the user.

To allow software early notification that a power failure is about to occur, the VDDOK bit is cleared when the supply falls below the V_{WARN} threshold. The VDDOK bit can be configured to generate an interrupt. Each of the active mode supply monitors have their independent VDDOK and V_{WARN} flags. See Section "17. Interrupt Handler" on page 238 for more details.

Important Note: To protect the integrity of Flash contents, **the active mode supply monitor(s) must be enabled and selected as a reset source if software contains routines which erase or write Flash memory.** If the digital supply monitor is not enabled, any erase or write performed on Flash memory will cause a Flash Error device reset.

Si102x/3x

Important Notes:

- The Power-on Reset (POR) delay is not incurred after a supply monitor reset. See Section “4. Electrical Characteristics” on page 50 for complete electrical characteristics of the active mode supply monitors.
- Software should take care not to inadvertently disable the supply monitor as a reset source when writing to RSTSRC to enable other reset sources or to trigger a software reset. All writes to RSTSRC should explicitly set PORSF to 1 to keep the supply monitor enabled as a reset source.
- The supply monitor must be enabled before selecting it as a reset source. Selecting the supply monitor as a reset source before it has stabilized may generate a system reset. In systems where this reset would be undesirable, a delay should be introduced between enabling the supply monitor and selecting it as a reset source. See Section “4. Electrical Characteristics” on page 50 for minimum supply monitor turn-on time. **No delay should be introduced in systems where software contains routines that erase or write Flash memory.** The procedure for enabling the V_{DD} supply monitor and selecting it as a reset source is shown below:
 1. Enable the Supply Monitor (VDMEN bit in VDM0CN = 1).
 2. Wait for the Supply Monitor to stabilize (optional).
 3. Select the Supply Monitor as a reset source (PORSF bit in RSTSRC = 1).

SFR Definition 22.1. VDM0CN: VDD Supply Monitor Control

Bit	7	6	5	4	3	2	1	0
Name	VDMEN	VDDSTAT	VDDOK	VDDOKIE	VBMEN	VBSTAT	VBOK	VBOKIE
Type	R/W	R	R	R/W	R/W	R	R	R/W
Reset	1	Varies	Varies	0	0	0	0	0

SFR Page = All Pages; SFR Address = 0xFF

Bit	Name	Function
7	VDMEN	Digital Supply Monitor Enable (Power Select Switch Output). 0: Digital Supply Monitor Disabled. 1: Digital Supply Monitor Enabled.
6	VDDSTAT	Digital Supply Status. This bit indicates the current digital power supply status. 0: Digital supply is at or below the V_{RST} threshold. 1: Digital supply is above the V_{RST} threshold.
5	VDDOK	Digital Supply Status (Early Warning). This bit indicates the current digital power supply status. 0: Digital supply is at or below the VDD_{WARN} threshold. 1: Digital supply is above the VDD_{WARN} threshold.
4	VDDOKIE	Digital Early Warning Interrupt Enable. Enables the V_{DD} Early Warning Interrupt. 0: V_{DD} Early Warning Interrupt is disabled. 1: V_{DD} Early Warning Interrupt is enabled.
3	VBMEN	Analog Supply Monitor Enable (VBAT Pin). 0: Analog Supply Monitor Disabled. 1: Analog Supply Monitor Enabled.
2	VBSTAT	Analog Supply Status. This bit indicates the analog (VBAT) power supply status. 0: VBAT is at or below the V_{RST} threshold. 1: VBAT is above the V_{RST} threshold.
1	VBOK	Analog Supply Status (Early Warning). This bit indicates the current VBAT power supply status. 0: VBAT is at or below the VDD_{WARN} threshold. 1: VBAT is above the VDD_{WARN} threshold.
0	VBOKIE	Analog Early Warning Interrupt Enable. Enables the VBAT Early Warning Interrupt. 0: VBAT Early Warning Interrupt is disabled. 1: VBAT Early Warning Interrupt is enabled.

22.3. External Reset

The external $\overline{\text{RST}}$ pin provides a means for external circuitry to force the device into a reset state. Asserting an active-low signal on the $\overline{\text{RST}}$ pin generates a reset; an external pullup and/or decoupling of the $\overline{\text{RST}}$ pin may be necessary to avoid erroneous noise-induced resets. See Table 4.6 for complete $\overline{\text{RST}}$ pin specifications. The external reset remains functional even when the device is in the low power suspend and sleep modes. The PINRSF flag (RSTSRC.0) is set on exit from an external reset.

22.4. Missing Clock Detector Reset

The missing clock detector (MCD) is a one-shot circuit that is triggered by the system clock. If the system clock remains high or low for more than 100 μs , the one-shot will time out and generate a reset. After a MCD reset, the MCDRSF flag (RSTSRC.2) will read 1, signifying the MCD as the reset source; otherwise, this bit reads 0. Writing a 1 to the MCDRSF bit enables the Missing Clock Detector; writing a 0 disables it. The missing clock detector reset is automatically disabled when the device is in the low power suspend or sleep mode. Upon exit from either low power state, the enabled/disabled state of this reset source is restored to its previous value. The state of the $\overline{\text{RST}}$ pin is unaffected by this reset.

22.5. Comparator0 Reset

Comparator0 can be configured as a reset source by writing a 1 to the CORSEF flag (RSTSRC.5). Comparator0 should be enabled and allowed to settle prior to writing to CORSEF to prevent any turn-on chatter on the output from generating an unwanted reset. The Comparator0 reset is active-low: if the non-inverting input voltage (on CP0+) is less than the inverting input voltage (on CP0-), the device is put into the reset state. After a Comparator0 reset, the CORSEF flag (RSTSRC.5) will read 1 signifying Comparator0 as the reset source; otherwise, this bit reads 0. The Comparator0 reset source remains functional even when the device is in the low power suspend and sleep states as long as Comparator0 is also enabled as a wake-up source. The state of the $\overline{\text{RST}}$ pin is unaffected by this reset.

22.6. PCA Watchdog Timer Reset

The programmable watchdog timer (WDT) function of the programmable counter array (PCA) can be used to prevent software from running out of control during a system malfunction. The PCA WDT function can be enabled or disabled by software as described in Section “34.4. Watchdog Timer Mode” on page 524; the WDT is enabled and clocked by SYSCLK / 12 following any reset. If a system malfunction prevents user software from updating the WDT, a reset is generated and the WDTRSF bit (RSTSRC.5) is set to 1. The PCA Watchdog Timer reset source is automatically disabled when the device is in the low power suspend or sleep mode. Upon exit from either low power state, the enabled/disabled state of this reset source is restored to its previous value. The state of the $\overline{\text{RST}}$ pin is unaffected by this reset.

22.7. Flash Error Reset

If a Flash read/write/erase or program read targets an illegal address, a system reset is generated. This may occur due to any of the following:

- A Flash write or erase is attempted above user code space. This occurs when PSWE is set to 1 and a MOVX write operation targets an address above the Lock Byte address.
- A Flash read is attempted above user code space. This occurs when a MOVC operation targets an address above the Lock Byte address.
- A Program read is attempted above user code space. This occurs when user code attempts to branch to an address above the Lock Byte address.
- A Flash read, write or erase attempt is restricted due to a Flash security setting (see Section “18.3. Security Options” on page 253).
- A Flash write or erase is attempted while the V_{DD} Monitor is disabled.

The FERROR bit (RSTSRC.6) is set following a Flash error reset. The state of the \overline{RST} pin is unaffected by this reset.

22.8. SmartClock (Real Time Clock) Reset

The SmartClock can generate a system reset on two events: SmartClock Oscillator Fail or SmartClock Alarm. The SmartClock Oscillator Fail event occurs when the SmartClock Missing Clock Detector is enabled and the SmartClock clock is below approximately 20 kHz. A SmartClock alarm event occurs when the SmartClock Alarm is enabled and the SmartClock timer value matches the ALARMn registers. The SmartClock can be configured as a reset source by writing a 1 to the RTCORE flag (RSTSRC.7). The SmartClock reset remains functional even when the device is in the low power Suspend or Sleep mode. The state of the \overline{RST} pin is unaffected by this reset.

22.9. Software Reset

Software may force a reset by writing a 1 to the SWRSF bit (RSTSRC.4). The SWRSF bit will read 1 following a software forced reset. The state of the \overline{RST} pin is unaffected by this reset.

Si102x/3x

SFR Definition 22.2. RSTSRC: Reset Source

Bit	7	6	5	4	3	2	1	0
Name	RTCORE	FERROR	CORSEF	SWRSF	WDTRSF	MCDRSF	PORSF	PINRSF
Type	R/W	R	R/W	R/W	R	R/W	R/W	R
Reset	Varies	Varies	Varies	Varies	Varies	Varies	Varies	Varies

SFR Page = 0x0; SFR Address = 0xEF.

Bit	Name	Description	Write	Read
7	RTCORE	SmaRTClock Reset Enable and Flag	0: Disable SmaRTClock as a reset source. 1: Enable SmaRTClock as a reset source.	Set to 1 if SmaRTClock alarm or oscillator fail caused the last reset.
6	FERROR	Flash Error Reset Flag.	N/A	Set to 1 if Flash read/write/erase error caused the last reset.
5	CORSEF	Comparator0 Reset Enable and Flag.	0: Disable Comparator0 as a reset source. 1: Enable Comparator0 as a reset source.	Set to 1 if Comparator0 caused the last reset.
4	SWRSF	Software Reset Force and Flag.	Writing a 1 forces a system reset.	Set to 1 if last reset was caused by a write to SWRSF.
3	WDTRSF	Watchdog Timer Reset Flag.	N/A	Set to 1 if Watchdog Timer overflow caused the last reset.
2	MCDRSF	Missing Clock Detector (MCD) Enable and Flag.	0: Disable the MCD. 1: Enable the MCD. The MCD triggers a reset if a missing clock condition is detected.	Set to 1 if Missing Clock Detector timeout caused the last reset.
1	PORSF	Power-On / Power-Fail Reset Flag, and Power-Fail Reset Enable.	0: Disable the VDD Supply Monitor as a reset source. 1: Enable the VDD Supply Monitor as a reset source. ³	Set to 1 anytime a power-on or V _{DD} monitor reset occurs. ²
0	PINRSF	HW Pin Reset Flag.	N/A	Set to 1 if $\overline{\text{RST}}$ pin caused the last reset.

Notes:

1. It is safe to use read-modify-write operations (ORL, ANL, etc.) to enable or disable specific interrupt sources.
2. If PORSF read back 1, the value read from all other bits in this register are indeterminate.
3. Writing a 1 to PORSF before the VDD Supply Monitor is stabilized may generate a system reset.

23. Clocking Sources

Si102x/3x devices include a programmable precision internal oscillator, an external oscillator drive circuit, a low power internal oscillator, and a SmarTClock real time clock oscillator. The precision internal oscillator can be enabled/disabled and calibrated using the OSCICN and OSCICL registers, as shown in Figure 23.1. The external oscillator can be configured using the OSCXCN register. The low power internal oscillator is automatically enabled and disabled when selected and deselected as a clock source. SmarT-Clock operation is described in the SmarT-Clock oscillator chapter.

The system clock (SYSCLK) can be derived from the precision internal oscillator, external oscillator, low power internal oscillator, low power internal oscillator divided by 8, or SmarT-Clock oscillator. The global clock divider can generate a system clock that is 1, 2, 4, 8, 16, 32, 64, or 128 times slower than the selected input clock source. Oscillator electrical specifications can be found in the Electrical Specifications Chapter.

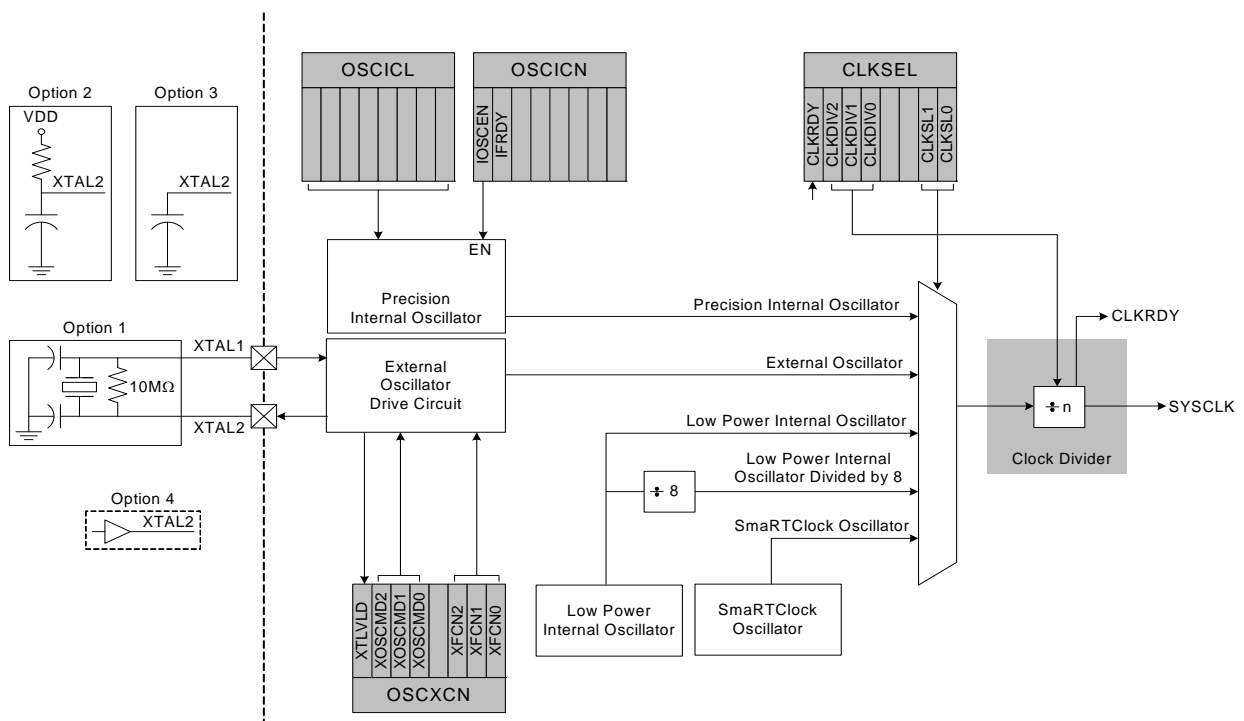

Figure 23.1. Clocking Sources Block Diagram

The proper way of changing the system clock when both the clock source and the clock divide value are being changed is as follows:

If switching from a fast “undivided” clock to a slower “undivided” clock:

1. Change the clock divide value.
2. Poll for CLKRDY > 1.
3. Change the clock source.

If switching from a slow “undivided” clock to a faster “undivided” clock:

1. Change the clock source.
2. Change the clock divide value.
3. Poll for CLKRDY > 1.

Si102x/3x

23.1. Programmable Precision Internal Oscillator

All Si102x/3x devices include a programmable precision internal oscillator that may be selected as the system clock. OSCICL is factory calibrated to obtain a 24.5 MHz frequency. See Section “4. Electrical Characteristics” on page 50 for complete oscillator specifications.

The precision oscillator supports a spread spectrum mode which modulates the output frequency in order to reduce the EMI generated by the system. When enabled (SSE = 1), the oscillator output frequency is modulated by a stepped triangle wave whose frequency is equal to the oscillator frequency divided by 384 (63.8 kHz using the factory calibration). The deviation from the nominal oscillator frequency is +0%, -1.6%, and the step size is typically 0.26% of the nominal frequency. When using this mode, the typical average oscillator frequency is lowered from 24.5 MHz to 24.3 MHz.

23.2. Low Power Internal Oscillator

All Si102x/3x devices include a low power internal oscillator that defaults as the system clock after a system reset. The low power internal oscillator frequency is 20 MHz \pm 10% and is automatically enabled when selected as the system clock and disabled when not in use. See Section “4. Electrical Characteristics” on page 50 for complete oscillator specifications.

23.3. External Oscillator Drive Circuit

All Si102x/3x devices include an external oscillator circuit that may drive an external crystal, ceramic resonator, capacitor, or RC network. A CMOS clock may also provide a clock input. Figure 23.1 shows a block diagram of the four external oscillator options. The external oscillator is enabled and configured using the OSCXCN register.

The external oscillator output may be selected as the system clock or used to clock some of the digital peripherals (e.g., Timers, PCA, etc.). See the data sheet chapters for each digital peripheral for details. See Section “4. Electrical Characteristics” on page 50 for complete oscillator specifications.

23.3.1. External Crystal Mode

If a crystal or ceramic resonator is used as the external oscillator, the crystal/resonator and a 10 M Ω resistor must be wired across the XTAL1 and XTAL2 pins as shown in Figure 23.1, Option 1. Appropriate loading capacitors should be added to XTAL1 and XTAL2, and both pins should be configured for analog I/O with the digital output drivers disabled.

Figure 23.2 shows the external oscillator circuit for a 20 MHz quartz crystal with a manufacturer recommended load capacitance of 12.5 pF. Loading capacitors are "in series" as seen by the crystal and "in parallel" with the stray capacitance of the XTAL1 and XTAL2 pins. The total value of the each loading capacitor and the stray capacitance of each XTAL pin should equal 12.5 pF \times 2 = 25 pF. With a stray capacitance of 10 pF per pin, the 15 pF capacitors yield an equivalent series capacitance of 12.5 pF across the crystal.

Note: The recommended load capacitance depends upon the crystal and the manufacturer. Please refer to the crystal data sheet when completing these calculations.

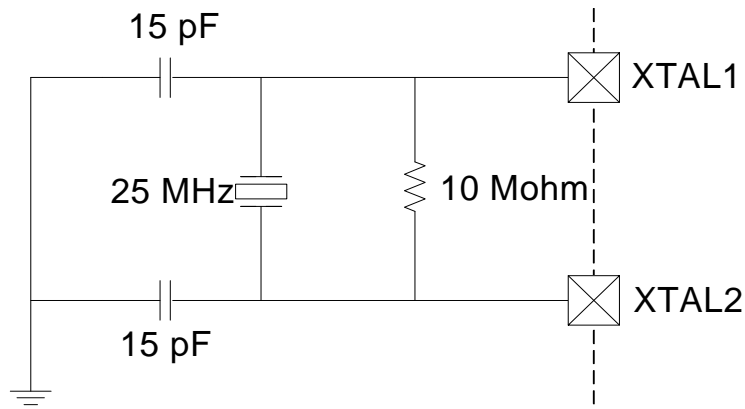

Figure 23.2. 25 MHz External Crystal Example

Important Note on External Crystals: Crystal oscillator circuits are quite sensitive to PCB layout. The crystal should be placed as close as possible to the XTAL pins on the device. The traces should be as short as possible and shielded with ground plane from any other traces which could introduce noise or interference.

When using an external crystal, the external oscillator drive circuit must be configured by software for *Crystal Oscillator Mode* or *Crystal Oscillator Mode with divide by 2 stage*. The divide by 2 stage ensures that the clock derived from the external oscillator has a duty cycle of 50%. The External Oscillator Frequency Control value (XFCN) must also be specified based on the crystal frequency. The selection should be based on Table 23.1. For example, a 25 MHz crystal requires an XFCN setting of 111b.

Table 23.1. Recommended XFCN Settings for Crystal Mode

XFCN	Crystal Frequency	Bias Current	Typical Supply Current (VDD = 2.4 V)
000	$f \leq 20$ kHz	0.5 μ A	3.0 μ A, $f = 32.768$ kHz
001	20 kHz < $f \leq 58$ kHz	1.5 μ A	4.8 μ A, $f = 32.768$ kHz
010	58 kHz < $f \leq 155$ kHz	4.8 μ A	9.6 μ A, $f = 32.768$ kHz
011	155 kHz < $f \leq 415$ kHz	14 μ A	28 μ A, $f = 400$ kHz
100	415 kHz < $f \leq 1.1$ MHz	40 μ A	71 μ A, $f = 400$ kHz
101	1.1 MHz < $f \leq 3.1$ MHz	120 μ A	193 μ A, $f = 400$ kHz
110	3.1 MHz < $f \leq 8.2$ MHz	550 μ A	940 μ A, $f = 8$ MHz
111	8.2 MHz < $f \leq 25$ MHz	2.6 mA	3.9 mA, $f = 25$ MHz

When the crystal oscillator is first enabled, the external oscillator valid detector allows software to determine when the external system clock has stabilized. Switching to the external oscillator before the crystal oscillator has stabilized can result in unpredictable behavior. The recommended procedure for starting the crystal is as follows:

1. Configure XTAL1 and XTAL2 for analog I/O and disable the digital output drivers.
2. Configure and enable the external oscillator.
3. Poll for XTLVLD => 1.
4. Switch the system clock to the external oscillator.

Si102x/3x

23.3.2. External RC Mode

If an RC network is used as the external oscillator, the circuit should be configured as shown in Figure 23.1, Option 2. The RC network should be added to XTAL2, and XTAL2 should be configured for analog I/O with the digital output drivers disabled. XTAL1 is not affected in RC mode.

The capacitor should be no greater than 100 pF; however for very small capacitors, the total capacitance may be dominated by parasitic capacitance in the PCB layout. The resistor should be no smaller than 10 kΩ. The oscillation frequency can be determined by the following equation:

$$f = \frac{1.23 \times 10^3}{R \times C}$$

where

f = frequency of clock in MHz
R = pull-up resistor value in kΩ

V_{DD} = power supply voltage in Volts
C = capacitor value on the XTAL2 pin in pF

To determine the required External Oscillator Frequency Control value (XFCN) in the OSCXCN Register, first select the RC network value to produce the desired frequency of oscillation. For example, if the frequency desired is 100 kHz, let R = 246 kΩ and C = 50 pF:

$$f = \frac{1.23 \times 10^3}{R \times C} = \frac{1.23 \times 10^3}{246 \times 50} = 100 \text{ kHz}$$

where

f = frequency of clock in MHz
R = pull-up resistor value in kΩ

V_{DD} = power supply voltage in Volts
C = capacitor value on the XTAL2 pin in pF

Referencing Table 23.2, the recommended XFCN setting is 010.

Table 23.2. Recommended XFCN Settings for RC and C modes

XFCN	Approximate Frequency Range (RC and C Mode)	K Factor (C Mode)	Typical Supply Current/ Actual Measured Frequency (C Mode, V _{DD} = 2.4 V)
000	f ≤ 25 kHz	K Factor = 0.87	3.0 μA, f = 11 kHz, C = 33 pF
001	25 kHz < f ≤ 50 kHz	K Factor = 2.6	5.5 μA, f = 33 kHz, C = 33 pF
010	50 kHz < f ≤ 100 kHz	K Factor = 7.7	13 μA, f = 98 kHz, C = 33 pF
011	100 kHz < f ≤ 200 kHz	K Factor = 22	32 μA, f = 270 kHz, C = 33 pF
100	200 kHz < f ≤ 400 kHz	K Factor = 65	82 μA, f = 310 kHz, C = 46 pF
101	400 kHz < f ≤ 800 kHz	K Factor = 180	242 μA, f = 890 kHz, C = 46 pF
110	800 kHz < f ≤ 1.6 MHz	K Factor = 664	1.0 mA, f = 2.0 MHz, C = 46 pF
111	1.6 MHz < f ≤ 3.2 MHz	K Factor = 1590	4.6 mA, f = 6.8 MHz, C = 46 pF

When the RC oscillator is first enabled, the external oscillator valid detector allows software to determine when oscillation has stabilized. The recommended procedure for starting the RC oscillator is as follows:

1. Configure XTAL2 for analog I/O and disable the digital output drivers.
2. Configure and enable the external oscillator.
3. Poll for XTLVLD ≥ 1.
4. Switch the system clock to the external oscillator.

23.3.3. External Capacitor Mode

If a capacitor is used as the external oscillator, the circuit should be configured as shown in Figure 23.1, Option 3. The capacitor should be added to XTAL2, and XTAL2 should be configured for analog I/O with the digital output drivers disabled. XTAL1 is not affected in RC mode.

The capacitor should be no greater than 100 pF; however, for very small capacitors, the total capacitance may be dominated by parasitic capacitance in the PCB layout. The oscillation frequency and the required External Oscillator Frequency Control value (XFCN) in the OSCXCN Register can be determined by the following equation:

$$f = \frac{KF}{C \times V_{DD}}$$

where

f = frequency of clock in MHz R = pull-up resistor value in kΩ

V_{DD} = power supply voltage in Volts C = capacitor value on the XTAL2 pin in pF

Below is an example of selecting the capacitor and finding the frequency of oscillation Assume V_{DD} = 3.0 V and f = 150 kHz:

$$f = \frac{KF}{C \times V_{DD}}$$

$$0.150 \text{ MHz} = \frac{KF}{C \times 3.0}$$

Since a frequency of roughly 150 kHz is desired, select the K Factor from Table 23.2 as KF = 22:

$$0.150 \text{ MHz} = \frac{22}{C \times 3.0 \text{ V}}$$

$$C = \frac{22}{0.150 \text{ MHz} \times 3.0 \text{ V}}$$

$$C = 48.8 \text{ pF}$$

Therefore, the XFCN value to use in this example is 011 and C is approximately 50 pF.

The recommended startup procedure for C mode is the same as RC mode.

23.3.4. External CMOS Clock Mode

If an external CMOS clock is used as the external oscillator, the clock should be directly routed into XTAL2. The XTAL2 pin should be configured as a digital input. XTAL1 is not used in external CMOS clock mode.

The external oscillator valid detector will always return zero when the external oscillator is configured to External CMOS Clock mode.

Si102x/3x

23.4. Special Function Registers for Selecting and Configuring the System Clock

The clocking sources on Si102x/3x devices are enabled and configured using the OSCICN, OSCICL, OSCXCN and the SmaRTClock internal registers. See Section “24. SmaRTClock (Real Time Clock)” on page 302 for SmaRTClock register descriptions. The system clock source for the MCU can be selected using the CLKSEL register. To minimize active mode current, the oneshot timer which sets Flash read time should be bypassed when the system clock is greater than 10 MHz. See the FLSCL register description for details.

The clock selected as the system clock can be divided by 1, 2, 4, 8, 16, 32, 64, or 128. When switching between two clock divide values, the transition may take up to 128 cycles of the undivided clock source. The CLKRDY flag can be polled to determine when the new clock divide value has been applied. The clock divider must be set to "divide by 1" when entering Suspend or Sleep Mode.

The system clock source may also be switched on-the-fly. The switchover takes effect after one clock period of the slower oscillator.

SFR Definition 23.1. CLKSEL: Clock Select

Bit	7	6	5	4	3	2	1	0
Name	CLKRDY	CLKDIV[2:0]				CLKSEL[2:0]		
Type	R	R/W			R/W	R/W		
Reset	0	0	0	1	0	0	1	0

SFR Page = 0x0 and 0xF; SFR Address = 0xA9

Bit	Name	Function
7	CLKRDY	System Clock Divider Clock Ready Flag. 0: The selected clock divide setting has not been applied to the system clock. 1: The selected clock divide setting has been applied to the system clock.
6:4	CLKDIV[2:0]	System Clock Divider Bits. Selects the clock division to be applied to the undivided system clock source. 000: System clock is divided by 1. 001: System clock is divided by 2. 010: System clock is divided by 4. 011: System clock is divided by 8. 100: System clock is divided by 16. 101: System clock is divided by 32. 110: System clock is divided by 64. 111: System clock is divided by 128.
3	Unused	Read = 0b. Must Write 0b.
2:0	CLKSEL[2:0]	System Clock Select. Selects the oscillator to be used as the undivided system clock source. 000: Precision Internal Oscillator. 001: External Oscillator. 010: Low Power Oscillator divided by 8. 011: SmaRTClock Oscillator. 100: Low Power Oscillator. All other values reserved.

SFR Definition 23.2. OSCICN: Internal Oscillator Control

Bit	7	6	5	4	3	2	1	0
Name	IOSCEN	IFRDY						
Type	R/W	R	R/W	R/W	R/W	R/W	R/W	R/W
Reset	0	0	Varies	Varies	Varies	Varies	Varies	Varies

SFR Page = 0x0; SFR Address = 0xB2

Bit	Name	Function
7	IOSCEN	Internal Oscillator Enable. 0: Internal oscillator disabled. 1: Internal oscillator enabled.
6	IFRDY	Internal Oscillator Frequency Ready Flag. 0: Internal oscillator is not running at its programmed frequency. 1: Internal oscillator is running at its programmed frequency.
5:0	Reserved	Must perform read-modify-write.

Notes:

1. Read-modify-write operations such as ORL and ANL must be used to set or clear the enable bit of this register.
2. OSCBIAS (REG0CN.4) must be set to 1 before enabling the precision internal oscillator.

Si102x/3x

SFR Definition 23.3. OSCICL: Internal Oscillator Calibration

Bit	7	6	5	4	3	2	1	0
Name	SSE	OSCICL[6:0]						
Type	R/W	R	R/W	R/W	R/W	R/W	R/W	R/W
Reset	0	Varies	Varies	Varies	Varies	Varies	Varies	Varies

SFR Page = 0xF; SFR Address = 0xB3

Bit	Name	Function
7	SSE	Spread Spectrum Enable. 0: Spread Spectrum clock dithering disabled. 1: Spread Spectrum clock dithering enabled.
6:0	OSCICL	Internal Oscillator Calibration. Factory calibrated to obtain a frequency of 24.5 MHz. Incrementing this register decreases the oscillator frequency and decrementing this register increases the oscillator frequency. The step size is approximately 1% of the calibrated frequency. The recommended calibration frequency range is between 16 and 24.5 MHz.
<p>Note: If the Precision Internal Oscillator is selected as the system clock, the following procedure should be used when changing the value of the internal oscillator calibration bits.</p> <ol style="list-style-type: none"> 1. Switch to a different clock source. 2. Disable the oscillator by writing OSCICN.7 to 0. 3. Change OSCICL to the desired setting. 4. Enable the oscillator by writing OSCICN.7 to 1. 		

SFR Definition 23.4. OSCXCN: External Oscillator Control

Bit	7	6	5	4	3	2	1	0
Name	XCLKVLD	XOSCMD[2:0]				XFCN[2:0]		
Type	R	R	R/W	R/W	R/W	R/W	R/W	R/W
Reset	0	0	0	0	0	0	0	0

SFR Page = 0x0; SFR Address = 0xB1

Bit	Name	Function
7	XCLKVLD	External Oscillator Valid Flag. Provides External Oscillator status and is valid at all times for all modes of operation except External CMOS Clock Mode and External CMOS Clock Mode with divide by 2. In these modes, XCLKVLD always returns 0. 0: External Oscillator is unused or not yet stable. 1: External Oscillator is running and stable.
6:4	XOSCMD	External Oscillator Mode Bits. Configures the external oscillator circuit to the selected mode. 00x: External Oscillator circuit disabled. 010: External CMOS Clock Mode. 011: External CMOS Clock Mode with divide by 2 stage. 100: RC Oscillator Mode. 101: Capacitor Oscillator Mode. 110: Crystal Oscillator Mode. 111: Crystal Oscillator Mode with divide by 2 stage.
3	Reserved	Read = 0b. Must Write 0b.
2:0	XFCN	External Oscillator Frequency Control Bits. Controls the external oscillator bias current. 000-111: See Table 23.1 on page 295 (Crystal Mode) or Table 23.2 on page 296 (RC or C Mode) for recommended settings.

24. SmaRTClock (Real Time Clock)

Si102x/3x devices include an ultra low power 32-bit SmaRTClock Peripheral (Real Time Clock) with alarm. The SmaRTClock has a dedicated 32 kHz oscillator that can be configured for use with or without a crystal. No external resistor or loading capacitors are required. The on-chip loading capacitors are programmable to 16 discrete levels allowing compatibility with a wide range of crystals. The SmaRTClock can operate directly from a 1.8–3.6 V battery voltage and remains operational even when the device goes into its lowest power down mode. The SmaRTClock output can be buffered and routed to a GPIO pin to provide an accurate, low frequency clock to other devices while the MCU is in its lowest power down mode (see “PMU0MD: Power Management Unit Mode” on page 274 for more details). Si102x/3x devices also support an ultra low power internal LFO that reduces sleep mode current.

The SmaRTClock allows a maximum of 36 hour 32-bit independent time-keeping when used with a 32.768 kHz Watch Crystal. The SmaRTClock provides an Alarm and Missing SmaRTClock events, which could be used as reset or wakeup sources. See Section “22. Reset Sources” on page 285 and Section “19. Power Management” on page 264 for details on reset sources and low power mode wake-up sources, respectively.

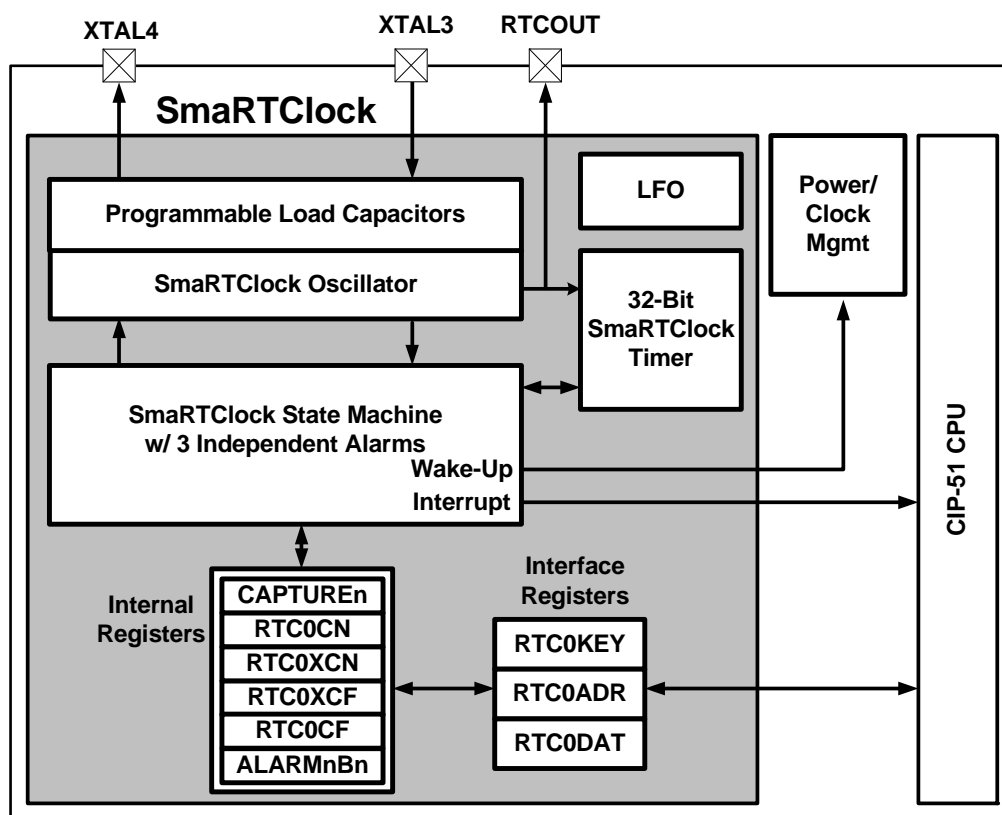

Figure 24.1. SmaRTClock Block Diagram

24.1. SmaRTClock Interface

The SmaRTClock Interface consists of three registers: RTC0KEY, RTC0ADR, and RTC0DAT. These interface registers are located on the CIP-51's SFR map and provide access to the SmaRTClock internal registers listed in Table 24.1. The SmaRTClock internal registers can only be accessed indirectly through the SmaRTClock Interface.

Table 24.1. SmaRTClock Internal Registers

SmaRTClock Address	SmaRTClock Register	Register Name	Description
0x00–0x03	CAPTUREn	SmaRTClock Capture Registers	Four Registers used for setting the 32-bit SmaRTClock timer or reading its current value.
0x04	RTC0CN	SmaRTClock Control Register	Controls the operation of the SmaRTClock State Machine.
0x05	RTC0XCN	SmaRTClock Oscillator Control Register	Controls the operation of the SmaRTClock Oscillator.
0x06	RTC0XCF	SmaRTClock Oscillator Configuration Register	Controls the value of the programmable oscillator load capacitance and enables/disables AutoStep.
0x07	RTC0CF	SmaRTClock Configuration Register	Contains an alarm enable and flag for each SmaRTClock alarm.
0x08–0x0B	ALARM0Bn	SmaRTClock Alarm Registers	Four registers used for setting or reading the 32-bit SmaRTClock alarm value.
0x0C–0x0F	ALARM1Bn	SmaRTClock Alarm Registers	Four registers used for setting or reading the 32-bit SmaRTClock alarm value.
0x10–0x13	ALARM2Bn	SmaRTClock Alarm Registers	Four registers used for setting or reading the 32-bit SmaRTClock alarm value.

24.1.1. SmartClock Lock and Key Functions

The SmartClock Interface has an RTC0KEY register for legacy reasons, however, all writes to this register are ignored. The SmartClock interface is always unlocked on Si102x/3x.

24.1.2. Using RTC0ADR and RTC0DAT to Access SmartClock Internal Registers

The SmartClock internal registers can be read and written using RTC0ADR and RTC0DAT. The RTC0ADR register selects the SmartClock internal register that will be targeted by subsequent reads or writes. A SmartClock Write operation is initiated by writing to the RTC0DAT register. Below is an example of writing to a SmartClock internal register.

1. Write 0x05 to RTC0ADR. This selects the internal RTC0CN register at SmartClock Address 0x05.
2. Write 0x00 to RTC0DAT. This operation writes 0x00 to the internal RTC0CN register.

A SmartClock Read operation is initiated by writing the register address to RTC0ADR and reading from RTC0DAT. Below is an example of reading a SmartClock internal register.

1. Write 0x05 to RTC0ADR. This selects the internal RTC0CN register at SmartClock Address 0x05.
2. Read data from RTC0DAT. This data is a copy of the RTC0CN register.

24.1.3. SmartClock Interface Autoread Feature

When Autoread is enabled, each read from RTC0DAT initiates the next indirect read operation on the SmartClock internal register selected by RTC0ADR. Software should set the register address once at the beginning of each series of consecutive reads. Autoread is enabled by setting AUTORD (RTC0ADR.6) to logic 1.

24.1.4. RTC0ADR Autoincrement Feature

For ease of reading and writing the 32-bit CAPTURE and ALARM values, RTC0ADR automatically increments after each read or write to a CAPTUREn or ALARMn register. This speeds up the process of setting an alarm or reading the current SmartClock timer value. Autoincrement is always enabled.

Recommended Instruction Timing for a multi-byte register read with auto read enabled:

```
mov RTC0ADR, #040h
mov A, RTC0DAT
mov A, RTC0DAT
mov A, RTC0DAT
mov A, RTC0DAT
```

Recommended Instruction Timing for a multi-byte register write:

```
mov RTC0ADR, #010h
mov RTC0DAT, #05h
mov RTC0DAT, #06h
mov RTC0DAT, #07h
mov RTC0DAT, #08h
```

SFR Definition 24.1. RTC0KEY: SmartClock Lock and Key

Bit	7	6	5	4	3	2	1	0
Name	RTC0ST[7:0]							
Type	R/W							
Reset	0	0	0	0	0	0	0	0

SFR Page = 0x0; SFR Address = 0xAE

Bit	Name	Function
7:0	RTC0ST	<p>SmartClock Interface Status. Provides lock status when read.</p> <p>Read: 0x02: SmartClock Interface is unlocked.</p> <p>Write: Writes to RTC0KEY have no effect.</p>

SFR Definition 24.2. RTC0ADR: SmartClock Address

Bit	7	6	5	4	3	2	1	0
Name		AUTORD		ADDR[4:0]				
Type	R	R/W	R	R/W				
Reset	0	0	0	0	0	0	0	0

SFR Page = 0x0; SFR Address = 0xAC

Bit	Name	Function
7	Reserved	Read = 0; Write = don't care.
6	AUTORD	<p>SmartClock Interface Autoread Enable. Enables/disables Autoread. 0: Autoread Disabled. 1: Autoread Enabled.</p>
5	Unused	Read = 0b; Write = Don't Care.
4:0	ADDR[4:0]	<p>SmartClock Indirect Register Address. Sets the currently selected SmartClock register. See Table 24.1 for a listing of all SmartClock indirect registers.</p>

Note: The ADDR bits increment after each indirect read/write operation that targets a CAPTUREn or ALARMnBn internal SmartClock register.

Si102x/3x

SFR Definition 24.3. RTC0DAT: SmartClock Data

Bit	7	6	5	4	3	2	1	0
Name	RTC0DAT[7:0]							
Type	R/W							
Reset	0	0	0	0	0	0	0	0

SFR Page= 0x0; SFR Address = 0xAD

Bit	Name	Function
7:0	RTC0DAT	SmartClock Data Bits. Holds data transferred to/from the internal SmartClock register selected by RTC0ADR.

Note: Read-modify-write instructions (orl, anl, etc.) should not be used on this register.

24.2. SmartClock Clocking Sources

The SmartClock peripheral is clocked from its own timebase, independent of the system clock. The SmartClock timebase can be derived from an external CMOS clock, the internal LFO, or the SmartClock oscillator circuit, which has two modes of operation: Crystal Mode, and Self-Oscillate Mode. The oscillation frequency is 32.768 kHz in Crystal Mode and can be programmed in the range of 10 kHz to 40 kHz in Self-Oscillate Mode. The internal LFO frequency is 16.4 kHz \pm 20%. The frequency of the SmartClock oscillator can be measured with respect to another oscillator using an on-chip timer. See Section “33. Timers” on page 491 for more information on how this can be accomplished.

Note: The SmartClock timebase can be selected as the system clock and routed to a port pin. See Section “23. Clocking Sources” on page 293 for information on selecting the system clock source and Section “27. Port Input/Output” on page 358 for information on how to route the system clock to a port pin. The SmartClock timebase can also be routed to a port pin while the device is in its ultra low power sleep mode. See the PMU0MD register description for details.

24.2.1. Using the SmartClock Oscillator with a Crystal or External CMOS Clock

When using Crystal Mode, a 32.768 kHz crystal should be connected between XTAL3 and XTAL4. No other external components are required. The following steps show how to start the SmartClock crystal oscillator in software:

1. Configure the XTAL3 and XTAL4 pins for Analog I/O.
2. Set SmartClock to Crystal Mode (XMODE = 1).
3. Disable Automatic Gain Control (AGCEN) and enable Bias Doubling (BIASX2) for fast crystal startup.
4. Set the desired loading capacitance (RTC0XCF).
5. Enable power to the SmartClock oscillator circuit (RTC0EN = 1).
6. Wait 20 ms.
7. Poll the SmartClock Clock Valid Bit (CLKVLD) until the crystal oscillator stabilizes.
8. Poll the SmartClock Load Capacitance Ready Bit (LOADRDY) until the load capacitance reaches its programmed value.
9. Enable Automatic Gain Control (AGCEN) and disable Bias Doubling (BIASX2) for maximum power savings.
10. Enable the SmartClock missing clock detector.
11. Wait 2 ms.
12. Clear the PMU0CF wake-up source flags.

In Crystal Mode, the SmartClock oscillator may be driven by an external CMOS clock. The CMOS clock should be applied to XTAL3. XTAL4 should be left floating. In this mode, the external CMOS clock is ac coupled into the SmartClock and should have a minimum voltage swing of 400 mV. The CMOS clock signal voltage should not exceed VDD or drop below GND. Bias levels closer to VDD will result in lower I/O power consumption because the XTAL3 pin has a built-in weak pull-up. The SmartClock oscillator should be configured to its lowest bias setting with AGC disabled. The CLKVLD bit is indeterminate when using a CMOS clock, however, the OSCFAIL bit may be checked 2 ms after SmartClock oscillator is powered on to ensure that there is a valid clock on XTAL3. The CLKVLD bit is forced low when BIASX2 is disabled.

24.2.2. Using the SmarTclock Oscillator in Self-Oscillate Mode

When using Self-Oscillate Mode, the XTAL3 and XTAL4 pins are internally shorted together. The following steps show how to configure SmarTclock for use in Self-Oscillate Mode:

1. Configure the XTAL3 and XTAL4 pins for analog I/O and disable the digital driver.
2. Set SmarTclock to Self-Oscillate Mode (XMODE = 0).
3. Set the desired oscillation frequency:
For oscillation at about 20 kHz, set BIASX2 = 0.
For oscillation at about 40 kHz, set BIASX2 = 1.
4. The oscillator starts oscillating instantaneously.
5. Fine tune the oscillation frequency by adjusting the load capacitance (RTC0XCF).

24.2.3. Using the Low Frequency Oscillator (LFO)

The low frequency oscillator provides an ultra low power, on-chip clock source to the SmarTclock. The typical frequency of oscillation is 16.4 kHz \pm 20%. No external components are required to use the LFO and the XTAL3 and XTAL4 pins may be used for general purpose I/O without any effect on the LFO.

The following steps show how to configure SmarTclock for use with the LFO:

1. Enable and select the Low Frequency Oscillator (LFOEN = 1).
2. The LFO starts oscillating instantaneously.

When the LFO is enabled, the SmarTclock oscillator increments bit 1 of the 32-bit timer (instead of bit 0). This effectively multiplies the LFO frequency by 2, making the RTC timebase behave as if a 32.768 kHz crystal is connected at the output.

24.2.4. Programmable Load Capacitance

The programmable load capacitance has 16 values to support crystal oscillators with a wide range of recommended load capacitance. If Automatic Load Capacitance Stepping is enabled, the crystal load capacitors start at the smallest setting to allow a fast startup time, then slowly increase the capacitance until the final programmed value is reached. The final programmed loading capacitor value is specified using the LOADCAP bits in the RTC0XCF register. The LOADCAP setting specifies the amount of on-chip load capacitance and does not include any stray PCB capacitance. Once the final programmed loading capacitor value is reached, the LOADRDY flag will be set by hardware to logic 1.

When using the SmarTclock oscillator in Self-Oscillate mode, the programmable load capacitance can be used to fine tune the oscillation frequency. In most cases, increasing the load capacitor value will result in a decrease in oscillation frequency. Table 24.2 shows the crystal load capacitance for various settings of LOADCAP.

Table 24.2. SmarTClock Load Capacitance Settings

LOADCAP	Crystal Load Capacitance	Equivalent Capacitance seen on XTAL3 and XTAL4
0000	4.0 pF	8.0 pF
0001	4.5 pF	9.0 pF
0010	5.0 pF	10.0 pF
0011	5.5 pF	11.0 pF
0100	6.0 pF	12.0 pF
0101	6.5 pF	13.0 pF
0110	7.0 pF	14.0 pF
0111	7.5 pF	15.0 pF
1000	8.0 pF	16.0 pF
1001	8.5 pF	17.0 pF
1010	9.0 pF	18.0 pF
1011	9.5 pF	19.0 pF
1100	10.5 pF	21.0 pF
1101	11.5 pF	23.0 pF
1110	12.5 pF	25.0 pF
1111	13.5 pF	27.0 pF

24.2.5. Automatic Gain Control (Crystal Mode Only) and SmarTClock Bias Doubling

Automatic Gain Control allows the SmarTClock oscillator to trim the oscillation amplitude of a crystal in order to achieve the lowest possible power consumption. Automatic Gain Control automatically detects when the oscillation amplitude has reached a point where it safe to reduce the drive current, therefore, it may be enabled during crystal startup. It is recommended to enable Automatic Gain Control in most systems which use the SmarTClock oscillator in Crystal Mode. The following are recommended crystal specifications and operating conditions when Automatic Gain Control is enabled:

- ESR < 50 kΩ
- Load Capacitance < 10 pF
- Supply Voltage < 3.0 V
- Temperature > -20 °C

When using Automatic Gain Control, it is recommended to perform an oscillation robustness test to ensure that the chosen crystal will oscillate under the worst case condition to which the system will be exposed. The worst case condition that should result in the least robust oscillation is at the following system conditions: lowest temperature, highest supply voltage, highest ESR, highest load capacitance, and lowest bias current (AGC enabled, Bias Double Disabled).

To perform the oscillation robustness test, the SmarTClock oscillator should be enabled and selected as the system clock source. Next, the SYCLK signal should be routed to a port pin configured as a push-pull digital output. The positive duty cycle of the output clock can be used as an indicator of oscillation robust-

Si102x/3x

ness. As shown in Figure 24.2, duty cycles less than TBD% indicate a robust oscillation. As the duty cycle approaches TBD%, oscillation becomes less reliable and the risk of clock failure increases. Increasing the bias current (by disabling AGC) will always improve oscillation robustness and will reduce the output clock's duty cycle. This test should be performed at the worst case system conditions, as results at very low temperatures or high supply voltage will vary from results taken at room temperature or low supply voltage.

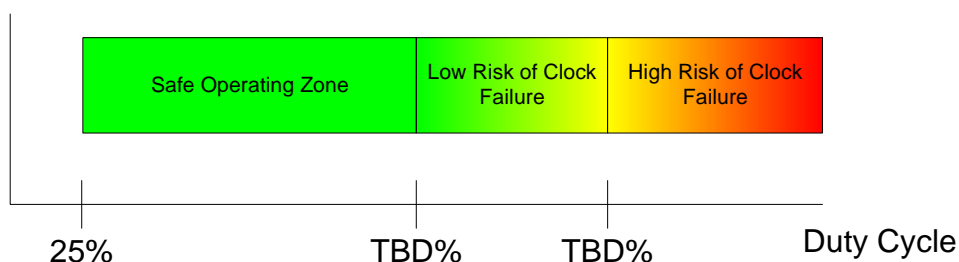

Figure 24.2. Interpreting Oscillation Robustness (Duty Cycle) Test Results

As an alternative to performing the oscillation robustness test, Automatic Gain Control may be disabled at the cost of increased power consumption (approximately 200 nA). Disabling Automatic Gain Control will provide the crystal oscillator with higher immunity against external factors which may lead to clock failure. Automatic Gain Control must be disabled if using the SmarTclock oscillator in self-oscillate mode.

Table 24.3 shows a summary of the oscillator bias settings. The SmarTclock Bias Doubling feature allows the self-oscillation frequency to be increased (almost doubled) and allows a higher crystal drive strength in crystal mode. High crystal drive strength is recommended when the crystal is exposed to poor environmental conditions such as excessive moisture. SmarTclock Bias Doubling is enabled by setting BIASX2 (RTC0XCN.5) to 1.

Table 24.3. SmarTclock Bias Settings

Mode	Setting	Power Consumption
Crystal	Bias Double Off, AGC On	Lowest
	Bias Double Off, AGC Off	Low
	Bias Double On, AGC On	High
	Bias Double On, AGC Off	Highest
Self-Oscillate	Bias Double Off	Low
	Bias Double On	High

24.2.6. Missing SmarTclock Detector

The missing SmarTclock detector is a one-shot circuit enabled by setting MCLKEN (RTC0CN.6) to 1. When the SmarTclock Missing Clock Detector is enabled, OSCFAIL (RTC0CN.5) is set by hardware if SmarTclock oscillator remains high or low for more than 100 μ s.

A SmarTclock Missing Clock detector timeout can trigger an interrupt, wake the device from a low power mode, or reset the device. See Section “17. Interrupt Handler” on page 238, Section “19. Power Management” on page 264, and Section “22. Reset Sources” on page 285 for more information.

Note: The SmarTclock Missing Clock Detector should be disabled when making changes to the oscillator settings in RTC0XCN.

24.2.7. SmarTclock Oscillator Crystal Valid Detector

The SmarTclock oscillator crystal valid detector is an oscillation amplitude detector circuit used during crystal startup to determine when oscillation has started and is nearly stable. The output of this detector can be read from the CLKVLD bit (RTX0XCN.4).

Notes:

1. The CLKVLD bit has a blanking interval of 2 ms. During the first 2 ms after turning on the crystal oscillator, the output of CLKVLD is not valid.
2. This SmarTclock crystal valid detector (CLKVLD) is not intended for detecting an oscillator failure. The missing SmarTclock detector (CLKFAIL) should be used for this purpose.
3. The CLKVLD bit output is driven low when BIASX2 is disabled.

24.3. SmarTclock Timer and Alarm Function

The SmarTclock timer is a 32-bit counter that, when running (RTC0TR = 1), is incremented every SmarTclock oscillator cycle. The timer has an alarm function that can be set to generate an interrupt, wake the device from a low power mode, or reset the device at a specific time. See Section “17. Interrupt Handler” on page 238, Section “19. Power Management” on page 264, and Section “22. Reset Sources” on page 285 for more information.

The SmarTclock timer includes an Auto Reset feature, which automatically resets the timer to zero one SmarTclock cycle after the alarm 0 signal is deasserted. When using Auto Reset, the Alarm match value should always be set to 2 counts less than the desired match value. When using the LFO in combination with Auto Reset, the right-justified Alarm match value should be set to 4 counts less than the desired match value. Auto Reset can be enabled by writing a 1 to ALRM (RTC0CN.2).

24.3.1. Setting and Reading the SmarTclock Timer Value

The 32-bit SmarTclock timer can be set or read using the six CAPTUREn internal registers. Note that the timer does not need to be stopped before reading or setting its value. The following steps can be used to set the timer value:

1. Write the desired 32-bit set value to the CAPTUREn registers.
2. Write 1 to RTC0SET. This will transfer the contents of the CAPTUREn registers to the SmarTclock timer.
3. Operation is complete when RTC0SET is cleared to 0 by hardware.

The following steps can be used to read the current timer value:

1. Write 1 to RTC0CAP. This will transfer the contents of the timer to the CAPTUREn registers.
2. Poll RTC0CAP until it is cleared to 0 by hardware.
3. A snapshot of the timer value can be read from the CAPTUREn registers

Notes:

1. If the system clock is faster than 4x the SmarTclock, then the HSMODE bit should be set to allow the set and capture operations to be concluded quickly (system clock used for transfers).
2. If the system clock is slower than 4x the SmarTclock, then HSMODE should be set to zero, and RTC must be

running (RTC0TR = 1) in order to set or capture the main timer. The transfer can take up to 2 smaRTClock cycles to complete.

24.3.2. Setting a SmaRTClock Alarm

The SmaRTClock alarm function compares the 32-bit value of SmaRTClock Timer to the value of the ALARMnBn registers. An alarm event is triggered if the SmaRTClock timer is **equal to** the ALARMnBn registers. If Auto Reset is enabled, the 32-bit timer will be cleared to zero one SmaRTClock cycle after the alarm 0 event.

The SmaRTClock alarm event can be configured to reset the MCU, wake it up from a low power mode, or generate an interrupt. See Section “17. Interrupt Handler” on page 238, Section “19. Power Management” on page 264, and Section “22. Reset Sources” on page 285 for more information.

The following steps can be used to set up a SmaRTClock Alarm:

1. Disable SmaRTClock Alarm Events (RTC0AEN = 0).
2. Set the ALARMn registers to the desired value.
3. Enable SmaRTClock Alarm Events (RTC0AEN = 1).

Notes:

1. The ALRM bit, which is used as the SmaRTClock Alarm Event flag, is cleared by disabling SmaRTClock Alarm Events (RTC0AEN = 0).
2. If AutoReset is disabled, disabling (RTC0AEN = 0) then Re-enabling Alarm Events (RTC0AEN = 1) after a SmaRTClock Alarm without modifying ALARMn registers will automatically schedule the next alarm after 2^{32} SmaRTClock cycles (approximately 36 hours using a 32.768 kHz crystal).

24.3.3. Software Considerations for using the SmaRTClock Timer and Alarm

The SmaRTClock timer and alarm have two operating modes to suit varying applications. The two modes are described below:

Mode 1:

The first mode uses the SmaRTClock timer as a perpetual timebase which is never reset to zero. Every 36 hours, the timer is allowed to overflow without being stopped or disrupted. The alarm interval is software managed and is added to the ALRMnBn registers by software after each alarm. This allows the alarm match value to always stay ahead of the timer by one software managed interval. If software uses 32-bit unsigned addition to increment the alarm match value, then it does not need to handle overflows since both the timer and the alarm match value will overflow in the same manner.

This mode is ideal for applications which have a long alarm interval (e.g., 24 or 36 hours) and/or have a need for a perpetual timebase. An example of an application that needs a perpetual timebase is one whose wake-up interval is constantly changing. For these applications, software can keep track of the number of timer overflows in a 16-bit variable, extending the 32-bit (36 hour) timer to a 48-bit (272 year) perpetual timebase.

Mode 2:

The second mode uses the SmaRTClock timer as a general purpose up counter which is auto reset to zero by hardware after each alarm 0 event. The alarm interval is managed by hardware and stored in the ALRM0Bn registers. Software only needs to set the alarm interval once during device initialization. After each alarm 0 event, software should keep a count of the number of alarms that have occurred in order to keep track of time. Alarm 1 and alarm 2 events do not trigger the auto reset.

This mode is ideal for applications that require minimal software intervention and/or have a fixed alarm interval. This mode is the most power efficient since it requires less CPU time per alarm.

Internal Register Definition 24.4. RTC0CN: SmaRTClock Control

Bit	7	6	5	4	3	2	1	0
Name	RTC0EN	MCLKEN	OSCFAIL	RTC0TR		HSMODE	RTC0SET	RTC0CAP
Type	R/W	R/W	R/W	R/W	R/W	R/W	R/W	R/W
Reset	0	0	Varies	0	0	0	0	0

SmaRTClock Address = 0x04

Bit	Name	Function
7	RTC0EN	SmaRTClock Enable. Enables/disables the SmaRTClock oscillator and associated bias currents. 0: SmaRTClock oscillator disabled. 1: SmaRTClock oscillator enabled.
6	MCLKEN	Missing SmaRTClock Detector Enable. Enables/disables the missing SmaRTClock detector. 0: Missing SmaRTClock detector disabled. 1: Missing SmaRTClock detector enabled.
5	OSCFAIL	SmaRTClock Oscillator Fail Event Flag. Set by hardware when a missing SmaRTClock detector timeout occurs. Must be cleared by software. The value of this bit is not defined when the SmaRTClock oscillator is disabled.
4	RTC0TR	SmaRTClock Timer Run Control. Controls if the SmaRTClock timer is running or stopped (holds current value). 0: SmaRTClock timer is stopped. 1: SmaRTClock timer is running.
3	Reserved	Read = 0b; Must write 0b.
2	HSMODE	High Speed Mode Enable. Should be set to 1 if the system clock is faster than 4x the SmaRTClock frequency. 0: High Speed Mode is disabled. 1: High Speed Mode is enabled.
1	RTC0SET	SmaRTClock Timer Set. Writing 1 initiates a SmaRTClock timer set operation. This bit is cleared to 0 by hardware to indicate that the timer set operation is complete.
0	RTC0CAP	SmaRTClock Timer Capture. Writing 1 initiates a SmaRTClock timer capture operation. This bit is cleared to 0 by hardware to indicate that the timer capture operation is complete.

Si102x/3x

Internal Register Definition 24.5. RTC0XCN: SmaRTClock Oscillator Control

Bit	7	6	5	4	3	2	1	0
Name	AGCEN	XMODE	BIASX2	CLKVLD	LFOEN			
Type	R/W	R/W	R/W	R	R/W	R	R	R
Reset	0	0	0	0	0	0	0	0

SmaRTClock Address = 0x05

Bit	Name	Function
7	AGCEN	SmaRTClock Oscillator Automatic Gain Control (AGC) Enable. 0: AGC disabled. 1: AGC enabled.
6	XMODE	SmaRTClock Oscillator Mode. Selects Crystal or Self Oscillate Mode. 0: Self-Oscillate Mode selected. 1: Crystal Mode selected.
5	BIASX2	SmaRTClock Oscillator Bias Double Enable. Enables/disables the Bias Double feature. 0: Bias Double disabled. 1: Bias Double enabled.
4	CLKVLD	SmaRTClock Oscillator Crystal Valid Indicator. Indicates if oscillation amplitude is sufficient for maintaining oscillation. This bit always reads 0 when BIASX2 is disabled. 0: Oscillation has not started or oscillation amplitude is too low to maintain oscillation. 1: Sufficient oscillation amplitude detected.
3	LFOEN	Low Frequency Oscillator Enable and Select. Overrides XMODE and selects the internal low frequency oscillator (LFO) as the SmaRTClock oscillator source. 0: XMODE determines SmaRTClock oscillator source. 1: LFO enabled and selected as SmaRTClock oscillator source.
2:0	Unused	Read = 000b; Write = Don't Care.

Internal Register Definition 24.6. RTC0XCF: SmaRTClock Oscillator Configuration

Bit	7	6	5	4	3	2	1	0
Name	AUTOSTP	LOADRDY			LOADCAP			
Type	R/W	R	R	R	R/W			
Reset	0	0	0	0	Varies	Varies	Varies	Varies

SmaRTClock Address = 0x06

Bit	Name	Function
7	AUTOSTP	Automatic Load Capacitance Stepping Enable. Enables/disables automatic load capacitance stepping. 0: Load capacitance stepping disabled. 1: Load capacitance stepping enabled.
6	LOADRDY	Load Capacitance Ready Indicator. Set by hardware when the load capacitance matches the programmed value. 0: Load capacitance is currently stepping. 1: Load capacitance has reached its programmed value.
5:4	Unused	Read = 00b; Write = Don't Care.
3:0	LOADCAP	Load Capacitance Programmed Value. Holds the user's desired value of the load capacitance. See Table 24.2 on page 309.

Internal Register Definition 24.7. RTC0CF: SmaRTClock Configuration

Bit	7	6	5	4	3	2	1	0
Name		ALRM2	ALRM1	ALRM0	AUTORST	RTC2EN	RTC1EN	RTC0EN
Type	R/W	R/W	R/W	R/W	R/W	R/W	R/W	R/W
Reset	0	0	0	0	0	0	0	0

SmaRTClock Address = 0x07

Bit	Name	Function
7	Reserved	Read = 0b; Must write 0b.
6	ALRM2	Event Flag for Alarm 2. This bit must be cleared by software. Writing a '1' to this bit has no effect. 0: An Alarm 2 event has not occurred since the last time the flag was cleared. 1: An Alarm 2 event has occurred.
5	ALRM1	Event Flag for Alarm 1. This bit must be cleared by software. Writing a '1' to this bit has no effect. 0: An Alarm 1 event has not occurred since the last time the flag was cleared. 1: An Alarm 1 event has occurred.
4	ALRM0	Event Flag for Alarm 0. This bit must be cleared by software. Writing a '1' to this bit has no effect. 0: An Alarm 0 event has not occurred since the last time the flag was cleared. 1: An Alarm 0 event has occurred.
3	AUTORST	Auto Reset Enable. Enables the Auto Reset function to clear the counter when an Alarm 0 event occurs. 0: Auto Reset is disabled 1: Auto Reset is enabled.
2	ALRM2EN	Alarm 2 Enable. 0: Alarm 2 is disabled. 1: Alarm 2 is enabled.
1	ALRM1EN	Alarm 1 Enable. 0: Alarm 1 is disabled. 1: Alarm 1 is enabled.
0	ALRM0EN	Alarm 0 Enable. 0: Alarm 0 is disabled. 1: Alarm 0 is enabled.

Internal Register Definition 24.8. CAPTUREn: SmaRTClock Timer Capture

Bit	7	6	5	4	3	2	1	0
Name	CAPTURE[31:0]							
Type	R/W	R/W	R/W	R/W	R/W	R/W	R/W	R/W
Reset	0	0	0	0	0	0	0	0

SmaRTClock Addresses: CAPTURE0 = 0x00; CAPTURE1 = 0x01; CAPTURE2 = 0x02; CAPTURE3: 0x03.

Bit	Name	Function
7:0	CAPTURE[31:0]	SmaRTClock Timer Capture. These 4 registers (CAPTURE3–CAPTURE0) are used to read or set the 32-bit SmaRTClock timer. Data is transferred to or from the SmaRTClock timer when the RTC0SET or RTC0CAP bits are set.
Note: The least significant bit of the timer capture value is CAPTURE0.0.		

Internal Register Definition 24.9. ALARM0Bn: SmaRTClock Alarm 0 Match Value

Bit	7	6	5	4	3	2	1	0
Name	ALARM0[31:0]							
Type	R/W	R/W	R/W	R/W	R/W	R/W	R/W	R/W
Reset	0	0	0	0	0	0	0	0

SmaRTClock Address: ALARM0B0 = 0x08; ALARM0B1 = 0x09; ALARM0B2 = 0x0A; ALARM0B3 = 0x0B

Bit	Name	Function
7:0	ALARM0[31:0]	SmaRTClock Alarm 0 Programmed Value. These 4 registers (ALARM0B3–ALARM0B0) are used to set an alarm event for the SmaRTClock timer. The SmaRTClock alarm should be disabled (ALRM0EN=0) when updating these registers.
Note: The least significant bit of the alarm programmed value is ALARM0B0.0.		

Si102x/3x

Internal Register Definition 24.10. ALARM1Bn: SmaRTClock Alarm 1 Match Value

Bit	7	6	5	4	3	2	1	0
Name	ALARM1[31:0]							
Type	R/W	R/W	R/W	R/W	R/W	R/W	R/W	R/W
Reset	0	0	0	0	0	0	0	0

SmaRTClock Address: ALARM1B0 = 0x0C; ALARM1B1 = 0x0D; ALARM1B2 = 0x0E; ALARM1B3 = 0x0F

Bit	Name	Function
7:0	ALARM1[31:0]	<p>SmaRTClock Alarm 1 Programmed Value.</p> <p>These 4 registers (ALARM1B3–ALARM1B0) are used to set an alarm event for the SmaRTClock timer. The SmaRTClock alarm should be disabled (ALARM1EN=0) when updating these registers.</p>
<p>Note: The least significant bit of the alarm programmed value is iALARM1B0.0.</p>		

Internal Register Definition 24.11. ALARM2Bn: SmaRTClock Alarm 2 Match Value

Bit	7	6	5	4	3	2	1	0
Name	ALARM2[31:0]							
Type	R/W	R/W	R/W	R/W	R/W	R/W	R/W	R/W
Reset	0	0	0	0	0	0	0	0

SmaRTClock Address: ALARM2B0 = 0x10; ALARM2B1 = 0x11; ALARM2B2 = 0x12; ALARM2B3 = 0x13

Bit	Name	Function
7:0	ALARM2[31:0]	<p>SmaRTClock Alarm 2 Programmed Value.</p> <p>These 4 registers (ALARM2B3–ALARM2B0) are used to set an alarm event for the SmaRTClock timer. The SmaRTClock alarm should be disabled (ALARM2EN=0) when updating these registers.</p>
<p>Note: The least significant bit of the alarm programmed value is ALARM2B0.0.</p>		

25. Low-Power Pulse Counter

The Si102x/3x family of microcontrollers contains a low-power pulse counter module with advanced features, such as ultra low power input comparators with programmable thresholds, a wide range of pull up values with a self calibration engine, asymmetrical integrators for low pass filtering and switch debounce, single, dual, and quadrature modes of operation, two 24-bit counters, and a variety of interrupt and sleep wake-up capabilities. This combination of features provides water, gas, and heat metering system designers with an optimal tool for saving power while collecting meter usage data.

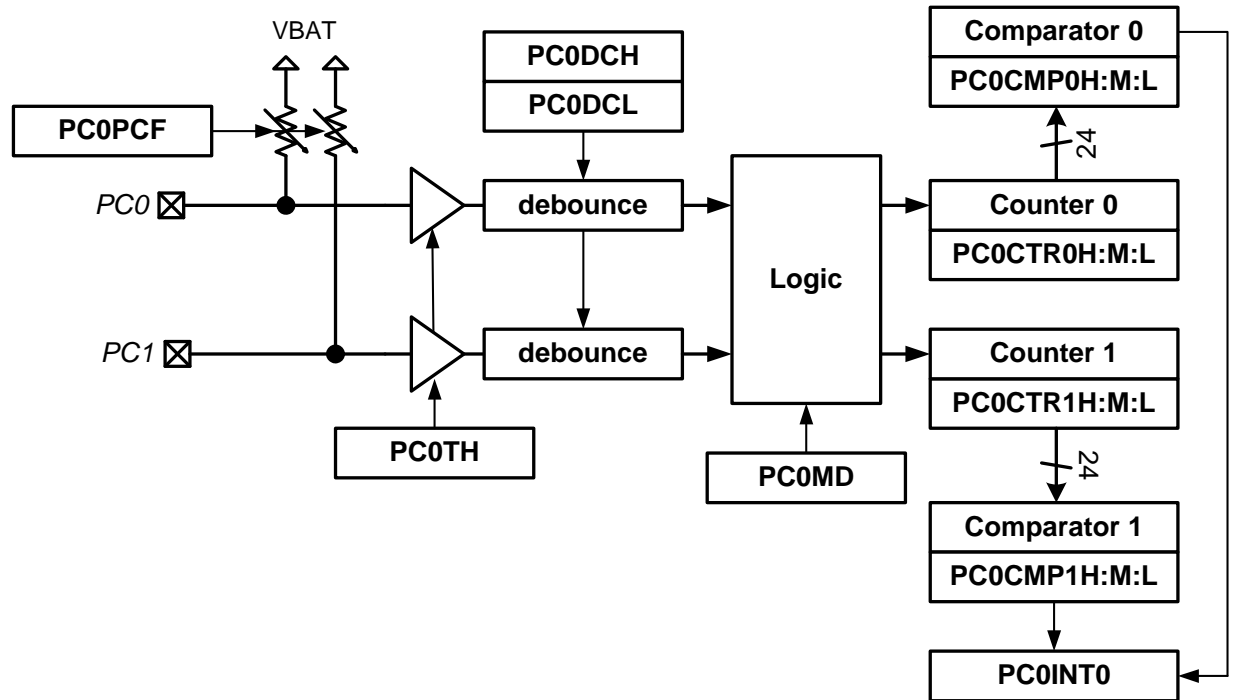

Figure 25.1. Pulse Counter Block Diagram

The low-power pulse counter is a low-power sleep-mode peripheral designed primarily to work meters using reed switches, including water and gas meters. The pulse counter is very flexible and can count pulses from many different types of sources.

The pulse counter operates in sleep mode to enable ultra-low power metering systems. The MCU does not have to wake up on every edge or transition and can remain in sleep mode while the pulse counter counts pulses for an extended period of time. The pulse counter includes two 24-bit counters. These counters can count up to 16,777,215 ($2^{24}-1$) transitions in sleep mode before overflowing. The pulse counter can wake up the MCU when one of the counters overflows. The pulse counter also has two 24-bit digital comparators. The comparators have the ability to wake up the MCU when the one of the counters reaches a predetermined count.

The pulse counter uses the RTC clock for sampling, de-bouncing, and managing the low-power pull-up resistors. The RTC must be enabled when counting pulses. The RTC alarms can wake up the MCU periodically to read the pulse counters instead of using the pulse counter digital comparators. For example, the RTC can wake up the MCU every five minutes. The MCU can then read the pulse counter and transmit the information using the UART or a wireless transceiver.

25.1. Counting Modes

The pulse counter supports three different counting modes: single counter mode, dual counter mode, and quadrature counter mode. Figure 25.2 illustrates the three counter modes.

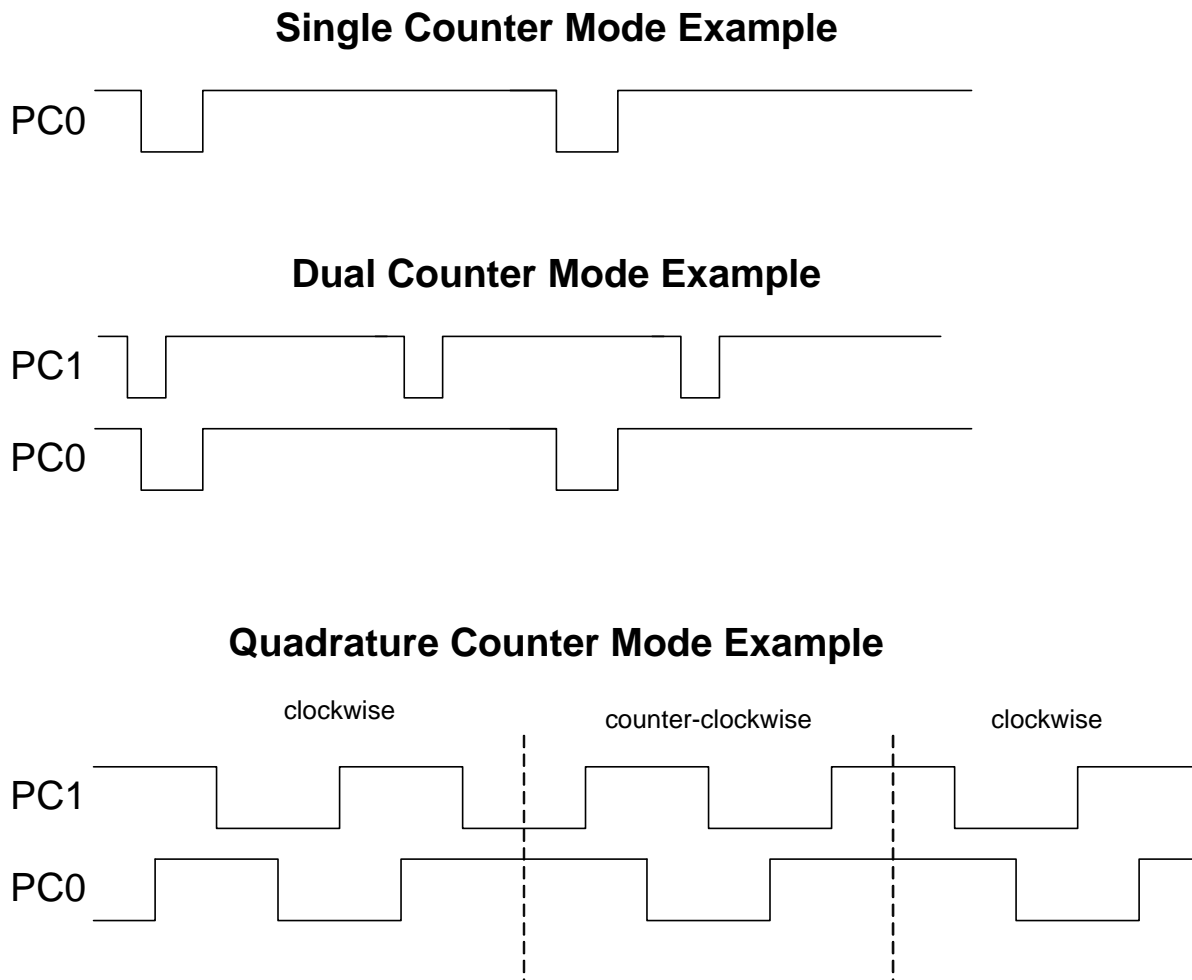

Figure 25.2. Mode Examples

The single counter mode uses only one pulse counter pin PC0 (P1.0) to count pulses from a single input channel. This mode uses only Counter 0 and Comparator 0. (Counter 1 and Comparator 1 are not used.) The single counter mode supports only one meter-encoder with a single-channel output. A single-channel encoder is an effective solution when the metered fluid flows only in one direction. A single-channel encoder does not provide any direction information and does not support bidirectional fluid metering.

The dual counter mode supports two independent single-channel meters. Each meter has its own independent counter and comparator. Some of the global configuration settings apply to both channels, such as pull-up current, sampling rate, and debounce time. The dual mode may also be used for a redundant count using a two-channel non-quadrature encoder.

Quadrature counter mode supports a single two-channel quadrature meter encoder. The quadrature counter mode supports bidirectional encoders and applications with bidirectional fluid flow. In quadrature counter mode, clockwise counts will increment Counter 0, while counterclockwise counts will increment Counter 1. Subtracting Counter 1 from Counter 0 will yield the net position. If the normal fluid flow is clockwise, then

the counterclockwise Counter 1 value represents the cumulative backflow. Firmware may use the backflow counter with the corresponding comparator to implement a backflow alarm. The clockwise sequence is (LL-HL-HH-LH), and the counterclockwise sequence is (LL-LH-HH-HL). (For this sequence LH means PC1 = Low and PC0 = High.)

Firmware cannot write to the counters. The counters are reset when PC0MD is written and have their counting enabled when the PC0MD[7:6] mode bits are set to either single, dual, or quadrature modes. The counters only increment and will roll over to 0x000000 after reaching 0xFFFFFFFF. For single mode, the PC0 input connects to Counter 0. In dual mode, the PC0 input connects to Counter 0 while the PC1 input connects to Counter 1. In Quadrature mode, clockwise counts are sent to Counter 0 while counterclockwise counts are sent to Counter 1.

25.2. Reed Switch Types

The pulse counter works with both Form-A and Form-C reed switches. A Form-A switch is a Normally-Open Single-Pole Single-Throw (NO SPST) switch. A Form-C reed switch is a Single-Pole Double-Throw (SPDT) switch. Figure 25.3 illustrates some of the common reed switch configurations for a single-channel meter.

The Form-A switch requires a pull-up resistor. The energy used by the pull-up resistor may be a substantial portion of the energy budget. To minimize energy usage, the pulse counter has a programmable pull-up resistance and an automatic calibration engine. The calibration engine can automatically determine the smallest usable pull-up strength setting. A Form-C switch does not require a pull-up resistor and will provide a lower power solution. However, the Form-C switches are more expensive and require an additional wire for VBAT.

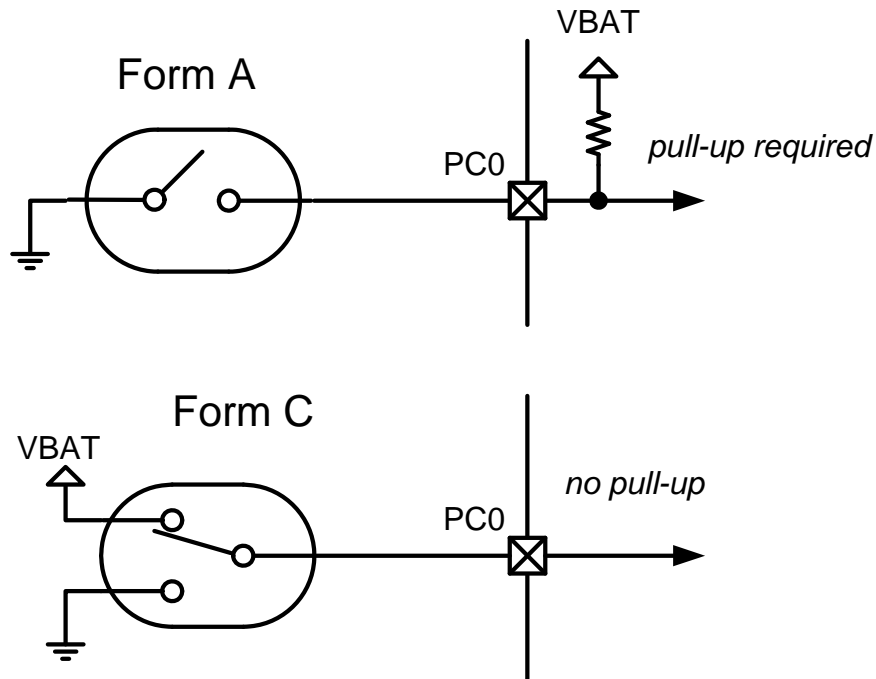

Figure 25.3. Reed Switch Configurations

25.3. Programmable Pull-Up Resistors

The pulse counter features low-power pull-up resistors with a programmable resistance and duty-cycle. The average pull-up current will depend on the selected resistor, sample rate, and pull-up duty-cycle multiplier. Example code is available that will calculate the values for the pull-up configuration SFR (PC0PCF).

Table 25.1 through Table 25.3 are used with Equation 25.1 to calculate the average pull-up resistor current. Table 25.4 through Table 25.7 give the average current for all combinations.

$$I_{\text{pull-up}} = I_R \times D_{\text{SR}} \times D_{\text{PU}}$$

Equation 25.1. Average Pull-Up Current

Where:

I_R = Pull-up Resistor current selected by PC0PCF[4:2].

D_{SR} = Sample Rate Duty Cycle Multiplier selected by PC0MD[5:4].

D_{PU} = Pull-Up Duty Cycle Multiplier selected by PC0PCF[4:2].

Table 25.1. Pull-Up Resistor Current

PC0PCF[4:2]	I_R
000	0
001	1 μA
010	4 μA
011	16 μA
100	64 μA
101	256 μA
110	1 mA
111	4 mA

Table 25.2. Sample Rate Duty-Cycle Multiplier

PC0MD[5:4]	D_{SR}
00	1
01	1/2
10	1/4
11	1/8

Table 25.3. Pull-Up Duty-Cycle Multiplier

PC0PCF[1:0]	D_{PU}
00	1/4
01	3/8
10	1/2
11	3/4

Table 25.4. Average Pull-Up Current (Sample Rate = 250 μ s)

PC0PCF[1:0]	PC0PCF[4:2]								Duty Cycle
	000	001	010	011	100	101	110	111	
00	disabled	250 nA	1.0 μ A	4.0 μ A	16 μ A	64 μ A	250 μ A	1000 μ A	25%
01	disabled	375 nA	1.5 μ A	6.0 μ A	24 μ A	96 μ A	375 μ A	1500 μ A	37.5%
10	disabled	500 nA	2.0 μ A	8.0 μ A	32 μ A	128 μ A	500 μ A	2000 μ A	50%
11	disabled	750 nA	3.0 μ A	12.0 μ A	48 μ A	192 μ A	750 μ A	3000 μ A	75%

Table 25.5. Average Pull-Up Current (Sample Rate = 500 μ s)

PC0PCF[1:0]	PC0PCF[4:2]								Duty Cycle
	000	001	010	011	100	101	110	111	
00	disabled	125 nA	0.50 μ A	2.0 μ A	8 μ A	32 μ A	125 μ A	500 μ A	12.5%
01	disabled	188 nA	0.75 μ A	3.0 μ A	12 μ A	48 μ A	188 μ A	750 μ A	18.8%
10	disabled	250 nA	1.0 μ A	4.0 μ A	16 μ A	64 μ A	250 μ A	1000 μ A	25%
11	disabled	375 nA	1.5 μ A	6.0 μ A	24 μ A	96 μ A	375 μ A	1500 μ A	37.5%

Table 25.6. Average Pull-Up Current (Sample Rate = 1 ms)

PC0PCF[1:0]	PC0PCF[4:2]								Duty Cycle
	000	001	010	011	100	101	110	111	
00	disabled	63 nA	250 nA	1.0 μ A	4 μ A	16 μ A	63 μ A	250 μ A	6.3%
01	disabled	94 nA	375 nA	1.5 μ A	6 μ A	24 μ A	94 μ A	375 μ A	9.4%
10	disabled	125 nA	500 nA	2.0 μ A	8 μ A	32 μ A	125 μ A	500 μ A	12.5%
11	disabled	188 nA	750 nA	3.0 μ A	12 μ A	48 μ A	188 μ A	750 μ A	18.8%

Table 25.7. Average Pull-Up Current (Sample Rate = 2 ms)

PC0PCF[1:0]	PC0PCF[4:2]								Duty Cycle
	000	001	010	011	100	101	110	111	
00	disabled	31 nA	125 nA	0.50 μ A	2.0 μ A	8 μ A	31 μ A	125 μ A	3.1%
01	disabled	47 nA	188 nA	0.75 μ A	3.0 μ A	12 μ A	47 μ A	188 μ A	4.7%
10	disabled	63 nA	250 nA	1.0 μ A	4.0 μ A	16 μ A	63 μ A	250 μ A	6.3%
11	disabled	94 nA	375 nA	1.5 μ A	6.0 μ A	24 μ A	94 μ A	375 μ A	9.4%

25.4. Automatic Pull-Up Resistor Calibration

The pulse counter includes an automatic calibration engine which can automatically determine the minimum pull-up current for a particular application. The automatic calibration is especially useful when the load capacitance of field wiring varies from one installation to another.

The automatic calibration uses one of the pulse counter inputs (PC0 or PC1) for calibration. The CALPORT bit in the PC0PCF SFR selects either PC0 or PC1 for calibration. The reed switch on the selected input should be in the open state to allow the node to charge during calibration. The calibration engine can calibrate the pull-ups with the meter connected normally, provided that the reed switch is open during calibration. During calibration, the integrators will ignore the input comparators, and the counters will not be incremented. Using a 250 μ s sample rate and a 32 kHz RTCCLK, the calibration time will be 21 ms (28 tests @ 750 μ s each) or shorter depending on the pull up strength selected. The calibration will fail if the reed switch remains closed during this entire period. If the reed switch is both opened and closed during the calibration period, the value written into PCCF[4:0] may be larger than what is actually required. The transition flag in the PC0INT1 can detect when the reed switch opens, and most systems with a wheel rotation of 10 Hz or slower should have sufficient high time for the calibration to complete before the next closing of the reed switch. Slowing the sample rate will also increase the calibration time. The same drive strength will be used for both PC0 and PC1.

The example code for the pulse counter includes code for managing the automatic calibration engine.

25.5. Sample Rate

The pulse counter has a programmable sampling rate. The pulse counter samples the state of the reed switches at discrete time intervals based on the RTC clock. The PC0MD SFR sets the sampling rate. The system designer should carefully consider the maximum pulse rate for the particular application when setting the sampling rate and debounce time. Sample rates from 250 μ s to 2 ms can be selected to either further reduce power consumption or work with shorter pulse widths. The slowest sampling rate (2 ms) will provide the lowest possible power consumption.

25.6. Debounce

Like most mechanical switches, reed switches exhibit switch bouncing that could potentially result in false counts or quadrature errors. The pulse counter includes digital debounce logic using a digital integrator that can eliminate false counts due to switch bounce. The input of the integrator connects to the pulse counter inputs with the programmable pull-ups. The output connects to the counters.

The debounce integrator has two independent programmable thresholds: one for the rising edge (Debounce High) and one for the falling edge (Debounce Low). The PC0DCH (PC0 Debounce Config High) SFR sets the threshold for the rising edge. This SFR sets the number of cumulative high samples required to output a logic high to the counter. The PC0DCL (PC0 Debounce Config Low) SFR sets the threshold for the falling edge. This SFR sets the number of cumulative low samples required to output a logic low to the counter.

Note that the debounce does count consecutive samples. Requiring consecutive samples would be susceptible to noise. The digital integrator inherently filters out noise.

The system designer should carefully consider the maximum anticipated counter frequency and duty-cycle when setting the debounce time. If the debounce configuration is set too large, the pulse counter will not count short pulses. The debounce-high configuration should be set to less than one-half the minimum input pulse high-time. Similarly, the debounce-low configuration should be set to less than one-half the minimum input pulse low-time.

Figure 25.4 illustrates the operation of the debounce integrator. The top waveform is the representation of the reed switch (high: open, low: closed) which shows some random switch bounce. The bottom waveform is the final signal that goes into the counter which has the switch bounce removed. Based on the actual reed switch used and sample rate, the switch bounce time may appear shorter in duration than the example in Figure 25.4. The second waveform is the pull-up resistor enable signal. The enable signal enables

the pull-up resistor when high and disables when low. PC0 is the line to the reed switch. On the right side of PC0 waveform, the line voltage is decreasing towards ground when the pull-up resistors are disabled. Beneath the charging waveform, the arrows represent the sample points. The pulse counter samples the PC0 voltage once the charging completes. The sensed ones and zeros are the sampled data. Finally the integrator waveform illustrates the output of the digital integrator. The integrator is set to 4 initially and counts to down to 0 before toggling the output low. Once the integrator reaches the low state, it needs to count up to 4 before toggling its output to the high state. The debounce logic filters out switch bounce or noise that appears for a short duration.

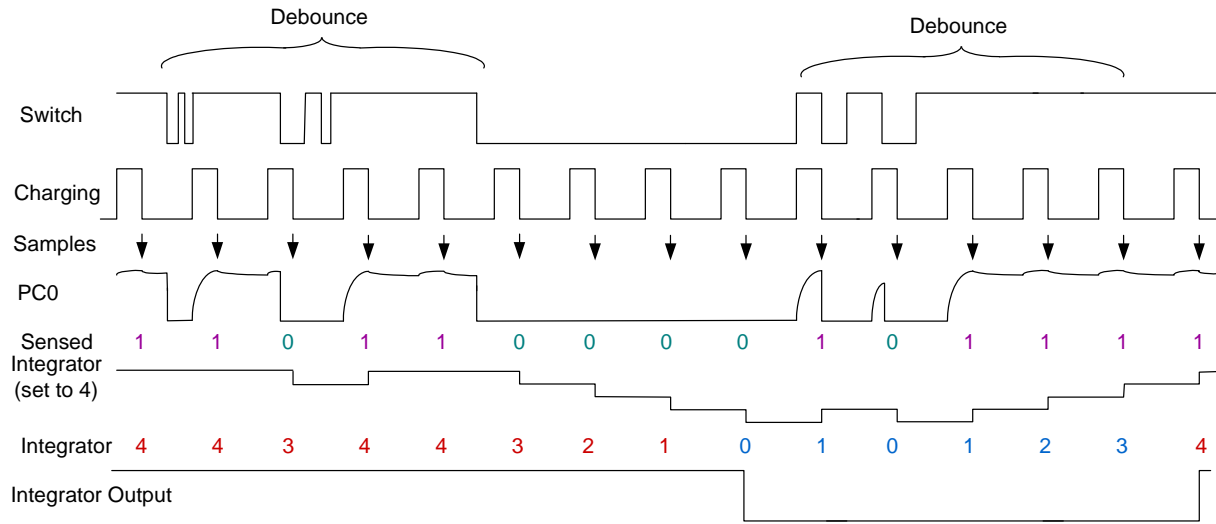

Figure 25.4. Debounce Timing

25.7. Reset Behavior

Unlike most MCU peripherals, an MCU reset does not completely reset the pulse counter. This includes a power on reset and all other reset sources. An MCU reset does not clear the counter values. The pulse counter SFRs do not reset to a default value upon reset. The 24-bit counter values are persistent unless cleared manually by writing to the PC0MD SFR. Note that if the VBAT voltage ever drops below the minimum operating voltage, this may compromise contents of the counters.

The PC0MD register should normally be written only once after reset. The PC0MD SFR is the master mode register. This register sets the counter mode and sample rate. Writing to the PC0MD SFR also resets the other PC0xxx SFRs.

Note that the RTC clock will reset on an MCU reset, so counting cannot resume until the RTC clock has been re-started.

Firmware should read the reset sources SFR RSTSRC to determine the source of the last reset and initialize the pulse counter accordingly.

When the pulse counter resets, it takes some time (typically two RTC clock cycles) to synchronize between internal clock domains. The counters do not increment during this synchronization time.

25.8. Wake up and Interrupt Sources

The pulse counter has multiple interrupt and wake-up source conditions. To enable an interrupt, enable the source in the PC0INT0/1 SFRs and enable the pulse counter interrupt using bit 4 of the EIE2 register. The pulse counter interrupt service routine should read the interrupt flags in PC0INT0/1 to determine the source of the interrupt and clear the interrupt flags.

To enable the pulse counter as a wake up source, enable the source in the PC0INT0/1 SFRs and enable the pulse counter as a wake-up source by setting bit 0 (PC0WK) to 1 in the PMU0FL SFR. Upon waking, firmware should read the PMCU0CF and PMU0FL SFRs to determine the wake-up source. If the PC0WK bit is set indicating that the pulse counter has woke the MCU, firmware should read the flag bits PC0INT0/1 SFRs to determine the pulse counter wake-up source and clear the flag bits before going back to sleep.

PC0INT0 includes the more common interrupt and wake-up sources. These include comparator match, counter overflow, and quadrature direction change. PC0INT1 includes interrupt and wake-up sources for the advanced features, including flutter detection and quadrature error.

25.9. Real-Time Register Access

Several of the pulse counter registers values change in real-time synchronous to the RTC clock. Hardware synchronization between the RTC clock domain and the system clock domain hardware would result in long delays when reading real-time registers. Instead, real-time register values are available instantaneously, but the read must be qualified using the read valid bit (PC0TH bit 0). If the register value does not change during the read access, the read valid bit will be set indicating the last was valid. If the value of the real-time register changes during the read access, the read valid bit is 0, indicating the read was invalid. After an invalid read, firmware must read the register and check the read valid bit again.

These 8-bit counter registers need to be qualified using the read valid bit:

- PC0STAT
- PC0HIST
- PC0INT0
- PC0INT1
- PC0CTR0L
- PC0CTC1L

The 24-bit counters are three-byte real-time read-only registers that require a special access method for reading. Firmware must read the low-byte (PC0CTR0L and PC0CTR1L) first and qualify using the read valid bit. Reading the low-byte latches the middle and high bytes. If the read valid bit is 0, the read is invalid and firmware must read the low-byte and check the read valid bit again. If the read valid bit is set, the read is valid and the middle and high bytes are also safe to read. Firmware should read the middle and high bytes only after reading the low byte and qualifying with the read valid bit.

The 24-bit comparators are three-byte real-time read-write registers that require a special access method for writing. Firmware must write the low-byte last. After writing the low-byte, it might take up to two RTC clock cycles for the new comparator value to take effect. System designers should consider the synchronization delay when setting the comparator value. The counter may be incremented before new comparator value takes effect. Setting the comparator to at least 2 counts above the current count will eliminate the chance of missing the comparator match during synchronization.

Example code is provided with accessor functions for all the real-time pulse counter registers.

25.10. Advanced Features

25.10.1. Quadrature Error

The quadrature encoder must only send valid quadrature codes. A valid quadrature sequence consists of four valid states. The quadrature codes are only permitted to transition to one of the adjacent states, and an invalid transition will result in a quadrature error. Note that a quadrature error is likely to occur when first enabling the quadrature counter mode, since the pulse counter state machine starts at the LL state and the initial state of the quadrature is arbitrary. It is safe to ignore the first quadrature error immediately after initialization.

25.10.2. Flutter Detection

The flutter detection can be used with either quadrature counter mode or dual counter mode when the two inputs are expected to be in step. Flutter refers to the case where one input continues toggling while the other input stops toggling. This may indicate a broken reed switch or a pressure oscillation when the wheel magnet stops at just the right distance from the reed switch. If a pressure oscillation causes a slight rotational oscillation in the wheel, it could cause a number of pulses on one of the inputs, but not on the other. All four edges are checked by the flutter detection feature (PC1 positive, PC1 negative, PC0 positive, and PC0 negative). When enabled, Flutter detection may be used as an interrupt or wake-up source.

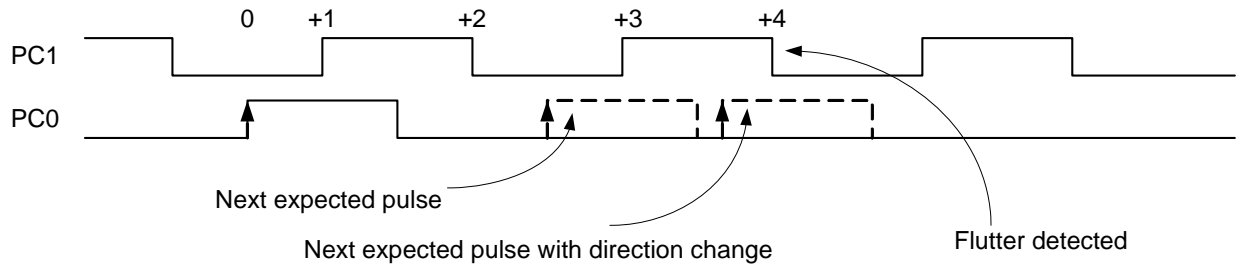

Figure 25.5. Flutter Example

For example, flutter detected on the PC0 positive edge means that 4 edges (positive or negative) were detected on PC1 since the last PC0 positive edge. Each PC0 positive edge resets the flutter detection counter while either PC1 edge increments the counter. There are similar counters for all four edges.

The flutter detection circuit provides interrupts or wake-up sources, but firmware must also read the pulse counter registers to determine what corrective action, if any, must be taken.

On the start of flutter event, the firmware should save both counter values and the PC0HIST register. Once the end of flutter event occurs the firmware should also save both counter values and the PC0HIST register. The stop count on flutter, STPCNTFLTR (PCMD[2]), be used to stop the counters when flutter is occurring (quadrature mode only). For quadrature mode, the opposite counter should be decremented by one. In other words, if the direction was clockwise, the counterclockwise counter (Counter 1) should be decremented by one to correct for one increment before flutter was detected. For dual mode, two reed switches can be used to get a redundant count. If flutter starts during dual mode, both counters should be saved by firmware. After flutter stops, both counters should be read again. The counter that incremented the most was the one that picked up the flutter. There is also a mode to switch from quadrature to dual (PC0MD[1]) when flutter occurs. This changes the counter style from quadrature (count on any edge of PC1 or PC0) to dual to allow all counts to be recorded. Once flutter ends, this mode switches the counters back to quadrature mode. STPCNTFLTR does not function when PC0MD[1] is set.

Si102x/3x

SFR Definition 25.1. PC0MD: PC0 Mode Configuration

Bit	7	6	5	4	3	2	1	0
Name	PCMODE[1:0]		PCRATE[1:0]		DUALCmpl	STPCNTFLTR	DUALSTCH	
Type	R/W		R/W		R/W	R	R/W	R
Reset	0	0	0	0	0	1	0	0

SFR Address = 0xD9; SFR Page = 0x2

Bit	Name	Function
7:6	PCMODE[1:0]	Counter Mode 00: Pulse Counter disabled. 01: Single Counter mode. 10: Dual Counter mode. 11: Quadrature Counter mode.
5:4	PCRATE[1:0]	PC Sample Rate 00: 250 μ s 01: 500 μ s 10: 1 ms 11: 2 ms
3	Reserved	
2	STPCNTFLTR	Stop Counting on Flutter (Only valid for quadrature counter mode and DUALSTCH off.) 0: Disabled. 1: Enabled.
1	DUALSTCH	Dual Mode Switch During Flutter (Only valid for quadrature counter mode.) 0: Disabled—quadrature mode remains set during flutter. 1: Enabled—quadrature mode changes to dual during flutter.
0	Reserved	

Note that writing to this register will clear the counter registers PC0CTR0H:M:L and PC0CTR1H:M:L.

SFR Definition 25.2. PC0PCF: PC0 Mode Pull-Up Configuration

Bit	7	6	5	4	3	2	1	0
Name	PUCAL	CALRES	CALPORT	RES[2:0]			DUTY[1:0]	
Type	R/W	R	R/W	R/W	R/W	R/W	R/W	R/W
Reset	0	1	0	0	0	1	0	0

SFR Address = 0xD7; SFR Page = 0x2

Bit	Name	Function
7	PUCAL	Pull-Up Driver Calibration 0: Calibration complete or not running. 1: Start calibration of pull up (Self clearing). Calibration determines the lowest usable pull-up strength.
6	CALRES	Calibration Result 0: Fail (switch may be closed preventing detection of pull ups). Writes value of 0x11111 to PC0PCF[4:0] 1: Pass (writes calibrated value into PC0PCF[4:0]).
5	CALPORT	Calibration Port 0: Calibration on PC0 only. 1: Calibration on PC1 only.
4:2	RES[2:0]	Pull-Up Resistor Select Current with force pull-up on bit set (PC0TH.2=1) and VBAT=3.6V. 000: Pull-up disabled. 001: 1 μ A.* 010: 4 μ A.* 011: 16 μ A.* 100: 64 μ A.* 101: 256 μ A.* 110: 1 mA.* 111: 4 mA.* *The effective average pull-up current depends on selected resistor, pull-up resistor duty-cycle multiplier, and sample rate duty-cycle multiplier.
1:0	DUTY[1:0]	Pull-Up Resistor Duty Cycle Multiplier 000: 1/4 (25%)* 001: 3/8 (37.5%)* 010: 1/2 (50%)* 011: 3/4 (75%)* *The final pull-up resistor duty cycle is the sample rate duty-cycle multiplier times the pull-up duty-cycle multiplier.

Si102x/3x

SFR Definition 25.3. PC0TH: PC0 Threshold Configuration

Bit	7	6	5	4	3	2	1	0
Name	PCTTHRESHI[1:0]		PCTHRESLO[1:0]		PDOWN	PUP		RDVALID
Type	R/W		R/W		R/W	R/W	R	R/W
Reset	0	0	0	0	0	0	0	1

SFR Address = 0xE4; SFR Page = 0x2

Bit	Name	Function
7:6	PCTTHRESHI[1:0]	Pulse Counter Input Comparator VIH Threshold (Percentage of VIO.) 10: 50% 11: 55% 00: 59% 01: 63%
5:4	PCTHRESLO[1:0]	Pulse Counter Input Comparator VIL Threshold (percentage of VIO.) 10: 34% 11: 38% 00: 42% 01: 46%
3	PDOWN	Force Pull-Down On 0: PC0 and PC1 pull-down not forced on. 1: PC0 and PC1 grounded.
2	PUP	Force Pull-Up 0: PC0 and PC1 pull-up not forced on continuously. See PC0PCF[1:0] for duty cycle. 1: PC0 and PC1 pulled high continuously to the PC0PCF[4:2] setting. PDOWN overrides PUP setting.
1	Reserved	
0	RDVALID	Read Valid Holds the status of the last read for real-time registers PC0STAT, PC0HIST, PC0CTRL, PC0CTR1L, PC0INT0, and PC0INT1. 0: The last read was invalid. 1: The last read was valid. RDVALID is set back to 1 upon reading.

SFR Definition 25.4. PC0STAT: PC0 Status

Bit	7	6	5	4	3	2	1	0
Name	FLUTTER	DIRECTION	STATE[1:0]		PC1PREV	PC0PREV	PC1	PC0
Type	RO	RO	RO		RO	RO	RO	RO
Reset	0	0	0	0	0	0	0	0

SFR Address = 0xC1; SFR Page = 0x2

Bit	Name	Function
7	FLUTTER	<p>Flutter</p> <p>During quadrature mode, a disparity may occur between the number of negative edges of PC1 and PC0 or the number of positive edges of PC1 and PC0. This could indicate flutter on one reed switch or one reed switch may be faulty.</p> <p>0: No flutter detected. 1: Flutter detected.</p>
6	DIRECTION	<p>Direction</p> <p>Only applicable for quadrature mode. (First letter is PC1; second letter is PC0)</p> <p>0: Counter clock-wise - (LL-LH-HH-HL) 1: Clock-wise - (LL-HL-HH-LH)</p>
5:4	STATE[1:0]	<p>PC0 State</p> <p>Current State of Internal State Machine.</p>
3	PC1PREV	<p>PC1 Previous</p> <p>Previous Output of PC1 Integrator.</p>
2	PC0PREV	<p>PC0 Previous</p> <p>Previous Output of PC0 Integrator.</p>
1	PC1	<p>PC1</p> <p>Current Output of PC1 Integrator.</p>
0	PC0	<p>PC0</p> <p>Current Output of PC0 Integrator.</p>

Si102x/3x

SFR Definition 25.5. PC0DCH: PC0 Debounce Configuration High

Bit	7	6	5	4	3	2	1	0
Name	PC0DCH[7:0]							
Type	R/W							
Reset	0	0	0	0	0	1	0	0

SFR Address = 0xFA; SFR Page = 0x2

Bit	Name	Function
7:0	PC0DCH[7:0]	Pulse Counter Debounce High Number of cumulative good samples seen by the integrator before recognizing the input as high. Sampling a low will decrement the count while sampling a high will increment the count. The actual value used is PC0DCH plus one. Switch bounce produces a random looking signal. The worst case would be to bounce low at each sample point and not start incrementing the integrator until the switch bounce settled. Therefore, minimum pulse width should account for twice the debounce time. For example, using a sample rate of 250 μ s and a PC0DCH value of 0x13 will look for 20 cumulative highs before recognizing the input as high ($250 \mu\text{s} \times (16+3+1) = 5 \text{ ms}$).

SFR Definition 25.6. PC0DCL: PC0 Debounce Configuration Low

Bit	7	6	5	4	3	2	1	0
Name	PC0DCL[7:0]							
Type	R/W							
Reset	0	0	0	0	0	1	0	0

SFR Address = 0xF9; SFR Page = 0x2

Bit	Name	Function
7:0	PC0DCL[7:0]	<p>Pulse Counter Debounce Low</p> <p>Number of cumulative good samples seen by the integrator before recognizing the input as low. Setting PC0DCL to 0x00 will disable integrators on both PC0 and PC1. The actual value used is PC0DCL plus one. Sampling a low decrements while sampling a high increments the count. Switch bounce produces a random looking signal. The worst case would be to bounce high at each sample point and not start decrementing the integrator until the switch bounce settled. Therefore, minimum pulse width should account for twice the debounce time. For example, using a sample rate of 1 ms and a PC0DCL value of 0x09 will look for 10 cumulative lows before recognizing the input as low (1 ms x 10 = 10 ms). The minimum pulse width should be 20 ms or greater for this example. If PC0DCL has a value of 0x03 and the sample rate is 500 μs, the integrator would need to see 4 cumulative lows before recognizing the low (500 μs x 4 = 2 ms). The minimum pulse width should be 4 ms for this example.</p>

Si102x/3x

SFR Definition 25.7. PC0CTR0H: PC0 Counter 0 High (MSB)

Bit	7	6	5	4	3	2	1	0
Name	PC0CTR0H[23:16]							
Type	R							
Reset	0	0	0	0	0	0	0	0

SFR Address = 0xDC; SFR Page = 0x2

Bit	Name	Function
7:0	PC0CTR0H[23:16]	PC0 Counter 0 High Byte Bits 23:16 of Counter 0.

SFR Definition 25.8. PC0CTR0M: PC0 Counter 0 Middle

Bit	7	6	5	4	3	2	1	0
Name	PC0CTR0M[15:8]							
Type	R							
Reset	0	0	0	0	0	0	0	0

SFR Address = 0xD8; SFR Page = 0x2

Bit	Name	Function
7:0	PC0CTR0M[15:8]	PC0 Counter 0 Middle Byte Bits 15:8 of Counter 0.

SFR Definition 25.9. PC0CTR0L: PC0 Counter 0 Low (LSB)

Bit	7	6	5	4	3	2	1	0
Name	PC0CTR0L[7:0]							
Type	R							
Reset	0	0	0	0	0	0	0	0

SFR Address = 0xDA; SFR Page = 0x2

Bit	Name	Function
7:0	PC0CTR0L[7:0]	PC0 Counter 0 Low Byte Bits 7:0 of Counter 0.

Note: PC0CTR0L must be read before PC0CTR0M and PC0CTR0H to latch the count for reading. PC0CTRL must be qualified using the RDVALID bit (PC0TH[0]).

SFR Definition 25.10. PC0CTR1H: PC0 Counter 1 High (MSB)

Bit	7	6	5	4	3	2	1	0
Name	PC0CTR1H[23:16]							
Type	R							
Reset	0	0	0	0	0	0	0	0

SFR Address = 0xDF; SFR Page = 0x2

Bit	Name	Function
7:0	PC0CTR1H[23:16]	PC0 Counter 1 High Byte Bits 23:16 of Counter 1.

SFR Definition 25.11. PC0CTR1M: PC0 Counter 1 Middle

Bit	7	6	5	4	3	2	1	0
Name	PC0CTR1M[15:8]							
Type	R							
Reset	0	0	0	0	0	0	0	0

SFR Address = 0xDE; SFR Page = 0x2

Bit	Name	Function
7:0	PC0CTR1M[15:8]	PC0 Counter 1 Middle Byte Bits 15:8 of Counter 1.

SFR Definition 25.12. PC0CTR1L: PC0 Counter 1 Low (LSB)

Bit	7	6	5	4	3	2	1	0
Name	PC0CTR1L[7:0]							
Type	R							
Reset	0	0	0	0	0	0	0	0

SFR Address = 0xDD; SFR Page = 0x2

Bit	Name	Function
7:0	PC0CTR1L[7:0]	PC0 Counter 1 Low Byte Bits 7:0 of Counter 1.

Note: PC0CTR1L must be read before PC0CTR1M and PC0CTR1H to latch the count for reading.

Si102x/3x

SFR Definition 25.13. PC0CMP0H: PC0 Comparator 0 High (MSB)

Bit	7	6	5	4	3	2	1	0
Name	PC0CMP0H[23:16]							
Type	R/W							
Reset	0	0	0	0	0	0	0	0

SFR Address = 0xE3; SFR Page = 0x2

Bit	Name	Function
7:0	PC0CMP0H[23:16]	PC0 Comparator 0 High Byte Bits 23:16 of Counter 0.

SFR Definition 25.14. PC0CMP0M: PC0 Comparator 0 Middle

Bit	7	6	5	4	3	2	1	0
Name	PC0CMP0M[15:8]							
Type	R/W							
Reset	0	0	0	0	0	0	0	0

SFR Address = 0xE2; SFR Page = 0x2

Bit	Name	Function
7:0	PC0CMP0M[15:8]	PC0 Comparator 0 Middle Byte Bits 15:8 of Counter 0.

SFR Definition 25.15. PC0CMP0L: PC0 Comparator 0 Low (LSB)

Bit	7	6	5	4	3	2	1	0
Name	PC0CMP0L[7:0]							
Type	R/W							
Reset	0	0	0	0	0	0	0	0

SFR Address = 0xE1; SFR Page = 0x2

Bit	Name	Function
7:0	PC0CMP0L[7:0]	PC0 Comparator 0 Low Byte Bits 7:0 of Counter 0.

Note: PC0CMP0L must be written last after writing PC0CMP0M and PC0CMP0H. After writing PC0CMP0L, the synchronization into the PC clock domain can take 2 RTC clock cycles.

SFR Definition 25.16. PC0CMP1H: PC0 Comparator 1 High (MSB)

Bit	7	6	5	4	3	2	1	0
Name	PC0CMP1H[23:16]							
Type	R/W							
Reset	0	0	0	0	0	0	0	0

SFR Address = 0xF3; SFR Page = 0x2

Bit	Name	Function
7:0	PC0CMP1H[23:16]	PC0 Comparator 1 High Byte Bits 23:16 of Counter 0.

SFR Definition 25.17. PC0CMP1M: PC0 Comparator 1 Middle

Bit	7	6	5	4	3	2	1	0
Name	PC0CMP1M[15:8]							
Type	R/W							
Reset	0	0	0	0	0	0	0	0

SFR Address = 0xF2; SFR Page = 0x2

Bit	Name	Function
7:0	PC0CMP1M[15:8]	PC0 Comparator 1 Middle Byte Bits 15:8 of Counter 0.

SFR Definition 25.18. PC0CMP1L: PC0 Comparator 1 Low (LSB)

Bit	7	6	5	4	3	2	1	0
Name	PC0CMP1L[7:0]							
Type	R/W							
Reset	0	0	0	0	0	0	0	0

SFR Address = 0xF1; SFR Page = 0x2

Bit	Name	Function
7:0	PC0CMP1L[7:0]	PC0 Comparator 1 Low Byte Bits 7:0 of Counter 0.

Note: PC0CMP1L must be written last after writing PC0CMP1M and PC0CMP1H. After writing PC0CMP1L the synchronization into the PC clock domain can take 2 RTC clock cycles.

Si102x/3x

SFR Definition 25.19. PC0HIST: PC0 History

Bit	7	6	5	4	3	2	1	0
Name	PC0HIST[7:0]							
Type	R							
Reset	0	0	0	0	0	0	0	0

SFR Address = 0xF4; SFR Page = 0x2

Bit	Name	Function
7:0	PC0HIST[7:0]	PC0 History. Contains the last 8 recorded directions (1: clock-wise, 0: counter clock-wise) on the previous 8 counts. Values of 0x55 or 0xAA may indicate flutter during quadrature mode.

SFR Definition 25.20. PC0INT0: PC0 Interrupt 0

Bit	7	6	5	4	3	2	1	0
Name	CMP1F	CMP1EN	CMP0F	CMP0EN	OVRF	OVREN	DIRCHGF	DIRCHGEN
Type	R/W	R/W	R/W	R/W	R/W	R/W	R/W	R/W
Reset	0	0	0	0	0	0	0	0

SFR Address = 0xFB; SFR Page = 0x2

Bit	Name	Function
7	CMP1F	Comparator 1 Flag 0: Counter 1 did not match comparator 1 value. 1: Counter 1 matched comparator 1 value.
6	CMP1EN	Comparator 1 Interrupt/Wake-up Source Enable 0: CMP1F not enabled as interrupt or wake-up source. 1: CMP1F enabled as interrupt or wake-up source.
5	CMP0F	Comparator 0 Flag 0: Counter 0 did not match comparator 0 value. 1: Counter 0 matched comparator 0 value.
4	CMP0EN	Comparator 0 Interrupt/Wake-up Source Enable 0: CMP0F not enabled as interrupt or wake-up source. 1: CMP0F enabled as interrupt or wake-up source.
3	OVRF	Counter Overflow Flag 1: Neither of the counters has overflowed. 1: One of the counters has overflowed.
2	OVREN	Counter Overflow Interrupt/Wake-up Source Enable 0: OVRF not enabled as interrupt or wake-up source. 1: OVRF enabled as interrupt or wake-up source.
1	DIRCHGF	Direction Change Flag Direction changed for quadrature mode only. 0: No change in direction detected. 1: Direction Change detected.
0	DIRCHGEN	Direction Change Interrupt/Wake-up Source Enable 0: DIRCHGF not enabled as interrupt or wake-up source. 1: DIRCHGF enabled as interrupt or wake-up source.

Si102x/3x

SFR Definition 25.21. PC0INT1: PC0 Interrupt 1

Bit	7	6	5	4	3	2	1	0
Name	FLTRSTRF	FLTRSTREN	FLTRSTPF	FLTRSTPEN	ERRORF	ERROREN	TRANSF	TRANSEN
Type	R/W	R/W	R/W	R/W	R/W	R/W	R/W	R/W
Reset	0	0	0	0	0	0	0	0

SFR Address = 0xFC; SFR Page = 0x2

Bit	Name	Function
7	FLTRSTRF	Flutter Start Flag Flutter detection for quadrature mode or dual mode only. 0: No flutter detected. 1: Start of flutter detected.
6	FLTRSTREN	Flutter Start Interrupt/Wake-up Source Enable 0:FLTRSTRF not enabled as interrupt or wake-up source. 1:FLTRSTRF enabled as interrupt or wake-up source.
5	FLTRSTPF	Flutter Stop Flag Flutter detection for quadrature mode or dual mode only. 0: No flutter stop detected. 1: Flutter stop detected.
4	FLTRSTPEN	Flutter Stop Interrupt/Wake-up Source Enable 0:FLTRSTPF not enabled as interrupt or wake-up source. 1:FLTRSTPF enabled as interrupt or wake-up source.
3	ERRORF	Quadrature Error Flag 0: No Quadrature Error detected. 1: Quadrature Error detected.
2	ERROREN	Quadrature Error Interrupt/Wake-up Source Enable 0:ERRORF not enabled as interrupt or wake-up source. 1:ERRORF enabled as interrupt or wake-up source.
1	TRANSF	Transition Flag 0: No transition detected. 1: Transition detected on PC0 or PC1.
0	TRANSEN	Transition Interrupt/Wake-up Source Enable 0: TRANSF not enabled as interrupt or wake-up source. 1: TRANSF enabled as interrupt or wake-up source.

26. LCD Segment Driver (Si102x Only)

Si102x devices contain an LCD segment driver and on-chip bias generation that supports static, 2-mux, 3-mux and 4-mux LCDs with 1/2 or 1/3 bias. The on-chip charge pump with programmable output voltage allows software contrast control which is independent of the supply voltage. LCD timing is derived from the SmaRTClock oscillator to allow precise control over the refresh rate.

The Si102x uses special function registers (SFRs) to store the enabled/disabled state of individual LCD segments. All LCD waveforms are generated on-chip based on the contents of the LCD0Dn registers. An LCD blinking function is also supported. A block diagram of the LCD segment driver is shown in Figure 26.1.

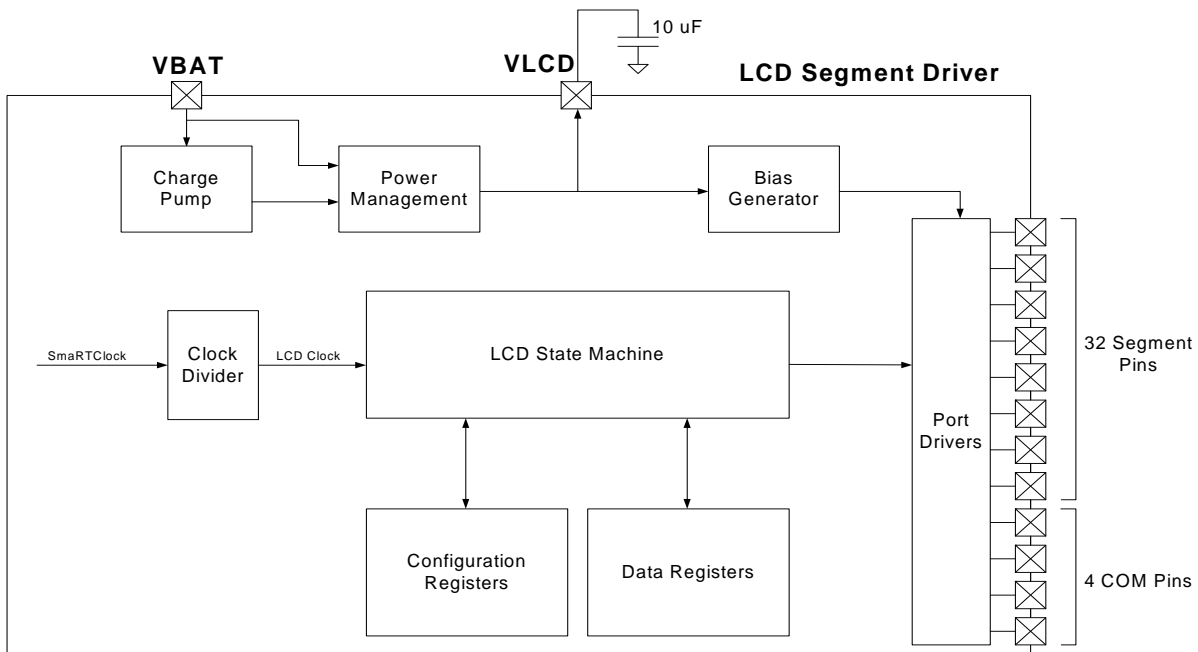

Figure 26.1. LCD Segment Driver Block Diagram

26.1. Configuring the LCD Segment Driver

The LCD segment driver supports multiple mux options: static, 2-mux, 3-mux, and 4-mux mode. It also supports 1/2 and 1/3 bias options. The desired mux mode and bias is configured through the LCD0CN register. A divide value may also be applied to the SmaRTClock output before being used as the LCD0 clock source.

The following procedure is recommended for using the LCD segment driver:

1. Initialize the SmaRTClock and configure the LCD clock divide settings in the LCD0CN register.
2. Determine the GPIO pins which will be used for the LCD function.
3. Configure the port I/O pins to be used for LCD as analog I/O.
4. Configure the LCD size, mux mode, and bias using the LCD0CN register.
5. Enable the LCD bias and clock gate by writing 0x50 to the LCD0MSCN register.
6. Configure the device for the desired Contrast Control Mode.
7. If VIO is internally or externally shorted to VBAT, disable the VLCD/VIO supply comparator using the

Si102x/3x

LCD0CF register.

8. Set the LCD contrast using the LCD0CNTRST register.
9. Set the desired threshold for the VBAT supply monitor.
10. Set the LCD refresh rate using the LCD0DIVH:LCD0DIVL registers.
11. Write a pattern to the LCD0Dn registers.
12. Enable the LCD by setting bit 0 of LCD0MSCN to logic 1 (LCD0MSCN |= 0x01).

26.2. Mapping Data Registers to LCD Pins

The LCD0 data registers are organized as 16 byte-wide special function registers (LCD0Dn), each half-byte or nibble in these registers controls 1 LCD output pin. There are 32 nibbles used to control the 32 segment pins.

Each LCD0 segment pin can control 1, 2, 3, or 4 LCD segments depending on the selected mux mode. The least significant bit of each nibble controls the segment connected to the backplane signal COM0. The next to least significant bit controls the segment associated with COM1, the next bit controls the segment associated with COM2, and the most significant bit in the 4-bit nibble controls the segment associated with COM3.

In static mode, only the least significant bit in each nibble is used and the three remaining bits in each nibble are ignored. In 2-mux mode, only the two least significant bits are used; in 3-mux mode, only the three least significant bits are used, and in 4-mux mode, each of the 4 bits in the nibble controls one LCD segment. Bits with a value of 1 turn on the associated segment and bits with a value of 0 turn off the associated segment.

SFR Definition 26.1. LCD0Dn: LCD0 Data

Bit	7	6	5	4	3	2	1	0
Name	LCD0Dn							
Type	R/W	R/W	R/W	R/W	R/W	R/W	R/W	R/W
Reset	0	0	0	0	0	0	0	0

SFR Page: 0x2

Addresses: LCD0D0 = 0x89, LCD0D1 = 0x8A, LCD0D2 = 0x8B, LCD0D3 = 0x8C,
 LCD0D4 = 0x8D, LCD0D5 = 0x8E, LCD0D6 = 0x91, LCD0D7 = 0x92,
 LCD0D8 = 0x93, LCD0D9 = 0x94, LCD0DA = 0x95, LCD0DB = 0x96,
 LCD0DC = 0x97, LCD0DD = 0x99, LCD0DE = 0x9A, LCD0DF = 0x9B.

Bit	Name	Function
7:0	LCD0Dn	LCD Data. Each nibble controls one LCD pin. See “26.2. Mapping Data Registers to LCD Pins” on page 342 for additional informatoin.

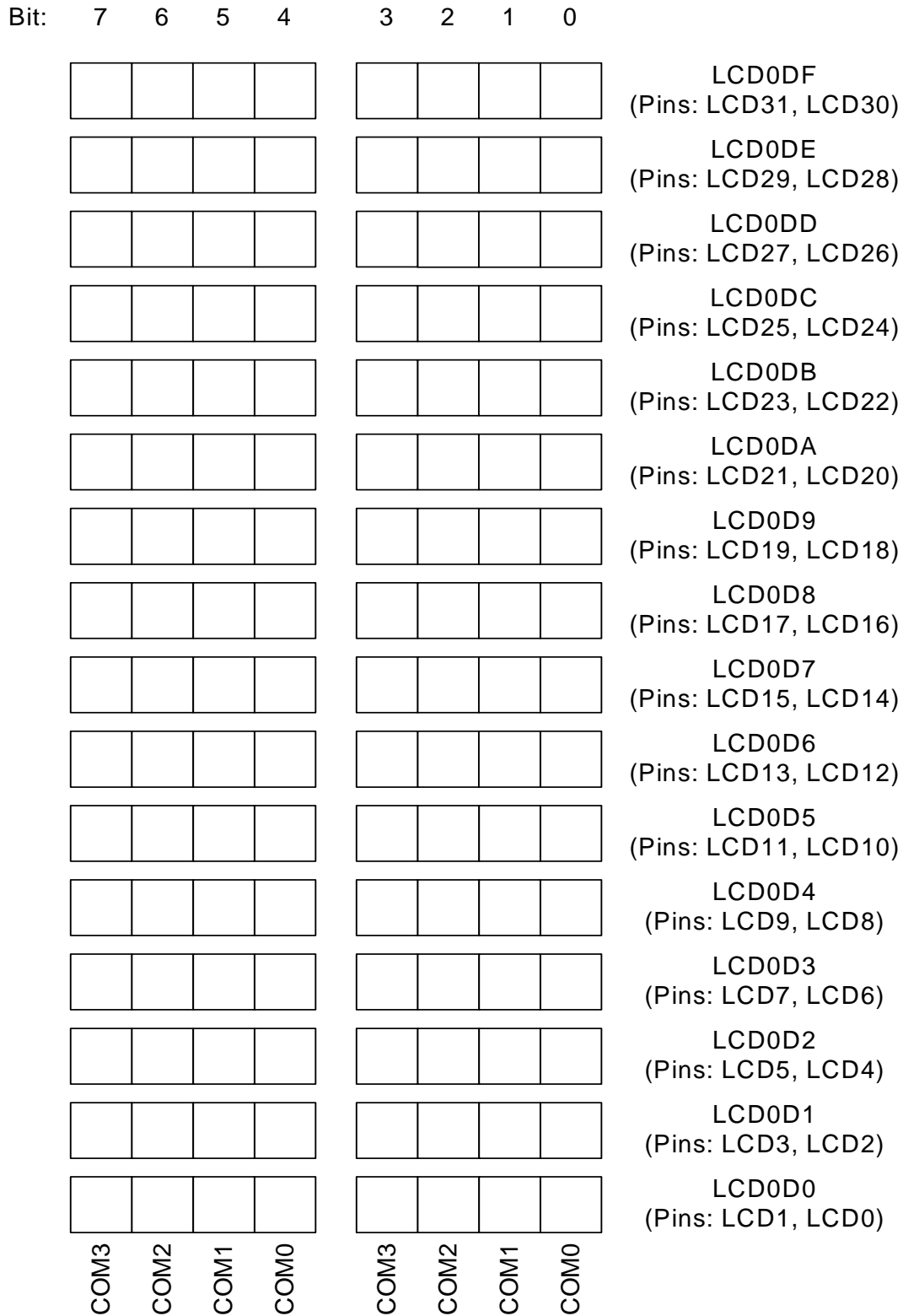

Figure 26.2. LCD Data Register to LCD Pin Mapping

Si102x/3x

SFR Definition 26.2. LCD0CN: LCD0 Control Register

Bit	7	6	5	4	3	2	1	0
Name		CLKDIV[1:0]		BLANK	SIZE	MUXMD[1:0]		BIAS
Type	R/W	R/W	R/W	R/W	R/W	R/W		R/W
Reset	0	0	0	0	0	0	0	0

SFR Page = 0x2; SFR Address = 0x9D

Bit	Name	Function
7	Reserved	Read = 0. Must Write 0b.
6:5	CLKDIV[1:0]	LCD0 Clock Divider. Divides the SmarTclock output for use by the LCD0 module. See Table 4.18 on page 68 for LCD clock frequency range. 00: The LCD clock is the SmarTclock divided by 1. 01: The LCD clock is the SmarTclock divided by 2. 10: The LCD clock is the SmarTclock divided by 4. 11: Reserved.
4	BLANK	Blank All Segments. Blanks all LCD segments using a single bit. 0: All LCD segments are controlled by the LCD0Dn registers. 1: All LCD segments are blank (turned off).
3	SIZE	LCD Size Select. Selects whether 16 or 32 segment pins will be used for the LCD function. 0: P0 and P1 are used as LCD segment pins. 1: P0, P1, P2, and P3 are used as LCD segment pins.
2:1	MUXMD[1:0]	LCD Bias Power Mode. Selects the mux mode. 00: Static mode selected. 01: 2-mux mode selected. 10: 3-mux mode selected. 11: 4-mux mode selected.
0	BIAS	Bias Select. Selects between 1/2 Bias and 1/3 Bias. This bit is ignored if Static mode is selected. 0: LCD0 is configured for 1/3 Bias. 1: LCD0 is configured for 1/2 Bias.

26.3. LCD Contrast Adjustment

The LCD Bias voltages which determine the LCD contrast are generated using the VBAT supply voltage or the on-chip charge pump. There are four contrast control modes to accommodate a wide variety of applications and supply voltages. The target contrast voltage is programmable in 60 mV steps from 1.9 to 3.72 V. The LCD contrast voltage is controlled by the LCD0CNTRST register and the contrast control mode is selected by setting the appropriate bits in the LCD0MSCN, LCD0MSCF, LCD0PWR, and LCD0VBMCN registers.

Note: An external 10 μ F decoupling capacitor is required on the VLCD pin to create a charge reservoir at the output of the charge pump.

Table 26.1. Bit Configurations to select Contrast Control Modes

Mode	LCD0MSCN.2	LCD0MSCF.0	LCD0PWR.3	LCD0VBMCN.7
1	0	1	0	0
2	0	1	1	1
3	1*	0	1	1
4	1*	0	0	1

* May be set to 0 to support increased load currents.

26.3.1. Contrast Control Mode 1 (Bypass Mode)

In Contrast Control Mode 1, the contrast control circuitry is disabled and the VLCD voltage follows the VBAT supply voltage, as shown in Figure 26.3. This mode is useful in systems where the VBAT voltage always remains constant and will provide the lowest LCD power consumption. Bypass Mode is selected using the following procedure:

1. Clear Bit 2 of the LCD0MSCN register to 0b (LCD0MSCN &= ~0x04)
2. Set Bit 0 of the LCD0MSCF register to 1b (LCD0MSCF |= 0x01)
3. Clear Bit 3 of the LCD0PWR register to 0b (LCD0PWR &= ~0x08)
4. Clear Bit 7 of the LCD0VBMCN register to 0b (LCD0VBMCN &= ~0x80)

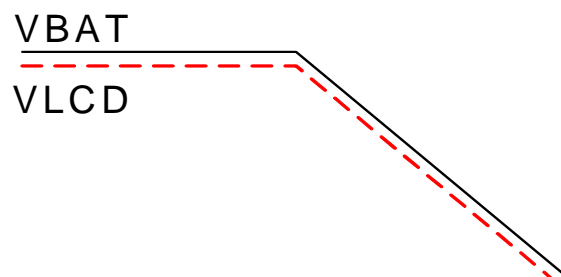

Figure 26.3. Contrast Control Mode 1

26.3.2. Contrast Control Mode 2 (Minimum Contrast Mode)

In Contrast Control Mode 2, a minimum contrast voltage is maintained, as shown in Figure 26.4. The VLCD supply is powered directly from VBAT as long as VBAT is higher than the programmable VBAT monitor threshold voltage. As soon as the VBAT supply monitor detects that VBAT has dropped below the programmed value, the charge pump will be automatically enabled in order to achieve the desired minimum contrast voltage on VLCD. Minimum Contrast Mode is selected using the following procedure:

1. Clear Bit 2 of the LCD0MSCN register to 0b (LCD0MSCN &= ~0x04)
2. Set Bit 0 of the LCD0MSCF register to 1b (LCD0MSCF |= 0x01)
3. Set Bit 3 of the LCD0PWR register to 1b (LCD0PWR |= 0x08)
4. Set Bit 7 of the LCD0VBMCN register to 1b (LCD0VBMCN |= 0x80)

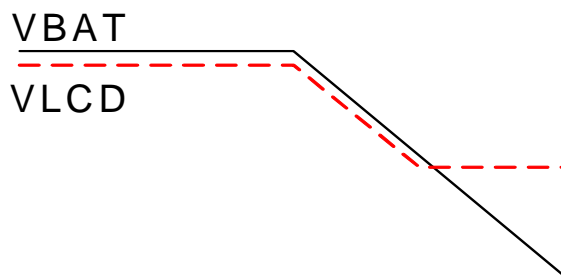

Figure 26.4. Contrast Control Mode 2

26.3.3. Contrast Control Mode 3 (Constant Contrast Mode)

In Contrast Control Mode 3, a constant contrast voltage is maintained. The VLCD supply is regulated to the programmed contrast voltage using a variable resistor between VBAT and VLCD as long as VBAT is higher than the programmable VBAT monitor threshold voltage. As soon as the VBAT supply monitor detects that VBAT has dropped below the programmed value, the charge pump will be automatically enabled in order to achieve the desired contrast voltage on VLCD. Constant Contrast Mode is selected using the following procedure:

1. Set Bit 2 of the LCD0MSCN register to 1b (LCD0MSCN |= 0x04)
2. Clear Bit 0 of the LCD0MSCF register to 0b (LCD0MSCF &= ~0x01)
3. Set Bit 3 of the LCD0PWR register to 1b (LCD0PWR |= 0x08)
4. Set Bit 7 of the LCD0VBMCN register to 1b (LCD0VBMCN |= 0x80)

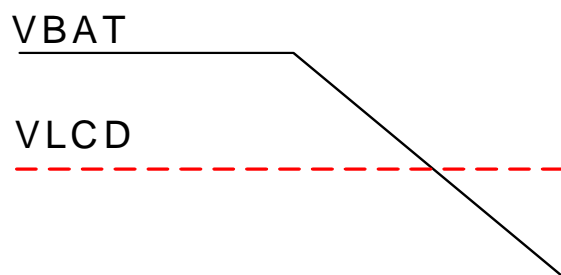

Figure 26.5. Contrast Control Mode 3

26.3.4. Contrast Control Mode 4 (Auto-Bypass Mode)

In Contrast Control Mode 4, behavior is identical to Constant Contrast Mode as long as VBAT is greater than the VBAT monitor threshold voltage. When VBAT drops below the programmed threshold, the device automatically enters bypass mode powering VLCD directly from VBAT. The charge pump is always disabled in this mode. Auto-Bypass Mode is selected using the following procedure:

1. Set Bit 2 of the LCD0MSCN register to 1b (LCD0MSCN |= 0x04)
2. Clear Bit 0 of the LCD0MSCF register to 0b (LCD0MSCF &= ~0x01)
3. Clear Bit 3 of the LCD0PWR register to 0b (LCD0PWR &= ~0x08)
4. Set Bit 7 of the LCD0VBMCN register to 1b (LCD0VBMCN |= 0x80)

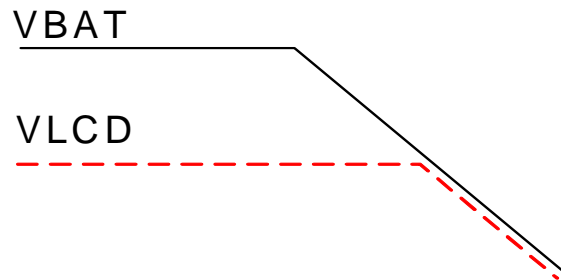

Figure 26.6. Contrast Control Mode 4

Si102x/3x

SFR Definition 26.3. LCD0CNTRST: LCD0 Contrast Adjustment

Bit	7	6	5	4	3	2	1	0
Name	Reserved	Reserved	Reserved	CNTRST				
Type	R/W	R/W	R/W	R/W				
Reset	0	0	0	0	0	0	0	0

SFR Page = 0x2; SFR Address = 0x9C

Bit	Name	Function
7:5	Reserved	Read = 000. Write = Must write 000.
4:0	CNTRST	<p>Contrast Setpoint.</p> <p>Determines the setpoint for the VLCD voltage necessary to achieve the desired contrast.</p> <ul style="list-style-type: none"> 00000: 1.90 00001: 1.96 00010: 2.02 00011: 2.08 00100: 2.13 00101: 2.19 00110: 2.25 00111: 2.31 01000: 2.37 01001: 2.43 01010: 2.49 01011: 2.55 01100: 2.60 01101: 2.66 01110: 2.72 01111: 2.78 10000: 2.84 10001: 2.90 10010: 2.96 10011: 3.02 10100: 3.07 10101: 3.13 10110: 3.19 10111: 3.25 11000: 3.31 11001: 3.37 11010: 3.43 11011: 3.49 11100: 3.54 11101: 3.60 11110: 3.66 11111: 3.72

SFR Definition 26.4. LCD0MSCN: LCD0 Master Control

Bit	7	6	5	4	3	2	1	0
Name		BIASEN	DCBIASOE	CLKOE		LOWDRV	LCDRST	LCDEN
Type	R/W	R/W	R/W	R/W	R/W	R/W	R/W	R/W
Reset	0	0	1	0	0	0	0	0

SFR Page = 0x2; SFR Address = 0xAB

Bit	Name	Function
7	Reserved	Read = 0b. Must write 0b.
6	BIASEN	LCD0 Bias Enable. LCD0 bias may be disabled when using a static LCD (single backplane), contrast control mode 1 (Bypass Mode) is selected, and the VLCD/VIO Supply Comparator is disabled (LCD0CF.5 = 1). It is required for all other modes. 0: LCD0 Bias is disabled. 1: LCD0 Bias is enabled
5	DCBIASOE	DCDC Converter Bias Output Enable. (Note 1) 0: The bias for the DCDC converter is gated off. 1: LCD0 provides the bias for the DCDC converter.
4	CLKOE	LCD Clock Output Enable. 0: The clock signal to the LCD0 module is gated off. 1: The SmartClock provides the undivided clock to the LCD0 Module.
3	Reserved	Read = 0b. Must write 0b.
2	LOWDRV	Charge Pump Reduced Drive Mode. This bit should be set to 1 in Contrast Control Mode 3 and Mode 4 for minimum power consumption. This bit may be set to 0 in these modes to support higher load current requirements. 0: The charge pump operates at full power. 1: The charge pump operates at reduced power.
1	LCDRST	LCD0 Reset. Writing a 1 to this bit will clear all the LCD0Dn registers to 0x00. This bit must be cleared by software.
0	LCDEN	LCD0 Enable. 0: LCD0 is disabled. 1: LCD0 is enabled.

Note 1: To same bias generator is shared by the dc-dc converter and LCD0.

SFR Definition 26.5. LCD0MSCF: LCD0 Master Configuration

Bit	7	6	5	4	3	2	1	0
Name							DCENSLP	CHPBYP
Type	R/W	R/W	R/W	R/W	R/W	R/W	R/W	R/W
Reset	1	1	1	1	1	1	1	0

SFR Page = 0x2; SFR Address = 0xAC

Bit	Name	Function
7:2	Reserved	Read = 111111b. Must write 111111b.
1	DCENSLP	DCDC Converter Enable in Sleep Mode 0: DCDC is disabled in Sleep Mode. 1: DCDC is enabled in Sleep Mode.
0	CHPBYP	LCD0 Charge Pump Bypass This bit should be set to 1b in Contrast Control Mode 1 and Mode 2. 0: LCD0 Charge Pump is not bypassed. 1: LCD0 Charge Pump is bypassed.

SFR Definition 26.6. LCD0PWR: LCD0 Power

Bit	7	6	5	4	3	2	1	0
Name					MODE			
Type	R/W	R/W	R/W	R/W	R/W	R/W	R/W	R/W
Reset	0	0	0	0	1	0	0	1

SFR Page = 0x2; SFR Address = 0xA4

Bit	Name	Function
7:4	Unused	Read = 0000b. Write = don't care.
3	MODE	LCD0 Contrast Control Mode Selection. 0: LCD0 Contrast Control Mode 1 or Mode 4 is selected. 1: LCD0 Contrast Control Mode 2 or Mode 3 is selected.
2:0	Reserved	Read = 001b. Must write 001b.

26.4. Adjusting the VBAT Monitor Threshold

The VBAT monitor is used primarily for the contrast control function, to detect when VBAT has fallen below a specific threshold. The VBAT monitor threshold may be set independently of the contrast setting or it may be linked to the contrast setting. When the VBAT monitor threshold is linked to the contrast setting, an offset (in 60mV steps) may be configured so that the VBAT monitor generates a VBAT low condition prior to VBAT dropping below the programmed contrast voltage. The LCD0VBM CN register is used to enable and configure the VBAT monitor. The VBAT monitor may be enabled as a wake-up source to wake up the device from Sleep mode when the battery is getting low. See “19. Power Management” on page 264 for more details.

SFR Definition 26.7. LCD0VBM CN: LCD0 VBAT Monitor Control

Bit	7	6	5	4	3	2	1	0
Name	VBATMEN	OFFSET		THRLD[4:0]				
Type	R/W	R/W	R/W	R/W				
Reset	0	0	0	0	0	0	0	0

SFR Page = 0x2; SFR Address = 0xA6

Bit	Name	Function
7	VBATMEN	<p>VBAT Monitor Enable</p> <p>The VBAT Monitor should be enabled in Contrast Control Mode 2, Mode 3, and Mode 4.</p> <p>0: The VBAT Monitor is disabled.</p> <p>1: The VBAT Monitor is enabled.</p>
6	OFFSET	<p>VBAT Monitor Offset Enable</p> <p>0: The VBAT Monitor Threshold is independent of the contrast setting.</p> <p>1: The VBAT Monitor Threshold is linked to the contrast setting.</p>
5	Unused	Read = 0. Write = Don't Care.
4:0	THRLD[4:0]	<p>VBAT Monitor Threshold</p> <p>If OFFSET is set to 0b, this bit field has the same definition as the CNTRST bit field and can be programmed independently of the contrast.</p> <p>If OFFSET is set to 1b, this bit field is interpreted as an offset to the currently programmed contrast setting. The LCD0CNTRST register should be written before setting OFFSET to logic 1 and should not be changed as long as VBAT Monitor Offset is enabled. When THRLD[4:0] is set to 00000b, the VBAT monitor threshold is equal to the contrast voltage. When THRLD[4:0] is set to 00001b, the VBAT monitor threshold is one step higher than the contrast voltage. The step size is equal to the step size of the CNTRST bit field.</p>

Si102x/3x

26.5. Setting the LCD Refresh Rate

The clock to the LCD0 module is derived from the SmarTClock and may be divided down according to the settings in the LCD0CN register. The LCD refresh rate is derived from the LCD0 clock and can be programmed using the LCD0DIVH:LCD0DIVL registers. The LCD mux mode must be taken into account when determining the prescaler value. See the LCD0DIVH/LCD0DIVL register descriptions for more details. For maximum power savings, choose a slow LCD refresh rate and the minimum LCD0 clock frequency. For the least flicker, choose a fast LCD refresh rate.

SFR Definition 26.8. LCD0CLKDIVH: LCD0 Refresh Rate Prescaler High Byte

Bit	7	6	5	4	3	2	1	0
Name	LCD0DIV[9:8]							
Type	R/W	R/W	R/W	R/W	R/W	R/W	R/W	
Reset	0	0	0	0	0	0	0	0

SFR Page = 0x2; SFR Address = 0xAA

Bit	Name	Function
7:2	Unused	Read = 000000. Write = Don't Care.
1:0	LCD0DIV[9:8]	LCD Refresh Rate Prescaler. Sets the LCD refresh rate according to the following equation: $\text{LCD Refresh Rate} = \frac{\text{LCD0 Clock Frequency}}{4 \times \text{mux_mode} \times (\text{LCD0DIV} + 1)}$

SFR Definition 26.9. LCD0CLKDIVL: LCD Refresh Rate Prescaler Low Byte

Bit	7	6	5	4	3	2	1	0
Name	LCD0DIV[7:0]							
Type	R/W							
Reset	0	0	0	0	0	0	0	0

SFR Page = 0x2; SFR Address = 0xA9

Bit	Name	Function
7:0	LCD0DIV[7:0]	LCD Refresh Rate Prescaler. Sets the LCD refresh rate according to the following equation: $\text{LCD Refresh Rate} = \frac{\text{LCD0 Clock Frequency}}{4 \times \text{mux_mode} \times (\text{LCD0DIV} + 1)}$

26.6. Blinking LCD Segments

The LCD driver supports blinking LCD applications such as clock applications where the “:” separator toggles on and off once per second. If the LCD is only displaying the hours and minutes, then the device only needs to wake up once per minute to update the display. The once per second blinking is automatically handled by the Si102x/3x.

The LCD0BLINK register can be used to enable blinking on any LCD segment connected to the LCD0 or LCD1 segment pin. In static mode, a maximum of 2 segments can blink. In 2-mux mode, a maximum of 4 segments can blink; in 3-mux mode, a maximum of 6 segments can blink; and in 4-mux mode, a maximum of 8 segments can blink. The LCD0BLINK mask register targets the same LCD segments as the LCD0D0 register. If an LCD0BLINK bit corresponding to an LCD segment is set to 1, then that segment will toggle at the frequency set by the LCD0TOGR register without any software intervention.

SFR Definition 26.10. LCD0BLINK: LCD0 Blink Mask

Bit	7	6	5	4	3	2	1	0
Name	LCD0BLINK[7:0]							
Type	R/W	R/W	R/W	R/W	R/W	R/W	R/W	R/W
Reset	0	0	0	0	0	0	0	0

SFR Page = 0x2; SFR Address = 0x9E

Bit	Name	Function
7:0	LCD0BLINK[7:0]	<p>LCD0 Blink Mask.</p> <p>Each bit maps to a specific LCD segment connected to the LCD0 and LCD1 segment pins. A value of 1 indicates that the segment is blinking. A value of 0 indicates that the segment is not blinking. This bit to segment mapping is the same as the LCD0D0 register.</p>

SFR Definition 26.11. LCD0TOGR: LCD0 Toggle Rate

Bit	7	6	5	4	3	2	1	0
Name					TOGR[3:0]			
Type	R/W	R/W	R/W	R/W	R/W			
Reset	0	0	0	0	0	0	0	0

SFR Page = 0x2; SFR Address = 0x9F

Bit	Name	Function
7:4	Unused	Read = 0000. Write = Don't Care.
3:0	TOGR[3:0]	<p>LCD Toggle Rate Divider. Sets the LCD Toggle Rate according to the following equation:</p> $\text{LCD Toggle Rate} = \frac{\text{Refresh Rate} \times \text{mux_mode} \times 2}{\text{Toggle Rate Divider}}$ <p>0000: Reserved. 0001: Reserved. 0010: Toggle Rate Divider is set to divide by 2. 0011: Toggle Rate Divider is set to divide by 4. 0100: Toggle Rate Divider is set to divide by 8. 0101: Toggle Rate Divider is set to divide by 16. 0110: Toggle Rate Divider is set to divide by 32. 0111: Toggle Rate Divider is set to divide by 64. 1000: Toggle Rate Divider is set to divide by 128. 1001: Toggle Rate Divider is set to divide by 256. 1010: Toggle Rate Divider is set to divide by 512. 1011: Toggle Rate Divider is set to divide by 1024. 1100: Toggle Rate Divider is set to divide by 2048. 1101: Toggle Rate Divider is set to divide by 4096. All other values reserved.</p>

26.7. Advanced LCD Optimizations

The special function registers described in this section should be left at their reset value for most systems. Some systems with specific low power or large load requirements will benefit from tweaking the values in these registers to achieve minimum power consumption or maximum drive level.

SFR Definition 26.12. LCD0CF: LCD0 Configuration

Bit	7	6	5	4	3	2	1	0
Name			CMPBYP					
Type	R/W	R/W	R/W	R/W	R/W	R/W	R/W	R/W
Reset	0	0	0	0	0	0	0	0

SFR Page = 0x2; SFR Address = 0xA5

Bit	Name	Function
7:6	Reserved	Read = 00b. Must write 00b.
5	CMPBYP	VLCD/VIO Supply Comparator Disable. Setting this bit to '1' disables the supply voltage comparator which determines if the VIO supply is lower than VLCD. This comparator should only be disabled, as a power saving measure, if VIO is internally or externally shorted to VBAT.
4:0	Reserved	Read = 00b. Must write 00000b.

SFR Definition 26.13. LCD0CHPCN: LCD0 Charge Pump Control

Bit	7	6	5	4	3	2	1	0
Name								
Type	R/W	R/W	R/W	R/W	R/W	R/W	R/W	R/W
Reset	0	1	0	0	1	0	1	1

SFR Page = 0x2; SFR Address = 0xB5

Bit	Name	Function
7:0	Reserved	Must write 0x4B.

Si102x/3x

SFR Definition 26.14. LCD0CHPCF: LCD0 Charge Pump Configuration

Bit	7	6	5	4	3	2	1	0
Name								
Type	R/W	R/W	R/W	R/W	R/W	R/W	R/W	R/W
Reset	0	1	1	0	0	0	0	0

SFR Page = 0x2; SFR Address = 0xAD

Bit	Name	Function
7:0	Reserved	Must write 0x60.

SFR Definition 26.15. LCD0CHPMD: LCD0 Charge Pump Mode

Bit	7	6	5	4	3	2	1	0
Name								
Type	R/W	R/W	R/W	R/W	R/W	R/W	R/W	R/W
Reset	1	1	1	0	1	0	0	1

SFR Page = 0x2; SFR Address = 0xAE

Bit	Name	Function
7:0	Reserved	Must write 0xE9.

SFR Definition 26.16. LCD0BUFCN: LCD0 Buffer Control

Bit	7	6	5	4	3	2	1	0
Name								
Type	R/W	R/W	R/W	R/W	R/W	R/W	R/W	R/W
Reset	0	1	0	0	0	1	0	0

SFR Page = 0xF; SFR Address = 0x9C

Bit	Name	Function
7:0	Reserved	Must write 0x44.

SFR Definition 26.17. LCD0BUF CF: LCD0 Buffer Configuration

Bit	7	6	5	4	3	2	1	0
Name								
Type	R/W	R/W	R/W	R/W	R/W	R/W	R/W	R/W
Reset	0	0	1	1	0	0	1	0

SFR Page = 0xF; SFR Address = 0xAC

Bit	Name	Function
7:0	Reserved	Must write 0x32.

SFR Definition 26.18. LCD0BUF MD: LCD0 Buffer Mode

Bit	7	6	5	4	3	2	1	0
Name								
Type	R/W	R/W	R/W	R/W	R/W	R/W	R/W	R/W
Reset	0	1	0	0	1	0	1	0

SFR Page = 0x2; SFR Address = 0xB6

Bit	Name	Function
7:0	Reserved	Must write 0x4A.

SFR Definition 26.19. LCD0VBM CF: LCD0 VBAT Monitor Configuration

Bit	7	6	5	4	3	2	1	0
Name								
Type	R/W	R/W	R/W	R/W	R/W	R/W	R/W	R/W
Reset	0	0	0	0	1	0	1	1

SFR Page = 0x2; SFR Address = 0xAF

Bit	Name	Function
7:0	Reserved	Must write 0x0B.

27. Port Input/Output

Digital and analog resources are available through 53 I/O pins. Port pins are organized as eight byte-wide ports. Port pins can be defined as digital or analog I/O. Digital I/O pins can be assigned to one of the internal digital resources or used as general purpose I/O (GPIO). Analog I/O pins are used by the internal analog resources. P7.0 can be used as GPIO and is shared with the C2 Interface Data signal (C2D). See Section “35. C2 Interface” on page 533 for more details.

The designer has complete control over which digital and analog functions are assigned to individual port pins. This resource assignment flexibility is achieved through the use of a Priority Crossbar Decoder. See Section 27.3 for more information on the Crossbar.

For port I/Os configured as push-pull outputs, current is sourced from the VIO or VIORF supply pin. See Section 27.1 for more information on port I/O operating modes and the electrical specifications chapter for detailed electrical specifications.

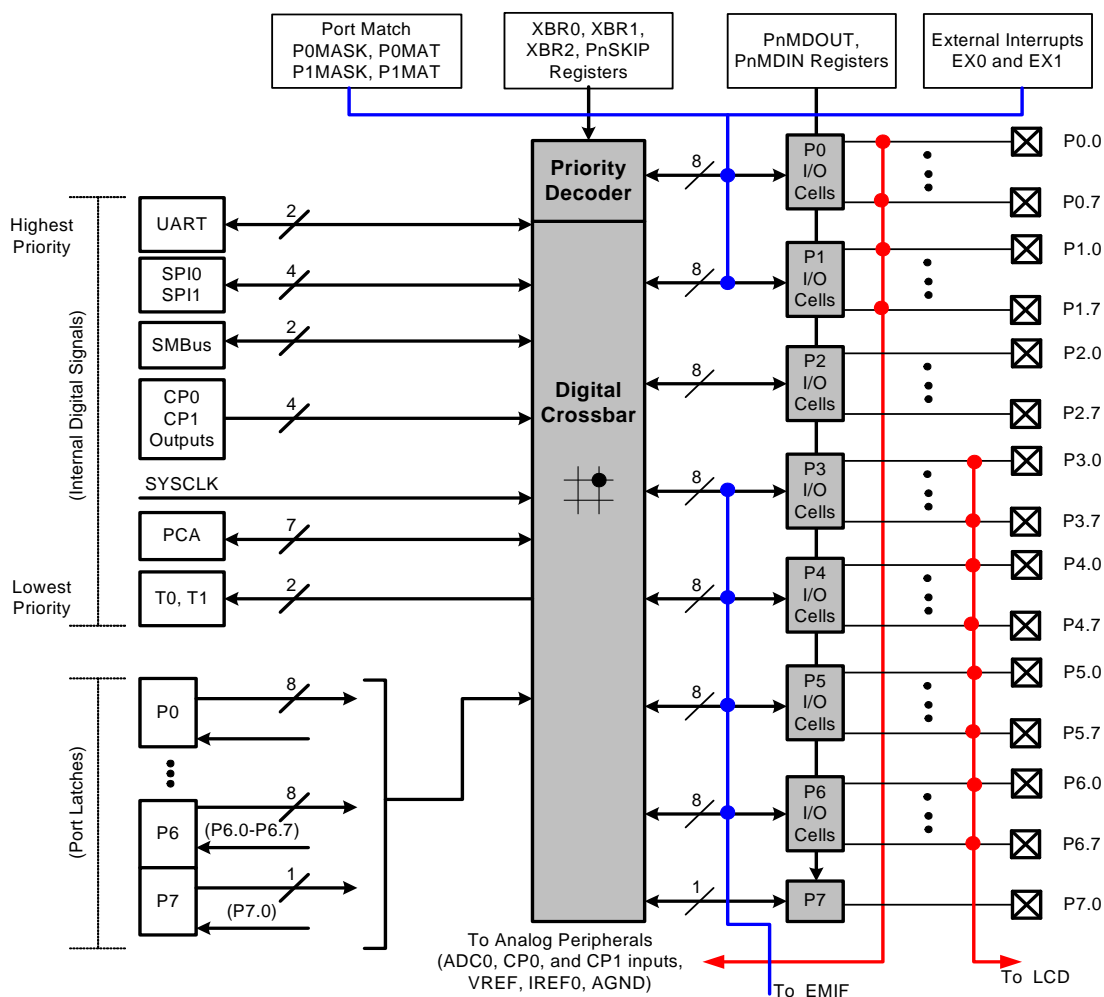

Figure 27.1. Port I/O Functional Block Diagram

27.1. Port I/O Modes of Operation

Port pins P0.0–P6.7 use the port I/O cell shown in Figure 27.2. The supply pin for P1.4 - P2.3 is VIORF and the supply for all other GPIOs is VIO. Each port I/O cell can be configured by software for analog I/O or digital I/O using the PnMDIN registers. P7.0 can only be used for digital functions and is shared with the C2D signal. On reset, all port I/O cells default to a digital high impedance state with weak pull-ups enabled.

27.1.1. Port Pins Configured for Analog I/O

Any pins to be used as comparator or ADC input, external oscillator input/output, or AGND, VREF, or current reference output should be configured for analog I/O (PnMDIN.n = 0). When a pin is configured for analog I/O, its weak pullup and digital receiver are disabled. In most cases, software should also disable the digital output drivers. port pins configured for analog I/O will always read back a value of 0 regardless of the actual voltage on the pin.

Configuring pins as analog I/O saves power and isolates the port pin from digital interference. Port pins configured as digital inputs may still be used by analog peripherals; however, this practice is not recommended and may result in measurement errors.

27.1.2. Port Pins Configured For Digital I/O

Any pins to be used by digital peripherals (UART, SPI, SMBus, etc.), external digital event capture functions, or as GPIO should be configured as digital I/O (PnMDIN.n = 1). For digital I/O pins, one of two output modes (push-pull or open-drain) must be selected using the PnMDOUT registers.

Push-pull outputs (PnMDOUT.n = 1) drive the port pad to the supply or GND rails based on the output logic value of the port pin. Open-drain outputs have the high side driver disabled; therefore, they only drive the port pad to GND when the output logic value is 0 and become high impedance inputs (both high and low drivers turned off) when the output logic value is 1.

When a digital I/O cell is placed in the high impedance state, a weak pull-up transistor pulls the port pad to the supply voltage to ensure the digital input is at a defined logic state. Weak pull-ups are disabled when the I/O cell is driven to GND to minimize power consumption and may be globally disabled by setting WEAKPUD to 1. The user must ensure that digital I/O are always internally or externally pulled or driven to a valid logic state. Port pins configured for digital I/O always read back the logic state of the port pad, regardless of the output logic value of the port pin.

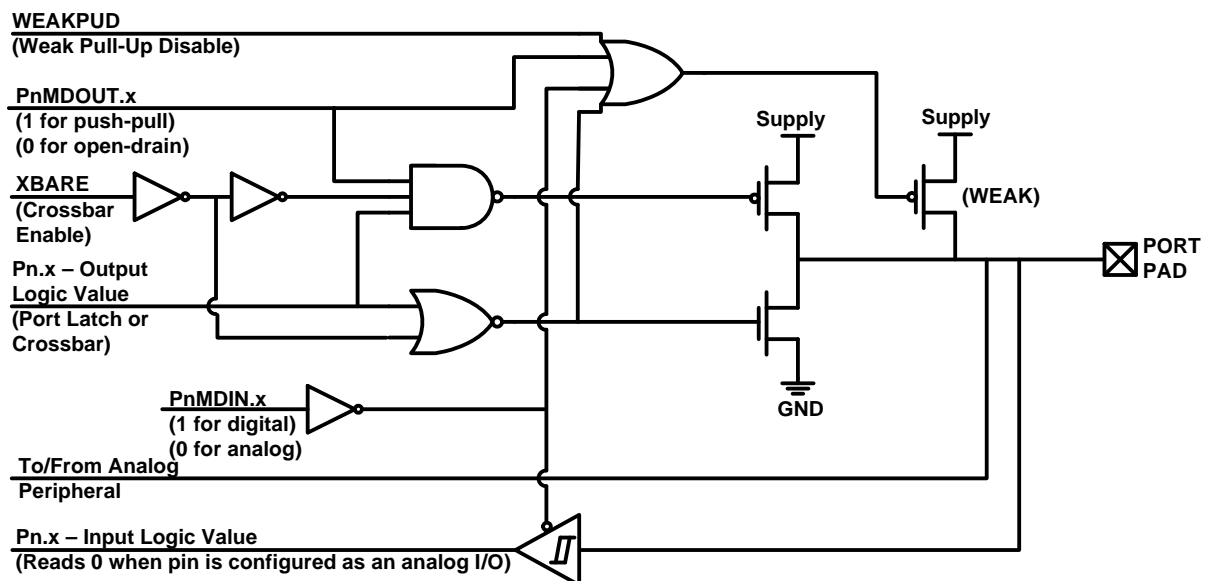

Figure 27.2. Port I/O Cell Block Diagram

27.1.3. Interfacing Port I/O to High Voltage Logic

All port I/O configured for digital, open-drain operation are capable of interfacing to digital logic operating at a supply voltage up to $V_{IO} + 2\text{ V}$. An external pull-up resistor to the higher supply voltage is typically required for most systems.

27.1.4. Increasing Port I/O Drive Strength

Port I/O output drivers support a high and low drive strength; the default is low drive strength. The drive strength of a port I/O can be configured using the PnDRV registers. See Section “4. Electrical Characteristics” on page 50 for the difference in output drive strength between the two modes.

27.2. Assigning Port I/O Pins to Analog and Digital Functions

Port I/O pins P0.0–P2.6 can be assigned to various analog, digital, and external interrupt functions. The port pins assigned to analog functions should be configured for analog I/O, and port pins assigned to digital or external interrupt functions should be configured for digital I/O.

27.2.1. Assigning Port I/O Pins to Analog Functions

Table 27.1 shows all available analog functions that need port I/O assignments. **Port pins selected for these analog functions should have their digital drivers disabled ($PnMDOUT.n = 0$ and Port Latch = 1) and their corresponding bit in PnSKIP set to 1.** This reserves the pin for use by the analog function and does not allow it to be claimed by the crossbar. Table 27.1 shows the potential mapping of port I/O to each analog function.

Table 27.1. Port I/O Assignment for Analog Functions

Analog Function	Potentially Assignable Port Pins	SFR(s) used for Assignment
ADC Input	P0.0–P0.7, P1.4–P2.3	ADCOMX, PnSKIP
Comparator0 Input	P0.0–P0.7, P1.4–P2.3	CPT0MX, PnSKIP
Comparator1 Input	P0.0–P0.7, P1.4–P2.3	CPT1MX, PnSKIP
LCD Pins (LCD0)	P2.4–P6.7	PnMDIN, PnSKIP
Pulse Counter (PC0)	P1.0, P1.1	P1MDIN, PnSKIP
Voltage Reference (VREF0)	P0.0	REF0CN, PnSKIP
Analog Ground Reference (AGND)	P0.1	REF0CN, PnSKIP
Current Reference (IREF0)	P0.7	IREF0CN, PnSKIP
External Oscillator Input (XTAL1)	P0.2	OSCXCN, PnSKIP
External Oscillator Output (XTAL2)	P0.3	OSCXCN, PnSKIP
SmaRTClock Input (XTAL3)	P1.2	P1MDIN, PnSKIP
SmaRTClock Output (XTAL4)	P1.3	P1MDIN, PnSKIP

27.2.2. Assigning Port I/O Pins to Digital Functions

Any port pins not assigned to analog functions may be assigned to digital functions or used as GPIO. Most digital functions rely on the crossbar for pin assignment; however, some digital functions bypass the crossbar in a manner similar to the analog functions listed above. **Port pins used by these digital functions and any port pins selected for use as GPIO should have their corresponding bit in PnSKIP set to 1.** Table 27.2 shows all available digital functions and the potential mapping of port I/O to each digital function.

Table 27.2. Port I/O Assignment for Digital Functions

Digital Function	Potentially Assignable Port Pins	SFR(s) used for Assignment
UART0, SPI0, SPI1, SMBus, CP0 and CP1 Outputs, System Clock Output, PCA0, Timer0 and Timer1 External Inputs.	Any port pin available for assignment by the crossbar. This includes P0.0–P2.7 pins which have their PnSKIP bit set to 0. Note: The crossbar will always assign UART0 and SPI1 pins to fixed locations.	XBR0, XBR1, XBR2
Any pin used for GPIO	P0.0–P7.0	P0SKIP, P1SKIP, P2SKIP
External Memory Interface	P3.6–P6.7	EMIOCF

27.2.3. Assigning Port I/O Pins to External Digital Event Capture Functions

External digital event capture functions can be used to trigger an interrupt or wake the device from a low power mode when a transition occurs on a digital I/O pin. The digital event capture functions do not require dedicated pins and will function on both GPIO pins (PnSKIP = 1) and pins in use by the crossbar (PnSKIP = 0). External digital even capture functions cannot be used on pins configured for analog I/O. Table 27.3 shows all available external digital event capture functions.

Table 27.3. Port I/O Assignment for External Digital Event Capture Functions

Digital Function	Potentially Assignable Port Pins	SFR(s) used for Assignment
External Interrupt 0	P0.0–P0.5, P1.6, P1.7	IT01CF
External Interrupt 1	P0.0–P0.4, P1.6, P1.7	IT01CF
Port Match	P0.0–P1.7	P0MASK, P0MAT P1MASK, P1MAT

27.3. Priority Crossbar Decoder

The Priority Crossbar Decoder assigns a port I/O pin to each software selected digital function using the fixed peripheral priority order shown in Figure 27.3. The registers XBR0, XBR1, and XBR2 defined in SFR Definition 27.1, SFR Definition 27.2, and SFR Definition 27.3 are used to select digital functions in the crossbar. The port pins available for assignment by the crossbar include all port pins (P0.0–P2.6) which have their corresponding bit in PnSKIP set to 0.

From Figure 27.3, the highest priority peripheral is UART0. If UART0 is selected in the crossbar (using the XBRn registers), then P0.4 and P0.5 will be assigned to UART0. The next highest priority peripheral is SPI1. If SPI1 is selected in the crossbar, then P2.0–P2.2 will be assigned to SPI1. P2.3 will be assigned if SPI1 is configured for 4-wire mode. The user should ensure that the pins to be assigned by the crossbar have their PnSKIP bits set to 0.

For all remaining digital functions selected in the crossbar, starting at the top of Figure 27.3 going down, the least-significant unskipped, unassigned port pin(s) are assigned to that function. If a port pin is already assigned (e.g., UART0 or SPI1 pins), or if its PnSKIP bit is set to 1, then the crossbar will skip over the pin and find next available unskipped, unassigned port pin. All port pins used for analog functions, GPIO, or dedicated digital functions such as the EMIF should have their PnSKIP bit set to 1.

Figure 27.3 shows the crossbar decoder priority with no port pins skipped (P0SKIP, P1SKIP, P2SKIP = 0x00); Figure 27.4 shows the crossbar decoder priority with the external oscillator pins (XTAL1 and XTAL2) skipped (P0SKIP = 0x0C).

Important Notes:

- The crossbar must be enabled (XBARE = 1) before any port pin is used as a digital output. Port output drivers are disabled while the crossbar is disabled.
- When SMBus is selected in the crossbar, the pins associated with SDA and SCL will automatically be forced into open-drain output mode regardless of the PnMDOUT setting.
- SPI0 can be operated in either 3-wire or 4-wire modes, depending on the state of the NSSMD1-NSSMD0 bits in register SPI0CN. The NSS signal is only routed to a port pin when 4-wire mode is selected. When SPI0 is selected in the crossbar, the SPI0 mode (3-wire or 4-wire) will affect the pinout of all digital functions lower in priority than SPI0.
- For given XBRn, PnSKIP, and SPInCN register settings, one can determine the I/O pin-out of the device using Figure 27.3 and Figure 27.4.

	P0								P1								P2							
SF Signals	VREF	AGND	XTAL1	XTAL2			CNVSTR	IREFO																
PIN I/O	0	1	2	3	4	5	6	7	0	1	2	3	4	5	6	7	0	1	2	3	4	5	6	7
TX0																								
RX0																								
SCK (SPI1)																								
MISO (SPI1)																								
MOSI (SPI1)																								
NSS* (SPI1)																								
SCK (SPI0)																								
MISO (SPI0)																								
MOSI (SPI0)																								
NSS* (SPI0)																								
SDA																								
SCL																								
CP0																								
CP0A																								
CP1																								
CP1A																								
/SYSCLK																								
CEX0																								
CEX1																								
CEX2																								
CEX3																								
CEX4																								
CEX5																								
ECl																								
T0																								
T1																								
	0	0	0	0	0	0	0	0	0	0	0	0	0	0	0	0	0	0	0	0	0	0	0	0
	P0SKIP[0:7]								P1SKIP[0:7]								P2SKIP[0:7]							

Figure 27.3. Crossbar Priority Decoder with No Pins Skipped

Si102x/3x

	P0								P1								P2							
SF Signals	VREF	AGND	XTAL1	XTAL2	CNVSTR	IREFO																		
PIN I/O	0	1	2	3	4	5	6	7	0	1	2	3	4	5	6	7	0	1	2	3	4	5	6	7
TX0					■																			
RX0						■																		
SCK (SPI1)																	■							
MISO (SPI1)																		■						
MOSI (SPI1)																			■					
NSS* (SPI1)																				■				
(*4-Wire SPI Only)																								
SCK (SPI0)	■																							
MISO (SPI0)		■																						
MOSI (SPI0)					■			■																
NSS* (SPI0)						■			■															
(*4-Wire SPI Only)																								
SDA	■				■	■	■	■	■	■	■		■	■										
SCL		■			■	■	■	■	■	■	■		■	■	■									
CP0	■	■	■	■	■	■	■	■	■	■	■	■	■	■	■	■	■	■	■	■	■	■	■	■
CP0A	■	■	■	■	■	■	■	■	■	■	■	■	■	■	■	■	■	■	■	■	■	■	■	■
CP1	■	■	■	■	■	■	■	■	■	■	■	■	■	■	■	■	■	■	■	■	■	■	■	■
CP1A	■	■	■	■	■	■	■	■	■	■	■	■	■	■	■	■	■	■	■	■	■	■	■	■
/SYSCLK	■	■	■	■	■	■	■	■	■	■	■	■	■	■	■	■	■	■	■	■	■	■	■	■
CEX0	■	■	■	■	■	■	■	■	■	■	■	■	■	■	■	■	■	■	■	■	■	■	■	■
CEX1	■	■	■	■	■	■	■	■	■	■	■	■	■	■	■	■	■	■	■	■	■	■	■	■
CEX2	■	■	■	■	■	■	■	■	■	■	■	■	■	■	■	■	■	■	■	■	■	■	■	■
CEX3	■	■	■	■	■	■	■	■	■	■	■	■	■	■	■	■	■	■	■	■	■	■	■	■
CEX4	■	■	■	■	■	■	■	■	■	■	■	■	■	■	■	■	■	■	■	■	■	■	■	■
CEX5	■	■	■	■	■	■	■	■	■	■	■	■	■	■	■	■	■	■	■	■	■	■	■	■
ECI	■	■	■	■	■	■	■	■	■	■	■	■	■	■	■	■	■	■	■	■	■	■	■	■
T0	■	■	■	■	■	■	■	■	■	■	■	■	■	■	■	■	■	■	■	■	■	■	■	■
T1	■	■	■	■	■	■	■	■	■	■	■	■	■	■	■	■	■	■	■	■	■	■	■	■
	0	0	0	0	0	0	0	0	0	0	0	0	0	0	0	0	0	0	0	0	0	0	0	0
	P0SKIP[0:7]								P1SKIP[0:7]								P2SKIP[0:7]							

Figure 27.4. Crossbar Priority Decoder with Crystal Pins Skipped

SFR Definition 27.1. XBR0: Port I/O Crossbar Register 0

Bit	7	6	5	4	3	2	1	0
Name	CP1AE	CP1E	CP0AE	CP0E	SYSCKE	SMB0E	SPI0E	URT0E
Type	R/W	R/W	R/W	R/W	R/W	R/W	R/W	R/W
Reset	0	0	0	0	0	0	0	0

SFR Page = 0x0 and 0xF; SFR Address = 0xE1

Bit	Name	Function
7	CP1AE	Comparator1 Asynchronous Output Enable. 0: Asynchronous CP1 output unavailable at Port pin. 1: Asynchronous CP1 output routed to Port pin.
6	CP1E	Comparator1 Output Enable. 0: CP1 output unavailable at Port pin. 1: CP1 output routed to Port pin.
5	CP0AE	Comparator0 Asynchronous Output Enable. 0: Asynchronous CP0 output unavailable at Port pin. 1: Asynchronous CP0 output routed to Port pin.
4	CP0E	Comparator0 Output Enable. 0: CP1 output unavailable at Port pin. 1: CP1 output routed to Port pin.
3	SYSCKE	SYSCCLK Output Enable. 0: $\overline{\text{SYSCCLK}}$ output unavailable at Port pin. 1: SYSCCLK output routed to Port pin.
2	SMB0E	SMBus I/O Enable. 0: SMBus I/O unavailable at Port pin. 1: SDA and SCL routed to Port pins.
1	SPI0E	SPI0 I/O Enable 0: SPI0 I/O unavailable at Port pin. 1: SCK, MISO, and MOSI (for SPI0) routed to Port pins. NSS (for SPI0) routed to Port pin only if SPI0 is configured to 4-wire mode.
0	URT0E	UART0 Output Enable. 0: UART I/O unavailable at Port pin. 1: TX0 and RX0 routed to Port pins P0.4 and P0.5.

Note: SPI0 can be assigned either 3 or 4 Port I/O pins.

Si102x/3x

SFR Definition 27.2. XBR1: Port I/O Crossbar Register 1

Bit	7	6	5	4	3	2	1	0
Name		SPI1E	T1E	T0E	ECIE	PCA0ME[2:0]		
Type	R/W	R/W	R/W	R/W	R/W	R/W		
Reset	0	0	0	0	0	0	0	0

SFR Page = 0x0 and 0xF; SFR Address = 0xE2

Bit	Name	Function
7	Unused	Read = 0b; Write = Don't Care.
6	SPI1E	SPI0 I/O Enable. 0: SPI1 I/O unavailable at Port pin. 1: SCK (for SPI1) routed to P2.0. MISO (for SPI1) routed to P2.1. MOSI (for SPI1) routed to P2.2. NSS (for SPI1) routed to P2.3 only if SPI1 is configured to 4-wire mode.
5	T1E	Timer1 Input Enable. 0: T1 input unavailable at Port pin. 1: T1 input routed to Port pin.
4	T0E	Timer0 Input Enable. 0: T0 input unavailable at Port pin. 1: T0 input routed to Port pin.
3	ECIE	PCA0 External Counter Input (ECI) Enable. 0: PCA0 external counter input unavailable at Port pin. 1: PCA0 external counter input routed to Port pin.
2:0	PCA0ME	PCA0 Module I/O Enable. 000: All PCA0 I/O unavailable at Port pin. 001: CEX0 routed to Port pin. 010: CEX0, CEX1 routed to Port pins. 011: CEX0, CEX1, CEX2 routed to Port pins. 100: CEX0, CEX1, CEX2, CEX3 routed to Port pins. 101: CEX0, CEX1, CEX2, CEX3, CEX4 routed to Port pins. 110: CEX0, CEX1, CEX2, CEX3, CEX4, CEX5 routed to Port pins. 111: Reserved.
Note: SPI1 can be assigned either 3 or 4 Port I/O pins.		

SFR Definition 27.3. XBR2: Port I/O Crossbar Register 2

Bit	7	6	5	4	3	2	1	0
Name	WEAKPUD	XBARE						
Type	R/W	R/W	R/W	R/W	R/W	R/W	R/W	R/W
Reset	0	0	0	0	0	0	0	0

SFR Page = 0x0 and 0xF; SFR Address = 0xE3

Bit	Name	Function
7	WEAKPUD	Port I/O Weak Pullup Disable 0: Weak Pullups enabled (except for Port I/O pins configured for analog mode).
6	XBARE	Crossbar Enable 0: Crossbar disabled. 1: Crossbar enabled.
5:0	Unused	Read = 000000b; Write = Don't Care.

Note: The Crossbar must be enabled (XBARE = 1) to use any Port pin as a digital output.

Si102x/3x

27.4. Port Match

Port match functionality allows system events to be triggered by a logic value change on P0 or P1. A software controlled value stored in the PnMAT registers specifies the expected or normal logic values of P0 and P1. A port mismatch event occurs if the logic levels of the port's input pins no longer match the software controlled value. This allows software to be notified if a certain change or pattern occurs on P0 or P1 input pins regardless of the XBRn settings.

The PnMASK registers can be used to individually select which P0 and P1 pins should be compared against the PnMAT registers. A port mismatch event is generated if (P0 & P0MASK) does not equal (PnMAT & P0MASK) or if (P1 & P1MASK) does not equal (PnMAT & P1MASK).

A Port mismatch event may be used to generate an interrupt or wake the device from a low power mode. See Section "17. Interrupt Handler" on page 238 and Section "19. Power Management" on page 264 for more details on interrupt and wake-up sources.

SFR Definition 27.4. P0MASK: Port0 Mask Register

Bit	7	6	5	4	3	2	1	0
Name	P0MASK[7:0]							
Type	R/W							
Reset	0	0	0	0	0	0	0	0

SFR Page= 0x0; SFR Address = 0xC7

Bit	Name	Function
7:0	P0MASK[7:0]	Port0 Mask Value. Selects the P0 pins to be compared with the corresponding bits in P0MAT. 0: P0.n pin pad logic value is ignored and cannot cause a Port Mismatch event. 1: P0.n pin pad logic value is compared to P0MAT.n.

SFR Definition 27.5. P0MAT: Port0 Match Register

Bit	7	6	5	4	3	2	1	0
Name	P0MAT[7:0]							
Type	R/W							
Reset	1	1	1	1	1	1	1	1

SFR Page= 0x0; SFR Address = 0xD7

Bit	Name	Function
7:0	P0MAT[7:0]	Port 0 Match Value. Match comparison value used on Port 0 for bits in P0MASK which are set to 1. 0: P0.n pin logic value is compared with logic LOW. 1: P0.n pin logic value is compared with logic HIGH.

SFR Definition 27.6. P1MASK: Port1 Mask Register

Bit	7	6	5	4	3	2	1	0
Name	P1MASK[7:0]							
Type	R/W							
Reset	0	0	0	0	0	0	0	0

SFR Page= 0x0; SFR Address = 0xBF

Bit	Name	Function
7:0	P1MASK[7:0]	Port 1 Mask Value. Selects P1 pins to be compared to the corresponding bits in P1MAT. 0: P1.n pin logic value is ignored and cannot cause a Port Mismatch event. 1: P1.n pin logic value is compared to P1MAT.n.
Note:		

SFR Definition 27.7. P1MAT: Port1 Match Register

Bit	7	6	5	4	3	2	1	0
Name	P1MAT[7:0]							
Type	R/W							
Reset	1	1	1	1	1	1	1	1

SFR Page = 0x0; SFR Address = 0xCF

Bit	Name	Function
7:0	P1MAT[7:0]	Port 1 Match Value. Match comparison value used on Port 1 for bits in P1MASK which are set to 1. 0: P1.n pin logic value is compared with logic LOW. 1: P1.n pin logic value is compared with logic HIGH.
Note:		

27.5. Special Function Registers for Accessing and Configuring Port I/O

All port I/O are accessed through corresponding special function registers (SFRs) that are both byte addressable and bit addressable. When writing to a port, the value written to the SFR is latched to maintain the output data value at each pin. When reading, the logic levels of the port's input pins are returned regardless of the XBRn settings (i.e., even when the pin is assigned to another signal by the crossbar, the port register can always read its corresponding port I/O pin). The exception to this is the execution of the read-modify-write instructions that target a port latch register as the destination. The read-modify-write instructions when operating on a port SFR are the following: ANL, ORL, XRL, JBC, CPL, INC, DEC, DJNZ and MOV, CLR or SETB, when the destination is an individual bit in a port SFR. For these instructions, the value of the latch register (not the pin) is read, modified, and written back to the SFR.

Each port has a corresponding PnSKIP register which allows its individual port pins to be assigned to digital functions or skipped by the crossbar. All port pins used for analog functions, GPIO, or dedicated digital functions such as the EMIF should have their PnSKIP bit set to 1.

The port input mode of the I/O pins is defined using the port Input Mode registers (PnMDIN). Each port cell can be configured for analog or digital I/O. This selection is required even for the digital resources selected in the XBRn registers, and is not automatic. The only exception to this is P2.7, which can only be used for digital I/O.

The output driver characteristics of the I/O pins are defined using the Port Output Mode registers (PnMDOUT). Each port output driver can be configured as either open drain or push-pull. This selection is required even for the digital resources selected in the XBRn registers, and is not automatic. The only exception to this is the SMBus (SDA, SCL) pins, which are configured as open-drain regardless of the PnMDOUT settings.

The drive strength of the output drivers are controlled by the Port Drive Strength (PnDRV) registers. The default is low drive strength. See Section "4. Electrical Characteristics" on page 50 for the difference in output drive strength between the two modes.

SFR Definition 27.8. P0: Port0

Bit	7	6	5	4	3	2	1	0
Name	P0[7:0]							
Type	R/W							
Reset	1	1	1	1	1	1	1	1

SFR Page = All Pages; SFR Address = 0x80; Bit-Addressable

Bit	Name	Description	Write	Read
7:0	P0[7:0]	Port 0 Data. Sets the port latch logic value or reads the port pin logic state in port cells configured for digital I/O.	0: Set output latch to logic LOW. 1: Set output latch to logic HIGH.	0: P0.n port pin is logic LOW. 1: P0.n port pin is logic HIGH.

SFR Definition 27.9. P0SKIP: Port0 Skip

Bit	7	6	5	4	3	2	1	0
Name	P0SKIP[7:0]							
Type	R/W							
Reset	0	0	0	0	0	0	0	0

SFR Page= 0x0; SFR Address = 0xD4

Bit	Name	Function
7:0	P0SKIP[7:0]	Port 0 Crossbar Skip Enable Bits. These bits select Port 0 pins to be skipped by the crossbar decoder. Port pins used for analog, special functions or GPIO should be skipped by the crossbar. 0: Corresponding P0.n pin is not skipped by the crossbar. 1: Corresponding P0.n pin is skipped by the crossbar.

Si102x/3x

SFR Definition 27.10. P0MDIN: Port0 Input Mode

Bit	7	6	5	4	3	2	1	0
Name	P0MDIN[7:0]							
Type	R/W							
Reset	1	1	1	1	1	1	1	1

SFR Page= 0x0; SFR Address = 0xF1

Bit	Name	Function
7:0	P0MDIN[7:0]	Analog Configuration Bits for P0.7–P0.0 (respectively). Port pins configured for analog mode have their weak pullup, and digital receiver disabled. The digital driver is not explicitly disabled. 0: Corresponding P0.n pin is configured for analog mode. 1: Corresponding P0.n pin is not configured for analog mode.

SFR Definition 27.11. P0MDOUT: Port0 Output Mode

Bit	7	6	5	4	3	2	1	0
Name	P0MDOUT[7:0]							
Type	R/W							
Reset	0	0	0	0	0	0	0	0

SFR Page = 0x0; SFR Address = 0xA4

Bit	Name	Function
7:0	P0MDOUT[7:0]	Output Configuration Bits for P0.7–P0.0 (respectively). These bits control the digital driver even when the corresponding bit in register P0MDIN is logic 0. 0: Corresponding P0.n output is open-drain. 1: Corresponding P0.n output is push-pull.

SFR Definition 27.12. P0DRV: Port0 Drive Strength

Bit	7	6	5	4	3	2	1	0
Name	P0DRV[7:0]							
Type	R/W							
Reset	0	0	0	0	0	0	0	0

SFR Page = 0xF; SFR Address = 0xA4

Bit	Name	Function
7:0	P0DRV[7:0]	Drive Strength Configuration Bits for P0.7–P0.0 (respectively). Configures digital I/O port cells to high or low output drive strength. 0: Corresponding P0.n output has low output drive strength. 1: Corresponding P0.n output has high output drive strength.

SFR Definition 27.13. P1: Port1

Bit	7	6	5	4	3	2	1	0
Name	P1[7:0]							
Type	R/W							
Reset	1	1	1	1	1	1	1	1

SFR Page = All Pages; SFR Address = 0x90; Bit-Addressable

Bit	Name	Description	Write	Read
7:0	P1[7:0]	Port 1 Data. Sets the port latch logic value or reads the port pin logic state in port cells configured for digital I/O.	0: Set output latch to logic LOW. 1: Set output latch to logic HIGH.	0: P1.n port pin is logic LOW. 1: P1.n port pin is logic HIGH.

Si102x/3x

SFR Definition 27.14. P1SKIP: Port1 Skip

Bit	7	6	5	4	3	2	1	0
Name	P1SKIP[7:0]							
Type	R/W							
Reset	0	0	0	0	0	0	0	0

SFR Page = 0x0; SFR Address = 0xD5

Bit	Name	Function
7:0	P1SKIP[7:0]	Port 1 Crossbar Skip Enable Bits. These bits select Port 1 pins to be skipped by the crossbar decoder. Port pins used for analog, special functions or GPIO should be skipped by the crossbar. 0: Corresponding P1.n pin is not skipped by the crossbar. 1: Corresponding P1.n pin is skipped by the crossbar.

SFR Definition 27.15. P1MDIN: Port1 Input Mode

Bit	7	6	5	4	3	2	1	0
Name	P1MDIN[7:0]							
Type	R/W							
Reset	1	1	1	1	1	1	1	1

SFR Page = 0x0; SFR Address = 0xF2

Bit	Name	Function
7:0	P1MDIN[7:0]	Analog Configuration Bits for P1.7–P1.0 (respectively). Port pins configured for analog mode have their weak pullup and digital receiver disabled. The digital driver is not explicitly disabled. 0: Corresponding P1.n pin is configured for analog mode. 1: Corresponding P1.n pin is not configured for analog mode.

SFR Definition 27.16. P1MDOUT: Port1 Output Mode

Bit	7	6	5	4	3	2	1	0
Name	P1MDOUT[7:0]							
Type	R/W							
Reset	0	0	0	0	0	0	0	0

SFR Page = 0x0; SFR Address = 0xA5

Bit	Name	Function
7:0	P1MDOUT[7:0]	Output Configuration Bits for P1.7–P1.0 (respectively). These bits control the digital driver even when the corresponding bit in register P1MDIN is logic 0. 0: Corresponding P1.n output is open-drain. 1: Corresponding P1.n output is push-pull.

SFR Definition 27.17. P1DRV: Port1 Drive Strength

Bit	7	6	5	4	3	2	1	0
Name	P1DRV[7:0]							
Type	R/W							
Reset	0	0	0	0	0	0	0	0

SFR Page = 0xF; SFR Address = 0xA5

Bit	Name	Function
7:0	P1DRV[7:0]	Drive Strength Configuration Bits for P1.7–P1.0 (respectively). Configures digital I/O port cells to high or low output drive strength. 0: Corresponding P1.n output has low output drive strength. 1: Corresponding P1.n output has high output drive strength.

Si102x/3x

SFR Definition 27.18. P2: Port2

Bit	7	6	5	4	3	2	1	0
Name	P2[7:0]							
Type	R/W							
Reset	1	1	1	1	1	1	1	1

SFR Page = All Pages; SFR Address = 0xA0; Bit-Addressable

Bit	Name	Description	Read	Write
7:0	P2[7:0]	Port 2 Data. Sets the port latch logic value or reads the port pin logic state in port cells configured for digital I/O.	0: Set output latch to logic LOW. 1: Set output latch to logic HIGH.	0: P2.n port pin is logic LOW. 1: P2.n port pin is logic HIGH.

SFR Definition 27.19. P2SKIP: Port2 Skip

Bit	7	6	5	4	3	2	1	0
Name	P2SKIP[7:0]							
Type	R/W							
Reset	0	0	0	0	0	0	0	0

SFR Page = 0x0; SFR Address = 0xD6

Bit	Name	Description	Read	Write
7:0	P2SKIP[7:0]	Port 1 Crossbar Skip Enable Bits. These bits select Port 2 pins to be skipped by the crossbar decoder. Port pins used for analog, special functions or GPIO should be skipped by the crossbar. 0: Corresponding P2.n pin is not skipped by the crossbar. 1: Corresponding P2.n pin is skipped by the crossbar.		

SFR Definition 27.20. P2MDIN: Port2 Input Mode

Bit	7	6	5	4	3	2	1	0
Name	P2MDIN[6:0]							
Type	R/W							
Reset	1	1	1	1	1	1	1	1

SFR Page = 0x0; SFR Address = 0xF3

Bit	Name	Function
7	Reserved	Read = 1b; Must Write 1b.
6:0	P2MDIN[6:0]	Analog Configuration Bits for P2.6–P2.0 (respectively). Port pins configured for analog mode have their weak pullup and digital receiver disabled. The digital driver is not explicitly disabled. 0: Corresponding P2.n pin is configured for analog mode. 1: Corresponding P2.n pin is not configured for analog mode.

SFR Definition 27.21. P2MDOUT: Port2 Output Mode

Bit	7	6	5	4	3	2	1	0
Name	P2MDOUT[7:0]							
Type	R/W							
Reset	0	0	0	0	0	0	0	0

SFR Page = 0x0; SFR Address = 0xA6

Bit	Name	Function
7:0	P2MDOUT[7:0]	Output Configuration Bits for P2.7–P2.0 (respectively). These bits control the digital driver even when the corresponding bit in register P2MDIN is logic 0. 0: Corresponding P2.n output is open-drain. 1: Corresponding P2.n output is push-pull.

Si102x/3x

SFR Definition 27.22. P2DRV: Port2 Drive Strength

Bit	7	6	5	4	3	2	1	0
Name	P2DRV[7:0]							
Type	R/W							
Reset	0	0	0	0	0	0	0	0

SFR Page = 0x0F; SFR Address = 0xA6

Bit	Name	Function
7:0	P2DRV[7:0]	Drive Strength Configuration Bits for P2.7–P2.0 (respectively). Configures digital I/O port cells to high or low output drive strength. 0: Corresponding P2.n output has low output drive strength. 1: Corresponding P2.n output has high output drive strength.

SFR Definition 27.23. P3: Port3

Bit	7	6	5	4	3	2	1	0
Name	P3[7:0]							
Type	R/W							
Reset	1	1	1	1	1	1	1	1

SFR Page = All Pages; SFR Address = 0xB0; Bit-Addressable

Bit	Name	Description	Read	Write
7:0	P3[7:0]	Port 3 Data. Sets the port latch logic value or reads the port pin logic state in port cells configured for digital I/O.	0: Set output latch to logic LOW. 1: Set output latch to logic HIGH.	0: P3.n port pin is logic LOW. 1: P3.n port pin is logic HIGH.

SFR Definition 27.24. P3MDIN: Port3 Input Mode

Bit	7	6	5	4	3	2	1	0
Name	P3MDIN[7:0]							
Type	R/W							
Reset	1	1	1	1	1	1	1	1

SFR Page = 0xF; SFR Address = 0xF1

Bit	Name	Function
7:0	P3MDIN[7:0]	Analog Configuration Bits for P3.7–P3.0 (respectively). Port pins configured for analog mode have their weak pullup and digital receiver disabled. The digital driver is not explicitly disabled. 0: Corresponding P3.n pin is configured for analog mode. 1: Corresponding P3.n pin is not configured for analog mode.

SFR Definition 27.25. P3MDOUT: Port3 Output Mode

Bit	7	6	5	4	3	2	1	0
Name	P3MDOUT[7:0]							
Type	R/W							
Reset	0	0	0	0	0	0	0	0

SFR Page = 0xF; SFR Address = 0xB1

Bit	Name	Function
7:0	P3MDOUT[7:0]	Output Configuration Bits for P3.7–P3.0 (respectively). These bits control the digital driver even when the corresponding bit in register P3MDIN is logic 0. 0: Corresponding P3.n output is open-drain. 1: Corresponding P3.n output is push-pull.

Si102x/3x

SFR Definition 27.26. P3DRV: Port3 Drive Strength

Bit	7	6	5	4	3	2	1	0
Name	P3DRV[7:0]							
Type	R/W							
Reset	0	0	0	0	0	0	0	0

SFR Page = 0xF; SFR Address = 0xA1

Bit	Name	Function
7:0	P3DRV[7:0]	Drive Strength Configuration Bits for P3.7–P3.0 (respectively). Configures digital I/O port cells to high or low output drive strength. 0: Corresponding P3.n output has low output drive strength. 1: Corresponding P3.n output has high output drive strength.

SFR Definition 27.27. P4: Port4

Bit	7	6	5	4	3	2	1	0
Name	P4[7:0]							
Type	R/W							
Reset	1	1	1	1	1	1	1	1

SFR Page = 0xF; SFR Address = 0xD9

Bit	Name	Description	Read	Write
7:0	P4[7:0]	Port 4 Data. Sets the port latch logic value or reads the port pin logic state in port cells configured for digital I/O.	0: Set output latch to logic LOW. 1: Set output latch to logic HIGH.	0: P4.n port pin is logic LOW. 1: P4.n port pin is logic HIGH.

SFR Definition 27.28. P4MDIN: Port4 Input Mode

Bit	7	6	5	4	3	2	1	0
Name	P4MDIN[7:0]							
Type	R/W							
Reset	1	1	1	1	1	1	1	1

SFR Page = 0xF; SFR Address = 0xF2

Bit	Name	Function
7:0	P4MDIN[7:0]	Analog Configuration Bits for P4.7–P4.0 (respectively). Port pins configured for analog mode have their weak pullup and digital receiver disabled. The digital driver is not explicitly disabled. 0: Corresponding P4.n pin is configured for analog mode. 1: Corresponding P4.n pin is not configured for analog mode.

SFR Definition 27.29. P4MDOUT: Port4 Output Mode

Bit	7	6	5	4	3	2	1	0
Name	P4MDOUT[7:0]							
Type	R/W							
Reset	0	0	0	0	0	0	0	0

SFR Page = 0xF; SFR Address = 0xF9

Bit	Name	Function
7:0	P4MDOUT[7:0]	Output Configuration Bits for P4.7–P4.0 (respectively). These bits control the digital driver even when the corresponding bit in register P4MDIN is logic 0. 0: Corresponding P4.n output is open-drain. 1: Corresponding P4.n output is push-pull.

Si102x/3x

SFR Definition 27.30. P4DRV: Port4 Drive Strength

Bit	7	6	5	4	3	2	1	0
Name	P4DRV[7:0]							
Type	R/W							
Reset	0	0	0	0	0	0	0	0

SFR Page = 0xF; SFR Address = 0xA2

Bit	Name	Function
7:0	P4DRV[7:0]	Drive Strength Configuration Bits for P4.7–P4.0 (respectively). Configures digital I/O port cells to high or low output drive strength. 0: Corresponding P4.n output has low output drive strength. 1: Corresponding P4.n output has high output drive strength.

SFR Definition 27.31. P5: Port5

Bit	7	6	5	4	3	2	1	0
Name	P5[7:0]							
Type	R/W							
Reset	1	1	1	1	1	1	1	1

SFR Page = 0xF; SFR Address = 0xDA

Bit	Name	Description	Read	Write
7:0	P5[7:0]	Port 5 Data. Sets the port latch logic value or reads the port pin logic state in port cells configured for digital I/O.	0: Set output latch to logic LOW. 1: Set output latch to logic HIGH.	0: P5.n port pin is logic LOW. 1: P5.n port pin is logic HIGH.

SFR Definition 27.32. P5MDIN: Port5 Input Mode

Bit	7	6	5	4	3	2	1	0
Name	P5MDIN[7:0]							
Type	R/W							
Reset	1	1	1	1	1	1	1	1

SFR Page = 0xF; SFR Address = 0xF3

Bit	Name	Function
7:0	P5MDIN[7:0]	Analog Configuration Bits for P5.7–P5.0 (respectively). Port pins configured for analog mode have their weak pullup and digital receiver disabled. The digital driver is not explicitly disabled. 0: Corresponding P5.n pin is configured for analog mode. 1: Corresponding P5.n pin is not configured for analog mode.
Note:		

SFR Definition 27.33. P5MDOUT: Port5 Output Mode

Bit	7	6	5	4	3	2	1	0
Name	P5MDOUT[7:0]							
Type	R/W							
Reset	0	0	0	0	0	0	0	0

SFR Page = 0xF; SFR Address = 0xFA

Bit	Name	Function
7:0	P5MDOUT[7:0]	Output Configuration Bits for P5.7–P5.0 (respectively). These bits control the digital driver even when the corresponding bit in register P5MDIN is logic 0. 0: Corresponding P5.n output is open-drain. 1: Corresponding P5.n output is push-pull.
Note:		

Si102x/3x

SFR Definition 27.34. P5DRV: Port5 Drive Strength

Bit	7	6	5	4	3	2	1	0
Name	P5DRV[7:0]							
Type	R/W							
Reset	0	0	0	0	0	0	0	0

SFR Page = 0xF; SFR Address = 0xA3

Bit	Name	Function
7:0	P5DRV[7:0]	Drive Strength Configuration Bits for P5.7–P5.0 (respectively). Configures digital I/O port cells to high or low output drive strength. 0: Corresponding P5.n output has low output drive strength. 1: Corresponding P5.n output has high output drive strength.

SFR Definition 27.35. P6: Port6

Bit	7	6	5	4	3	2	1	0
Name	P6[7:0]							
Type	R/W							
Reset	1	1	1	1	1	1	1	1

SFR Page = 0xF; SFR Address = 0xDB

Bit	Name	Description	Read	Write
7:0	P6[7:0]	Port 6 Data. Sets the port latch logic value or reads the port pin logic state in port cells configured for digital I/O.	0: Set output latch to logic LOW. 1: Set output latch to logic HIGH.	0: P6.n port pin is logic LOW. 1: P6.n port pin is logic HIGH.

SFR Definition 27.36. P6MDIN: Port6 Input Mode

Bit	7	6	5	4	3	2	1	0
Name	P6MDIN[7:0]							
Type	R/W							
Reset	1	1	1	1	1	1	1	1

SFR Page = 0xF; SFR Address = 0xF4

Bit	Name	Function
7:0	P6MDIN[7:0]	Analog Configuration Bits for P6.7–P6.0 (respectively). Port pins configured for analog mode have their weak pullup and digital receiver disabled. The digital driver is not explicitly disabled. 0: Corresponding P6.n pin is configured for analog mode. 1: Corresponding P6.n pin is not configured for analog mode.

SFR Definition 27.37. P6MDOUT: Port6 Output Mode

Bit	7	6	5	4	3	2	1	0
Name	P6MDOUT[7:0]							
Type	R/W							
Reset	0	0	0	0	0	0	0	0

SFR Page = 0xF; SFR Address = 0xFB

Bit	Name	Function
7:0	P6MDOUT[7:0]	Output Configuration Bits for P6.7–P6.0 (respectively). These bits control the digital driver even when the corresponding bit in register P6MDIN is logic 0. 0: Corresponding P6.n output is open-drain. 1: Corresponding P6.n output is push-pull.

Si102x/3x

SFR Definition 27.38. P6DRV: Port6 Drive Strength

Bit	7	6	5	4	3	2	1	0
Name	P6DRV[7:0]							
Type	R/W							
Reset	0	0	0	0	0	0	0	0

SFR Page = 0xF; SFR Address = 0xAA

Bit	Name	Function
7:0	P6DRV[7:0]	Drive Strength Configuration Bits for P6.7–P6.0 (respectively). Configures digital I/O port cells to high or low output drive strength. 0: Corresponding P6.n output has low output drive strength. 1: Corresponding P6.n output has high output drive strength.

SFR Definition 27.39. P7: Port7

Bit	7	6	5	4	3	2	1	0
Name								P7.0
Type								R/W
Reset	1	1	1	1	1	1	1	1

SFR Page = 0xF; SFR Address = 0xDC

Bit	Name	Description	Read	Write
7:1	Unused	Read = 0000000b; Write = Don't Care.		
0	P7.0	Port 7 Data. Sets the port latch logic value or reads the port pin logic state in port cells configured for digital I/O.	0: Set output latch to logic LOW. 1: Set output latch to logic HIGH.	0: P7.0 port pin is logic LOW. 1: P7.0 port pin is logic HIGH.

SFR Definition 27.40. P7MDOUT: Port7 Output Mode

Bit	7	6	5	4	3	2	1	0
Name								P7MDOUT
Type								R/W
Reset	0	0	0	0	0	0	0	0

SFR Page = 0xF; SFR Address = 0xFC

Bit	Name	Function
7:1	Unused	Read = 0000000b; Write = Don't Care.
0	P7MDOUT.0	Output Configuration Bits for P7.0. These bits control the digital driver. 0: P7.0 output is open-drain. 1: P7.0 output is push-pull.

SFR Definition 27.41. P7DRV: Port7 Drive Strength

Bit	7	6	5	4	3	2	1	0
Name								P7DRV
Type								R/W
Reset	0	0	0	0	0	0	0	0

SFR Page = 0xF; SFR Address = 0xAB

Bit	Name	Function
7:1	Unused	Read = 0000000b; Write = Don't Care.
0	P7DRV.0	Drive Strength Configuration Bits for P7.0. Configures digital I/O port cells to high or low output drive strength. 0: P7.0 output has low output drive strength. 1: P7.0 output has high output drive strength.

28. SMBus

The SMBus I/O interface is a two-wire, bi-directional serial bus. The SMBus is compliant with the System Management Bus Specification Version 1.1 and compatible with the I²C serial bus. Reads and writes to the interface by the system controller are byte oriented with the SMBus interface autonomously controlling the serial transfer of the data. Data can be transferred at up to 1/20th of the system clock as a master or slave (this can be faster than allowed by the SMBus specification, depending on the system clock used). A method of extending the clock-low duration is available to accommodate devices with different speed capabilities on the same bus.

The SMBus interface may operate as a master and/or slave, and may function on a bus with multiple masters. The SMBus provides control of SDA (serial data), SCL (serial clock) generation and synchronization, arbitration logic, and START/STOP control and generation. The SMBus peripheral can be fully driven by software (i.e., software accepts/rejects slave addresses, and generates ACKs), or hardware slave address recognition and automatic ACK generation can be enabled to minimize software overhead. A block diagram of the SMBus peripheral and the associated SFRs is shown in Figure 28.1.

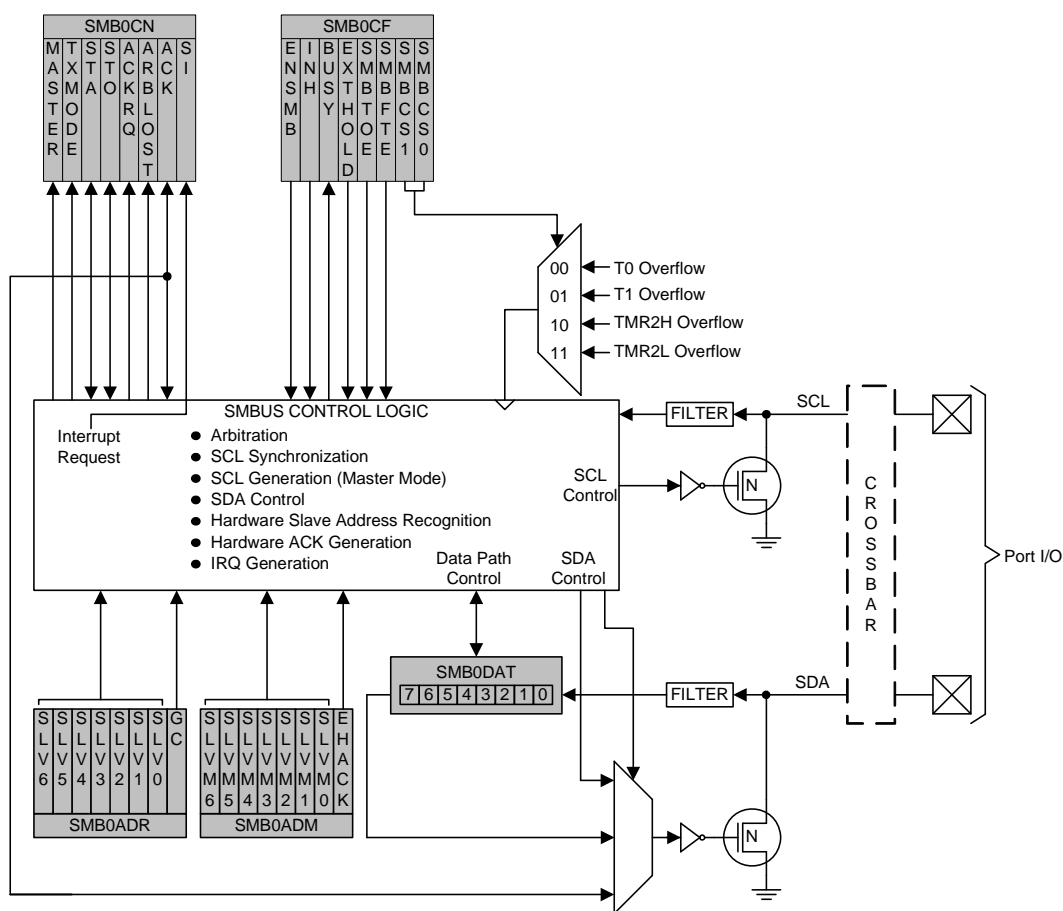

Figure 28.1. SMBus Block Diagram

28.1. Supporting Documents

It is assumed the reader is familiar with or has access to the following supporting documents:

1. The I²C-Bus and How to Use It (including specifications), Philips Semiconductor.
2. The I²C-Bus Specification—Version 2.0, Philips Semiconductor.
3. System Management Bus Specification—Version 1.1, SBS Implementers Forum.

28.2. SMBus Configuration

Figure 28.2 shows a typical SMBus configuration. The SMBus specification allows any recessive voltage between 3.0 V and 5.0 V; different devices on the bus may operate at different voltage levels. The bi-directional SCL (serial clock) and SDA (serial data) lines must be connected to a positive power supply voltage through a pullup resistor or similar circuit. Every device connected to the bus must have an open-drain or open-collector output for both the SCL and SDA lines, so that both are pulled high (recessive state) when the bus is free. The maximum number of devices on the bus is limited only by the requirement that the rise and fall times on the bus not exceed 300 ns and 1000 ns, respectively.

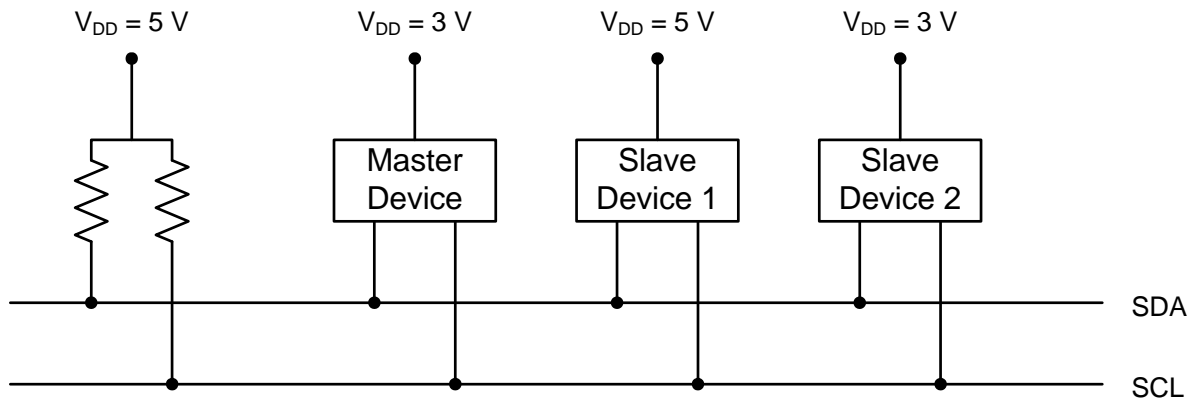

Figure 28.2. Typical SMBus Configuration

28.3. SMBus Operation

Two types of data transfers are possible: data transfers from a master transmitter to an addressed slave receiver (WRITE), and data transfers from an addressed slave transmitter to a master receiver (READ). The master device initiates both types of data transfers and provides the serial clock pulses on SCL. The SMBus interface may operate as a master or a slave, and multiple master devices on the same bus are supported. If two or more masters attempt to initiate a data transfer simultaneously, an arbitration scheme is employed with a single master always winning the arbitration. Note that it is not necessary to specify one device as the Master in a system; any device who transmits a START and a slave address becomes the master for the duration of that transfer.

A typical SMBus transaction consists of a START condition followed by an address byte (Bits7–1: 7-bit slave address; Bit0: R/W direction bit), one or more bytes of data, and a STOP condition. Bytes that are received (by a master or slave) are acknowledged (ACK) with a low SDA during a high SCL (see Figure 28.3). If the receiving device does not ACK, the transmitting device will read a NACK (not acknowledge), which is a high SDA during a high SCL.

The direction bit (R/W) occupies the least-significant bit position of the address byte. The direction bit is set to logic 1 to indicate a "READ" operation and cleared to logic 0 to indicate a "WRITE" operation.

Si102x/3x

All transactions are initiated by a master, with one or more addressed slave devices as the target. The master generates the START condition and then transmits the slave address and direction bit. If the transaction is a WRITE operation from the master to the slave, the master transmits the data a byte at a time waiting for an ACK from the slave at the end of each byte. For READ operations, the slave transmits the data waiting for an ACK from the master at the end of each byte. At the end of the data transfer, the master generates a STOP condition to terminate the transaction and free the bus. Figure 28.3 illustrates a typical SMBus transaction.

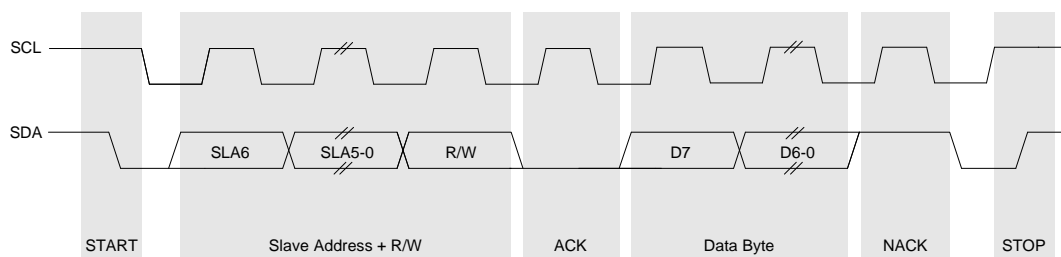

Figure 28.3. SMBus Transaction

28.3.1. Transmitter Vs. Receiver

On the SMBus communications interface, a device is the “transmitter” when it is sending an address or data byte to another device on the bus. A device is a “receiver” when an address or data byte is being sent to it from another device on the bus. The transmitter controls the SDA line during the address or data byte. After each byte of address or data information is sent by the transmitter, the receiver sends an ACK or NACK bit during the ACK phase of the transfer, during which time the receiver controls the SDA line.

28.3.2. Arbitration

A master may start a transfer only if the bus is free. The bus is free after a STOP condition or after the SCL and SDA lines remain high for a specified time (see Section “28.3.5. SCL High (SMBus Free) Timeout” on page 391). In the event that two or more devices attempt to begin a transfer at the same time, an arbitration scheme is employed to force one master to give up the bus. The master devices continue transmitting until one attempts a HIGH while the other transmits a LOW. Since the bus is open-drain, the bus will be pulled LOW. The master attempting the HIGH will detect a LOW SDA and lose the arbitration. The winning master continues its transmission without interruption; the losing master becomes a slave and receives the rest of the transfer if addressed. This arbitration scheme is non-destructive: one device always wins, and no data is lost.

28.3.3. Clock Low Extension

SMBus provides a clock synchronization mechanism, similar to I²C, which allows devices with different speed capabilities to coexist on the bus. A clock-low extension is used during a transfer in order to allow slower slave devices to communicate with faster masters. The slave may temporarily hold the SCL line LOW to extend the clock low period, effectively decreasing the serial clock frequency.

28.3.4. SCL Low Timeout

If the SCL line is held low by a slave device on the bus, no further communication is possible. Furthermore, the master cannot force the SCL line high to correct the error condition. To solve this problem, the SMBus protocol specifies that devices participating in a transfer must detect any clock cycle held low longer than 25 ms as a “timeout” condition. Devices that have detected the timeout condition must reset the communication no later than 10 ms after detecting the timeout condition.

When the SMBTOE bit in SMB0CF is set, Timer 3 is used to detect SCL low timeouts. Timer 3 is forced to reload when SCL is high, and allowed to count when SCL is low. With Timer 3 enabled and configured to

overflow after 25 ms (and SMBTOE set), the Timer 3 interrupt service routine can be used to reset (disable and re-enable) the SMBus in the event of an SCL low timeout.

28.3.5. SCL High (SMBus Free) Timeout

The SMBus specification stipulates that if the SCL and SDA lines remain high for more than 50 μ s, the bus is designated as free. When the SMBFTE bit in SMB0CF is set, the bus will be considered free if SCL and SDA remain high for more than 10 SMBus clock source periods (as defined by the timer configured for the SMBus clock source). If the SMBus is waiting to generate a Master START, the START will be generated following this timeout. A clock source is required for free timeout detection, even in a slave-only implementation.

28.4. Using the SMBus

The SMBus can operate in both Master and Slave modes. The interface provides timing and shifting control for serial transfers; higher level protocol is determined by user software. The SMBus interface provides the following application-independent features:

- Byte-wise serial data transfers
- Clock signal generation on SCL (Master Mode only) and SDA data synchronization
- Timeout/bus error recognition, as defined by the SMB0CF configuration register
- START/STOP timing, detection, and generation
- Bus arbitration
- Interrupt generation
- Status information
- Optional hardware recognition of slave address and automatic acknowledgement of address/data

SMBus interrupts are generated for each data byte or slave address that is transferred. When hardware acknowledgement is disabled, the point at which the interrupt is generated depends on whether the hardware is acting as a data transmitter or receiver. When a transmitter (i.e., sending address/data, receiving an ACK), this interrupt is generated after the ACK cycle so that software may read the received ACK value; when receiving data (i.e., receiving address/data, sending an ACK), this interrupt is generated before the ACK cycle so that software may define the outgoing ACK value. If hardware acknowledgement is enabled, these interrupts are always generated after the ACK cycle. See Section 28.5 for more details on transmission sequences.

Interrupts are also generated to indicate the beginning of a transfer when a master (START generated), or the end of a transfer when a slave (STOP detected). Software should read the SMB0CN (SMBus Control register) to find the cause of the SMBus interrupt. The SMB0CN register is described in Section 28.4.2; Table 28.5 provides a quick SMB0CN decoding reference.

28.4.1. SMBus Configuration Register

The SMBus Configuration register (SMB0CF) is used to enable the SMBus Master and/or Slave modes, select the SMBus clock source, and select the SMBus timing and timeout options. When the ENSMB bit is set, the SMBus is enabled for all master and slave events. Slave events may be disabled by setting the INH bit. With slave events inhibited, the SMBus interface will still monitor the SCL and SDA pins; however, the interface will NACK all received addresses and will not generate any slave interrupts. When the INH bit is set, all slave events will be inhibited following the next START (interrupts will continue for the duration of the current transfer).

Table 28.1. SMBus Clock Source Selection

SMBCS1	SMBCS0	SMBus Clock Source
0	0	Timer 0 Overflow
0	1	Timer 1 Overflow
1	0	Timer 2 High Byte Overflow
1	1	Timer 2 Low Byte Overflow

The SMBCS1–0 bits select the SMBus clock source, which is used only when operating as a master or when the Free Timeout detection is enabled. When operating as a master, overflows from the selected source determine the absolute minimum SCL low and high times as defined in Equation 28.1. The selected clock source may be shared by other peripherals so long as the timer is left running at all times. For example, Timer 1 overflows may generate the SMBus and UART baud rates simultaneously. Timer configuration is covered in Section “33. Timers” on page 491.

$$T_{HighMin} = T_{LowMin} = \frac{1}{f_{ClockSourceOverflow}}$$

Equation 28.1. Minimum SCL High and Low Times

The selected clock source should be configured to establish the minimum SCL High and Low times as per Equation 28.1. When the interface is operating as a master (and SCL is not driven or extended by any other devices on the bus), the typical SMBus bit rate is approximated by Equation 28.1.

$$BitRate = \frac{f_{ClockSourceOverflow}}{3}$$

Equation 28.2. Typical SMBus Bit Rate

Figure 28.4 shows the typical SCL generation described by Equation 28.2. Notice that T_{HIGH} is typically twice as large as T_{LOW} . The actual SCL output may vary due to other devices on the bus (SCL may be extended low by slower slave devices, or driven low by contending master devices). The bit rate when operating as a master will never exceed the limits defined by Equation 28.2.

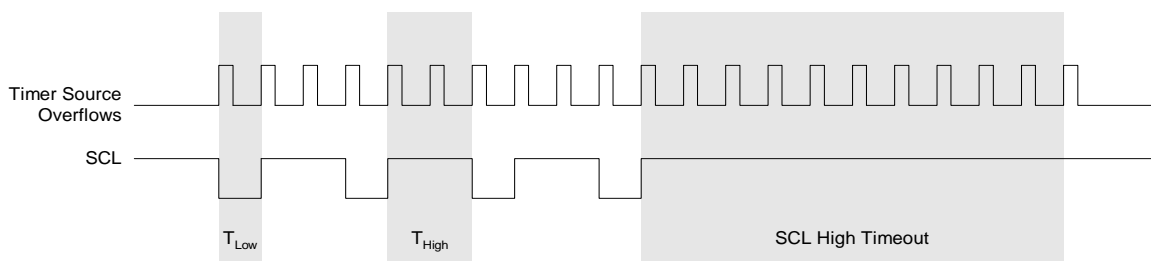

Figure 28.4. Typical SMBus SCL Generation

Setting the EXTHOLD bit extends the minimum setup and hold times for the SDA line. The minimum SDA setup time defines the absolute minimum time that SDA is stable before SCL transitions from low-to-high. The minimum SDA hold time defines the absolute minimum time that the current SDA value remains stable after SCL transitions from high-to-low. EXTHOLD should be set so that the minimum setup and hold times meet the SMBus Specification requirements of 250 ns and 300 ns, respectively. Table 28.2 shows the minimum setup and hold times for the two EXTHOLD settings. Setup and hold time extensions are typically necessary when SYSCLK is above 10 MHz.

Table 28.2. Minimum SDA Setup and Hold Times

EXTHOLD	Minimum SDA Setup Time	Minimum SDA Hold Time
0	$T_{low} - 4$ system clocks or 1 system clock + s/w delay*	3 system clocks
1	11 system clocks	12 system clocks
<p>*Note: Setup Time for ACK bit transmissions and the MSB of all data transfers. When using software acknowledgement, the s/w delay occurs between the time SMB0DAT or ACK is written and when SI is cleared. Note that if SI is cleared in the same write that defines the outgoing ACK value, s/w delay is zero.</p>		

With the SMBTOE bit set, Timer 3 should be configured to overflow after 25 ms in order to detect SCL low timeouts (see Section “28.3.4. SCL Low Timeout” on page 390). The SMBus interface will force Timer 3 to reload while SCL is high, and allow Timer 3 to count when SCL is low. The Timer 3 interrupt service routine should be used to reset SMBus communication by disabling and re-enabling the SMBus.

SMBus Free Timeout detection can be enabled by setting the SMBFTE bit. When this bit is set, the bus will be considered free if SDA and SCL remain high for more than 10 SMBus clock source periods (see Figure 28.4).

SFR Definition 28.1. SMB0CF: SMBus Clock/Configuration

Bit	7	6	5	4	3	2	1	0
Name	ENSMB	INH	BUSY	EXTHOLD	SMBTOE	SMBFTE	SMBCS[1:0]	
Type	R/W	R/W	R	R/W	R/W	R/W	R/W	
Reset	0	0	0	0	0	0	0	0

SFR Page = 0x0; SFR Address = 0xC1

Bit	Name	Function
7	ENSMB	SMBus Enable. This bit enables the SMBus interface when set to 1. When enabled, the interface constantly monitors the SDA and SCL pins.
6	INH	SMBus Slave Inhibit. When this bit is set to logic 1, the SMBus does not generate an interrupt when slave events occur. This effectively removes the SMBus slave from the bus. Master Mode interrupts are not affected.
5	BUSY	SMBus Busy Indicator. This bit is set to logic 1 by hardware when a transfer is in progress. It is cleared to logic 0 when a STOP or free-timeout is sensed.
4	EXTHOLD	SMBus Setup and Hold Time Extension Enable. This bit controls the SDA setup and hold times according to Table 28.2. 0: SDA Extended Setup and Hold Times disabled. 1: SDA Extended Setup and Hold Times enabled.
3	SMBTOE	SMBus SCL Timeout Detection Enable. This bit enables SCL low timeout detection. If set to logic 1, the SMBus forces Timer 3 to reload while SCL is high and allows Timer 3 to count when SCL goes low. If Timer 3 is configured to Split Mode, only the High Byte of the timer is held in reload while SCL is high. Timer 3 should be programmed to generate interrupts at 25 ms, and the Timer 3 interrupt service routine should reset SMBus communication.
2	SMBFTE	SMBus Free Timeout Detection Enable. When this bit is set to logic 1, the bus will be considered free if SCL and SDA remain high for more than 10 SMBus clock source periods.
1:0	SMBCS[1:0]	SMBus Clock Source Selection. These two bits select the SMBus clock source, which is used to generate the SMBus bit rate. The selected device should be configured according to Equation 28.1. 00: Timer 0 Overflow 01: Timer 1 Overflow 10: Timer 2 High Byte Overflow 11: Timer 2 Low Byte Overflow

28.4.2. SMB0CN Control Register

SMB0CN is used to control the interface and to provide status information (see SFR Definition 28.2). The higher four bits of SMB0CN (MASTER, TXMODE, STA, and STO) form a status vector that can be used to jump to service routines. MASTER indicates whether a device is the master or slave during the current transfer. TXMODE indicates whether the device is transmitting or receiving data for the current byte.

STA and STO indicate that a START and/or STOP has been detected or generated since the last SMBus interrupt. STA and STO are also used to generate START and STOP conditions when operating as a master. Writing a 1 to STA will cause the SMBus interface to enter Master Mode and generate a START when the bus becomes free (STA is not cleared by hardware after the START is generated). Writing a 1 to STO while in Master Mode will cause the interface to generate a STOP and end the current transfer after the next ACK cycle. If STO and STA are both set (while in Master Mode), a STOP followed by a START will be generated.

The ARBLOST bit indicates that the interface has lost an arbitration. This may occur anytime the interface is transmitting (master or slave). A lost arbitration while operating as a slave indicates a bus error condition. ARBLOST is cleared by hardware each time SI is cleared.

The SI bit (SMBus Interrupt Flag) is set at the beginning and end of each transfer, after each byte frame, or when an arbitration is lost; see Table 28.3 for more details.

Important Note About the SI Bit: The SMBus interface is stalled while SI is set; thus SCL is held low, and the bus is stalled until software clears SI.

28.4.2.1. Software ACK Generation

When the EHACK bit in register SMB0ADM is cleared to 0, the firmware on the device must detect incoming slave addresses and ACK or NACK the slave address and incoming data bytes. As a receiver, writing the ACK bit defines the outgoing ACK value; as a transmitter, reading the ACK bit indicates the value received during the last ACK cycle. ACKRQ is set each time a byte is received, indicating that an outgoing ACK value is needed. When ACKRQ is set, software should write the desired outgoing value to the ACK bit before clearing SI. A NACK will be generated if software does not write the ACK bit before clearing SI. SDA will reflect the defined ACK value immediately following a write to the ACK bit; however SCL will remain low until SI is cleared. If a received slave address is not acknowledged, further slave events will be ignored until the next START is detected.

28.4.2.2. Hardware ACK Generation

When the EHACK bit in register SMB0ADM is set to 1, automatic slave address recognition and ACK generation is enabled. More detail about automatic slave address recognition can be found in Section 28.4.3. As a receiver, the value currently specified by the ACK bit will be automatically sent on the bus during the ACK cycle of an incoming data byte. As a transmitter, reading the ACK bit indicates the value received on the last ACK cycle. The ACKRQ bit is not used when hardware ACK generation is enabled. If a received slave address is NACKed by hardware, further slave events will be ignored until the next START is detected, and no interrupt will be generated.

Table 28.3 lists all sources for hardware changes to the SMB0CN bits. Refer to Table 28.5 for SMBus status decoding using the SMB0CN register.

Si102x/3x

SFR Definition 28.2. SMB0CN: SMBus Control

Bit	7	6	5	4	3	2	1	0
Name	MASTER	TXMODE	STA	STO	ACKRQ	ARBLOST	ACK	SI
Type	R	R	R/W	R/W	R	R	R/W	R/W
Reset	0	0	0	0	0	0	0	0

SFR Page = All Pages; SFR Address = 0xC0; Bit-Addressable

Bit	Name	Description	Read	Write
7	MASTER	SMBus Master/Slave Indicator. This read-only bit indicates when the SMBus is operating as a master.	0: SMBus operating in slave mode. 1: SMBus operating in master mode.	N/A
6	TXMODE	SMBus Transmit Mode Indicator. This read-only bit indicates when the SMBus is operating as a transmitter.	0: SMBus in Receiver Mode. 1: SMBus in Transmitter Mode.	N/A
5	STA	SMBus Start Flag.	0: No Start or repeated Start detected. 1: Start or repeated Start detected.	0: No Start generated. 1: When Configured as a Master, initiates a START or repeated START.
4	STO	SMBus Stop Flag.	0: No Stop condition detected. 1: Stop condition detected (if in Slave Mode) or pending (if in Master Mode).	0: No STOP condition is transmitted. 1: When configured as a Master, causes a STOP condition to be transmitted after the next ACK cycle. Cleared by Hardware.
3	ACKRQ	SMBus Acknowledge Request.	0: No Ack requested 1: ACK requested	N/A
2	ARBLOST	SMBus Arbitration Lost Indicator.	0: No arbitration error. 1: Arbitration Lost	N/A
1	ACK	SMBus Acknowledge.	0: NACK received. 1: ACK received.	0: Send NACK 1: Send ACK
0	SI	SMBus Interrupt Flag. This bit is set by hardware under the conditions listed in Table 15.3. SI must be cleared by software. While SI is set, SCL is held low and the SMBus is stalled.	0: No interrupt pending 1: Interrupt Pending	0: Clear interrupt, and initiate next state machine event. 1: Force interrupt.

Table 28.3. Sources for Hardware Changes to SMB0CN

Bit	Set by Hardware When:	Cleared by Hardware When:
MASTER	<ul style="list-style-type: none"> • A START is generated. 	<ul style="list-style-type: none"> • A STOP is generated. • Arbitration is lost.
TXMODE	<ul style="list-style-type: none"> • START is generated. • SMB0DAT is written before the start of an SMBus frame. 	<ul style="list-style-type: none"> • A START is detected. • Arbitration is lost. • SMB0DAT is not written before the start of an SMBus frame.
STA	<ul style="list-style-type: none"> • A START followed by an address byte is received. 	<ul style="list-style-type: none"> • Must be cleared by software.
STO	<ul style="list-style-type: none"> • A STOP is detected while addressed as a slave. • Arbitration is lost due to a detected STOP. 	<ul style="list-style-type: none"> • A pending STOP is generated.
ACKRQ	<ul style="list-style-type: none"> • A byte has been received and an ACK response value is needed (only when hardware ACK is not enabled). 	<ul style="list-style-type: none"> • After each ACK cycle.
ARBLOST	<ul style="list-style-type: none"> • A repeated START is detected as a MASTER when STA is low (unwanted repeated START). • SCL is sensed low while attempting to generate a STOP or repeated START condition. • SDA is sensed low while transmitting a 1 (excluding ACK bits). 	<ul style="list-style-type: none"> • Each time SI is cleared.
ACK	<ul style="list-style-type: none"> • The incoming ACK value is low (ACKNOWLEDGE). 	<ul style="list-style-type: none"> • The incoming ACK value is high (NOT ACKNOWLEDGE).
SI	<ul style="list-style-type: none"> • A START has been generated. • Lost arbitration. • A byte has been transmitted and an ACK/NACK received. • A byte has been received. • A START or repeated START followed by a slave address + R/W has been received. • A STOP has been received. 	<ul style="list-style-type: none"> • Must be cleared by software.

28.4.3. Hardware Slave Address Recognition

The SMBus hardware has the capability to automatically recognize incoming slave addresses and send an ACK without software intervention. Automatic slave address recognition is enabled by setting the EHACK bit in register SMB0ADM to 1. This will enable both automatic slave address recognition and automatic hardware ACK generation for received bytes (as a master or slave). More detail on automatic hardware ACK generation can be found in Section 28.4.2.2.

The registers used to define which address(es) are recognized by the hardware are the SMBus Slave Address register (SFR Definition 28.3) and the SMBus Slave Address Mask register (SFR Definition 28.4). A single address or range of addresses (including the General Call Address 0x00) can be specified using these two registers. The most-significant seven bits of the two registers are used to define which addresses will be ACKed. A 1 in bit positions of the slave address mask SLVM[6:0] enable a comparison between the received slave address and the hardware's slave address SLV[6:0] for those bits. A 0 in a bit of the slave address mask means that bit will be treated as a "don't care" for comparison purposes. In this case, either a 1 or a 0 value are acceptable on the incoming slave address. Additionally, if the GC bit in register SMB0ADR is set to 1, hardware will recognize the General Call Address (0x00). Table 28.4 shows some example parameter settings and the slave addresses that will be recognized by hardware under those conditions.

Si102x/3x

Table 28.4. Hardware Address Recognition Examples (EHACK = 1)

Hardware Slave Address SLV[6:0]	Slave Address Mask SLVM[6:0]	GC bit	Slave Addresses Recognized by Hardware
0x34	0x7F	0	0x34
0x34	0x7F	1	0x34, 0x00 (General Call)
0x34	0x7E	0	0x34, 0x35
0x34	0x7E	1	0x34, 0x35, 0x00 (General Call)
0x70	0x73	0	0x70, 0x74, 0x78, 0x7C

SFR Definition 28.3. SMB0ADR: SMBus Slave Address

Bit	7	6	5	4	3	2	1	0
Name	SLV[6:0]							GC
Type	R/W							R/W
Reset	0	0	0	0	0	0	0	0

SFR Page = 0x0; SFR Address = 0xF4

Bit	Name	Function
7:1	SLV[6:0]	<p>SMBus Hardware Slave Address.</p> <p>Defines the SMBus Slave Address(es) for automatic hardware acknowledgement. Only address bits which have a 1 in the corresponding bit position in SLVM[6:0] are checked against the incoming address. This allows multiple addresses to be recognized.</p>
0	GC	<p>General Call Address Enable.</p> <p>When hardware address recognition is enabled (EHACK = 1), this bit will determine whether the General Call Address (0x00) is also recognized by hardware.</p> <p>0: General Call Address is ignored. 1: General Call Address is recognized.</p>

SFR Definition 28.4. SMB0ADM: SMBus Slave Address Mask

Bit	7	6	5	4	3	2	1	0
Name	SLVM[6:0]							EHACK
Type	R/W							R/W
Reset	1	1	1	1	1	1	1	0

SFR Page = 0x0; SFR Address = 0xF5

Bit	Name	Function
7:1	SLVM[6:0]	SMBus Slave Address Mask. Defines which bits of register SMB0ADR are compared with an incoming address byte, and which bits are ignored. Any bit set to 1 in SLVM[6:0] enables comparisons with the corresponding bit in SLV[6:0]. Bits set to 0 are ignored (can be either 0 or 1 in the incoming address).
0	EHACK	Hardware Acknowledge Enable. Enables hardware acknowledgement of slave address and received data bytes. 0: Firmware must manually acknowledge all incoming address and data bytes. 1: Automatic Slave Address Recognition and Hardware Acknowledge is Enabled.

Si102x/3x

28.4.4. Data Register

The SMBus Data register SMB0DAT holds a byte of serial data to be transmitted or one that has just been received. Software may safely read or write to the data register when the SI flag is set. Software should not attempt to access the SMB0DAT register when the SMBus is enabled and the SI flag is cleared to logic 0, as the interface may be in the process of shifting a byte of data into or out of the register.

Data in SMB0DAT is always shifted out MSB first. After a byte has been received, the first bit of received data is located at the MSB of SMB0DAT. While data is being shifted out, data on the bus is simultaneously being shifted in. SMB0DAT always contains the last data byte present on the bus. In the event of lost arbitration, the transition from master transmitter to slave receiver is made with the correct data or address in SMB0DAT.

SFR Definition 28.5. SMB0DAT: SMBus Data

Bit	7	6	5	4	3	2	1	0
Name	SMB0DAT[7:0]							
Type	R/W							
Reset	0	0	0	0	0	0	0	0

SFR Page = 0x0; SFR Address = 0xC2

Bit	Name	Function
7:0	SMB0DAT[7:0]	SMBus Data. The SMB0DAT register contains a byte of data to be transmitted on the SMBus serial interface or a byte that has just been received on the SMBus serial interface. The CPU can read from or write to this register whenever the SI serial interrupt flag (SMB0CN.0) is set to logic 1. The serial data in the register remains stable as long as the SI flag is set. When the SI flag is not set, the system may be in the process of shifting data in/out and the CPU should not attempt to access this register.

28.5. SMBus Transfer Modes

The SMBus interface may be configured to operate as master and/or slave. At any particular time, it will be operating in one of the following four modes: Master Transmitter, Master Receiver, Slave Transmitter, or Slave Receiver. The SMBus interface enters Master Mode any time a START is generated, and remains in Master Mode until it loses an arbitration or generates a STOP. An SMBus interrupt is generated at the end of all SMBus byte frames. Note that the position of the ACK interrupt when operating as a receiver depends on whether hardware ACK generation is enabled. As a receiver, the interrupt for an ACK occurs **before** the ACK with hardware ACK generation disabled, and **after** the ACK when hardware ACK generation is enabled. As a transmitter, interrupts occur **after** the ACK, regardless of whether hardware ACK generation is enabled or not.

28.5.1. Write Sequence (Master)

During a write sequence, an SMBus master writes data to a slave device. The master in this transfer will be a transmitter during the address byte, and a transmitter during all data bytes. The SMBus interface generates the START condition and transmits the first byte containing the address of the target slave and the data direction bit. In this case the data direction bit (R/W) will be logic 0 (WRITE). The master then transmits one or more bytes of serial data. After each byte is transmitted, an acknowledge bit is generated by the slave. The transfer is ended when the STO bit is set and a STOP is generated. Note that the interface will switch to Master Receiver Mode if SMB0DAT is not written following a Master Transmitter interrupt.

Figure 28.5 shows a typical master write sequence. Two transmit data bytes are shown, though any number of bytes may be transmitted. All “data byte transferred” interrupts occur **after** the ACK cycle in this mode, regardless of whether hardware ACK generation is enabled.

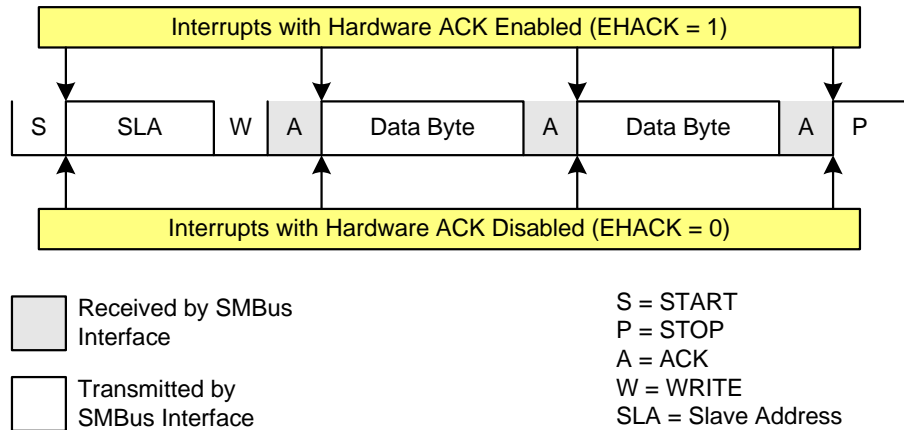

Figure 28.5. Typical Master Write Sequence

28.5.2. Read Sequence (Master)

During a read sequence, an SMBus master reads data from a slave device. The master in this transfer will be a transmitter during the address byte, and a receiver during all data bytes. The SMBus interface generates the START condition and transmits the first byte containing the address of the target slave and the data direction bit. In this case the data direction bit (R/W) will be logic 1 (READ). Serial data is then received from the slave on SDA while the SMBus outputs the serial clock. The slave transmits one or more bytes of serial data.

If hardware ACK generation is disabled, the ACKRQ is set to 1 and an interrupt is generated after each received byte. Software must write the ACK bit at that time to ACK or NACK the received byte.

With hardware ACK generation enabled, the SMBus hardware will automatically generate the ACK/NACK, and then post the interrupt. **It is important to note that the appropriate ACK or NACK value should be set up by the software prior to receiving the byte when hardware ACK generation is enabled.**

Writing a 1 to the ACK bit generates an ACK; writing a 0 generates a NACK. Software should write a 0 to the ACK bit for the last data transfer, to transmit a NACK. The interface exits Master Receiver Mode after the STO bit is set and a STOP is generated. The interface will switch to Master Transmitter Mode if SMBODAT is written while an active Master Receiver. Figure 28.6 shows a typical master read sequence. Two received data bytes are shown, though any number of bytes may be received. The “data byte transferred” interrupts occur at different places in the sequence, depending on whether hardware ACK generation is enabled. The interrupt occurs **before** the ACK with hardware ACK generation disabled, and **after** the ACK when hardware ACK generation is enabled.

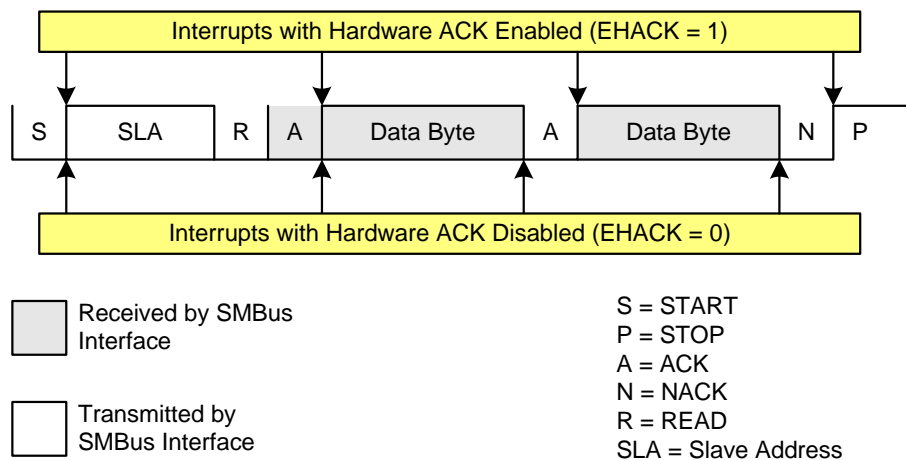

Figure 28.6. Typical Master Read Sequence

28.5.3. Write Sequence (Slave)

During a write sequence, an SMBus master writes data to a slave device. The slave in this transfer will be a receiver during the address byte, and a receiver during all data bytes. When slave events are enabled (INH = 0), the interface enters Slave Receiver Mode when a START followed by a slave address and direction bit (WRITE in this case) is received. If hardware ACK generation is disabled, upon entering Slave Receiver Mode, an interrupt is generated and the ACKRQ bit is set. The software must respond to the received slave address with an ACK, or ignore the received slave address with a NACK. If hardware ACK generation is enabled, the hardware will apply the ACK for a slave address which matches the criteria set up by SMB0ADR and SMB0ADM. The interrupt will occur after the ACK cycle.

If the received slave address is ignored (by software or hardware), slave interrupts will be inhibited until the next START is detected. If the received slave address is acknowledged, zero or more data bytes are received.

If hardware ACK generation is disabled, the ACKRQ is set to 1 and an interrupt is generated after each received byte. Software must write the ACK bit at that time to ACK or NACK the received byte.

With hardware ACK generation enabled, the SMBus hardware will automatically generate the ACK/NACK, and then post the interrupt. **The appropriate ACK or NACK value should be set up by the software prior to receiving the byte when hardware ACK generation is enabled.**

The interface exits Slave Receiver Mode after receiving a STOP. Note that the interface will switch to Slave Transmitter Mode if SMB0DAT is written while an active Slave Receiver. Figure 28.7 shows a typical slave write sequence. Two received data bytes are shown, though any number of bytes may be received. Notice that the 'data byte transferred' interrupts occur at different places in the sequence, depending on whether hardware ACK generation is enabled. The interrupt occurs **before** the ACK with hardware ACK generation disabled, and **after** the ACK when hardware ACK generation is enabled.

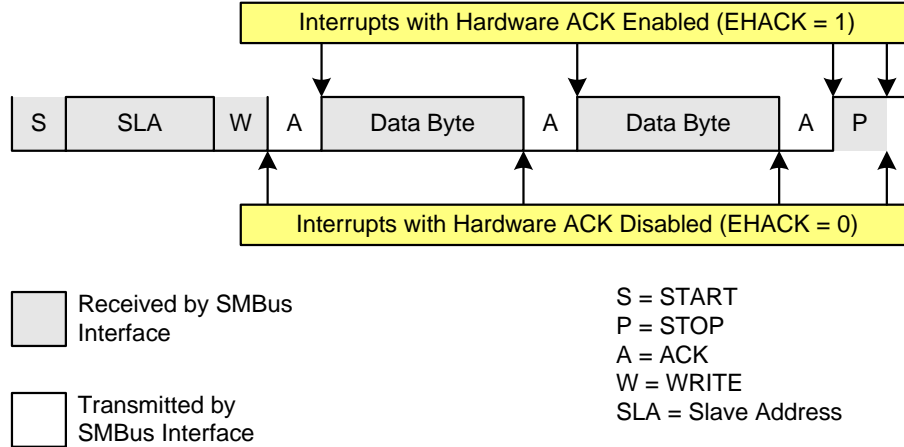

Figure 28.7. Typical Slave Write Sequence

28.5.4. Read Sequence (Slave)

During a read sequence, an SMBus master reads data from a slave device. The slave in this transfer will be a receiver during the address byte, and a transmitter during all data bytes. When slave events are enabled (INH = 0), the interface enters Slave Receiver Mode (to receive the slave address) when a START followed by a slave address and direction bit (READ in this case) is received. If hardware ACK generation is disabled, upon entering Slave Receiver Mode, an interrupt is generated and the ACKRQ bit is set. The software must respond to the received slave address with an ACK, or ignore the received slave address with a NACK. If hardware ACK generation is enabled, the hardware will apply the ACK for a slave address which matches the criteria set up by SMB0ADR and SMB0ADM. The interrupt will occur after the ACK cycle.

If the received slave address is ignored (by software or hardware), slave interrupts will be inhibited until the next START is detected. If the received slave address is acknowledged, zero or more data bytes are transmitted. If the received slave address is acknowledged, data should be written to SMB0DAT to be transmitted. The interface enters Slave Transmitter Mode, and transmits one or more bytes of data. After each byte is transmitted, the master sends an acknowledge bit; if the acknowledge bit is an ACK, SMB0DAT should be written with the next data byte. If the acknowledge bit is a NACK, SMB0DAT should not be written to before SI is cleared (an error condition may be generated if SMB0DAT is written following a received NACK while in Slave Transmitter Mode). The interface exits Slave Transmitter Mode after receiving a STOP. Note that the interface will switch to Slave Receiver Mode if SMB0DAT is not written following a Slave Transmitter interrupt. Figure 28.8 shows a typical slave read sequence. Two transmitted data bytes are shown, though any number of bytes may be transmitted. All of the “data byte transferred” interrupts occur **after** the ACK cycle in this mode, regardless of whether hardware ACK generation is enabled.

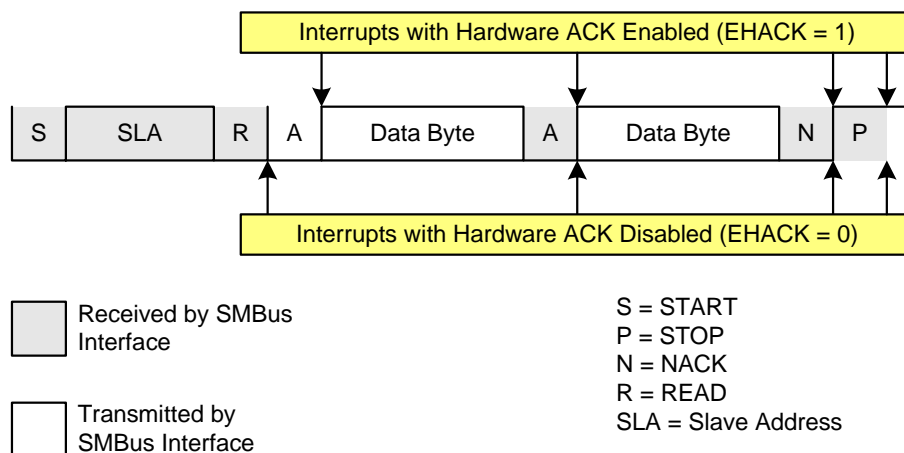

Figure 28.8. Typical Slave Read Sequence

28.6. SMBus Status Decoding

The current SMBus status can be easily decoded using the SMB0CN register. The appropriate actions to take in response to an SMBus event depend on whether hardware slave address recognition and ACK generation is enabled or disabled. Table 28.5 describes the typical actions when hardware slave address recognition and ACK generation is disabled. Table 28.6 describes the typical actions when hardware slave address recognition and ACK generation is enabled. In the tables, STATUS VECTOR refers to the four upper bits of SMB0CN: MASTER, TXMODE, STA, and STO. The shown response options are only the typical responses; application-specific procedures are allowed as long as they conform to the SMBus specification. Highlighted responses are allowed by hardware but do not conform to the SMBus specification.

Table 28.5. SMBus Status Decoding With Hardware ACK Generation Disabled (EHACK = 0)

Mode	Values Read			Current SMBus State	Typical Response Options	Values to Write			Next Status Vector Expected	
	Status Vector	ACKRQ	ARBLOST			ACK	STA	STO		ACK
Master Transmitter	1110	0	0	X	A master START was generated.	Load slave address + R/W into SMB0DAT.	0	0	X	1100
	1100	0	0	0	A master data or address byte was transmitted; NACK received.	Set STA to restart transfer.	1	0	X	1110
						Abort transfer.	0	1	X	-
	1100	0	0	1	A master data or address byte was transmitted; ACK received.	Load next data byte into SMB0DAT.	0	0	X	1100
						End transfer with STOP.	0	1	X	-
						End transfer with STOP and start another transfer.	1	1	X	-
						Send repeated START.	1	0	X	1110
					Switch to Master Receiver Mode (clear SI without writing new data to SMB0DAT).	0	0	X	1000	
Master Receiver	1000	1	0	X	A master data byte was received; ACK requested.	Acknowledge received byte; Read SMB0DAT.	0	0	1	1000
						Send NACK to indicate last byte, and send STOP.	0	1	0	-
						Send NACK to indicate last byte, and send STOP followed by START.	1	1	0	1110
						Send ACK followed by repeated START.	1	0	1	1110
						Send NACK to indicate last byte, and send repeated START.	1	0	0	1110
						Send ACK and switch to Master Transmitter Mode (write to SMB0DAT before clearing SI).	0	0	1	1100
						Send NACK and switch to Master Transmitter Mode (write to SMB0DAT before clearing SI).	0	0	0	1100

Si102x/3x

Table 28.5. SMBus Status Decoding With Hardware ACK Generation Disabled (EHACK = 0)

Mode	Values Read			Current SMBus State	Typical Response Options	Values to Write			Next Status Vector Expected	
	Status Vector	ACKRQ	ARBLOST			ACK	STA	STO		ACK
Slave Transmitter	0100	0	0	0	A slave byte was transmitted; NACK received.	No action required (expecting STOP condition).	0	0	X	0001
		0	0	1	A slave byte was transmitted; ACK received.	Load SMB0DAT with next data byte to transmit.	0	0	X	0100
		0	1	X	A Slave byte was transmitted; error detected.	No action required (expecting Master to end transfer).	0	0	X	0001
	0101	0	X	X	An illegal STOP or bus error was detected while a Slave Transmission was in progress.	Clear STO.	0	0	X	-
Slave Receiver	0010	1	0	X	A slave address + R/W was received; ACK requested.	If Write, Acknowledge received address	0	0	1	0000
						If Read, Load SMB0DAT with data byte; ACK received address	0	0	1	0100
						NACK received address.	0	0	0	-
	0010	1	1	X	Lost arbitration as master; slave address + R/W received; ACK requested.	If Write, Acknowledge received address	0	0	1	0000
						If Read, Load SMB0DAT with data byte; ACK received address	0	0	1	0100
						NACK received address.	0	0	0	-
						Reschedule failed transfer; NACK received address.	1	0	0	1110
	0001	0	0	X	A STOP was detected while addressed as a Slave Transmitter or Slave Receiver.	Clear STO.	0	0	X	-
						Lost arbitration while attempting a STOP.	No action required (transfer complete/aborted).	0	0	0
	0000	1	0	X	A slave byte was received; ACK requested.	Acknowledge received byte; Read SMB0DAT.	0	0	1	0000
NACK received byte.						0	0	0	-	
Bus Error Condition	0010	0	1	X	Lost arbitration while attempting a repeated START.	Abort failed transfer.	0	0	X	-
						Reschedule failed transfer.	1	0	X	1110
	0001	0	1	X	Lost arbitration due to a detected STOP.	Abort failed transfer.	0	0	X	-
						Reschedule failed transfer.	1	0	X	1110
	0000	1	1	X	Lost arbitration while transmitting a data byte as master.	Abort failed transfer.	0	0	0	-
						Reschedule failed transfer.	1	0	0	1110

Table 28.6. SMBus Status Decoding With Hardware ACK Generation Enabled (EHACK = 1)

Mode	Values Read			Current SMBus State	Typical Response Options	Values to Write			Next Status Vector Expected	
	Status Vector	ACKRQ	ARBLOST			ACK	STA	STO		ACK
Master Transmitter	1110	0	0	X	A master START was generated.	Load slave address + R/W into SMB0DAT.	0	0	X	1100
	1100	0	0	0	A master data or address byte was transmitted; NACK received.	Set STA to restart transfer.	1	0	X	1110
						Abort transfer.	0	1	X	-
		0	0	1	A master data or address byte was transmitted; ACK received.	Load next data byte into SMB0DAT.	0	0	X	1100
						End transfer with STOP.	0	1	X	-
						End transfer with STOP and start another transfer.	1	1	X	-
						Send repeated START.	1	0	X	1110
				Switch to Master Receiver Mode (clear SI without writing new data to SMB0DAT). Set ACK for initial data byte.	0	0	1	1000		
Master Receiver	1000	0	0	1	A master data byte was received; ACK sent.	Set ACK for next data byte; Read SMB0DAT.	0	0	1	1000
						Set NACK to indicate next data byte as the last data byte; Read SMB0DAT.	0	0	0	1000
						Initiate repeated START.	1	0	0	1110
						Switch to Master Transmitter Mode (write to SMB0DAT before clearing SI).	0	0	X	1100
	0	0	0	0	A master data byte was received; NACK sent (last byte).	Read SMB0DAT; send STOP.	0	1	0	-
						Read SMB0DAT; Send STOP followed by START.	1	1	0	1110
						Initiate repeated START.	1	0	0	1110
						Switch to Master Transmitter Mode (write to SMB0DAT before clearing SI).	0	0	X	1100

Table 28.6. SMBus Status Decoding With Hardware ACK Generation Enabled (EHACK = 1)

Mode	Values Read			Current SMBus State	Typical Response Options	Values to Write			Next Status Vector Expected	
	Status Vector	ACKRQ	ARBLOST			ACK	STA	STO		ACK
Slave Transmitter	0100	0	0	0	A slave byte was transmitted; NACK received.	No action required (expecting STOP condition).	0	0	X	0001
		0	0	1	A slave byte was transmitted; ACK received.	Load SMB0DAT with next data byte to transmit.	0	0	X	0100
		0	1	X	A Slave byte was transmitted; error detected.	No action required (expecting Master to end transfer).	0	0	X	0001
	0101	0	X	X	An illegal STOP or bus error was detected while a Slave Transmission was in progress.	Clear STO.	0	0	X	—
Slave Receiver	0010	0	0	X	A slave address + R/W was received; ACK sent.	If Write, Set ACK for first data byte.	0	0	1	0000
						If Read, Load SMB0DAT with data byte	0	0	X	0100
		0	1	X	Lost arbitration as master; slave address + R/W received; ACK sent.	If Write, Set ACK for first data byte.	0	0	1	0000
						If Read, Load SMB0DAT with data byte	0	0	X	0100
	0001	0	0	X	A STOP was detected while addressed as a Slave Transmitter or Slave Receiver.	Clear STO.	0	0	X	—
						0	1	X	Lost arbitration while attempting a STOP.	No action required (transfer complete/aborted).
	0000	0	0	X	A slave byte was received.	Set ACK for next data byte; Read SMB0DAT.	0	0	1	0000
						Set NACK for next data byte; Read SMB0DAT.	0	0	0	0000
Bus Error Condition	0010	0	1	X	Lost arbitration while attempting a repeated START.	Abort failed transfer.	0	0	X	—
						Reschedule failed transfer.	1	0	X	1110
	0001	0	1	X	Lost arbitration due to a detected STOP.	Abort failed transfer.	0	0	X	—
						Reschedule failed transfer.	1	0	X	1110
	0000	0	1	X	Lost arbitration while transmitting a data byte as master.	Abort failed transfer.	0	0	X	—
						Reschedule failed transfer.	1	0	X	1110

29. UART0

UART0 is an asynchronous, full duplex serial port offering modes 1 and 3 of the standard 8051 UART. Enhanced baud rate support allows a wide range of clock sources to generate standard baud rates (details in Section “29.1. Enhanced Baud Rate Generation” on page 410). Received data buffering allows UART0 to start reception of a second incoming data byte before software has finished reading the previous data byte.

UART0 has two associated SFRs: Serial Control Register 0 (SCON0) and Serial Data Buffer 0 (SBUF0). The single SBUF0 location provides access to both transmit and receive registers. **Writes to SBUF0 always access the Transmit register. Reads of SBUF0 always access the buffered Receive register; it is not possible to read data from the Transmit register.**

With UART0 interrupts enabled, an interrupt is generated each time a transmit is completed (TI0 is set in SCON0), or a data byte has been received (RI0 is set in SCON0). The UART0 interrupt flags are not cleared by hardware when the CPU vectors to the interrupt service routine. They must be cleared manually by software, allowing software to determine the cause of the UART0 interrupt (transmit complete or receive complete).

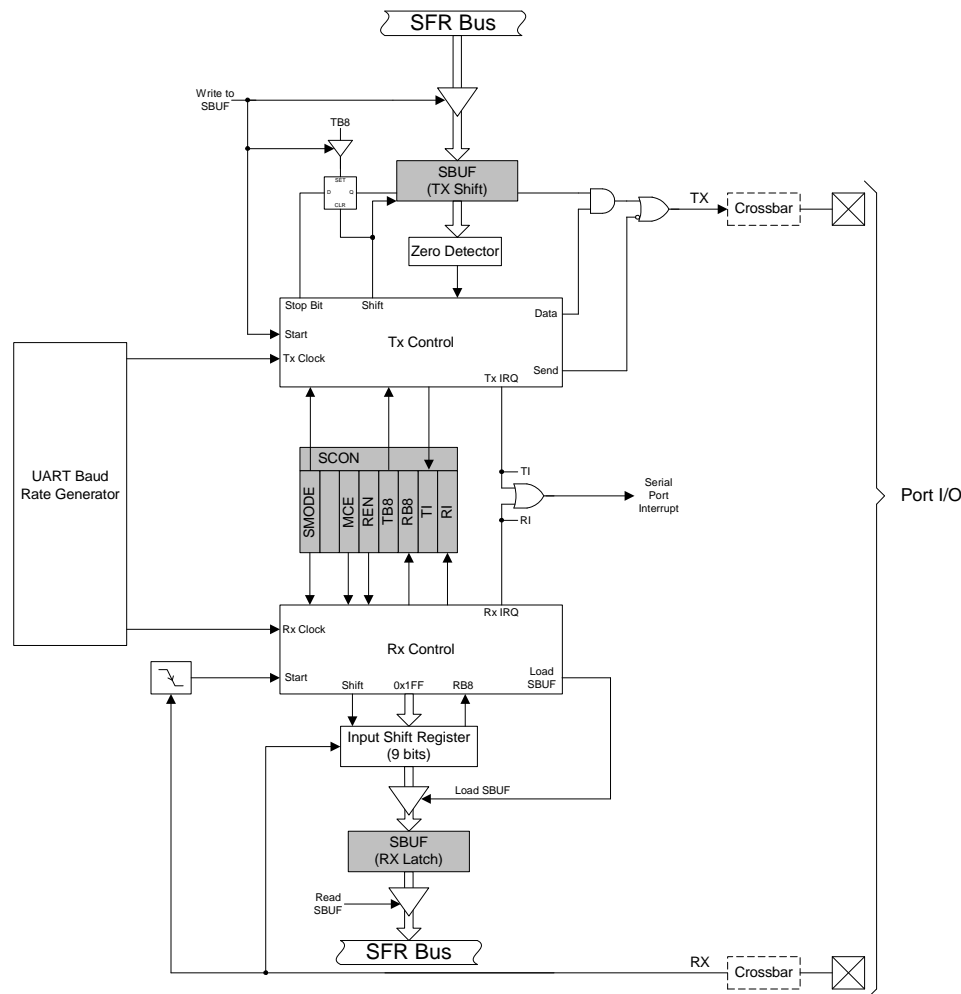

Figure 29.1. UART0 Block Diagram

29.1. Enhanced Baud Rate Generation

The UART0 baud rate is generated by Timer 1 in 8-bit auto-reload mode. The TX clock is generated by TL1; the RX clock is generated by a copy of TL1 (shown as RX Timer in Figure 29.2), which is not user-accessible. Both TX and RX Timer overflows are divided by two to generate the TX and RX baud rates. The RX Timer runs when Timer 1 is enabled, and uses the same reload value (TH1). However, an RX Timer reload is forced when a START condition is detected on the RX pin. This allows a receive to begin any time a START is detected, independent of the TX Timer state.

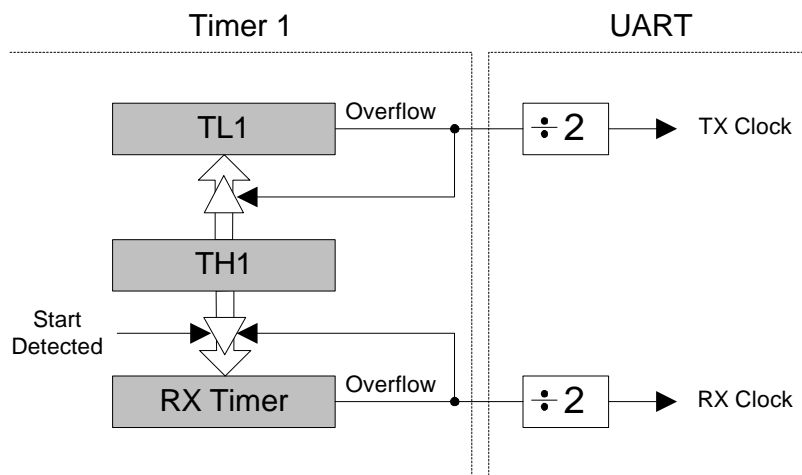

Figure 29.2. UART0 Baud Rate Logic

Timer 1 should be configured for Mode 2, 8-bit auto-reload (see Section “33.1.3. Mode 2: 8-bit Counter/Timer with Auto-Reload” on page 494). The Timer 1 reload value should be set so that overflows will occur at two times the desired UART baud rate frequency. Note that Timer 1 may be clocked by one of six sources: SYSCLK, SYSCLK / 4, SYSCLK / 12, SYSCLK / 48, the external oscillator clock / 8, or an external input T1. For any given Timer 1 clock source, the UART0 baud rate is determined by Equation -A and Equation -B.

$$A) \quad \text{UartBaudRate} = \frac{1}{2} \times \text{T1_Overflow_Rate}$$

$$B) \quad \text{T1_Overflow_Rate} = \frac{\text{T1}_{\text{CLK}}}{256 - \text{TH1}}$$

UART0 Baud Rate

Where $T1_{\text{CLK}}$ is the frequency of the clock supplied to Timer 1, and $T1H$ is the high byte of Timer 1 (reload value). Timer 1 clock frequency is selected as described in Section “33.1. Timer 0 and Timer 1” on page 493. A quick reference for typical baud rates and system clock frequencies is given in Table 29.1 through Table 29.2. Note that the internal oscillator may still generate the system clock when the external oscillator is driving Timer 1.

29.2. Operational Modes

UART0 provides standard asynchronous, full duplex communication. The UART mode (8-bit or 9-bit) is selected by the S0MODE bit (SCON0.7). Typical UART connection options are shown below.

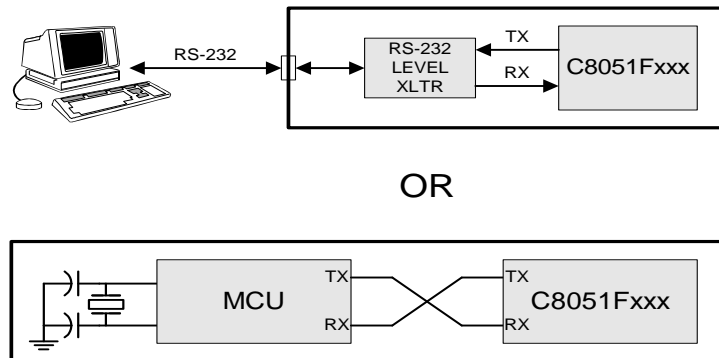

Figure 29.3. UART Interconnect Diagram

29.2.1. 8-Bit UART

8-Bit UART mode uses a total of 10 bits per data byte: one start bit, eight data bits (LSB first), and one stop bit. Data are transmitted LSB first from the TX0 pin and received at the RX0 pin. On receive, the eight data bits are stored in SBUF0 and the stop bit goes into RB80 (SCON0.2).

Data transmission begins when software writes a data byte to the SBUF0 register. The T10 Transmit Interrupt Flag (SCON0.1) is set at the end of the transmission (the beginning of the stop-bit time). Data reception can begin any time after the REN0 Receive Enable bit (SCON0.4) is set to logic 1. After the stop bit is received, the data byte will be loaded into the SBUF0 receive register if the following conditions are met: RI0 must be logic 0, and if MCE0 is logic 1, the stop bit must be logic 1. In the event of a receive data overrun, the first received 8 bits are latched into the SBUF0 receive register and the following overrun data bits are lost.

If these conditions are met, the eight bits of data is stored in SBUF0, the stop bit is stored in RB80 and the RI0 flag is set. If these conditions are not met, SBUF0 and RB80 will not be loaded and the RI0 flag will not be set. An interrupt will occur if enabled when either T10 or RI0 is set.

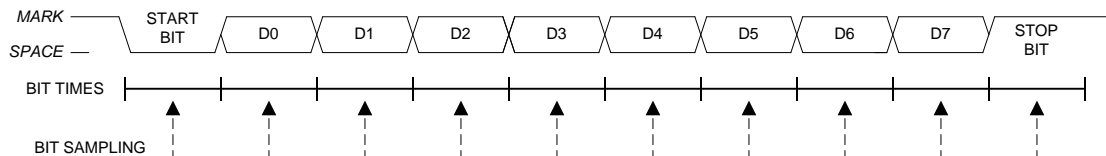

Figure 29.4. 8-Bit UART Timing Diagram

29.2.2. 9-Bit UART

9-bit UART mode uses a total of eleven bits per data byte: a start bit, 8 data bits (LSB first), a programmable ninth data bit, and a stop bit. The state of the ninth transmit data bit is determined by the value in TB80 (SCON0.3), which is assigned by user software. It can be assigned the value of the parity flag (bit P in register PSW) for error detection, or used in multiprocessor communications. On receive, the ninth data bit goes into RB80 (SCON0.2) and the stop bit is ignored.

Data transmission begins when an instruction writes a data byte to the SBUF0 register. The TIO Transmit Interrupt Flag (SCON0.1) is set at the end of the transmission (the beginning of the stop-bit time). Data reception can begin any time after the REN0 Receive Enable bit (SCON0.4) is set to 1. After the stop bit is received, the data byte will be loaded into the SBUF0 receive register if the following conditions are met: (1) RI0 must be logic 0, and (2) if MCE0 is logic 1, the 9th bit must be logic 1 (when MCE0 is logic 0, the state of the ninth data bit is unimportant). If these conditions are met, the eight bits of data are stored in SBUF0, the ninth bit is stored in RB80, and the RI0 flag is set to 1. If the above conditions are not met, SBUF0 and RB80 will not be loaded and the RI0 flag will not be set to 1. A UART0 interrupt will occur if enabled when either TIO or RI0 is set to 1.

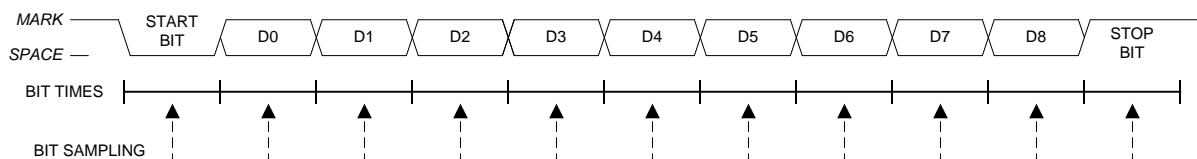

Figure 29.5. 9-Bit UART Timing Diagram

29.3. Multiprocessor Communications

9-Bit UART mode supports multiprocessor communication between a master processor and one or more slave processors by special use of the ninth data bit. When a master processor wants to transmit to one or more slaves, it first sends an address byte to select the target(s). An address byte differs from a data byte in that its ninth bit is logic 1; in a data byte, the ninth bit is always set to logic 0.

Setting the MCE0 bit (SCON0.5) of a slave processor configures its UART such that when a stop bit is received, the UART will generate an interrupt only if the ninth bit is logic 1 (RB80 = 1) signifying an address byte has been received. In the UART interrupt handler, software will compare the received address with the slave's own assigned 8-bit address. If the addresses match, the slave will clear its MCE0 bit to enable interrupts on the reception of the following data byte(s). Slaves that weren't addressed leave their MCE0 bits set and do not generate interrupts on the reception of the following data bytes, thereby ignoring the data. Once the entire message is received, the addressed slave resets its MCE0 bit to ignore all transmissions until it receives the next address byte.

Multiple addresses can be assigned to a single slave and/or a single address can be assigned to multiple slaves, thereby enabling "broadcast" transmissions to more than one slave simultaneously. The master processor can be configured to receive all transmissions or a protocol can be implemented such that the master/slave role is temporarily reversed to enable half-duplex transmission between the original master and slave(s).

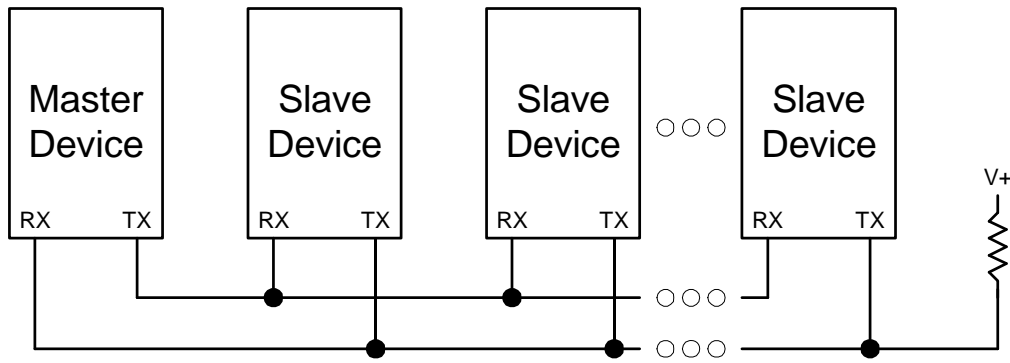

Figure 29.6. UART Multi-Processor Mode Interconnect Diagram

Si102x/3x

SFR Definition 29.1. SCON0: Serial Port 0 Control

Bit	7	6	5	4	3	2	1	0
Name	S0MODE		MCE0	REN0	TB80	RB80	TI0	RI0
Type	R/W	R	R/W	R/W	R/W	R/W	R/W	R/W
Reset	0	1	0	0	0	0	0	0

SFR Page = 0x0; SFR Address = 0x98; Bit-Addressable

Bit	Name	Function
7	S0MODE	Serial Port 0 Operation Mode. Selects the UART0 Operation Mode. 0: 8-bit UART with Variable Baud Rate. 1: 9-bit UART with Variable Baud Rate.
6	Unused	Read = 1b. Write = Don't Care.
5	MCE0	Multiprocessor Communication Enable. For Mode 0 (8-bit UART): Checks for valid stop bit. 0: Logic level of stop bit is ignored. 1: RI0 will only be activated if stop bit is logic level 1. For Mode 1 (9-bit UART): Multiprocessor Communications Enable. 0: Logic level of ninth bit is ignored. 1: RI0 is set and an interrupt is generated only when the ninth bit is logic 1.
4	REN0	Receive Enable. 0: UART0 reception disabled. 1: UART0 reception enabled.
3	TB80	Ninth Transmission Bit. The logic level of this bit will be sent as the ninth transmission bit in 9-bit UART Mode (Mode 1). Unused in 8-bit mode (Mode 0).
2	RB80	Ninth Receive Bit. RB80 is assigned the value of the STOP bit in Mode 0; it is assigned the value of the 9th data bit in Mode 1.
1	TI0	Transmit Interrupt Flag. Set by hardware when a byte of data has been transmitted by UART0 (after the 8th bit in 8-bit UART Mode, or at the beginning of the STOP bit in 9-bit UART Mode). When the UART0 interrupt is enabled, setting this bit causes the CPU to vector to the UART0 interrupt service routine. This bit must be cleared manually by software.
0	RI0	Receive Interrupt Flag. Set to 1 by hardware when a byte of data has been received by UART0 (set at the STOP bit sampling time). When the UART0 interrupt is enabled, setting this bit to 1 causes the CPU to vector to the UART0 interrupt service routine. This bit must be cleared manually by software.

SFR Definition 29.2. SBUF0: Serial (UART0) Port Data Buffer

Bit	7	6	5	4	3	2	1	0
Name	SBUF0[7:0]							
Type	R/W	R/W	R/W	R/W	R/W	R/W	R/W	R/W
Reset	0	0	0	0	0	0	0	0

SFR Page = 0x0; SFR Address = 0x99

Bit	Name	Function
7:0	SBUF0	<p>Serial Data Buffer Bits 7:0 (MSB–LSB).</p> <p>This SFR accesses two registers; a transmit shift register and a receive latch register. When data is written to SBUF0, it goes to the transmit shift register and is held for serial transmission. Writing a byte to SBUF0 initiates the transmission. A read of SBUF0 returns the contents of the receive latch.</p>

Table 29.1. Timer Settings for Standard Baud Rates Using The Internal 24.5 MHz Oscillator

Frequency: 24.5 MHz							
	Target Baud Rate (bps)	Baud Rate % Error	Oscillator Divide Factor	Timer Clock Source	SCA1–SCA0 (pre-scale select) ¹	T1M ¹	Timer 1 Reload Value (hex)
SYSCLK from Internal Osc.	230400	-0.32%	106	SYSCLK	XX ²	1	0xCB
	115200	-0.32%	212	SYSCLK	XX	1	0x96
	57600	0.15%	426	SYSCLK	XX	1	0x2B
	28800	-0.32%	848	SYSCLK/4	01	0	0x96
	14400	0.15%	1704	SYSCLK/12	00	0	0xB9
	9600	-0.32%	2544	SYSCLK/12	00	0	0x96
	2400	-0.32%	10176	SYSCLK/48	10	0	0x96
	1200	0.15%	20448	SYSCLK/48	10	0	0x2B

Notes:

1. SCA1–SCA0 and T1M bit definitions can be found in Section 33.1.
2. X = Don't care.

Table 29.2. Timer Settings for Standard Baud Rates Using an External 22.1184 MHz Oscillator

Frequency: 22.1184 MHz							
	Target Baud Rate (bps)	Baud Rate % Error	Oscillator Divide Factor	Timer Clock Source	SCA1–SCA0 (pre-scale select) ¹	T1M ¹	Timer 1 Reload Value (hex)
SYSCLK from External Osc.	230400	0.00%	96	SYSCLK	XX ²	1	0xD0
	115200	0.00%	192	SYSCLK	XX	1	0xA0
	57600	0.00%	384	SYSCLK	XX	1	0x40
	28800	0.00%	768	SYSCLK / 12	00	0	0xE0
	14400	0.00%	1536	SYSCLK / 12	00	0	0xC0
	9600	0.00%	2304	SYSCLK / 12	00	0	0xA0
	2400	0.00%	9216	SYSCLK / 48	10	0	0xA0
	1200	0.00%	18432	SYSCLK / 48	10	0	0x40

**Table 29.2. Timer Settings for Standard Baud Rates
Using an External 22.1184 MHz Oscillator**

Frequency: 22.1184 MHz							
	Target Baud Rate (bps)	Baud Rate % Error	Oscillator Divide Factor	Timer Clock Source	SCA1–SCA0 (pre-scale select) ¹	T1M ¹	Timer 1 Reload Value (hex)
SYSCLK from Internal Osc.	230400	0.00%	96	EXTCLK / 8	11	0	0xFA
	115200	0.00%	192	EXTCLK / 8	11	0	0xF4
	57600	0.00%	384	EXTCLK / 8	11	0	0xE8
	28800	0.00%	768	EXTCLK / 8	11	0	0xD0
	14400	0.00%	1536	EXTCLK / 8	11	0	0xA0
	9600	0.00%	2304	EXTCLK / 8	11	0	0x70

Notes:

1. SCA1–SCA0 and T1M bit definitions can be found in Section 33.1.
2. X = Don't care.

30. Enhanced Serial Peripheral Interface (SPI0)

The Enhanced Serial Peripheral Interface (SPI0) provides access to a flexible, full-duplex synchronous serial bus. SPI0 can operate as a master or slave device in both 3-wire or 4-wire modes, and supports multiple masters and slaves on a single SPI bus. The slave-select (NSS) signal can be configured as an input to select SPI0 in slave mode, or to disable Master Mode operation in a multi-master environment, avoiding contention on the SPI bus when more than one master attempts simultaneous data transfers. NSS can also be configured as a chip-select output in master mode, or disabled for 3-wire operation. Additional general purpose port I/O pins can be used to select multiple slave devices in master mode.

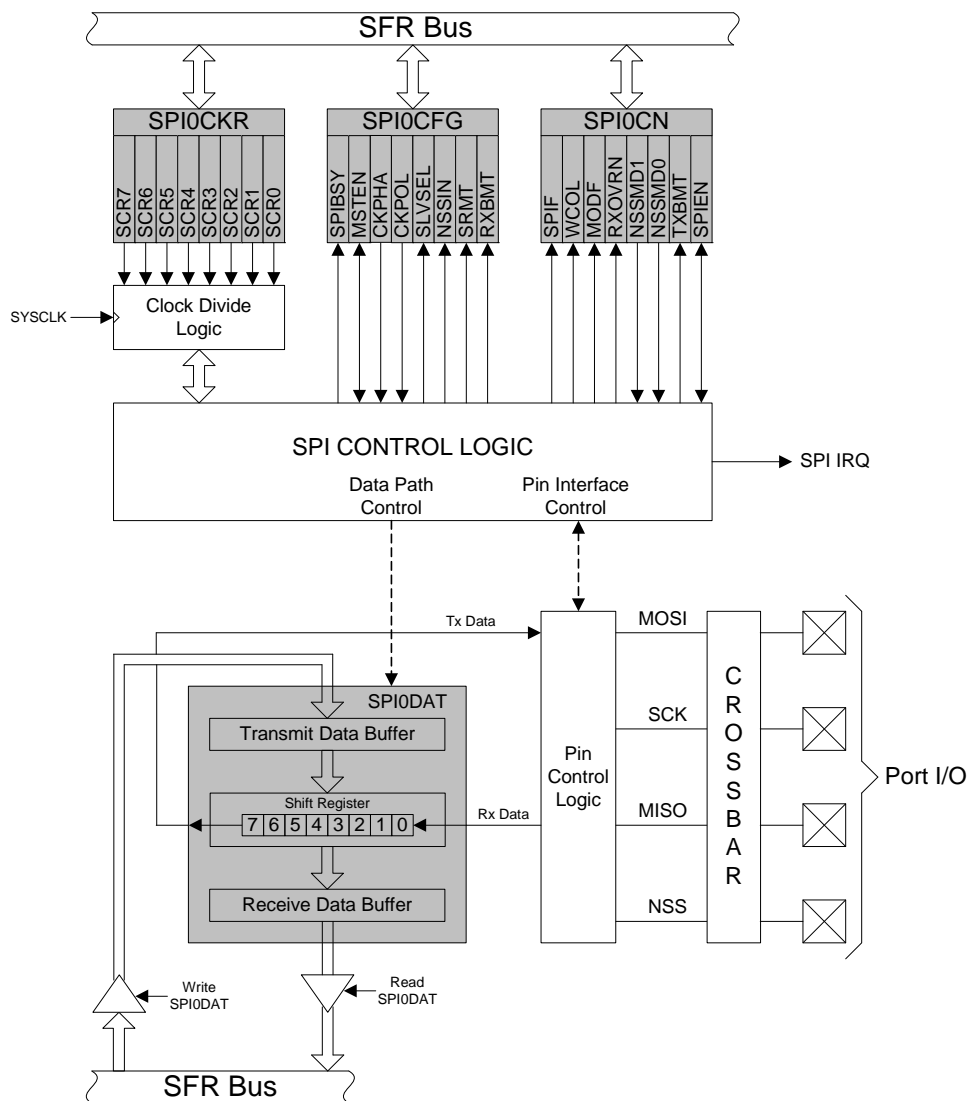

Figure 30.1. SPI Block Diagram

30.1. Signal Descriptions

The four signals used by SPI0 (MOSI, MISO, SCK, NSS) are described below.

30.1.1. Master Out, Slave In (MOSI)

The master-out, slave-in (MOSI) signal is an output from a master device and an input to slave devices. It is used to serially transfer data from the master to the slave. This signal is an output when SPI0 is operating as a master and an input when SPI0 is operating as a slave. Data is transferred most-significant bit first. When configured as a master, MOSI is driven by the MSB of the shift register in both 3- and 4-wire mode.

30.1.2. Master In, Slave Out (MISO)

The master-in, slave-out (MISO) signal is an output from a slave device and an input to the master device. It is used to serially transfer data from the slave to the master. This signal is an input when SPI0 is operating as a master and an output when SPI0 is operating as a slave. Data is transferred most-significant bit first. The MISO pin is placed in a high-impedance state when the SPI module is disabled and when the SPI operates in 4-wire mode as a slave that is not selected. When acting as a slave in 3-wire mode, MISO is always driven by the MSB of the shift register.

30.1.3. Serial Clock (SCK)

The serial clock (SCK) signal is an output from the master device and an input to slave devices. It is used to synchronize the transfer of data between the master and slave on the MOSI and MISO lines. SPI0 generates this signal when operating as a master. The SCK signal is ignored by a SPI slave when the slave is not selected (NSS = 1) in 4-wire slave mode.

30.1.4. Slave Select (NSS)

The function of the slave-select (NSS) signal is dependent on the setting of the NSSMD1 and NSSMD0 bits in the SPI0CN register. There are three possible modes that can be selected with these bits:

1. NSSMD[1:0] = 00: 3-Wire Master or 3-Wire Slave Mode: SPI0 operates in 3-wire mode, and NSS is disabled. When operating as a slave device, SPI0 is always selected in 3-wire mode. Since no select signal is present, SPI0 must be the only slave on the bus in 3-wire mode. This is intended for point-to-point communication between a master and one slave.
2. NSSMD[1:0] = 01: 4-Wire Slave or Multi-Master Mode: SPI0 operates in 4-wire mode, and NSS is enabled as an input. When operating as a slave, NSS selects the SPI0 device. When operating as a master, a 1-to-0 transition of the NSS signal disables the master function of SPI0 so that multiple master devices can be used on the same SPI bus.
3. NSSMD[1:0] = 1x: 4-Wire Master Mode: SPI0 operates in 4-wire mode, and NSS is enabled as an output. The setting of NSSMD0 determines what logic level the NSS pin will output. This configuration should only be used when operating SPI0 as a master device.

See Figure 30.2, Figure 30.3, and Figure 30.4 for typical connection diagrams of the various operational modes. **Note that the setting of NSSMD bits affects the pinout of the device.** When in 3-wire master or 3-wire slave mode, the NSS pin will not be mapped by the crossbar. In all other modes, the NSS signal will be mapped to a pin on the device. See Section “27. Port Input/Output” on page 358 for general purpose port I/O and crossbar information.

30.2. SPI0 Master Mode Operation

A SPI master device initiates all data transfers on a SPI bus. SPI0 is placed in master mode by setting the Master Enable flag (MSTEN, SPI0CN.6). Writing a byte of data to the SPI0 data register (SPI0DAT) when in master mode writes to the transmit buffer. If the SPI shift register is empty, the byte in the transmit buffer is moved to the shift register, and a data transfer begins. The SPI0 master immediately shifts out the data serially on the MOSI line while providing the serial clock on SCK. The SPIF (SPI0CN.7) flag is set to logic 1 at the end of the transfer. If interrupts are enabled, an interrupt request is generated when the SPIF flag

Si102x/3x

is set. While the SPI0 master transfers data to a slave on the MOSI line, the addressed SPI slave device simultaneously transfers the contents of its shift register to the SPI master on the MISO line in a full-duplex operation. Therefore, the SPIF flag serves as both a transmit-complete and receive-data-ready flag. The data byte received from the slave is transferred MSB-first into the master's shift register. When a byte is fully shifted into the register, it is moved to the receive buffer where it can be read by the processor by reading SPI0DAT.

When configured as a master, SPI0 can operate in one of three different modes: multi-master mode, 3-wire single-master mode, and 4-wire single-master mode. The default, multi-master mode is active when NSSMD1 (SPI0CN.3) = 0 and NSSMD0 (SPI0CN.2) = 1. In this mode, NSS is an input to the device, and is used to disable the master SPI0 when another master is accessing the bus. When NSS is pulled low in this mode, MSTEN (SPI0CN.6) and SPIEN (SPI0CN.0) are set to 0 to disable the SPI master device, and a Mode Fault is generated (MODF, SPI0CN.5 = 1). Mode Fault will generate an interrupt if enabled. SPI0 must be manually re-enabled in software under these circumstances. In multi-master systems, devices will typically default to being slave devices while they are not acting as the system master device. In multi-master mode, slave devices can be addressed individually (if needed) using general-purpose I/O pins. Figure 30.2 shows a connection diagram between two master devices in multiple-master mode.

3-wire single-master mode is active when NSSMD1 (SPI0CN.3) = 0 and NSSMD0 (SPI0CN.2) = 0. In this mode, NSS is not used, and is not mapped to an external port pin through the crossbar. Any slave devices that must be addressed in this mode should be selected using general-purpose I/O pins. Figure 30.3 shows a connection diagram between a master device in 3-wire master mode and a slave device.

4-wire single-master mode is active when NSSMD1 (SPI0CN.3) = 1. In this mode, NSS is configured as an output pin, and can be used as a slave-select signal for a single SPI device. In this mode, the output value of NSS is controlled (in software) with the bit NSSMD0 (SPI0CN.2). Additional slave devices can be addressed using general-purpose I/O pins. Figure 30.4 shows a connection diagram for a master device in 4-wire master mode and two slave devices.

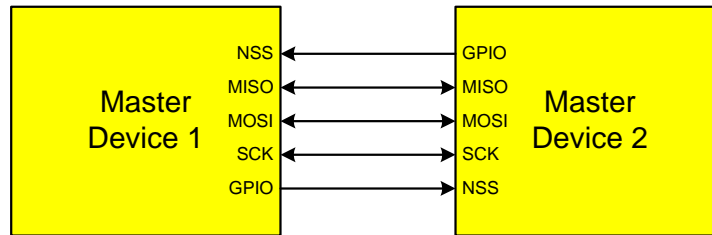

Figure 30.2. Multiple-Master Mode Connection Diagram

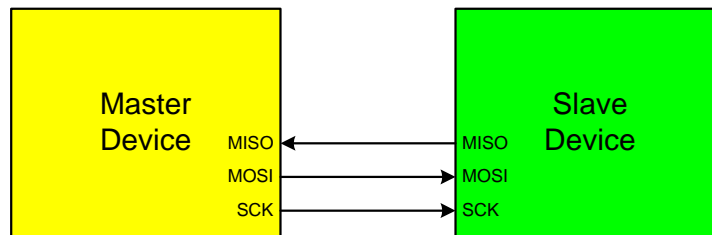

Figure 30.3. 3-Wire Single Master and 3-Wire Single Slave Mode Connection Diagram

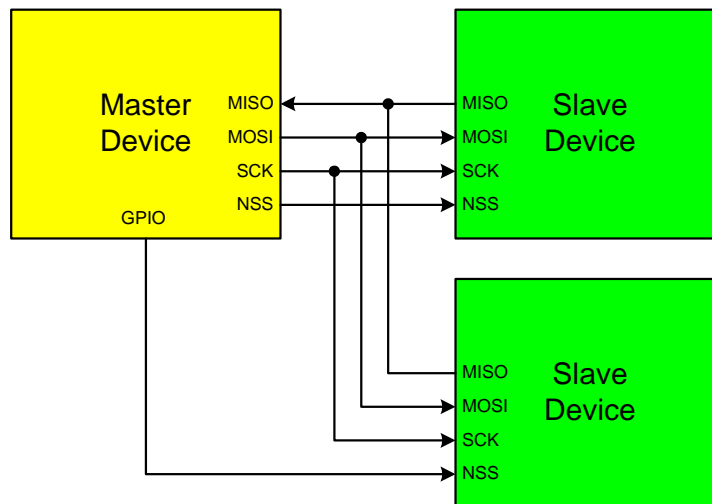

Figure 30.4. 4-Wire Single Master Mode and 4-Wire Slave Mode Connection Diagram

30.3. SPI0 Slave Mode Operation

When SPI0 is enabled and not configured as a master, it will operate as a SPI slave. As a slave, bytes are shifted in through the MOSI pin and out through the MISO pin by a master device controlling the SCK signal. A bit counter in the SPI0 logic counts SCK edges. When 8 bits have been shifted through the shift register, the SPIF flag is set to logic 1, and the byte is copied into the receive buffer. Data is read from the receive buffer by reading SPI0DAT. A slave device cannot initiate transfers. Data to be transferred to the master device is pre-loaded into the shift register by writing to SPI0DAT. Writes to SPI0DAT are double-buffered, and are placed in the transmit buffer first. If the shift register is empty, the contents of the transmit buffer will immediately be transferred into the shift register. When the shift register already contains data,

Si102x/3x

the SPI will load the shift register with the transmit buffer's contents after the last SCK edge of the next (or current) SPI transfer.

When configured as a slave, SPI0 can be configured for 4-wire or 3-wire operation. The default, 4-wire slave mode, is active when NSSMD1 (SPI0CN.3) = 0 and NSSMD0 (SPI0CN.2) = 1. In 4-wire mode, the NSS signal is routed to a port pin and configured as a digital input. SPI0 is enabled when NSS is logic 0, and disabled when NSS is logic 1. The bit counter is reset on a falling edge of NSS. Note that the NSS signal must be driven low at least 2 system clocks before the first active edge of SCK for each byte transfer. Figure 30.4 shows a connection diagram between two slave devices in 4-wire slave mode and a master device.

3-wire slave mode is active when NSSMD1 (SPI0CN.3) = 0 and NSSMD0 (SPI0CN.2) = 0. NSS is not used in this mode, and is not mapped to an external port pin through the crossbar. Since there is no way of uniquely addressing the device in 3-wire slave mode, SPI0 must be the only slave device present on the bus. It is important to note that in 3-wire slave mode there is no external means of resetting the bit counter that determines when a full byte has been received. The bit counter can only be reset by disabling and re-enabling SPI0 with the SPIEN bit. Figure 30.3 shows a connection diagram between a slave device in 3-wire slave mode and a master device.

30.4. SPI0 Interrupt Sources

When SPI0 interrupts are enabled, the following four flags will generate an interrupt when they are set to logic 1:

All of the following bits must be cleared by software.

- The SPI Interrupt Flag, SPIF (SPI0CN.7) is set to logic 1 at the end of each byte transfer. This flag can occur in all SPI0 modes.
- The Write Collision Flag, WCOL (SPI0CN.6) is set to logic 1 if a write to SPI0DAT is attempted when the transmit buffer has not been emptied to the SPI shift register. When this occurs, the write to SPI0DAT will be ignored, and the transmit buffer will not be written. This flag can occur in all SPI0 modes.
- The Mode Fault Flag MODF (SPI0CN.5) is set to logic 1 when SPI0 is configured as a master, and for multi-master mode and the NSS pin is pulled low. When a Mode Fault occurs, the MSTEN and SPIEN bits in SPI0CN are set to logic 0 to disable SPI0 and allow another master device to access the bus.
- The Receive Overrun Flag RXOVRN (SPI0CN.4) is set to logic 1 when configured as a slave, and a transfer is completed and the receive buffer still holds an unread byte from a previous transfer. The new byte is not transferred to the receive buffer, allowing the previously received data byte to be read. The data byte which caused the overrun is lost.

30.5. Serial Clock Phase and Polarity

Four combinations of serial clock phase and polarity can be selected using the clock control bits in the SPI0 Configuration Register (SPI0CFG). The CKPHA bit (SPI0CFG.5) selects one of two clock phases (edge used to latch the data). The CKPOL bit (SPI0CFG.4) selects between an active-high or active-low clock. Both master and slave devices must be configured to use the same clock phase and polarity. SPI0 should be disabled (by clearing the SPIEN bit, SPI0CN.0) when changing the clock phase or polarity. The clock and data line relationships for master mode are shown in Figure 30.5. For slave mode, the clock and data relationships are shown in Figure 30.6 and Figure 30.7. Note that CKPHA should be set to 0 on both the master and slave SPI when communicating between two Silicon Labs C8051 devices.

The SPI0 Clock Rate Register (SPI0CKR) as shown in SFR Definition 30.3 controls the master mode serial clock frequency. This register is ignored when operating in slave mode. When the SPI is configured as a master, the maximum data transfer rate (bits/sec) is one-half the system clock frequency or 12.5 MHz, whichever is slower. When the SPI is configured as a slave, the maximum data transfer rate (bits/sec) for full-duplex operation is 1/10 the system clock frequency, provided that the master issues SCK, NSS (in 4-

wire slave mode), and the serial input data synchronously with the slave's system clock. If the master issues SCK, NSS, and the serial input data asynchronously, the maximum data transfer rate (bits/sec) must be less than 1/10 the system clock frequency. In the special case where the master only wants to transmit data to the slave and does not need to receive data from the slave (i.e. half-duplex operation), the SPI slave can receive data at a maximum data transfer rate (bits/sec) of 1/4 the system clock frequency. This is provided that the master issues SCK, NSS, and the serial input data synchronously with the slave's system clock.

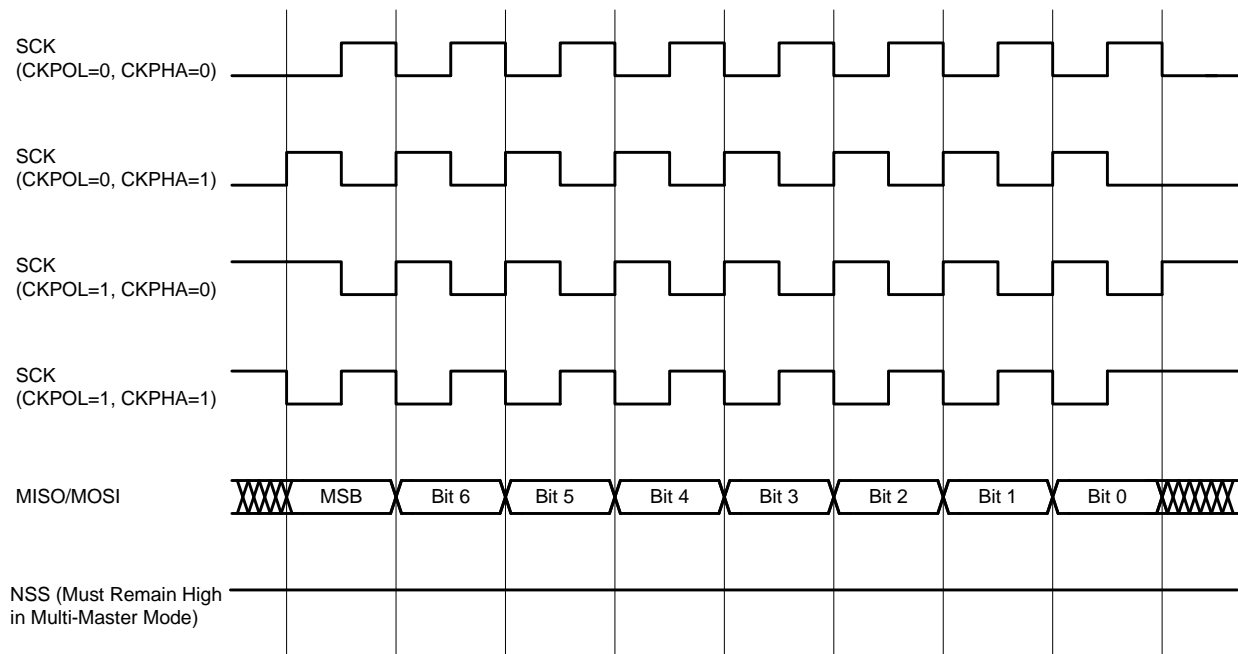

Figure 30.5. Master Mode Data/Clock Timing

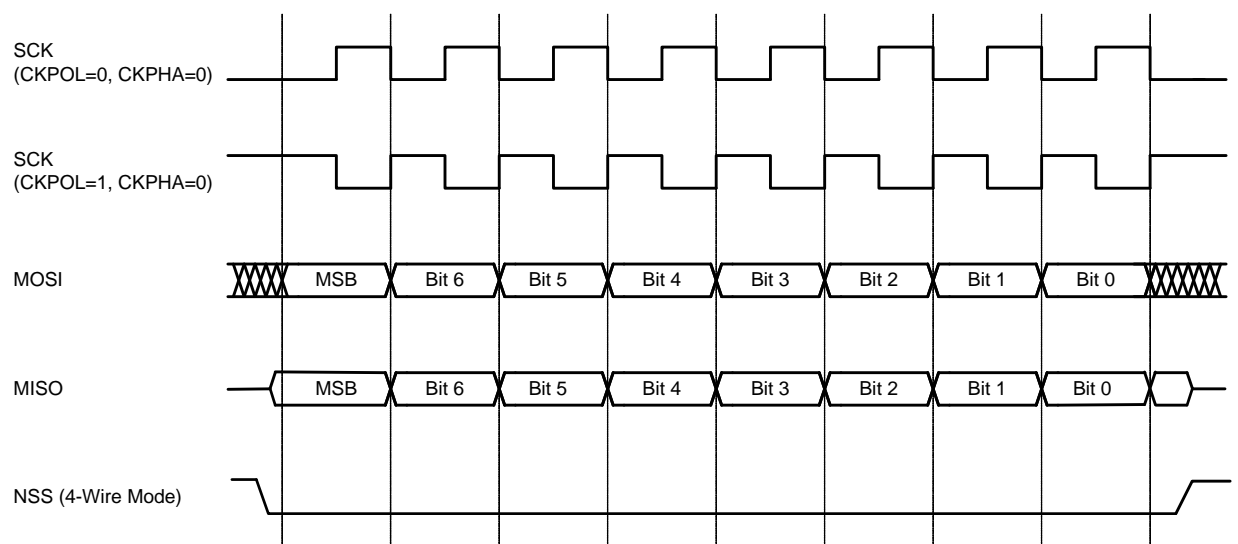

Figure 30.6. Slave Mode Data/Clock Timing (CKPHA = 0)

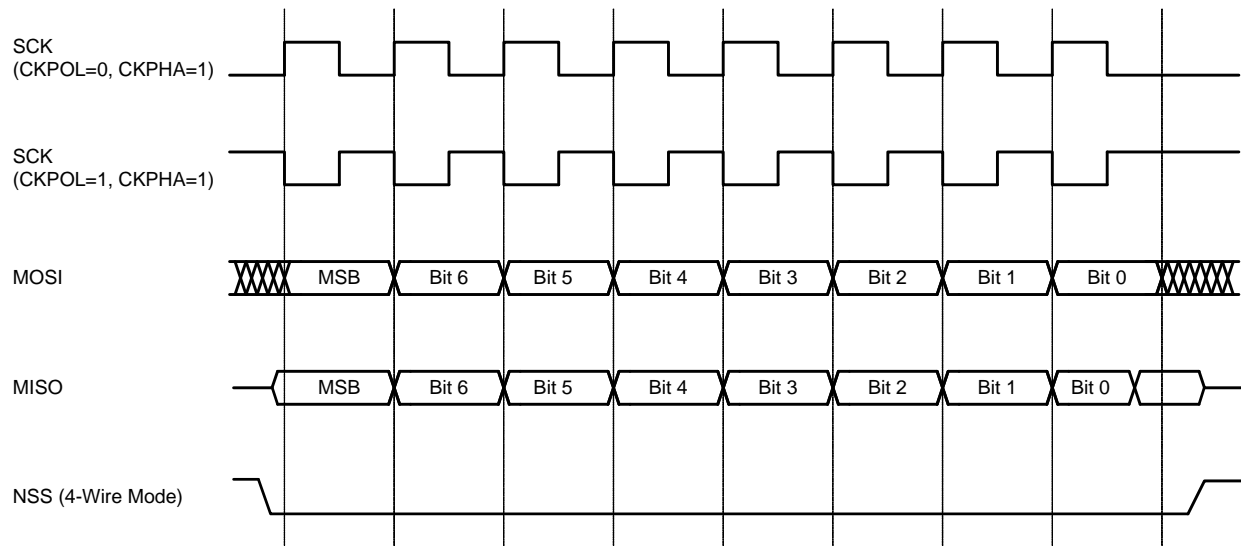

Figure 30.7. Slave Mode Data/Clock Timing (CKPHA = 1)

30.6. SPI Special Function Registers

SPI0 is accessed and controlled through four special function registers in the system controller: SPI0CN Control Register, SPI0DAT Data Register, SPI0CFG Configuration Register, and SPI0CKR Clock Rate Register. The four special function registers related to the operation of the SPI0 Bus are described in the following figures.

SFR Definition 30.1. SPI0CFG: SPI0 Configuration

Bit	7	6	5	4	3	2	1	0
Name	SPIBSY	MSTEN	CKPHA	CKPOL	SLVSEL	NSSIN	SRMT	RXBMT
Type	R	R/W	R/W	R/W	R	R	R	R
Reset	0	0	0	0	0	1	1	1

SFR Page = 0x0; SFR Address = 0xA1

Bit	Name	Function
7	SPIBSY	SPI Busy. This bit is set to logic 1 when a SPI transfer is in progress (master or slave mode).
6	MSTEN	Master Mode Enable. 0: Disable master mode. Operate in slave mode. 1: Enable master mode. Operate as a master.
5	CKPHA	SPI0 Clock Phase. 0: Data centered on first edge of SCK period.* 1: Data centered on second edge of SCK period.*
4	CKPOL	SPI0 Clock Polarity. 0: SCK line low in idle state. 1: SCK line high in idle state.
3	SLVSEL	Slave Selected Flag. This bit is set to logic 1 whenever the NSS pin is low indicating SPI0 is the selected slave. It is cleared to logic 0 when NSS is high (slave not selected). This bit does not indicate the instantaneous value at the NSS pin, but rather a de-glitched version of the pin input.
2	NSSIN	NSS Instantaneous Pin Input. This bit mimics the instantaneous value that is present on the NSS port pin at the time that the register is read. This input is not de-glitched.
1	SRMT	Shift Register Empty (valid in slave mode only). This bit will be set to logic 1 when all data has been transferred in/out of the shift register, and there is no new information available to read from the transmit buffer or write to the receive buffer. It returns to logic 0 when a data byte is transferred to the shift register from the transmit buffer or by a transition on SCK. SRMT = 1 when in Master Mode.
0	RXBMT	Receive Buffer Empty (valid in slave mode only). This bit will be set to logic 1 when the receive buffer has been read and contains no new information. If there is new information available in the receive buffer that has not been read, this bit will return to logic 0. RXBMT = 1 when in Master Mode.
Note: In slave mode, data on MOSI is sampled in the center of each data bit. In master mode, data on MISO is sampled one SYSCLK before the end of each data bit, to provide maximum settling time for the slave device. See Table 30.1 for timing parameters.		

Si102x/3x

SFR Definition 30.2. SPI0CN: SPI0 Control

Bit	7	6	5	4	3	2	1	0
Name	SPIF	WCOL	MODF	RXOVRN	NSSMD[1:0]		TXBMT	SPIEN
Type	R/W	R/W	R/W	R/W	R/W		R	R/W
Reset	0	0	0	0	0	1	1	0

SFR Page = 0x0; SFR Address = 0xF8; Bit-Addressable

Bit	Name	Function
7	SPIF	<p>SPI0 Interrupt Flag.</p> <p>This bit is set to logic 1 by hardware at the end of a data transfer. If SPI interrupts are enabled, an interrupt will be generated. This bit is not automatically cleared by hardware, and must be cleared by software.</p>
6	WCOL	<p>Write Collision Flag.</p> <p>This bit is set to logic 1 if a write to SPI0DAT is attempted when TXBMT is 0. When this occurs, the write to SPI0DAT will be ignored, and the transmit buffer will not be written. If SPI interrupts are enabled, an interrupt will be generated. This bit is not automatically cleared by hardware, and must be cleared by software.</p>
5	MODF	<p>Mode Fault Flag.</p> <p>This bit is set to logic 1 by hardware when a master mode collision is detected (NSS is low, MSTEN = 1, and NSSMD[1:0] = 01). If SPI interrupts are enabled, an interrupt will be generated. This bit is not automatically cleared by hardware, and must be cleared by software.</p>
4	RXOVRN	<p>Receive Overrun Flag (valid in slave mode only).</p> <p>This bit is set to logic 1 by hardware when the receive buffer still holds unread data from a previous transfer and the last bit of the current transfer is shifted into the SPI0 shift register. If SPI interrupts are enabled, an interrupt will be generated. This bit is not automatically cleared by hardware, and must be cleared by software.</p>
3:2	NSSMD[1:0]	<p>Slave Select Mode.</p> <p>Selects between the following NSS operation modes: (See Section 30.2 and Section 30.3).</p> <p>00: 3-Wire Slave or 3-Wire Master Mode. NSS signal is not routed to a port pin. 01: 4-Wire Slave or Multi-Master Mode (Default). NSS is an input to the device. 1x: 4-Wire Single-Master Mode. NSS signal is mapped as an output from the device and will assume the value of NSSMD0.</p>
1	TXBMT	<p>Transmit Buffer Empty.</p> <p>This bit will be set to logic 0 when new data has been written to the transmit buffer. When data in the transmit buffer is transferred to the SPI shift register, this bit will be set to logic 1, indicating that it is safe to write a new byte to the transmit buffer.</p>
0	SPIEN	<p>SPI0 Enable.</p> <p>0: SPI disabled. 1: SPI enabled.</p>

SFR Definition 30.3. SPI0CKR: SPI0 Clock Rate

Bit	7	6	5	4	3	2	1	0
Name	SCR[7:0]							
Type	R/W							
Reset	0	0	0	0	0	0	0	0

SFR Page = 0x0; SFR Address = 0xA2

Bit	Name	Function
7:0	SCR[7:0]	<p>SPI0 Clock Rate.</p> <p>These bits determine the frequency of the SCK output when the SPI0 module is configured for master mode operation. The SCK clock frequency is a divided version of the system clock, and is given in the following equation, where <i>SYSCLK</i> is the system clock frequency and <i>SPI0CKR</i> is the 8-bit value held in the SPI0CKR register.</p> $f_{SCK} = \frac{SYSCLK}{2 \times (SPI0CKR[7:0] + 1)}$ <p>for $0 \leq SPI0CKR \leq 255$</p> <p>Example: If <i>SYSCLK</i> = 2 MHz and <i>SPI0CKR</i> = 0x04,</p> $f_{SCK} = \frac{2000000}{2 \times (4 + 1)}$ $f_{SCK} = 200kHz$

SFR Definition 30.4. SPI0DAT: SPI0 Data

Bit	7	6	5	4	3	2	1	0
Name	SPI0DAT[7:0]							
Type	R/W							
Reset	0	0	0	0	0	0	0	0

SFR Page = 0x0; SFR Address = 0xA3

Bit	Name	Function
7:0	SPI0DAT[7:0]	<p>SPI0 Transmit and Receive Data.</p> <p>The SPI0DAT register is used to transmit and receive SPI0 data. Writing data to SPI0DAT places the data into the transmit buffer and initiates a transfer when in Master Mode. A read of SPI0DAT returns the contents of the receive buffer.</p>

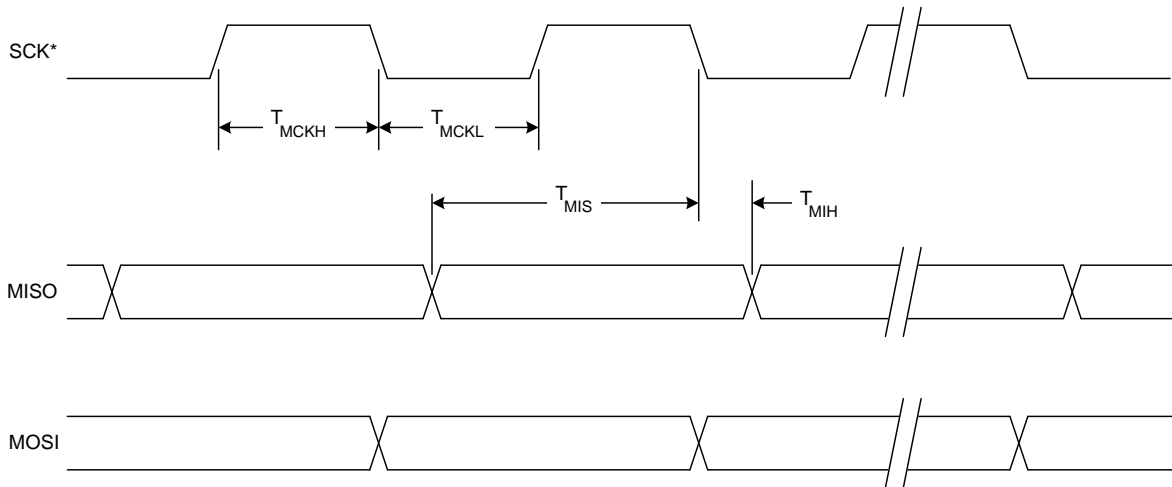

* SCK is shown for CKPOL = 0. SCK is the opposite polarity for CKPOL = 1.

Figure 30.8. SPI Master Timing (CKPHA = 0)

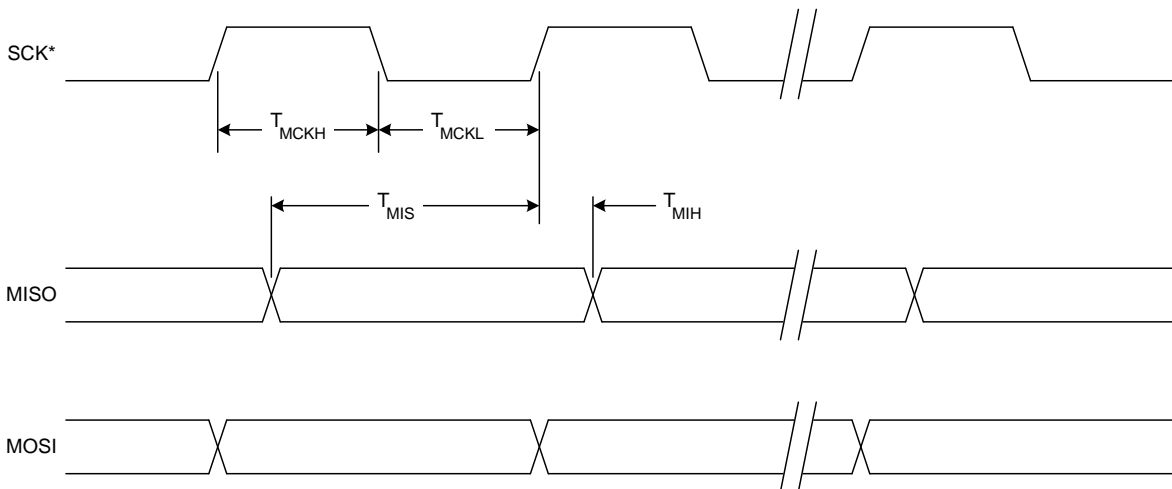

* SCK is shown for CKPOL = 0. SCK is the opposite polarity for CKPOL = 1.

Figure 30.9. SPI Master Timing (CKPHA = 1)

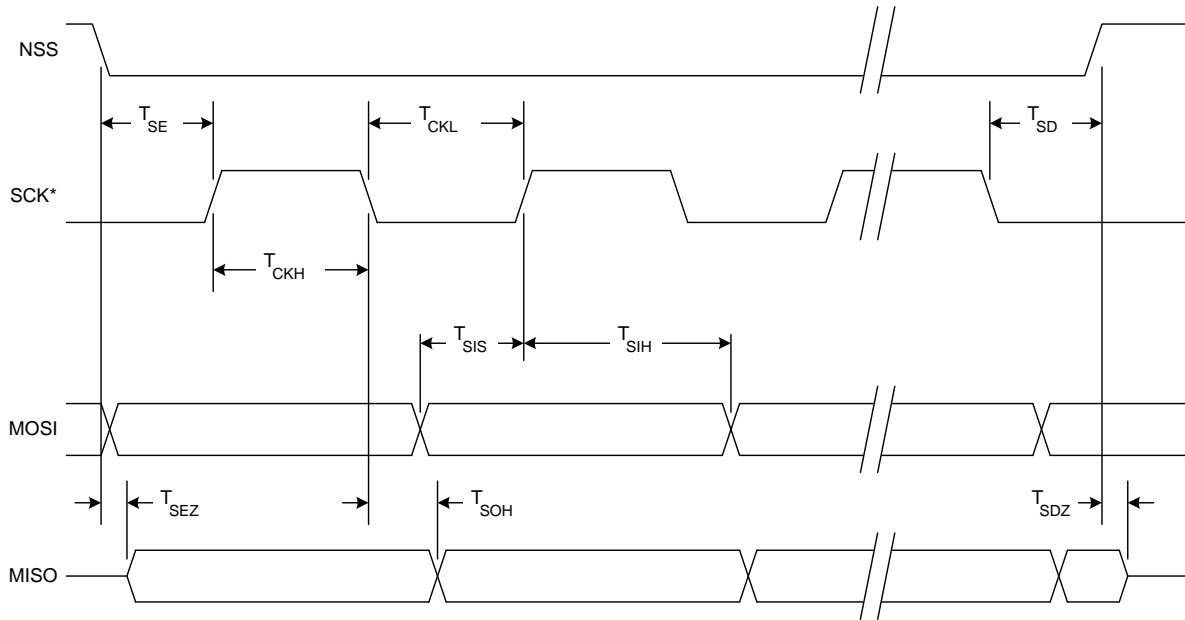

* SCK is shown for CKPOL = 0. SCK is the opposite polarity for CKPOL = 1.

Figure 30.10. SPI Slave Timing (CKPHA = 0)

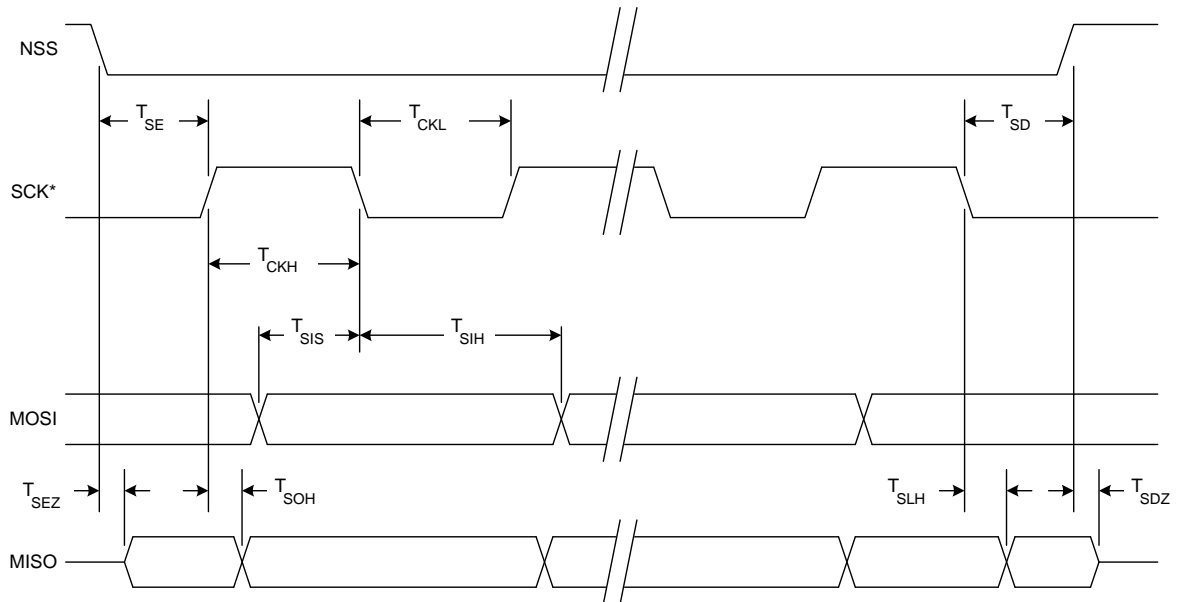

* SCK is shown for CKPOL = 0. SCK is the opposite polarity for CKPOL = 1.

Figure 30.11. SPI Slave Timing (CKPHA = 1)

Si102x/3x

Table 30.1. SPI Slave Timing Parameters

Parameter	Description	Min	Max	Units
Master Mode Timing (See Figure 30.8 and Figure 30.9)				
T_{MCKH}	SCK High Time	$1 \times T_{SYSCLK}$	—	ns
T_{MCKL}	SCK Low Time	$1 \times T_{SYSCLK}$	—	ns
T_{MIS}	MISO Valid to SCK Shift Edge	$1 \times T_{SYSCLK} + 20$	—	ns
T_{MIH}	SCK Shift Edge to MISO Change	0	—	ns
Slave Mode Timing (See Figure 30.10 and Figure 30.11)				
T_{SE}	NSS Falling to First SCK Edge	$2 \times T_{SYSCLK}$	—	ns
T_{SD}	Last SCK Edge to NSS Rising	$2 \times T_{SYSCLK}$	—	ns
T_{SEZ}	NSS Falling to MISO Valid	—	$4 \times T_{SYSCLK}$	ns
T_{SDZ}	NSS Rising to MISO High-Z	—	$4 \times T_{SYSCLK}$	ns
T_{CKH}	SCK High Time	$5 \times T_{SYSCLK}$	—	ns
T_{CKL}	SCK Low Time	$5 \times T_{SYSCLK}$	—	ns
T_{SIS}	MOSI Valid to SCK Sample Edge	$2 \times T_{SYSCLK}$	—	ns
T_{SIH}	SCK Sample Edge to MOSI Change	$2 \times T_{SYSCLK}$	—	ns
T_{SOH}	SCK Shift Edge to MISO Change	—	$4 \times T_{SYSCLK}$	ns
T_{SLH}	Last SCK Edge to MISO Change (CKPHA = 1 ONLY)	$6 \times T_{SYSCLK}$	$8 \times T_{SYSCLK}$	ns
Note: T_{SYSCLK} is equal to one period of the device system clock (SYSCLK).				

31. EZRadioPRO[®] Serial Interface

The EZRadioPRO serial interface (SPI1) provides access to the EZRadioPRO peripheral registers from software executing on the MCU core. The serial interface consists of two SPI peripherals: a dedicated SPI Master accessible from the MCU core and a dedicated SPI Slave residing inside the EZRadioPRO peripheral. The SPI1 peripheral on the MCU core side can only be used in master mode to communicate with the EZRadioPRO slave device in three-wire mode. NSS for the EZRadioPRO is provided using Port 2.3, which is internally routed to the EZRadioPRO peripheral.

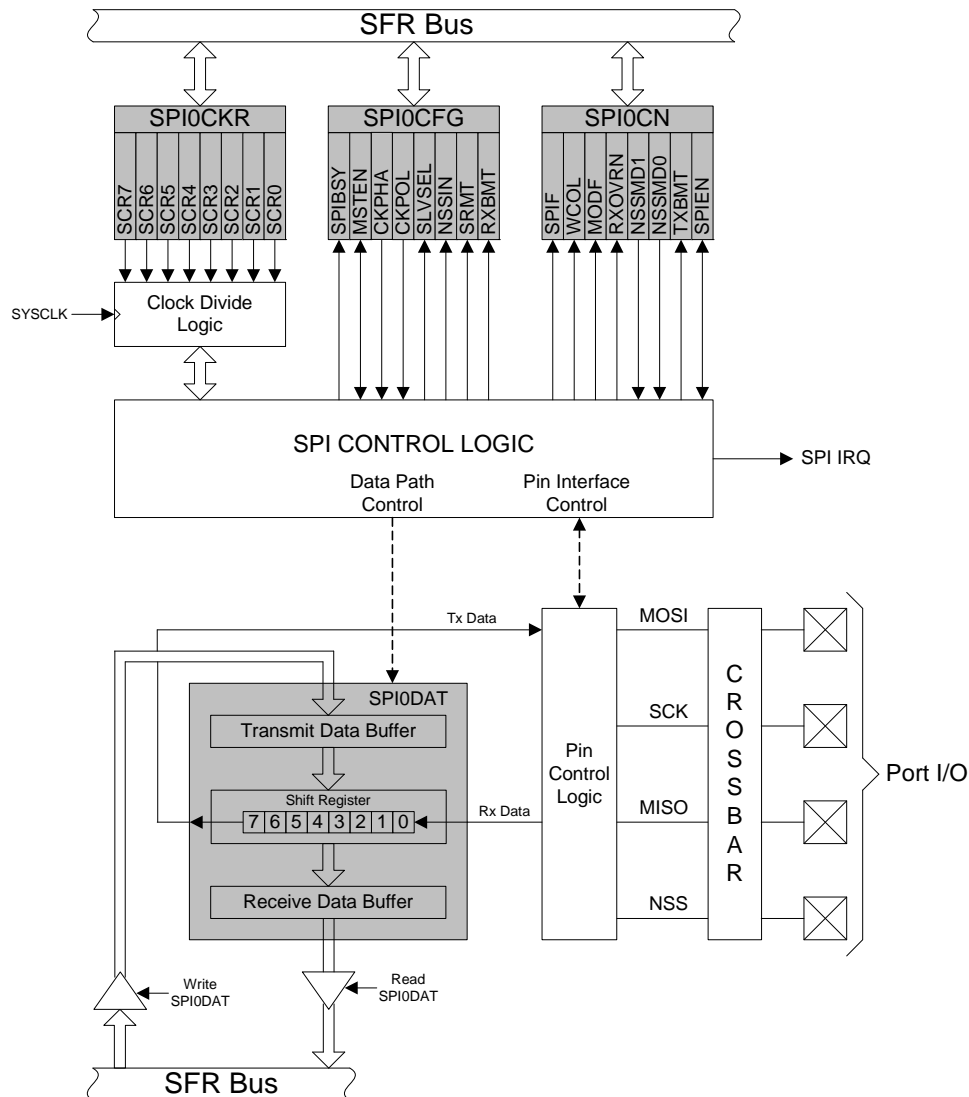

Figure 31.1. SPI Block Diagram

Si102x/3x

31.1. Signal Descriptions

The four signals used by SPI1 (MOSI, MISO, SCK, NSS) are described below.

31.1.1. Master Out, Slave In (MOSI)

The master-out, slave-in (MOSI) signal is an output from a master device and an input to slave devices. It is used to serially transfer data from the master to the slave. This signal is an output to the MCU core. Data is transferred most-significant bit first. MOSI is driven by the MSB of the shift register.

31.1.2. Master In, Slave Out (MISO)

The master-in, slave-out (MISO) signal is an output from a slave device and an input to the master device. It is used to serially transfer data from the EZRadioPRO to the MCU core. This signal is an input when SPI1 is operating as a master and an output when SPI1 is operating as a slave. Data is transferred most-significant bit first. The MISO pin is placed in a high-impedance state when the SPI1 module is disabled.

31.1.3. Serial Clock (SCK)

The serial clock (SCK) signal is an output from the master device and an input to the EZRadioPRO. It is used to synchronize the transfer of data between the master and slave on the MOSI and MISO lines. SPI1 generates this signal.

31.1.4. Slave Select (NSS)

To interface to the EZRadioPRO, SPI1 operates in three-wire mode. The NSS functionality built into the SPI state machine is not used. Instead, the port pin P2.3 must be configured to control the chip select on the EZRadioPRO peripheral under software control.

31.2. SPI1 Master Mode Operation

A SPI master device initiates all data transfers on a SPI bus. SPI1 is placed in master mode by setting the Master Enable flag (MSTEN, SPI1CN.6). Writing a byte of data to the SPI1 data register (SPI1DAT) when in master mode writes to the transmit buffer. If the SPI shift register is empty, the byte in the transmit buffer is moved to the shift register, and a data transfer begins. The SPI1 master immediately shifts out the data serially on the MOSI line while providing the serial clock on SCK. The SPIF (SPI1CN.7) flag is set to logic 1 at the end of the transfer. If interrupts are enabled, an interrupt request is generated when the SPIF flag is set. While the SPI1 master transfers data to a slave on the MOSI line, the addressed SPI slave device simultaneously transfers the contents of its shift register to the SPI master on the MISO line in a full-duplex operation. Therefore, the SPIF flag serves as both a transmit-complete and receive-data-ready flag. The data byte received from the slave is transferred MSB-first into the master's shift register. When a byte is fully shifted into the register, it is moved to the receive buffer where it can be read by the processor by reading SPI1DAT.

31.3. SPI Slave Operation on the EZRadioPRO Peripheral Side

The EZRadioPRO peripheral presents a standard 4-wire SPI interface: SCK, MISO, MOSI, and NSS. The SPI master can read data from the device on the MOSI output pin. An SPI transaction is a 16-bit sequence that consists of a Read-Write (R/W) select bit followed by a 7-bit address field (ADDR) and an 8-bit data field (DATA), as demonstrated in Figure 31.2. The 7-bit address field is used to select one of the 128, 8-bit control registers. The R/W select bit determines whether the SPI transaction is a read or write transaction. If R/W = 1, it signifies a WRITE transaction, while R/W = 0 signifies a READ transaction. The contents (ADDR or DATA) are latched into the transceiver every eight clock cycles. The timing parameters for the SPI interface are shown in Table 31.1. The SCK rate is flexible with a maximum rate of 10 MHz.

31.4. SPI1 Interrupt Sources

When SPI1 interrupts are enabled, the following four flags will generate an interrupt when they are set to logic 1:

All of the following bits must be cleared by software.

- The SPI Interrupt Flag, SPIF (SPI1CN.7) is set to logic 1 at the end of each byte transfer. This flag can occur in all SPI1 modes.
- The Write Collision Flag, WCOL (SPI1CN.6) is set to logic 1 if a write to SPI1DAT is attempted when the transmit buffer has not been emptied to the SPI shift register. When this occurs, the write to SPI1DAT will be ignored, and the transmit buffer will not be written. This flag can occur in all SPI1 modes.
- The Mode Fault Flag MODF (SPI1CN.5) is set to logic 1 when SPI1 is configured as a master, and for multi-master mode and the NSS pin is pulled low. When a Mode Fault occurs, the MSTEN and SPIEN bits in SPI1CN are set to logic 0 to disable SPI1 and allow another master device to access the bus.
- The Receive Overrun Flag RXOVRN (SPI1CN.4) is set to logic 1 when configured as a slave, and a transfer is completed and the receive buffer still holds an unread byte from a previous transfer. The new byte is not transferred to the receive buffer, allowing the previously received data byte to be read. The data byte which caused the overrun is lost.

31.5. Serial Clock Phase and Polarity

Four combinations of serial clock phase and polarity can be selected using the clock control bits in the SPI Configuration Register (SPI1CFG). The CKPHA bit (SPI1CFG.5) selects one of two clock phases (edge used to latch the data). The CKPOL bit (SPI1CFG.4) selects between an active-high or active-low clock. Both CKPOL and CKPHA must be set to zero in order to communicate with the EZRadioPRO peripheral. The SPI1 Clock Rate Register (SPI1CKR), as shown in SFR Definition 31.3, controls the master mode serial clock frequency. When the SPI is configured as a master, the maximum data transfer rate (bits/sec) is one-half the system clock frequency or 12.5 MHz, whichever is slower.

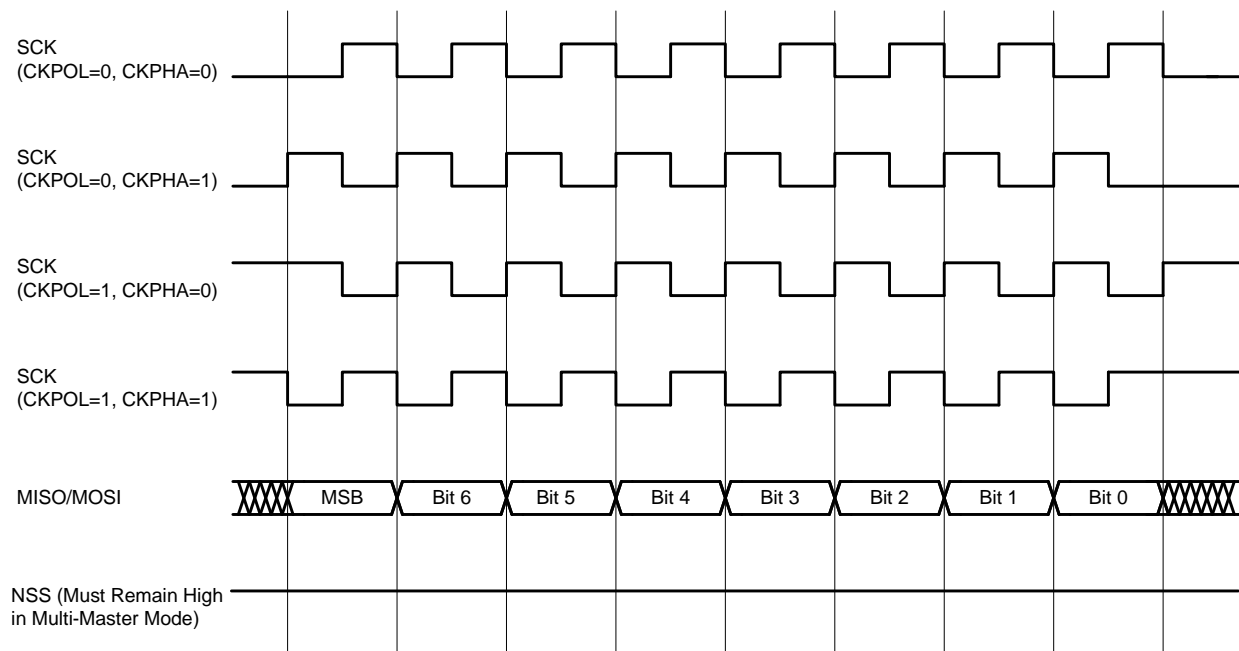

Figure 31.2. Master Mode Data/Clock Timing

31.6. Using SPI1 with the DMA

SPI1 is a DMA-enabled peripheral that can provide autonomous data transfers when used with the DMA. The SPI requires two DMA channels for a bidirectional data transfer and also supports unidirectional data transfers using a single DMA channel.

There are no additional control bits in the SPI1 control and configuration SFRs. The configuration is the same in DMA and non-DMA mode. While the SPIF flag and/or SPI interrupts are normally used for non-DMA SPI transfers, a DMA transfer is managed using the DMA enable and DMA full transfer complete flags.

More information on using the SPI1 peripheral with DMA can be found in the detailed example code for EZRadioPRO.

31.7. Master Mode SPI1 DMA Transfers

The SPI interface does not normally have any handshaking or flow control. Therefore, the Master will transmit all of the output data without waiting on the slave peripheral. The system designer must ensure that the slave peripheral can accept all of the data at the transfer rate.

31.8. Master Mode Bidirectional Data Transfer

A bidirectional SPI Master Mode DMA transfer will transmit a specified number of bytes out on the MOSI pin and receive the same number of bytes on the MISO pin. The MOSI data must be stored in XRAM before initiating the DMA transfers. The DMA will also transfer all the MISO data to XRAM, overwriting any data at the target location.

A bidirectional transfer requires two DMA channels. The first DMA channel transfers data from XRAM to the SPI1DAT SFR and the second DMA channel transfers data from the SPI1DAT SFR to XRAM. The second channel DMA interrupt indicates SPI transfer completion.

The NSS pin is an output, and the hardware does not manage the NSS pin automatically. Firmware should assert the NSS pin before the SPI transfer and deassert it upon completion of the transfer.

To initiate a Master mode Bidirectional data transfer:

1. Configure the SPI1 SFRs normally for Master mode.
 - a. Enable Master mode by setting bit 6 in SPI1CFG.
 - b. Configure the clock polarity (CKPOL = 0) and clock phase (CKPHA = 0) as desired in SPI1CFG.
 - c. Configure SPI1CKR for the desired SPI clock rate.
 - d. Configure 3-wire master mode in SPI1CN.
 - e. Enable the SPI by setting bit 0 of SPI1CN.
2. Configure the first DMA channel for the XRAM-to-SPI1DATA transfer:
 - a. Disable the first DMA channel by clearing the corresponding bit in DMA0EN.
 - b. Select the first DMA channel by writing to DMA0SEL.
 - c. Configure the selected DMA channel to use the XRAM-to-SPI1DAT peripheral request by writing 0x03 to DMA0NCF.
 - d. Write 0 to DMA0NMD to disable wrapping.
 - e. Write the address of the first byte of master output (MOSI) data to DMA0NBAH:L.
 - f. Write the size of the SPI transfer in bytes to DMA0NSZH:L.
 - g. Clear the address offset SFRs CMA0A0H:L.
3. Configure the second DMA channel for the SPI1DAT-to-XRAM transfer:
 - a. Disable the second DMA channel by clearing the corresponding bit in DMA0EN.

- b. Select the second DMA channel by writing to DMA0SEL.
 - c. Configure the selected DMA channel to use the SPI1DAT-to-XRAM peripheral request by writing 0x04 to DMA0NCF.
 - d. Enable DMA interrupts for the second channel by setting bit 7 of DMA0NCF.
 - e. Write 0 to DMA0NMD to disable wrapping.
 - f. Write the address for the first byte of master input (MISO) data to DMA0NBAH:L.
 - g. Write the size of the SPI transfer in bytes to DMA0NSZH:L.
 - h. Clear the address offset SFRs CMA0A0H:L.
 - i. Enable the interrupt on the second channel by setting the corresponding bit in DMA0INT.
 - j. Enable DMA interrupts by setting bit 5 of EIE2.
4. Clear the interrupt bits in DMA0INT for both channels.
 5. Enable both channels by setting the corresponding bits in the DMA0EN SFR to initiate the SPI transfer operation.
 6. Wait on the DMA interrupt.
 7. Clear the DMA enables in the DMA0EN SFR.
 8. Clear the DMA interrupts in the DMA0INT SFR.

31.9. Master Mode Unidirectional Data Transfer

A unidirectional SPI master mode DMA transfer will transfer a specified number of bytes out on the MOSI pin. The MOSI data must be stored in XRAM before initiating the DMA transfers. The SPI1DAT-to-XRAM peripheral request is not used. Since the DMA does not read the SPI1DAT SFR, the SPI will discard the MISO data.

A unidirectional transfer only requires one DMA channel to transfer XRAM data to the SPI1DAT SFR. The DMA interrupt will indicate the completion of the data transfer to the SPI1DAT SFR. When the interrupt occurs, the DMA has written all of the data to the SPI1DAT SFR, but the SPI has not transmitted the last byte. Firmware may poll on the SPIBSY bit to determine when the SPI has transmitted the last byte. Firmware should not deassert the NSS pin until after the SPI has transmitted the last byte.

To initiate a master mode unidirectional data transfer:

1. Configure the SPI1 SFRs normally for Master mode.
 - a. Enable Master mode by setting bit 6 in SPI1CFG.
 - b. Configure the clock polarity (CKPOL = 0) and clock phase (CKPHA = 0) as desired in SPI1CFG.
 - c. Configure SPI1CKR for the desired SPI clock rate.
 - d. Configure 3-wire master mode in SPI1CN.
 - e. Enable the SPI by setting bit 0 of SPI1CN.
2. Configure the desired DMA channel for the XRAM-to-SPI1DAT transfer.
 - a. Disable the desired DMA channel by clearing the corresponding bit in DMA0EN.
 - b. Select the desired DMA channel by writing to DMA0SEL.
 - c. Configure the selected DMA channel to use the XRAM-to-SPI1DAT XRAM peripheral request by writing 0x03 to DMA0NCF.
 - d. Enable DMA interrupts for the desired channel by setting bit 7 of DMA0NCF.
 - e. Write 0 to DMA0NMD to disable wrapping.
 - f. Write the address for the first byte of master output (MOSI) data to DMA0NBAH:L.
 - g. Write the size of the SPI transfer in bytes to DMA0NSZH:L.
 - h. Clear the address offset SFRs DMA0A0H:L.
 - i. Enable the interrupt on the desired channel by setting the corresponding bit in DMA0INT.
 - j. Enable DMA interrupts by setting bit 5 of EIE2.
3. Clear the interrupt bit in DMA0INT for the desired channel.
4. Enable the desired channel by setting the corresponding bit in the DMA0EN SFR to initiate the SPI transfer operation.
5. Wait on the DMA interrupt.
6. Clear the DMA enables in the DMA0EN SFR.
7. Clear the DMA interrupts in the DMA0INT SFR.
8. If desired, wait on the SPIBSY bit in SPI1CFG for the last byte transfer to complete.

31.10. SPI Special Function Registers

SPI1 is accessed and controlled through four special function registers in the system controller: SPI1CN Control Register, SPI1DAT Data Register, SPI1CFG Configuration Register, and SPI1CKR Clock Rate Register. The four special function registers related to the operation of the SPI1 Bus are described in the following SFR definitions.

Si102x/3x

SFR Definition 31.1. SPI1CFG: SPI1 Configuration

Bit	7	6	5	4	3	2	1	0
Name	SPIBSY	MSTEN	CKPHA	CKPOL				
Type	R	R/W	R/W	R/W	R	R	R	R
Reset	0	0	0	0	0	1	1	1

SFR Page = 0x2; SFR Address = 0xA1

Bit	Name	Function
7	SPIBSY	SPI Busy. This bit is set to logic 1 when a SPI transfer is in progress (master or slave mode).
6	MSTEN	Master Mode Enable. When set to “1”, enables master mode. This bit must be set to 1 to communicate with the EZRadioPRO peripheral.
5	CKPHA	SPI1 Clock Phase. 0: Data centered on first edge of SCK period.* 1: Data centered on second edge of SCK period.*
4	CKPOL	SPI1 Clock Polarity. 0: SCK line low in idle state. 1: SCK line high in idle state.
3:0		Reserved. Read = 0111, Write = Don't care.

Note: In master mode, data on MISO is sampled one SYSCLK before the end of each data bit, to provide maximum settling time for the slave device. See Table 31.1 for timing parameters.

SFR Definition 31.2. SPI1CN: SPI1 Control

Bit	7	6	5	4	3	2	1	0
Name	SPIF	WCOL	MODF		NSSMD[1:0]		TXBMT	SPIEN
Type	R/W	R/W	R/W	R/W	R/W		R	R/W
Reset	0	0	0	0	0	1	1	0

SFR Page = 0x2; SFR Address = 0xF8; Bit-Addressable

Bit	Name	Function
7	SPIF	SPI1 Interrupt Flag. This bit is set to logic 1 by hardware at the end of a data transfer. If SPI interrupts are enabled, an interrupt will be generated. This bit is not automatically cleared by hardware, and must be cleared by software.
6	WCOL	Write Collision Flag. This bit is set to logic 1 if a write to SPI1DAT is attempted when TXBMT is 0. When this occurs, the write to SPI1DAT will be ignored, and the transmit buffer will not be written. If SPI interrupts are enabled, an interrupt will be generated. This bit is not automatically cleared by hardware, and must be cleared by software.
5	MODF	Mode Fault Flag. This bit is set to logic 1 by hardware when a master mode collision is detected (NSS is low, MSTEN = 1, and NSSMD[1:0] = 01). If SPI interrupts are enabled, an interrupt will be generated. This bit is not automatically cleared by hardware, and must be cleared by software.
4		Reserved. Read = Varies; Write = 0.
3:2	NSSMD[1:0]	Slave Select Mode. Must be set to 00b. SPI1 can only be used in 3-wire master mode.
1	TXBMT	Transmit Buffer Empty. This bit will be set to logic 0 when new data has been written to the transmit buffer. When data in the transmit buffer is transferred to the SPI shift register, this bit will be set to logic 1, indicating that it is safe to write a new byte to the transmit buffer.
0	SPIEN	SPI1 Enable. 0: SPI disabled. 1: SPI enabled.

Si102x/3x

SFR Definition 31.3. SPI1CKR: SPI1 Clock Rate

Bit	7	6	5	4	3	2	1	0
Name	SCR[7:0]							
Type	R/W							
Reset	0	0	0	0	0	0	0	0

SFR Page = 0x2; SFR Address = 0xA2

Bit	Name	Function
7:0	SCR[7:0]	<p>SPI1 Clock Rate.</p> <p>These bits determine the frequency of the SCK output when the SPI1 module is configured for master mode operation. The SCK clock frequency is a divided version of the system clock, and is given in the following equation, where <i>SYCLK</i> is the system clock frequency and <i>SPI1CKR</i> is the 8-bit value held in the SPI1CKR register.</p> $f_{SCK} = \frac{SYCLK}{2 \times (SPI1CKR[7:0] + 1)}$ <p>for $0 \leq SPI1CKR \leq 255$</p> <p>Example: If <i>SYCLK</i> = 2 MHz and <i>SPI1CKR</i> = 0x04,</p> $f_{SCK} = \frac{2000000}{2 \times (4 + 1)}$ $f_{SCK} = 200kHz$

SFR Definition 31.4. SPI1DAT: SPI1 Data

Bit	7	6	5	4	3	2	1	0
Name	SPI1DAT[7:0]							
Type	R/W							
Reset	0	0	0	0	0	0	0	0

SFR Page = 0x2; SFR Address = 0xA3

Bit	Name	Function
7:0	SPI1DAT[7:0]	<p>SPI1 Transmit and Receive Data.</p> <p>The SPI1DAT register is used to transmit and receive SPI1 data. Writing data to SPI1DAT places the data into the transmit buffer and initiates a transfer when in Master Mode. A read of SPI1DAT returns the contents of the receive buffer.</p>

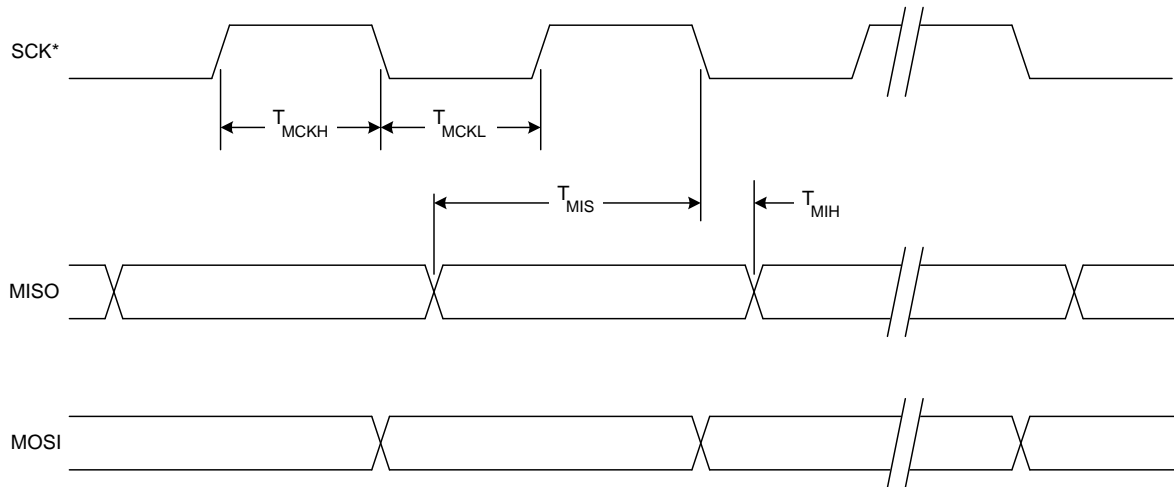

* SCK is shown for CKPOL = 0. SCK is the opposite polarity for CKPOL = 1.

Figure 31.3. SPI Master Timing (CKPHA = 0)

Table 31.1. SPI Timing Parameters

Parameter	Description	Min	Max	Units
Master Mode Timing (See Figure 31.3)				
T_{MCKH}	SCK High Time	$1 \times T_{SYSCLK}$	—	ns
T_{MCKL}	SCK Low Time	$1 \times T_{SYSCLK}$	—	ns
T_{MIS}	MISO Valid to SCK Shift Edge	$1 \times T_{SYSCLK} + 20$	—	ns
T_{MIH}	SCK Shift Edge to MISO Change	0	—	ns
Note: T_{SYSCLK} is equal to one period of the device system clock (SYSCLK).				

Si102x/3x



32. EZRadioPRO[®] 240–960 MHz Transceiver

Si102x/3x devices include the EZRadioPRO family of ISM wireless transceivers with continuous frequency tuning over 240–960 MHz. The wide operating voltage range of 1.8–3.6 V and low current consumption makes the EZRadioPRO an ideal solution for battery powered applications.

The EZRadioPRO transceiver operates as a time division duplexing (TDD) transceiver where the device alternately transmits and receives data packets. The device uses a single-conversion mixer to downconvert the 2-level FSK/GFSK/OOK modulated receive signal to a low IF frequency. Following a programmable gain amplifier (PGA) the signal is converted to the digital domain by a high performance $\Delta\Sigma$ ADC allowing filtering, demodulation, slicing, and packet handling to be performed in the built-in DSP increasing the receiver's performance and flexibility versus analog based architectures. The demodulated signal is then output to the system MCU through a programmable GPIO or via the standard SPI bus by reading the 64-byte RX FIFO.

A single high precision local oscillator (LO) is used for both transmit and receive modes since the transmitter and receiver do not operate at the same time. The LO is generated by an integrated VCO and $\Delta\Sigma$ Fractional-N PLL synthesizer. The synthesizer is designed to support configurable data rates, output frequency and frequency deviation at any frequency between 240–960 MHz. The transmit FSK data is modulated directly into the $\Delta\Sigma$ data stream and can be shaped by a Gaussian low-pass filter to reduce unwanted spectral content.

The PA output power of the Si1020/21/22/23/30/31/32/33 devices can be configured between –1 and +20 dBm in 3 dB steps, while the PA output power of the Si1024/25/26/27/34/35/36/37 devices can be configured between –8 and +13 dBm in 3 dB steps. The PA is single-ended to allow for easy antenna matching and low BOM cost. The PA incorporates automatic ramp-up and rampdown control to reduce unwanted spectral spreading. The devices with +20 dBm output power can also be used to compensate for the reduced performance of a lower cost, lower performance antenna or antenna with size constraints due to a small form-factor. Competing solutions require large and expensive external PAs to achieve comparable performance. The EZRadioPRO transceivers support frequency hopping, TX/RX switch control, and antenna diversity switch control to extend the link range and improve performance.

The EZRadioPRO peripheral also controls three GPIO pins: GPIO_0, GPIO_1, and GPIO_2. See Application Note “AN415: EZRadioPRO Programming Guide” for details on initializing and using the EZRadioPRO peripheral.

Si102x/3x

32.1. EZRadioPRO Operating Modes

The EZRadioPRO transceivers provide several operating modes which can be used to optimize the power consumption for a given application. Depending upon the system communication protocol, an optimal trade-off between the radio wake time and power consumption can be achieved.

Table 32.1 summarizes the operating modes of the EZRadioPRO transceivers. In general, any given operating mode may be classified as an active mode or a power saving mode. The table indicates which block(s) are enabled (active) in each corresponding mode. With the exception of the SHUTDOWN mode, all can be dynamically selected by sending the appropriate commands over the SPI. An “X” in any cell means that, in the given mode of operation, that block can be independently programmed to be either ON or OFF, without noticeably impacting the current consumption. The SPI circuit block includes the SPI interface hardware and the device register space. The 32 kHz OSC block includes the 32.768 kHz RC oscillator or 32.768 kHz crystal oscillator and wake-up timer. AUX (Auxiliary Blocks) includes the temperature sensor, general purpose ADC, and low-battery detector.

Table 32.1. EZRadioPRO Operating Modes

Mode Name	Circuit Blocks								I _{VDD}
	Digital LDO	SPI	32 kHz OSC	AUX	30 MHz XTAL	PLL	PA	RX	
SHUT-DOWN	OFF (Register contents lost)	OFF	OFF	OFF	OFF	OFF	OFF	OFF	15 nA
STANDBY	ON (Register contents retained)	ON	OFF	OFF	OFF	OFF	OFF	OFF	450 nA
SLEEP		ON	ON	X	OFF	OFF	OFF	OFF	1 μA
SENSOR		ON	X	ON	OFF	OFF	OFF	OFF	1 μA
READY		ON	X	X	ON	OFF	OFF	OFF	600 μA
TUNING		ON	X	X	ON	ON	OFF	OFF	8.5 mA
TRANSMIT		ON	X	X	ON	ON	ON	OFF	30 mA*
RECEIVE		ON	X	X	ON	ON	OFF	ON	18.5 mA

Note: Using Si1024/25/26/27/34/35/36/37 at +13 dBm with recommended reference design. These power modes are for the EZRadioPRO peripheral only and are independent of the MCU power modes.

32.1.1. Operating Mode Control

There are four primary states in the EZRadioPRO transceiver radio state machine: SHUTDOWN, IDLE, TX, and RX (see Figure 32.1). The SHUTDOWN state completely shuts down the radio to minimize current consumption. There are five different configurations/options for the IDLE state which can be selected to optimize the chip for the application. "Register 07h. Operating Mode and Function Control 1" controls which operating mode/state is selected with the exception of SHUTDOWN which is controlled by the SDN pin. The TX and RX state may be reached automatically from any of the IDLE states by setting the txon/rxon bits in "Register 07h. Operating Mode and Function Control 1". Table 32.2 shows each of the operating modes with the time required to reach either RX or TX mode as well as the current consumption of each mode.

The transceivers include a low-power digital regulated supply (LPLDO) which is internally connected in parallel to the output of the main digital regulator (and is available externally at the VR_DIG pin). This common digital supply voltage is connected to all digital circuit blocks including the digital modem, crystal oscillator, SPI, and register space. The LPLDO has extremely low quiescent current consumption but limited current supply capability; it is used only in the IDLE-STANDBY and IDLE-SLEEP modes. The main digital regulator is automatically enabled in all other modes.

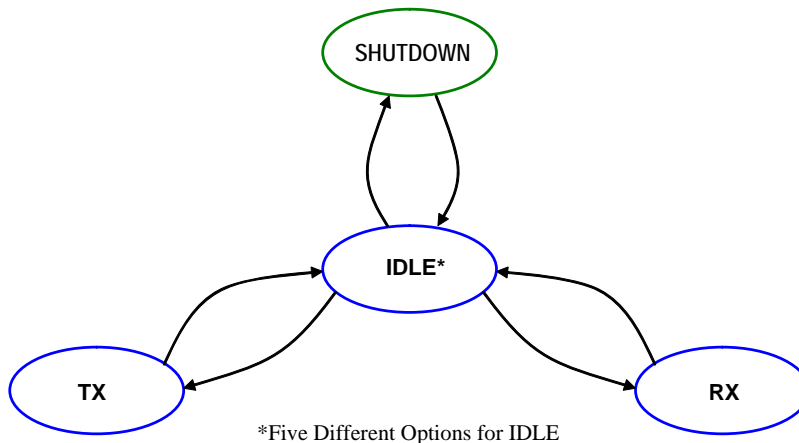

Figure 32.1. State Machine Diagram

Table 32.2. EZRadioPRO Operating Modes Response Time

State/Mode	Response Time to		Current in State /Mode [μ A]
	TX	RX	
Shut Down State	16.8 ms	16.8 ms	15 nA
Idle States:			
Standby Mode	800 μ s	800 μ s	450 nA
Sleep Mode	800 μ s	800 μ s	1 μ A
Sensor Mode	800 μ s	800 μ s	1 μ A
Ready Mode	200 μ s	200 μ s	800 μ A
Tune Mode	200 μ s	200 μ s	8.5 mA
TX State	NA	200 μ s	30 mA @ +13 dBm
RX State	200 μ s	NA	18.5 mA

32.1.1.1. SHUTDOWN State

The SHUTDOWN state is the lowest current consumption state of the device with nominally less than 15 nA of current consumption. The shutdown state may be entered by driving the SDN pin high. The SDN pin should be held low in all states except the SHUTDOWN state. In the SHUTDOWN state, the contents of the registers are lost and there is no SPI access.

When the chip is connected to the power supply, a POR will be initiated after the falling edge of SDN. After a POR, the device will be in READY mode with the buffers enabled.

32.1.1.1.1. IDLE State

There are five different modes in the IDLE state which may be selected by "Register 07h. Operating Mode and Function Control 1". All modes have a tradeoff between current consumption and response time to TX/RX mode. This tradeoff is shown in Table 32.2. After the POR event, SWRESET, or exiting from the SHUTDOWN state the chip will default to the IDLE-READY mode. After a POR event the interrupt registers must be read to properly enter the SLEEP, SENSOR, or STANDBY mode and to control the 32 kHz clock correctly.

32.1.1.1.2. STANDBY Mode

STANDBY mode has the lowest current consumption of the five IDLE states with only the LPLDO enabled to maintain the register values. In this mode the registers can be accessed in both read and write mode. The STANDBY mode can be entered by writing 0h to "Register 07h. Operating Mode and Function Control 1". If an interrupt has occurred (i.e., the nIRQ pin = 0) the interrupt registers must be read to achieve the minimum current consumption. Additionally, the ADC should not be selected as an input to the GPIO in this mode as it will cause excess current consumption.

32.1.1.1.3. SLEEP Mode

In SLEEP mode the LPLDO is enabled along with the Wake-Up-Timer, which can be used to accurately wake-up the radio at specified intervals. See "Wake-Up Timer and 32 kHz Clock Source" on page 479 for more information on the Wake-Up-Timer. SLEEP mode is entered by setting `enwt = 1` (40h) in "Register 07h. Operating Mode and Function Control 1". If an interrupt has occurred (i.e., the nIRQ pin = 0) the interrupt registers must be read to achieve the minimum current consumption. Also, the ADC should not be selected as an input to the GPIO in this mode as it will cause excess current consumption.

32.1.1.1.4. SENSOR Mode

In SENSOR mode either the Low Battery Detector, Temperature Sensor, or both may be enabled in addition to the LPLDO and Wake-Up-Timer. The Low Battery Detector can be enabled by setting `enlbd = 1` in "Register 07h. Operating Mode and Function Control 1". See "Temperature Sensor" on page 476 and "Low Battery Detector" on page 478 for more information on these features. If an interrupt has occurred (i.e., the nIRQ pin = 0) the interrupt registers must be read to achieve the minimum current consumption.

32.1.1.1.5. READY Mode

READY Mode is designed to give a fast transition time to TX mode with reasonable current consumption. In this mode the Crystal oscillator remains enabled reducing the time required to switch to TX or RX mode by eliminating the crystal start-up time. READY mode is entered by setting `xton = 1` in "Register 07h. Operating Mode and Function Control 1". To achieve the lowest current consumption state the crystal oscillator buffer should be disabled in "Register 62h. Crystal Oscillator Control and Test." To exit READY mode, `bufovr` (bit 1) of this register must be set back to 0.

32.1.1.1.6. TUNE Mode

In TUNE mode the PLL remains enabled in addition to the other blocks enabled in the IDLE modes. This will give the fastest response to TX mode as the PLL will remain locked but it results in the highest current consumption. This mode of operation is designed for frequency hopping spread spectrum systems (FHSS). TUNE mode is entered by setting `pilon = 1` in "Register 07h. Operating Mode and Function Control 1". It is not necessary to set `xton` to 1 for this mode, the internal state machine automatically enables the crystal oscillator.

32.1.1.2. TX State

The TX state may be entered from any of the IDLE modes when the txon bit is set to 1 in "Register 07h. Operating Mode and Function Control 1". A built-in sequencer takes care of all the actions required to transition between states from enabling the crystal oscillator to ramping up the PA. The following sequence of events will occur automatically when going from STANDBY mode to TX mode by setting the txon bit.

1. Enable the main digital LDO and the Analog LDOs.
2. Start up crystal oscillator and wait until ready (controlled by an internal timer).
3. Enable PLL.
4. Calibrate VCO (this action is skipped when the skipvco bit is 1, default value is 0).
5. Wait until PLL settles to required transmit frequency (controlled by an internal timer).
6. Activate power amplifier and wait until power ramping is completed (controlled by an internal timer).
7. Transmit packet.

Steps in this sequence may be eliminated depending on which IDLE mode the chip is configured to prior to setting the txon bit. By default, the VCO and PLL are calibrated every time the PLL is enabled.

32.1.1.3. RX State

The RX state may be entered from any of the IDLE modes when the rxon bit is set to 1 in "Register 07h. Operating Mode and Function Control 1". A built-in sequencer takes care of all the actions required to transition from one of the IDLE modes to the RX state. The following sequence of events will occur automatically to get the chip into RX mode when going from STANDBY mode to RX mode by setting the rxon bit:

1. Enable the main digital LDO and the Analog LDOs.
2. Start up crystal oscillator and wait until ready (controlled by an internal timer).
3. Enable PLL.
4. Calibrate VCO (this action is skipped when the skipvco bit is 1, default value is 0).
5. Wait until PLL settles to required receive frequency (controlled by an internal timer).
6. Enable receive circuits: LNA, mixers, and ADC.
7. Enable receive mode in the digital modem.

Depending on the configuration of the radio all or some of the following functions will be performed automatically by the digital modem: AGC, AFC (optional), update status registers, bit synchronization, packet handling (optional) including sync word, header check, and CRC.

32.1.1.4. Device Status

Add	R/W	Function/ Description	D7	D6	D5	D4	D3	D2	D1	D0	POR Def.
02	R	Device Status	ffovfl	ffunfl	rxffem	headerr	freqerr		cps[1]	cps[0]	—

The operational status of the EZRadioPRO peripheral can be read from "Register 02h. Device Status".

32.2. Interrupts

The EZRadioPRO peripheral is capable of generating an interrupt signal (nIRQ) when certain events occur. The nIRQ pin is driven low to indicate a pending interrupt request. **The EZRadioPRO interrupt does not have an internal interrupt vector. To use the interrupt, the nIRQ pin must be looped back to an external interrupt input.** This interrupt signal will be generated when any one (or more) of the interrupt events (corresponding to the Interrupt Status bits) shown below occur. The nIRQ pin will remain low until the Interrupt Status Register(s) (Registers 03h–04h) containing the active Interrupt Status bit is read. The nIRQ output signal will then be reset until the next change in status is detected. The interrupts must be

Si102x/3x

enabled by the corresponding enable bit in the Interrupt Enable Registers (Registers 05h–06h). All enabled interrupt bits will be cleared when the corresponding interrupt status register is read. If the interrupt is not enabled when the event occurs it will not trigger the nIRQ pin, but the status may still be read at anytime in the Interrupt Status registers.

Important Note: The nIRQ line should not be monitored for POR after SDN or initial power up. The POR signal is available by default on GPIO0 and GPIO1 and should be monitored as an alternative to nIRQ for POR. As an alternative, software may wait 18 ms after SDN rising before polling the interrupt status registers in 03h and 04h to check for POR and chip ready (XTAL start-up/ready). This process may take up to 26 ms. After the initial interrupt is cleared, the operation of the nIRQ pin will be normal.

Add	R/W	Function/Description	D7	D6	D5	D4	D3	D2	D1	D0	POR Def.
03	R	Interrupt Status 1	ifferr	itxffafull	itxffaem	irxffafull	iext	ipksent	ipkvalid	icrcerror	—
04	R	Interrupt Status 2	iswdet	ipreaval	ipreainval	irssi	iwut	ilbd	ichiprdy	ipor	—
05	R/W	Interrupt Enable 1	enferr	entxffafull	entxffaem	enrxffafull	enext	enpksent	enpvalid	encrcerror	00h
06	R/W	Interrupt Enable 2	enswdet	enpreava	enpreainval	enrssi	enwut	enlbd	enchiprdy	enpor	01h

See “AN440: EZRadioPRO Detailed Register Descriptions” for a complete list of interrupts.

32.3. System Timing

The system timing for TX and RX modes is shown in Figures 32.2 and 32.3. The figures demonstrate transitioning from STANDBY mode to TX or RX mode through the built-in sequencer of required steps. The user only needs to program the desired mode, and the internal sequencer will properly transition the part from its current mode.

The VCO will automatically calibrate at every frequency change or power up. The PLL T0 time is to allow for bias settling of the VCO. The PLL TS time is for the settling time of the PLL, which has a default setting of 100 μ s. The total time for PLL T0, PLL CAL, and PLL TS under all conditions is 200 μ s. Under certain applications, the PLL T0 time and the PLL CAL may be skipped for faster turn-around time. Contact applications support if faster turnaround time is desired.

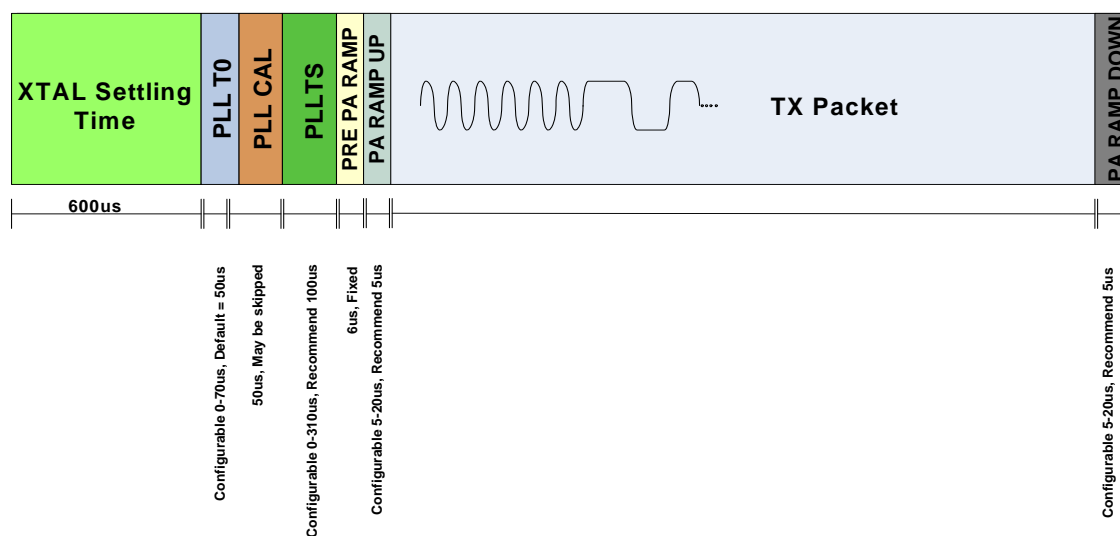

Figure 32.2. TX Timing

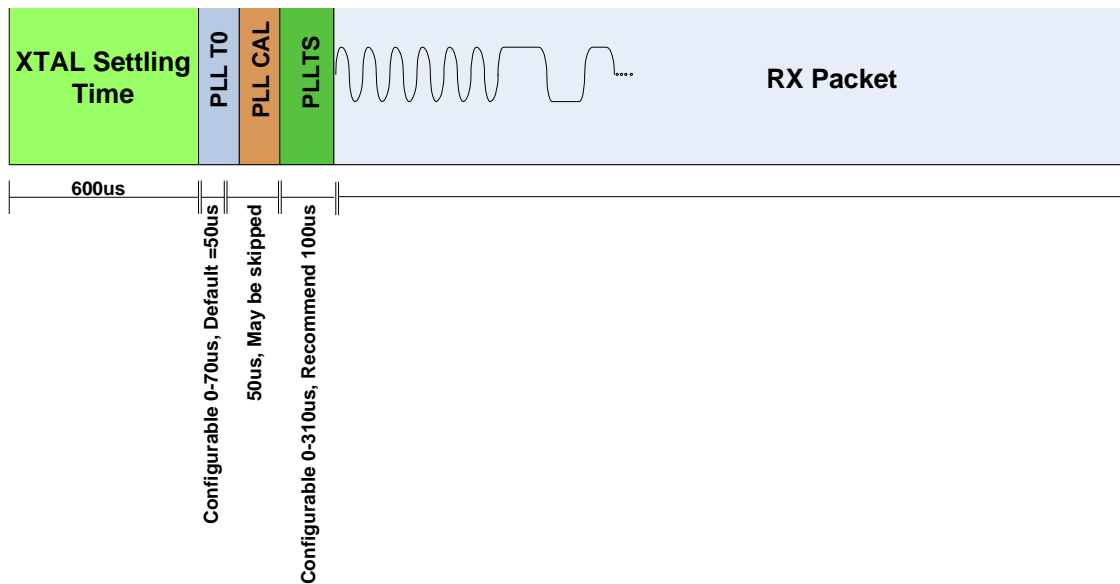

Figure 32.3. RX Timing

32.3.1. Frequency Control

For calculating the necessary frequency register settings it is recommended that customers use Silicon Labs' Wireless Design Suite (WDS) or the EZRadioPRO Register Calculator worksheet (in Microsoft Excel) available on the product website. These methods offer a simple method to quickly determine the correct settings based on the application requirements. The following information can be used to calculate these values manually.

32.3.2. Frequency Programming

In order to receive or transmit an RF signal, the desired channel frequency, $f_{carrier}$, must be programmed into the transceiver. Note that this frequency is the center frequency of the desired channel and not an LO frequency. The carrier frequency is generated by a Fractional-N Synthesizer, using 10 MHz both as the reference frequency and the clock of the (3rd order) $\Delta\Sigma$ modulator. This modulator uses modulo 64000 accumulators. This design was made to obtain the desired frequency resolution of the synthesizer. The overall division ratio of the feedback loop consist of an integer part (N) and a fractional part (F). In a generic sense, the output frequency of the synthesizer is as follows:

$$f_{OUT} = 10MHz \times (N + F)$$

The fractional part (F) is determined by three different values, Carrier Frequency (fc[15:0]), Frequency Offset (fo[8:0]), and Frequency Deviation (fd[7:0]). Due to the fine resolution and high loop bandwidth of the synthesizer, FSK modulation is applied inside the loop and is done by varying F according to the incoming data; this is discussed further in "Frequency Deviation" on page 452. Also, a fixed offset can be added to fine-tune the carrier frequency and counteract crystal tolerance errors. For simplicity assume that only the fc[15:0] register will determine the fractional component. The equation for selection of the carrier frequency is shown below:

$$f_{carrier} = 10MHz \times (hbssel + 1) \times (N + F)$$

$$f_{TX} = 10MHz * (hbssel + 1) * (fb[4:0] + 24 + \frac{fc[15:0]}{64000})$$

Add	R/W	Function/Description	D7	D6	D5	D4	D3	D2	D1	D0	POR Def.
73	R/W	Frequency Offset 1	fo[7]	fo[6]	fo[5]	fo[4]	fo[3]	fo[2]	fo[1]	fo[0]	00h
74	R/W	Frequency Offset 2							fo[9]	fo[8]	00h
75	R/W	Frequency Band Select		sbsel	hbssel	fb[4]	fb[3]	fb[2]	fb[1]	fb[0]	35h
76	R/W	Nominal Carrier Frequency 1	fc[15]	fc[14]	fc[13]	fc[12]	fc[11]	fc[10]	fc[9]	fc[8]	BBh
77	R/W	Nominal Carrier Frequency 0	fc[7]	fc[6]	fc[5]	fc[4]	fc[3]	fc[2]	fc[1]	fc[0]	80h

The integer part (N) is determined by fb[4:0]. Additionally, the output frequency can be halved by connecting a ÷2 divider to the output. This divider is not inside the loop and is controlled by the hbssel bit in "Register 75h. Frequency Band Select". This effectively partitions the entire 240–960 MHz frequency range into two separate bands: High Band (HB) for hbssel = 1, and Low Band (LB) for hbssel = 0. The valid range of fb[4:0] is from 0 to 23. If a higher value is written into the register, it will default to a value of 23. The integer part has a fixed offset of 24 added to it as shown in the formula above. Table 32.3 demonstrates the selection of fb[4:0] for the corresponding frequency band.

After selection of the fb (N) the fractional component may be solved with the following equation:

$$fc[15:0] = \left(\frac{f_{TX}}{10MHz * (hbssel + 1)} - fb[4:0] - 24 \right) * 64000$$

fb and fc are the actual numbers stored in the corresponding registers.

Table 32.3. Frequency Band Selection

fb[4:0] Value	N	Frequency Band	
		hbssel=0	hbssel=1
0	24	240–249.9 MHz	480–499.9 MHz
1	25	250–259.9 MHz	500–519.9 MHz
2	26	260–269.9 MHz	520–539.9 MHz
3	27	270–279.9 MHz	540–559.9 MHz
4	28	280–289.9 MHz	560–579.9 MHz
5	29	290–299.9 MHz	580–599.9 MHz
6	30	300–309.9 MHz	600–619.9 MHz
7	31	310–319.9 MHz	620–639.9 MHz
8	32	320–329.9 MHz	640–659.9 MHz

Table 32.3. Frequency Band Selection (Continued)

9	33	330–339.9 MHz	660–679.9 MHz
10	34	340–349.9 MHz	680–699.9 MHz
11	35	350–359.9 MHz	700–719.9 MHz
12	36	360–369.9 MHz	720–739.9 MHz
13	37	370–379.9 MHz	740–759.9 MHz
14	38	380–389.9 MHz	760–779.9 MHz
15	39	390–399.9 MHz	780–799.9 MHz
16	40	400–409.9 MHz	800–819.9 MHz
17	41	410–419.9 MHz	820–839.9 MHz
18	42	420–429.9 MHz	840–859.9 MHz
19	43	430–439.9 MHz	860–879.9 MHz
20	44	440–449.9 MHz	880–899.9 MHz
21	45	450–459.9 MHz	900–919.9 MHz
22	46	460–469.9 MHz	920–939.9 MHz
23	47	470–479.9 MHz	940–960 MHz

The chip will automatically shift the frequency of the Synthesizer down by 937.5 kHz (30 MHz ÷ 32) to achieve the correct Intermediate Frequency (IF) when RX mode is entered. Low-side injection is used in the RX Mixing architecture; therefore, no frequency reprogramming is required when using the same TX frequency and switching between RX/TX modes.

32.3.3. Easy Frequency Programming for FHSS

While Registers 73h–77h may be used to program the carrier frequency of the transceiver, it is often easier to think in terms of “channels” or “channel numbers” rather than an absolute frequency value in Hz. Also, there may be some timing-critical applications (such as for Frequency Hopping Systems) in which it is desirable to change frequency by programming a single register. Once the channel step size is set, the frequency may be changed by a single register corresponding to the channel number. A nominal frequency is first set using Registers 73h–77h, as described above. Registers 79h and 7Ah are then used to set a channel step size and channel number, relative to the nominal setting. The Frequency Hopping Step Size (fhs[7:0]) is set in increments of 10 kHz with a maximum channel step size of 2.56 MHz. The Frequency Hopping Channel Select Register then selects channels based on multiples of the step size.

$$F_{carrier} = F_{nom} + fhs[7:0] \times (fhch[7:0] \times 10kHz)$$

For example: if the nominal frequency is set to 900 MHz using Registers 73h–77h and the channel step size is set to 1 MHz using "Register 7Ah. Frequency Hopping Step Size". For example, if the "Register 79h. Frequency Hopping Channel Select" is set to 5d, the resulting carrier frequency would be 905 MHz. Once the nominal frequency and channel step size are programmed in the registers, it is only necessary to program the fhch[7:0] register in order to change the frequency.

Add	R/W	Function/Description	D7	D6	D5	D4	D3	D2	D1	D0	POR Def.
79	R/W	Frequency Hopping Channel Select	fhch[7]	fhch[6]	fhch[5]	fhch[4]	fhch[3]	fhch[2]	fhch[1]	fhch[0]	00h
7A	R/W	Frequency Hopping Step Size	fhs[7]	fhs[6]	fhs[5]	fhs[4]	fhs[3]	fhs[2]	fhs[1]	fhs[0]	00h

32.3.4. Automatic State Transition for Frequency Change

If registers 79h or 7Ah are changed in either TX or RX mode, the state machine will automatically transition the chip back to TUNE, change the frequency, and automatically go back to either TX or RX. This feature is useful to reduce the number of SPI commands required in a Frequency Hopping System. This in turn reduces microcontroller activity, reducing current consumption. The exception to this is during TX FIFO mode. If a frequency change is initiated during a TX packet, then the part will complete the current TX packet and will only change the frequency for subsequent packets.

32.3.5. Frequency Deviation

The peak frequency deviation is configurable from ± 0.625 to ± 320 kHz. The Frequency Deviation (Δf) is controlled by the Frequency Deviation Register (fd), address 71 and 72h, and is independent of the carrier frequency setting. When enabled, regardless of the setting of the hbsel bit (high band or low band), the resolution of the frequency deviation will remain in increments of 625 Hz. When using frequency modulation the carrier frequency will deviate from the nominal center channel carrier frequency by $\pm \Delta f$:

$$\Delta f = fd[8:0] \times 625Hz$$

$$fd[8:0] = \frac{\Delta f}{625Hz} \quad \Delta f = \text{peak deviation}$$

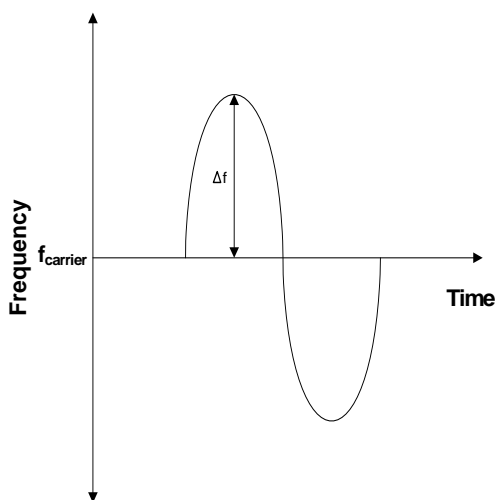

Figure 32.4. Frequency Deviation

The previous equation should be used to calculate the desired frequency deviation. If desired, frequency modulation may also be disabled in order to obtain an unmodulated carrier signal at the channel center frequency; see “Modulation Type” on page 455 for further details.

Add	R/W	Function/Description	D7	D6	D5	D4	D3	D2	D1	D0	POR Def.
71	R/W	Modulation Mode Control 2	trclk[1]	trclk[0]	dtmod[1]	dtmod[0]	enin	fd[8]	modtyp[1]	modtyp[0]	00h
72	R/W	Frequency Deviation	fd[7]	fd[6]	fd[5]	fd[4]	fd[3]	fd[2]	fd[1]	fd[0]	20h

32.3.6. Frequency Offset Adjustment

When the AFC is disabled the frequency offset can be adjusted manually by fo[9:0] in registers 73h and 74h. It is not possible to have both AFC and offset as internally they share the same register. The frequency offset adjustment and the AFC both are implemented by shifting the Synthesizer Local Oscillator frequency. This register is a signed register so in order to get a negative offset it is necessary to take the twos complement of the positive offset number. The offset can be calculated by the following:

$$DesiredOffset = 156.25Hz \times (hbssel + 1) \times fo[9:0]$$

$$fo[9:0] = \frac{DesiredOffset}{156.25Hz \times (hbssel + 1)}$$

The adjustment range in high band is ± 160 kHz and in low band it is ± 80 kHz. For example to compute an offset of +50 kHz in high band mode fo[9:0] should be set to 0A0h. For an offset of -50 kHz in high band mode the fo[9:0] register should be set to 360h.

Add	R/W	Function/Description	D7	D6	D5	D4	D3	D2	D1	D0	POR Def.
73	R/W	Frequency Offset	fo[7]	fo[6]	fo[5]	fo[4]	fo[3]	fo[2]	fo[1]	fo[0]	00h
74	R/W	Frequency Offset							fo[9]	fo[8]	00h

32.3.7. Automatic Frequency Control (AFC)

All AFC settings can be easily obtained from the settings calculator. This is the recommended method to program all AFC settings. This section is intended to describe the operation of the AFC in more detail to help understand the trade-offs of using AFC. The receiver supports automatic frequency control (AFC) to compensate for frequency differences between the transmitter and receiver reference frequencies. These differences can be caused by the absolute accuracy and temperature dependencies of the reference crystals. Due to frequency offset compensation in the modem, the receiver is tolerant to frequency offsets up to 0.25 times the IF bandwidth when the AFC is disabled. When the AFC is enabled, the received signal will be centered in the pass-band of the IF filter, providing optimal sensitivity and selectivity over a wider range of frequency offsets up to 0.35 times the IF bandwidth. The trade-off of receiver sensitivity (at 1% PER) versus carrier offset and the impact of AFC are illustrated in Figure 32.5.

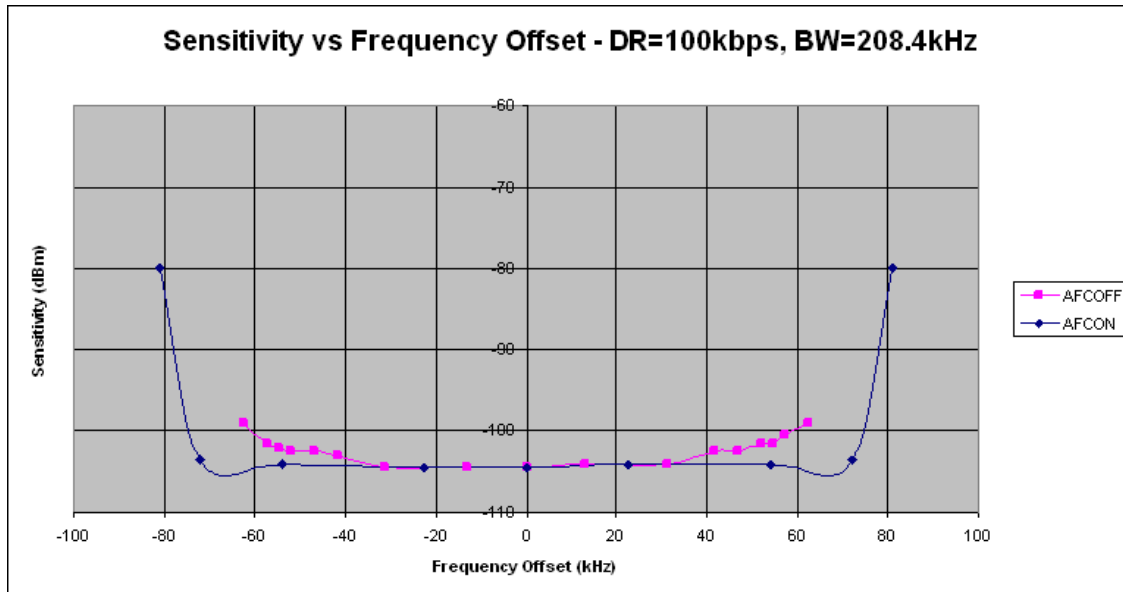

Figure 32.5. Sensitivity at 1% PER vs. Carrier Frequency Offset

When AFC is enabled, the preamble length needs to be long enough to settle the AFC. In general, one byte of preamble is sufficient to settle the AFC. Disabling the AFC allows the preamble to be shortened from 40 bits to 32 bits. Note that with the AFC disabled, the preamble length must still be long enough to settle the receiver and to detect the preamble (see “Preamble Length” on page 470). The AFC corrects the detected frequency offset by changing the frequency of the Fractional-N PLL. When the preamble is detected, the AFC will freeze for the remainder of the packet. In multi-packet mode the AFC is reset at the end of every packet and will re-acquire the frequency offset for the next packet. The AFC loop includes a bandwidth limiting mechanism improving the rejection of out of band signals. When the AFC loop is enabled, its pull-in-range is determined by the bandwidth limiter value (AFCLimiter) which is located in register 2Ah.

$$\text{AFC_pull_in_range} = \pm \text{AFCLimiter}[7:0] \times (\text{hbssel} + 1) \times 625 \text{ Hz}$$

The AFC Limiter register is an unsigned register and its value can be obtained from the EZRadioPRO Register Calculator spreadsheet.

The amount of error correction feedback to the Fractional-N PLL before the preamble is detected is controlled from `afcgearh[2:0]`. The default value 000 relates to a feedback of 100% from the measured frequency error and is advised for most applications. Every bit added will half the feedback but will require a longer preamble to settle.

The AFC operates as follows. The frequency error of the incoming signal is measured over a period of two bit times, after which it corrects the local oscillator via the Fractional-N PLL. After this correction, some time is allowed to settle the Fractional-N PLL to the new frequency before the next frequency error is measured. The duration of the AFC cycle before the preamble is detected can be programmed with `shwait[2:0]`. It is advised to use the default value 001, which sets the AFC cycle to 4 bit times (2 for measurement and 2 for settling). If `shwait[2:0]` is programmed to 3'b000, there is no AFC correction output. It is advised to use the default value 001, which sets the AFC cycle to 4 bit times (2 for measurement and 2 for settling).

The AFC correction value may be read from register 2Bh. The value read can be converted to kHz with the following formula:

$$\text{AFC Correction} = 156.25\text{Hz} \times (\text{hbssel} + 1) \times \text{afc_corr}[7: 0]$$

	Frequency Correction	
	RX	TX
AFC disabled	Freq Offset Register	Freq Offset Register
AFC enabled	AFC	Freq Offset Register

32.3.8. TX Data Rate Generator

The data rate is configurable between 0.123–256 kbps. For data rates below 30 kbps the "txdtrtscale" bit in register 70h should be set to 1. When higher data rates are used this bit should be set to 0.

The TX data rate is determined by the following formula in bps:

$$DR_TX \text{ (bps)} = \frac{txdr[15:0] \times 1 \text{ MHz}}{2^{16+5 \times txdtrtscale}}$$

$$txdr[15:0] = \frac{DR_TX(\text{bps}) \times 2^{16+5 \times txdtrtscale}}{1 \text{ MHz}}$$

For data rates higher than 100 kbps, Register 58h should be changed from its default of 80h to C0h. Non-optimal modulation and increased eye closure will result if this setting is not made for data rates higher than 100 kbps. The txdr register is only applicable to TX mode and does not need to be programmed for RX mode. The RX bandwidth which is partly determined from the data rate is programmed separately.

Add	R/W	Function/Description	D7	D6	D5	D4	D3	D2	D1	D0	POR Def.
6E	R/W	TX Data Rate 1	txdr[15]	txdr[14]	txdr[13]	txdr[12]	txdr[11]	txdr[10]	txdr[9]	txdr[8]	0Ah
6F	R/W	TX Data Rate 0	txdr[7]	txdr[6]	txdr[5]	txdr[4]	txdr[3]	txdr[2]	txdr[1]	txdr[0]	3Dh

32.4. Modulation Options

32.4.1. Modulation Type

The EZRadioPRO transceivers support three different modulation options: Gaussian Frequency Shift Keying (GFSK), Frequency Shift Keying (FSK), and On-Off Keying (OOK). GFSK is the recommended modulation type as it provides the best performance and cleanest modulation spectrum. Figure 32.6 demonstrates the difference between FSK and GFSK for a Data Rate of 64 kbps. The time domain plots demonstrate the effects of the Gaussian filtering. The frequency domain plots demonstrate the spectral benefit of GFSK over FSK. The type of modulation is selected with the modtyp[1:0] bits in "Register 71h. Modulation Mode Control 2". Note that it is also possible to obtain an unmodulated carrier signal by setting modtyp[1:0] = 00.

modtyp[1:0]	Modulation Source
00	Unmodulated Carrier
01	OOK
10	FSK
11	GFSK (enable TX Data CLK when direct mode is used)

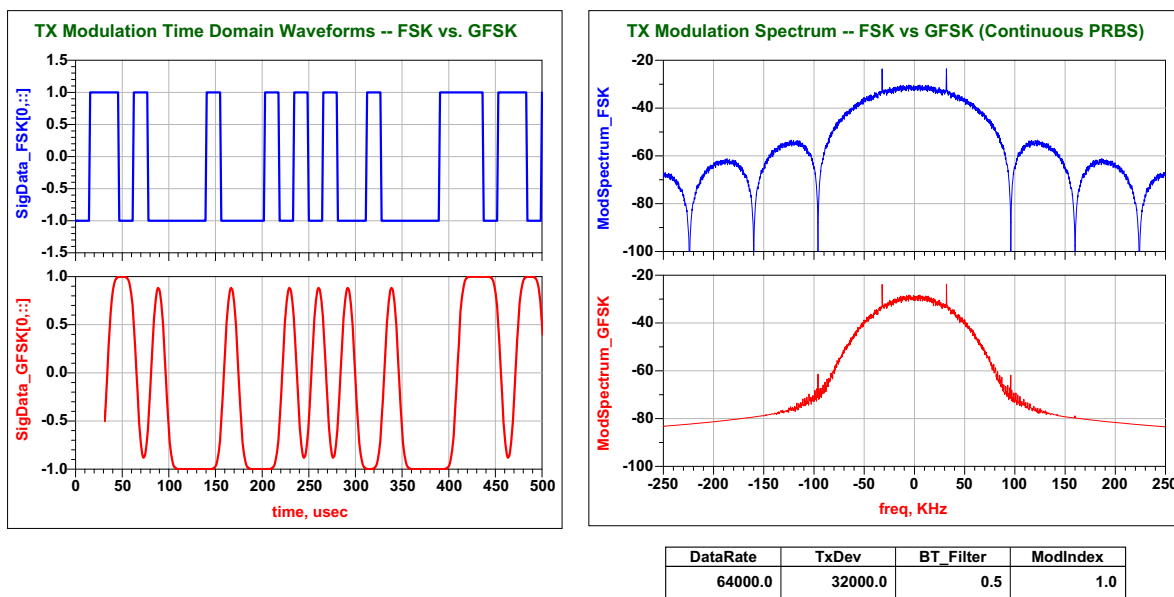

Figure 32.6. FSK vs. GFSK Spectrums

32.4.2. Modulation Data Source

The transceiver may be configured to obtain its modulation data from one of three different sources: FIFO mode, Direct Mode, and from a PN9 mode. In Direct Mode, the TX modulation data may be obtained from several different input pins. These options are set through the dtmod[1:0] field in "Register 71h. Modulation Mode Control 2".

Add	R/W	Function/Description	D7	D6	D5	D4	D3	D2	D1	D0	POR Def.
71	R/W	Modulation Mode Control 2	trclk[1]	trclk[0]	dtmod[1]	dtmod[0]	eninv	fd[8]	modtyp[1]	modtyp[0]	00h

dtmod[1:0]	Data Source
00	Direct Mode using TX/RX Data via GPIO pin (GPIO configuration required)
01	Direct Mode using TX/RX Data via SDI pin (only when nSEL is high)
10	FIFO Mode
11	PN9 (internally generated)

32.4.2.1. FIFO Mode

In FIFO mode, the transmit and receive data is stored in integrated FIFO register memory. The FIFOs are accessed via "Register 7Fh. FIFO Access," and are most efficiently accessed with burst read/write operation.

In TX mode, the data bytes stored in FIFO memory are "packaged" together with other fields and bytes of information to construct the final transmit packet structure. These other potential fields include the Preamble, Sync word, Header, CRC checksum, etc. The configuration of the packet structure in TX mode is

determined by the Automatic Packet Handler (if enabled), in conjunction with a variety of Packet Handler Registers (see Table 32.4 on page 469). If the Automatic Packet Handler is disabled, the entire desired packet structure should be loaded into FIFO memory; no other fields (such as Preamble or Sync word are automatically added to the bytes stored in FIFO memory). For further information on the configuration of the FIFOs for a specific application or packet size, see "Data Handling and Packet Handler" on page 465.

In RX mode, only the bytes of the received packet structure that are considered to be "data bytes" are stored in FIFO memory. Which bytes of the received packet are considered "data bytes" is determined by the Automatic Packet Handler (if enabled), in conjunction with the Packet Handler Registers (see Table 32.4 on page 469). If the Automatic Packet Handler is disabled, all bytes following the Sync word are considered data bytes and are stored in FIFO memory. Thus, even if Automatic Packet Handling operation is not desired, the preamble detection threshold and Sync word still need to be programmed so that the RX Modem knows when to start filling data into the FIFO. When the FIFO is being used in RX mode, all of the received data may still be observed directly (in real-time) by properly programming a GPIO pin as the RXDATA output pin; this can be quite useful during application development.

When in FIFO mode, the chip will automatically exit the TX or RX State when either the ipksent or ipkvalid interrupt occurs. The chip will return to the IDLE mode state programmed in "Register 07h. Operating Mode and Function Control 1". For example, the chip may be placed into TX mode by setting the txon bit, but with the pllon bit additionally set. The chip will transmit all of the contents of the FIFO and the ipksent interrupt will occur. When this interrupt event occurs, the chip will clear the txon bit and return to TUNE mode, as indicated by the set state of the pllon bit. If no other bits are additionally set in register 07h (besides txon initially), then the chip will return to the STANDBY state.

In RX mode, the rxon bit will be cleared if ipkvalid occurs and the rxmpk bit (RX Multi-Packet bit, SPI Register 08h bit [4]) is not set. When the rxmpk bit is set, the part will not exit the RX state after successfully receiving a packet, but will remain in RX mode. The microcontroller will need to decide on the appropriate subsequent action, depending upon information such as an interrupt generated by CRC, packet valid, or preamble detect.

32.4.2.2. Direct Mode

For legacy systems that perform packet handling within an MCU or other baseband chip, it may not be desirable to use the FIFO. For this scenario, a Direct Mode is provided which bypasses the FIFOs entirely.

In TX direct mode, the TX modulation data is applied to an input pin of the chip and processed in "real time" (i.e., not stored in a register for transmission at a later time). A variety of pins may be configured for use as the TX Data input function.

Furthermore, an additional pin may be required for a TX Clock output function if GFSK modulation is desired (only the TX Data input pin is required for FSK). Two options for the source of the TX Data are available in the dtmod[1:0] field, and various configurations for the source of the TX Data Clock may be selected through the trclk[1:0] field.

trclk[1:0]	TX/RX Data Clock Configuration
00	No TX Clock (only for FSK)
01	TX/RX Data Clock is available via GPIO (GPIO needs programming accordingly as well)
10	TX/RX Data Clock is available via SDO pin (only when nSEL is high)
11	TX/RX Data Clock is available via the nIRQ pin

The eninv bit in SPI Register 71h will invert the TX Data; this is most likely useful for diagnostic and testing purposes.

In RX direct mode, the RX Data and RX Clock can be programmed for direct (real-time) output to GPIO pins. The microcontroller may then process the RX data without using the FIFO or packet handler functions

of the RFIC. In RX direct mode, the chip must still acquire bit timing during the Preamble, and thus the preamble detection threshold (SPI Register 35h) must still be programmed. Once the preamble is detected, certain bit timing functions within the RX Modem change their operation for optimized performance over the remainder of the packet. It is not required that a Sync word be present in the packet in RX Direct mode; however, if the Sync word is absent then the skipsyn bit in SPI Register 33h must be set, or else the bit timing and tracking function within the RX Modem will not be configured for optimum performance.

32.4.2.3. Direct Synchronous Mode

In TX direct mode, the chip may be configured for synchronous or asynchronous modes of modulation. In direct synchronous mode, the RFIC is configured to provide a TX Clock signal as an output to the external device that is providing the TX Data stream. This TX Clock signal is a square wave with a frequency equal to the programmed data rate. The external modulation source (e.g., MCU) must accept this TX Clock signal as an input and respond by providing one bit of TX Data back to the RFIC, synchronous with one edge of the TX Clock signal. In this fashion, the rate of the TX Data input stream from the external source is controlled by the programmed data rate of the RFIC; no TX Data bits are made available at the input of the RFIC until requested by another cycle of the TX Clock signal. The TX Data bits supplied by the external source are transmitted directly in real-time (i.e., not stored internally for later transmission).

All modulation types (FSK/GFSK/OOK) are valid in TX direct synchronous mode. As will be discussed in the next section, there are limits on modulation types in TX direct asynchronous mode.

32.4.2.4. Direct Asynchronous Mode

In TX direct asynchronous mode, the RFIC no longer controls the data rate of the TX Data input stream. Instead, the data rate is controlled only by the external TX Data source; the RFIC simply accepts the data applied to its TX Data input pin, at whatever rate it is supplied. This means that there is no longer a need for a TX Clock output signal from the RFIC, as there is no synchronous "handshaking" between the RFIC and the external data source. The TX Data bits supplied by the external source are transmitted directly in real-time (i.e., not stored internally for later transmission).

It is not necessary to program the data rate parameter when operating in TX direct asynchronous mode. The chip still internally samples the incoming TX Data stream to determine when edge transitions occur; however, rather than sampling the data at a pre-programmed data rate, the chip now internally samples the incoming TX Data stream at its maximum possible oversampling rate. This allows the chip to accurately determine the timing of the bit edge transitions without prior knowledge of the data rate. (Of course, it is still necessary to program the desired peak frequency deviation.)

Only FSK and OOK modulation types are valid in TX Direct Asynchronous Mode; GFSK modulation is not available in asynchronous mode. This is because the RFIC does not have knowledge of the supplied data rate, and thus cannot determine the appropriate Gaussian lowpass filter function to apply to the incoming data.

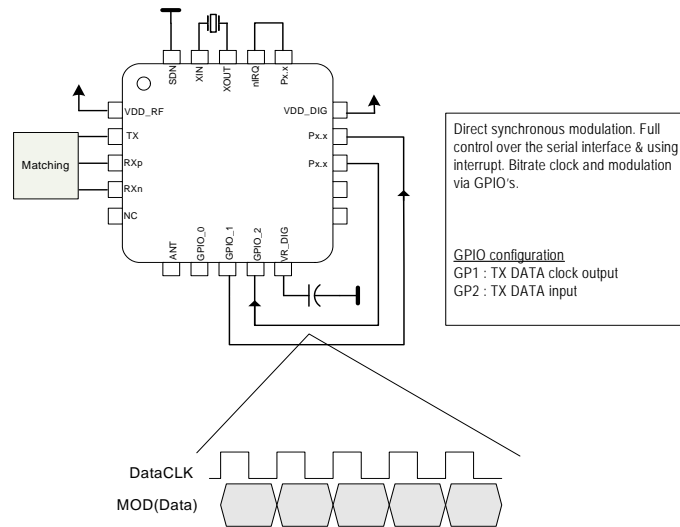

Figure 32.7. Direct Synchronous Mode Example

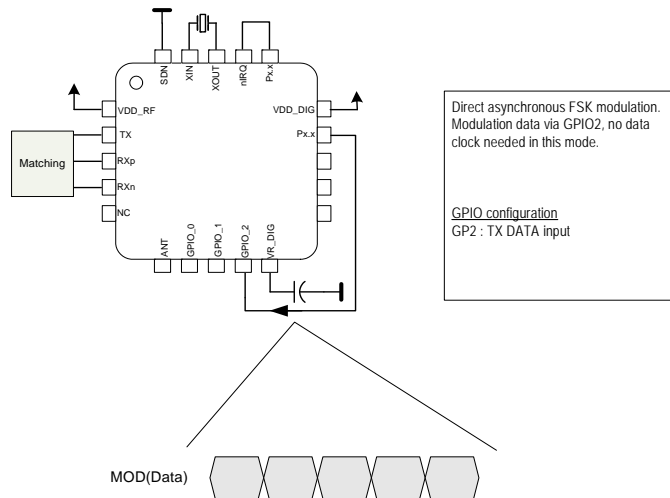

Figure 32.8. Direct Asynchronous Mode Example

32.4.2.5. Direct Mode using SPI or nIRQ Pins

It is possible to use the EZRadioPRO serial interface signals and nIRQ as the modulation clock and data. The MISO signal can be configured to be the data clock by programming `trclk = 10`. If the NSS signal is LOW then the function of the MISO signal will be SPI data output. If the NSS signal is high and `trclk[1:0]` is 10 then during RX and TX modes the data clock will be available on the MISO signal. If `trclk[1:0]` is set to 11 and no interrupts are enabled in registers 05 or 06h, then the nIRQ pin can also be used as the TX/RX data clock.

Note: The MISO and NSS signals are internal connections. The nIRQ signal is accessed through an external package pin.

The MOSI signal can be configured to be the data source in both RX and TX modes if `dtmod[1:0] = 01`. In a similar fashion, if NSS is LOW the MOSI signal will function as SPI data-in. If NSS is HIGH then in TX

Si102x/3x

mode it will be the data to be modulated and transmitted. In RX mode it will be the received demodulated data. Figure 32.9 demonstrates using MOSI and MISO as the TX/RX data and clock:

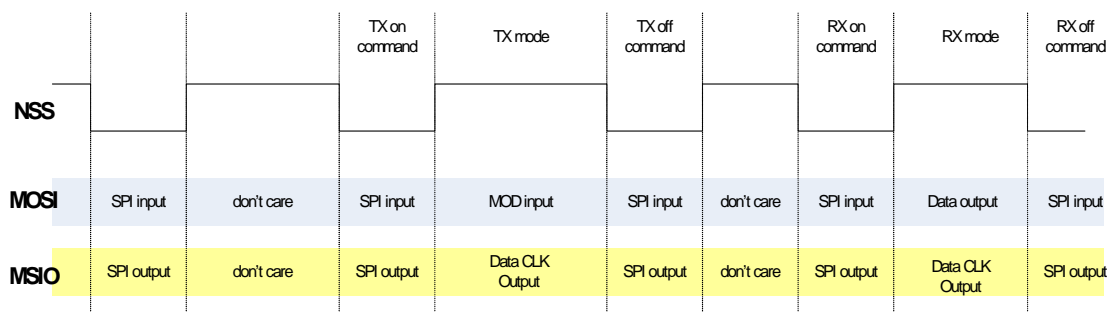

Figure 32.9. Microcontroller Connections

If the MISO pin is not used for data clock then it may be programmed to be the interrupt function (nIRQ) by programming Register 0Eh bit 3.

32.4.3. PN9 Mode

In this mode the TX data is generated internally using a pseudorandom (PN9 sequence) bit generator. The primary purpose of this mode is for use as a test mode to observe the modulated spectrum without having to provide data.

32.5. Internal Functional Blocks

This section provides an overview some of the key blocks of the internal radio architecture.

32.5.1. RX LNA

Depending on the part, the input frequency range for the LNA is between 240–960 MHz. The LNA provides gain with a noise figure low enough to suppress the noise of the following stages. The LNA has one step of gain control which is controlled by the analog gain control (AGC) algorithm. The AGC algorithm adjusts the gain of the LNA and PGA so the receiver can handle signal levels from sensitivity to +5 dBm with optimal performance.

In the Si1024/25/26/27/34/35/36/37, the TX and RX may be tied directly. See the TX/RX direct-tie reference design available on www.silabs.com. When the direct tie is used the Ina_sw bit in Register 6Dh, TX power must be set.

32.5.2. RX I-Q Mixer

The output of the LNA is fed internally to the input of the receive mixer. The receive mixer is implemented as an I-Q mixer that provides both I and Q channel outputs to the programmable gain amplifier. The mixer consists of two double-balanced mixers whose RF inputs are driven in parallel, local oscillator (LO) inputs are driven in quadrature, and separate I and Q Intermediate Frequency (IF) outputs drive the programmable gain amplifier. The receive LO signal is supplied by an integrated VCO and PLL synthesizer operating between 240–960 MHz. The necessary quadrature LO signals are derived from the divider at the VCO output.

32.5.3. Programmable Gain Amplifier

The programmable gain amplifier (PGA) provides the necessary gain to boost the signal level into the dynamic range of the ADC. The PGA must also have enough gain switching to allow for large input signals to ensure a linear RSSI range up to –20 dBm. The PGA has steps of 3 dB which are controlled by the AGC algorithm in the digital modem.

32.5.4. ADC

The amplified IQ IF signals are digitized using an Analog-to-Digital Converter (ADC), which allows for low current consumption and high dynamic range. The bandpass response of the ADC provides exceptional rejection of out of band blockers.

32.5.5. Digital Modem

Using high-performance ADCs allows channel filtering, image rejection, and demodulation to be performed in the digital domain, resulting in reduced area while increasing flexibility. The digital modem performs the following functions:

- Channel selection filter
- TX modulation
- RX demodulation
- AGC
- Preamble detector
- Invalid preamble detector
- Radio signal strength indicator (RSSI)
- Automatic frequency compensation (AFC)
- Packet handling including EZMAC[®] features
- Cyclic redundancy check (CRC)

The digital channel filter and demodulator are optimized for ultra low power consumption and are highly configurable. Supported modulation types are GFSK, FSK, and OOK. The channel filter can be configured to support bandwidths ranging from 620 kHz down to 2.6 kHz. A large variety of data rates are supported ranging from 0.123 up to 256 kbps. The AGC algorithm is implemented digitally using an advanced control loop optimized for fast response time.

The configurable preamble detector is used to improve the reliability of the sync-word detection. The sync-word detector is only enabled when a valid preamble is detected, significantly reducing the probability of false detection.

The received signal strength indicator (RSSI) provides a measure of the signal strength received on the tuned channel. The resolution of the RSSI is 0.5 dB. This high resolution RSSI enables accurate channel power measurements for clear channel assessment (CCA), carrier sense (CS), and listen before talk (LBT) functionality.

Frequency mistuning caused by crystal inaccuracies can be compensated by enabling the digital automatic frequency control (AFC) in receive mode.

A comprehensive programmable packet handler including key features of Silicon Labs' EZMAC is integrated to create a variety of communication topologies ranging from peer-to-peer networks to mesh networks. The extensive programmability of the packet header allows for advanced packet filtering which in turn enables a mix of broadcast, group, and point-to-point communication.

A wireless communication channel can be corrupted by noise and interference, and it is therefore important to know if the received data is free of errors. A cyclic redundancy check (CRC) is used to detect the presence of erroneous bits in each packet. A CRC is computed and appended at the end of each transmitted packet and verified by the receiver to confirm that no errors have occurred. The packet handler and CRC can significantly reduce the load on the microcontroller reducing the overall current consumption.

The digital modem includes the TX modulator which converts the TX data bits into the corresponding stream of digital modulation values to be summed with the fractional input to the sigma-delta modulator. This modulation approach results in highly accurate resolution of the frequency deviation. A Gaussian filter is implemented to support GFSK, considerably reducing the energy in the adjacent channels. The default bandwidth-time product (BT) is 0.5 for all programmed data rates, but it may be adjusted to other values.

Si102x/3x

32.5.6. Synthesizer

An integrated Sigma Delta ($\Sigma\Delta$) Fractional-N PLL synthesizer capable of operating from 240–960 MHz is provided on-chip. Using a $\Sigma\Delta$ synthesizer has many advantages; it provides flexibility in choosing data rate, deviation, channel frequency, and channel spacing. The transmit modulation is applied directly to the loop in the digital domain through the fractional divider which results in very precise accuracy and control over the transmit deviation.

Depending on the part, the PLL and Δ - Σ modulator scheme is designed to support any desired frequency and channel spacing in the range from 240–960 MHz with a frequency resolution of 156.25 Hz (Low band) or 312.5 Hz (High band). The transmit data rate can be programmed between 0.123–256 kbps, and the frequency deviation can be programmed between ± 1 –320 kHz. These parameters may be adjusted via registers as shown in “Frequency Control” on page 449.

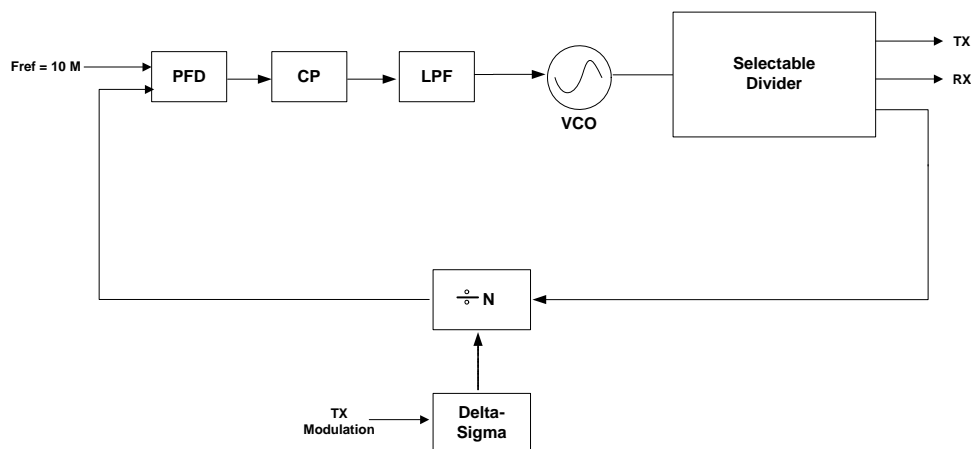

Figure 32.10. PLL Synthesizer Block Diagram

The reference frequency to the PLL is 10 MHz. The PLL utilizes a differential L-C VCO, with integrated on-chip inductors. The output of the VCO is followed by a configurable divider which will divide down the signal to the desired output frequency band. The modulus of the variable divide-by-N divider stage is controlled dynamically by the output from the Δ - Σ modulator. The tuning resolution is sufficient to tune to the commanded frequency with a maximum accuracy of 312.5 Hz anywhere in the range between 240–960 MHz.

32.5.6.1. VCO

The output of the VCO is automatically divided down to the correct output frequency depending on the `hbsel` and `fb[4:0]` fields in "Register 75h. Frequency Band Select". In receive mode, the LO frequency is automatically shifted downwards by the IF frequency of 937.5 kHz, allowing transmit and receive operation on the same frequency. The VCO integrates the resonator inductor and tuning varactor, so no external VCO components are required.

The VCO uses a capacitance bank to cover the wide frequency range specified. The capacitance bank will automatically be calibrated every time the synthesizer is enabled. In certain fast hopping applications this might not be desirable so the VCO calibration may be skipped by setting the appropriate register.

32.5.7. Power Amplifier

The Si1020/21/22/23/30/31/32/33 devices have an internal integrated power amplifier (PA) capable of transmitting at output levels between +1 and +20 dBm. The Si1024/25/26/27/34/35/36/37 devices have a PA which is capable of transmitting output levels between -8 to +13 dBm. The PA design is single-ended and is implemented as a two stage class CE amplifier with a high efficiency when transmitting at maximum power. The PA efficiency can only be optimized at one power level. Changing the output power by adjusting txpow[2:0] will scale both the output power and current but the efficiency will not remain constant. The PA output is ramped up and down to prevent unwanted spectral splatter.

With the Si1024/25/26/27/34/35/36/37 devices, the TX and RX may be tied directly. See the TX/RX direct-tie reference design available on the [Silicon Labs website](#) for more details. When the direct tie is used, the Ina_sw bit in Register 6Dh, TX Power must be set to 1.

32.5.7.1. Output Power Selection

The output power is configurable in 3 dB steps with the txpow[2:0] field in "Register 6Dh. TX Power". Extra output power can allow the use of a cheaper smaller antenna, greatly reducing the overall BOM cost. The higher power setting of the chip achieves maximum possible range, but of course comes at the cost of higher TX current consumption. However, depending on the duty cycle of the system, the effect on battery life may be insignificant.

Add	R/W	Function/ Description	D7	D6	D5	D4	D3	D2	D1	D0	POR Def.
6D	R/W	TX Power	reserved	reserved	reserved	reserved	Ina_sw	txpow[2]	txpow[1]	txpow[0]	18h

txpow[2:0]	Si10x0/1 Output Power
000	+1 dBm
001	+2 dBm
010	+5 dBm
011	+8 dBm
100	+11 dBm
101	+14 dBm
110	+17 dBm
111	+20 dBm

txpow[2:0]	Si10x2/3/4/5 Output Power
000	-8 dBm
001	-5 dBm
010	-2 dBm
011	+1 dBm
100	+4 dBm
101	+7 dBm
110	+10 dBm
111	+13 dBm

Si102x/3x

32.5.8. Crystal Oscillator

The transceiver includes an integrated 30 MHz crystal oscillator with a fast start-up time of less than 600 μ s when a suitable parallel resonant crystal is used. The design is differential with the required crystal load capacitance integrated on-chip to minimize the number of external components. By default, all that is required off-chip is the 30 MHz crystal.

The crystal load capacitance can be digitally programmed to accommodate crystals with various load capacitance requirements and to adjust the frequency of the crystal oscillator. The tuning of the crystal load capacitance is programmed through the xlc[6:0] field of "Register 09h. 30 MHz Crystal Oscillator Load Capacitance". The total internal capacitance is 12.5 pF and is adjustable in approximately 127 steps (97fF/step). The xtalshift bit provides a coarse shift in frequency but is not binary with xlc[6:0].

The crystal frequency adjustment can be used to compensate for crystal production tolerances. Utilizing the on-chip temperature sensor and suitable control software, the temperature dependency of the crystal can be canceled.

The typical value of the total on-chip capacitance C_{int} can be calculated as follows:

$$C_{int} = 1.8 \text{ pF} + 0.085 \text{ pF} \times \text{xlc}[6:0] + 3.7 \text{ pF} \times \text{xtalshift}$$

Note that the coarse shift bit xtalshift is not binary with xlc[6:0]. The total load capacitance C_{load} seen by the crystal can be calculated by adding the sum of all external parasitic PCB capacitances C_{ext} to C_{int}. If the maximum value of C_{int} (16.3 pF) is not sufficient, an external capacitor can be added for exact tuning. Additional information on calculating C_{ext} and crystal selection guidelines is provided in "AN417: Si4x3x Family Crystal Oscillator."

If AFC is disabled then the synthesizer frequency may be further adjusted by programming the Frequency Offset field fo[9:0] in "Register 73h. Frequency Offset 1" and "Register 74h. Frequency Offset 2", as discussed in "Frequency Control" on page 449.

The crystal oscillator frequency is divided down internally and may be output to the microcontroller through one of the GPIO pins for use as the System Clock. In this fashion, only one crystal oscillator is required for the entire system and the BOM cost is reduced. The available clock frequencies and GPIO configuration are discussed further in "Output Clock" on page 474.

The transceiver may also be driven with an external 30 MHz clock signal through the XOUT pin. When driving with an external reference or using a TCXO, the XTAL load capacitance register should be set to 0.

Add	R/W	Function/Description	D7	D6	D5	D4	D3	D2	D1	D0	POR Def.
09	R/W	Crystal Oscillator Load Capacitance	xtalshift	xlc[6]	xlc[5]	xlc[4]	xlc[3]	xlc[2]	xlc[1]	xlc[0]	7Fh

32.5.9. Regulators

There are a total of six regulators integrated onto the transceiver. With the exception of the digital regulator, all regulators are designed to operate with only internal decoupling. The digital regulator requires an external 1 μ F decoupling capacitor. All regulators are designed to operate with an input supply voltage from +1.8 to +3.6 V. The output stage of the PA is not connected internally to a regulator and is connected directly to the battery voltage.

A supply voltage should only be connected to the VDD pins. No voltage should be forced on the digital regulator output.

32.6. Data Handling and Packet Handler

The internal modem is designed to operate with a packet including a 010101... preamble structure. To configure the modem to operate with packet formats without a preamble or other legacy packet structures contact customer support.

32.6.1. RX and TX FIFOs

Two 64 byte FIFOs are integrated into the chip, one for RX and one for TX, as shown in Figure 32.11. "Register 7Fh. FIFO Access" is used to access both FIFOs. A burst write to address 7Fh will write data to the TX FIFO. A burst read from address 7Fh will read data from the RX FIFO.

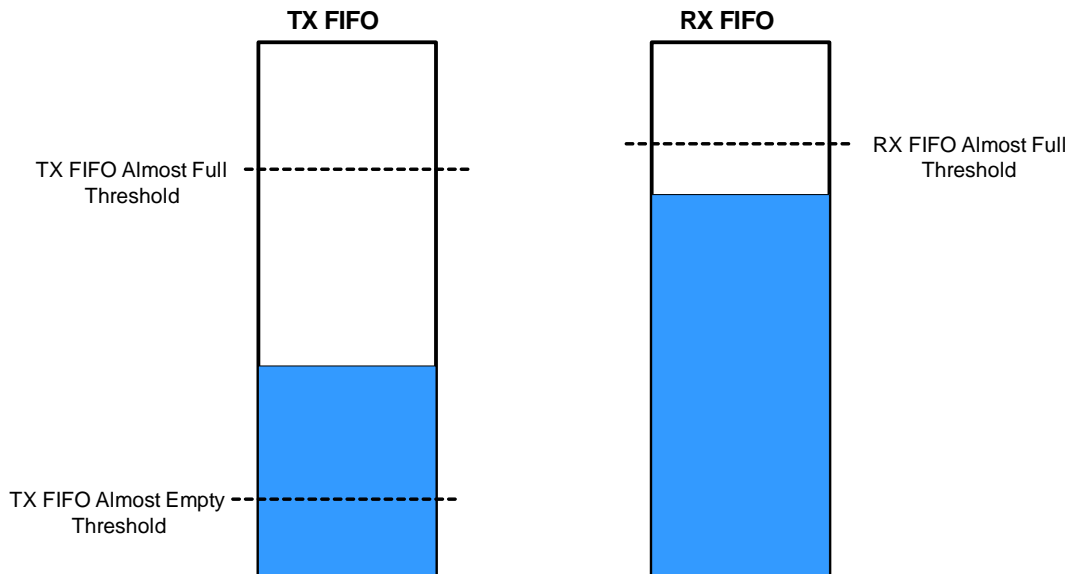

Figure 32.11. FIFO Thresholds

The TX FIFO has two programmable thresholds. An interrupt event occurs when the data in the TX FIFO reaches these thresholds. The first threshold is the FIFO almost full threshold, `txafthr[5:0]`. The value in this register corresponds to the desired threshold value in number of bytes. When the data being filled into the TX FIFO crosses this threshold limit, an interrupt to the microcontroller is generated so the chip can enter TX mode to transmit the contents of the TX FIFO. The second threshold for TX is the FIFO almost empty threshold, `txaethr[5:0]`. When the data being shifted out of the TX FIFO drops below the almost empty threshold an interrupt will be generated. If more data is not loaded into the FIFO then the chip automatically exits the TX State after the `ipksent` interrupt occurs. The chip will return to the mode selected by the remaining bits in SPI Register 07h. For example, the chip may be placed into TX mode by setting the `txon` bit, but with the `xton` bit additionally set. For this condition, the chip will transmit all of the contents of the FIFO and the `ipksent` interrupt will occur. When this interrupt event occurs, the chip will clear the `txon` bit and return to READY mode, as indicated by the set state of the `xton` bit. If the `pllon` bit D1 is set when entering TX mode (i.e., SPI Register 07h = 0Ah), the chip will exit from TX mode after sending the packet and return to TUNE mode.

However, the chip will not automatically return to STANDBY mode upon exit from the TX state, in the event the TX packet is initiated by setting SPI Register 07h = 08h (i.e., setting only `txon` bit D3). The chip will instead return to READY mode, with the crystal oscillator remaining enabled. This is intentional; the system may be configured such that the host MCU derives its clock from the `MCU_CLK` output of the RFIC (through GPIO2), and this clock signal must not be shut down without allowing the host MCU time to process any interrupt signals that may have occurred. The host MCU must subsequently perform a WRITE to SPI Register 07h = 00h to enter STANDBY mode and obtain minimum current consumption.

Si102x/3x

Add	R/W	Function/Description	D7	D6	D5	D4	D3	D2	D1	D0	POR Def.
08	R/W	Operating & Function Control 2	antdiv[2]	antdiv[1]	antdiv[0]	rxmpk	autotx	enldm	ffclrx	ffclrtx	00h
7C	R/W	TX FIFO Control 1	Reserved	Reserved	txafthr[5]	txafthr[4]	txafthr[3]	txafthr[2]	txafthr[1]	txafthr[0]	37h
7D	R/W	TX FIFO Control 2	Reserved	Reserved	txaethr[5]	txaethr[4]	txaethr[3]	txaethr[2]	txaethr[1]	txaethr[0]	04h

The RX FIFO has one programmable threshold called the FIFO Almost Full Threshold, rxafthr[5:0]. When the incoming RX data crosses the Almost Full Threshold an interrupt will be generated to the microcontroller via the nIRQ pin. The microcontroller will then need to read the data from the RX FIFO.

Add	R/W	Function/Description	D7	D6	D5	D4	D3	D2	D1	D0	POR Def.
7E	R/W	RX FIFO Control	Reserved	Reserved	rxafthr[5]	rxafthr[4]	rxafthr[3]	rxafthr[2]	rxafthr[1]	rxafthr[0]	37h

Both the TX and RX FIFOs may be cleared or reset with the ffclrtx and ffclrx bits. All interrupts may be enabled by setting the Interrupt Enabled bits in "Register 05h. Interrupt Enable 1" and "Register 06h. Interrupt Enable 2." If the interrupts are not enabled the function will not generate an interrupt on the nIRQ pin but the bits will still be read correctly in the Interrupt Status registers.

32.6.2. Packet Configuration

When using the FIFOs, automatic packet handling may be enabled for TX mode, RX mode, or both. "Register 30h. Data Access Control" through "Register 4Bh. Received Packet Length" control the configuration, status, and decoded RX packet data for Packet Handling. The usual fields for network communication (such as preamble, synchronization word, headers, packet length, and CRC) can be configured to be automatically added to the data payload. The fields needed for packet generation normally change infrequently and can therefore be stored in registers. Automatically adding these fields to the data payload greatly reduces the amount of communication between the microcontroller and the transceiver.

The general packet structure is shown in Figure 32.12. The length of each field is shown below the field. The preamble pattern is always a series of alternating ones and zeroes, starting with a zero. All the fields have programmable lengths to accommodate different applications. The most common CRC polynomials are available for selection.

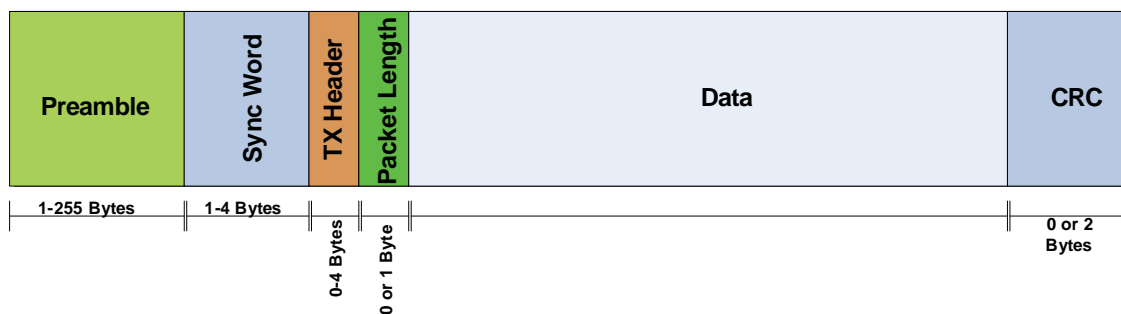

Figure 32.12. Packet Structure

An overview of the packet handler configuration registers is shown in Table 32.4.

32.6.3. Packet Handler TX Mode

If the TX packet length is set the packet handler will send the number of bytes in the packet length field before returning to IDLE mode and asserting the packet sent interrupt. To resume sending data from the FIFO the microcontroller needs to command the chip to re-enter TX mode. Figure 32.13 provides an example transaction where the packet length is set to three bytes.

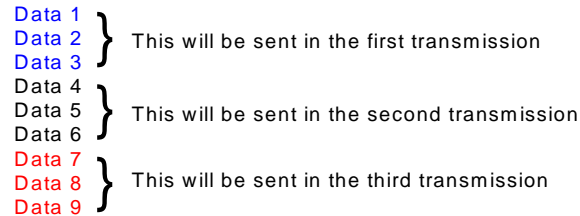

Figure 32.13. Multiple Packets in TX Packet Handler

32.6.4. Packet Handler RX Mode

32.6.4.1. Packet Handler Disabled

When the packet handler is disabled certain fields in the received packet are still required. Proper modem operation requires preamble and sync when the FIFO is being used, as shown in Figure 32.14. Bits after sync will be treated as raw data with no qualification. This mode allows for the creation of a custom packet handler when the automatic qualification parameters are not sufficient. Manchester encoding is supported but data whitening, CRC, and header checks are not.

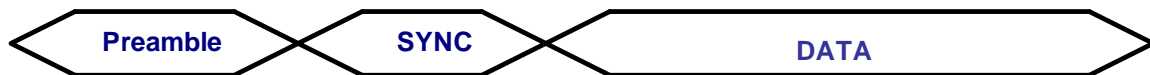

Figure 32.14. Required RX Packet Structure with Packet Handler Disabled

32.6.4.2. Packet Handler Enabled

When the packet handler is enabled, all the fields of the packet structure need to be configured. Register contents are used to construct the header field and length information encoded into the transmitted packet when transmitting. The receive FIFO can be configured to handle packets of fixed or variable length with or without a header. If multiple packets are desired to be stored in the FIFO, then there are options available for the different fields that will be stored into the FIFO. Figure 32.15 demonstrates the options and settings available when multiple packets are enabled. Figure 32.16 demonstrates the operation of fixed packet length and correct/incorrect packets.

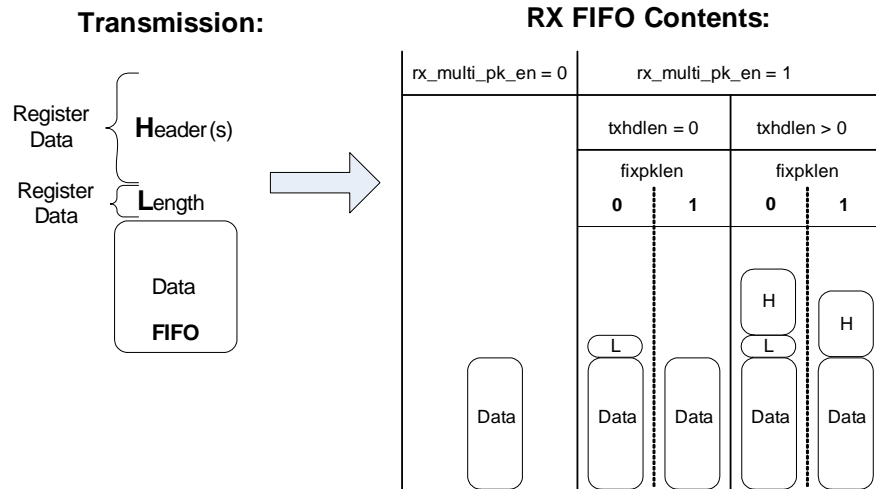

Figure 32.15. Multiple Packets in RX Packet Handler

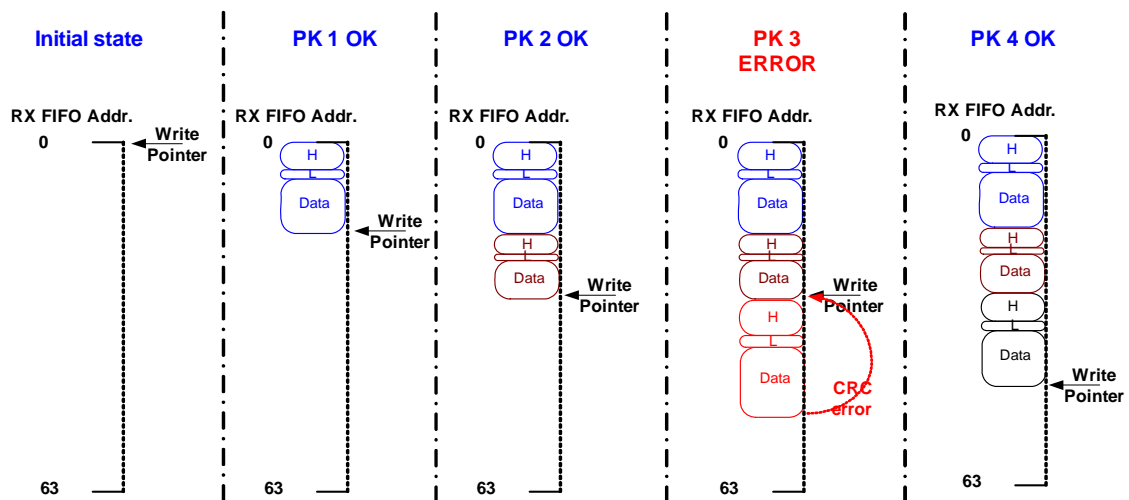

Figure 32.16. Multiple Packets in RX with CRC or Header Error

Table 32.4. Packet Handler Registers

Add	R/W	Function/Description	D7	D6	D5	D4	D3	D2	D1	D0	POR Def
30	R/W	Data Access Control	enpacrx	lsbfrst	crconly	skip2ph	enpactx	encrc	crc[1]	crc[0]	8Dh
31	R	EzMAC status	0	rxcrc1	pkscrch	pkrx	pkvalid	crcerror	pktx	pkstent	—
32	R/W	Header Control 1	bcen[3:0]				hdch[3:0]				0Ch
33	R/W	Header Control 2	skipsyn	hdlen[2]	hdlen[1]	hdlen[0]	fixpklen	syncnlen[1]	syncnlen[0]	prealen[8]	22h
34	R/W	Preamble Length	prealen[7]	prealen[6]	prealen[5]	prealen[4]	prealen[3]	prealen[2]	prealen[1]	prealen[0]	08h
35	R/W	Preamble Detection Control	preath[4]	preath[3]	preath[2]	preath[1]	preath[0]	rssloff[2]	rssloff[1]	rssloff[0]	2Ah
36	R/W	Sync Word 3	sync[31]	sync[30]	sync[29]	sync[28]	sync[27]	sync[26]	sync[25]	sync[24]	2Dh
37	R/W	Sync Word 2	sync[23]	sync[22]	sync[21]	sync[20]	sync[19]	sync[18]	sync[17]	sync[16]	D4h
38	R/W	Sync Word 1	sync[15]	sync[14]	sync[13]	sync[12]	sync[11]	sync[10]	sync[9]	sync[8]	00h
39	R/W	Sync Word 0	sync[7]	sync[6]	sync[5]	sync[4]	sync[3]	sync[2]	sync[1]	sync[0]	00h
3A	R/W	Transmit Header 3	txhd[31]	txhd[30]	txhd[29]	txhd[28]	txhd[27]	txhd[26]	txhd[25]	txhd[24]	00h
3B	R/W	Transmit Header 2	txhd[23]	txhd[22]	txhd[21]	txhd[20]	txhd[19]	txhd[18]	txhd[17]	txhd[16]	00h
3C	R/W	Transmit Header 1	txhd[15]	txhd[14]	txhd[13]	txhd[12]	txhd[11]	txhd[10]	txhd[9]	txhd[8]	00h
3D	R/W	Transmit Header 0	txhd[7]	txhd[6]	txhd[5]	txhd[4]	txhd[3]	txhd[2]	txhd[1]	txhd[0]	00h
3E	R/W	Transmit Packet Length	pklen[7]	pklen[6]	pklen[5]	pklen[4]	pklen[3]	pklen[2]	pklen[1]	pklen[0]	00h
3F	R/W	Check Header 3	chhd[31]	chhd[30]	chhd[29]	chhd[28]	chhd[27]	chhd[26]	chhd[25]	chhd[24]	00h
40	R/W	Check Header 2	chhd[23]	chhd[22]	chhd[21]	chhd[20]	chhd[19]	chhd[18]	chhd[17]	chhd[16]	00h
41	R/W	Check Header 1	chhd[15]	chhd[14]	chhd[13]	chhd[12]	chhd[11]	chhd[10]	chhd[9]	chhd[8]	00h
42	R/W	Check Header 0	chhd[7]	chhd[6]	chhd[5]	chhd[4]	chhd[3]	chhd[2]	chhd[1]	chhd[0]	00h
43	R/W	Header Enable 3	hden[31]	hden[30]	hden[29]	hden[28]	hden[27]	hden[26]	hden[25]	hden[24]	FFh
44	R/W	Header Enable 2	hden[23]	hden[22]	hden[21]	hden[20]	hden[19]	hden[18]	hden[17]	hden[16]	FFh
45	R/W	Header Enable 1	hden[15]	hden[14]	hden[13]	hden[12]	hden[11]	hden[10]	hden[9]	hden[8]	FFh
46	R/W	Header Enable 0	hden[7]	hden[6]	hden[5]	hden[4]	hden[3]	hden[2]	hden[1]	hden[0]	FFh
47	R	Received Header 3	rxhd[31]	rxhd[30]	rxhd[29]	rxhd[28]	rxhd[27]	rxhd[26]	rxhd[25]	rxhd[24]	—
48	R	Received Header 2	rxhd[23]	rxhd[22]	rxhd[21]	rxhd[20]	rxhd[19]	rxhd[18]	rxhd[17]	rxhd[16]	—
49	R	Received Header 1	rxhd[15]	rxhd[14]	rxhd[13]	rxhd[12]	rxhd[11]	rxhd[10]	rxhd[9]	rxhd[8]	—
4A	R	Received Header 0	rxhd[7]	rxhd[6]	rxhd[5]	rxhd[4]	rxhd[3]	rxhd[2]	rxhd[1]	rxhd[0]	—
4B	R	Received Packet Length	rxplen[7]	rxplen[6]	rxplen[5]	rxplen[4]	rxplen[3]	rxplen[2]	rxplen[1]	rxplen[0]	—

32.6.5. Data Whitening, Manchester Encoding, and CRC

Data whitening can be used to avoid extended sequences of 0s or 1s in the transmitted data stream to achieve a more uniform spectrum. When enabled, the payload data bits are XORed with a pseudorandom sequence output from the built-in PN9 generator. The generator is initialized at the beginning of the payload. The receiver recovers the original data by repeating this operation. Manchester encoding can be used to ensure a dc-free transmission and good synchronization properties. When Manchester encoding is used, the effective datarate is unchanged but the actual datarate (preamble length, etc.) is doubled due to the nature of the encoding. The effective datarate when using Manchester encoding is limited to 128 kbps. The implementation of Manchester encoding is shown in Figure 32.18. Data whitening and Manchester encoding can be selected with "Register 70h. Modulation Mode Control 1". The CRC is configured via "Register 30h. Data Access Control". Figure 32.17 demonstrates the portions of the packet which have Manchester encoding, data whitening, and CRC applied. CRC can be applied to only the data portion of the packet or to the data, packet length and header fields. Figure 32.18 provides an example of how the Manchester encoding is done and also the use of the Manchester invert (enmaniv) function.

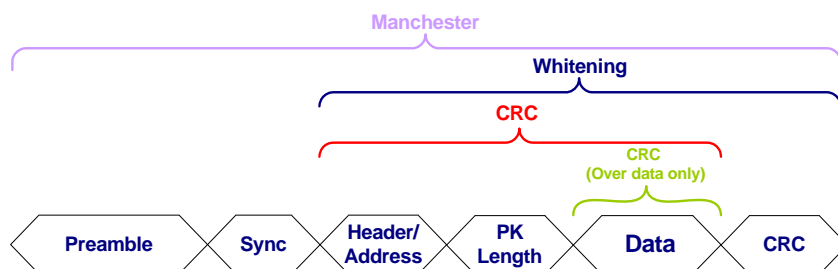

Figure 32.17. Operation of Data Whitening, Manchester Encoding, and CRC

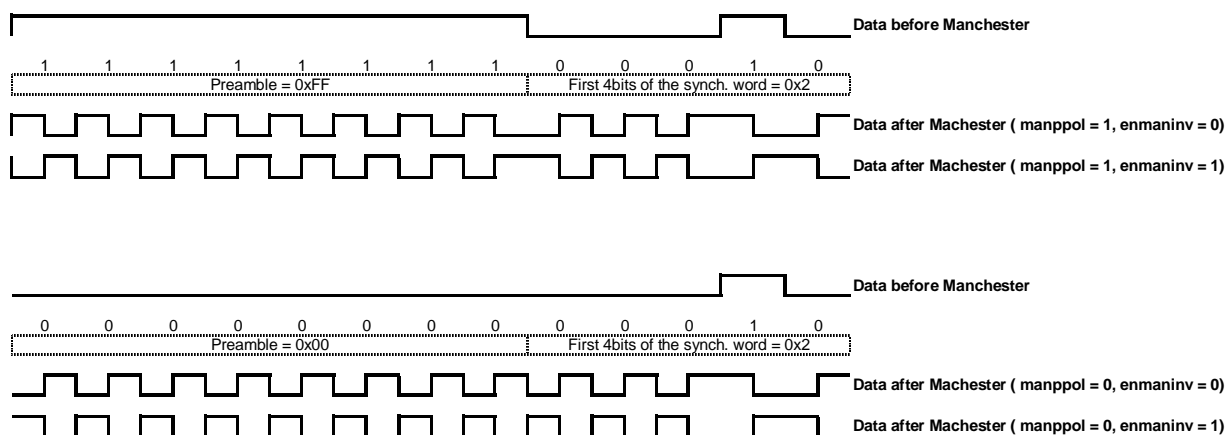

Figure 32.18. Manchester Coding Example

32.6.6. Preamble Detector

The EZRadioPRO transceiver has integrated automatic preamble detection. The preamble length is configurable from 1–255 bytes using the `prealen[7:0]` field in "Register 33h. Header Control 2" and "Register 34h. Preamble Length", as described in "32.6.2. Packet Configuration". The preamble detection threshold, `preath[4:0]` as set in "Register 35h. Preamble Detection Control 1", is in units of 4 bits. The preamble detector searches for a preamble pattern with a length of `preath[4:0]`.

If a false preamble detect occurs, the receiver will continue searching for the preamble when no sync word is detected. Once preamble is detected (false or real) then the part will then start searching for sync. If no sync occurs then a timeout will occur and the device will initiate search for preamble again. The timeout period is defined as the sync word length plus four bits and will start after a non-preamble pattern is recognized after a valid preamble detection. The preamble detector output may be programmed onto one of the GPIO or read in the interrupt status registers.

32.6.7. Preamble Length

The preamble detection threshold determines the number of valid preamble bits the radio must receive to qualify a valid preamble. The preamble threshold should be adjusted depending on the nature of the application. The required preamble length threshold will depend on when receive mode is entered in relation to the start of the transmitted packet and the length of the transmit preamble. With a shorter than recommended preamble detection threshold the probability of false detection is directly related to how long the receiver operates on noise before the transmit preamble is received. False detection on noise may cause the actual packet to be missed. The preamble detection threshold is programmed in register 35h. For most applications with a preamble length longer than 32 bits the default value of 20 is recommended for the pre-

amble detection threshold. A shorter Preamble Detection Threshold may be chosen if occasional false detections may be tolerated. When antenna diversity is enabled a 20-bit preamble detection threshold is recommended. When the receiver is synchronously enabled just before the start of the packet, a shorter preamble detection threshold may be used. Table 32.5 demonstrates the recommended preamble detection threshold and preamble length for various modes.

It is possible to use the transceiver in a raw mode without the requirement for a 010101... preamble. Contact customer support for further details.

Table 32.5. Minimum Receiver Settling Time

Mode	Approximate Receiver Settling Time	Recommended Preamble Length with 8-Bit Detection Threshold	Recommended Preamble Length with 20-Bit Detection Threshold
(G)FSK AFC Disabled	1 byte	20 bits	32 bits
(G)FSK AFC Enabled	2 byte	28 bits	40 bits
(G)FSK AFC Disabled +Antenna Diversity Enabled	1 byte	—	64 bits
(G)FSK AFC Enabled +Antenna Diversity Enabled	2 byte	—	8 byte
OOK	2 byte	3 byte	4 byte
OOK + Antenna Diversity Enabled	8 byte	—	8 byte

Note: The recommended preamble length and preamble detection threshold listed above are to achieve 0% PER. They may be shortened when occasional packet errors are tolerable.

32.6.8. Invalid Preamble Detector

When scanning channels in a frequency hopping system it is desirable to determine if a channel is valid in the minimum amount of time. The preamble detector can output an invalid preamble detect signal, which can be used to identify the channel as invalid. After a configurable time set in Register 60h[7:4], an invalid preamble detect signal is asserted indicating an invalid channel. The period for evaluating the signal for invalid preamble is defined as $(inv_pre_th[3:0] \times 4) \times \text{Bit Rate Period}$. The preamble detect and invalid preamble detect signals are available in "Register 03h. Interrupt/Status 1" and "Register 04h. Interrupt/Status 2."

32.6.9. Synchronization Word Configuration

The synchronization word length for both TX and RX can be configured in Reg 33h, `synclen[1:0]`. The expected or transmitted sync word can be configured from 1 to 4 bytes as defined below:

- `synclen[1:0] = 00`—Expected/Transmitted Synchronization Word (sync word) 3.
- `synclen[1:0] = 01`—Expected/Transmitted Synchronization Word 3 first, followed by sync word 2.
- `synclen[1:0] = 10`—Expected/Transmitted Synchronization Word 3 first, followed by sync word 2, followed by sync word 1.
- `synclen[1:0] = 11`—Send/Expect Synchronization Word 3 first, followed by sync word 2, followed by sync word 1, followed by sync word 0.

The sync is transmitted or expected in the following sequence: sync 3→sync 2→sync 1→sync 0. The sync word values can be programmed in Registers 36h–39h. After preamble detection the part will search for sync for a fixed period of time. If a sync is not recognized in this period then a timeout will occur and the search for preamble will be re-initiated. The timeout period after preamble detections is defined as the value programmed into the sync word length plus four additional bits.

32.6.10. Receive Header Check

The header check is designed to support 1–4 bytes and broadcast headers. The header length needs to be set in register 33h, `hdlen[2:0]`. The headers to be checked need to be set in register 32h, `hdch[3:0]`. For instance, there can be four bytes of header in the packet structure but only one byte of the header is set to be checked (i.e., header 3). For the headers that are set to be checked, the expected value of the header should be programmed in `chhd[31:0]` in Registers 3F–42. The individual bits within the selected bytes to be checked can be enabled or disabled with the header enables, `hden[31:0]` in Registers 43–46. For example, if you want to check all bits in header 3 then `hden[31:24]` should be set to FF but if only the last 4 bits are desired to be checked then it should be set to 00001111 (0F). Broadcast headers can also be programmed by setting `bcen[3:0]` in Register 32h. For broadcast header check the value may be either “FFh” or the value stored in the Check Header register. A logic equivalent of the header check for Header 3 is shown in Figure 32.19. A similar logic check will be done for Header 2, Header 1, and Header 0 if enabled.

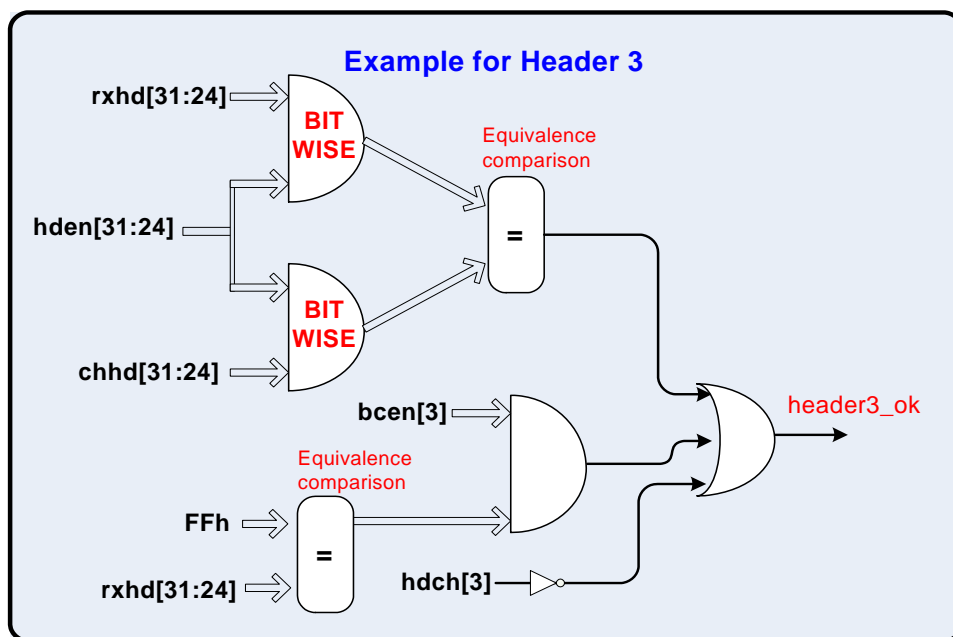

Figure 32.19. Header

32.6.11. TX Retransmission and Auto TX

The transceiver is capable of automatically retransmitting the last packet loaded in the TX FIFO. Automatic retransmission is set by entering the TX state with the `txon` bit without reloading the TX FIFO. This feature is useful for beacon transmission or when retransmission is required due to the absence of a valid acknowledgement. Only packets that fit completely in the TX FIFO can be automatically retransmitted.

An automatic transmission function is available, allowing the radio to automatically start or stop a transmission depending on the amount of data in the TX FIFO.

When `autotx` is set in “Register 08. Operating & Function Control 2”, the transceiver will automatically enter the TX state when the TX FIFO almost full threshold is exceeded. Packets will be transmitted according to the configured packet length. To stop transmitting, clear the packet sent or TX FIFO almost empty interrupts must be cleared by reading register.

32.7. RX Modem Configuration

A Microsoft Excel parameter calculator or Wireless Development Suite (WDS) calculator is provided to determine the proper settings for the modem. The calculator can be found on www.silabs.com or on the CD provided with the demo kits. An application note is available to describe how to use the calculator and to provide advanced descriptions of the modem settings and calculations.

32.7.1. Modem Settings for FSK and GFSK

The modem performs channel selection and demodulation in the digital domain. The channel filter bandwidth is configurable from 2.6 to 620 kHz. The receiver data-rate, modulation index, and bandwidth are set via registers 1C–25h. The modulation index is equal to 2 times the peak deviation divided by the data rate (R_b).

When Manchester coding is disabled, the required channel filter bandwidth is calculated as $BW = 2F_d + R_b$ where F_d is the frequency deviation and R_b is the data rate.

32.8. Auxiliary Functions

The EZRadioPRO has some auxiliary functions that duplicate the directly accessible MCU peripherals: ADC, temperature sensor, and 32 kHz oscillator. These auxiliary functions are retained primarily for compatibility with the Si4430/1/2. The directly accessed MCU peripherals typically provide lower system current consumption and better analog performance. However some of these EZRadioPRO auxiliary functions offer features not directly duplicated in the MCU directly accessed peripherals, such as the Low Duty Cycle Mode operation.

32.8.1. Smart Reset

The EZRadioPRO transceiver contains an enhanced integrated SMART RESET or POR circuit. The POR circuit contains both a classic level threshold reset as well as a slope detector POR. This reset circuit was designed to produce a reliable reset signal under any circumstances. Reset will be initiated if any of the following conditions occur:

- Initial power on, V_{DD} starts from gnd: reset is active till V_{DD} reaches V_{RR} (see table);
- When V_{DD} decreases below V_{LD} for any reason: reset is active till V_{DD} reaches V_{RR} ;
- A software reset via “Register 08h. Operating Mode and Function Control 2”: reset is active for time T_{SWRST}
- On the rising edge of a V_{DD} glitch when the supply voltage exceeds the following time functioned limit:

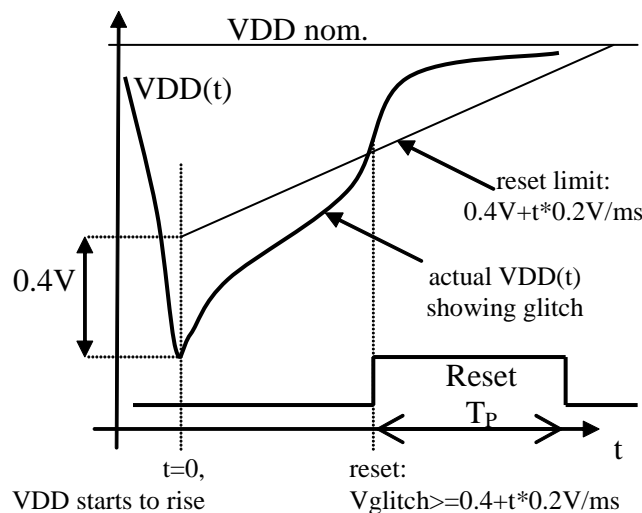

Figure 32.20. POR Glitch Parameters

Table 32.6. POR Parameters

Parameter	Symbol	Comment	Min	Typ	Max	Unit
Release Reset Voltage	VRR		0.85	1.3	1.75	V
Power-On V_{DD} Slope	SVDD	tested V_{DD} slope region	0.03	—	300	V/ms
Low V_{DD} Limit	VLD	$VLD < VRR$ is guaranteed	0.7	1	1.3	V
Software Reset Pulse	TSWRST		50	—	470	us
Threshold Voltage	VTSD		—	0.4	—	V
Reference Slope	k		—	0.2	—	V/ms
V_{DD} Glitch Reset Pulse	TP	Also occurs after SDN, and initial power on	5	16	25	ms

The reset will initialize all registers to their default values. The reset signal is also available for output and use by the microcontroller by using the default setting for GPIO_0. The inverted reset signal is available by default on GPIO_1.

32.8.2. Output Clock

The 30 MHz crystal oscillator frequency is divided down internally and may be output on GPIO2. This feature is useful to lower BOM cost by using only one crystal in the system. The output clock on GPIO2 may be routed to the XTAL2 input to provide a synchronized clock source between the MCU and the EZRadio-PRO peripheral. The output clock frequency is selectable from one of 8 options, as shown below. Except for the 32.768 kHz option, all other frequencies are derived by dividing the crystal oscillator frequency. The 32.768 kHz clock signal is derived from an internal RC oscillator or an external 32 kHz crystal. The default setting for GPIO2 is to output the clock signal with a frequency of 1 MHz.

Add	R/W	Function/Description	D7	D6	D5	D4	D3	D2	D1	D0	POR Def.
0A	R/W	Output Clock			clkt[1]	clkt[0]	enlfc	mclk[2]	mclk[1]	mclk[0]	06h

mclk[2:0]	Modulation Source
000	30 MHz
001	15 MHz
010	10 MHz
011	4 MHz
100	3 MHz
101	2 MHz
110	1 MHz
111	32.768 kHz

Since the crystal oscillator is disabled in SLEEP mode in order to save current, the low-power 32.768 kHz clock can be automatically switched to become the output clock. This feature is called enable low frequency clock and is enabled by the enlfc bit in "Register 0Ah. Microcontroller Output Clock." When enlfc = 1 and the chip is in SLEEP mode then the 32.768 kHz clock will be provided regardless of the setting of mclk[2:0]. For example, if mclk[2:0] = 000, 30 MHz will be provided through the GPIO output pin in all IDLE,

TX, or RX states. When the chip enters SLEEP mode, the output clock will automatically switch to 32.768 kHz from the RC oscillator or 32.768 XTAL.

Another available feature for the output clock is the clock tail, `clkt[1:0]` in "Register 0Ah. Microcontroller Output Clock." If the low frequency clock feature is not enabled (`enlfc = 0`), then the output is disabled in SLEEP mode. Setting the `clkt[1:0]` field will provide additional cycles of the output clock before it shuts off.

<code>clkt[1:0]</code>	Modulation Source
00	0 cycles
01	128 cycles
10	256 cycles
11	512 cycles

If an interrupt is triggered, the output clock will remain enabled regardless of the selected mode. As soon as the interrupt is read the state machine will then move to the selected mode. The minimum current consumption will not be achieved until the interrupt is read. For instance, if the EZRadioPRO peripheral is commanded to SLEEP mode but an interrupt has occurred the 30 MHz XTAL will not be disabled until the interrupt has been cleared.

32.8.3. General Purpose ADC

The EZRadioPRO peripheral includes an 8-bit SAR ADC independent of ADC0. It may be used for general purpose analog sampling, as well as for digitizing the EZRadioPRO temperature sensor reading. In most cases, the ADC0 subsystem directly accessible from the MCU will be preferred over the ADC embedded inside the EZRadioPRO peripheral. Registers 0Fh "ADC Configuration", 10h "Sensor Offset" and 4Fh "Amplifier Offset" can be used to configure the ADC operation. Details of these registers are in "AN440: EZRadioPRO Detailed Register Descriptions."

Every time an ADC conversion is desired, bit 7 "adcstart/adcdone" in Register 0Fh "ADC Configuration" must be set to 1. The conversion time for the ADC is 350 μ s. After the ADC conversion is done and the adcdone signal is showing 1, then the ADC value may be read out of "Register 11h: ADC Value." When the ADC is doing its conversion, the adcstart/adcdone bit will read 0. When the ADC has finished its conversion, the bit will be set to 1. A new ADC conversion can be initiated by writing a 1 to the adcstart/adcdone bit.

The architecture of the ADC is shown in Figure 32.21. The signal and reference inputs of the ADC are selected by `adc sel[2:0]` and `ad cref[1:0]` in register 0Fh "ADC Configuration", respectively. The default setting is to read out the temperature sensor using the bandgap voltage (VBG) as reference. With the VBG reference the input range of the ADC is from 0–1.02 V with an LSB resolution of 4 mV (1.02/255). Changing the ADC reference will change the LSB resolution accordingly.

A differential multiplexer and amplifier are provided for interfacing external bridge sensors. The gain of the amplifier is selectable by `adc gain[1:0]` in Register 0Fh. The majority of sensor bridges have supply voltage (V_{DD}) dependent gain and offset. The reference voltage of the ADC can be changed to either $V_{DD}/2$ or $V_{DD}/3$. A programmable V_{DD} dependent offset voltage can be added using `soffs[3:0]` in register 10h.

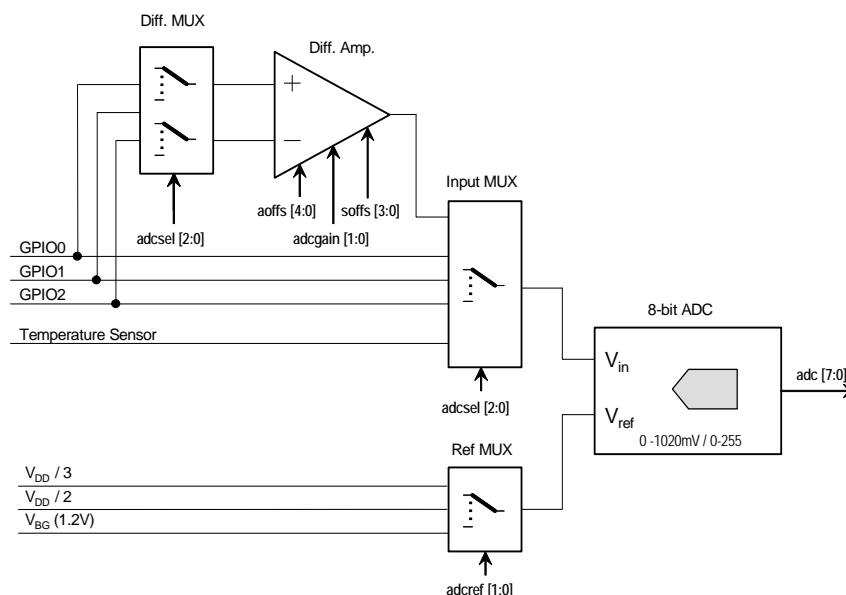

Figure 32.21. General Purpose ADC Architecture

Add	R/W	Function/Description	D7	D6	D5	D4	D3	D2	D1	D0	POR Def.
0F	R/W	ADC Configuration	adcstart/adcdone	adcsel[2]	adcsel[1]	adcsel[0]	adcref[1]	adcref[0]	adcgain[1]	adcgain[0]	00h
10	R/W	Sensor Offset					soffs[3]	soffs[2]	soffs[1]	soffs[0]	00h
11	R	ADC Value	adc[7]	adc[6]	adc[5]	adc[4]	adc[3]	adc[2]	adc[1]	adc[0]	—

32.8.4. Temperature Sensor

The EZRadioPRO peripheral includes an integrated on-chip analog temperature sensor independent of the temperature sensor associated with ADC0. The temperature sensor will be automatically enabled when the temperature sensor is selected as the input of the EZRadioPRO ADC or when the analog temp voltage is selected on the analog test bus. The temperature sensor value may be digitized using the EZRadioPRO general-purpose ADC and read out through "Register 10h. ADC Sensor Amplifier Offset." The range of the temperature sensor is configurable. Table 32.7 lists the settings for the different temperature ranges and performance.

To use the Temp Sensor:

1. Set the input for ADC to the temperature sensor, "Register 0Fh. ADC Configuration"—adcsel[2:0] = 000
2. Set the reference for ADC, "Register 0Fh. ADC Configuration"—adcref[1:0] = 00
3. Set the temperature range for ADC, "Register 12h. Temperature Sensor Calibration"—tsrange[1:0]
4. Set entsoffs = 1, "Register 12h. Temperature Sensor Calibration"
5. Trigger ADC reading, "Register 0Fh. ADC Configuration"—adcstart = 1
6. Read temperature value—Read contents of "Register 11h. ADC Value"

Add	R/W	Function/Description	D7	D6	D5	D4	D3	D2	D1	D0	POR Def.
12	R/W	Temperature Sensor Control	tsrange[1]	tsrange[0]	entsoffs	entstrim	tstrim[3]	tstrim[2]	vbgttrim[1]	vbgttrim[0]	20h
13	R/W	Temperature Value Offset	tvofts[7]	tvofts[6]	tvofts[5]	tvofts[4]	tvofts[3]	tvofts[2]	tvofts[1]	tvofts[0]	00h

Table 32.7. Temperature Sensor Range

entoff	tsrange[1]	tsrange[0]	Temp. range	Unit	Slope	ADC8 LSB
1	0	0	-64 ... 64	°C	8 mV/°C	0.5 °C
1	0	1	-64 ... 192	°C	4 mV/°C	1 °C
1	1	0	0 ... 128	°C	8 mV/°C	0.5 °C
1	1	1	-40 ... 216	°F	4 mV/°F	1 °F
0*	1	0	0 ... 341	°K	3 mV/°K	1.333 °K

Note: Absolute temperature mode, no temperature shift. This mode is only for test purposes. POR value of EN_TOFF is 1.

The slope of the temperature sensor is very linear and monotonic. For absolute accuracy better than 10 °C calibration is necessary. The temperature sensor may be calibrated by setting entsoffs = 1 in “Register 12h. Temperature Sensor Control” and setting the offset with the tvofts[7:0] bits in “Register 13h. Temperature Value Offset.” This method adds a positive offset digitally to the ADC value that is read in “Register 11h. ADC Value.” The other method of calibration is to use the tstrim which compensates the analog circuit. This is done by setting entstrim = 1 and using the tstrim[2:0] bits to offset the temperature in “Register 12h. Temperature Sensor Control.” With this method of calibration, a negative offset may be achieved. With both methods of calibration better than ±3 °C absolute accuracy may be achieved.

The different ranges for the temperature sensor and ADC8 are demonstrated in Figure 32.22. The value of the ADC8 may be translated to a temperature reading by $ADC8Value \times ADC8\ LSB + \text{Lowest Temperature in Temp Range}$. For instance for a tsrange = 00, $Temp = ADC8Value \times 0.5 - 64$.

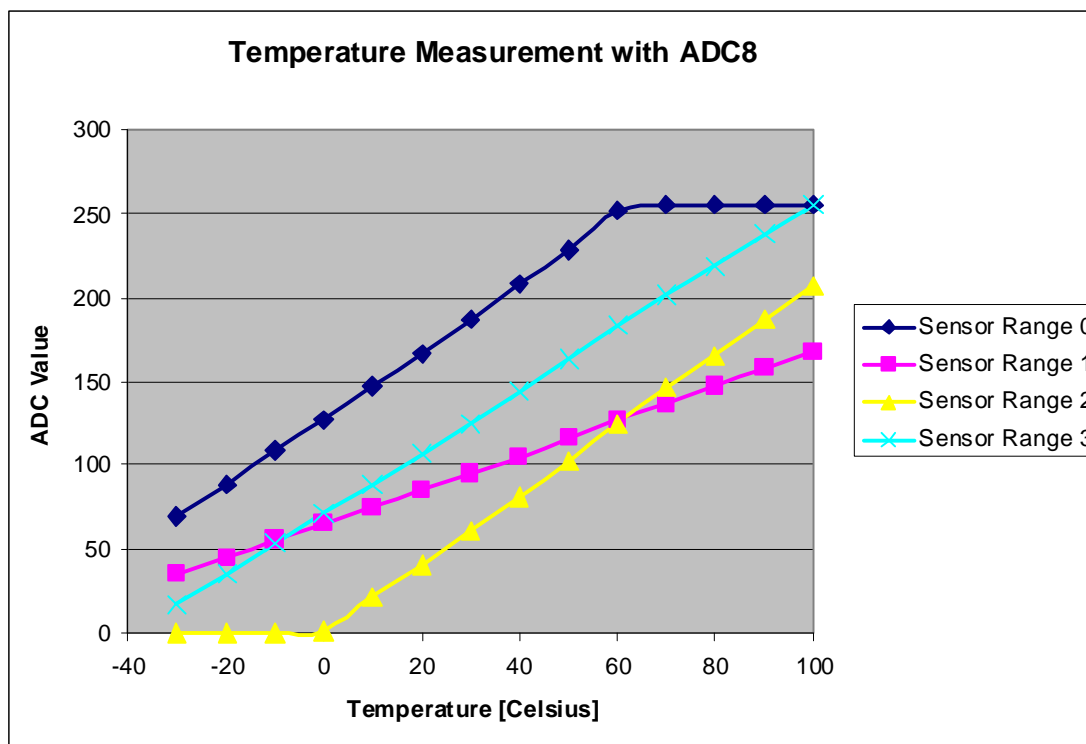

Figure 32.22. Temperature Ranges using ADC8

32.8.5. Low Battery Detector

A low battery detector (LBD) with digital read-out is integrated into the chip. A digital threshold may be programmed into the `lbd[4:0]` field in "Register 1Ah. Low Battery Detector Threshold". When the digitized battery voltage reaches this threshold an interrupt will be generated on the `nIRQ` pin to the microcontroller. The microcontroller can confirm source of the interrupt by reading "Register 03h. Interrupt/Status 1" and "Register 04h. Interrupt/Status 2."

If the LBD is enabled while the chip is in SLEEP mode, it will automatically enable the RC oscillator which will periodically turn on the LBD circuit to measure the battery voltage. The battery voltage may also be read out through "Register 1Bh. Battery Voltage Level" at any time when the LBD is enabled. The low battery detect function is enabled by setting `enlbd=1` in "Register 07h. Operating Mode and Function Control 1".

Add	R/W	Function/Description	D7	D6	D5	D4	D3	D2	D1	D0	POR Def.
1A	R/W	Low Battery Detector Threshold				<code>lbd[4]</code>	<code>lbd[3]</code>	<code>lbd[2]</code>	<code>lbd[1]</code>	<code>lbd[0]</code>	14h
1B	R	Battery Voltage Level	0	0	0	<code>vbat[4]</code>	<code>vbat[3]</code>	<code>vbat[2]</code>	<code>vbat[1]</code>	<code>vbat[0]</code>	—

The LBD output is digitized by a 5-bit ADC. When the LBD function is enabled (`enlbd = 1` in "Register 07h. Operating Mode and Function Control 1") the battery voltage may be read at anytime by reading "Register 1Bh. Battery Voltage Level." A battery voltage threshold may be programmed in "Register 1Ah. Low Battery Detector Threshold". When the battery voltage level drops below the battery voltage threshold an interrupt will be generated on `nIRQ` pin to the microcontroller if the LBD interrupt is enabled in "Register

06h. Interrupt Enable 2." The microcontroller will then need to verify the interrupt by reading the interrupt status register, addresses 03 and 04h. The LSB step size for the LBD ADC is 50 mV, with the ADC range demonstrated in the table below. If the LBD is enabled the LBD and ADC will automatically be enabled every 1 s for approximately 250 μ s to measure the voltage which minimizes the current consumption in Sensor mode. Before an interrupt is activated four consecutive readings are required.

$$\text{BatteryVoltage} = 1.7 + 50\text{mV} \times \text{ADCValue}$$

ADC Value	VDD Voltage [V]
0	< 1.7
1	1.7–1.75
2	1.75–1.8
...	...
29	3.1–3.15
30	3.15–3.2
31	> 3.2

32.8.6. Wake-Up Timer and 32 kHz Clock Source

The EZRadioPRO peripheral contains an integrated wake-up timer independent of the SmartClock which can be used to periodically wake the chip from SLEEP mode using the interrupt pin. The wake-up timer runs from the internal 32.768 kHz RC Oscillator. The wake-up timer can be configured to run when in SLEEP mode. If `enwt = 1` in "Register 07h. Operating Mode and Function Control 1" when entering SLEEP mode, the wake-up timer will count for a time specified defined in Registers 14–16h, "Wake Up Timer Period". At the expiration of this period an interrupt will be generated on the nIRQ pin if this interrupt is enabled. The software will then need to verify the interrupt by reading the Registers 03h–04h, "Interrupt Status 1 & 2". The wake-up timer value may be read at any time by the `wtv[15:0]` read only registers 17h–18h.

The formula for calculating the Wake-Up Period is the following:

$$WUT = \frac{32 \times M \times 2^R}{32.768} \text{ms}$$

WUT Register	Description
<code>wtr[4:0]</code>	R Value in Formula
<code>wtm[15:0]</code>	M Value in Formula

Use of the D variable in the formula is only necessary if finer resolution is required than can be achieved by using the R value.

Si102x/3x

Add	R/W	Function/Description	D7	D6	D5	D4	D3	D2	D1	D0	POR Def.
14	R/W	Wake-Up Timer Period 1				wtr[4]	wtr[3]	wtr[2]	wtr[1]	wtr[0]	03h
15	R/W	Wake-Up Timer Period 2	wtm[15]	wtm[14]	wtm[13]	wtm[12]	wtm[11]	wtm[10]	wtm[9]	wtm[8]	00h
16	R/W	Wake-Up Timer Period 3	wtm[7]	wtm[6]	wtm[5]	wtm[4]	wtm[3]	wtm[2]	wtm[1]	wtm[0]	00h
17	R	Wake-Up Timer Value 1	wtv[15]	wtv[14]	wtv[13]	wtv[12]	wtv[11]	wtv[10]	wtv[9]	wtv[8]	—
18	R	Wake-Up Timer Value 2	wtv[7]	wtv[6]	wtv[5]	wtv[4]	wtv[3]	wtv[2]	wtv[1]	wtv[0]	—

There are two different methods for utilizing the wake-up timer (WUT) depending on if the WUT interrupt is enabled in “Register 06h. Interrupt Enable 2.” If the WUT interrupt is enabled then nIRQ pin will go low when the timer expires. The chip will also change state so that the 30 MHz XTAL is enabled so that the microcontroller clock output is available for the microcontroller to use to process the interrupt. The other method of use is to not enable the WUT interrupt and use the WUT GPIO setting. In this mode of operation the chip will not change state until commanded by the microcontroller. The different modes of operating the WUT and the current consumption impacts are demonstrated in Figure 32.23.

A 32 kHz XTAL may also be used for better timing accuracy. By setting the x32 ksel bit in Register 07h "Operating & Function Control 1", GPIO0 is automatically reconfigured so that an external 32 kHz XTAL may be connected to this pin. In this mode, the GPIO0 is extremely sensitive to parasitic capacitance, so only the XTAL should be connected to this pin with the XTAL physically located as close to the pin as possible. Once the x32 ksel bit is set, all internal functions such as WUT, microcontroller clock, and LDC mode will use the 32 kHz XTAL and not the 32 kHz RC oscillator.

The 32 kHz XTAL accuracy is comprised of both the XTAL parameters and the internal circuit. The XTAL accuracy can be defined as the XTAL initial error + XTAL aging + XTAL temperature drift + detuning from the internal oscillator circuit. The error caused by the internal circuit is typically less than 10 ppm.

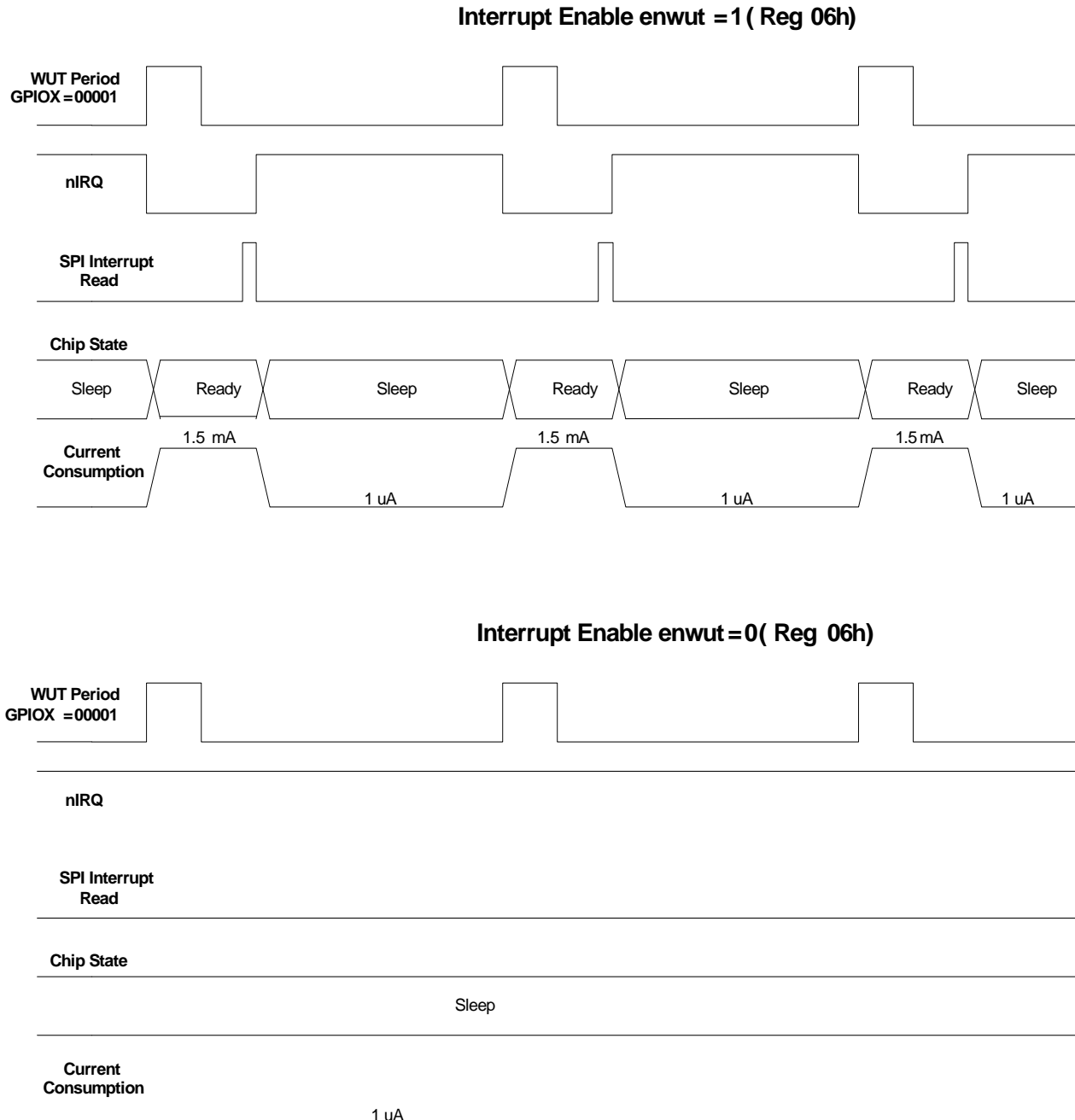

Figure 32.23. WUT Interrupt and WUT Operation

32.8.7. Low Duty Cycle Mode

The Low Duty Cycle Mode is available to automatically wake-up the receiver to check if a valid signal is available. The basic operation of the low duty cycle mode is demonstrated in the figure below. If a valid preamble or sync word is not detected the chip will return to sleep mode until the beginning of a new WUT period. If a valid preamble and sync are detected the receiver on period will be extended for the low duty cycle mode duration (TLDC) to receive all of the packet. The WUT period must be set in conjunction with the low duty cycle mode duration. The R value (“Register 14h. Wake-up Timer Period 1”) is shared

Si102x/3x

between the WUT and the TLDC. The $ldc[7:0]$ bits are located in “Register 19h. Low Duty Cycle Mode Duration.” The time of the TLDC is determined by the formula below:

$$TLDC = ldc [7 : 0] \times \frac{4 \times 2^R}{32.768} ms$$

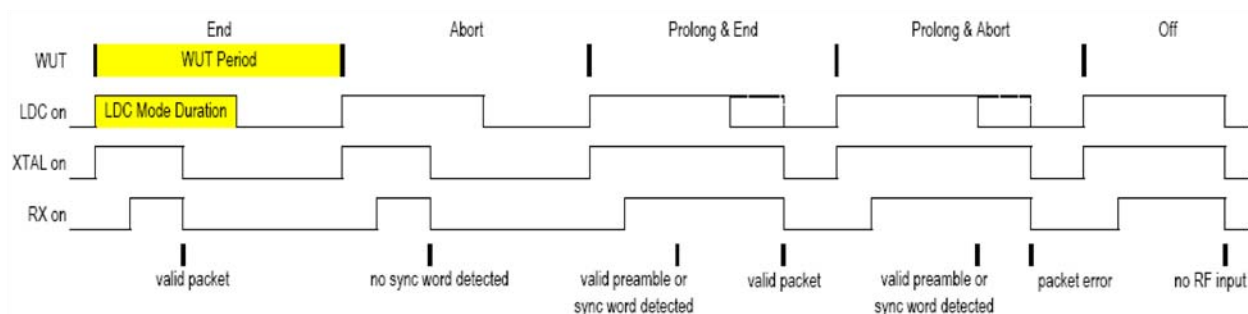

Figure 32.24. Low Duty Cycle Mode

32.8.8. GPIO Configuration

Three general purpose IOs (GPIOs) are available. Numerous functions such as specific interrupts, TRSW control, etc. can be routed to the GPIO pins as shown in the tables below. When in Shutdown mode all the GPIO pads are pulled low.

Note: The ADC should not be selected as an input to the GPIO in standby or sleep modes and will cause excess current consumption.

Add	R/W	Function/Description	D7	D6	D5	D4	D3	D2	D1	D0	POR Def.
0B	R/W	GPIO0 Configuration	gpio0drv[1]	gpio0drv[0]	pup0	gpio0[4]	gpio0[3]	gpio0[2]	gpio0[1]	gpio0[0]	00h
0C	R/W	GPIO1 Configuration	gpio1drv[1]	gpio1drv[0]	pup1	gpio1[4]	gpio1[3]	gpio1[2]	gpio1[1]	gpio1[0]	00h
0D	R/W	GPIO2 Configuration	gpio2drv[1]	gpio2drv[0]	pup2	gpio2[4]	gpio2[3]	gpio2[2]	gpio2[1]	gpio2[0]	00h
0E	R/W	I/O Port Configuration		extitst[2]	extitst[1]	extitst[0]	itsdo	dio2	dio1	dio0	00h

The GPIO settings for GPIO1 and GPIO2 are the same as for GPIO0 with the exception of the 00000 default setting. The default settings for each GPIO are listed below:

GPIO	00000—Default Setting
GPIO0	POR
GPIO1	POR Inverted
GPIO2	Output Clock

For a complete list of the available GPIOs see “AN440: EZRadioPRO Detailed Register Descriptions”.

The GPIO drive strength may be adjusted with the $gpioXdrv[1:0]$ bits. Setting a higher value will increase the drive strength and current capability of the GPIO by changing the driver size. Special care should be

taken in setting the drive strength and loading on GPIO2 when the microcontroller clock is used. Excess loading or inadequate drive may contribute to increased spurious emissions.

Pin 6, ANT may be used as an alternate to control a TR switch. Pin 6 is a hardwired version of GPIO setting 11000, Antenna 2 Switch used for antenna diversity. It can be manually controlled by the antdiv[2:0] bits in register 08h if antenna diversity is not used. See AN440, register 08h for more details.

32.8.9. Antenna Diversity

To mitigate the problem of frequency-selective fading due to multi-path propagation, some transceiver systems use a scheme known as antenna diversity. In this scheme, two antennas are used. Each time the transceiver enters RX mode the receive signal strength from each antenna is evaluated. This evaluation process takes place during the preamble portion of the packet. The antenna with the strongest received signal is then used for the remainder of that RX packet. The same antenna will also be used for the next corresponding TX packet.

This chip fully supports antenna diversity with an integrated antenna diversity control algorithm. The required signals needed to control an external SPDT RF switch (such as PIN diode or GaAs switch) are available on the GPIOx pins. The operation of these GPIO signals is programmable to allow for different antenna diversity architectures and configurations. The antdiv[2:0] bits are found in register 08h "Operating & Function Control 2." The GPIO pins are capable of sourcing up to 5 mA of current, so it may be used directly to forward-bias a PIN diode if desired.

The antenna diversity algorithm will automatically toggle back and forth between the antennas until the packet starts to arrive. The recommended preamble length for optimal antenna selection is 8 bytes. A special antenna diversity algorithm (antdiv[2:0] = 110 or 111) is included that allows for shorter preamble lengths for beacon mode in TDMA-like systems where the arrival of the packet is synchronous to the receiver enable. The recommended preamble length to obtain optimal antenna selection for synchronous mode is 4 bytes.

Add	R/W	Function/Description	D7	D6	D5	D4	D3	D2	D1	D0	POR Def.
08	R/W	Operating & Function Control 2	antdiv[2]	antdiv[1]	antdiv[0]	rxmpk	autotx	enldm	ffclrx	ffcltx	00h

Table 32.8. Antenna Diversity Control

antdiv[2:0]	RX/TX State		Non RX/TX State	
	GPIO Ant1	GPIO Ant2	GPIO Ant1	GPIO Ant2
000	0	1	0	0
001	1	0	0	0
010	0	1	1	1
011	1	0	1	1
100	Antenna Diversity Algorithm		0	0
101	Antenna Diversity Algorithm		1	1
110	Antenna Diversity Algorithm in Beacon Mode		0	0
111	Antenna Diversity Algorithm in Beacon Mode		1	1

32.8.10. RSSI and Clear Channel Assessment

Received signal strength indicator (RSSI) is an estimate of the signal strength in the channel to which the receiver is tuned. The RSSI value can be read from an 8-bit register with 0.5 dB resolution per bit. Figure 32.25 demonstrates the relationship between input power level and RSSI value. The absolute value of the RSSI will change slightly depending on the modem settings. The RSSI may be read at anytime, but

Si102x/3x

an incorrect error may rarely occur. The RSSI value may be incorrect if read during the update period. The update period is approximately 10 ns every 4 Tb. For 10 kbps, this would result in a 1 in 40,000 probability that the RSSI may be read incorrectly. This probability is extremely low, but to avoid this, one of the following options is recommended: majority polling, reading the RSSI value within 1 Tb of the RSSI interrupt, or using the RSSI threshold described in the next paragraph for Clear Channel Assessment (CCA).

Add	R/W	Function/Description	D7	D6	D5	D4	D3	D2	D1	D0	POR Def.
26	R	Received Signal Strength Indicator	rssif[7]	rssif[6]	rssif[5]	rssif[4]	rssif[3]	rssif[2]	rssif[1]	rssif[0]	—
27	R/W	RSSI Threshold for Clear Channel Indicator	rssith[7]	rssith[6]	rssith[5]	rssith[4]	rssith[3]	rssith[2]	rssith[1]	rssith[0]	00h

For CCA, threshold is programmed into rssith[7:0] in "Register 27h. RSSI Threshold for Clear Channel Indicator." After the RSSI is evaluated in the preamble, a decision is made if the signal strength on this channel is above or below the threshold. If the signal strength is above the programmed threshold then the RSSI status bit, irssi, in "Register 04h. Interrupt/Status 2" will be set to 1. The RSSI status can also be routed to a GPIO line by configuring the GPIO configuration register to GPIOx[3:0] = 1110.

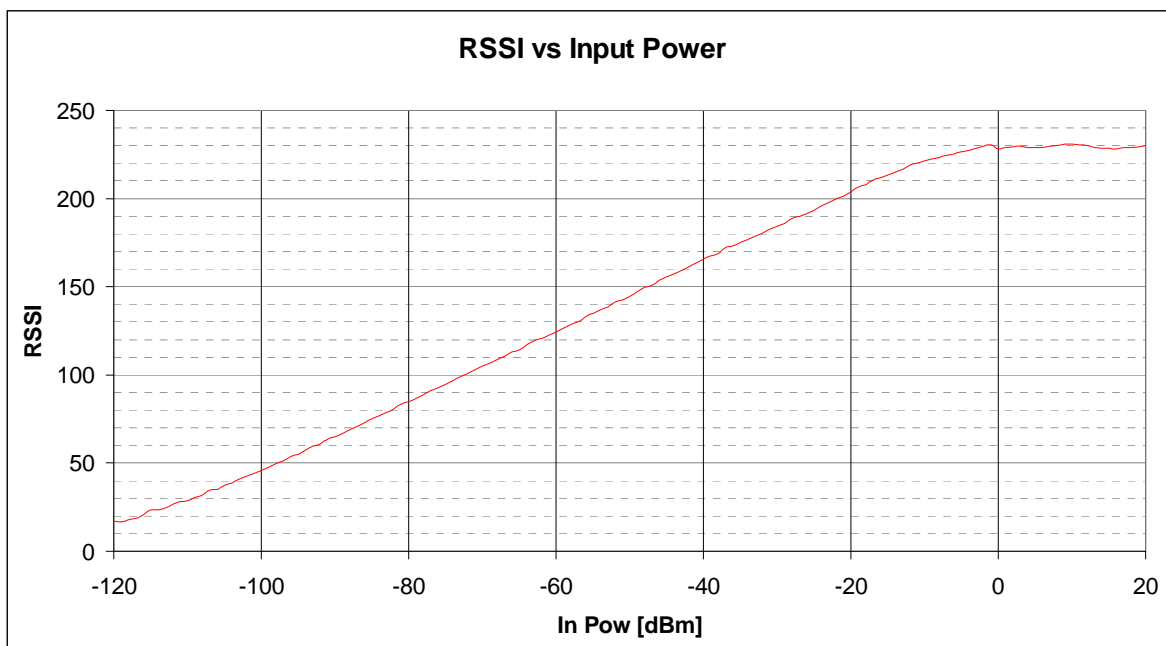

Figure 32.25. RSSI Value vs. Input Power

32.9. Reference Design

Reference designs are available at www.silabs.com for many common applications which include recommended schematics, BOM, and layout. TX matching component values for the different frequency bands can be found in the application notes "AN435: Si4032/4432 PA Matching" and "AN436: Si4030/4031/4430/4431 PA Matching." RX matching component values for different frequency bands can be found in "AN427: EZRadioPRO Si433x and Si443x RX LNA Matching."

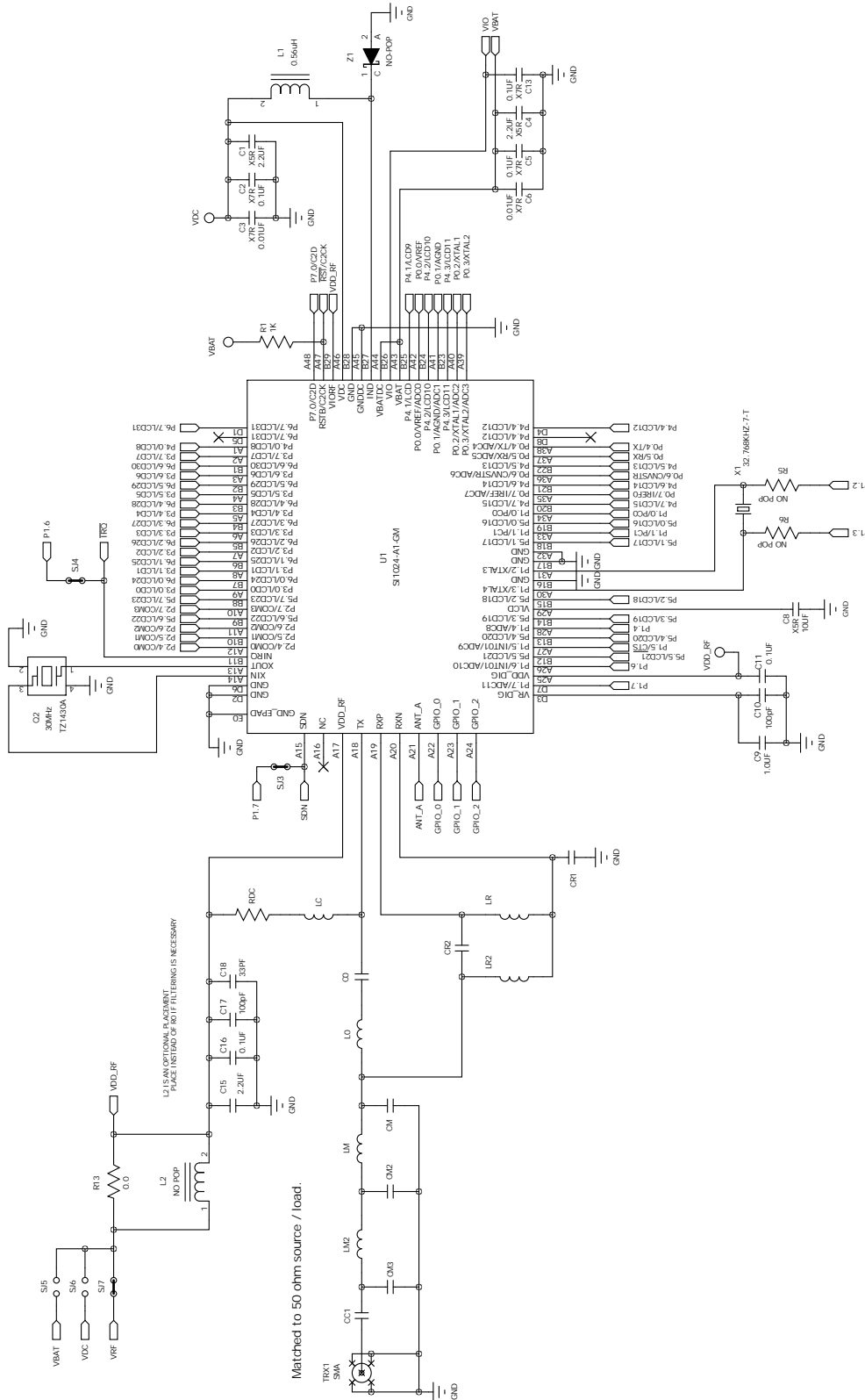

Figure 32.26. Si1024 Split RF TX/RX Direct-Tie Reference Design—Schematic

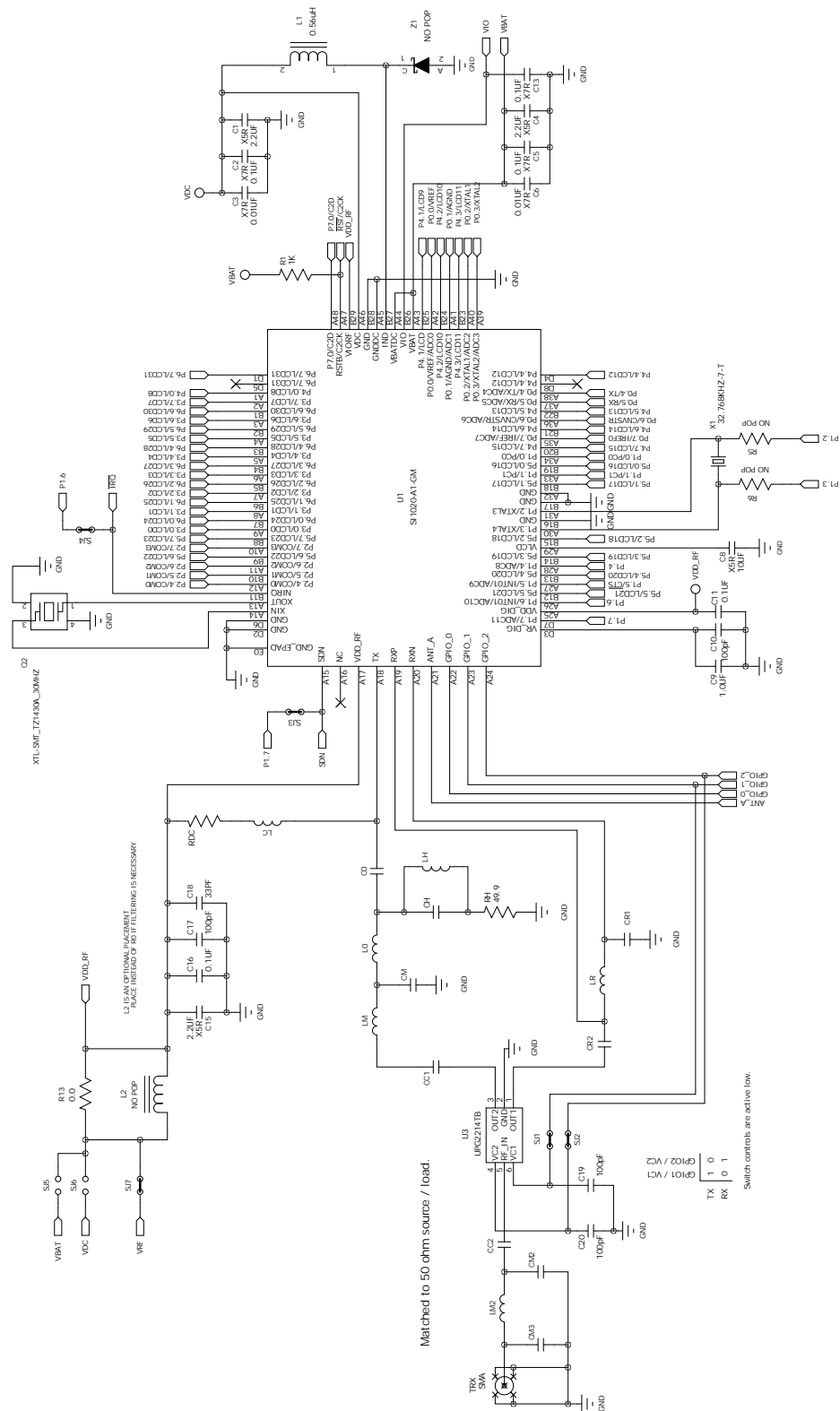

Figure 32.27. Si1020 Switch Matching Reference Design—Schematic

32.10. Application Notes and Reference Designs

A comprehensive set of application notes and reference designs are available to assist with the development of a radio system. A partial list of applications notes is given below.

For the complete list of application notes, latest reference designs and demos visit the [Silicon Labs website](#).

- AN361: Wireless MBUS Implementation using EZRadioPRO Devices
- AN379: Antenna Diversity with EZRadioPRO
- AN414: EZRadioPRO Layout Design Guide
- AN415: EZRadioPRO Programming Guide
- AN417: Si4x3x Family Crystal Oscillators
- AN419: ARIB STD-T67 Narrow-Band 426/429 MHz Measured on the Si4431-A0
- AN427: EZRadioPRO Si433x and Si443x RX LNA Matching
- AN429: Using the DC-DC Converter on the F9xx Series MCU for Single Battery Operation with the EZRadioPRO RF Devices
- AN432: RX BER Measurement on EZRadioPRO with a Looped PN Sequence
- AN435: Si4032/4432 PA Matching
- AN436: Si4030/4031/4430/4431 PA Matching
- AN437: 915 MHz Measurement Results and FCC Compliance
- AN439: EZRadioPRO Quick Start Guide
- AN440: Si4430/31/32 Register Descriptions
- AN445: Si4431 RF Performance and ETSI Compliance Test Results
- AN451: Wireless M-BUS Software Implementation
- AN459: 950 MHz Measurement Results and ARIB Compliance
- AN460: 470 MHz Measurement Results for China
- AN463: Support for Non-Standard Packet Structures and RAW Mode
- AN466: Si4030/31/32 Register Descriptions
- AN467: Si4330 Register Descriptions
- AN514: Using the EZLink Reference Design to Create a Two-Channel PWM Motor Control Circuit
- AN539: EZMacPRO Overview

32.11. Customer Support

Technical support for the complete family of Silicon Labs wireless products is available by accessing the wireless section of the Silicon Labs' website at www.silabs.com/wireless. For MCU support, please visit www.silabs.com/mcu.

For answers to common questions please visit the wireless and mcu knowledge base at www.silabs.com/support/knowledgebase.

32.12. Register Table and Descriptions

Table 32.9. EZRadioPRO Internal Register Descriptions

Add	R/W	Function/Desc	Data								POR Default
			D7	D6	D5	D4	D3	D2	D1	D0	
00	R	Device Type	0	0	0	dt[4]	dt[3]	dt[2]	dt[1]	dt[0]	0011h
01	R	Device Version	0	0	0	vc[4]	vc[3]	vc[2]	vc[1]	vc[0]	06h
02	R	Device Status	ffovfl	ffunfl	rxffem	headerr	reserved	reserved	cps[1]	cps[0]	—
03	R	Interrupt Status 1	ifferr	itxffaull	itxffaem	irxffaull	iext	ipksent	ipkvalid	icrcerror	—
04	R	Interrupt Status 2	iswdet	ipreaval	ipreainval	irssi	iwut	ilbd	ichiprdy	ipor	—
05	R/W	Interrupt Enable 1	enfferr	entxffaull	entxffaem	enrxffaull	enext	enpksent	enpkvalid	encrcerror	00h
06	R/W	Interrupt Enable 2	enswdet	enpreaval	enpreainval	enrssi	enwut	enlbd	enchiprdy	enpor	03h
07	R/W	Operating & Function Control 1	swres	enlbd	enwt	x32ksel	txon	rxon	pllon	xton	01h
08	R/W	Operating & Function Control 2	antdiv[2]	antdiv[1]	antdiv[0]	rxmpk	autotx	enldm	ffclrx	ffclrtx	00h
09	R/W	Crystal Oscillator Load Capacitance	xtalshft	xlcf[6]	xlcf[5]	xlcf[4]	xlcf[3]	xlcf[2]	xlcf[1]	xlcf[0]	7Fh
0A	R/W	Microcontroller Output Clock	Reserved	Reserved	clkt[1]	clkt[0]	enlfc	mclk[2]	mclk[1]	mclk[0]	06h
0B	R/W	GPIO0 Configuration	gpio0drv[1]	gpio0drv[0]	pup0	gpio0[4]	gpio0[3]	gpio0[2]	gpio0[1]	gpio0[0]	00h
0C	R/W	GPIO1 Configuration	gpio1drv[1]	gpio1drv[0]	pup1	gpio1[4]	gpio1[3]	gpio1[2]	gpio1[1]	gpio1[0]	00h
0D	R/W	GPIO2 Configuration	gpio2drv[1]	gpio2drv[0]	pup2	gpio2[4]	gpio2[3]	gpio2[2]	gpio2[1]	gpio2[0]	00h
0E	R/W	I/O Port Configuration	Reserved	extitst[2]	extitst[1]	extitst[0]	itsdo	dio2	dio1	dio0	00h
0F	R/W	ADC Configuration	adcstart/ <i>adc-done</i>	adcsl[2]	adcsl[1]	adcsl[0]	adcref[1]	adcref[0]	adcgain[1]	adcgain[0]	00h
10	R/W	ADC Sensor Amplifier Offset	Reserved	Reserved	Reserved	Reserved	adcoffs[3]	adcoffs[2]	adcoffs[1]	adcoffs[0]	00h
11	R	ADC Value	adc[7]	adc[6]	adc[5]	adc[4]	adc[3]	adc[2]	adc[1]	adc[0]	—
12	R/W	Temperature Sensor Control	tsrange[1]	tsrange[0]	entsoffs	entstrim	tstrim[3]	tstrim[2]	tstrim[1]	tstrim[0]	20h
13	R/W	Temperature Value Offset	tvoffs[7]	tvoffs[6]	tvoffs[5]	tvoffs[4]	tvoffs[3]	tvoffs[2]	tvoffs[1]	tvoffs[0]	00h
14	R/W	Wake-Up Timer Period 1	Reserved	Reserved	Reserved	wtr[4]	wtr[3]	wtr[2]	wtr[1]	wtr[0]	03h
15	R/W	Wake-Up Timer Period 2	wtm[15]	wtm[14]	wtm[13]	wtm[12]	wtm[11]	wtm[10]	wtm[9]	wtm[8]	00h
16	R/W	Wake-Up Timer Period 3	wtm[7]	wtm[6]	wtm[5]	wtm[4]	wtm[3]	wtm[2]	wtm[1]	wtm[0]	01h
17	R	Wake-Up Timer Value 1	wtv[15]	wtv[14]	wtv[13]	wtv[12]	wtv[11]	wtv[10]	wtv[9]	wtv[8]	—
18	R	Wake-Up Timer Value 2	wtv[7]	wtv[6]	wtv[5]	wtv[4]	wtv[3]	wtv[2]	wtv[1]	wtv[0]	—
19	R/W	Low-Duty Cycle Mode Duration	ldc[7]	ldc[6]	ldc[5]	ldc[4]	ldc[3]	ldc[2]	ldc[1]	ldc[0]	00h
1A	R/W	Low Battery Detector Threshold	Reserved	Reserved	Reserved	lbd[4]	lbd[3]	lbd[2]	lbd[1]	lbd[0]	14h
1B	R	Battery Voltage Level	0	0	0	vbat[4]	vbat[3]	vbat[2]	vbat[1]	vbat[0]	—
1C	R/W	IF Filter Bandwidth	dwn3_bypass	ndec[2]	ndec[1]	ndec[0]	filset[3]	filset[2]	filset[1]	filset[0]	01h
1D	R/W	AFC Loop Gearshift Override	afcbd	enafc	afcgearh[2]	afcgearh[1]	afcgearh[0]	1p5 bypass	matap	ph0size	40h
1E	R/W	AFC Timing Control	swait_timer[1]	swait_timer[0]	shwait[2]	shwait[1]	shwait[0]	anwait[2]	anwait[1]	anwait[0]	0Ah
1F	R/W	Clock Recovery Gearshift Override	Reserved	Reserved	crfast[2]	crfast[1]	crfast[0]	crslow[2]	crslow[1]	crslow[0]	03h
20	R/W	Clock Recovery Oversampling Ratio	rxosr[7]	rxosr[6]	rxosr[5]	rxosr[4]	rxosr[3]	rxosr[2]	rxosr[1]	rxosr[0]	64h
21	R/W	Clock Recovery Offset 2	rxosr[10]	rxosr[9]	rxosr[8]	stallctrl	ncoff[19]	ncoff[18]	ncoff[17]	ncoff[16]	01h
22	R/W	Clock Recovery Offset 1	ncoff[15]	ncoff[14]	ncoff[13]	ncoff[12]	ncoff[11]	ncoff[10]	ncoff[9]	ncoff[8]	47h
23	R/W	Clock Recovery Offset 0	ncoff[7]	ncoff[6]	ncoff[5]	ncoff[4]	ncoff[3]	ncoff[2]	ncoff[1]	ncoff[0]	AEh
24	R/W	Clock Recovery Timing Loop Gain 1	Reserved	Reserved	Reserved	rxnocomp	rgain2x	rgain[10]	rgain[9]	rgain[8]	02h
25	R/W	Clock Recovery Timing Loop Gain 0	rgain[7]	rgain[6]	rgain[5]	rgain[4]	rgain[3]	rgain[2]	rgain[1]	rgain[0]	8Fh
26	R	Received Signal Strength Indicator	rss[7]	rss[6]	rss[5]	rss[4]	rss[3]	rss[2]	rss[1]	rss[0]	—
27	R/W	RSSI Threshold for Clear Channel Indicator	rssith[7]	rssith[6]	rssith[5]	rssith[4]	rssith[3]	rssith[2]	rssith[1]	rssith[0]	1Eh
28	R	Antenna Diversity Register 1	adrssi[7]	adrssia[6]	adrssia[5]	adrssia[4]	adrssia[3]	adrssia[2]	adrssia[1]	adrssia[0]	—
29	R	Antenna Diversity Register 2	adrssib[7]	adrssib[6]	adrssib[5]	adrssib[4]	adrssib[3]	adrssib[2]	adrssib[1]	adrssib[0]	—
2A	R/W	AFC Limiter	Afclim[7]	Afclim[6]	Afclim[5]	Afclim[4]	Afclim[3]	Afclim[2]	Afclim[1]	Afclim[0]	00h
2B	R	AFC Correction Read	afc_corr[9]	afc_corr[8]	afc_corr[7]	afc_corr[6]	afc_corr[5]	afc_corr[4]	afc_corr[3]	afc_corr[2]	00h
2C	R/W	OOK Counter Value 1	afc_corr[9]	afc_corr[9]	ookfrzen	peakdeten	madeten	ookcnt[10]	ookcnt[9]	ookcnt[8]	18h
2D	R/W	OOK Counter Value 2	ookcnt[7]	ookcnt[6]	ookcnt[5]	ookcnt[4]	ookcnt[3]	ookcnt[2]	ookcnt[1]	ookcnt[0]	BCh
2E	R/W	Slicer Peak Hold	Reserved	attack[2]	attack[1]	attack[0]	decay[3]	decay[2]	decay[1]	decay[0]	26h
2F			Reserved								

Table 32.9. EZRadioPRO Internal Register Descriptions (Continued)

Add	R/W	Function/Desc	Data								POR Default
			D7	D6	D5	D4	D3	D2	D1	D0	
30	R/W	Data Access Control	enpacrx	lsbfrst	crcconly	skip2ph	enpactx	encrc	crc[1]	crc[0]	8Dh
31	R	EzMAC status	0	rxrcr1	pkrsrch	pkrx	pkvalid	crcerror	pktx	pkstent	—
32	R/W	Header Control 1	bcen[3:0]				hdch[3:0]				0Ch
33	R/W	Header Control 2	skipsyn	hdlen[2]	hdlen[1]	hdlen[0]	fixpklen	synclen[1]	synclen[0]	prealen[8]	22h
34	R/W	Preamble Length	prealen[7]	prealen[6]	prealen[5]	prealen[4]	prealen[3]	prealen[2]	prealen[1]	prealen[0]	08h
35	R/W	Preamble Detection Control	preath[4]	preath[3]	preath[2]	preath[1]	preath[0]	rssloff[2]	rssloff[1]	rssloff[0]	2Ah
36	R/W	Sync Word 3	sync[31]	sync[30]	sync[29]	sync[28]	sync[27]	sync[26]	sync[25]	sync[24]	2Dh
37	R/W	Sync Word 2	sync[23]	sync[22]	sync[21]	sync[20]	sync[19]	sync[18]	sync[17]	sync[16]	D4h
38	R/W	Sync Word 1	sync[15]	sync[14]	sync[13]	sync[12]	sync[11]	sync[10]	sync[9]	sync[8]	00h
39	R/W	Sync Word 0	sync[7]	sync[6]	sync[5]	sync[4]	sync[3]	sync[2]	sync[1]	sync[0]	00h
3A	R/W	Transmit Header 3	txhd[31]	txhd[30]	txhd[29]	txhd[28]	txhd[27]	txhd[26]	txhd[25]	txhd[24]	00h
3B	R/W	Transmit Header 2	txhd[23]	txhd[22]	txhd[21]	txhd[20]	txhd[19]	txhd[18]	txhd[17]	txhd[16]	00h
3C	R/W	Transmit Header 1	txhd[15]	txhd[14]	txhd[13]	txhd[12]	txhd[11]	txhd[10]	txhd[9]	txhd[8]	00h
3D	R/W	Transmit Header 0	txhd[7]	txhd[6]	txhd[5]	txhd[4]	txhd[3]	txhd[2]	txhd[1]	txhd[0]	00h
3E	R/W	Transmit Packet Length	pklen[7]	pklen[6]	pklen[5]	pklen[4]	pklen[3]	pklen[2]	pklen[1]	pklen[0]	00h
3F	R/W	Check Header 3	chhd[31]	chhd[30]	chhd[29]	chhd[28]	chhd[27]	chhd[26]	chhd[25]	chhd[24]	00h
40	R/W	Check Header 2	chhd[23]	chhd[22]	chhd[21]	chhd[20]	chhd[19]	chhd[18]	chhd[17]	chhd[16]	00h
41	R/W	Check Header 1	chhd[15]	chhd[14]	chhd[13]	chhd[12]	chhd[11]	chhd[10]	chhd[9]	chhd[8]	00h
42	R/W	Check Header 0	chhd[7]	chhd[6]	chhd[5]	chhd[4]	chhd[3]	chhd[2]	chhd[1]	chhd[0]	00h
43	R/W	Header Enable 3	hden[31]	hden[30]	hden[29]	hden[28]	hden[27]	hden[26]	hden[25]	hden[24]	FFh
44	R/W	Header Enable 2	hden[23]	hden[22]	hden[21]	hden[20]	hden[19]	hden[18]	hden[17]	hden[16]	FFh
45	R/W	Header Enable 1	hden[15]	hden[14]	hden[13]	hden[12]	hden[11]	hden[10]	hden[9]	hden[8]	FFh
46	R/W	Header Enable 0	hden[7]	hden[6]	hden[5]	hden[4]	hden[3]	hden[2]	hden[1]	hden[0]	FFh
47	R	Received Header 3	rxhd[31]	rxhd[30]	rxhd[29]	rxhd[28]	rxhd[27]	rxhd[26]	rxhd[25]	rxhd[24]	—
48	R	Received Header 2	rxhd[23]	rxhd[22]	rxhd[21]	rxhd[20]	rxhd[19]	rxhd[18]	rxhd[17]	rxhd[16]	—
49	R	Received Header 1	rxhd[15]	rxhd[14]	rxhd[13]	rxhd[12]	rxhd[11]	rxhd[10]	rxhd[9]	rxhd[8]	—
4A	R	Received Header 0	rxhd[7]	rxhd[6]	rxhd[5]	rxhd[4]	rxhd[3]	rxhd[2]	rxhd[1]	rxhd[0]	—
4B	R	Received Packet Length	rxplen[7]	rxplen[6]	rxplen[5]	rxplen[4]	rxplen[3]	rxplen[2]	rxplen[1]	rxplen[0]	—
4C-4E			Reserved								
4F	R/W	ADC8 Control	Reserved	Reserved	adc8[5]	adc8[4]	adc8[3]	adc8[2]	adc8[1]	adc8[0]	10h
50-5F			Reserved								
60	R/W	Channel Filter Coefficient Address	Inv_pre_th[3]	Inv_pre_th[2]	Inv_pre_th[1]	Inv_pre_th[0]	chfiladd[3]	chfiladd[2]	chfiladd[1]	chfiladd[0]	00h
61			Reserved								
62	R/W	Crystal Oscillator/ Control Test	pwst[2]	pwst[1]	pwst[0]	clkhyst	enbias2x	enamp2x	bufovr	enbuf	24h
63-6C			Reserved								
6D	R/W	TX Power	Reserved	Reserved	Reserved	Reserved	lna_sw	txpow[2]	txpow[1]	txpow[0]	18h
6E	R/W	TX Data Rate 1	txdr[15]	txdr[14]	txdr[13]	txdr[12]	txdr[11]	txdr[10]	txdr[9]	txdr[8]	0Ah
6F	R/W	TX Data Rate 0	txdr[7]	txdr[6]	txdr[5]	txdr[4]	txdr[3]	txdr[2]	txdr[1]	txdr[0]	3Dh
70	R/W	Modulation Mode Control 1	Reserved	Reserved	txdtrtscale	enphpwbn	manppol	enmaninv	enmanch	enwhite	0Ch
71	R/W	Modulation Mode Control 2	trclk[1]	trclk[0]	dtmod[1]	dtmod[0]	eninv	fd[8]	modtyp[1]	modtyp[0]	00h
72	R/W	Frequency Deviation	fd[7]	fd[6]	fd[5]	fd[4]	fd[3]	fd[2]	fd[1]	fd[0]	20h
73	R/W	Frequency Offset 1	fo[7]	fo[6]	fo[5]	fo[4]	fo[3]	fo[2]	fo[1]	fo[0]	00h
74	R/W	Frequency Offset 2	Reserved	Reserved	Reserved	Reserved	Reserved	Reserved	fo[9]	fo[8]	00h
75	R/W	Frequency Band Select	Reserved	sbsel	hbsel	fb[4]	fb[3]	fb[2]	fb[1]	fb[0]	75h
76	R/W	Nominal Carrier Frequency 1	fc[15]	fc[14]	fc[13]	fc[12]	fc[11]	fc[10]	fc[9]	fc[8]	BBh
77	R/W	Nominal Carrier Frequency 0	fc[7]	fc[6]	fc[5]	fc[4]	fc[3]	fc[2]	fc[1]	fc[0]	80h
78			Reserved								
79	R/W	Frequency Hopping Channel Select	fhch[7]	fhch[6]	fhch[5]	fhch[4]	fhch[3]	fhch[2]	fhch[1]	fhch[0]	00h
7A	R/W	Frequency Hopping Step Size	fhs[7]	fhs[6]	fhs[5]	fhs[4]	fhs[3]	fhs[2]	fhs[1]	fhs[0]	00h
7B			Reserved								
7C	R/W	TX FIFO Control 1	Reserved	Reserved	txafthr[5]	txafthr[4]	txafthr[3]	txafthr[2]	txafthr[1]	txafthr[0]	37h
7D	R/W	TX FIFO Control 2	Reserved	Reserved	txaethr[5]	txaethr[4]	txaethr[3]	txaethr[2]	txaethr[1]	txaethr[0]	04h
7E	R/W	RX FIFO Control	Reserved	Reserved	rxafthr[5]	rxafthr[4]	rxafthr[3]	rxafthr[2]	rxafthr[1]	rxafthr[0]	37h
7F	R/W	FIFO Access	fifod[7]	fifod[6]	fifod[5]	fifod[4]	fifod[3]	fifod[2]	fifod[1]	fifod[0]	—

Note: Detailed register descriptions are available in “AN440: EZRadioPRO Detailed Register Descriptions.”

32.13. Required Changes to Default Register Values

The following register writes should be performed during device initialization.

1. The value 0x40 should be written to Register 59h.
2. If the device will be operated in the 240–320 MHz or 480–640 MHz bands at a temperature above 60 °C, then Register 59h should be written to 0x43 and Register 5Ah should be written to 0x02.

33. Timers

Each MCU includes four counter/timers: two are 16-bit counter/timers compatible with those found in the standard 8051, and two are 16-bit auto-reload timer for use with the ADC, SMBus, or for general purpose use. These timers can be used to measure time intervals, count external events and generate periodic interrupt requests. Timer 0 and Timer 1 are nearly identical and have four primary modes of operation. Timer 2 and Timer 3 offer 16-bit and split 8-bit timer functionality with auto-reload. Additionally, Timer 2 and Timer 3 have a Capture Mode that can be used to measure the SmarTClock, Comparator, or external clock period with respect to another oscillator. The ability to measure the Comparator period with respect to another oscillator is particularly useful when interfacing to capacitive sensors.

Timer 0 and Timer 1 Modes:	Timer 2 Modes:	Timer 3 Modes:
13-bit counter/timer	16-bit timer with auto-reload	16-bit timer with auto-reload
16-bit counter/timer		
8-bit counter/timer with auto-reload	Two 8-bit timers with auto-reload	Two 8-bit timers with auto-reload
Two 8-bit counter/timers (Timer 0 only)		

Timers 0 and 1 may be clocked by one of five sources, determined by the Timer Mode Select bits (T1M–T0M) and the Clock Scale bits (SCA1–SCA0). The Clock Scale bits define a pre-scaled clock from which Timer 0 and/or Timer 1 may be clocked (See SFR Definition 33.1 for pre-scaled clock selection).

Timer 0/1 may then be configured to use this pre-scaled clock signal or the system clock. Timer 2 and Timer 3 may be clocked by the system clock, the system clock divided by 12. Timer 2 may additionally be clocked by the SmarTClock divided by 8 or the Comparator0 output. Timer 3 may additionally be clocked by the external oscillator clock source divided by 8 or the Comparator1 output.

Timer 0 and Timer 1 may also be operated as counters. When functioning as a counter, a counter/timer register is incremented on each high-to-low transition at the selected input pin (T0 or T1). Events with a frequency of up to one-fourth the system clock frequency can be counted. The input signal need not be periodic, but it should be held at a given level for at least two full system clock cycles to ensure the level is properly sampled.

SFR Definition 33.1. CKCON: Clock Control

Bit	7	6	5	4	3	2	1	0
Name	T3MH	T3ML	T2MH	T2ML	T1M	T0M	SCA[1:0]	
Type	R/W	R/W	R/W	R/W	R/W	R/W	R/W	
Reset	0	0	0	0	0	0	0	0

SFR Page = 0x0; SFR Address = 0x8E

Bit	Name	Function
7	T3MH	Timer 3 High Byte Clock Select. Selects the clock supplied to the Timer 3 high byte (split 8-bit timer mode only). 0: Timer 3 high byte uses the clock defined by the T3XCLK bit in TMR3CN. 1: Timer 3 high byte uses the system clock.
6	T3ML	Timer 3 Low Byte Clock Select. Selects the clock supplied to Timer 3. Selects the clock supplied to the lower 8-bit timer in split 8-bit timer mode. 0: Timer 3 low byte uses the clock defined by the T3XCLK bit in TMR3CN. 1: Timer 3 low byte uses the system clock.
5	T2MH	Timer 2 High Byte Clock Select. Selects the clock supplied to the Timer 2 high byte (split 8-bit timer mode only). 0: Timer 2 high byte uses the clock defined by the T2XCLK bit in TMR2CN. 1: Timer 2 high byte uses the system clock.
4	T2ML	Timer 2 Low Byte Clock Select. Selects the clock supplied to Timer 2. If Timer 2 is configured in split 8-bit timer mode, this bit selects the clock supplied to the lower 8-bit timer. 0: Timer 2 low byte uses the clock defined by the T2XCLK bit in TMR2CN. 1: Timer 2 low byte uses the system clock.
3	T1M	Timer 1 Clock Select. Selects the clock source supplied to Timer 1. Ignored when C/T1 is set to 1. 0: Timer 1 uses the clock defined by the prescale bits SCA[1:0]. 1: Timer 1 uses the system clock.
2	T0M	Timer 0 Clock Select. Selects the clock source supplied to Timer 0. Ignored when C/T0 is set to 1. 0: Counter/Timer 0 uses the clock defined by the prescale bits SCA[1:0]. 1: Counter/Timer 0 uses the system clock.
1:0	SCA[1:0]	Timer 0/1 Prescale Bits. These bits control the Timer 0/1 Clock Prescaler: 00: System clock divided by 12 01: System clock divided by 4 10: System clock divided by 48 11: External clock divided by 8 (synchronized with the system clock)

33.1. Timer 0 and Timer 1

Each timer is implemented as a 16-bit register accessed as two separate bytes: a low byte (TL0 or TL1) and a high byte (TH0 or TH1). The Counter/Timer Control register (TCON) is used to enable Timer 0 and Timer 1 as well as indicate status. Timer 0 interrupts can be enabled by setting the ET0 bit in the IE register (Section “17.5. Interrupt Register Descriptions” on page 241); Timer 1 interrupts can be enabled by setting the ET1 bit in the IE register (Section “17.5. Interrupt Register Descriptions” on page 241). Both counter/timers operate in one of four primary modes selected by setting the Mode Select bits T1M1–T0M0 in the Counter/Timer Mode register (TMOD). Each timer can be configured independently. Each operating mode is described below.

33.1.1. Mode 0: 13-bit Counter/Timer

Timer 0 and Timer 1 operate as 13-bit counter/timers in Mode 0. The following describes the configuration and operation of Timer 0. However, both timers operate identically, and Timer 1 is configured in the same manner as described for Timer 0.

The TH0 register holds the eight MSBs of the 13-bit counter/timer. TL0 holds the five LSBs in bit positions TL0.4–TL0.0. The three upper bits of TL0 (TL0.7–TL0.5) are indeterminate and should be masked out or ignored when reading. As the 13-bit timer register increments and overflows from 0x1FFF (all ones) to 0x0000, the timer overflow flag TF0 (TCON.5) is set and an interrupt will occur if Timer 0 interrupts are enabled.

The C/T0 bit (TMOD.2) selects the counter/timer's clock source. When C/T0 is set to logic 1, high-to-low transitions at the selected Timer 0 input pin (T0) increment the timer register (Refer to Section “27.3. Priority Crossbar Decoder” on page 362 for information on selecting and configuring external I/O pins). Clearing C/T selects the clock defined by the T0M bit (CKCON.3). When T0M is set, Timer 0 is clocked by the system clock. When T0M is cleared, Timer 0 is clocked by the source selected by the Clock Scale bits in CKCON (see SFR Definition 33.1).

Setting the TR0 bit (TCON.4) enables the timer when either GATE0 (TMOD.3) is logic 0 or the input signal $\overline{\text{INT0}}$ is active as defined by bit IN0PL in register IT01CF (see SFR Definition 17.7). Setting GATE0 to 1 allows the timer to be controlled by the external input signal $\overline{\text{INT0}}$ (see Section “17.5. Interrupt Register Descriptions” on page 241), facilitating pulse width measurements

Table 33.1. Timer 0 Running Modes

TR0	GATE0	$\overline{\text{INT0}}$	Counter/Timer
0	X	X	Disabled
1	0	X	Enabled
1	1	0	Disabled
1	1	1	Enabled

Note: X = Don't Care

Setting TR0 does not force the timer to reset. The timer registers should be loaded with the desired initial value before the timer is enabled.

TL1 and TH1 form the 13-bit register for Timer 1 in the same manner as described above for TL0 and TH0. Timer 1 is configured and controlled using the relevant TCON and TMOD bits just as with Timer 0. The input signal INT1 is used with Timer 1; the INT1 polarity is defined by bit IN1PL in register IT01CF (see SFR Definition 17.7).

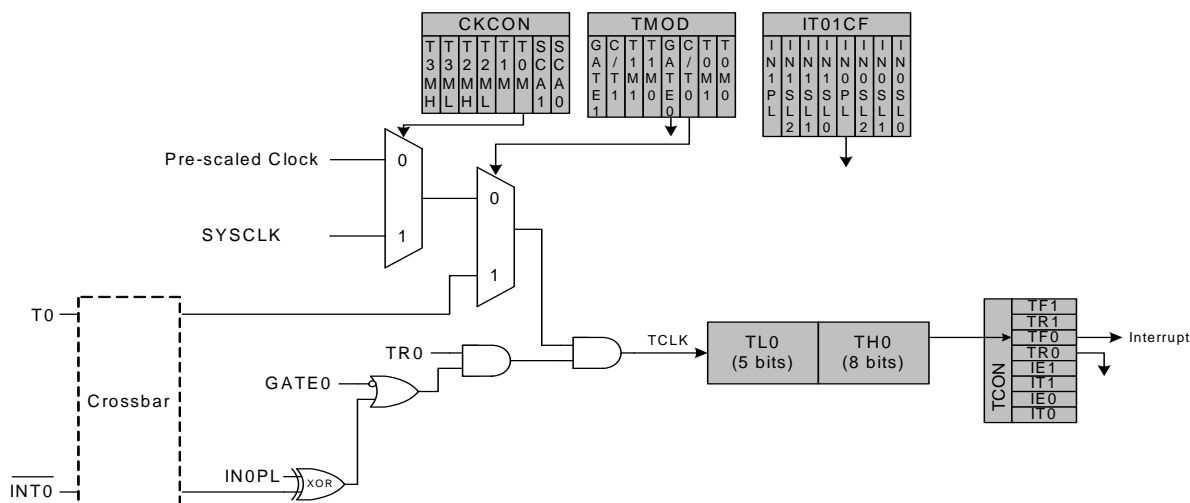

Figure 33.1. T0 Mode 0 Block Diagram

33.1.2. Mode 1: 16-bit Counter/Timer

Mode 1 operation is the same as Mode 0, except that the counter/timer registers use all 16 bits. The counter/timers are enabled and configured in Mode 1 in the same manner as for Mode 0.

33.1.3. Mode 2: 8-bit Counter/Timer with Auto-Reload

Mode 2 configures Timer 0 and Timer 1 to operate as 8-bit counter/timers with automatic reload of the start value. TL0 holds the count and TH0 holds the reload value. When the counter in TL0 overflows from all ones to 0x00, the timer overflow flag TF0 (TCON.5) is set and the counter in TL0 is reloaded from TH0. If Timer 0 interrupts are enabled, an interrupt will occur when the TF0 flag is set. The reload value in TH0 is not changed. TL0 must be initialized to the desired value before enabling the timer for the first count to be correct. When in Mode 2, Timer 1 operates identically to Timer 0.

Both counter/timers are enabled and configured in Mode 2 in the same manner as Mode 0. Setting the TR0 bit (TCON.4) enables the timer when either GATE0 (TMOD.3) is logic 0 or when the input signal $\overline{\text{INT0}}$ is active as defined by bit IN0PL in register IT01CF (see Section “17.6. External Interrupts INT0 and INT1” on page 248 for details on the external input signals $\overline{\text{INT0}}$ and INT1).

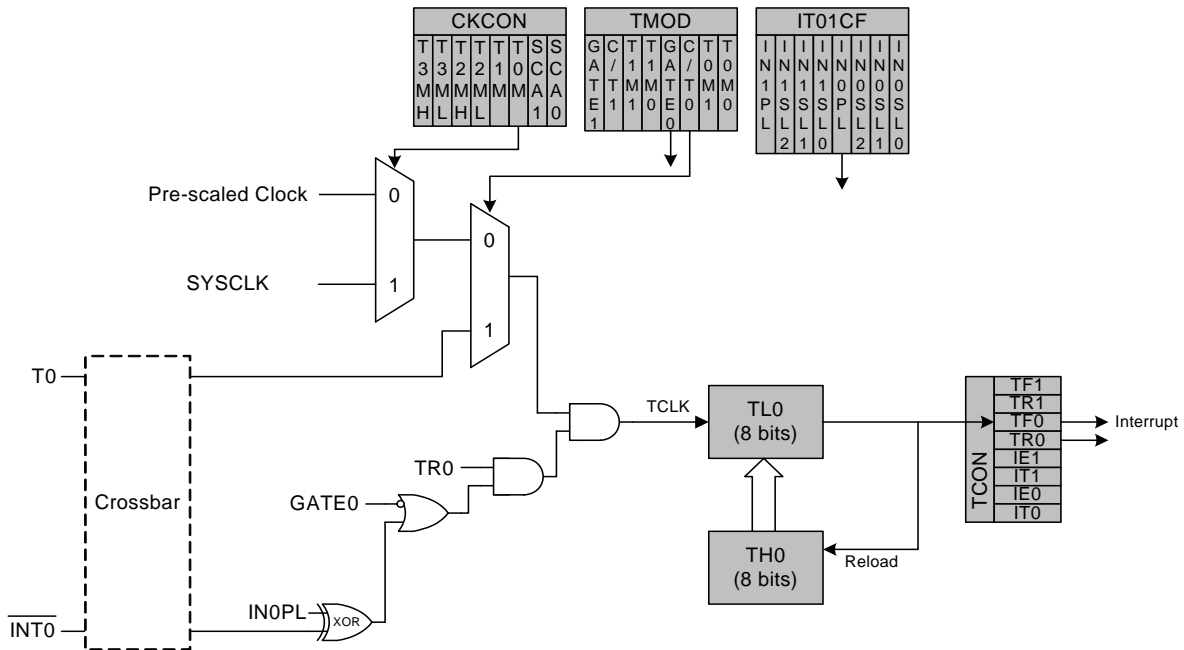

Figure 33.2. T0 Mode 2 Block Diagram

33.1.4. Mode 3: Two 8-bit Counter/Timers (Timer 0 Only)

In Mode 3, Timer 0 is configured as two separate 8-bit counter/timers held in TL0 and TH0. The counter/timer in TL0 is controlled using the Timer 0 control/status bits in TCON and TMOD: TR0, C/T0, GATE0 and TF0. TL0 can use either the system clock or an external input signal as its timebase. The TH0 register is restricted to a timer function sourced by the system clock or prescaled clock. TH0 is enabled using the Timer 1 run control bit TR1. TH0 sets the Timer 1 overflow flag TF1 on overflow and thus controls the Timer 1 interrupt.

Timer 1 is inactive in Mode 3. When Timer 0 is operating in Mode 3, Timer 1 can be operated in Modes 0, 1 or 2, but cannot be clocked by external signals nor set the TF1 flag and generate an interrupt. However, the Timer 1 overflow can be used to generate baud rates for the SMBus and/or UART, and/or initiate ADC conversions. While Timer 0 is operating in Mode 3, Timer 1 run control is handled through its mode settings. To run Timer 1 while Timer 0 is in Mode 3, set the Timer 1 Mode as 0, 1, or 2. To disable Timer 1, configure it for Mode 3.

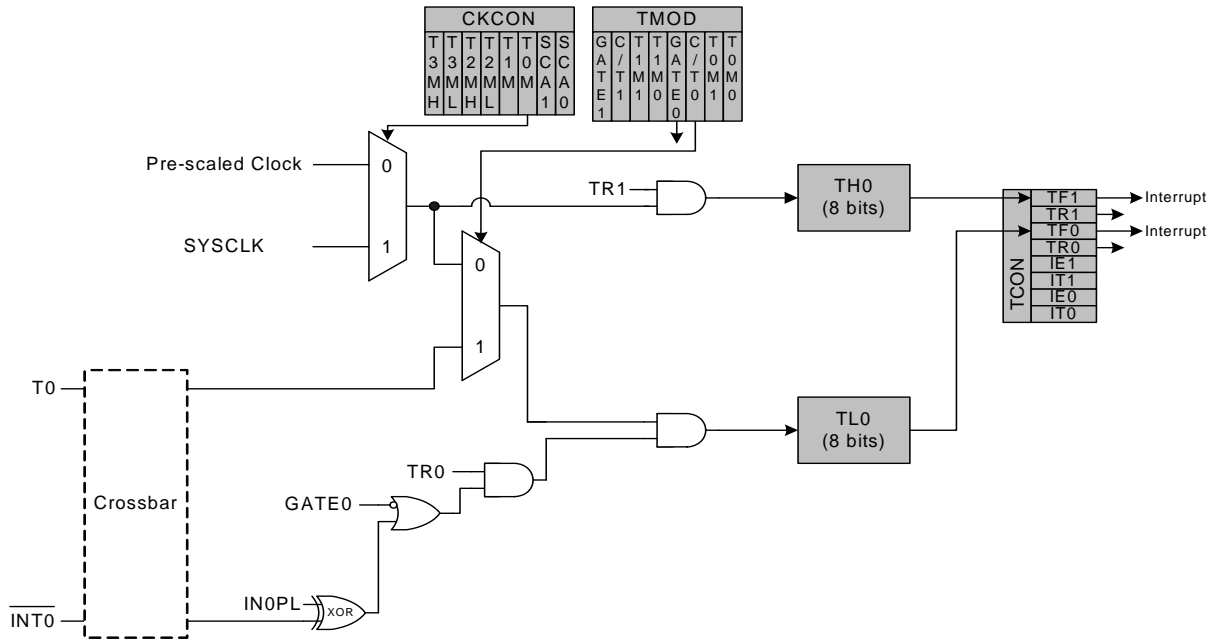

Figure 33.3. T0 Mode 3 Block Diagram

SFR Definition 33.2. TCON: Timer Control

Bit	7	6	5	4	3	2	1	0
Name	TF1	TR1	TF0	TR0	IE1	IT1	IE0	IT0
Type	R/W	R/W	R/W	R/W	R/W	R/W	R/W	R/W
Reset	0	0	0	0	0	0	0	0

SFR Page = All Pages; SFR Address = 0x88; Bit-Addressable

Bit	Name	Function
7	TF1	Timer 1 Overflow Flag. Set to 1 by hardware when Timer 1 overflows. This flag can be cleared by software but is automatically cleared when the CPU vectors to the Timer 1 interrupt service routine.
6	TR1	Timer 1 Run Control. Timer 1 is enabled by setting this bit to 1.
5	TF0	Timer 0 Overflow Flag. Set to 1 by hardware when Timer 0 overflows. This flag can be cleared by software but is automatically cleared when the CPU vectors to the Timer 0 interrupt service routine.
4	TR0	Timer 0 Run Control. Timer 0 is enabled by setting this bit to 1.
3	IE1	External Interrupt 1. This flag is set by hardware when an edge/level of type defined by IT1 is detected. It can be cleared by software but is automatically cleared when the CPU vectors to the External Interrupt 1 service routine in edge-triggered mode.
2	IT1	Interrupt 1 Type Select. This bit selects whether the configured $\overline{\text{INT1}}$ interrupt will be edge or level sensitive. $\overline{\text{INT1}}$ is configured active low or high by the IN1PL bit in the IT01CF register (see SFR Definition 17.7). 0: $\overline{\text{INT1}}$ is level triggered. 1: $\overline{\text{INT1}}$ is edge triggered.
1	IE0	External Interrupt 0. This flag is set by hardware when an edge/level of type defined by IT1 is detected. It can be cleared by software but is automatically cleared when the CPU vectors to the External Interrupt 0 service routine in edge-triggered mode.
0	IT0	Interrupt 0 Type Select. This bit selects whether the configured $\overline{\text{INT0}}$ interrupt will be edge or level sensitive. $\overline{\text{INT0}}$ is configured active low or high by the IN0PL bit in register IT01CF (see SFR Definition 17.7). 0: $\overline{\text{INT0}}$ is level triggered. 1: $\overline{\text{INT0}}$ is edge triggered.

Si102x/3x

SFR Definition 33.3. TMOD: Timer Mode

Bit	7	6	5	4	3	2	1	0
Name	GATE1	C/T1	T1M[1:0]		GATE0	C/T0	T0M[1:0]	
Type	R/W	R/W	R/W		R/W	R/W	R/W	
Reset	0	0	0	0	0	0	0	0

SFR Page = 0x0; SFR Address = 0x89

Bit	Name	Function
7	GATE1	Timer 1 Gate Control. 0: Timer 1 enabled when TR1 = 1 irrespective of $\overline{\text{INT1}}$ logic level. 1: Timer 1 enabled only when TR1 = 1 AND $\overline{\text{INT1}}$ is active as defined by bit IN1PL in register IT01CF (see SFR Definition 17.7).
6	C/T1	Counter/Timer 1 Select. 0: Timer: Timer 1 incremented by clock defined by T1M bit in register CKCON. 1: Counter: Timer 1 incremented by high-to-low transitions on external pin (T1).
5:4	T1M[1:0]	Timer 1 Mode Select. These bits select the Timer 1 operation mode. 00: Mode 0, 13-bit Counter/Timer 01: Mode 1, 16-bit Counter/Timer 10: Mode 2, 8-bit Counter/Timer with Auto-Reload 11: Mode 3, Timer 1 Inactive
3	GATE0	Timer 0 Gate Control. 0: Timer 0 enabled when TR0 = 1 irrespective of $\overline{\text{INT0}}$ logic level. 1: Timer 0 enabled only when TR0 = 1 AND $\overline{\text{INT0}}$ is active as defined by bit IN0PL in register IT01CF (see SFR Definition 17.7).
2	C/T0	Counter/Timer 0 Select. 0: Timer: Timer 0 incremented by clock defined by T0M bit in register CKCON. 1: Counter: Timer 0 incremented by high-to-low transitions on external pin (T0).
1:0	T0M[1:0]	Timer 0 Mode Select. These bits select the Timer 0 operation mode. 00: Mode 0, 13-bit Counter/Timer 01: Mode 1, 16-bit Counter/Timer 10: Mode 2, 8-bit Counter/Timer with Auto-Reload 11: Mode 3, Two 8-bit Counter/Timers

SFR Definition 33.4. TL0: Timer 0 Low Byte

Bit	7	6	5	4	3	2	1	0
Name	TL0[7:0]							
Type	R/W							
Reset	0	0	0	0	0	0	0	0

SFR Page = 0x0; SFR Address = 0x8A

Bit	Name	Function
7:0	TL0[7:0]	Timer 0 Low Byte. The TL0 register is the low byte of the 16-bit Timer 0.

SFR Definition 33.5. TL1: Timer 1 Low Byte

Bit	7	6	5	4	3	2	1	0
Name	TL1[7:0]							
Type	R/W							
Reset	0	0	0	0	0	0	0	0

SFR Page = 0x0; SFR Address = 0x8B

Bit	Name	Function
7:0	TL1[7:0]	Timer 1 Low Byte. The TL1 register is the low byte of the 16-bit Timer 1.

Si102x/3x

SFR Definition 33.6. TH0: Timer 0 High Byte

Bit	7	6	5	4	3	2	1	0
Name	TH0[7:0]							
Type	R/W							
Reset	0	0	0	0	0	0	0	0

SFR Page = 0x0; SFR Address = 0x8C

Bit	Name	Function
7:0	TH0[7:0]	Timer 0 High Byte. The TH0 register is the high byte of the 16-bit Timer 0.

SFR Definition 33.7. TH1: Timer 1 High Byte

Bit	7	6	5	4	3	2	1	0
Name	TH1[7:0]							
Type	R/W							
Reset	0	0	0	0	0	0	0	0

SFR Page = 0x0; SFR Address = 0x8D

Bit	Name	Function
7:0	TH1[7:0]	Timer 1 High Byte. The TH1 register is the high byte of the 16-bit Timer 1.

33.2. Timer 2

Timer 2 is a 16-bit timer formed by two 8-bit SFRs: TMR2L (low byte) and TMR2H (high byte). Timer 2 may operate in 16-bit auto-reload mode or (split) 8-bit auto-reload mode. The T2SPLIT bit (TMR2CN.3) defines the Timer 2 operation mode. Timer 2 can also be used in Capture Mode to measure the SmarTclock or the Comparator 0 period with respect to another oscillator. The ability to measure the Comparator 0 period with respect to the system clock makes using Touch Sense Switches very easy.

Timer 2 may be clocked by the system clock, the system clock divided by 12, SmarTclock divided by 8, or Comparator 0 output. Note that the SmarTclock divided by 8 and Comparator 0 output is synchronized with the system clock.

33.2.1. 16-bit Timer with Auto-Reload

When T2SPLIT (TMR2CN.3) is zero, Timer 2 operates as a 16-bit timer with auto-reload. Timer 2 can be clocked by SYSCLK, SYSCLK divided by 12, SmarTclock divided by 8, or Comparator 0 output. As the 16-bit timer register increments and overflows from 0xFFFF to 0x0000, the 16-bit value in the Timer 2 reload registers (TMR2RLH and TMR2RLL) is loaded into the Timer 2 register as shown in Figure 33.4, and the Timer 2 High Byte Overflow Flag (TMR2CN.7) is set. If Timer 2 interrupts are enabled (if IE.5 is set), an interrupt will be generated on each Timer 2 overflow. Additionally, if Timer 2 interrupts are enabled and the TF2LEN bit is set (TMR2CN.5), an interrupt will be generated each time the lower 8 bits (TMR2L) overflow from 0xFF to 0x00.

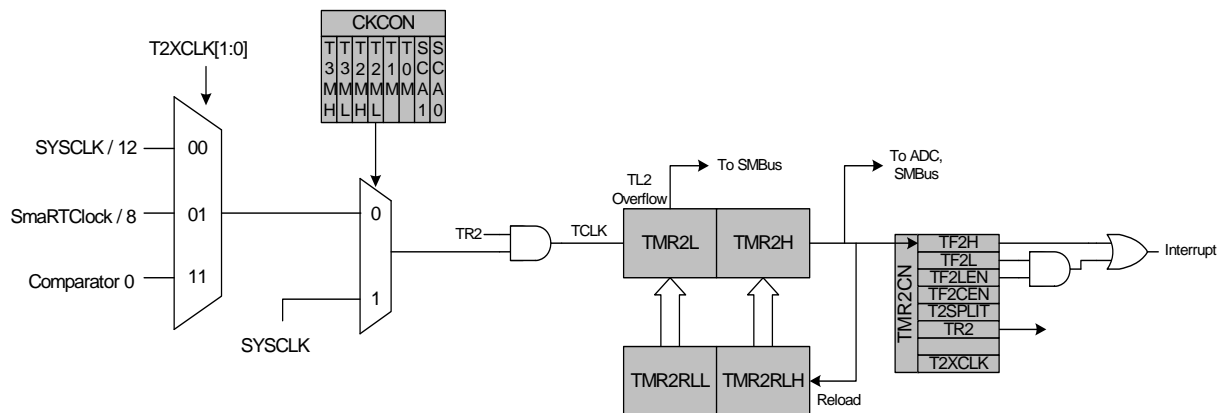

Figure 33.4. Timer 2 16-Bit Mode Block Diagram

Si102x/3x

33.2.2. 8-bit Timers with Auto-Reload

When T2SPLIT is set, Timer 2 operates as two 8-bit timers (TMR2H and TMR2L). Both 8-bit timers operate in auto-reload mode as shown in Figure 33.5. TMR2RLL holds the reload value for TMR2L; TMR2RLH holds the reload value for TMR2H. The TR2 bit in TMR2CN handles the run control for TMR2H. TMR2L is always running when configured for 8-bit Mode.

Each 8-bit timer may be configured to use SYSCLK, SYSCLK divided by 12, SmarTClock divided by 8 or Comparator 0 output. The Timer 2 Clock Select bits (T2MH and T2ML in CKCON) select either SYSCLK or the clock defined by the Timer 2 External Clock Select bits (T2XCLK[1:0] in TMR2CN), as follows:

T2MH	T2XCLK[1:0]	TMR2H Clock Source
0	00	SYSCLK / 12
0	01	SmaRTClock / 8
0	10	Reserved
0	11	Comparator 0
1	X	SYSCLK

T2ML	T2XCLK[1:0]	TMR2L Clock Source
0	00	SYSCLK / 12
0	01	SmaRTClock / 8
0	10	Reserved
0	11	Comparator 0
1	X	SYSCLK

The TF2H bit is set when TMR2H overflows from 0xFF to 0x00; the TF2L bit is set when TMR2L overflows from 0xFF to 0x00. When Timer 2 interrupts are enabled (IE.5), an interrupt is generated each time TMR2H overflows. If Timer 2 interrupts are enabled and TF2LEN (TMR2CN.5) is set, an interrupt is generated each time either TMR2L or TMR2H overflows. When TF2LEN is enabled, software must check the TF2H and TF2L flags to determine the source of the Timer 2 interrupt. The TF2H and TF2L interrupt flags are not cleared by hardware and must be manually cleared by software.

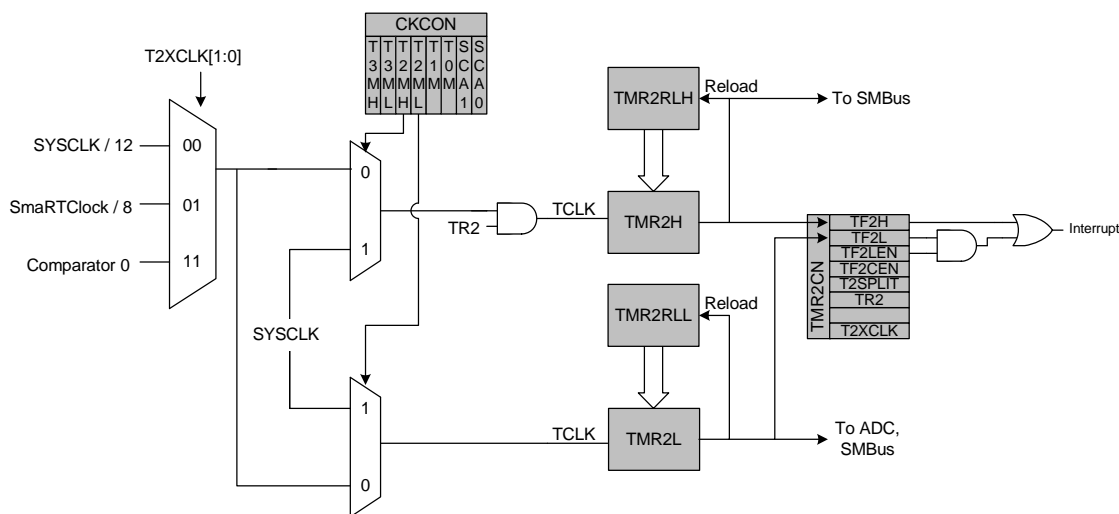

Figure 33.5. Timer 2 8-Bit Mode Block Diagram

33.2.3. Comparator 0/SmaRTClock Capture Mode

The Capture Mode in Timer 2 allows either Comparator 0 or the SmarTClock period to be measured against the system clock or the system clock divided by 12. Comparator 0 and the SmarTClock period can also be compared against each other. Timer 2 Capture Mode is enabled by setting TF2CEN to 1. Timer 2 should be in 16-bit auto-reload mode when using Capture Mode.

When Capture Mode is enabled, a capture event will be generated either every Comparator 0 rising edge or every 8 SmaRTClock clock cycles, depending on the T2XCLK1 setting. When the capture event occurs, the contents of Timer 2 (TMR2H:TMR2L) are loaded into the Timer 2 reload registers (TMR2RLL:TMR2RLH) and the TF2H flag is set (triggering an interrupt if Timer 2 interrupts are enabled). By recording the difference between two successive timer capture values, the Comparator 0 or SmaRT-Clock period can be determined with respect to the Timer 2 clock. The Timer 2 clock should be much faster than the capture clock to achieve an accurate reading.

For example, if T2ML = 1b, T2XCLK1 = 0b, and TF2CEN = 1b, Timer 2 will clock every SYSCLK and capture every SmaRTClock clock divided by 8. If the SYSCLK is 24.5 MHz and the difference between two successive captures is 5984, then the SmaRTClock clock is as follows:

$$24.5 \text{ MHz} / (5984 / 8) = 0.032754 \text{ MHz or } 32.754 \text{ kHz.}$$

This mode allows software to determine the exact SmaRTClock frequency in self-oscillate mode and the time between consecutive Comparator 0 rising edges, which is useful for detecting changes in the capacitance of a Touch Sense Switch.

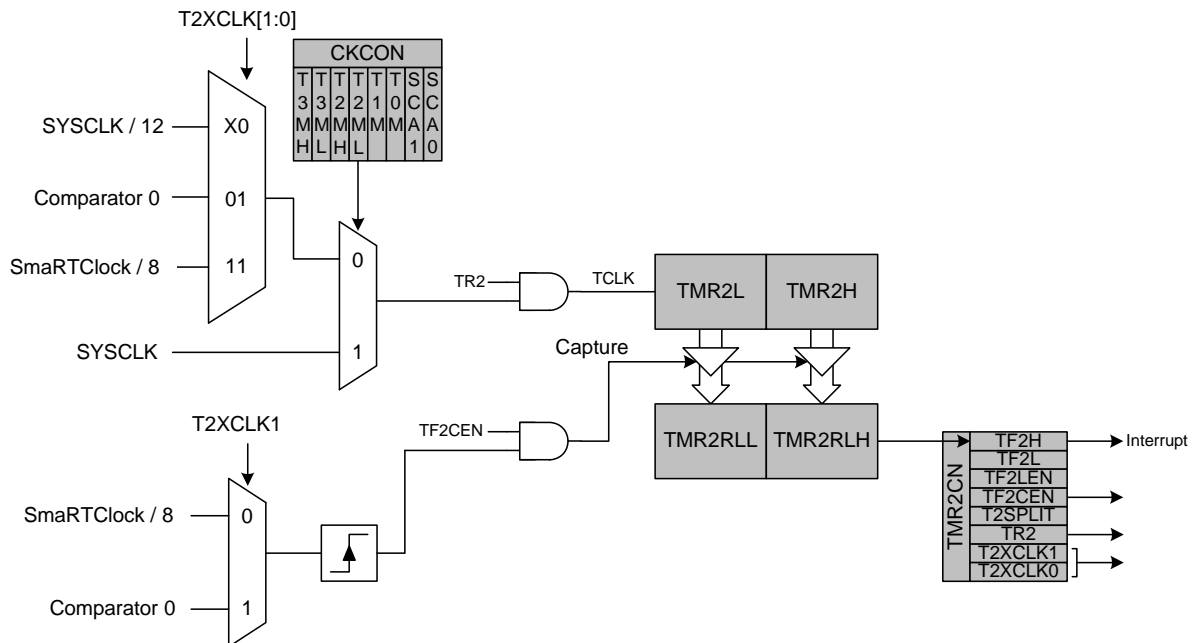

Figure 33.6. Timer 2 Capture Mode Block Diagram

SFR Definition 33.8. TMR2CN: Timer 2 Control

Bit	7	6	5	4	3	2	1	0
Name	TF2H	TF2L	TF2LEN	TF2CEN	T2SPLIT	TR2	T2XCLK[1:0]	
Type	R/W	R/W	R/W	R/W	R/W	R/W	R/W	
Reset	0	0	0	0	0	0	0	0

SFR Page = All Pages; SFR Address = 0xC8; Bit-Addressable

Bit	Name	Function
7	TF2H	<p>Timer 2 High Byte Overflow Flag.</p> <p>Set by hardware when the Timer 2 high byte overflows from 0xFF to 0x00. In 16-bit mode, this will occur when Timer 2 overflows from 0xFFFF to 0x0000. When the Timer 2 interrupt is enabled, setting this bit causes the CPU to vector to the Timer 2 interrupt service routine. This bit is not automatically cleared by hardware.</p>
6	TF2L	<p>Timer 2 Low Byte Overflow Flag.</p> <p>Set by hardware when the Timer 2 low byte overflows from 0xFF to 0x00. TF2L will be set when the low byte overflows regardless of the Timer 2 mode. This bit is not automatically cleared by hardware.</p>
5	TF2LEN	<p>Timer 2 Low Byte Interrupt Enable.</p> <p>When set to 1, this bit enables Timer 2 Low Byte interrupts. If Timer 2 interrupts are also enabled, an interrupt will be generated when the low byte of Timer 2 overflows.</p>
4	TF2CEN	<p>Timer 2 Capture Enable.</p> <p>When set to 1, this bit enables Timer 2 Capture Mode.</p>
3	T2SPLIT	<p>Timer 2 Split Mode Enable.</p> <p>When set to 1, Timer 2 operates as two 8-bit timers with auto-reload. Otherwise, Timer 2 operates in 16-bit auto-reload mode.</p>
2	TR2	<p>Timer 2 Run Control.</p> <p>Timer 2 is enabled by setting this bit to 1. In 8-bit mode, this bit enables/disables TMR2H only; TMR2L is always enabled in split mode.</p>
1:0	T2XCLK[1:0]	<p>Timer 2 External Clock Select.</p> <p>This bit selects the “external” and “capture trigger” clock sources for Timer 2. If Timer 2 is in 8-bit mode, this bit selects the “external” clock source for both timer bytes. Timer 2 Clock Select bits (T2MH and T2ML in register CKCON) may still be used to select between the “external” clock and the system clock for either timer. Note: External clock sources are synchronized with the system clock.</p> <p>00: External Clock is SYSCLK/12. Capture trigger is SmarTClock/8. 01: External Clock is Comparator 0. Capture trigger is SmarTClock/8. 10: External Clock is SYSCLK/12. Capture trigger is Comparator 0. 11: External Clock is SmarTClock/8. Capture trigger is Comparator 0.</p>

SFR Definition 33.9. TMR2RLL: Timer 2 Reload Register Low Byte

Bit	7	6	5	4	3	2	1	0
Name	TMR2RLL[7:0]							
Type	R/W							
Reset	0	0	0	0	0	0	0	0

SFR Page = 0x0; SFR Address = 0xCA

Bit	Name	Function
7:0	TMR2RLL[7:0]	Timer 2 Reload Register Low Byte. TMR2RLL holds the low byte of the reload value for Timer 2.

SFR Definition 33.10. TMR2RLH: Timer 2 Reload Register High Byte

Bit	7	6	5	4	3	2	1	0
Name	TMR2RLH[7:0]							
Type	R/W							
Reset	0	0	0	0	0	0	0	0

SFR Page = 0x0; SFR Address = 0xCB

Bit	Name	Function
7:0	TMR2RLH[7:0]	Timer 2 Reload Register High Byte. TMR2RLH holds the high byte of the reload value for Timer 2.

Si102x/3x

SFR Definition 33.11. TMR2L: Timer 2 Low Byte

Bit	7	6	5	4	3	2	1	0
Name	TMR2L[7:0]							
Type	R/W							
Reset	0	0	0	0	0	0	0	0

SFR Page = 0x0; SFR Address = 0xCC

Bit	Name	Function
7:0	TMR2L[7:0]	Timer 2 Low Byte. In 16-bit mode, the TMR2L register contains the low byte of the 16-bit Timer 2. In 8-bit mode, TMR2L contains the 8-bit low byte timer value.

SFR Definition 33.12. TMR2H Timer 2 High Byte

Bit	7	6	5	4	3	2	1	0
Name	TMR2H[7:0]							
Type	R/W							
Reset	0	0	0	0	0	0	0	0

SFR Page = 0x0; SFR Address = 0xCD

Bit	Name	Function
7:0	TMR2H[7:0]	Timer 2 High Byte. In 16-bit mode, the TMR2H register contains the high byte of the 16-bit Timer 2. In 8-bit mode, TMR2H contains the 8-bit high byte timer value.

33.3. Timer 3

Timer 3 is a 16-bit timer formed by two 8-bit SFRs: TMR3L (low byte) and TMR3H (high byte). Timer 3 may operate in 16-bit auto-reload mode or (split) 8-bit auto-reload mode. The T3SPLIT bit (TMR2CN.3) defines the Timer 3 operation mode. Timer 3 can also be used in Capture Mode to measure the external oscillator source or the SmarTClock oscillator period with respect to another oscillator.

Timer 3 may be clocked by the system clock, the system clock divided by 12, external oscillator source divided by 8, or the SmarTClock oscillator. The external oscillator source divided by 8 and SmarTClock oscillator is synchronized with the system clock.

33.3.1. 16-bit Timer with Auto-Reload

When T3SPLIT (TMR3CN.3) is zero, Timer 3 operates as a 16-bit timer with auto-reload. Timer 3 can be clocked by SYSCLK, SYSCLK divided by 12, external oscillator clock source divided by 8, or SmarTClock oscillator. As the 16-bit timer register increments and overflows from 0xFFFF to 0x0000, the 16-bit value in the Timer 3 reload registers (TMR3RLH and TMR3RLL) is loaded into the Timer 3 register as shown in Figure 33.7, and the Timer 3 High Byte Overflow Flag (TMR3CN.7) is set. If Timer 3 interrupts are enabled (if EIE1.7 is set), an interrupt will be generated on each Timer 3 overflow. Additionally, if Timer 3 interrupts are enabled and the TF3LEN bit is set (TMR3CN.5), an interrupt will be generated each time the lower 8 bits (TMR3L) overflow from 0xFF to 0x00.

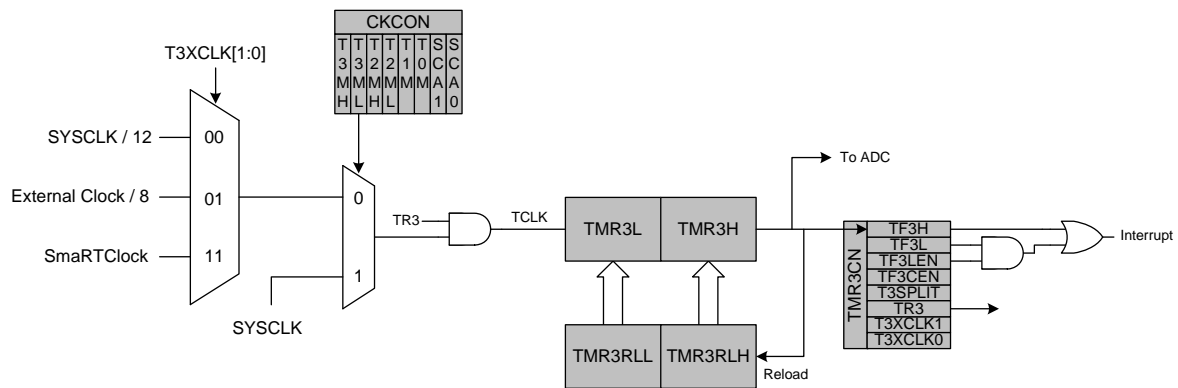

Figure 33.7. Timer 3 16-Bit Mode Block Diagram

Si102x/3x

33.3.2. 8-Bit Timers with Auto-Reload

When T3SPLIT is set, Timer 3 operates as two 8-bit timers (TMR3H and TMR3L). Both 8-bit timers operate in auto-reload mode as shown in Figure 33.8. TMR3RLL holds the reload value for TMR3L; TMR3RLH holds the reload value for TMR3H. The TR3 bit in TMR3CN handles the run control for TMR3H. TMR3L is always running when configured for 8-bit Mode.

Each 8-bit timer may be configured to use SYSCLK, SYSCLK divided by 12, the external oscillator clock source divided by 8, or the SmarTClock. The Timer 3 Clock Select bits (T3MH and T3ML in CKCON) select either SYSCLK or the clock defined by the Timer 3 External Clock Select bits (T3XCLK[1:0] in TMR3CN), as follows:

T3MH	T3XCLK[1:0]	TMR3H Clock Source
0	00	SYSCLK / 12
0	01	SmaRTClock
0	10	Reserved
0	11	External Clock / 8
1	X	SYSCLK

T3ML	T3XCLK[1:0]	TMR3L Clock Source
0	00	SYSCLK / 12
0	01	SmaRTClock
0	10	Reserved
0	11	External Clock / 8
1	X	SYSCLK

The TF3H bit is set when TMR3H overflows from 0xFF to 0x00; the TF3L bit is set when TMR3L overflows from 0xFF to 0x00. When Timer 3 interrupts are enabled, an interrupt is generated each time TMR3H overflows. If Timer 3 interrupts are enabled and TF3LEN (TMR3CN.5) is set, an interrupt is generated each time either TMR3L or TMR3H overflows. When TF3LEN is enabled, software must check the TF3H and TF3L flags to determine the source of the Timer 3 interrupt. The TF3H and TF3L interrupt flags are not cleared by hardware and must be manually cleared by software.

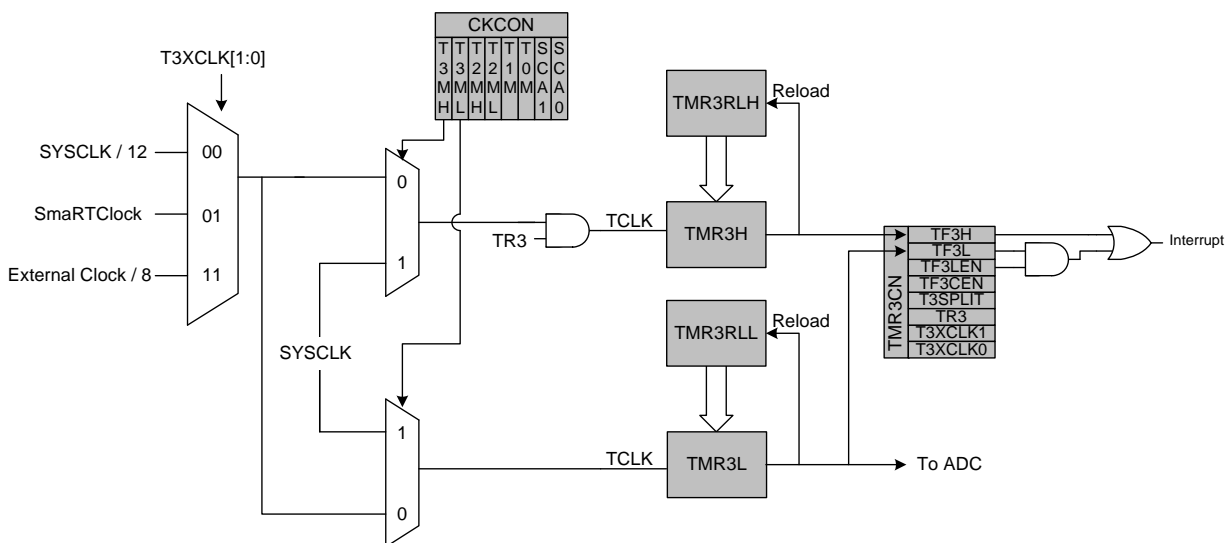

Figure 33.8. Timer 3 8-Bit Mode Block Diagram

33.3.3. SmarTClock/External Oscillator Capture Mode

The Capture Mode in Timer 3 allows either SmarTClock or the external oscillator period to be measured against the system clock or the system clock divided by 12. SmarTClock and the external oscillator period can also be compared against each other.

Setting TF3CEN to 1 enables the SmartClock/External Oscillator Capture Mode for Timer 3. In this mode, T3SPLIT should be set to 0, as the full 16-bit timer is used.

When Capture Mode is enabled, a capture event will be generated either every SmartClock rising edge or every 8 external clock cycles, depending on the T3XCLK1 setting. When the capture event occurs, the contents of Timer 3 (TMR3H:TMR3L) are loaded into the Timer 3 reload registers (TMR3RLH:TMR3RLL) and the TF3H flag is set (triggering an interrupt if Timer 3 interrupts are enabled). By recording the difference between two successive timer capture values, the SmartClock or external clock period can be determined with respect to the Timer 3 clock. The Timer 3 clock should be much faster than the capture clock to achieve an accurate reading.

For example, if T3ML = 1b, T3XCLK1 = 0b, and TF3CEN = 1b, Timer 3 will clock every SYSCLK and capture every SmartClock rising edge. If SYSCLK is 24.5 MHz and the difference between two successive captures is 350 counts, then the SmartClock period is as follows:

$$350 \times (1 / 24.5 \text{ MHz}) = 14.2 \mu\text{s}.$$

This mode allows software to determine the exact frequency of the external oscillator in C and RC mode or the time between consecutive SmartClock rising edges, which is useful for determining the SmartClock frequency.

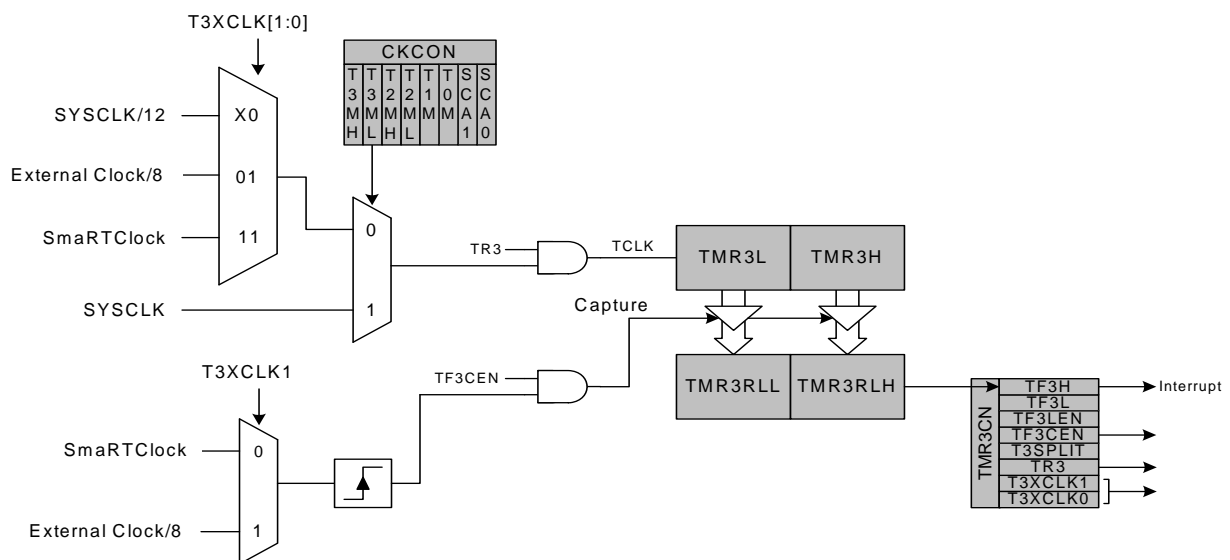

Figure 33.9. Timer 3 Capture Mode Block Diagram

SFR Definition 33.13. TMR3CN: Timer 3 Control

Bit	7	6	5	4	3	2	1	0
Name	TF3H	TF3L	TF3LEN	TF3CEN	T3SPLIT	TR3	T3XCLK[1:0]	
Type	R/W	R/W	R/W	R/W	R/W	R/W	R/W	
Reset	0	0	0	0	0	0	0	0

SFR Page = 0x0; SFR Address = 0x91

Bit	Name	Function
7	TF3H	<p>Timer 3 High Byte Overflow Flag.</p> <p>Set by hardware when the Timer 3 high byte overflows from 0xFF to 0x00. In 16 bit mode, this will occur when Timer 3 overflows from 0xFFFF to 0x0000. When the Timer 3 interrupt is enabled, setting this bit causes the CPU to vector to the Timer 3 interrupt service routine. This bit is not automatically cleared by hardware.</p>
6	TF3L	<p>Timer 3 Low Byte Overflow Flag.</p> <p>Set by hardware when the Timer 3 low byte overflows from 0xFF to 0x00. TF3L will be set when the low byte overflows regardless of the Timer 3 mode. This bit is not automatically cleared by hardware.</p>
5	TF3LEN	<p>Timer 3 Low Byte Interrupt Enable.</p> <p>When set to 1, this bit enables Timer 3 Low Byte interrupts. If Timer 3 interrupts are also enabled, an interrupt will be generated when the low byte of Timer 3 overflows.</p>
4	TF3CEN	<p>Timer 3 SmarTclock/External Oscillator Capture Enable.</p> <p>When set to 1, this bit enables Timer 3 Capture Mode.</p>
3	T3SPLIT	<p>Timer 3 Split Mode Enable.</p> <p>When this bit is set, Timer 3 operates as two 8-bit timers with auto-reload. 0: Timer 3 operates in 16-bit auto-reload mode. 1: Timer 3 operates as two 8-bit auto-reload timers.</p>
2	TR3	<p>Timer 3 Run Control.</p> <p>Timer 3 is enabled by setting this bit to 1. In 8-bit mode, this bit enables/disables TMR3H only; TMR3L is always enabled in split mode.</p>
1:0	T3XCLK[1:0]	<p>Timer 3 External Clock Select.</p> <p>This bit selects the “external” and “capture trigger” clock sources for Timer 3. If Timer 3 is in 8-bit mode, this bit selects the “external” clock source for both timer bytes. Timer 3 Clock Select bits (T3MH and T3ML in register CKCON) may still be used to select between the “external” clock and the system clock for either timer. Note: External clock sources are synchronized with the system clock. 00: External Clock is SYSCLK /12. Capture trigger is SmarTclock. 01: External Clock is External Oscillator/8. Capture trigger is SmarTclock. 10: External Clock is SYSCLK/12. Capture trigger is External Oscillator/8. 11: External Clock is SmarTclock. Capture trigger is External Oscillator/8.</p>

SFR Definition 33.14. TMR3RLL: Timer 3 Reload Register Low Byte

Bit	7	6	5	4	3	2	1	0
Name	TMR3RLL[7:0]							
Type	R/W							
Reset	0	0	0	0	0	0	0	0

SFR Page = 0x0; SFR Address = 0x92

Bit	Name	Function
7:0	TMR3RLL[7:0]	Timer 3 Reload Register Low Byte. TMR3RLL holds the low byte of the reload value for Timer 3.

SFR Definition 33.15. TMR3RLH: Timer 3 Reload Register High Byte

Bit	7	6	5	4	3	2	1	0
Name	TMR3RLH[7:0]							
Type	R/W							
Reset	0	0	0	0	0	0	0	0

SFR Page = 0x0; SFR Address = 0x93

Bit	Name	Function
7:0	TMR3RLH[7:0]	Timer 3 Reload Register High Byte. TMR3RLH holds the high byte of the reload value for Timer 3.

Si102x/3x

SFR Definition 33.16. TMR3L: Timer 3 Low Byte

Bit	7	6	5	4	3	2	1	0
Name	TMR3L[7:0]							
Type	R/W							
Reset	0	0	0	0	0	0	0	0

SFR Page = 0x0; SFR Address = 0x94

Bit	Name	Function
7:0	TMR3L[7:0]	Timer 3 Low Byte. In 16-bit mode, the TMR3L register contains the low byte of the 16-bit Timer 3. In 8-bit mode, TMR3L contains the 8-bit low byte timer value.

SFR Definition 33.17. TMR3H Timer 3 High Byte

Bit	7	6	5	4	3	2	1	0
Name	TMR3H[7:0]							
Type	R/W							
Reset	0	0	0	0	0	0	0	0

SFR Page = 0x0; SFR Address = 0x95

Bit	Name	Function
7:0	TMR3H[7:0]	Timer 3 High Byte. In 16-bit mode, the TMR3H register contains the high byte of the 16-bit Timer 3. In 8-bit mode, TMR3H contains the 8-bit high byte timer value.

34. Programmable Counter Array

The Programmable Counter Array (PCA0) provides enhanced timer functionality while requiring less CPU intervention than the standard 8051 counter/timers. The PCA consists of a dedicated 16-bit counter/timer and six 16-bit capture/compare modules. Each capture/compare module has its own associated I/O line (CEXn) which is routed through the Crossbar to Port I/O when enabled. The counter/timer is driven by a programmable timebase that can select between seven sources: system clock, system clock divided by four, system clock divided by twelve, the external oscillator clock source divided by 8, SmaRTClock divided by 8, Timer 0 overflows, or an external clock signal on the ECI input pin. Each capture/compare module may be configured to operate independently in one of six modes: Edge-Triggered Capture, Software Timer, High-Speed Output, Frequency Output, 8 to 11-Bit PWM, or 16-Bit PWM (each mode is described in Section “34.3. Capture/Compare Modules” on page 516). The external oscillator clock option is ideal for real-time clock (RTC) functionality, allowing the PCA to be clocked by a precision external oscillator while the internal oscillator drives the system clock. The PCA is configured and controlled through the system controller's Special Function Registers. The PCA block diagram is shown in Figure 34.1

Important Note: The PCA Module 5 may be used as a watchdog timer (WDT), and is enabled in this mode following a system reset. **Access to certain PCA registers is restricted while WDT mode is enabled.** See Section 34.4 for details.

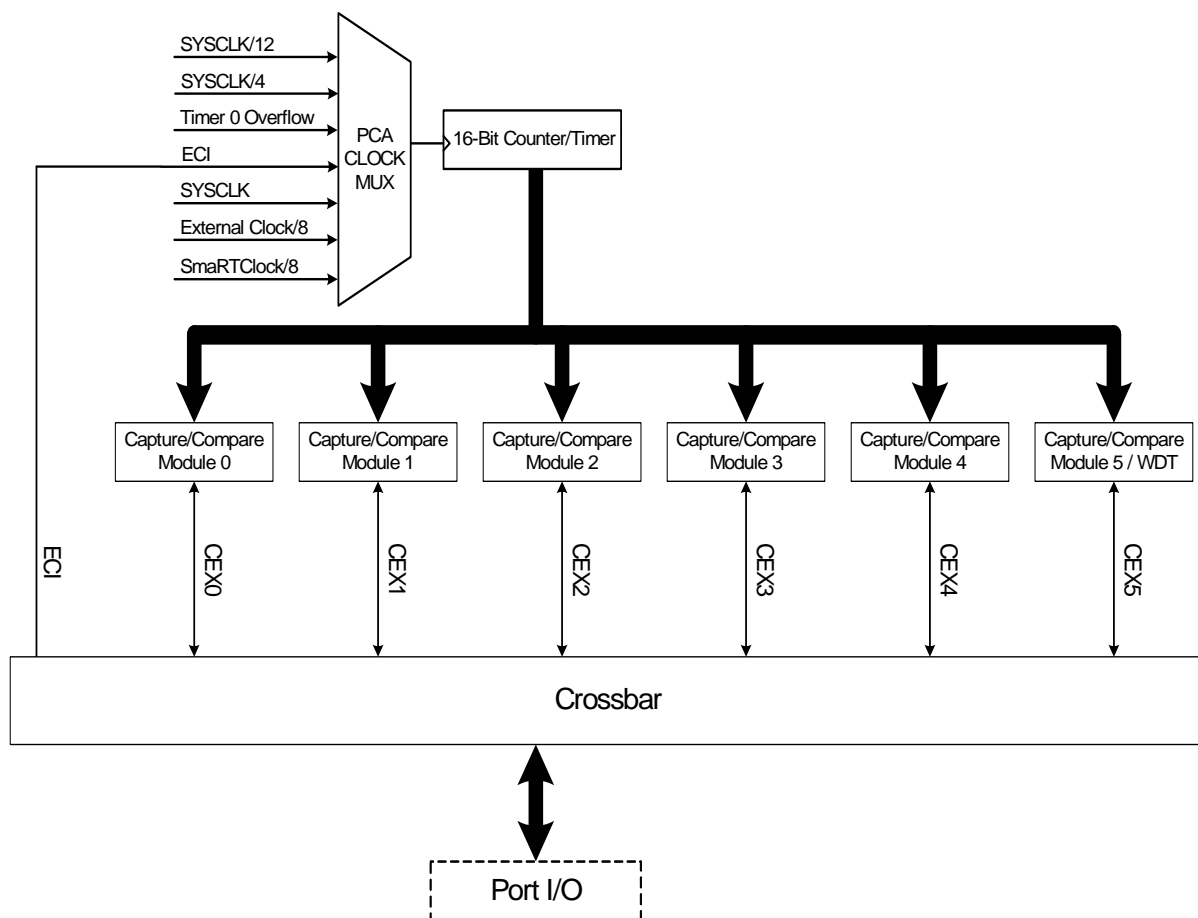

Figure 34.1. PCA Block Diagram

34.1. PCA Counter/Timer

The 16-bit PCA counter/timer consists of two 8-bit SFRs: PCA0L and PCA0H. PCA0H is the high byte (MSB) of the 16-bit counter/timer and PCA0L is the low byte (LSB). Reading PCA0L automatically latches the value of PCA0H into a “snapshot” register; the following PCA0H read accesses this “snapshot” register. **Reading the PCA0L Register first guarantees an accurate reading of the entire 16-bit PCA0 counter.** Reading PCA0H or PCA0L does not disturb the counter operation. The CPS2–CPS0 bits in the PCA0MD register select the timebase for the counter/timer as shown in Table 34.1.

When the counter/timer overflows from 0xFFFF to 0x0000, the Counter Overflow Flag (CF) in PCA0MD is set to logic 1 and an interrupt request is generated if CF interrupts are enabled. Setting the ECF bit in PCA0MD to logic 1 enables the CF flag to generate an interrupt request. The CF bit is not automatically cleared by hardware when the CPU vectors to the interrupt service routine, and must be cleared by software. Clearing the CIDL bit in the PCA0MD register allows the PCA to continue normal operation while the CPU is in Idle mode.

Table 34.1. PCA Timebase Input Options

CPS2	CPS1	CPS0	Timebase
0	0	0	System clock divided by 12
0	0	1	System clock divided by 4
0	1	0	Timer 0 overflow
0	1	1	High-to-low transitions on ECI (max rate = system clock divided by 4)
1	0	0	System clock
1	0	1	External oscillator source divided by 8 ¹
1	1	0	SmaRTClock oscillator source divided by 8 ²
1	1	1	Reserved

Notes:

1. External oscillator source divided by 8 is synchronized with the system clock.
2. SmaRTClock oscillator source divided by 8 is synchronized with the system clock.

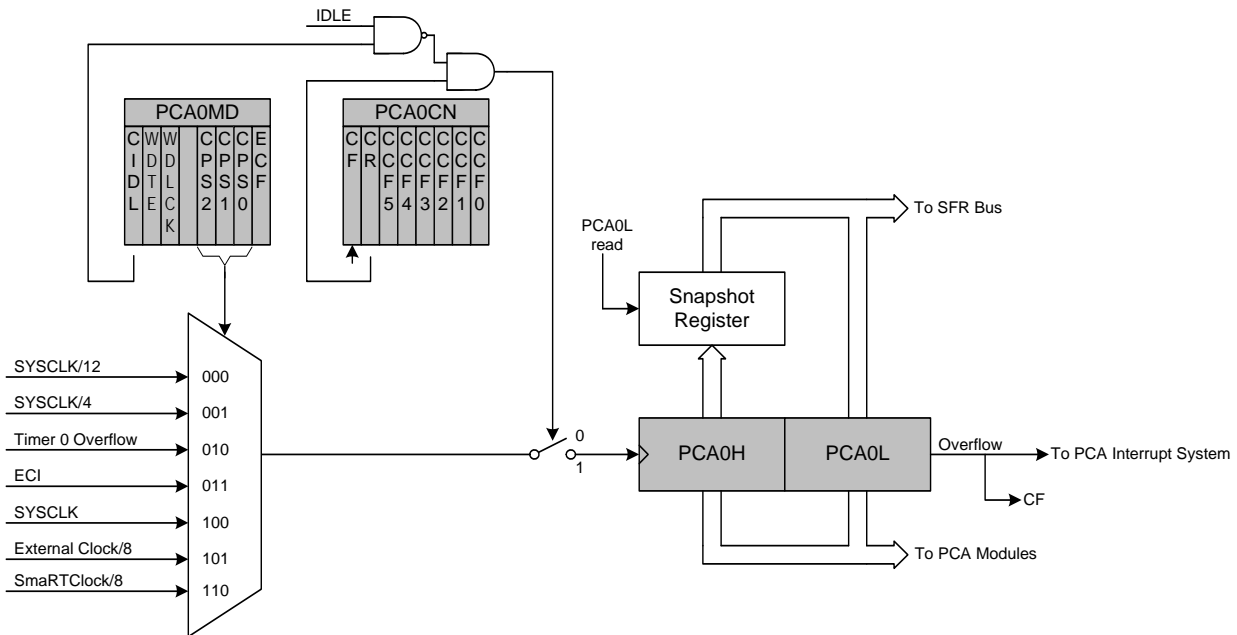

Figure 34.2. PCA Counter/Timer Block Diagram

34.2. PCA0 Interrupt Sources

Figure 34.3 shows a diagram of the PCA interrupt tree. There are eight independent event flags that can be used to generate a PCA0 interrupt. They are: the main PCA counter overflow flag (CF), which is set upon a 16-bit overflow of the PCA0 counter, an intermediate overflow flag (COVF), which can be set on an overflow from the 8th, 9th, 10th, or 11th bit of the PCA0 counter, and the individual flags for each PCA channel (CCF0, CCF1, CCF2, CCF3, CCF4, and CCF5), which are set according to the operation mode of that module. These event flags are always set when the trigger condition occurs. Each of these flags can be individually selected to generate a PCA0 interrupt, using the corresponding interrupt enable flag (ECF for CF, ECOV for COVF, and ECCFn for each CCFn). PCA0 interrupts must be globally enabled before any individual interrupt sources are recognized by the processor. PCA0 interrupts are globally enabled by setting the EA bit and the EPCA0 bit to logic 1.

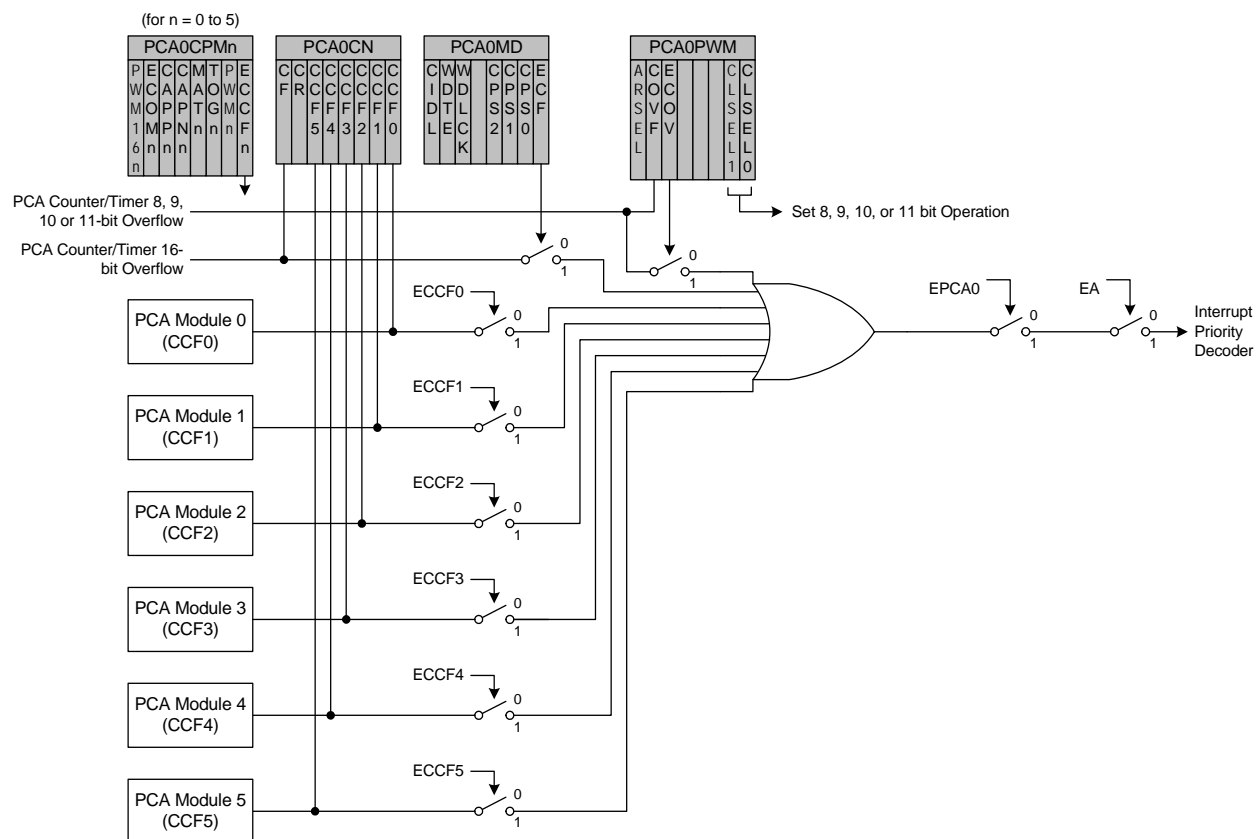

Figure 34.3. PCA Interrupt Block Diagram

34.3. Capture/Compare Modules

Each module can be configured to operate independently in one of six operation modes: edge-triggered capture, software timer, high speed output, frequency output, 8 to 11-bit pulse width modulator, or 16-bit pulse width modulator. Each module has Special Function Registers (SFRs) associated with it in the CIP-51 system controller. These registers are used to exchange data with a module and configure the module's mode of operation. Table 34.2 summarizes the bit settings in the PCA0CPMn and PCA0PWM registers used to select the PCA capture/compare module's operating mode. Note that all modules set to use 8, 9, 10, or 11-bit PWM mode must use the same cycle length (8-11 bits). Setting the ECCFn bit in a PCA0CPMn register enables the module's CCFn interrupt.

Table 34.2. PCA0CPM and PCA0PWM Bit Settings for PCA Capture/Compare Modules

Operational Mode	PCA0CPMn								PCA0PWM				
	7	6	5	4	3	2	1	0	7	6	5	4-2	1-0
Capture triggered by positive edge on CEXn	X	X	1	0	0	0	0	A	0	X	B	XXX	XX
Capture triggered by negative edge on CEXn	X	X	0	1	0	0	0	A	0	X	B	XXX	XX
Capture triggered by any transition on CEXn	X	X	1	1	0	0	0	A	0	X	B	XXX	XX

Table 34.2. PCA0CPM and PCA0PWM Bit Settings for PCA Capture/Compare Modules

Operational Mode	PCA0CPMn								PCA0PWM				
	X	C	0	0	1	0	0	A	0	X	B	XXX	XX
Software Timer	X	C	0	0	1	0	0	A	0	X	B	XXX	XX
High Speed Output	X	C	0	0	1	1	0	A	0	X	B	XXX	XX
Frequency Output	X	C	0	0	0	1	1	A	0	X	B	XXX	XX
8-Bit Pulse Width Modulator (Note 7)	0	C	0	0	E	0	1	A	0	X	B	XXX	00
9-Bit Pulse Width Modulator (Note 7)	0	C	0	0	E	0	1	A	D	X	B	XXX	01
10-Bit Pulse Width Modulator (Note 7)	0	C	0	0	E	0	1	A	D	X	B	XXX	10
11-Bit Pulse Width Modulator (Note 7)	0	C	0	0	E	0	1	A	D	X	B	XXX	11
16-Bit Pulse Width Modulator	1	C	0	0	E	0	1	A	0	X	B	XXX	XX

Notes:

1. X = Don't Care (no functional difference for individual module if 1 or 0).
2. A = Enable interrupts for this module (PCA interrupt triggered on CCFn set to 1).
3. B = Enable 8th, 9th, 10th or 11th bit overflow interrupt (Depends on setting of CLSEL[1:0]).
4. C = When set to 0, the digital comparator is off. For high speed and frequency output modes, the associated pin will not toggle. In any of the PWM modes, this generates a 0% duty cycle (output = 0).
5. D = Selects whether the Capture/Compare register (0) or the Auto-Reload register (1) for the associated channel is accessed via addresses PCA0CPHn and PCA0CPLn.
6. E = When set, a match event will cause the CCFn flag for the associated channel to be set.
7. All modules set to 8, 9, 10 or 11-bit PWM mode use the same cycle length setting.

34.3.1. Edge-triggered Capture Mode

In this mode, a valid transition on the CEXn pin causes the PCA to capture the value of the PCA counter/timer and load it into the corresponding module's 16-bit capture/compare register (PCA0CPLn and PCA0CPHn). The CAPPn and CAPNn bits in the PCA0CPMn register are used to select the type of transition that triggers the capture: low-to-high transition (positive edge), high-to-low transition (negative edge), or either transition (positive or negative edge). When a capture occurs, the Capture/Compare Flag (CCFn) in PCA0CN is set to logic 1. An interrupt request is generated if the CCFn interrupt for that module is enabled. The CCFn bit is not automatically cleared by hardware when the CPU vectors to the interrupt service routine, and must be cleared by software. If both CAPPn and CAPNn bits are set to logic 1, then the state of the Port pin associated with CEXn can be read directly to determine whether a rising-edge or falling-edge caused the capture.

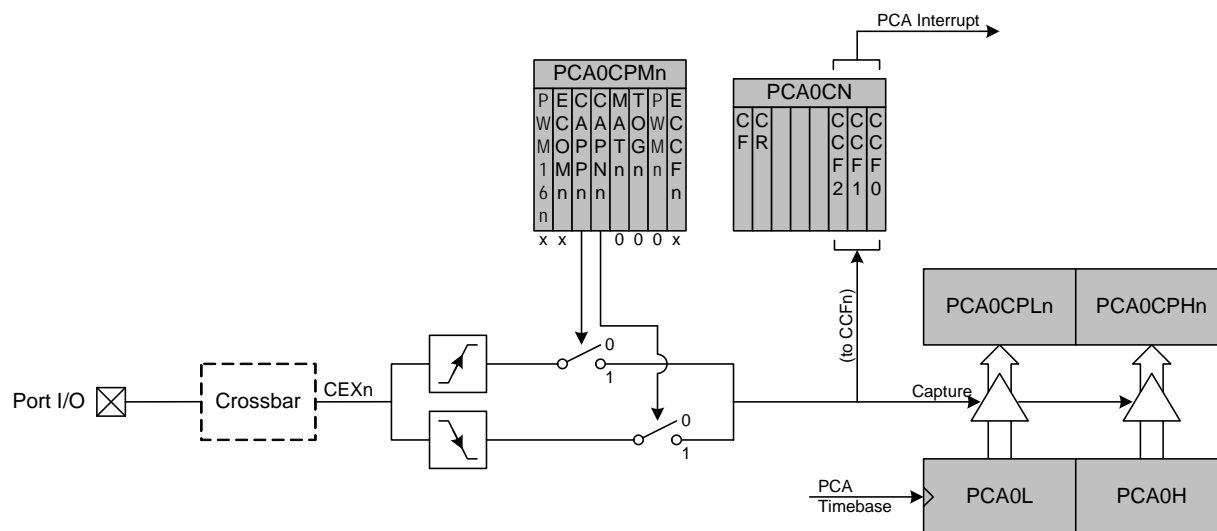

Figure 34.4. PCA Capture Mode Diagram

Note: The CEXn input signal must remain high or low for at least 2 system clock cycles to be recognized by the hardware.

34.3.2. Software Timer (Compare) Mode

In Software Timer mode, the PCA counter/timer value is compared to the module's 16-bit capture/compare register (PCA0CPHn and PCA0CPLn). When a match occurs, the Capture/Compare Flag (CCFn) in PCA0CN is set to logic 1. An interrupt request is generated if the CCFn interrupt for that module is enabled. The CCFn bit is not automatically cleared by hardware when the CPU vectors to the interrupt service routine, and must be cleared by software. Setting the ECOMn and MATn bits in the PCA0CPMn register enables Software Timer mode.

Important Note About Capture/Compare Registers: When writing a 16-bit value to the PCA0 Capture/Compare registers, the low byte should always be written first. Writing to PCA0CPLn clears the ECOMn bit to 0; writing to PCA0CPHn sets ECOMn to 1.

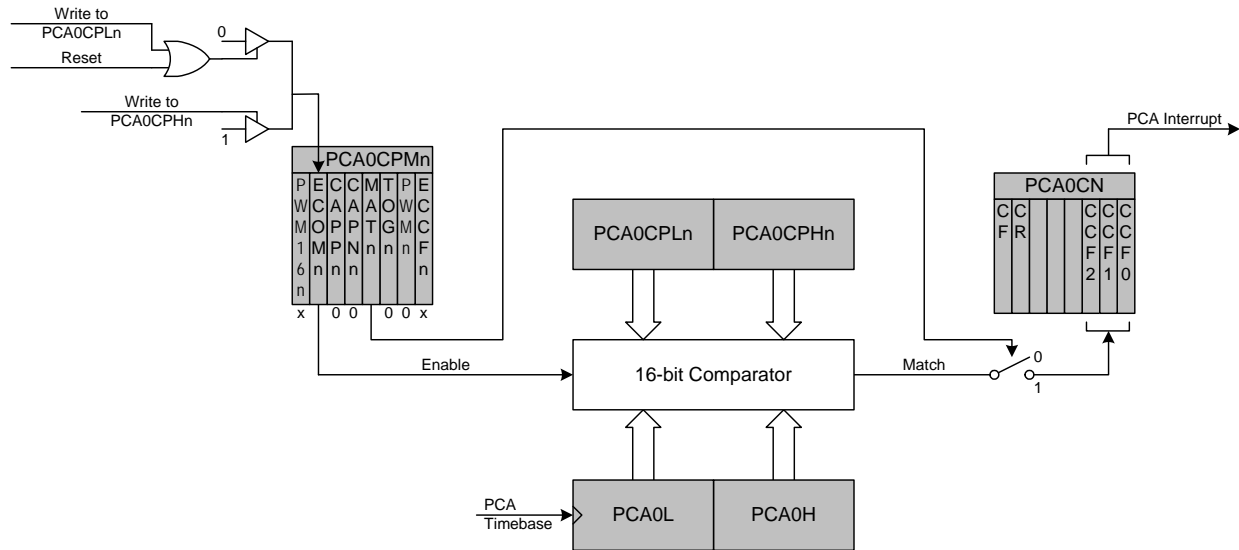

Figure 34.5. PCA Software Timer Mode Diagram

34.3.3. High-Speed Output Mode

In High-Speed Output mode, a module's associated CEXn pin is toggled each time a match occurs between the PCA Counter and the module's 16-bit capture/compare register (PCA0CPHn and PCA0CPLn). When a match occurs, the Capture/Compare Flag (CCFn) in PCA0CN is set to logic 1. An interrupt request is generated if the CCFn interrupt for that module is enabled. The CCFn bit is not automatically cleared by hardware when the CPU vectors to the interrupt service routine, and must be cleared by software. Setting the TOGn, MATn, and ECOMn bits in the PCA0CPMn register enables the High-Speed Output mode. If ECOMn is cleared, the associated pin will retain its state, and not toggle on the next match event.

Important Note About Capture/Compare Registers: When writing a 16-bit value to the PCA0 Capture/Compare registers, the low byte should always be written first. Writing to PCA0CPLn clears the ECOMn bit to 0; writing to PCA0CPHn sets ECOMn to 1.

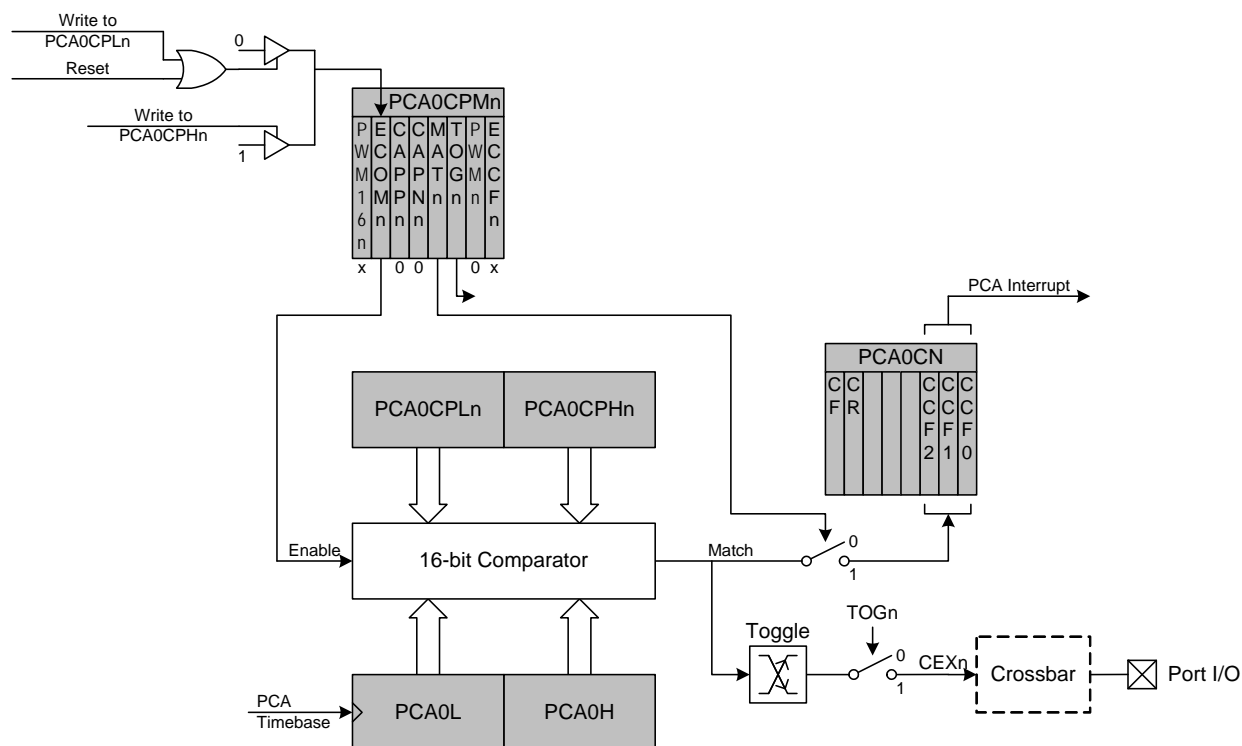

Figure 34.6. PCA High-Speed Output Mode Diagram

34.3.4. Frequency Output Mode

Frequency Output Mode produces a programmable-frequency square wave on the module’s associated CEXn pin. The capture/compare module high byte holds the number of PCA clocks to count before the output is toggled. The frequency of the square wave is then defined by Equation 34.1.

$$F_{CEXn} = \frac{F_{PCA}}{2 \times PCA0CPHn}$$

Note: A value of 0x00 in the PCA0CPHn register is equal to 256 for this equation.

Equation 34.1. Square Wave Frequency Output

Where F_{PCA} is the frequency of the clock selected by the CPS2–0 bits in the PCA mode register, PCA0MD. The lower byte of the capture/compare module is compared to the PCA counter low byte; on a match, CEXn is toggled and the offset held in the high byte is added to the matched value in PCA0CPLn. Frequency Output Mode is enabled by setting the ECOMn, TOGn, and PWMn bits in the PCA0CPMn register. The MATn bit should normally be set to 0 in this mode. If the MATn bit is set to 1, the CCFn flag for the channel will be set when the 16-bit PCA0 counter and the 16-bit capture/compare register for the channel are equal.

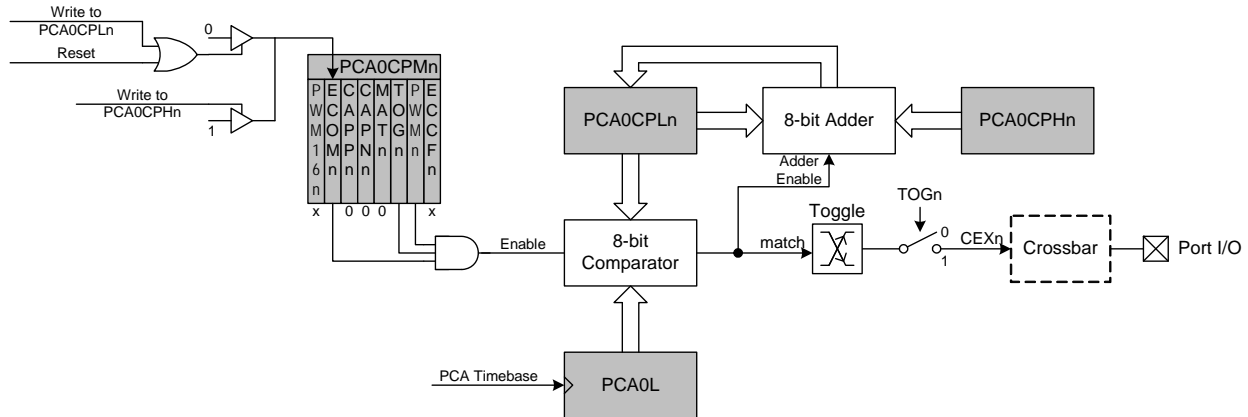

Figure 34.7. PCA Frequency Output Mode

34.3.5. 8-Bit, 9-Bit, 10-Bit and 11-Bit Pulse Width Modulator Modes

Each module can be used independently to generate a pulse width modulated (PWM) output on its associated CEXn pin. The frequency of the output is dependent on the timebase for the PCA counter/timer, and the setting of the PWM cycle length (8, 9, 10 or 11-bits). For backwards-compatibility with the 8-bit PWM mode available on other devices, the 8-bit PWM mode operates slightly different than 9, 10 and 11-bit PWM modes. **It is important to note that all channels configured for 8/9/10/11-bit PWM mode will use the same cycle length.** It is not possible to configure one channel for 8-bit PWM mode and another for 11-bit mode (for example). However, other PCA channels can be configured to Pin Capture, High-Speed Output, Software Timer, Frequency Output, or 16-bit PWM mode independently.

34.3.5.1. 8-Bit Pulse Width Modulator Mode

The duty cycle of the PWM output signal in 8-bit PWM mode is varied using the module's PCA0CPLn capture/compare register. When the value in the low byte of the PCA counter/timer (PCA0L) is equal to the value in PCA0CPLn, the output on the CEXn pin will be set. When the count value in PCA0L overflows, the CEXn output will be reset (see Figure 34.8). Also, when the counter/timer low byte (PCA0L) overflows from 0xFF to 0x00, PCA0CPLn is reloaded automatically with the value stored in the module's capture/compare high byte (PCA0CPHn) without software intervention. Setting the ECOMn and PWMn bits in the PCA0CPMn register, and setting the CLSEL bits in register PCA0PWM to 00b enables 8-Bit Pulse Width Modulator mode. If the MATn bit is set to 1, the CCFn flag for the module will be set each time an 8-bit comparator match (rising edge) occurs. The COVF flag in PCA0PWM can be used to detect the overflow (falling edge), which will occur every 256 PCA clock cycles. The duty cycle for 8-Bit PWM Mode is given in Equation 34.2.

Important Note About Capture/Compare Registers: When writing a 16-bit value to the PCA0 Capture/Compare registers, the low byte should always be written first. Writing to PCA0CPLn clears the ECOMn bit to 0; writing to PCA0CPHn sets ECOMn to 1.

$$\text{Duty Cycle} = \frac{(256 - \text{PCA0CPHn})}{256}$$

Equation 34.2. 8-Bit PWM Duty Cycle

Using Equation 34.2, the largest duty cycle is 100% (PCA0CPHn = 0), and the smallest duty cycle is 0.39% (PCA0CPHn = 0xFF). A 0% duty cycle may be generated by clearing the ECOMn bit to 0.

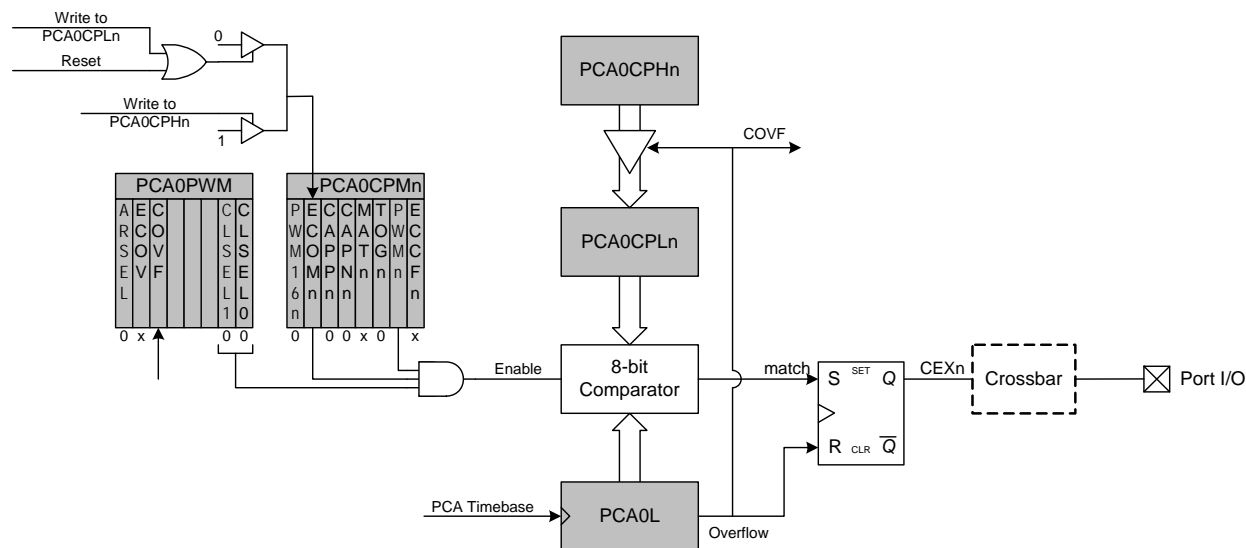

Figure 34.8. PCA 8-Bit PWM Mode Diagram

34.3.5.2. 9/10/11-bit Pulse Width Modulator Mode

The duty cycle of the PWM output signal in 9/10/11-bit PWM mode should be varied by writing to an “Auto-Reload” Register, which is dual-mapped into the PCA0CPHn and PCA0CPLn register locations. The data written to define the duty cycle should be right-justified in the registers. The auto-reload registers are accessed (read or written) when the bit ARSEL in PCA0PWN is set to 1. The capture/compare registers are accessed when ARSEL is set to 0.

When the least-significant N bits of the PCA0 counter match the value in the associated module’s capture/compare register (PCA0CPn), the output on CEXn is asserted high. When the counter overflows from the Nth bit, CEXn is asserted low (see Figure 34.9). Upon an overflow from the Nth bit, the COVF flag is set, and the value stored in the module’s auto-reload register is loaded into the capture/compare register. The value of N is determined by the CLSEL bits in register PCA0PWN.

The 9, 10 or 11-bit PWM mode is selected by setting the ECOMn and PWMn bits in the PCA0CPMn register, and setting the CLSEL bits in register PCA0PWN to the desired cycle length (other than 8-bits). If the MATn bit is set to 1, the CCFn flag for the module will be set each time a comparator match (rising edge) occurs. The COVF flag in PCA0PWN can be used to detect the overflow (falling edge), which will occur every 512 (9-bit), 1024 (10-bit) or 2048 (11-bit) PCA clock cycles. The duty cycle for 9/10/11-Bit PWM Mode is given in Equation 34.3, where N is the number of bits in the PWM cycle.

Important Note About PCA0CPHn and PCA0CPLn Registers: When writing a 16-bit value to the PCA0CPn registers, the low byte should always be written first. Writing to PCA0CPLn clears the ECOMn bit to 0; writing to PCA0CPHn sets ECOMn to 1.

$$\text{Duty Cycle} = \frac{(2^N - \text{PCA0CPn})}{2^N}$$

Equation 34.3. 9, 10, and 11-Bit PWM Duty Cycle

A 0% duty cycle may be generated by clearing the ECOMn bit to 0.

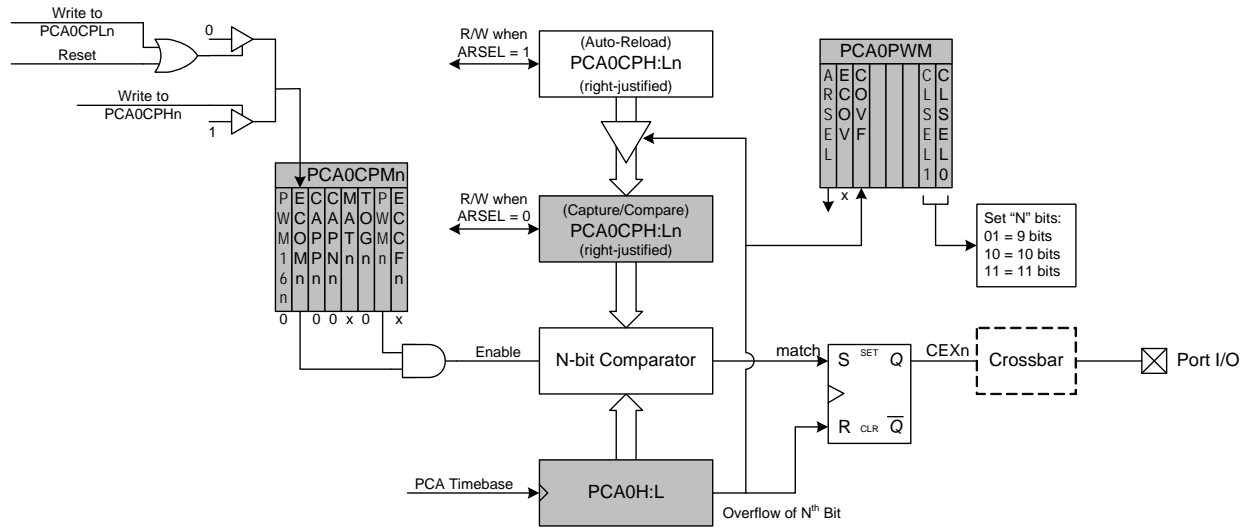

Figure 34.9. PCA 9, 10 and 11-Bit PWM Mode Diagram

34.3.6. 16-Bit Pulse Width Modulator Mode

A PCA module may also be operated in 16-Bit PWM mode. 16-bit PWM mode is independent of the other (8/9/10/11-bit) PWM modes. In this mode, the 16-bit capture/compare module defines the number of PCA clocks for the low time of the PWM signal. When the PCA counter matches the module contents, the output on CEXn is asserted high; when the 16-bit counter overflows, CEXn is asserted low. To output a varying duty cycle, new value writes should be synchronized with PCA CCFn match interrupts. 16-Bit PWM Mode is enabled by setting the ECOMn, PWMn, and PWM16n bits in the PCA0CPMn register. For a varying duty cycle, match interrupts should be enabled (ECCFn = 1 AND MATn = 1) to help synchronize the capture/compare register writes. If the MATn bit is set to 1, the CCFn flag for the module will be set each time a 16-bit comparator match (rising edge) occurs. The CF flag in PCA0CN can be used to detect the overflow (falling edge). The duty cycle for 16-Bit PWM Mode is given by Equation 34.4.

Important Note About Capture/Compare Registers: When writing a 16-bit value to the PCA0 Capture/Compare registers, the low byte should always be written first. Writing to PCA0CPLn clears the ECOMn bit to 0; writing to PCA0CPHn sets ECOMn to 1.

$$\text{Duty Cycle} = \frac{(65536 - \text{PCA0CPn})}{65536}$$

Equation 34.4. 16-Bit PWM Duty Cycle

Using Equation 34.4, the largest duty cycle is 100% (PCA0CPn = 0), and the smallest duty cycle is 0.0015% (PCA0CPn = 0xFFFF). A 0% duty cycle may be generated by clearing the ECOMn bit to 0.

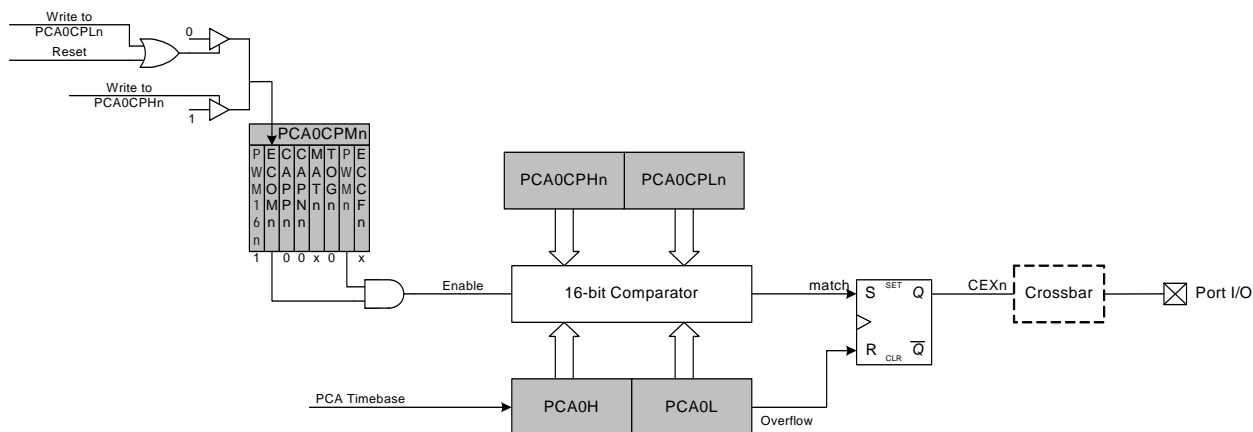

Figure 34.10. PCA 16-Bit PWM Mode

34.4. Watchdog Timer Mode

A programmable watchdog timer (WDT) function is available through the PCA Module 5. The WDT is used to generate a reset if the time between writes to the WDT update register (PCA0CPH2) exceed a specified limit. The WDT can be configured and enabled/disabled as needed by software.

With the WDTE bit set in the PCA0MD register, Module 5 operates as a watchdog timer (WDT). The Module 5 high byte is compared to the PCA counter high byte; the Module 5 low byte holds the offset to be used when WDT updates are performed. **The Watchdog Timer is enabled on reset. Writes to some PCA registers are restricted while the Watchdog Timer is enabled.** The WDT will generate a reset shortly after code begins execution. To avoid this reset, the WDT should be explicitly disabled (and optionally re-configured and re-enabled if it is used in the system).

34.4.1. Watchdog Timer Operation

While the WDT is enabled:

- PCA counter is forced on.
- Writes to PCA0L and PCA0H are not allowed.
- PCA clock source bits (CPS2–CPS0) are frozen.
- PCA Idle control bit (CIDL) is frozen.
- Module 5 is forced into software timer mode.
- Writes to the Module 5 mode register (PCA0CPM5) are disabled.

While the WDT is enabled, writes to the CR bit will not change the PCA counter state; the counter will run until the WDT is disabled. The PCA counter run control bit (CR) will read zero if the WDT is enabled but user software has not enabled the PCA counter. If a match occurs between PCA0CPH5 and PCA0H while the WDT is enabled, a reset will be generated. To prevent a WDT reset, the WDT may be updated with a write of any value to PCA0CPH5. Upon a PCA0CPH5 write, PCA0H plus the offset held in PCA0CPL5 is loaded into PCA0CPH5. (See Figure 34.11.)

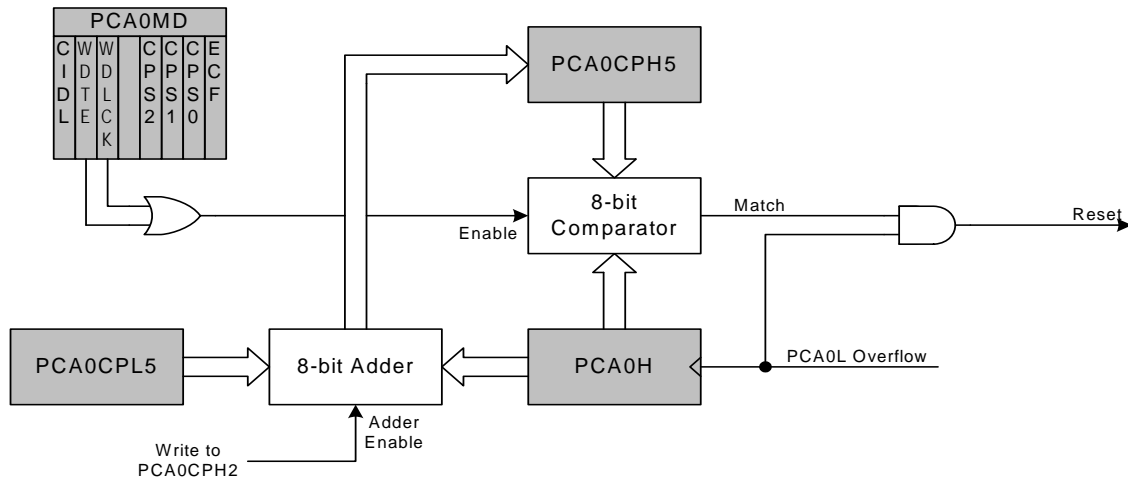

Figure 34.11. PCA Module 5 with Watchdog Timer Enabled

Note that the 8-bit offset held in PCA0CPH5 is compared to the upper byte of the 16-bit PCA counter. This offset value is the number of PCA0L overflows before a reset. Up to 256 PCA clocks may pass before the first PCA0L overflow occurs, depending on the value of the PCA0L when the update is performed. The total offset is then given (in PCA clocks) by Equation 34.5, where PCA0L is the value of the PCA0L register at the time of the update.

$$\text{Offset} = (256 \times \text{PCA0CPL5}) + (256 - \text{PCA0L})$$

Equation 34.5. Watchdog Timer Offset in PCA Clocks

The WDT reset is generated when PCA0L overflows while there is a match between PCA0CPH5 and PCA0H. Software may force a WDT reset by writing a 1 to the CCF5 flag (PCA0CN.5) while the WDT is enabled.

34.4.2. Watchdog Timer Usage

To configure the WDT, perform the following tasks:

- Disable the WDT by writing a 0 to the WDTE bit.
- Select the desired PCA clock source (with the CPS2–CPS0 bits).
- Load PCA0CPL5 with the desired WDT update offset value.
- Configure the PCA Idle mode (set CIDL if the WDT should be suspended while the CPU is in Idle mode).
- Enable the WDT by setting the WDTE bit to 1.
- Reset the WDT timer by writing to PCA0CPH5.

The PCA clock source and idle mode select cannot be changed while the WDT is enabled. The watchdog timer is enabled by setting the WDTE or WDLCK bits in the PCA0MD register. When WDLCK is set, the WDT cannot be disabled until the next system reset. If WDLCK is not set, the WDT is disabled by clearing the WDTE bit.

The WDT is enabled following any reset. The PCA0 counter clock defaults to the system clock divided by 12, PCA0L defaults to 0x00, and PCA0CPL5 defaults to 0x00. Using Equation 34.5, this results in a WDT timeout interval of 256 PCA clock cycles, or 3072 system clock cycles. Table 34.3 lists some example timeout intervals for typical system clocks.

Table 34.3. Watchdog Timer Timeout Intervals¹

System Clock (Hz)	PCA0CPL5	Timeout Interval (ms)
24,500,000	255	32.1
24,500,000	128	16.2
24,500,000	32	4.1
3,062,500 ²	255	257
3,062,500 ²	128	129.5
3,062,500 ²	32	33.1
32,000	255	24576
32,000	128	12384
32,000	32	3168

Notes:

1. Assumes SYSCLK/12 as the PCA clock source, and a PCA0L value of 0x00 at the update time.
2. Internal SYSCLK reset frequency = Internal Oscillator divided by 8.

34.5. Register Descriptions for PCA0

Following are detailed descriptions of the special function registers related to the operation of the PCA.

SFR Definition 34.1. PCA0CN: PCA Control

Bit	7	6	5	4	3	2	1	0
Name	CF	CR	CCF5	CCF4	CCF3	CCF2	CCF1	CCF0
Type	R/W	R/W	R/W	R/W	R/W	R/W	R/W	R/W
Reset	0	0	0	0	0	0	0	0

SFR Page = All Pages; SFR Address = 0xD8; Bit-Addressable

Bit	Name	Function
7	CF	<p>PCA Counter/Timer Overflow Flag.</p> <p>Set by hardware when the PCA Counter/Timer overflows from 0xFFFF to 0x0000. When the Counter/Timer Overflow (CF) interrupt is enabled, setting this bit causes the CPU to vector to the PCA interrupt service routine. This bit is not automatically cleared by hardware and must be cleared by software.</p>
6	CR	<p>PCA Counter/Timer Run Control.</p> <p>This bit enables/disables the PCA Counter/Timer. 0: PCA Counter/Timer disabled. 1: PCA Counter/Timer enabled.</p>
5:0	CCF[5:0]	<p>PCA Module n Capture/Compare Flag.</p> <p>These bits are set by hardware when a match or capture occurs in the associated PCA Module n. When the CCFn interrupt is enabled, setting this bit causes the CPU to vector to the PCA interrupt service routine. This bit is not automatically cleared by hardware and must be cleared by software.</p>

SFR Definition 34.2. PCA0MD: PCA Mode

Bit	7	6	5	4	3	2	1	0
Name	CIDL	WDTE	WDLCK		CPS2	CPS1	CPS0	ECF
Type	R/W	R/W	R/W	R	R/W	R/W	R/W	R/W
Reset	0	1	0	0	0	0	0	0

SFR Page = 0x0; SFR Address = 0xD9

Bit	Name	Function
7	CIDL	PCA Counter/Timer Idle Control. Specifies PCA behavior when CPU is in Idle Mode. 0: PCA continues to function normally while the system controller is in Idle Mode. 1: PCA operation is suspended while the system controller is in Idle Mode.
6	WDTE	Watchdog Timer Enable. If this bit is set, PCA Module 5 is used as the watchdog timer. 0: Watchdog Timer disabled. 1: PCA Module 5 enabled as Watchdog Timer.
5	WDLCK	Watchdog Timer Lock. This bit locks/unlocks the Watchdog Timer Enable. When WDLCK is set, the Watchdog Timer may not be disabled until the next system reset. 0: Watchdog Timer Enable unlocked. 1: Watchdog Timer Enable locked.
4	Unused	Read = 0b, Write = don't care.
3:1	CPS[2:0]	PCA Counter/Timer Pulse Select. These bits select the timebase source for the PCA counter 000: System clock divided by 12 001: System clock divided by 4 010: Timer 0 overflow 011: High-to-low transitions on ECI (max rate = system clock divided by 4) 100: System clock 101: External clock divided by 8 (synchronized with the system clock) 110: SmartClock divided by 8 (synchronized with the system clock) 111: Reserved
0	ECF	PCA Counter/Timer Overflow Interrupt Enable. This bit sets the masking of the PCA Counter/Timer Overflow (CF) interrupt. 0: Disable the CF interrupt. 1: Enable a PCA Counter/Timer Overflow interrupt request when CF (PCA0CN.7) is set.
Note: When the WDTE bit is set to 1, the other bits in the PCA0MD register cannot be modified. To change the contents of the PCA0MD register, the Watchdog Timer must first be disabled.		

SFR Definition 34.3. PCA0PWM: PCA PWM Configuration

Bit	7	6	5	4	3	2	1	0
Name	ARSEL	ECOV	COVF				CLSEL[1:0]	
Type	R/W	R/W	R/W	R	R	R	R/W	
Reset	0	0	0	0	0	0	0	0

SFR Page = 0x0; SFR Address = 0xDF

Bit	Name	Function
7	ARSEL	<p>Auto-Reload Register Select.</p> <p>This bit selects whether to read and write the normal PCA capture/compare registers (PCA0CPn), or the Auto-Reload registers at the same SFR addresses. This function is used to define the reload value for 9, 10, and 11-bit PWM modes. In all other modes, the Auto-Reload registers have no function.</p> <p>0: Read/Write Capture/Compare Registers at PCA0CPHn and PCA0CPLn. 1: Read/Write Auto-Reload Registers at PCA0CPHn and PCA0CPLn.</p>
6	ECOV	<p>Cycle Overflow Interrupt Enable.</p> <p>This bit sets the masking of the Cycle Overflow Flag (COVF) interrupt.</p> <p>0: COVF will not generate PCA interrupts. 1: A PCA interrupt will be generated when COVF is set.</p>
5	COVF	<p>Cycle Overflow Flag.</p> <p>This bit indicates an overflow of the 8th, 9th, 10th, or 11th bit of the main PCA counter (PCA0). The specific bit used for this flag depends on the setting of the Cycle Length Select bits. The bit can be set by hardware or software, but must be cleared by software.</p> <p>0: No overflow has occurred since the last time this bit was cleared. 1: An overflow has occurred since the last time this bit was cleared.</p>
4:2	Unused	Read = 000b; Write = don't care.
1:0	CLSEL[1:0]	<p>Cycle Length Select.</p> <p>When 16-bit PWM mode is not selected, these bits select the length of the PWM cycle, between 8, 9, 10, or 11 bits. This affects all channels configured for PWM which are not using 16-bit PWM mode. These bits are ignored for individual channels configured to 16-bit PWM mode.</p> <p>00: 8 bits. 01: 9 bits. 10: 10 bits. 11: 11 bits.</p>

SFR Definition 34.4. PCA0CPMn: PCA Capture/Compare Mode

Bit	7	6	5	4	3	2	1	0
Name	PWM16n	ECOMn	CAPPn	CAPNn	MATn	TOGn	PWMn	ECCFn
Type	R/W	R/W	R/W	R/W	R/W	R/W	R/W	R/W
Reset	0	0	0	0	0	0	0	0

SFR Address, Page: PCA0CPM0 = 0xDA, 0x0; PCA0CPM1 = 0xDB, 0x0; PCA0CPM2 = 0xDC, 0x0
 PCA0CPM3 = 0xDD, 0x0; PCA0CPM4 = 0xDE, 0x0; PCA0CPM5 = 0xCE, 0x0

Bit	Name	Function
7	PWM16n	16-bit Pulse Width Modulation Enable. This bit enables 16-bit mode when Pulse Width Modulation mode is enabled. 0: 8 to 11-bit PWM selected. 1: 16-bit PWM selected.
6	ECOMn	Comparator Function Enable. This bit enables the comparator function for PCA module n when set to 1.
5	CAPPn	Capture Positive Function Enable. This bit enables the positive edge capture for PCA module n when set to 1.
4	CAPNn	Capture Negative Function Enable. This bit enables the negative edge capture for PCA module n when set to 1.
3	MATn	Match Function Enable. This bit enables the match function for PCA module n when set to 1. When enabled, matches of the PCA counter with a module's capture/compare register cause the CCFn bit in PCA0MD register to be set to logic 1.
2	TOGn	Toggle Function Enable. This bit enables the toggle function for PCA module n when set to 1. When enabled, matches of the PCA counter with a module's capture/compare register cause the logic level on the CEXn pin to toggle. If the PWMn bit is also set to logic 1, the module operates in Frequency Output Mode.
1	PWMn	Pulse Width Modulation Mode Enable. This bit enables the PWM function for PCA module n when set to 1. When enabled, a pulse width modulated signal is output on the CEXn pin. 8 to 11-bit PWM is used if PWM16n is cleared; 16-bit mode is used if PWM16n is set to logic 1. If the TOGn bit is also set, the module operates in Frequency Output Mode.
0	ECCFn	Capture/Compare Flag Interrupt Enable. This bit sets the masking of the Capture/Compare Flag (CCFn) interrupt. 0: Disable CCFn interrupts. 1: Enable a Capture/Compare Flag interrupt request when CCFn is set.
<p>Note: When the WDTE bit is set to 1, the PCA0CPM5 register cannot be modified, and module 5 acts as the watchdog timer. To change the contents of the PCA0CPM5 register or the function of module 5, the Watchdog Timer must be disabled.</p>		

SFR Definition 34.5. PCA0L: PCA Counter/Timer Low Byte

Bit	7	6	5	4	3	2	1	0
Name	PCA0[7:0]							
Type	R/W	R/W	R/W	R/W	R/W	R/W	R/W	R/W
Reset	0	0	0	0	0	0	0	0

SFR Page = 0x0; SFR Address = 0xF9

Bit	Name	Function
7:0	PCA0[7:0]	PCA Counter/Timer Low Byte. The PCA0L register holds the low byte (LSB) of the 16-bit PCA Counter/Timer.
Note: When the WDTE bit is set to 1, the PCA0L register cannot be modified by software. To change the contents of the PCA0L register, the Watchdog Timer must first be disabled.		

SFR Definition 34.6. PCA0H: PCA Counter/Timer High Byte

Bit	7	6	5	4	3	2	1	0
Name	PCA0[15:8]							
Type	R/W	R/W	R/W	R/W	R/W	R/W	R/W	R/W
Reset	0	0	0	0	0	0	0	0

SFR Page = 0x0; SFR Address = 0xFA

Bit	Name	Function
7:0	PCA0[15:8]	PCA Counter/Timer High Byte. The PCA0H register holds the high byte (MSB) of the 16-bit PCA Counter/Timer. Reads of this register will read the contents of a “snapshot” register, whose contents are updated only when the contents of PCA0L are read (see Section 34.1).
Note: When the WDTE bit is set to 1, the PCA0H register cannot be modified by software. To change the contents of the PCA0H register, the Watchdog Timer must first be disabled.		

SFR Definition 34.7. PCA0CPLn: PCA Capture Module Low Byte

Bit	7	6	5	4	3	2	1	0
Name	PCA0CPn[7:0]							
Type	R/W	R/W	R/W	R/W	R/W	R/W	R/W	R/W
Reset	0	0	0	0	0	0	0	0

SFR Addresses: PCA0CPL0 = 0xFB, PCA0CPL1 = 0xE9, PCA0CPL2 = 0xEB,
PCA0CPL3 = 0xED, PCA0CPL4 = 0xFD, PCA0CPL5 = 0xD2

SFR Pages: PCA0CPL0 = 0x0, PCA0CPL1 = 0x0, PCA0CPL2 = 0x0,
PCA0CPL3 = 0x0, PCA0CPL4 = 0x0, PCA0CPL5 = 0x0

Bit	Name	Function
7:0	PCA0CPn[7:0]	<p>PCA Capture Module Low Byte.</p> <p>The PCA0CPLn register holds the low byte (LSB) of the 16-bit capture module n. This register address also allows access to the low byte of the corresponding PCA channel's auto-reload value for 9, 10, or 11-bit PWM mode. The ARSEL bit in register PCA0PWM controls which register is accessed.</p>
<p>Note: A write to this register will clear the module's ECOMn bit to a 0.</p>		

SFR Definition 34.8. PCA0CPHn: PCA Capture Module High Byte

Bit	7	6	5	4	3	2	1	0
Name	PCA0CPn[15:8]							
Type	R/W	R/W	R/W	R/W	R/W	R/W	R/W	R/W
Reset	0	0	0	0	0	0	0	0

SFR Addresses: PCA0CPH0 = 0xFC, PCA0CPH1 = 0xEA, PCA0CPH2 = 0xEC,
PCA0CPH3 = 0xEE, PCA0CPH4 = 0xFE, PCA0CPH5 = 0xD3

SFR Pages: PCA0CPH0 = 0x0, PCA0CPH1 = 0x0, PCA0CPH2 = 0x0,
PCA0CPH3 = 0x0, PCA0CPH4 = 0x0, PCA0CPH5 = 0x0

Bit	Name	Function
7:0	PCA0CPn[15:8]	<p>PCA Capture Module High Byte.</p> <p>The PCA0CPHn register holds the high byte (MSB) of the 16-bit capture module n. This register address also allows access to the high byte of the corresponding PCA channel's auto-reload value for 9, 10, or 11-bit PWM mode. The ARSEL bit in register PCA0PWM controls which register is accessed.</p>
<p>Note: A write to this register will set the module's ECOMn bit to a 1.</p>		

35. C2 Interface

Si102x/3x devices include an on-chip Silicon Labs 2-Wire (C2) debug interface to allow Flash programming and in-system debugging with the production part installed in the end application. The C2 interface uses a clock signal (C2CK) and a bi-directional C2 data signal (C2D) to transfer information between the device and a host system. See the C2 Interface Specification for details on the C2 protocol.

35.1. C2 Interface Registers

The following describes the C2 registers necessary to perform Flash programming through the C2 interface. All C2 registers are accessed through the C2 interface as described in the C2 Interface Specification.

C2 Register Definition 35.1. C2ADD: C2 Address

Bit	7	6	5	4	3	2	1	0
Name	C2ADD[7:0]							
Type	R/W							
Reset	0	0	0	0	0	0	0	0

Bit	Name	Function										
7:0	C2ADD[7:0]	<p>C2 Address. The C2ADD register is accessed via the C2 interface to select the target Data register for C2 Data Read and Data Write commands.</p> <table border="1"> <thead> <tr> <th>Address</th> <th>Description</th> </tr> </thead> <tbody> <tr> <td>0x00</td> <td>Selects the Device ID register for Data Read instructions</td> </tr> <tr> <td>0x01</td> <td>Selects the Revision ID register for Data Read instructions</td> </tr> <tr> <td>0x02</td> <td>Selects the C2 Flash Programming Control register for Data Read/Write instructions</td> </tr> <tr> <td>0xB4</td> <td>Selects the C2 Flash Programming Data register for Data Read/Write instructions</td> </tr> </tbody> </table>	Address	Description	0x00	Selects the Device ID register for Data Read instructions	0x01	Selects the Revision ID register for Data Read instructions	0x02	Selects the C2 Flash Programming Control register for Data Read/Write instructions	0xB4	Selects the C2 Flash Programming Data register for Data Read/Write instructions
Address	Description											
0x00	Selects the Device ID register for Data Read instructions											
0x01	Selects the Revision ID register for Data Read instructions											
0x02	Selects the C2 Flash Programming Control register for Data Read/Write instructions											
0xB4	Selects the C2 Flash Programming Data register for Data Read/Write instructions											

Si102x/3x

C2 Register Definition 35.2. DEVICEID: C2 Device ID

Bit	7	6	5	4	3	2	1	0
Name	DEVICEID[7:0]							
Type	R/W							
Reset	0	0	0	1	0	1	0	0

C2 Address: 0x00

Bit	Name	Function
7:0	DEVICEID[7:0]	Device ID. This read-only register returns the 8-bit device ID: 0x2A (Si102x/3x).

C2 Register Definition 35.3. REVID: C2 Revision ID

Bit	7	6	5	4	3	2	1	0
Name	REVID[7:0]							
Type	R/W							
Reset	Varies	Varies	Varies	Varies	Varies	Varies	Varies	Varies

C2 Address: 0x01

Bit	Name	Function
7:0	REVID[7:0]	Revision ID. This read-only register returns the 8-bit revision ID. For example: 0x00 = Revision A.

C2 Register Definition 35.4. FPCTL: C2 Flash Programming Control

Bit	7	6	5	4	3	2	1	0
Name	FPCTL[7:0]							
Type	R/W							
Reset	0	0	0	0	0	0	0	0

C2 Address: 0x02

Bit	Name	Function
7:0	FPCTL[7:0]	<p>Flash Programming Control Register.</p> <p>This register is used to enable Flash programming via the C2 interface. To enable C2 Flash programming, the following codes must be written in order: 0x02, 0x01. Note that once C2 Flash programming is enabled, a system reset must be issued to resume normal operation.</p>

C2 Register Definition 35.5. FPDAT: C2 Flash Programming Data

Bit	7	6	5	4	3	2	1	0
Name	FPDAT[7:0]							
Type	R/W							
Reset	0	0	0	0	0	0	0	0

C2 Address: 0xB4

Bit	Name	Function										
7:0	FPDAT[7:0]	<p>C2 Flash Programming Data Register.</p> <p>This register is used to pass Flash commands, addresses, and data during C2 Flash accesses. Valid commands are listed below.</p> <table border="1"> <thead> <tr> <th>Code</th> <th>Command</th> </tr> </thead> <tbody> <tr> <td>0x06</td> <td>Flash Block Read</td> </tr> <tr> <td>0x07</td> <td>Flash Block Write</td> </tr> <tr> <td>0x08</td> <td>Flash Page Erase</td> </tr> <tr> <td>0x03</td> <td>Device Erase</td> </tr> </tbody> </table>	Code	Command	0x06	Flash Block Read	0x07	Flash Block Write	0x08	Flash Page Erase	0x03	Device Erase
Code	Command											
0x06	Flash Block Read											
0x07	Flash Block Write											
0x08	Flash Page Erase											
0x03	Device Erase											

35.2. C2 Pin Sharing

The C2 protocol allows the C2 pins to be shared with user functions so that in-system debugging and Flash programming may be performed. This is possible because C2 communication is typically performed when the device is in the halt state, where all on-chip peripherals and user software are stalled. In this halted state, the C2 interface can safely "borrow" the C2CK ($\overline{\text{RST}}$) and C2D pins. In most applications, external resistors are required to isolate C2 interface traffic from the user application. A typical isolation configuration is shown in Figure 35.1.

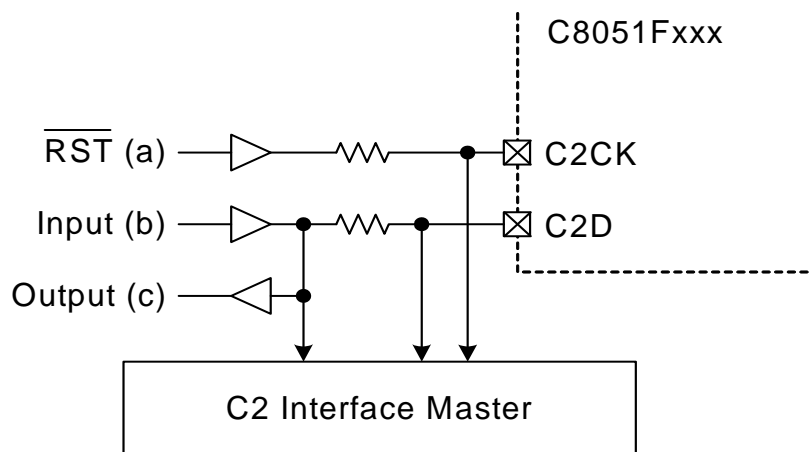

Figure 35.1. Typical C2 Pin Sharing

The configuration in Figure 35.1 assumes the following:

1. The user input (b) cannot change state while the target device is halted.
2. The $\overline{\text{RST}}$ pin on the target device is used as an input only.

Additional resistors may be necessary depending on the specific application.

NOTES:

Si102x/3x

CONTACT INFORMATION

Silicon Laboratories Inc.

400 West Cesar Chavez
Austin, TX 78701

Please visit the Silicon Labs Technical Support web page:
<https://www.silabs.com/support/pages/contacttechnicalsupport.aspx>
and register to submit a technical support request.

The information in this document is believed to be accurate in all respects at the time of publication but is subject to change without notice. Silicon Laboratories assumes no responsibility for errors and omissions, and disclaims responsibility for any consequences resulting from the use of information included herein. Additionally, Silicon Laboratories assumes no responsibility for the functioning of undescribed features or parameters. Silicon Laboratories reserves the right to make changes without further notice. Silicon Laboratories makes no warranty, representation or guarantee regarding the suitability of its products for any particular purpose, nor does Silicon Laboratories assume any liability arising out of the application or use of any product or circuit, and specifically disclaims any and all liability, including without limitation consequential or incidental damages. Silicon Laboratories products are not designed, intended, or authorized for use in applications intended to support or sustain life, or for any other application in which the failure of the Silicon Laboratories product could create a situation where personal injury or death may occur. Should Buyer purchase or use Silicon Laboratories products for any such unintended or unauthorized application, Buyer shall indemnify and hold Silicon Laboratories harmless against all claims and damages.

Silicon Laboratories and Silicon Labs are trademarks of Silicon Laboratories Inc.

Other products or brandnames mentioned herein are trademarks or registered trademarks of their respective holders.



Стандарт Электрон Связь

Мы молодая и активно развивающаяся компания в области поставок электронных компонентов. Мы поставляем электронные компоненты отечественного и импортного производства напрямую от производителей и с крупнейших складов мира.

Благодаря сотрудничеству с мировыми поставщиками мы осуществляем комплексные и плановые поставки широчайшего спектра электронных компонентов.

Собственная эффективная логистика и склад в обеспечивает надежную поставку продукции в точно указанные сроки по всей России.

Мы осуществляем техническую поддержку нашим клиентам и предпродажную проверку качества продукции. На все поставляемые продукты мы предоставляем гарантию .

Осуществляем поставки продукции под контролем ВП МО РФ на предприятия военно-промышленного комплекса России , а также работаем в рамках 275 ФЗ с открытием отдельных счетов в уполномоченном банке. Система менеджмента качества компании соответствует требованиям ГОСТ ISO 9001.

Минимальные сроки поставки, гибкие цены, неограниченный ассортимент и индивидуальный подход к клиентам являются основой для выстраивания долгосрочного и эффективного сотрудничества с предприятиями радиоэлектронной промышленности, предприятиями ВПК и научно-исследовательскими институтами России.

С нами вы становитесь еще успешнее!

Наши контакты:

Телефон: +7 812 627 14 35

Электронная почта: sales@st-electron.ru

Адрес: 198099, Санкт-Петербург,
Промышленная ул, дом № 19, литера Н,
помещение 100-Н Офис 331