

NHD-19232WG-BTMI-V#T

Graphic Liquid Crystal Display Module

NHD-	Newhaven Display
19232-	192 x 32 pixels
WG-	Display Type: Graphic
B-	Model
T-	White LED Backlight
M-	STN-Blue (-)
I-	Transmissive, 6:00 view, Wide Temp. (-20°C ~ +70°C)
V#T-	Built-in Positive Voltage
	RoHS Compliant

Newhaven Display International, Inc.

2511 Technology Drive, Suite 101

Elgin IL, 60124

Ph: 847-844-8795

Fax: 847-844-8796

www.newhavendisplay.com

nhtech@newhavendisplay.com

nhsales@newhavendisplay.com

Document Revision History

Revision	Date	Description	Changed by
0	10/9/2007	Initial Release	-
1	11/27/2008	Backlight info updated	-
2	4/20/2010	User guide reformat	BE

Functions and Features

- 192 x 32 pixels
- Built-in ST7920 controller
- +5.0V Power Supply
- 1/32 duty
- RoHS Compliant

Mechanical Drawing

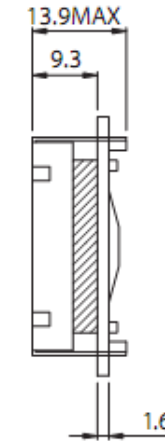
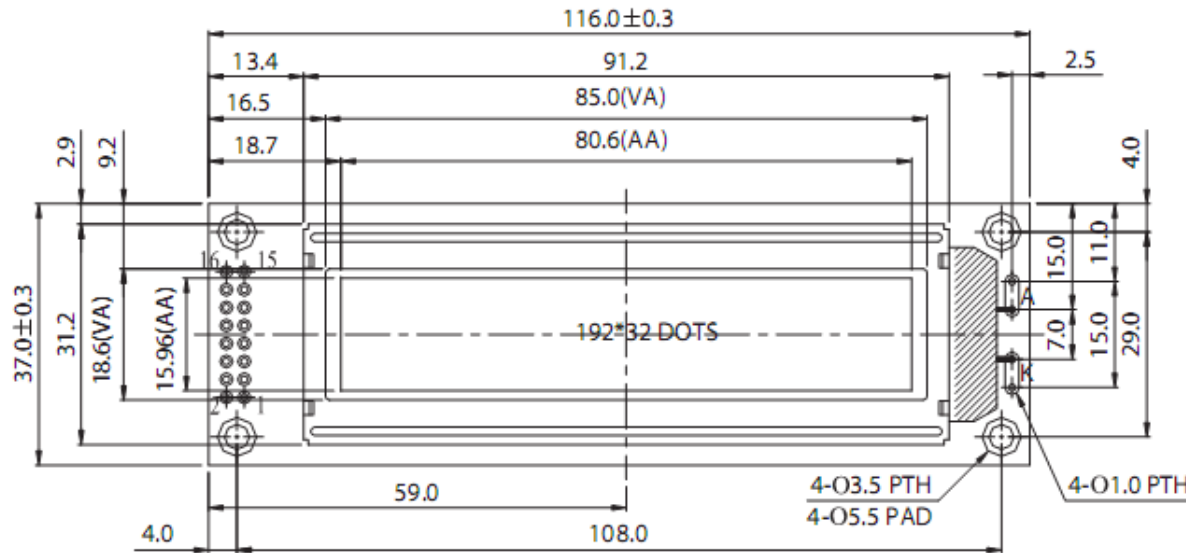

PIN NO.	SYMBOL
1	Vss
2	VDD
3	V0
4	RS
5	R/W
6	E
7	DB0
8	DB1
9	DB2
10	DB3
11	DB4
12	DB5
13	DB6
14	DB7
15	Vout
16	NC

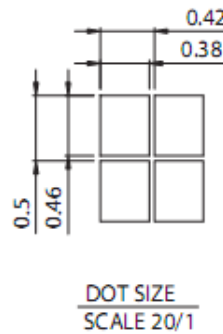
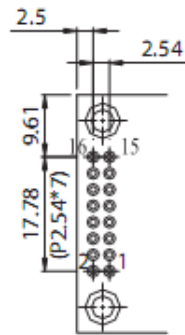

Newhaven Display

NHD-19232WG-BTMI-V#T

Pin Description and Wiring Diagram

Pin No.	Symbol	External Connection	Function Description
1	VSS	Power Supply	Ground
2	VDD	Power Supply	Power supply for logic (+5.0V)
3	V0	Adj. Power Supply	Power Supply for contrast (approx. 0.5V)
4	RS	MPU	Register select signal. RS=0: Command, RS=1: Data
5	R/W	MPU	Read/Write select signal, R/W=1: Read R/W: =0: Write
6	E	MPU	Operation enable signal. Falling edge triggered.
7-14	DB0-DB7	MPU	Bi-directional 8-bit data bus
15	Vout	Power Supply	Positive voltage output (+5.0V)
16	NC	-	No Connect
A	LED+	Power Supply	Power supply for LED Backlight (+3.5V)
K	LED-	Power Supply	Ground for Backlight

Recommended LCD connector: 2.54mm pitch pins

Backlight connector: - Mates with: -

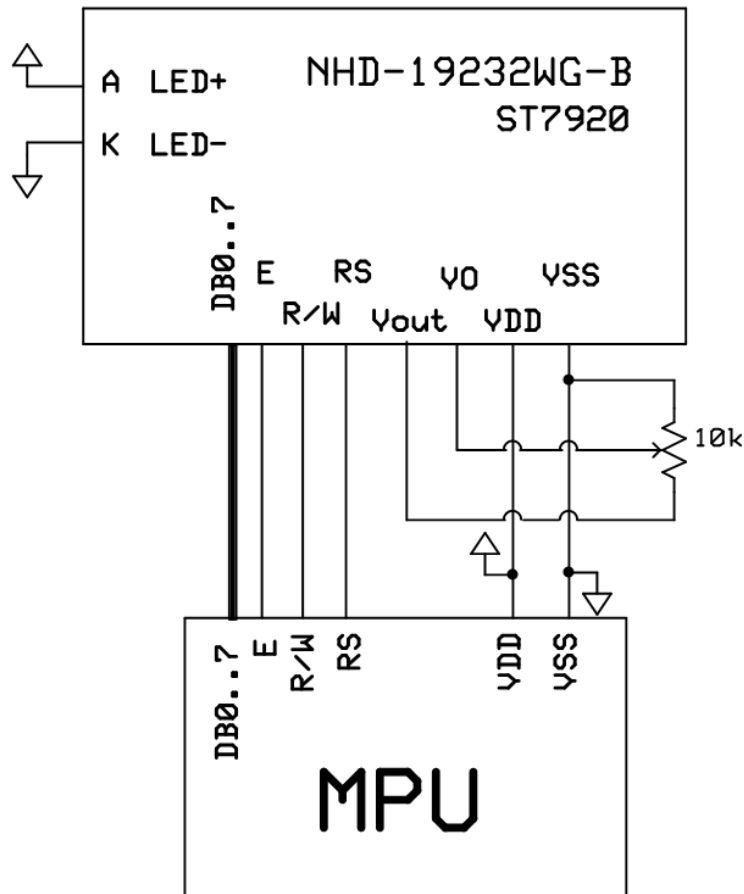

Electrical Characteristics

Item	Symbol	Condition	Min.	Typ.	Max.	Unit
Operating Temperature Range	Top	Absolute Max	-20	-	+70	°C
Storage Temperature Range	Tst	Absolute Max	-30	-	+80	°C
Supply Voltage	VDD		4.5	5.0	5.5	V
Supply Current	IDD	VDD=5.0V	1.5	2.0	2.8	mA
Supply for LCD (contrast)	VDD-V0	Ta=25°C	-	4.5	-	V
"H" Level input	VIH		0.7VDD	-	VDD	V
"L" Level input	VIL		-0.3	-	0.6	V
"H" Level output	VOH		0.8VDD	-	VDD	V
"L" Level output	VOL		0	-	0.4	V
Backlight Supply Voltage	Vled	-	3.4	3.5	3.6	V
Backlight Supply Current	Iled	Vled=3.5V	28.8	32	50	mA
Backlight Lifetime	-	Iled=32mA	-	50,000	-	Hrs.

Optical Characteristics

Item	Symbol	Condition	Min.	Typ.	Max.	Unit
Viewing Angle - Vertical	AV	Cr ≥ 2	-	20	-	°
Viewing Angle - Vertical	AV	Cr ≥ 2	-	40	-	°
Viewing Angle – Horizontal	AH	Cr ≥ 2	-	30	-	°
Viewing Angle - Horizontal	AH	Cr ≥ 2	-	30	-	°
Contrast Ratio	Cr		-	3	-	-
Response Time (rise)	Tr	-	-	150	200	ms
Response Time (fall)	Tf	-	-	150	200	ms

Controller Information

Built-in ST7920. Download specification at http://www.newhavendisplay.com/app_notes/ST7920.pdf

Table of Commands

Ins	code										Description	Exec time (540KHZ)
	RS	RW	DB7	DB6	DB5	DB4	DB3	DB2	DB1	DB0		
CLEAR	0	0	0	0	0	0	0	0	0	1	Fill DDRAM with "20H", and set DDRAM address counter (AC) to "00H"	1.6 ms
HOME	0	0	0	0	0	0	0	0	0	1 X	Set DDRAM address counter (AC) to "00H", and put cursor to origin ; the content of DDRAM are not changed	72us
ENTRY MODE	0	0	0	0	0	0	0	0	1	I/D S	Set cursor position and display shift when doing write or read operation	72us
DISPLAY ON/OFF	0	0	0	0	0	0	0	1	D	C B	D=1: display ON C=1: cursor ON B=1: blink ON	72 us
CURSOR DISPLAY CONTROL	0	0	0	0	0	1	S/C	R/L	X	X	Cursor position and display shift control ; the content of DDRAM are not changed	72 us
FUNCTION SET	0	0	0	0	1	DL	X	0 RE	X	X	DL=1 8-BIT interface DL=0 4-BIT interface RE=1: extended instruction RE=0: basic instruction	72 us
SET CGRAM ADDR.	0	0	0	1	AC5	AC4	AC3	AC2	AC1	AC0	Set CGRAM address to address counter (AC) Make sure that in extended instruction SR=0 (scroll or RAM address select)	72 us
SET DDRAM ADDR.	0	0	1	0 AC6	AC5	AC4	AC3	AC2	AC1	AC0	Set DDRAM address to address counter (AC) AC6 is fixed to 0	72 us
READ BUSY FLAG (BF) & ADDR.	0	1	BF	AC6	AC5	AC4	AC3	AC2	AC1	AC0	Read busy flag (BF) for completion of internal operation, also Read out the value of address counter (AC)	0 us
WRITE RAM	1	0	D7	D6	D5	D4	D3	D2	D1	D0	Write data to internal RAM (DDRAM/CGRAM/IRAM/GDRAM)	72 us
READ RAM	1	1	D7	D6	D5	D4	D3	D2	D1	D0	Read data from internal RAM (DDRAM/CGRAM/IRAM/GDRAM)	72 us

Inst.	code										description	Exec. time (540KHZ)
	RS	RW	DB7	DB6	DB5	DB4	DB3	DB2	DB1	DB0		
STAND BY	0	0	0	0	0	0	0	0	0	1	Enter stand by mode, any other instruction can terminate (Com1..32 halted, only Com33 ICON can display)	72 us
SCROLL or RAM ADDR. SELECT	0	0	0	0	0	0	0	0	0	1	SR=1: enable vertical scroll position SR=0: enable IRAM address (extended instruction) SR=0: enable CGRAM address(basic instruction)	72 us
REVERSE	0	0	0	0	0	0	0	0	1	R1 R0	Select 1 out of 4 line (in DDRAM) and decide whether to reverse the display by toggling this instruction R1,R0 initial value is 00	72 us
EXTENDED FUNCTION SET	0	0	0	0	1	DL	X	1	RE	G	DL=1 8-BIT interface DL=0 4-BIT interface RE=1: extended instruction set RE=0: basic instruction set G=1 :graphic display ON G=0 :graphic display OFF	72 us
SET IRAM or SCROLL ADDR	0	0	0	1	AC5	AC4	AC3	AC2	AC1	AC0	SR=1: AC5~AC0 the address of vertical scroll SR=0: AC3~AC0 the address of ICON RAM	72 us
SET GRAPHIC RAM ADDR.	0	0	1	0	0	0	AC3	AC2	AC1	AC0	Set GDRAM address to address counter (AC) First set vertical address and the horizontal address by consecutive writing Vertical address range AC6...AC0 Horizontal address range AC3...AC0	72 us

Timing Characteristics

($T_A = 25^\circ\text{C}$, $V_{DD} = 4.5\text{ V} - 5.5\text{ V}$)

Symbol	Characteristics	Test Condition	Min.	Typ.	Max.	Unit
V_{DD}	Operating Voltage	-	4.5	-	5.5	V
V_{LCD}	LCD Voltage	$V_0 - V_{SS}$	3.0	-	7	V
I_{CC}	Power Supply Current	$f_{OSC} = 540\text{KHz}$, $V_{DD}=5\text{V}$ $R_f=33\text{K}\ \Omega$	-	0.45	0.75	mA
V_{IH1}	Input High Voltage (Except OSC1)	-	$0.7V_{DD}$	-	V_{DD}	V
V_{IL1}	Input Low Voltage (Except OSC1)	-	-0.3	-	0.6	V
V_{IH2}	Input High Voltage (OSC1)	-	$V_{DD}-1$	-	V_{DD}	V
V_{IL2}	Input Low Voltage (OSC1)	-	-	-	1.0	V
V_{OH1}	Output High Voltage (DB0 - DB7)	$I_{OH} = -0.1\text{mA}$	$0.8V_{DD}$	-	V_{DD}	V
V_{OL1}	Output Low Voltage (DB0 - DB7)	$I_{OL} = 0.1\text{mA}$	-	-	0.4	V
V_{OH2}	Output High Voltage (Except DB0 - DB7)	$I_{OH} = -0.04\text{mA}$	$0.8V_{DD}$	-	V_{DD}	V
V_{OL2}	Output Low Voltage (Except DB0 - DB7)	$I_{OL} = 0.04\text{mA}$	-	-	$0.1V_{DD}$	V
I_{LEAK}	Input Leakage Current	$V_{IN} = 0\text{V to } V_{DD}$	-1	-	1	μA
I_{PUP}	Pull Up MOS Current	$V_{DD} = 5\text{V}$	75	80	85	μA

MPU write data to ST7920

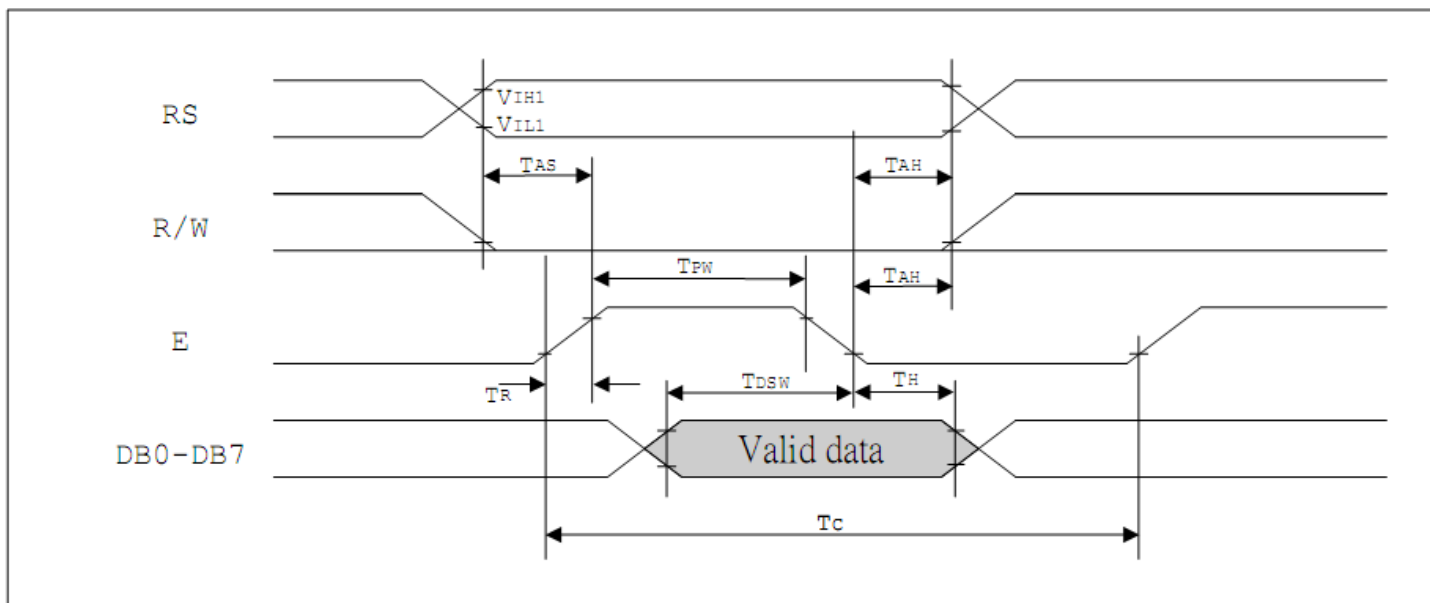

MPU read data from ST7920

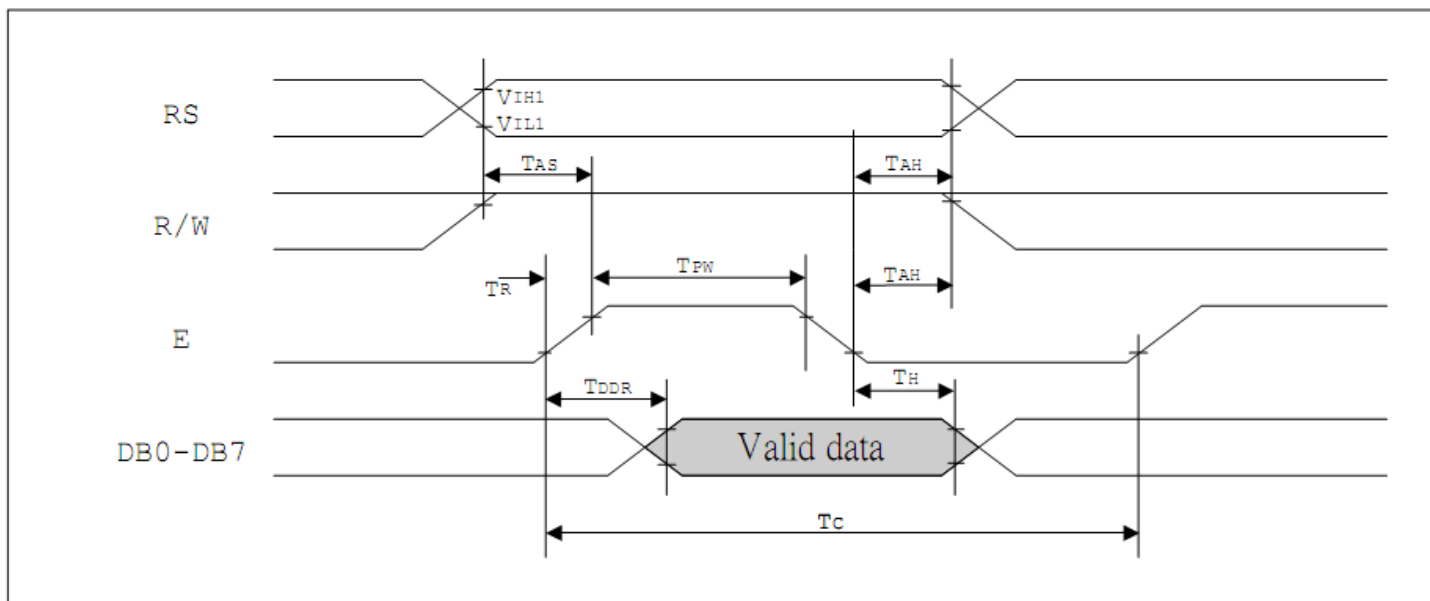

Example Initialization Program

```
//-----  
void Init()  
{  
    Wcom(0x38);  
    Wcom(0x0C);  
    Wcom(0x06);  
    Wcom(0x02);  
    Wcom(0x01);  
    delay(10);  
    Row = 0x80;  
    for(Counthi = 1; Counthi <=32; Counthi++)  
    {  
        Wcom(0x3E);  
        Wcom(Row);  
        Wcom(0x80);  
        for(Count = 1; Count <=40; Count++)  
        {  
            Wdata(0x00);  
        }  
        Row++;  
    }  
}  
//-----  
void Wcom(char i)  
{  
    P1 = i;  
    ID = 0;  
    RW = 0;  
    E = 1;  
    delay(2);  
    E = 0;  
}  
  
void Wdata(char i)  
{  
    P1 = i;  
    ID = 1;  
    RW = 0;  
    E = 1;  
    delay(2);  
    E = 0;  
}  
//-----
```

Quality Information

Test Item	Content of Test	Test Condition	Note
High Temperature storage	Endurance test applying the high storage temperature for a long time.	+80°C , 200hrs	2
Low Temperature storage	Endurance test applying the low storage temperature for a long time.	-30°C , 200hrs	1,2
High Temperature Operation	Endurance test applying the electric stress (voltage & current) and the high thermal stress for a long time.	+70°C 200hrs	2
Low Temperature Operation	Endurance test applying the electric stress (voltage & current) and the low thermal stress for a long time.	-20°C , 200hrs	1,2
High Temperature / Humidity Operation	Endurance test applying the electric stress (voltage & current) and the high thermal with high humidity stress for a long time.	+60°C , 90% RH , 96hrs	1,2
Thermal Shock resistance	Endurance test applying the electric stress (voltage & current) during a cycle of low and high thermal stress.	-20°C,30min -> 25°C,5min -> 70°C,30min = 1 cycle 10 cycles	
Vibration test	Endurance test applying vibration to simulate transportation and use.	10-55Hz , 15mm amplitude. 60 sec in each of 3 directions X,Y,Z For 15 minutes	3
Static electricity test	Endurance test applying electric static discharge.	VS=800V, RS=1.5kΩ, CS=100pF One time	

Note 1: No condensation to be observed.

Note 2: Conducted after 4 hours of storage at 25°C, 0%RH.

Note 3: Test performed on product itself, not inside a container.

Precautions for using LCDs/LCMs

See Precautions at www.newhavendisplay.com/specs/precautions.pdf

Warranty Information and Terms & Conditions

http://www.newhavendisplay.com/index.php?main_page=terms



Стандарт Электрон Связь

Мы молодая и активно развивающаяся компания в области поставок электронных компонентов. Мы поставляем электронные компоненты отечественного и импортного производства напрямую от производителей и с крупнейших складов мира.

Благодаря сотрудничеству с мировыми поставщиками мы осуществляем комплексные и плановые поставки широчайшего спектра электронных компонентов.

Собственная эффективная логистика и склад в обеспечивает надежную поставку продукции в точно указанные сроки по всей России.

Мы осуществляем техническую поддержку нашим клиентам и предпродажную проверку качества продукции. На все поставляемые продукты мы предоставляем гарантию .

Осуществляем поставки продукции под контролем ВП МО РФ на предприятия военно-промышленного комплекса России , а также работаем в рамках 275 ФЗ с открытием отдельных счетов в уполномоченном банке. Система менеджмента качества компании соответствует требованиям ГОСТ ISO 9001.

Минимальные сроки поставки, гибкие цены, неограниченный ассортимент и индивидуальный подход к клиентам являются основой для выстраивания долгосрочного и эффективного сотрудничества с предприятиями радиоэлектронной промышленности, предприятиями ВПК и научно-исследовательскими институтами России.

С нами вы становитесь еще успешнее!

Наши контакты:

Телефон: +7 812 627 14 35

Электронная почта: sales@st-electron.ru

Адрес: 198099, Санкт-Петербург,
Промышленная ул, дом № 19, литера Н,
помещение 100-Н Офис 331