

DESCRIPTION

The MP2681 is a highly integrated Li-Ion or Li-polymer switch mode battery charge controller with full protection and status indication. This part integrates a precision voltage reference and charge status indications suitable for AC adapter input and cradle charger applications.

The MP2681 automatically detects the battery cell through a battery ID resistor and regulates the battery voltage according to the corresponding cell configurations: 3S1P, 3S2P, 4S1P, 4S2P, 5S1P and 5S2P. Then, the AC adapter output is automatically regulated according to the battery configuration chosen. Additionally, if the battery pack does not have an ID resistor, the charge termination voltage can be configured by setting a dedicated voltage to the ID pin according to the six pre-set VID values representing each battery configuration. The MP2681 charges the battery in three phases: pre-charge, constant current and constant voltage. Charge is terminated when the current reaches a minimum set level. An internal charge timer provides safety backup. The MP2681 provides a fixed pre-charge mode for deeply-discharged batteries and safety features that include battery temperature monitoring, NTC control, charge time-out and fault control.

MP2681 is available in a 16-pin SOIC package.

FEATURES

- Constant Voltage and Constant Current Control
- Pre-Charge Mode for Deeply-discharged Battery
- Automatic Battery Cell Detection
- Two 1MHz Bandwidth Operational Amplifiers Output Connected with OR Logic
- Wide Input Voltage Range: 4.5V to 30V
- Auto-Recharge
- Charge On/Off Control
- Programmable Internal Timer
- Battery Temperature Monitoring
- Charge Status Indication
- Power Line Fault Detection
- Over Temperature Protection
- 16-pin SOIC Package

APPLICATIONS

- Battery Charger for Portable Tools
- Standalone Fast Charger

All MPS parts are lead-free and adhere to the RoHS directive. For MPS green status, please visit MPS website under Quality Assurance. "MPS" and "The Future of Analog IC Technology" are Registered Trademarks of Monolithic Power Systems, Inc.

TYPICAL APPLICATION

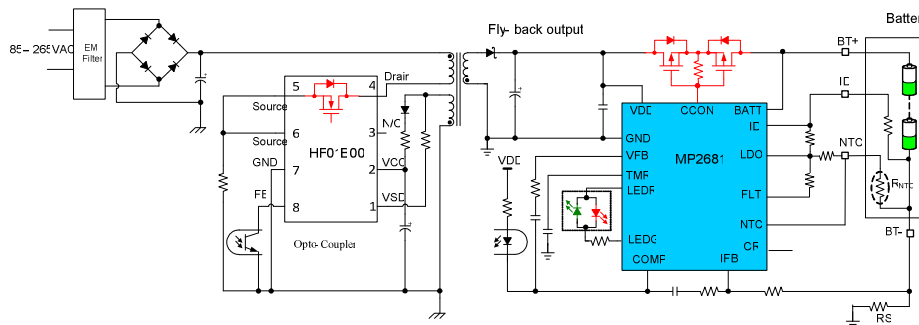

ORDERING INFORMATION

Part Number*	Package	Top Marking
MP2681GS	SOIC16	MP2681

* For Tape & Reel, add suffix -Z (e.g. MP2681GS-Z);

PACKAGE REFERENCE

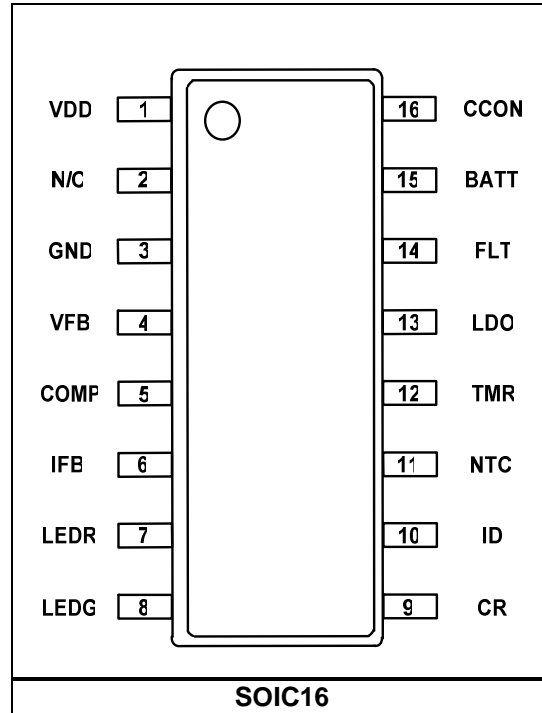

ABSOLUTE MAXIMUM RATINGS ⁽¹⁾

VDD, COMP, BATT to GND	-0.3V to +36V
CCON to GND.....	-0.3V to +36V
All Other Pins.....	-0.3V to +6.5V
Continuous Power Dissipation (T _A =+25°C) ⁽²⁾	1.6W
Junction Temperature.....	150°C
Lead Temperature (Solder).....	260°C
Storage Temperature.....	-65°C to +150°C

Recommended Operating Conditions ⁽³⁾

VDD to GND.....	4.5V to 30V
Operating Junct. Temp. (T _J).....	-40°C to +125°C

Thermal Resistance ⁽⁴⁾	θ_{JA}	θ_{JC}
SOIC16.....	80	35 °C/W

Notes:

- 1) Exceeding these ratings may damage the device.
- 2) The maximum allowable power dissipation is a function of the maximum junction temperature T_J (MAX), the junction-to-ambient thermal resistance θ_{JA} , and the ambient temperature T_A. The maximum allowable continuous power dissipation at any ambient temperature is calculated by P_D (MAX) = (T_J (MAX)-T_A)/ θ_{JA} . Exceeding the maximum allowable power dissipation will cause excessive die temperature, and the regulator will go into thermal shutdown. Internal thermal shutdown circuitry protects the device from permanent damage.
- 3) The device is not guaranteed to function outside of its operating conditions.
- 4) Measured on JESD51-7, 4-layer PCB.

ELECTRICAL CHARACTERISTICS

VDD= 18V, T_A = 25°C, unless otherwise noted.

Parameter	Symbol	Condition	Min	Typ	Max	Units
Input UVLO	V _{IN}		4.1	4.5	4.9	V
Total Supply Current	I _{DD}	VDD = 18V, no load	0.4	0.5	0.6	mA
OPERATIONAL MPLIFIER						
Output Sink Current	I _{comp_sink}	T _A = 25°C, V _{comp} =0.5V		15		mA
Output Leakage Current	I _{COMP_leakage}	T _A = 25°C			0.5	µA
VOLTAGE REFERENCE						
LDO Output Voltage	V _{LDO}	I _{LDO} =0mA to 20mA	4.8	5.0	5.2	V
CHARGE CONTORL						
Pre-charge Threshold	V _{Pre_charge}		2.9	3.0	3.1	V/cell
No-charge Threshold	V _{No_charge}		1.0	1.2	1.4	V/cell
Battery Regulation Voltage	V _{BATT}	T _A = 25°C	4.125	4.15	4.175	V/cell
Recharge Voltage			3.8	3.95	4.0	V/cell
Pre- Charge Current	I _{TC}	V _{BATT} <3.0V/cell		175		mA
Termination Charge Current	I _{BF}	Fast Charging	5	10	15	%I _{CC}
		Slow Charging		30		%I _{CC}
FLT Sink Current		PIN voltage=0.4V		9		mA
LEDR/LEDG Sink Current		PIN voltage=0.4V	8			mA
LEDR/LEDG Source Current		PIN voltage=V _{LDO} -0.3V			20	mA
PROTECTION						
NTC control window	V _{NTC}	R _{NTC} =2.96k, 60°C	21	23	25	%V _{LDO}
		R _{NTC} =28.4k, 0°C	73	74	79	%V _{LDO}
		R _{NTC} =18.3k, 10°C	63	65	70	%V _{LDO}
		R _{NTC} =4.84k, 45°C	30	32	34	%V _{LDO}
Pre-Charge Timer		C _{TMR} =0.1µF,3S1P,4S1P,5S1P		60		min
		C _{TMR} =0.1µF,3S2P,4S2P,5S2P		90		min
Total Charge Time	Fast Charge	C _{TMR} =0.1µF,3S1P,4S1P,5S1P		2		hr
		C _{TMR} =0.1µF,3S2P,4S2P,5S2P		3		hr
	Slow Charge	C _{TMR} =0.1µF,3S1P,4S1P,5S1P		8		hr
		C _{TMR} =0.1µF,3S2P,4S2P,5S2P		12		hr
Timer frequency		C _{TMR} =0.1µF		15		Hz
CCON High Thershold	V _{CCON_H}	VDD>V _{BATT}		VDD-0.6V		V
		V _{BATT} >VDD		V _{BATT} -0.6V		V
CCON Low Thershold	V _{CCON_L}			0.3		V

ELECTRICAL CHARACTERISTICS *(continued)*
VDD= 18V, T_A = 25°C, unless otherwise noted.

Parameter	Symbol	Condition	Min	Typ	Max	Units
CCON Rise Time	t _{r_CCON}	V _{CCON} : 10% to 90% C _{CCON} =10nF		435	500	μs
CCON Fall Time	t _{f_CCON}	V _{CCON} : 90% to 10% C _{CCON} =10nF		50	100	μs
CR High logic	V _{CRH}	Fast Charge	2.5			V
CR Low logic	V _{CRL}	Slow Charge			0.4	V
Thermal Shutdown ⁽⁵⁾	T _{SHTDWN}			150		°C

Notes:

(5). Guaranteed by design

TYPICAL PERFORMANCE CHARACTERISTICS

VDD = 18V, T_A = 25°C, unless otherwise noted.

Battery Charge Curve

5 Cell, I_{CHG} = 4A

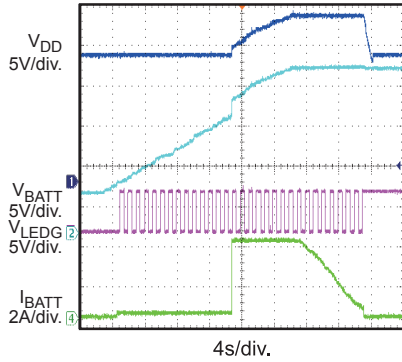

Auto-Recharge

5 Cell, I_{CHG} = 4A

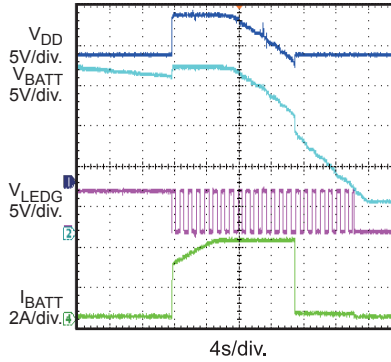

Pre-Charge Steady State

V_{BATT} = 7V

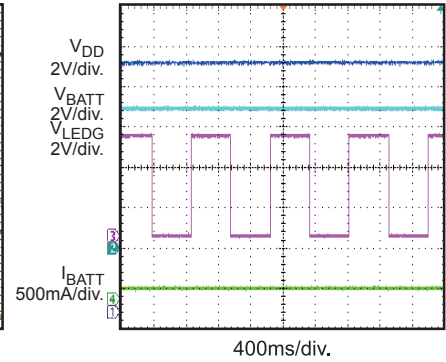

CC-Charge Steady State

V_{BATT} = 15V

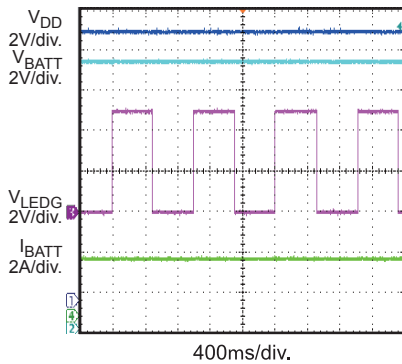

CV-Charge Steady State

V_{BATT} = 16.6V

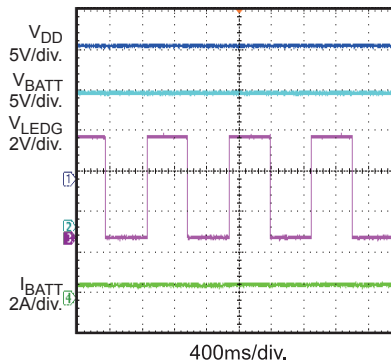

Charge Full

V_{BATT} = 16.6V

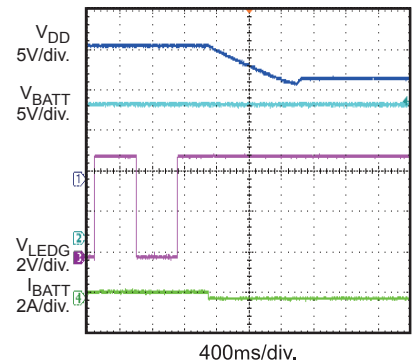

Auto-Recharge

V_{BATT} = 15.5V

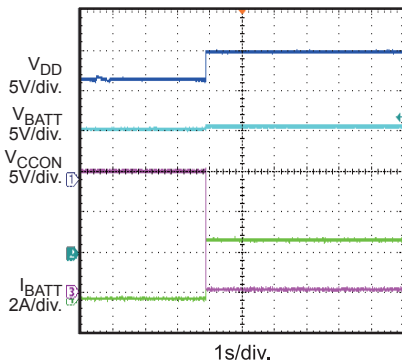

AC-IN Power ON

3 Cell, V_{BATT} = 6V

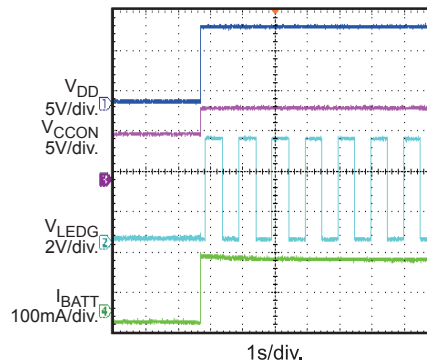

AC-IN Power ON

V_{BATT} = 15V

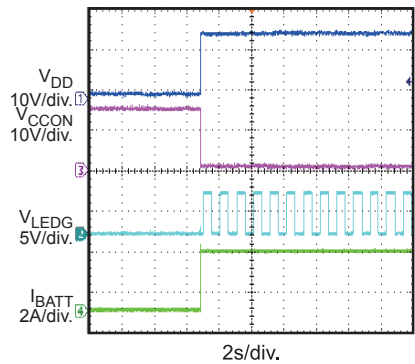

TYPICAL PERFORMANCE CHARACTERISTICS *(continued)*

 VDD = 18V, T_A = 25°C, unless otherwise noted.

AC-IN Power OFF

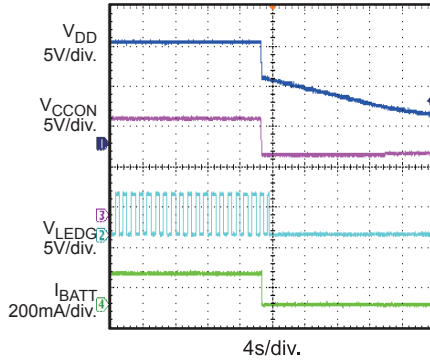
 V_{BATT} = 8V

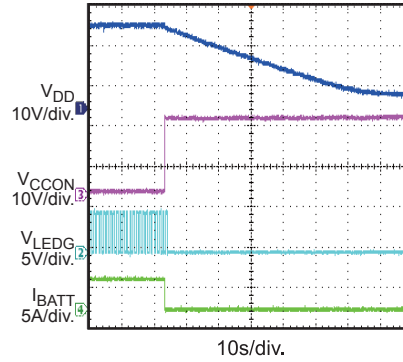
AC-IN Power OFF

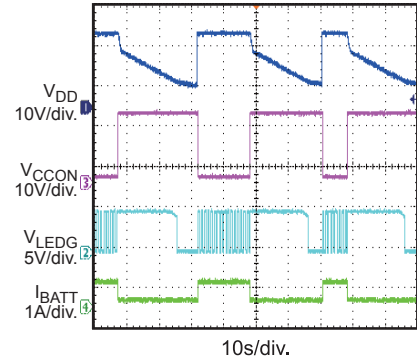
 5 Cell, V_{BATT} = 19V, I_{CHG} = 4A

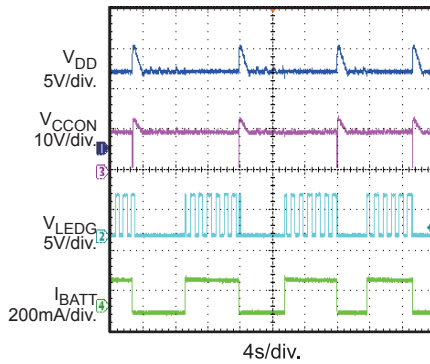
AC-IN Power ON/ OFF

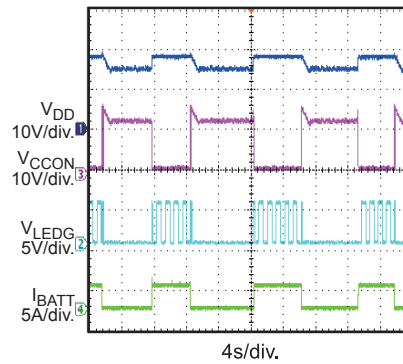
 V_{BATT} = 16.6V

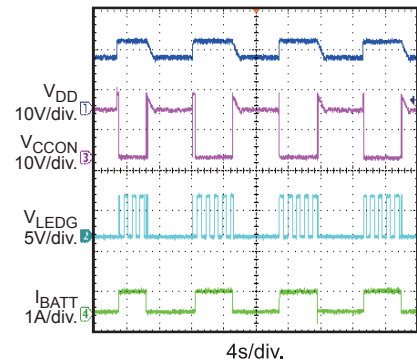
Battery Insertion/ Removal

 3 Cell, V_{BATT} = 6V

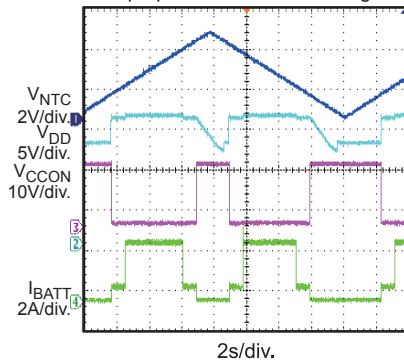
Battery Insertion/ Removal

 V_{BATT} = 15V

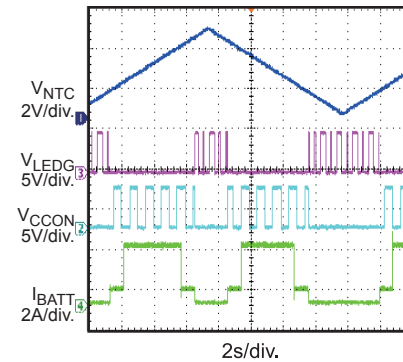
Battery Insertion/ Removal

 V_{BATT} = 16.6V

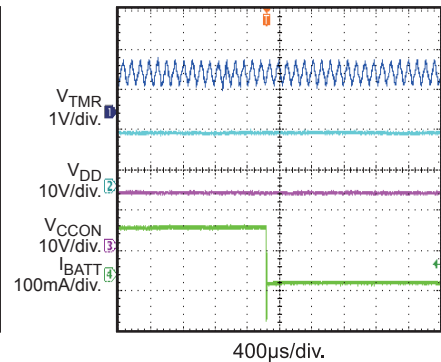
NTC Fault Control

 V_{BATT} = 15.5V,
Ramp up and down NTC voltage

NTC Fault Indication

 V_{BATT} = 15.5V

Timer Out Protection

 C_{TMR} = 150pF, V_{BATT} = 10V

TYPICAL PERFORMANCE CHARACTERISTICS *(continued)*

VDD = 18V, TA = 25°C, unless otherwise noted.

Timer Out Protection

CTMR = 150pF, VBATT = 15V

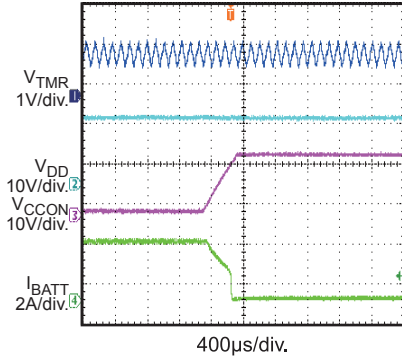

Timer Out Indication

CTMR = 150pF, VBATT = 15.5V

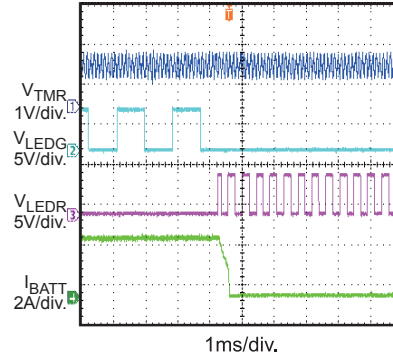

ID Short Protection

VBATT = 10V

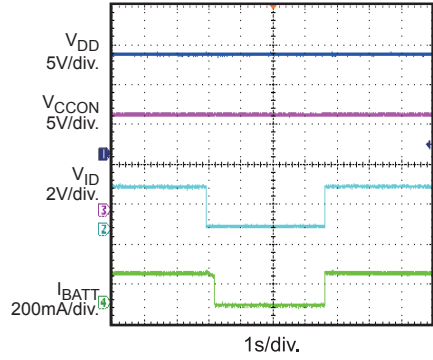

ID Short Protection

VBATT = 15V

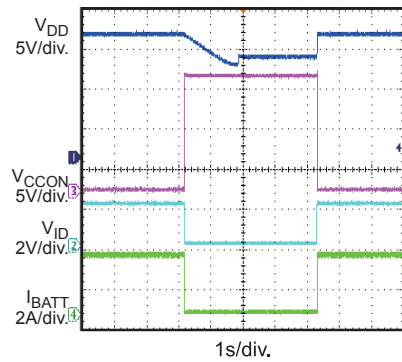

ID Short Indication

VBATT = 15V

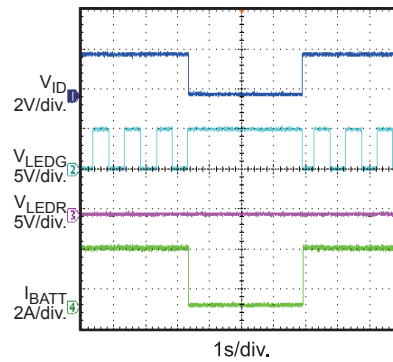

ID Open Protection

VBATT = 10V

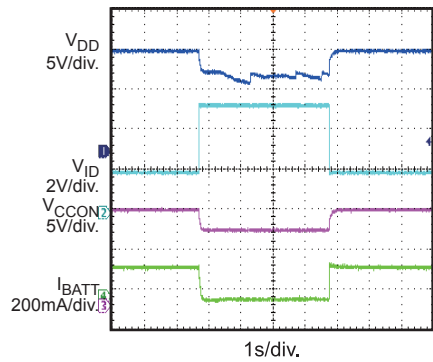

NTC Fault Control

VBATT = 15.5V,
Ramp up and down NTC voltage

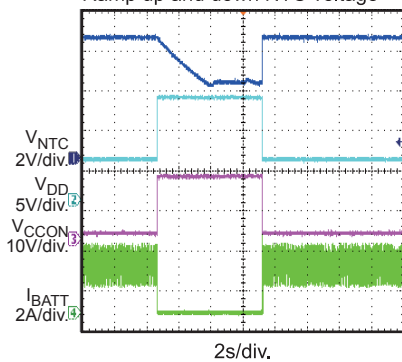

NTC Fault Indication

VBATT = 15.5V

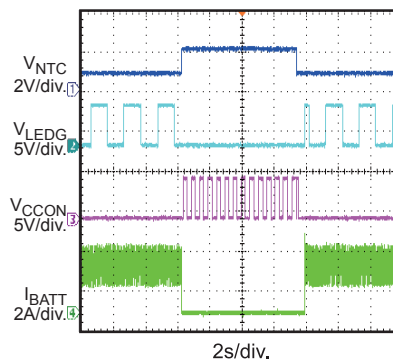

Timer Out Protection

CTMR = 150pF, VBATT = 10V

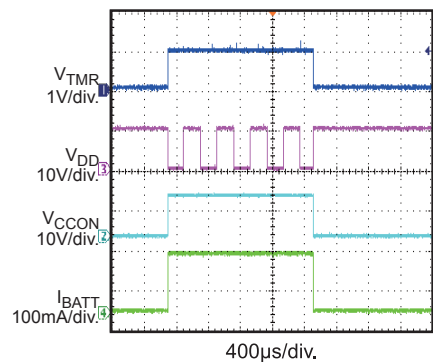

PIN FUNCTIONS

Package Pin #	Name	Description
1	VDD	Power Supply Input. Bypass VDD to GND with a capacitor, at least 4.7 μ F.
2	NC	No Connected.
3	GND	Ground
4	VFB	Voltage feedback pin. Connect this pin to the compensation of the voltage regulation loop externally.
5	COMP	Output pin common to voltage regulation and current limitation loops. Connect to the cathode of the opto-coupler.
6	IFB	Current feedback. Connect to current sense resistor.
7	LEDR	Charging status Indicator. (See table 3 for indication)
8	LEDG	Charging status Indicator. (See table 3 for indication)
9	CR	Charge Rate Setting Pin. Pull it to logic high to set the charger in fast charge or logic low to set the charger in slow charge. Floating this pin sets the charger in fast charge as default setting.
10	ID	Connect to the ID resistor output pin of the battery pack. This pin is used to detect the battery type.
11	NTC	Battery temperature monitoring pin. Please see Fig 2 for proper connection.
12	TMR	Timer setting pin. Connect a capacitor from this pin to GND to set the oscillator cycle. The Timer setting period changes according to oscillation cycle. Short this pin to ground to disable the timer.
13	LDO	LDO output for pulling high voltage of NTC, FLT and ID pins.
14	FLT	Drain output pin to detect a charge fault condition. It is pulled low when any fault happens. Connect this pin to the battery pack pin if available. Pull FLT high to LDO pin through a resistor.
15	BATT	Battery Sense Voltage input.
16	CCON	External charge on/off control MOSFET gate control pin. This pin cuts off the charge path when any fault happens or protection is triggered.

OPERATION

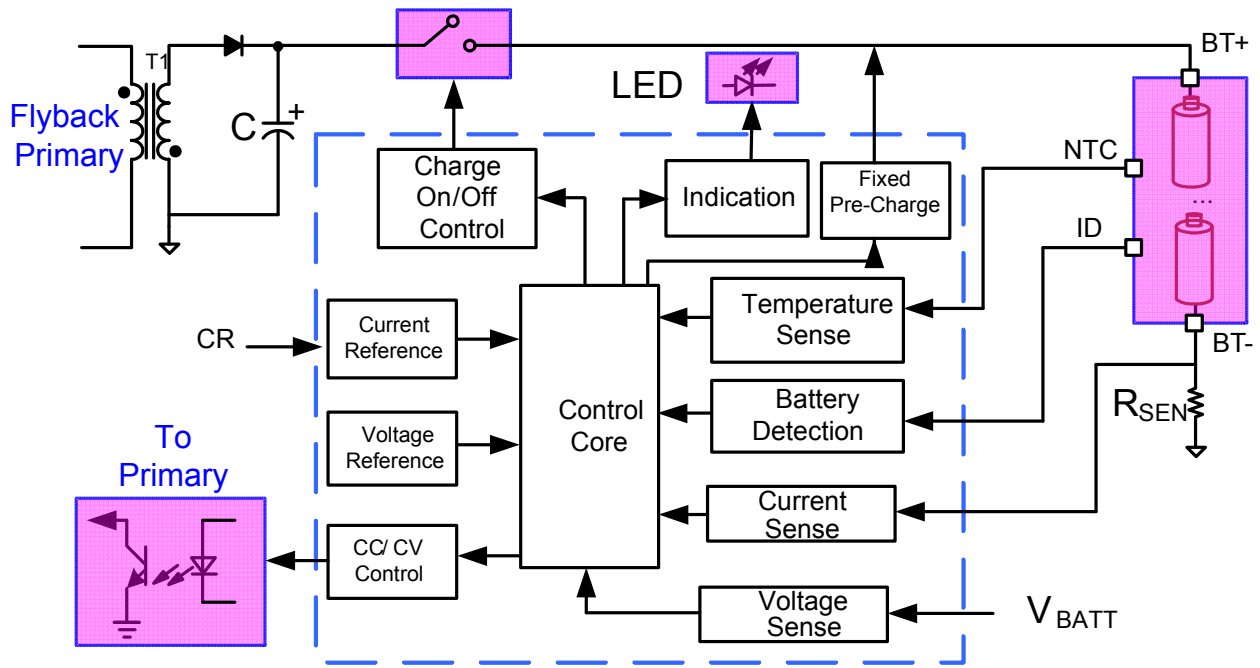

Figure 1 — Functional Block Diagram

Charge Voltage Setting

The MP2681 can support 6 different types of battery configurations: 3S1P, 3S2P, 4S1P, 4S2P, 5S1P and 5S2P using a dedicated ID resistor pin. When a battery pack configuration is detected through the ID resistor, the charge voltage is automatically set internally, different battery pack implementations require different ID resistor values. The ID pin of the MP2681 is connected to the ID resistor in the battery pack and pulled up to the LDO pin by a 20kΩ resistor as shown in Figure 2. Every battery configuration will have a pre-set V_{ID} value. As such, the MP2681 will compare V_{ID} to its internal reference to figure out the inserted battery configuration. As the battery changes among the six pre-set configurations the MP2681 detects such condition, and automatically modifies the resistor divider from VDD pin as shown in Figure 3. Charge current as well as other charge parameters will change accordingly.

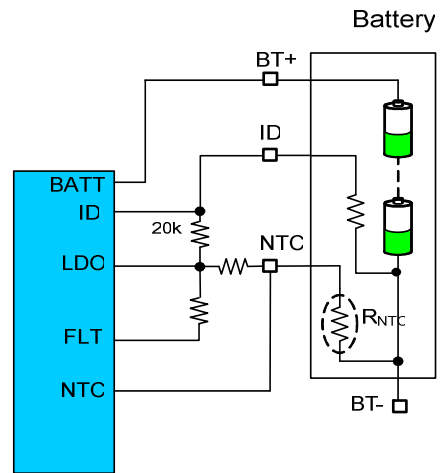

Figure 2 — Battery Pack Pin Connection

Additionally, if the battery pack does not have an ID resistor, the charge termination voltage can be configured by setting a dedicated voltage to the ID pin according to the six pre-set V_{ID} values representing each battery configuration

Table 1 is a summary of all the charge voltage setting for the MP2681. The real ID voltage threshold for every battery

pack is about $\pm 65\text{mV}$ wider than the ones listed in the table taking in consideration reference variations, comparator offsets and hysteresis.

Table1: Charge Voltage Setting Summary

ID resistor	Detect Voltage	Operation Mode	Battery Spec	Output Voltage
Float	$V_{ID} > 4.145\text{V}$	Sleep Mode	Unknown	3.2V/cell
73.2k	$3.534\text{V} < V_{ID} < 4.145\text{V}$	Automatic Mode	3S1P	12.45V
28.7k	$2.54\text{V} < V_{ID} < 3.25\text{V}$		3S2P	12.45V
13k	$1.685\text{V} < V_{ID} < 2.195\text{V}$		4S1P	16.6V
7.87k	$1.185\text{V} < V_{ID} < 1.605\text{V}$		4S2P	16.6V
3.9k	$0.64\text{V} < V_{ID} < 0.965\text{V}$		5S1P	20.75V
1.62k	$0.265\text{V} < V_{ID} < 0.475\text{V}$		5S2P	20.75V
Short	$V_{ID} < 0.265\text{V}$	Sleep Mode	Unknown	3.2V/cell

If the ID pin voltage is detected out of range based on the values specified in Table 1 possibly caused by the insertion of a wrong battery pack configuration, the MP2681 will detect this fault condition and cutoff the external MOSFET to stop charging and protect the battery. Under this condition the output voltage is set to a default value of 3.2V/cell and the MP2681 enters sleep mode. The MP2681 also provides a fault indication.

The MP2681 compares the VFB voltage to its internal voltage reference in order to keep voltage regulation. If this voltage is higher than 2.075V, the output of the voltage loop operational amplifier will decrease. The opto-coupler current increases reducing the output voltage of the PWM controller.

Figure 3 shows the CC and CV control circuit.

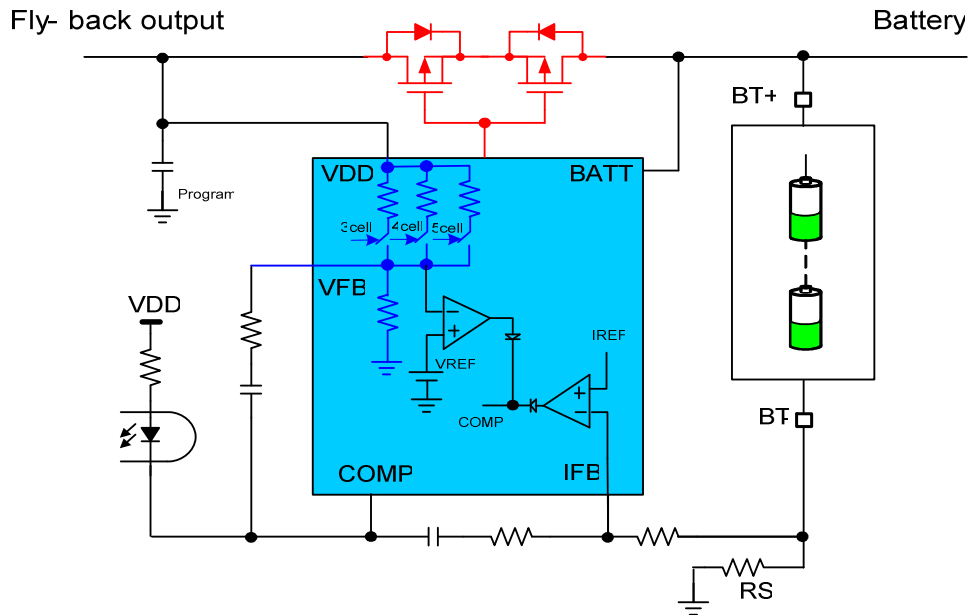

Figure 3 — CC/CV Control Circuit of MP2681

Charge Current Setting

The current limitation (I_{CHG}) is performed by sensing the voltage across the sense resistor R_S and comparing it to charge current reference V_{IREF} , when the sense voltage on R_S is higher than the reference voltage V_{IREF} , the output of the current limitation loop operational amplifier decreases. The opto-coupler current increases and tends to reduce the output voltage by the way of the PWM controller as shown in Figure 3.

Choose the sense resistor R_S according to the charge current and the following formula.

$$R_S = \frac{V_{IREF}}{I_{CHG}}$$

The charge current reference is controlled by the CR pin to set the charge rate. If CR pin is logic high, V_{IREF} is fixed at 0.16V internally, and the charge current can be programmed only by changing the sense resistor. Pull CR pin low to set the IC in slow charge, V_{IREF} is set to 0.016V to decrease the charge current without changing the external resistor. With the CR pin, the MP2681 can set the charger in fast or slow charge automatically. Floating the CR pin sets the charger in fast charge as per default setting.

To avoid large currents flowing into the battery, the MP2681 implements an over current protection scheme. When the voltage on IFB pin is detected over 500mV, the MP2681 will cut-off the charge current path to the battery.

Pre-charge Mode

Before the charging cycle starts, the MP2681 sense the battery voltage.

If the battery voltage is lower than 1.0V/cell the MP2681 will act as there is a dead battery and it never starts charging. If the battery voltage is lower than 3.0V/cell, the MP2681 will go into pre-charge mode. The external MOSFET is off in this mode, and the output voltage control of the fly-back is set at a default value of 3.2V/cell. The MP2681 acts as constant current source, supplying a constant 150mA current to charge the battery pack through the BATT pin.

This period will last until the battery voltage increases over 3.0V/cell threshold or during time out. A fixed timer will start when pre-charge mode starts. The MP2681 sets the time period for pre-charge at 60min for one parallel low capacity battery, and 90min for two parallel low capacity batteries with 0.1uF timer capacitor C_{TMR} . Changing the capacitor value will change the time period only during charge mode but not during the pre-charge mode

The pre-charge mode ensures to safely charge any deeply discharge battery.

Charge Cycle (Mode Change: CC → CV)

At the end of the pre-charge cycle and when the battery voltage is at least equal to 3.0V/cell, the external MOSFET is turned on and the MP2681 will enter constant current charge mode. This mode of operation will stay as long as the battery voltage will not cross the pre-set charge full threshold.

After the battery voltage is over 3.0V/cell, the IC begins to charge at the programmed constant current rate (I_{CHG}). This is referred to the constant current in (CC) mode. Once the output voltage reaches the battery regulation voltage, the charger will operate in constant voltage (CV) mode until the battery is fully charged. During this time, the charge current starts to decrease down to I_{BF} threshold which is usually 10% of the programmed constant current value.

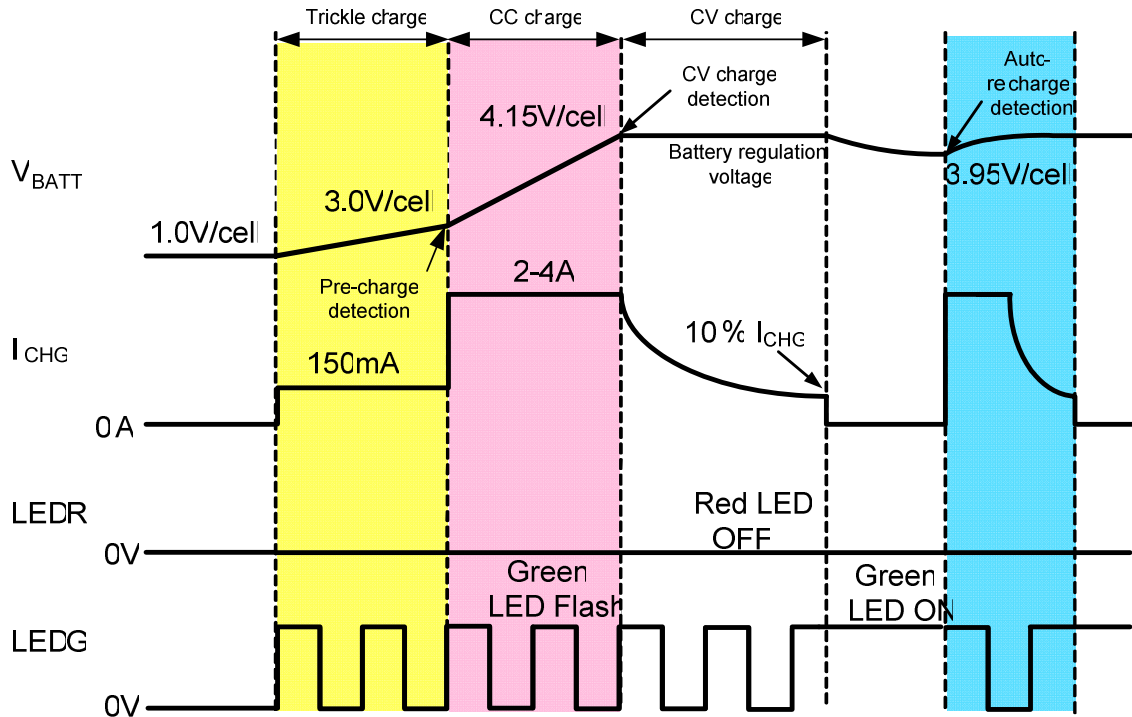

FIGURE 4 — TYPICAL CHARGE PROFILE

Charge Termination

The charge cycle is considered complete when the charge current reaches the programmed termination current threshold I_B . Please refer to Fig 4 for a complete view of the charging cycle and LED's operation.

Automatic Recharge

The MP2681 allows the battery to be automatically recharged when the battery voltage drops below the auto-recharge threshold of 3.95V/cell. The MP2681 will automatically reset the reference voltage to the normal charging value and turn on the CCON driver to restart the charge cycle until the I_{BF} condition is met again.

LDO Output

The MP2681 implements a 5V LDO which provides a pull up voltage for the NTC, ID resistor and FLT detection. It supplies up to 20mA current. When VDD is higher than 5V, the LDO output is regulated at 5V, while if the VDD input voltage is lower than 5V, the FET is fully on and LDO output nearly equals to the input voltage VDD.

Timer Operation

The MP2681 provides a safety timer in case of a defective battery pack.

During pre-charge mode the charge timer is fixed with a set capacity based on the battery specifications. During CC and CV charge mode the timer duration is proportional to the charge rate. The timer will start counting after every time the charger process starts such as initial power-up or automatic recharge. The timer will limit pre-charge time to T1 oscillating cycles on the TMR pin. If the charger stays in pre-charge mode for longer than T1 cycles, the MP2681 will terminate the charging operation by disconnecting the battery from the charger. The output voltage is regulated to the default value. The timer fault indication will also be set by flashing LEDR and keeping LEDG low. After a fault reporting condition, the charger can be re-initiated only by recycling the power supply. The timer limit in the pre-charge mode is fixed and it will not change when the IC is set to slow charge or fast charge mode via the CR pin.

If the charger successfully goes through pre-charge within the allowed time limit, it will start CC charge and then CV charge. If the total charge time exceeds T2 cycles and the battery full has not been reached, the MP2681 will terminate the charger and the CCON output will be pulled high to turn off the switch and stop charge. The timer out fault indication will also be set: flashes LEDR and LEDG low. This function prevents charging a dead battery for prolonged duration. Table 2 shows the Timer for pre-charge and total charge duration limit.

Table 2— Timer Cycles

Spec	T1	T2
3S1P, 4S1P, 5S1P	57600	Fast:115200
		Slow:460800
3S2P,4S2P,5S2P	86400	Fast:172800
		Slow:691200

The TMR pin is used to set the internal oscillator frequency. The timer function can be disabled by shorting TMR pin to ground although this is not recommended.

The Timer frequency according to the TMR capacitor is as below:

$$T(s) = 0.6 \times C(\mu F)$$

Smart Negative Temperature Coefficient (NTC) Protection

The MP2681 continuously monitors the battery temperature by measuring the voltage on the NTC pin, which is generated by a negative temperature coefficient (NTC) thermistor and an external voltage divider. The controller compares this voltage against its internal thresholds to determine if the charging is allowed. As Figure 5 shows, to initiate a charge cycle, the voltage on NTC pin must be within the V_{T1} to V_{T4} thresholds. If the V_{NTC} is outside of this range the controller suspends charge and waits until the battery temperature is back within V_{T1} to V_{T4} range again. During V_{T2} and V_{T3} range, the charge current is usually set at 2C rating corresponding to I_{CHG} set by the user. If the NTC pin voltage is between V_{T1} and V_{T2} the MP2681 will decrease the charge current to $I_{CHG}/4$. When the IC is in pre-charge or slow charge mode, the charge current is set to low and the NTC will not have any effect on the

charge current. Figure 5 shows the charge current setting by the NTC window control.

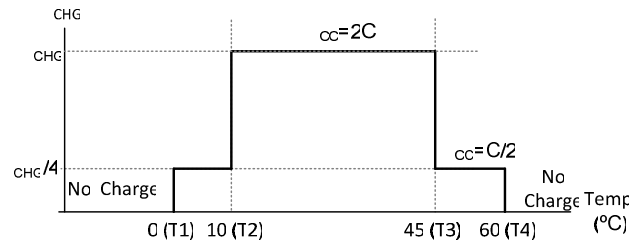

Figure 5 — NTC control window

CCON

The CCON is a driver output pin used to turn on/off the external MOSFET to connect or cutoff the charge path according to the charge condition. If the MP2681 is under normal charge operation, the CCON is pulled low, else if a fault happens, CCON is pulled high to cutoff the charge path.

Status indication

The MP2681 integrates two driver outputs, LEDG and LEDR. Connecting a bi-color back-to-back LED between these two pins can output varieties of indication states to help distinguish each operation, including: charging, charge termination, NTC fault, timer out, ID open, ID out pf range, ID short and power line fault.

Table 3 below summarizes the status of the two indication LEDs under the different charge state based on the LEDR and LEDG outputs as Figure 6 shown.

Table 3- LED Indicator Table

Condition	Red LED	Green LED	CCON
Charging	OFF	Flash	Low
Charging Finish/ID short	OFF	ON	High
NTC Fault	Flash	OFF	High
Timer Fault/ID open/ID out of range	Flash	OFF	High
Power Line Fault	Flash	OFF	High

Power Supply

The MP2681 does not operate when VDD voltage is under 4.5V. The charge starts to work when the output voltage is 200mV higher than battery voltage. The MP2681 also integrates an over voltage protection on VDD to protect the battery. When the power supply is under 4.5V or VBATT+200mV and when the VDD voltage is 100mV/cell over the battery limit value 4.15V/cell the power supply is detected as invalid and the MP2681 will turn off the external power switch to stop charging.

Battery Voltage Sense

BATT pin is used to sense the battery voltage. It is connected to the positive output of the battery pack. The MP2681 detects the battery voltage through this pin to enable the correct charge setting. During start up, after the supply voltage is above 4.5V, the MP2681 will start to detect the battery voltage. If V_{BATT} is lower than 1.0V/cell (dead or no battery) the MP2681 will not start charging. This condition will stay as long as V_{BATT} goes over 1.0V/cell. If the battery voltage is

detected lower than 3.0V/cell, the MP2681 will go into pre-charge mode and a fixed constant current of 150mA will flow from BATT pin to the battery pack to charge the battery. In pre-charge mode the external MOSFET will stay off to cutoff the charge path and the output voltage is set at the default 3.2V/cell. During normal charge operation, if the battery is removed, the MP2681 detects this condition through $V_{BATT} < 1.0V/cell$. The MP2681 will regulate the reference voltage to set the fly-back output to the default value of 3.2V/cell and never start charging until V_{BATT} is higher than 1.0V/cell.

Fault Protection

FLT pin is an open drain output, and it is pulled low when any fault condition is asserted. Connect the FLT pin to the LDO output through a resistor. Under any fault condition including NTC fault, timer out and ID pin fault, the FLT pin is pulled low. Meanwhile, the MP2681 pulls CCON high to cut off the fly-back output from the battery at once and regulates the reference voltage to set the fly-back output to the default 3.2V/cell.

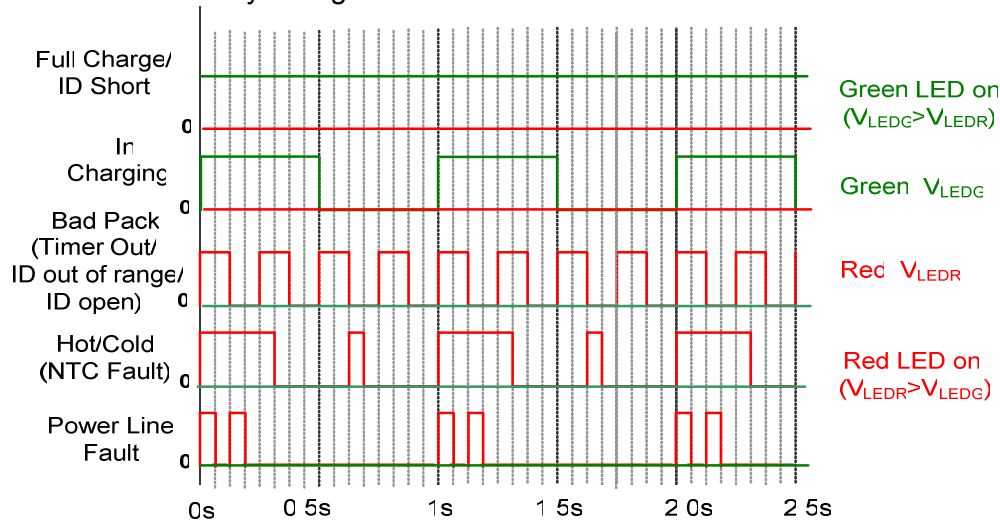
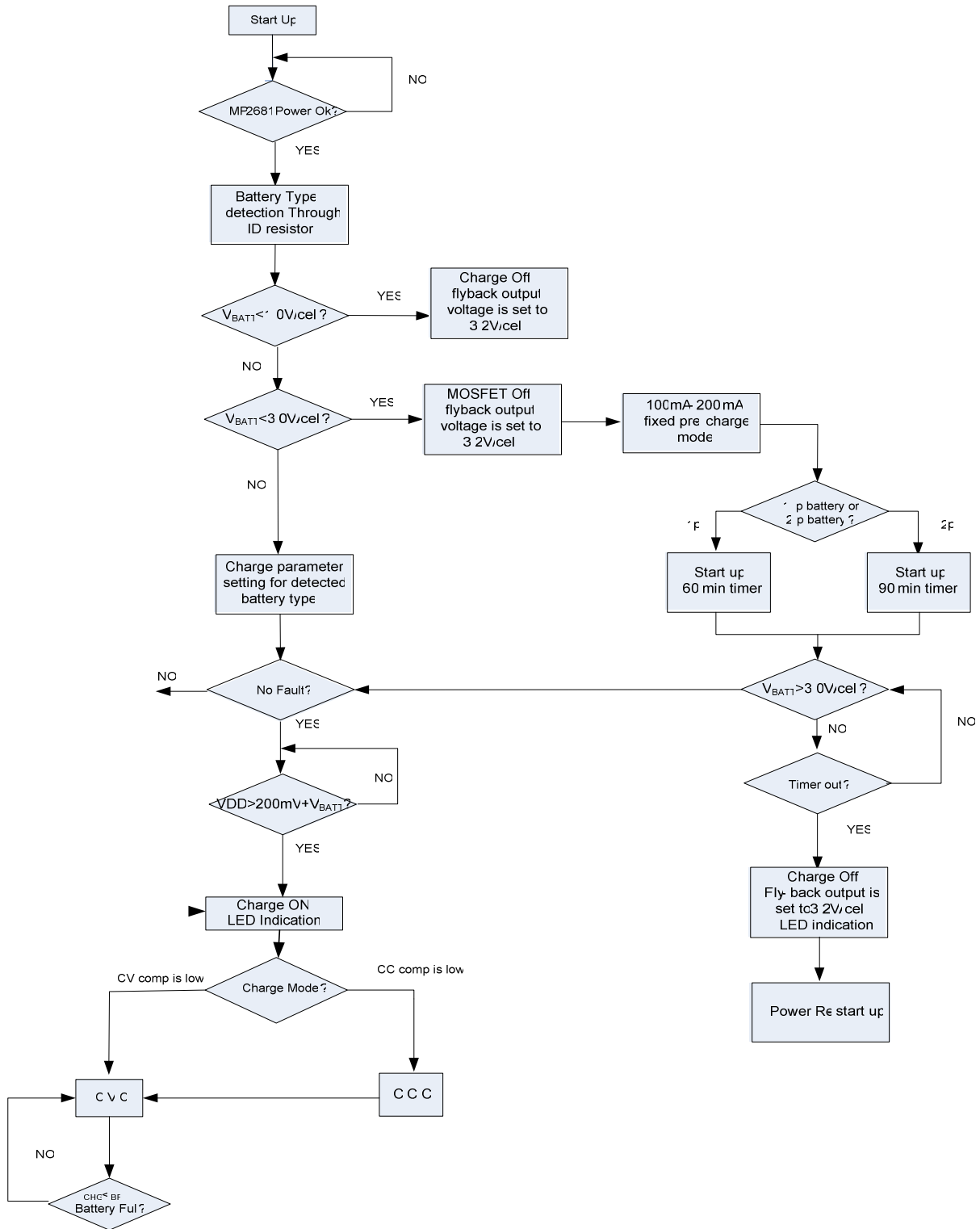

Figure 6 — Schematic plot of the output voltage at LEDG/LEDR pin

CONTROL FLOW CHART



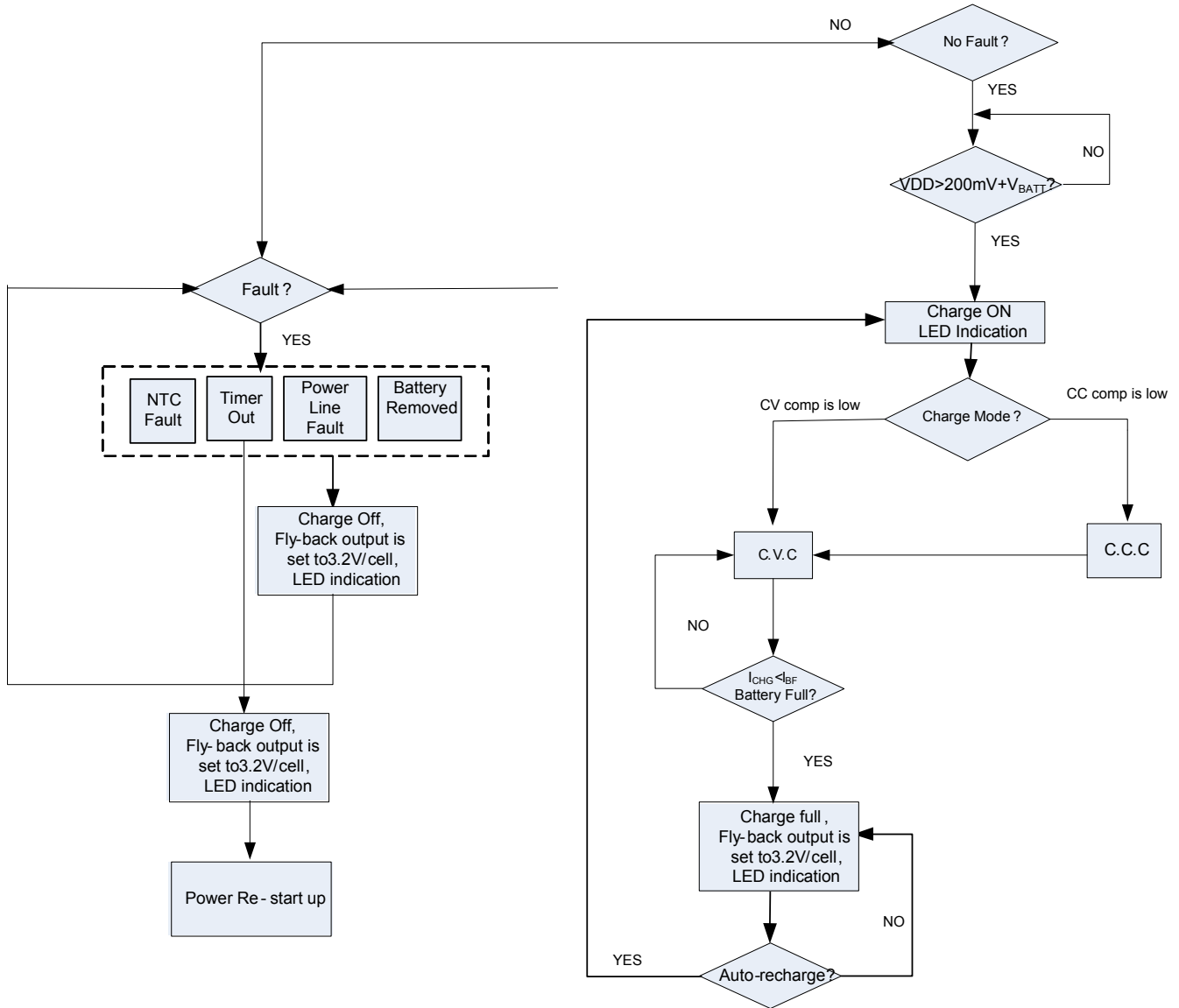

Figure 7 — MP2681 Control Flow Chart

OPERATION WAVEFORM

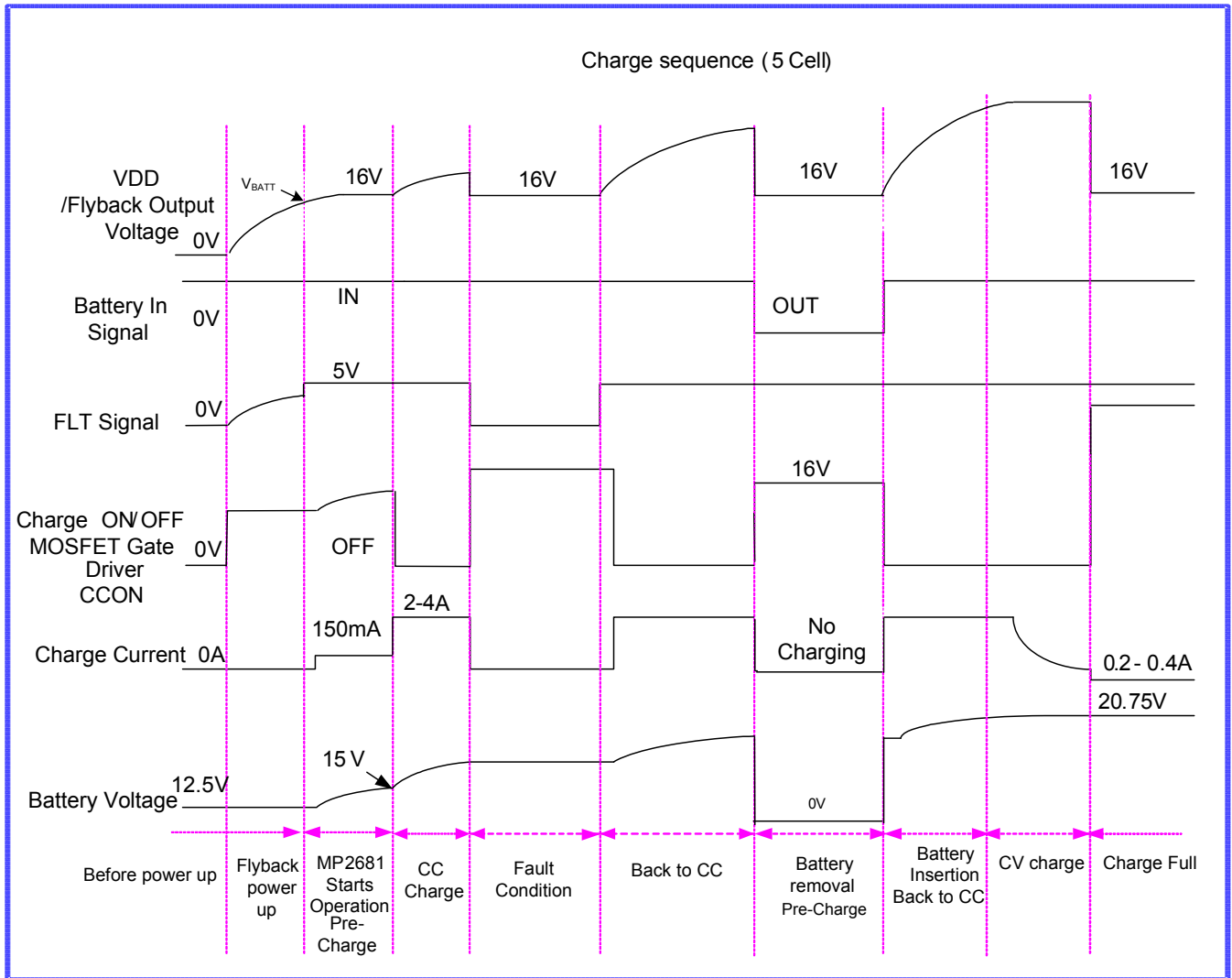

Figure 8 — MP2681 Charge Sequence (5 Cell)

APPLICATION INFORMATION

COMPONENT SELECTION

Setting the VDD Voltage

VDD voltage is regulated based on the battery spec according to the ID resistor.

The relationship between the ID voltage and the VDD voltage is as following table:

Table 4: VDD setting

Setting the charge current

ID Voltage	Battery Spec	VDD Voltage
$V_{ID} > 4.09V$	Unknown	3.2V/cell
$3.6V < V_{ID} < 4.09V$	3S1P	12.45V
$2.66V < V_{ID} < 3.13V$	3S2P	12.45V
$1.74V < V_{ID} < 2.14V$	4S1P	16.6V
$1.24V < V_{ID} < 1.55V$	4S2P	16.6V
$0.7V < V_{ID} < 0.91V$	5S1P	20.75V
$0.32V < V_{ID} < 0.42V$	5S2P	20.75V
$V_{ID} < 0.32V$	Unknown	3.2V/cell

The current limitation (I_{CHG}) is performed by sensing the voltage across the sense resistor R_S and comparing it to charge current reference V_{IREF} , as the following formula

$$R_S = \frac{V_{IREF}}{I_{CHG}} \quad (1)$$

The charge current reference is controlled by the CR pin to set the charge rate. If CR pin is logic high, V_{IREF} is fixed at 0.2V internally. Pull CR pin low to set the charger in slow charge, V_{IREF} is set to 0.02V

Timer Setting

The TMR pin is used to set the internal oscillator frequency, Timer setting formula is as below:

Pre-Charge timer

$$1P: T_{Pre-1P}(s) = 34560 \times C(uF) \quad (2)$$

$$2P: T_{Pre-2P}(s) = 51840 \times C(uF) \quad (3)$$

Total- Charge timer:

Fast Charge:

$$1P: T_{Total-1P-fast}(s) = 69120 \times C(uF) \quad (4)$$

$$2P: T_{Total-2P-fast}(s) = 103680 \times C(uF) \quad (5)$$

Slow Charge:

$$1P: T_{Total-1P-slow}(s) = 276480 \times C(uF) \quad (6)$$

$$2P: T_{Total-2P-slow}(s) = 414720 \times C(uF) \quad (7)$$

Resistor Choose for NTC Sensor

Figure 9 shows an internal resistor divider reference circuit to limit the four temperature threshold at 74%·LDO, 65%·LDO, 32%·LDO and 23%·LDO, respectively. To specify the operation under cold, cool, warm, and hot condition. For a given NTC thermistor, select appropriate R_{T1} and R_{T2} to set the NTC window.

$$\frac{R_{T2} // R_{NTC_Cold}}{R_{T1} + R_{T2} // R_{NTC_Cold}} = \frac{V_{T1}}{LDO} = 74\% \quad (8)$$

$$\frac{R_{T2} // R_{NTC_Cool}}{R_{T1} + R_{T2} // R_{NTC_Cool}} = \frac{V_{T2}}{LDO} = 65\% \quad (9)$$

$$\frac{R_{T2} // R_{NTC_Warm}}{R_{T1} + R_{T2} // R_{NTC_Warm}} = \frac{V_{T3}}{LDO} = 32\% \quad (10)$$

$$\frac{R_{T2} // R_{NTC_Hot}}{R_{T1} + R_{T2} // R_{NTC_Hot}} = \frac{V_{T4}}{LDO} = 23\% \quad (11)$$

R_{NTC_Hot} is the value of the NTC resistor at highest temperature of the required temperature operation range, and R_{NTC_Cold} is the value of the NTC resistor at lowest temperature.

The two resistors, R_{T1} and R_{T2} , allow the high temperature limit and low temperature limit to be programmed independently.

It should satisfy the above 4 equations.

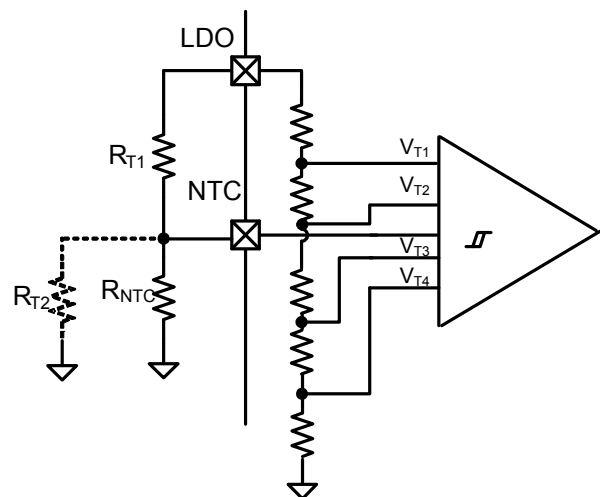

Figure 9—NTC Function Block

PCB Layout Guideline

It is important to pay special attention to the PCB layout to meet specified noise, efficiency and stability requirements. The following design considerations can improve circuit performance:

- 1) Route the power stage adjacent to their grounds. trace lengths in the high-current paths and the current sense resistor trace.
- 2) Keep the power ground away from all small control signals, especially the feedback network.

Place the input capacitor as close as possible to the VDD and PGND pins.

- 3) The IFB and VFB pins are sensitive, please make the compensation components between the FB and COMP close to the pins.

4) The PCB should have a ground plane connected directly to the return of all components through vias (two vias per capacitor for power-stage capacitors, one via per capacitor for small-signal components). It is also recommended to put vias inside the PGND pads for the IC, if possible. A star ground design approach is typically used to keep circuit block currents isolated (high-power/low-power small-signal) which reduces noise-coupling and ground-bounce issues. A single ground plane for this design gives good results. With this small layout and a single ground plane, there is no ground-bounce issue, and having the components segregated minimizes coupling between signals.

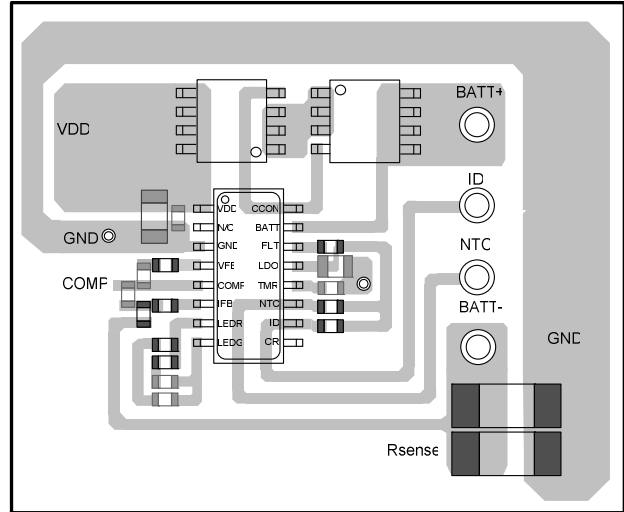

TYPICAL APPLICATION CIRCUITS

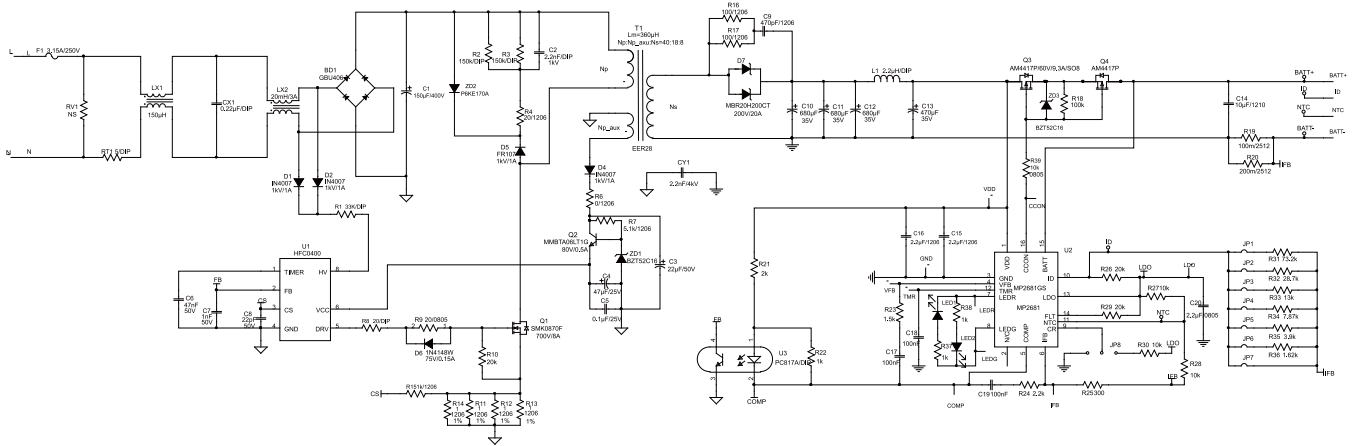

PACKAGE INFORMATION

SOIC-16(TBD)

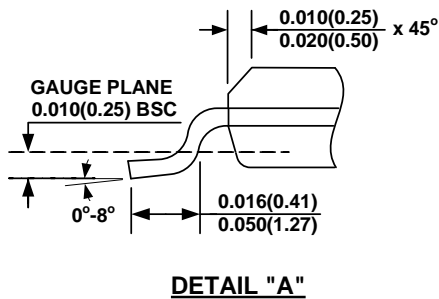
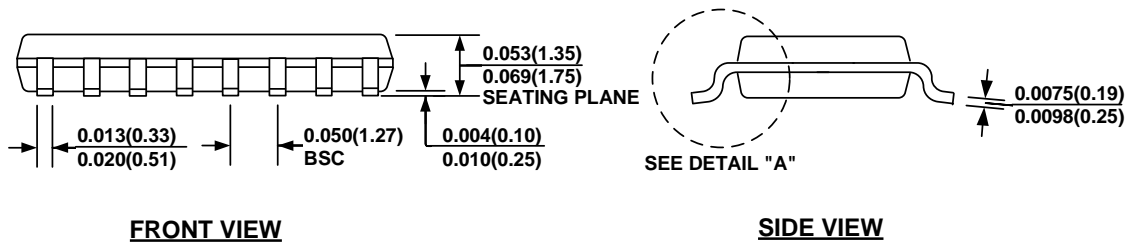
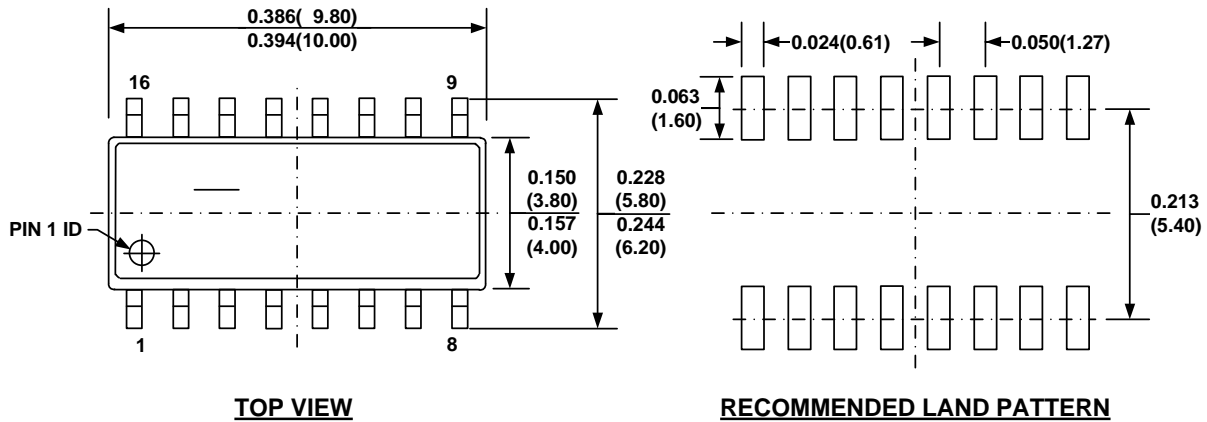

NOTE:

- 1) CONTROL DIMENSION IS IN INCHES. DIMENSION IN BRACKET IS IN MILLIMETERS.
- 2) PACKAGE LENGTH DOES NOT INCLUDE MOLD FLASH, PROTRUSIONS OR GATE BURRS.
- 3) PACKAGE WIDTH DOES NOT INCLUDE INTERLEAD FLASH OR PROTRUSIONS.
- 4) LEAD COPLANARITY (BOTTOM OF LEADS AFTER FORMING) SHALL BE 0.004" INCHES MAX.
- 5) DRAWING CONFORMS TO JEDEC MS-012, VARIATION AC.
- 6) DRAWING IS NOT TO SCALE.

NOTICE: The information in this document is subject to change without notice. Users should warrant and guarantee that third party Intellectual Property rights are not infringed upon when integrating MPS products into any application. MPS will not assume any legal responsibility for any said applications.



Стандарт Электрон Связь

Мы молодая и активно развивающаяся компания в области поставок электронных компонентов. Мы поставляем электронные компоненты отечественного и импортного производства напрямую от производителей и с крупнейших складов мира.

Благодаря сотрудничеству с мировыми поставщиками мы осуществляем комплексные и плановые поставки широчайшего спектра электронных компонентов.

Собственная эффективная логистика и склад в обеспечивает надежную поставку продукции в точно указанные сроки по всей России.

Мы осуществляем техническую поддержку нашим клиентам и предпродажную проверку качества продукции. На все поставляемые продукты мы предоставляем гарантию .

Осуществляем поставки продукции под контролем ВП МО РФ на предприятия военно-промышленного комплекса России , а также работаем в рамках 275 ФЗ с открытием отдельных счетов в уполномоченном банке. Система менеджмента качества компании соответствует требованиям ГОСТ ISO 9001.

Минимальные сроки поставки, гибкие цены, неограниченный ассортимент и индивидуальный подход к клиентам являются основой для выстраивания долгосрочного и эффективного сотрудничества с предприятиями радиоэлектронной промышленности, предприятиями ВПК и научно-исследовательскими институтами России.

С нами вы становитесь еще успешнее!

Наши контакты:

Телефон: +7 812 627 14 35

Электронная почта: sales@st-electron.ru

Адрес: 198099, Санкт-Петербург,
Промышленная ул, дом № 19, литера Н,
помещение 100-Н Офис 331