

Digilent PmodRS232™ Converter Module Board Reference Manual



Revision: June 6, 2012

Note: This document applies to REV B of the board.

215 E Main Suite D | Pullman, WA 99163
(509) 334 6306 Voice and Fax

Overview

The PmodRS232 Converter Module Board (the RS232 module) translates voltage from the logic levels used by Digilent system boards to the RS232 voltage used for serial communications.

The RS232 module creates a two-way I/O exchange by converting RS232 voltage to logic level voltage and converting logic voltage to RS232 voltage. RS-232 voltage levels are -3 to -12V for a logic '1', and +3 to +12 for a logic '0'.

The RS232 module is configured as a data communications equipment (DCE) device. It connects to data terminal equipment (DTE) devices, such as the serial port on a PC, using a straight-through cable.

Features include:

- A Maxim Integrated™ MAX3232CSE RS232 transceiver
- a DB9 connector and 6-pin header
- transmit and receive data functions
- optional RTS and CTS handshaking functions
- small form factor (1.00" x 1.30").

Functional Description

The RS232 module provides two transmit buffers and two receive buffers. A transmit buffer converts a logic-level signal on its input to an RS232 voltage-level signal on its output. A receive buffer converts an RS232 voltage-level signal on its input to a logic-level signal on its output.

The RS232 module can be configured as either a 3-wire DTE serial port (with one transmitter for transmit-data signals, one

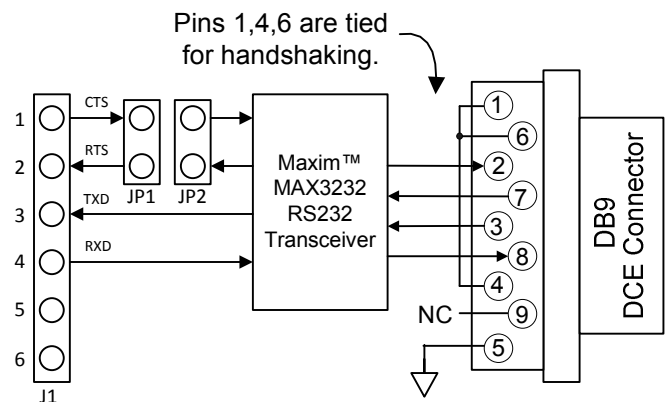
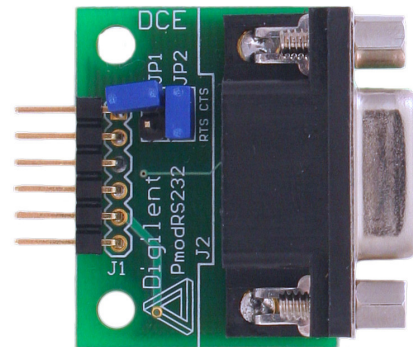

RS232 Module Block Diagram

receiver for receive-data signals, and a signal-ground connection), or as a 5-wire DTE serial port with an additional transmitter and receiver for RTS and CTS handshaking signals, respectively.

The RS232 module is designed to work with either Digilent programmable logic system boards or embedded control boards. Most Digilent system boards (like the Basys, Nexys or Cerebot) have 6-pin connectors that allow the RS232 module to plug directly into the

system board or to connect via a Digilent 6-pin cable.

Some older Digilent boards may need a Digilent Module Interface Board (MIB) and a 6-pin cable to connect to the RS232 module. The MIB plugs into the system board and the cable connects the MIB to the RS232 module.

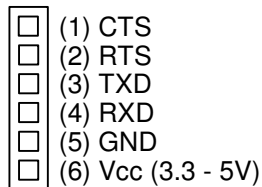

RS232 Module Connector J1

The RS232 module is wired as a DTE device. RS232 signals are named from the perspective of the DCE. The TXD signal carries data from the DCE to the DTE, therefore, the TXD signal on pin 3 is connected to the output of a receiver and should be connected to the receive input of a UART on the system board. Similarly, the RXD signal carries data from the DTE to the DCE and is connected to the input of a transmitter on the RS232 module and should be connected to the output of the UART on the system board.

The CTS signal on pin 1 can be connected to the input of a transmitter and the RTS signal on pin 2 can be connected to the output of a receiver. These connections are made using jumper blocks JP1 and JP2, as described below.

Digilent embedded control boards, like the Cerebot, have one or more connectors with the UART signals configured correctly for direct connection of the RS232 module. On Digilent programmable logic boards like the Basys or Nexys, a UART must be defined in the logic of the FPGA or CPLD and the appropriate signal connections must be defined to connect the UART to appropriate connector pins.

Using Jumper Blocks JP1 and JP2

Jumper blocks JP1 and JP2 are used to configure the RS232 module for either 3-wire

or 5-wire operation. Pins 1 and 2 of JP1 are connected to pins 1 and 2 of connector J1, respectively. Pins 1 and 2 of JP2 are connected to the CTS transmitter and the RTS receiver, respectively.

To configure the RS232 module as a 3-wire DTE with no handshaking, place a shorting block across the two pins of JP2 and ensure there's no shorting block on JP1. This loops RTS back to CTS on the RS232 side of the module and leaves pins 1 and 2 unconnected on J1.

To configure the RS232 module as a 5-wire DTE with RTS/CTS handshaking, place a shorting block across pin 1 of JP1 and pin 1 of JP2, and place another shorting block across pin 2 of JP1 and pin 2 of JP2. This connects the CTS transmitter to pin 1 of J1 and the RTS receiver to pin 2 of J1.



Стандарт Электрон Связь

Мы молодая и активно развивающаяся компания в области поставок электронных компонентов. Мы поставляем электронные компоненты отечественного и импортного производства напрямую от производителей и с крупнейших складов мира.

Благодаря сотрудничеству с мировыми поставщиками мы осуществляем комплексные и плановые поставки широчайшего спектра электронных компонентов.

Собственная эффективная логистика и склад в обеспечивает надежную поставку продукции в точно указанные сроки по всей России.

Мы осуществляем техническую поддержку нашим клиентам и предпродажную проверку качества продукции. На все поставляемые продукты мы предоставляем гарантию .

Осуществляем поставки продукции под контролем ВП МО РФ на предприятия военно-промышленного комплекса России , а также работаем в рамках 275 ФЗ с открытием отдельных счетов в уполномоченном банке. Система менеджмента качества компании соответствует требованиям ГОСТ ISO 9001.

Минимальные сроки поставки, гибкие цены, неограниченный ассортимент и индивидуальный подход к клиентам являются основой для выстраивания долгосрочного и эффективного сотрудничества с предприятиями радиоэлектронной промышленности, предприятиями ВПК и научно-исследовательскими институтами России.

С нами вы становитесь еще успешнее!

Наши контакты:

Телефон: +7 812 627 14 35

Электронная почта: sales@st-electron.ru

Адрес: 198099, Санкт-Петербург,
Промышленная ул, дом № 19, литера Н,
помещение 100-Н Офис 331