

32-Bit

Microcontroller

TriBoard TC1728

Hardware: TriBoard-TC1728 V1.0

Hardware Manual

User's Manual

V 1.0 2011-02

Microcontrollers

Edition 2011-02

**Published by
Infineon Technologies AG
81726 Munich, Germany**

**© 2011 Infineon Technologies AG
All Rights Reserved.**

Legal Disclaimer

The information given in this document shall in no event be regarded as a guarantee of conditions or characteristics. With respect to any examples or hints given herein, any typical values stated herein and/or any information regarding the application of the device, Infineon Technologies hereby disclaims any and all warranties and liabilities of any kind, including without limitation, warranties of non-infringement of intellectual property rights of any third party.

Information

For further information on technology, delivery terms and conditions and prices, please contact the nearest Infineon Technologies Office (www.infineon.com).

Warnings

Due to technical requirements, components may contain dangerous substances. For information on the types in question, please contact the nearest Infineon Technologies Office.

Infineon Technologies components may be used in life-support devices or systems only with the express written approval of Infineon Technologies, if a failure of such components can reasonably be expected to cause the failure of that life-support device or system or to affect the safety or effectiveness of that device or system. Life support devices or systems are intended to be implanted in the human body or to support and/or maintain and sustain and/or protect human life. If they fail, it is reasonable to assume that the health of the user or other persons may be endangered.

32-Bit

Microcontroller

TriBoard TC1728

Hardware: TriBoard-TC1728 V1.0



User's Manual

V 1.0 2011-02

TriBoard TC1728 User's Manual

Revision History: V 1.0 2011-02

Previous Versions: no

Page	Subjects (major changes since last revision)
–	this is the first release
–	
–	

Trademarks

TriCore® is a trademark of Infineon Technologies AG.

We Listen to Your Comments

Any information within this document that you feel is wrong, unclear or missing at all? Your feedback will help us to continuously improve the quality of this document. Please send your proposal (including a reference to this document) to:

mcdocu.comments@infineon.com



Table of Contents

1	Introduction	1-1
2	TriBoard Features	2-1
2.1	Summary of Features	2-1
2.2	Block Diagram	2-3
2.3	Placement	2-4
3	TriBoard Information	3-1
3.1	Power Supply	3-1
3.2	LEDs	3-1
3.3	Clock	3-1
3.4	USB Connector	3-2
3.4.1	Serial Connection to PC	3-2
3.4.2	miniWiggler JDS	3-2
3.5	FlexRay	3-3
3.6	Serial Eeprom	3-3
3.7	MultiCAN	3-3
3.8	Safety option with SAK-CIC61508 (optional)	3-3
3.9	Other peripherals	3-3
3.10	Toggle LED's	3-4
3.11	Debug System	3-4
3.11.1	OCDS1	3-4
3.11.2	DAP	3-4
4	TriBoard Configuration	4-1
4.1	HW Boot Configuration TC1728	4-1
4.2	Assembly Options	4-3
5	TriBoard Software	5-1
5.1	Requirements	5-1
5.2	Software Overview	5-1
5.3	Software Installation	5-1
6	Signal Description	6-1
7	Connector Pin Assignment	7-1
7.1	TC1728 Connector / Top View	7-2
7.2	Power connector pinout	7-4
7.3	USB connector pinout	7-4
7.4	Flexray Pinout	7-4
7.5	CAN connector pinout	7-5
7.6	OCDS connector pinout	7-5
7.7	DAP connector pinout	7-5

8	Schematic and Layout	8-1
8.1	Schematic	8-1
8.2	Layout	8-10
8.3	Layout with Dimensioning	8-12

List of Figures

Figure 2-1	TriBoard Block Schematic	2-3
Figure 2-2	TriBoard TC1728 V1.0 Placement	2-4
Figure 3-1	Clock socket usage (XT301)	3-2
Figure 4-1	HW Configuration TC1728 DIP-Switch	4-1
Figure 4-2	Location of general optional resistors on Top Side	4-4
Figure 4-3	Location of general optional resistors on Bottom Side.	4-4
Figure 4-4	Location of peripheral resistors on Top Side	4-5
Figure 4-5	Location of peripheral resistors on Bottom Side	4-6
Figure 4-6	Location of resistors for safety device on Bottom Side	4-7
Figure 7-1	Connector for TC1728 - Pinout (Part I, Top View)	7-2
Figure 7-2	Connector for TC1728 - Pinout (Part II, Top View)	7-3
Figure 7-3	Power connector pinout	7-4
Figure 7-4	USB connector Pinout	7-4
Figure 7-5	Flexray Pinout (SUBD-9 Plug)	7-4
Figure 7-6	CAN connector pinout (IDC10)	7-5
Figure 7-7	OCDS connector pinout (IDC16)	7-5
Figure 7-8	DAP connector pinout (FTSH10)	7-5
Figure 8-1	Schematic - Project	8-2
Figure 8-2	Schematic - Config, Clock, JTAG and CIC61508	8-3
Figure 8-3	Schematic - Flexray, CAN and Eeprom	8-4
Figure 8-4	Schematic - miniWiggler JDS, DAP and ETK	8-5
Figure 8-5	Schematic - GPTA, MSC, MLI and ADC	8-6
Figure 8-6	Schematic - Power Supply	8-7
Figure 8-7	Schematic - Connectors (Plug)	8-8
Figure 8-8	Schematic - Connectors (Socket)	8-9
Figure 8-9	Component Plot Top Layer	8-10
Figure 8-10	Component Plot Bottom Layer	8-11
Figure 8-11	Dimensioning (mil)	8-12
Figure 8-12	Dimensioning (mm)	8-13



List of Tables

Table 4-1	User Startup Modes for TC1728	4-1
Table 4-2	General optional resistors	4-3
Table 4-3	Resistors for peripherals	4-5
Table 4-4	Resistors for safety device	4-6
Table 6-1	Power Signals	6-1
Table 6-2	Reset Signals	6-1
Table 6-3	Interrupt Signals	6-1
Table 6-4	Clock Signals	6-2
Table 6-5	Debug Signals	6-2
Table 6-6	Peripheral Signals	6-2
Table 6-7	Safety device Signals	6-4

1 Introduction

We congratulate you on your purchase of the TriCore Evaluation Board. This kit is a versatile tool, providing quick access to the capabilities of TriCore's powerful architecture.

Applications can be developed easily. The Evaluation Board is equipped with a variety of memories and peripherals for connection to the environment. There is also an interface for the On Chip Debugging Features (OCDS1 and DAP). The kit also includes several sets of development tools, which are stored on the included Evaluation Board CD-ROM.

The Evaluation Board allows easily the development of TriCore applications with the corresponding tools.

Subsequently, the applications can be downloaded and can be tested with the powerful debugger software.

This TriBoard Hardware Manual familiarizes you with the TriCore Evaluation Board and guides you through the initial configuration of the TriBoard.

For detailed technical information about the TC1728 please refer to the User Manual of the device.



2 TriBoard Features

2.1 Summary of Features

- Infineon's TC1728 Controller in LQFP176 Package
- FlexRay Transceivers
- Safety device (optional)
- High Speed CAN Transceivers
- USB to UART bridge
- Crystal 20MHz (default), Oscillator or External Clock
- USB miniWiggler JDS for easy debugging
- 8 Low Power Status LEDs
- 8-DIP switches for configuration
- access to all pins of controller
- 100mm x 160mm (EURO-Board)

Connectors

The TC1728 TriBoard offers a wide variety of connectors:

- Standard power connector
- USB connector for ASC Interface (ASC0) and miniWiggler
- 16-pin header for JTAG interface (OCDS)
- 10-pin header for DAP
- 2 x 10pin (2x5) Header for CAN High Speed Transceiver (CAN0 and CAN1)
- 2 x SUB-D9 Plug connector for FlexRay
- four 80-pin connectors (male) + four 80-pin connectors (female) with all I/O signals
- optional ETK connector

Components

- Infineon's Next generation micro controller supply TLE 7368-3E
- Three LEDs to validate power supply (5Volt / 3,3 Volt / 1,3 Volt)
- LED indicating /HDRST (ESR0) active state
- LED indicating activ miniWiggler JDS
- LED switched via DAS software
- 2x FlexRay Transceiver AS8221(AMS) or TJA1080 (NXP)
- 2 x Infineon's High Speed CAN-Transceiver TLE 6250 GV33
- Infineon's Safety Device SAK-CIC61508 (optional)
- USB to UART bridge FT2232HL (FTDI)
- SPI eeprom (Atmel)
- 8 general purpose LEDs
- Reset switch
- 8-pin Dip switch

Zero Ohm Bridges

Zero Ohm resistors give the flexibility to configure the systems functionality

2.2 Block Diagram

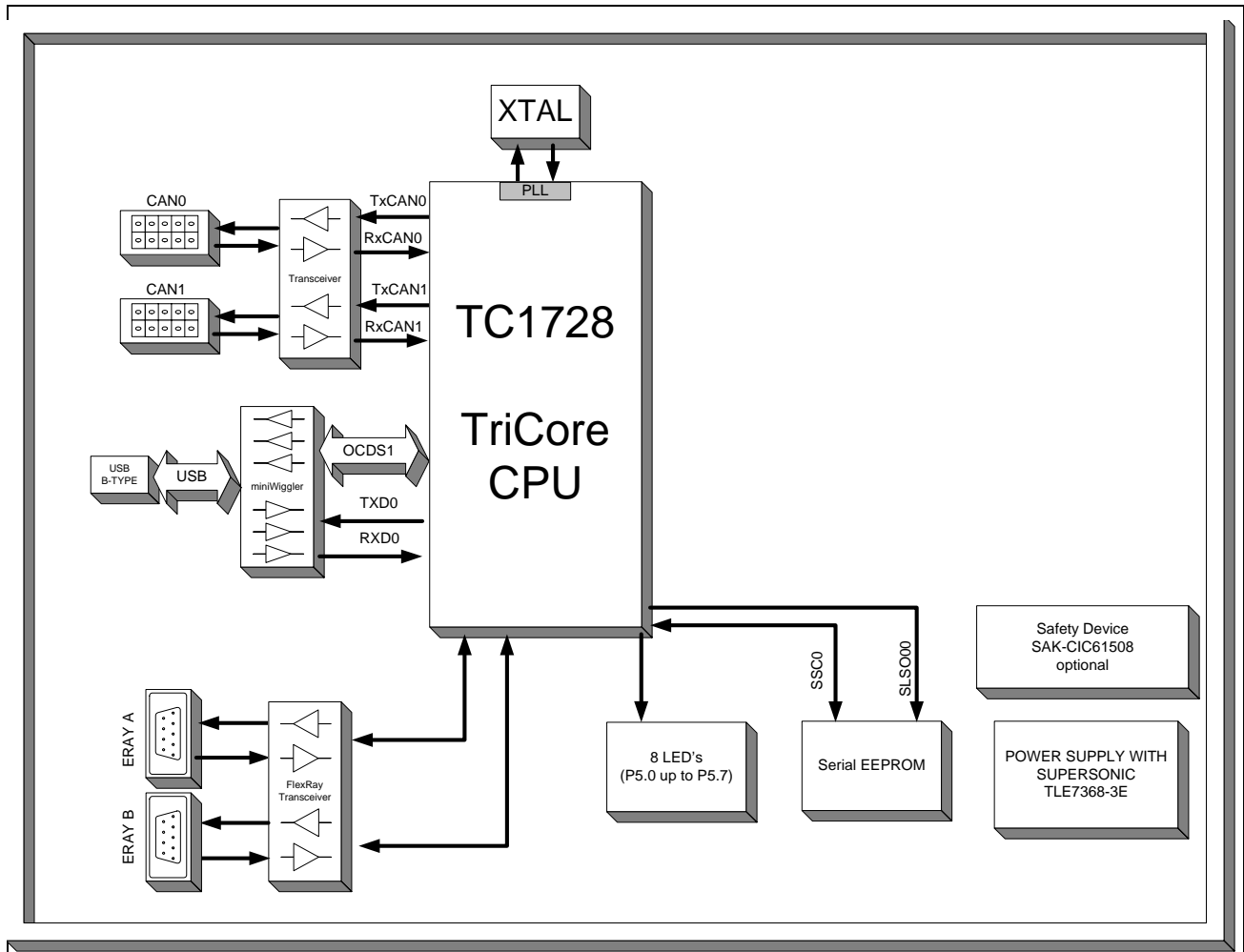

Figure 2-1 TriBoard Block Schematic

2.3 Placement

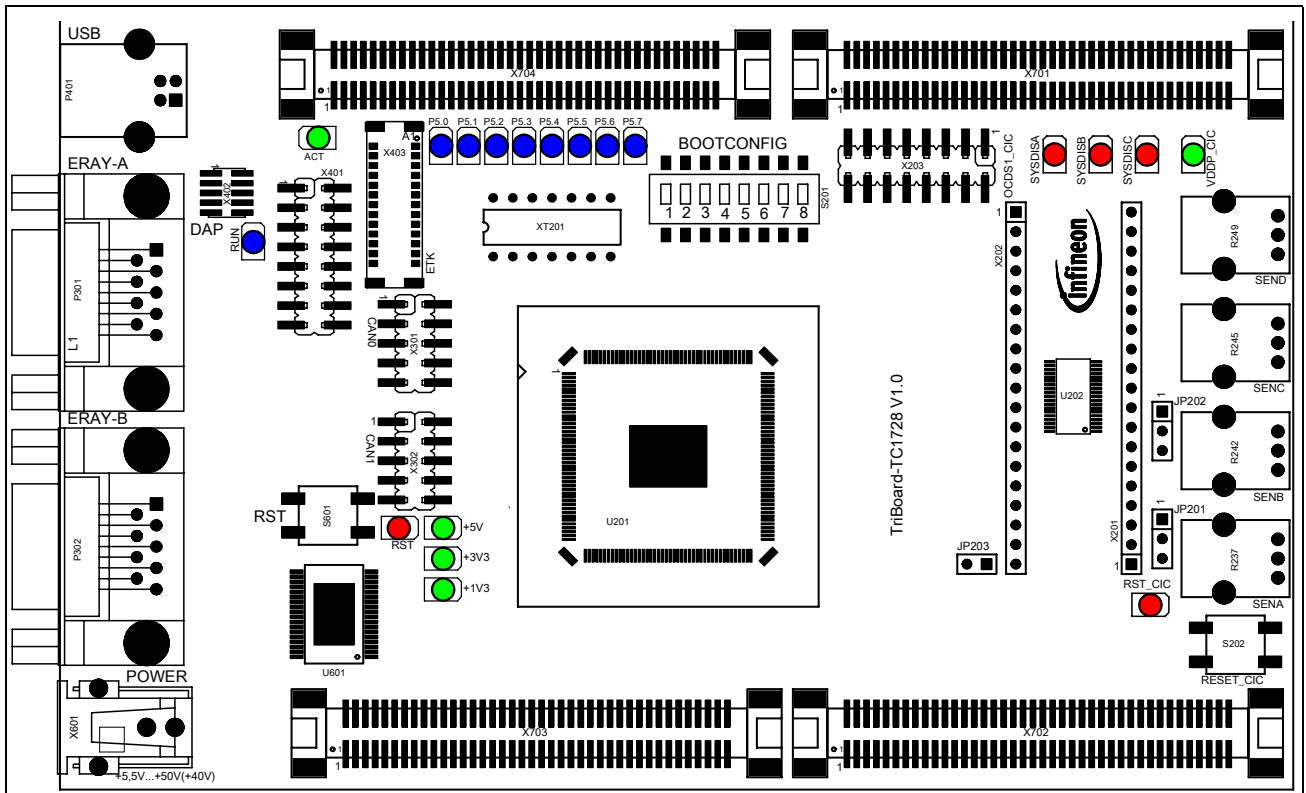

Figure 2-2 TriBoard TC1728 V1.0 Placement

3 TriBoard Information

3.1 Power Supply

The Board has to be connected to a +5,5V to +50V (+40V) DC power supply. The TriBoard generates internally +3.3V, +1V3 and +5V. The power consumption is not specified yet but a supply with 6V and 500mA should be sufficient. The pinout for the supply connector is shown in [Figure 7-3](#). There can be used any standard power pack with a connector where the positive line is surrounded by the ground line.

Maximum power supply is reduced to +40V if the SAK-CIC61508 option is assembled . Applying a stable supply voltage causes the power on reset after a short period. The three LED's (+5V, +3.3V, +1V3) indicate the status of the on board generated voltage. A manual reset is executed by pressing the reset button.

3.2 LEDs

There are 14 or 19 LEDs on board:

- D501 up to D508 (blue) -> toggle LEDs connected to P5.0 ... P5.7
- D604 RST (red) -> RESET LED indicate the reset state of the board
- D505 +1V3 (green) -> +1,3V power supply indication
- D606 +3V3 (green) -> +3,3V power supply indication
- D607 +5V (green) -> +5V power supply indication
- D402 ACT (green) -> on board miniWiggler JDS is ACTIV
- D401 RUN (blue) -> Debug RUN mode (switched by DAS Server)
- D204 RST_CIC (red)-> RESET LED indicate that the CIC is in reset
- D205 +VDDP_CIC (green)-> +VDDP for CIC power supply indication (+3,3V)
- D201 SYSDISA (red)-> System Disable A (switched by CIC)
- D202 SYSDISB (red)-> System Disable B (switched by CIC)
- D203 SYSDISC (red)-> System Disable C (switched by CIC)

3.3 Clock

There are three possibilities to apply the CPU clock.

- Large oscillator circuit (DIP14)
- Small oscillator circuit (DIP8)
- Crystal oscillator (default with 20MHz)
- External clock generator

The crystal oscillator and the oscillator circuit use the socket XT201. It's possible to apply a 14pol DIP oscillator package or an 8pol DIP oscillator package.

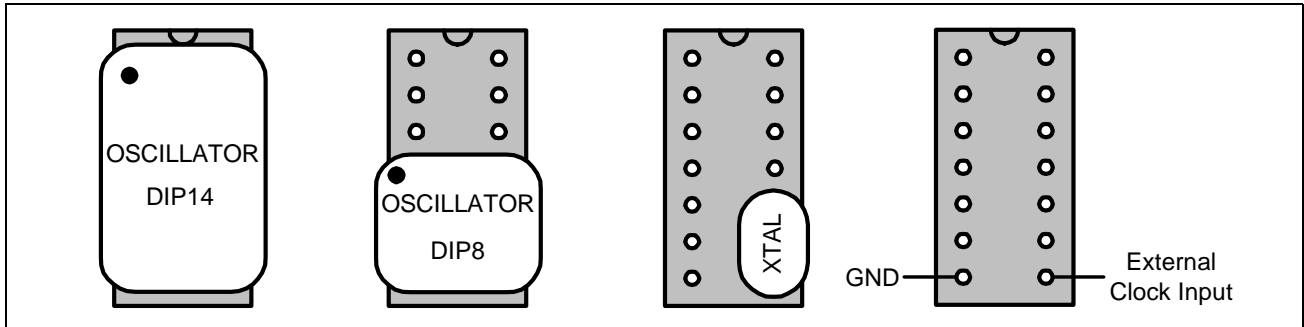

Figure 3-1 Clock socket usage (XT301)

3.4 USB Connector

The USB connector is used for connection to a PC. Via the USB it is possible to using the ASC0 as serial connection via USB and Debugging via DAS. For the pinout of USB socket see [Figure 7-4](#).

NOTE: Before connecting the board to the PC, make sure that the actual DAS software is installed on the PC. For actual DAS software please contact your local FAE.

The software can also be found on the

[*DAS website*](#)

3.4.1 Serial Connection to PC

After the first connection of USB to a PC the needed driver will be installed automatically. During this there will be created a new COM port on PC. This COM port can be used to communicate with the board via ASC0 of the device (e.g. bootstrap loader).

3.4.2 miniWiggler JDS

The miniWiggler JDS is a low cost debug tool which allows you access to the JTAG of the device. Make sure that you have the latest DAS release. Debugging is possible via the DAS Server 'UDAS'. Please contact your preferred debug vendor for support of DAS. If you have connected the board to the PC and there runs the DAS server, then a working connection is visible via the green ACTIV LED.

The status RUN LED is switched on/off through the DAS Server, depending on the used debugger (client).

IMPORTANT: Make sure that there is no or a tristated connection on X401 (OCDS1) and X402 (DAP) if the ACTIV LED is on.

3.5 FlexRay

The board has 2 SUB-D connectors for FlexRay Communication with up to 10 Mbit/s. For the pinout of the plugs see [Figure 7-5](#).

The transceiver are connected directly to the TriCore device.

For more information look in the user manual for TC1728.

3.6 Serial Eeprom

The SSC0 of the TC1728 is connected to a serial EEPROM with a size of 128K (16.384 x 8). As chip select for this EEPROM is used the line SLSO00 (P3.5). To disconnect (disable) the EEPROM remove resistor R353.

3.7 MultiCAN

On the board are two CAN transceiver connected to the MultiCAN on TC1728 node 0 and 1. The transceivers are connected to two IDC10 plug. For the pinout of IDC10 plug see [Figure 7-6](#). You can use a IDC female connector with crimpconnector, flat cable and SUB-D 9 plug with crimpconnector to have a 1:1 adapter to SUB-D 9.

3.8 Safety option with SAK-CIC61508 (optional)

The safety device is only assembled if the board is with TC1728 or with the safety option.

The SAK-CIC61508 is connected to the SSC0 of the microcontroller and use the line SLSO01 (P3.6) as chip select.

There are 4 LED's for indication the state of the safety device (SYSDISA, SYSDISB, SYSDISC, VDDP_CIC).

On this board exists 4 potentiometer to stimulate the sense inputs of the safety device.

Sensor inputs A and B can be connect to a potentiometer (JP201, JP202 , pos. 2-3) or to the core voltage of the microcontroller (JP201, pos. 1-2) for input A or to the port voltage of the microcontroller (JP202, pos. 1-2) for input B.

With switch S202 it is possible to reset the safety device. If JP203 is set, then with S202 is also reset the microcontroller and the safety device is reset by a power on reset of the microcontroller.

The safety device can be reprogrammed via JTAG and X203.

3.9 Other peripherals

For all other peripherals there are no special plugs on the board. The peripheral signals are available on the different connectors. See [“Connector Pin Assignment” on Page 7-1](#).

Note: - SLSO00 is used as chip select for the serial eeprom on board.

3.10 Toggle LED's

Port 5pin 0 up to pin 7 are connected to single LED's (D501... D508) and can be controlled by Software. This status LED's are low active.

3.11 Debug System

3.11.1 OCDS1

The OCDS1 signals are connected to the IDC16 plug (X401). They work with the port supply of +3.3V. For pinout of the connector see [Figure 7-7](#). You can connect any debugger to this connector.

The signals /BRKIN and /BRKOUT are not connected per default. If you need this signals in the connector then assemble R425 and R424 with a 0R resistor.

If you connect a debug hardware make sure that the miniWiggler JDS (see [“miniWiggler JDS” on Page 3-2](#)) is not activ (ACTIV LED is off) and on the DAP connector (X402) is no hardware connected or the hardware is tristated.

If the ACTIV LED is on, then stop the active DAS Server 'UDAS' and/or remove the USB connection to the PC.

3.11.2 DAP

The board comes with a DAP connector (X402). For pinout of this connector see [Figure 7-8](#). You can connect a DAP hardware here. If you use this connector make sure that the miniWiggler JDS is not activ (ACTIV LED is off) and a connected OCDS1 hardware is disconnected or tristated.

4 TriBoard Configuration

4.1 HW Boot Configuration TC1728

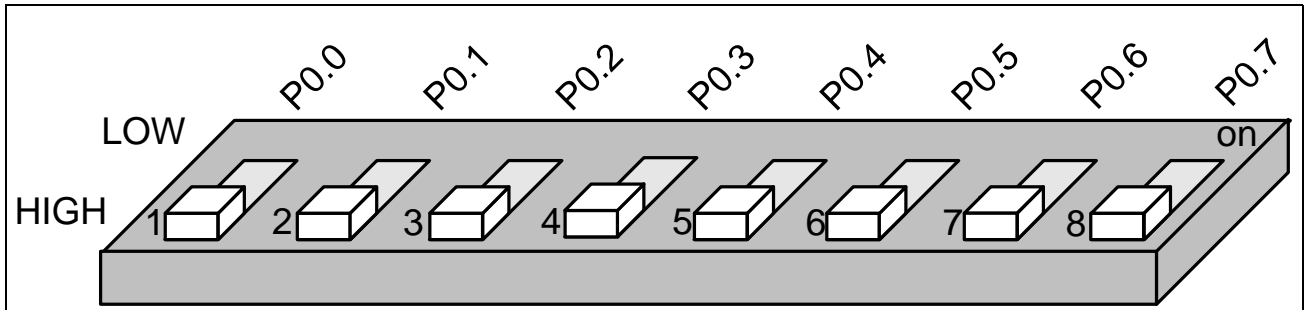

Figure 4-1 HW Configuration TC1728 DIP-Switch

The picture above shows the definition of the boot HW configuration switch. The meaning of the switches will be described in the following table ([Table 4-1](#)).

Note: The ON position of the switch is equal to a logical LOW at the dedicated pin.

Table 4-1 User Startup Modes for TC1728

Note: The shadowed line indicates the default setting.

Note: 'x' represents the don't care state.

Note: 1 to 8 are the Dip Switch numbers

HWCFG[7...0]	Type of Boot TC1728	1	2	3	4	5	6	7	8
11XXXXXX	Internal Start from Flash	X	X	X	X	X	X	O	O
01XXXXXX	Generic (CAN/ASC auto detected) Bootstrap Loader - P3[13:12]	X	X	X	X	X	X	O	O
10XXXXXX	Alternate Boot Mode, Generic Bootloader on fail - P3[13:12]	X	X	X	X	X	X	O	O
00XX10XX	ASC Bootstrap Loader - P3[1:0]	X	X	O	O	X	X	O	O

Table 4-1 User Startup Modes for TC1728

Note: The shadowed line indicates the default setting.

Note: 'x' represents the don't care state.

Note: 1 to 8 are the Dip Switch numbers

HWCFG[7...0]	Type of Boot TC1728	1	2	3	4	5	6	7	8
00XX11XX	Alternate Boot Mode, ASC Bootloader on fail - P3[1:0]	X	X	O F F	O F F	X	X	O N	O N
all others	reserved; don't use this combination								

4.2 Assembly Options

Table 4-2 General optional resistors

Component	Description
R205	XTAL Rserial (default: assembled)
R206	XTAL Rparallel (default: not assembled)
R423	Connect /BRKOUT with miniWiggler JDS (default: not assembled)
R424	Connect /BRKOUT with OCDS1 connector (default: not assembled)
R427	Connect /BRKIN with USB1 of miniWiggler JDS (default: not assembled)
R429	Connect /BRKIN with USB1 of DAP (default: not assembled)
R425	Connect /BRKIN with OCDS1 connector(default: not assembled)
R428	Connect /TESTMODE with USB1 of miniWiggler JDS (default: not assembled)
R430	Connect /TESTMODE with USB1 of DAP (default: not assembled)
R426	Connect /TESTMODE with OCDS1 connector(default: not assembled)
R432	Connect debug reset with /PORST(default: assembled)
R431	Connect debug reset with /HDRST (default: not assembled)
R510	Connect +3,3V to all toggle LEDs (default: assembled)
R623	Connect reset switch with /PORST(default: assembled)
R624	Connect reset switch with /HDRST (default: not assembled)
R604	Connect P1.10 with MONSTBY of power device (default: not assembled)
R606	Connect P1.3 with WDO of power device (default: not assembled)
R609	Connect P1.15 with WDI of power device (default: not assembled)

Table 4-3 Resistors for peripherals

Component	Description
R333	Connect P3.12 with RXD of CAN0 transceiver (default: assembled)
R339	Connect P3.14 with RXD of CAN1 transceiver (default: assembled)
R353	Connect P3.5 (SLSO00) with /CS of Eeprom (default: assembled)
R440	Connect P3.0 with TXD of USB to UART (default: assembled)
R505	Connect VAREF0 with VDDM (default: assembled)
R507	Connect VAGND0 with VSSM (default: assembled)
R519	Connect +5V with VDDM (default: assembled)
R520	Connect +3,3V with VDDM (default: not assembled)

Note: All resistors are red marked in the following figures

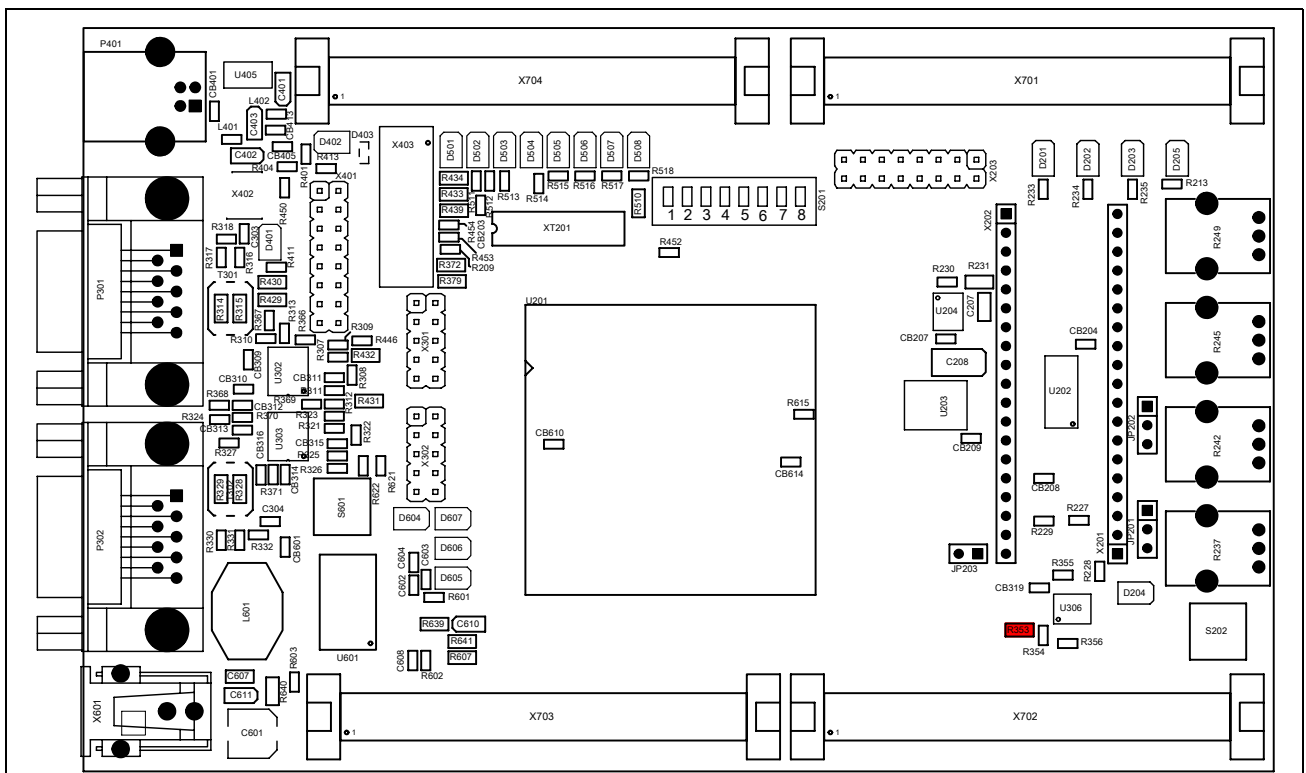

Figure 4-4 Location of peripheral resistors on Top Side

TriBoard Configuration

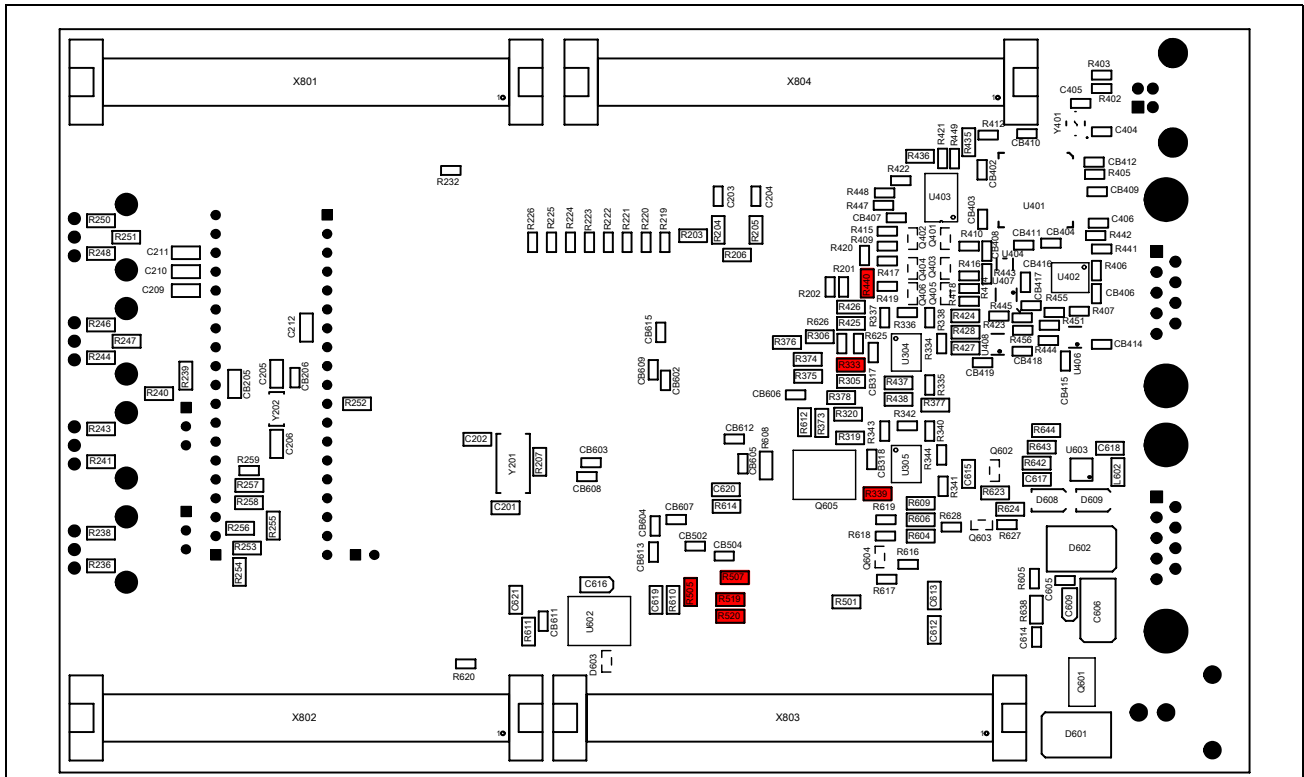

Figure 4-5 Location of peripheral resistors on Bottom Side

Table 4-4 Resistors for safety device

Component	Description
R247	Connect potentiometer to sensor input C (default: assembled)
R251	Connect potentiometer to sensor input D (default: assembled)
R239/R240	Voltage divider to adapt VDDP to VAREF of safety device (default: assembled)
R252	Connect P3.6 (SLSO01) with /CS of safety device (default: assembled)
R253	Connect P3.2 (SSC0) to SCLK of safety device (default: assembled)
R254	Connect P2.11 (SSC1) to SCLK of safety device (default: not assembled)
R255	Connect P3.4 (SSC0) to MTSR of safety device (default: assembled)
R256	Connect P2.12 (SSC1) to MTSR of safety device (default: not assembled)
R257	Connect P3.3 (SSC0) to MRST of safety device (default: assembled)
R258	Connect P2.10 (SSC1) to MRST of safety device (default: not assembled)



5 TriBoard Software

5.1 Requirements

To install the software from your TriBoard CD you need a PC with Windows95/98/ME, Windows 2000, Windows XP, Windows Vista or Windows 7.

5.2 Software Overview

The CD does not contain any tool. For the availability for Demo Versions of the different Tools, please contact the toolvendor directly (e.g. Tasking, Hitex, Lauterbach, GreenHills, HighTec...). To install tools for compiling and debugging use separate CD's from Toolvendors. There are also some application notes and software examples. The data sheets of all used parts can be found in the "TriBoard_Components" directory. The manuals for the microcontrollers and the Easy Kit are located in the "Manual" folder. Some useful tools like Acrobat Reader are stored in the "Utilities" directory.

The current Errata Sheet can be found in the directory "Errata Sheet". To make sure you have always the most recent one, please contact your local FAE.

Note: For more details see the file ReadMe.txt.

5.3 Software Installation

To install tools for the TriCore insert the CD from the Toolvendor and start the file "setup.exe" if the CD is not automatically started. Follow the instructions of the installation program.



6 Signal Description

For more information about the signals please see the user manuals for TC1728 and/or the schematics of the board.

Table 6-1 Power Signals

Short Name	Description
VCC_IN	Supply Input (5,5V...50V(40V))
VIN	Input voltage of power supply device
GND	Ground
VDD	Core Supply Voltage (1,3V)
VDDP	Port Supply Voltage (3,3V)
V5	EVR Supply Voltage (5V)
VDDESB	Emulation Stand-by SRAM Supply Voltage (1,3V)
VSSM	ADC Analog Part Ground
VDDM	ADC Analog Part Supply Voltage (5V)
VAGND0	ADC Reference Ground
VAREF0	ADC0 Reference Voltage (VDDM)
VDDP_CIC	Port Supply Voltage safety device (3,3V)
VAGND_CIC	ADC Reference Ground safety device
VAREF_CIC	ADC Reference Voltage safety device (2,5V)

Table 6-2 Reset Signals

Short Name	Description
/PORST	Power On Reset
/ESR0_/HDRST	External Service Request 0 (Hardware Reset)
/RESET_CIC	Reset safety device

Table 6-3 Interrupt Signals

Short Name	Description
/ESR1_/NMI	External Service Request 1 (Non Maskable Interrupt)
REQ[0...1] / P3[10...11]	External Trigger Input 0...1
REQ[2...3] / P0[6...7]	External Trigger Input 2...3
REQ[4...5] / P0[14...15]	External Trigger Input 4...5

Table 6-3 Interrupt Signals

REQ9 / P0.11	External Trigger Input 9
REQ15 / P1.0	External Trigger Input 15

Table 6-4 Clock Signals

Short Name	Description
XTAL1	Crystal Oscillator Input
XTAL2	Crystal Oscillator Output
XTAL1_CIC	Crystal Oscillator Input safety device
XTAL2_CIC	Crystal Oscillator Output safety device

Table 6-5 Debug Signals

Short Name	Description
/TRST	Test Reset
TCLK	Test Clock
TMS	Test Mode Select
TDI	Test Data Input
TDO	Test Data Output
/TESTMODE	Test Mode Select Input
/BRKIN	TriCore Breakpoint Input
/BRKOUT	TriCore Breakpoint Output
TCLK_CIC	Test Clock safety device
TMS_CIC	Test Mode Select safety device
TDI_CIC	Test Data Input safety device
TDO_CIC	Test Data Output safety device
MBC_CIC	Monitor & Bootstrap loader Control line safety device

Table 6-6 Peripheral Signals

Short Name	Description
P3.0	Receive Data ASC0
P3.1	Transmit Data ASC0
P3.9	Receive Data ASC1
P3.8	Transmit Data ASC1
SCLK0 / P3.2	Clock Line SSC0

Table 6-6 Peripheral Signals

MRST0 / P3.3	Master Receive / Slave Transmit SSC0
MTSR0 / P3.4	Master Transmit / Slave Receive SSC0
SLSOX0 / P3.5	Slave Select Output 0 (SSCX)
SLSOX1 / P3.6	Slave Select Output 1 (SSCX)
SLSOX2 / P3.7	Slave Select Output 2(SSCX)
P2.11	Clock Line SSC1
P2.10	Master Receive / Slave Transmit SSC1
P2.12	Master Transmit / Slave Receive SSC1
P3.13	CAN Transmitter Output 0
P3.12	CAN Receiver Input 0
P3.15	CAN Transmitter Output 1
P3.14	CAN Receiver Input 1
P4.1	CAN Transmitter Output 2
P4.0	CAN Receiver Input 2
P0 [0...7]	General Purpose I/O Port 0 (HWCFG)
P5 [0...7]	General Purpose I/O Port 5 (used for LED's)
P5.8	E-Ray Channel A transmit Data Output
P5.10	E-Ray Channel A transmit Data Output enable
P5.14	E-Ray Channel A Receive Data Input 0
P5.9	E-Ray Channel B transmit Data Output
P5.11	E-Ray Channel B transmit Data Output enable
P5.15	E-Ray Channel B Receive Data Input 0
P2.4	MLIO receive channel clock
P2.5	MLIO receive channel ready output
P2.6	MLIO receive channel valid input
P2.7	MLIO receive channel data input
P2.0	MLIO transmit channel clock
P2.1	MLIO transmit channel ready input
P2.2	MLIO transmit channel valid output
P2.3	MLIO transmit channel data output
P6.1 / FCLP0A	MSC0 differential driver clock output positive A

Table 6-6 Peripheral Signals

P6.0 / FCLN0	MSC0 differential driver clock output negative
P6.3 / SOP0A	MSC0 differential driver serial data output positive A
P6.2 / SON0	MSC0 differential driver serial data output negative
AN[0...35]	Analog Inputs
P1[12...14]	ADC0 External Multiplexer Control
P0[0...15]	General Purpose I/O Port 0
P1[0...15]	General Purpose I/O Port 1
P2[0...13]	General Purpose I/O Port 2
P3[0...15]	General Purpose I/O Port 3
P4[0...3]	General Purpose I/O Port 4
P5[0...15]	General Purpose I/O Port 5
P6[0...3]	General Purpose I/O Port 6
P8[0...14]	General Purpose I/O Port 8
P9[2...8]	General Purpose I/O Port 9
P10[0...3]	General Purpose I/O Port 10
P11[0...15]	General Purpose I/O Port 11

Table 6-7 Safety device Signals

Short Name	Description
SENA	Sensor Input A
SENB	Sensor Input B
SENC	Sensor Input C
SEND	Sensor Input D
SCLK_CIC	Clock Line SAK-CIC61508
MRST_CIC	Master Receive / Slave Transmit SAK-CIC61508
MTSR_CIC	Master Transmit / Slave Receive SAK-CIC61508
/CS_CIC	Slave Select Input SAK-CIC61508
SYSDISA	System Disable Output A
SYSDISB	System Disable Output B
SYSDISC	System Disable Output C

7 Connector Pin Assignment

The TriBoard will be shipped with four male (plug) connectors on top layer and four female (socket) connectors on bottom layer. The default connectors are 80-pol. Board to Board connectors from Samtec:

<http://www.samtec.com>

Plug:

FTSH-140-02-L-DV-ES-A

Socket:

FLE-140-01-G-DV-A

Connector Pin Assignment

7.1 TC1728 Connector / Top View

BUS EXPANSION (X801,X901)				PERIPHERALS (X802,X902)			
GND	1	2	GND	GND	1	2	GND
GND	3	4	GND	GND	3	4	GND
	5	6		VCC_IN	5	6	VCC_IN
	7	8		VCC_IN	7	8	VCC_IN
	9	10			9	10	
	11	12			11	12	
	13	14			13	14	
	15	16		/ESR1	15	16	/ESR0
	17	18			17	18	
	19	20		GND	19	20	GND
	21	22			21	22	/PORST
	23	24			23	24	
	25	26		EN00 / P2.8	25	26	EN01 / P2.9
	27	28		SDI0 / P2.13	27	28	
	29	30		FCLP0A / P6.1	29	30	P1.15
	31	32		FCLN0 / P6.0	31	32	P9.5
	33	34		SOP0A / P6.3	33	34	P9.6
	35	36		SON0 / P6.2	35	36	
	37	38			37	38	
	39	40			39	40	SLSI1 / P2.13
	41	42		SLSO00_10 / P3.5	41	42	SLSO01_11 / P3.6
	43	44		SLSO02_12 / P3.7	43	44	SLSO03_13 / P2.1
	45	46		SLSO04_14 / P2.8	45	46	SLSO05_15 / P2.9
	47	48		SLSO06 / P3.8	47	48	SLSO17 / P1.10
	49	50		GND	49	50	GND
	51	52		XTAL1	51	52	SYSCLK / P4.3
	53	54		XTAL2	53	54	
	55	56		RXD0 / P3.0	55	56	RXD1 / P3.9
	57	58		TXD0 / P3.1	57	58	TXD1 / P3.8
	59	60		RXDCAN0 / P3.12	59	60	RXDCAN1 / P3.14
	61	62		TXDCAN0 / P3.13	61	62	TXDCAN1 / P3.15
	63	64		SCLK0 / P3.2	63	64	SCLK1 / P2.11
	65	66		MTSR0 / P3.4	65	66	MTSR1 / P2.12
	67	68		MRST0 / P3.3	67	68	MRST1 / P2.10
	69	70			69	70	
	71	72		REQ0 / P3.10	71	72	REQ1 / P3.11
	73	74		REQ2 / P0.6	73	74	REQ3 / P0.7
	75	76		VDDESB	75	76	GND
	77	78		3V3	77	78	3V3
	79	80		3V3	79	80	3V3

Figure 7-1 Connector for TC1728 - Pinout (Part I, Top View)

Connector Pin Assignment

ADC (X803, X903)			GPTA / MLI (X804,X904)		
VSSM	1 2	VSSM	GND	1 2	GND
VSSM	3 4	VSSM	GND	3 4	GND
AN0	5 6	AN16	P0.0	5 6	P5.8
AN1	7 8	AN17	P0.1	7 8	P5.9
AN2	9 10	AN18	P0.2	9 10	P5.10
AN3	11 12	AN19	P0.3	11 12	P5.11
AN4	13 14	AN20	P0.4	13 14	P5.12
AN5	15 16	AN21	P0.5	15 16	P5.13
AN6	17 18	AN22	P0.6	17 18	P5.14
AN7	19 20	AN23	P0.7	19 20	P5.15
AN8	21 22	AN24	P0.8	21 22	P5.0
AN9	23 24	AN25	P0.9	23 24	P5.1
AN10	25 26	AN26	P0.10	25 26	P5.2
AN11	27 28	AN27	P0.11	27 28	P5.3
AN12	29 30	AN28	P0.12	29 30	P5.4
AN13	31 32	AN29	P0.13	31 32	P5.5
AN14	33 34	AN30	P0.14	33 34	P5.6
AN15	35 36	AN31	P0.15	35 36	P5.7
VSSM	37 38	VSSM	P1.0	37 38	
VDDM	39 40	VDDM	P1.1	39 40	
	41 42		P1.2	41 42	P9.2
VAGND0	43 44	VAGND0	P1.3	43 44	P9.3
VAREF0	45 46		P1.4	45 46	P9.4
VSSM	47 48	VSSM	P1.5	47 48	P9.7
AN32	49 50		P1.6	49 50	P9.8
AN33	51 52		P1.7	51 52	P8.0
AN34	53 54		P1.8	53 54	P8.1
AN35	55 56		P1.9	55 56	P8.2
	57 58		P1.10	57 58	EMGSTOP / P1.4
	59 60		P1.11	59 60	P8.3
VSSM	61 62	VSSM	P4.0	61 62	P8.4
P8.8	63 64	P8.9	P4.1	63 64	P8.5
P8.10	65 66	P8.11	P4.2	65 66	P8.6
P8.12	67 68	P8.13	P4.3	67 68	P8.7
3V3	69 70	3V3	TCLK0 / P2.0	69 70	RDATA0 / P2.7
AD0EMUX0 / P1.12	71 72	P10.0	TREADY0 / P2.1	71 72	RVALID0 / P2.6
AD0EMUX1 / P1.13	73 74	P10.1	TVALID0 / P2.2	73 74	RREADY0 / P2.5
AD0EMUX2 / P1.14	75 76	P10.2	TDATA0 / P2.3	75 76	RCLK0 / P2.4
	77 78	REQ4 / P0.14	3V3	77 78	3V3
REQ5 / P0.15	79 80	P10.3	3V3	79 80	3V3

Figure 7-2 Connector for TC1728 - Pinout (Part II, Top View)

7.2 Power connector pinout

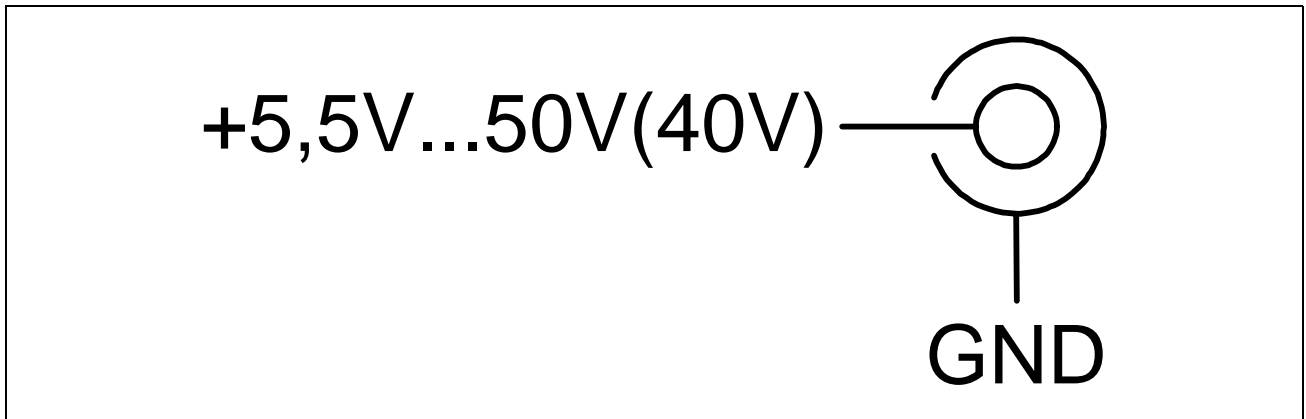

Figure 7-3 Power connector pinout

7.3 USB connector pinout

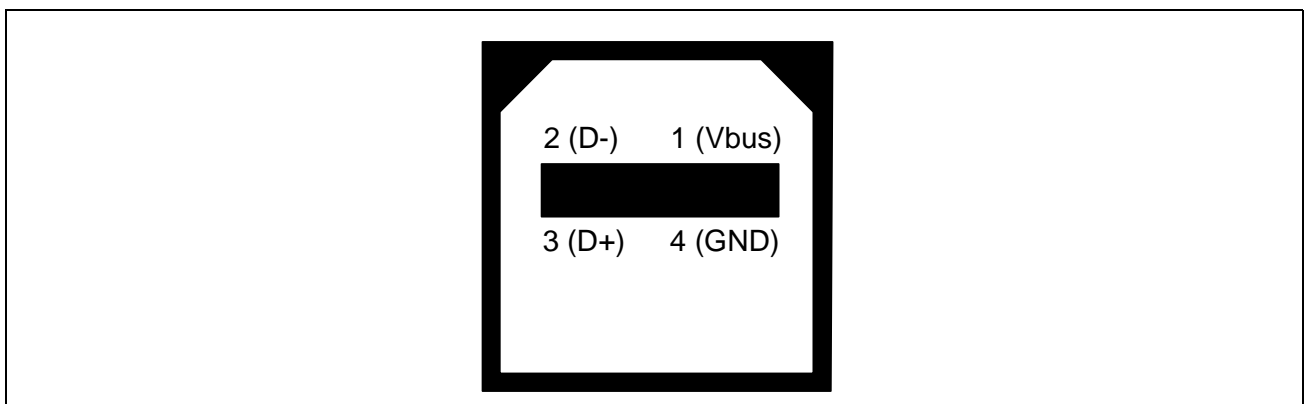

Figure 7-4 USB connector Pinout

7.4 Flexray Pinout

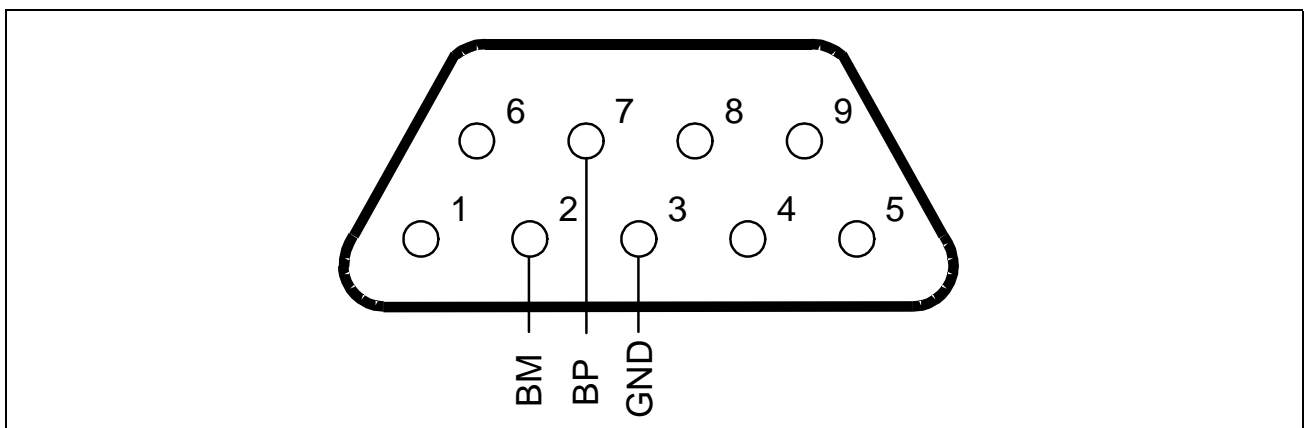

Figure 7-5 Flexray Pinout (SUBD-9 Plug)

7.5 CAN connector pinout

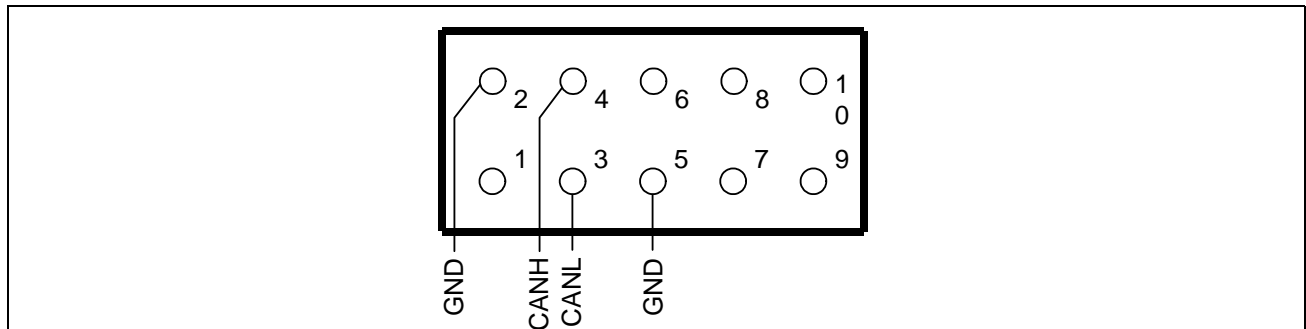

Figure 7-6 CAN connector pinout (IDC10)

7.6 OCDS connector pinout

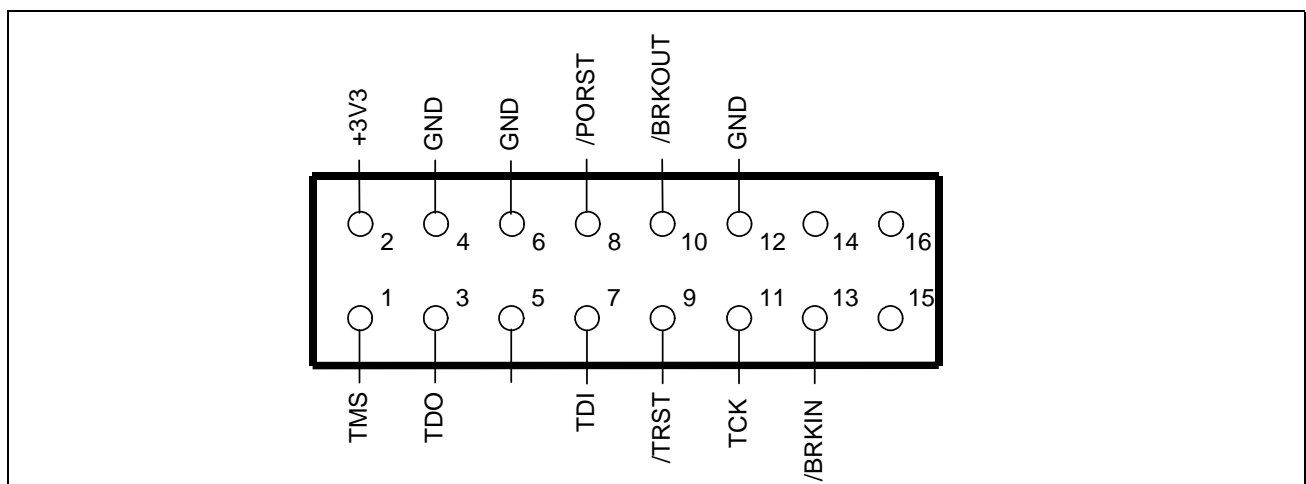

Figure 7-7 OCDS connector pinout (IDC16)

7.7 DAP connector pinout

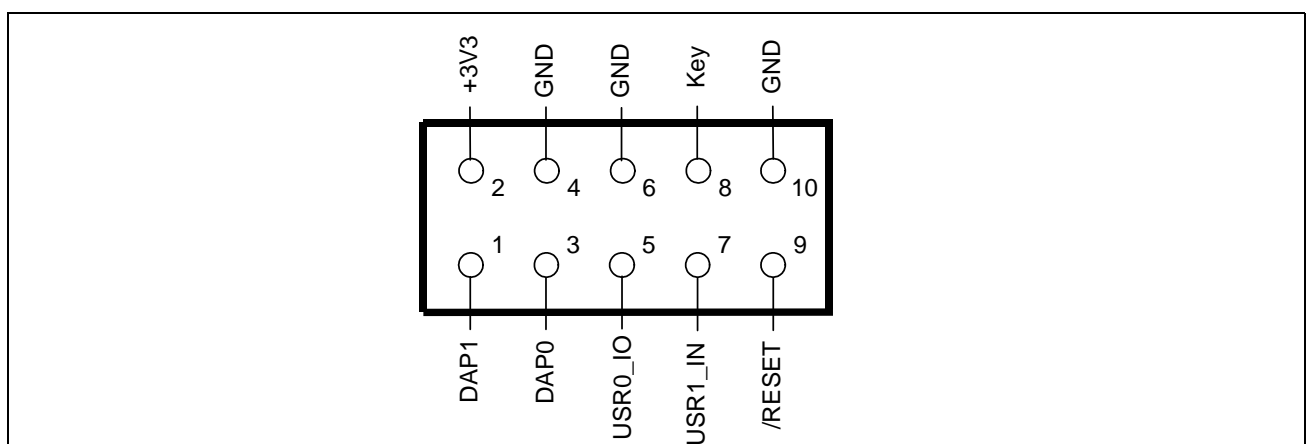

Figure 7-8 DAP connector pinout (FTSH10)



8 Schematic and Layout

8.1 Schematic

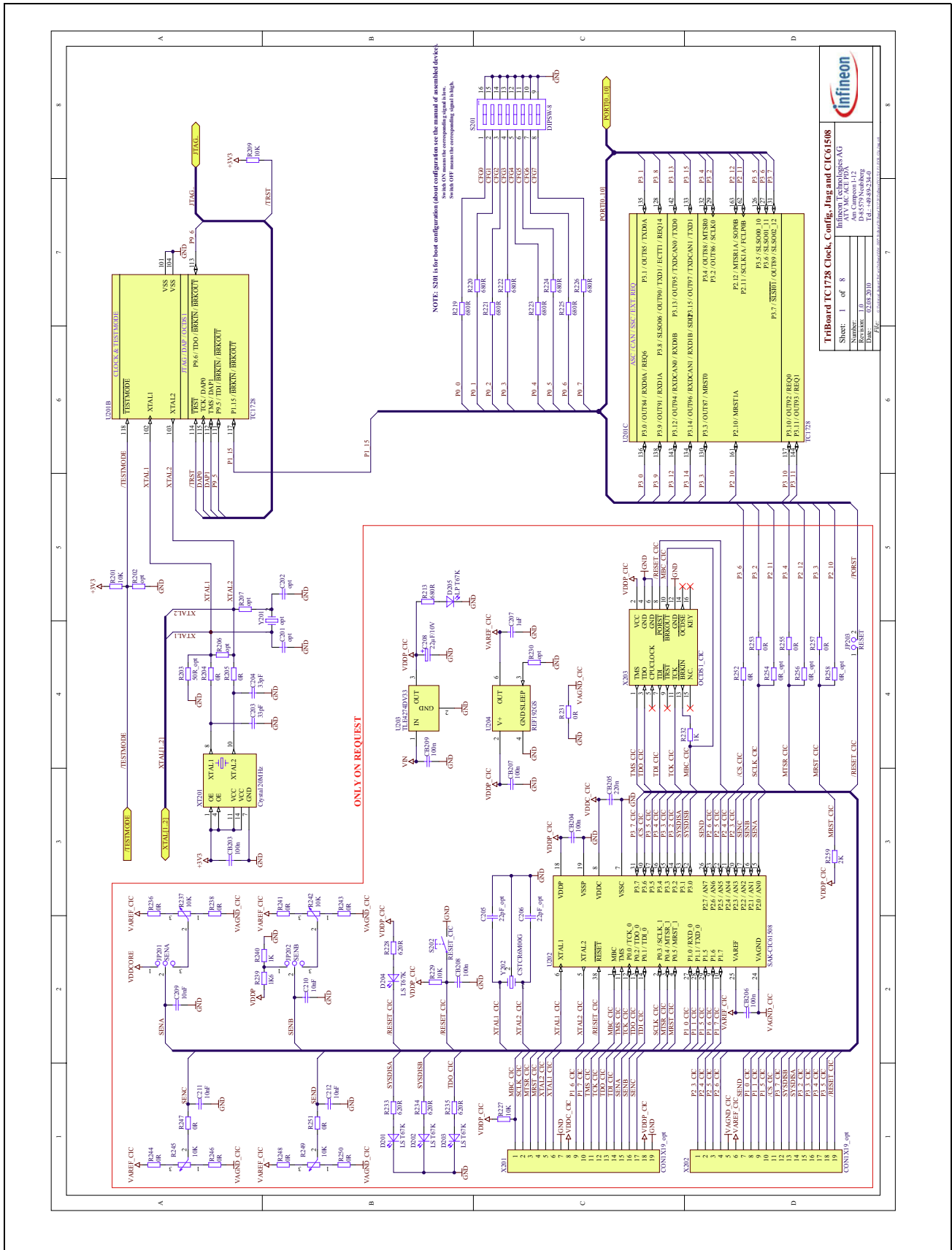

Figure 8-2 Schematic - Config, Clock, JTAG and IC61508

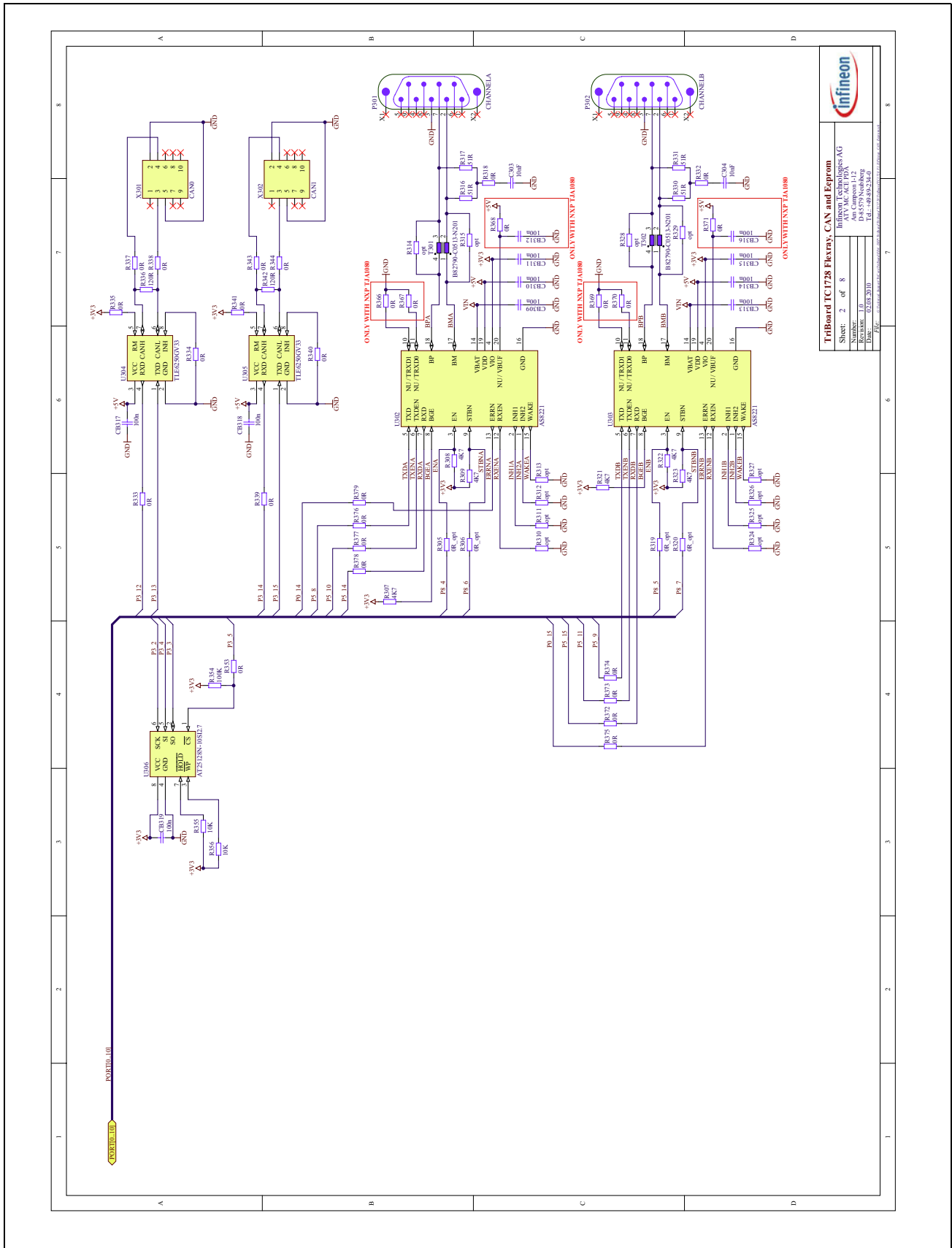

Figure 8-3 Schematic - Flexray, CAN and Eeprom

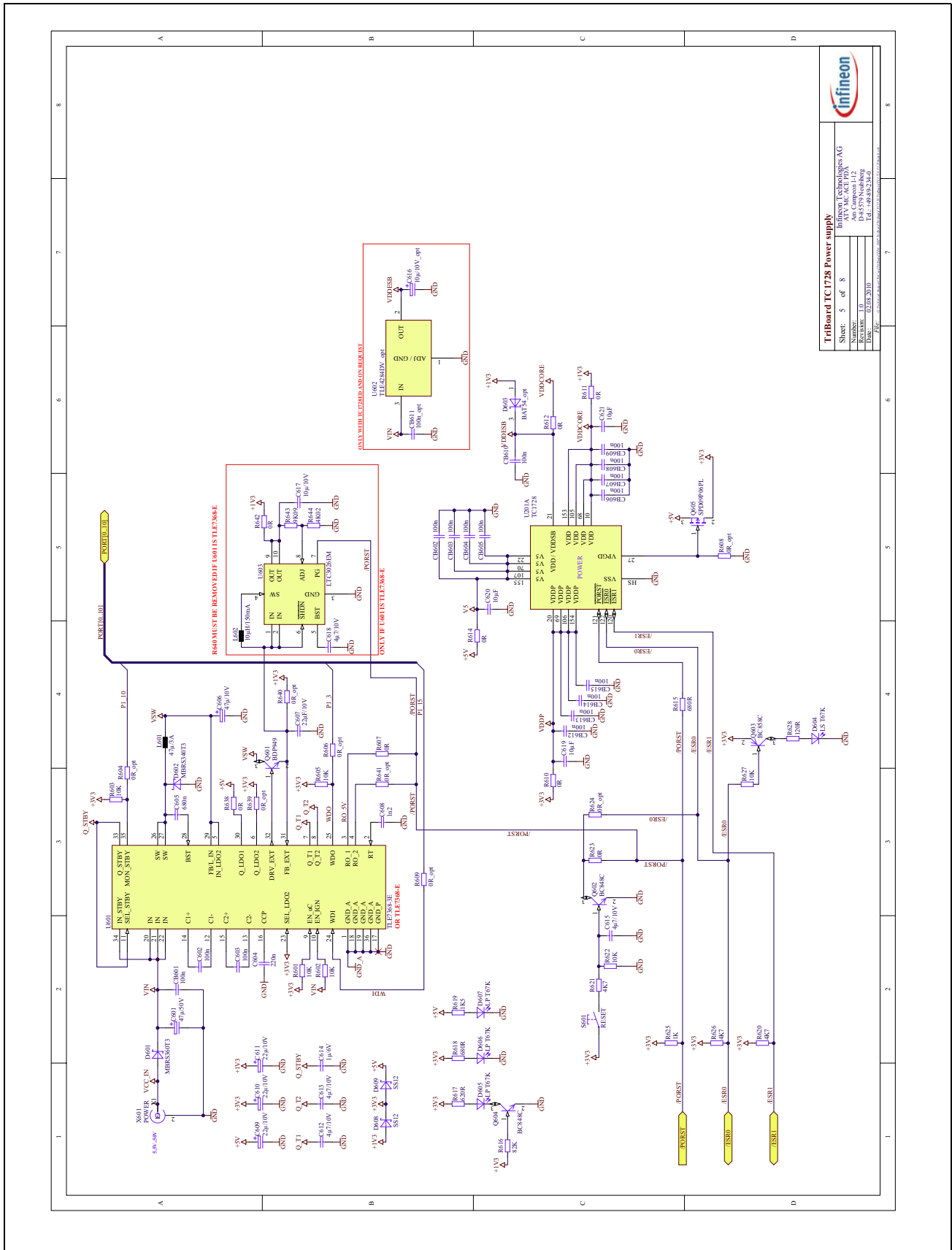

Figure 8-6 Schematic - Power Supply

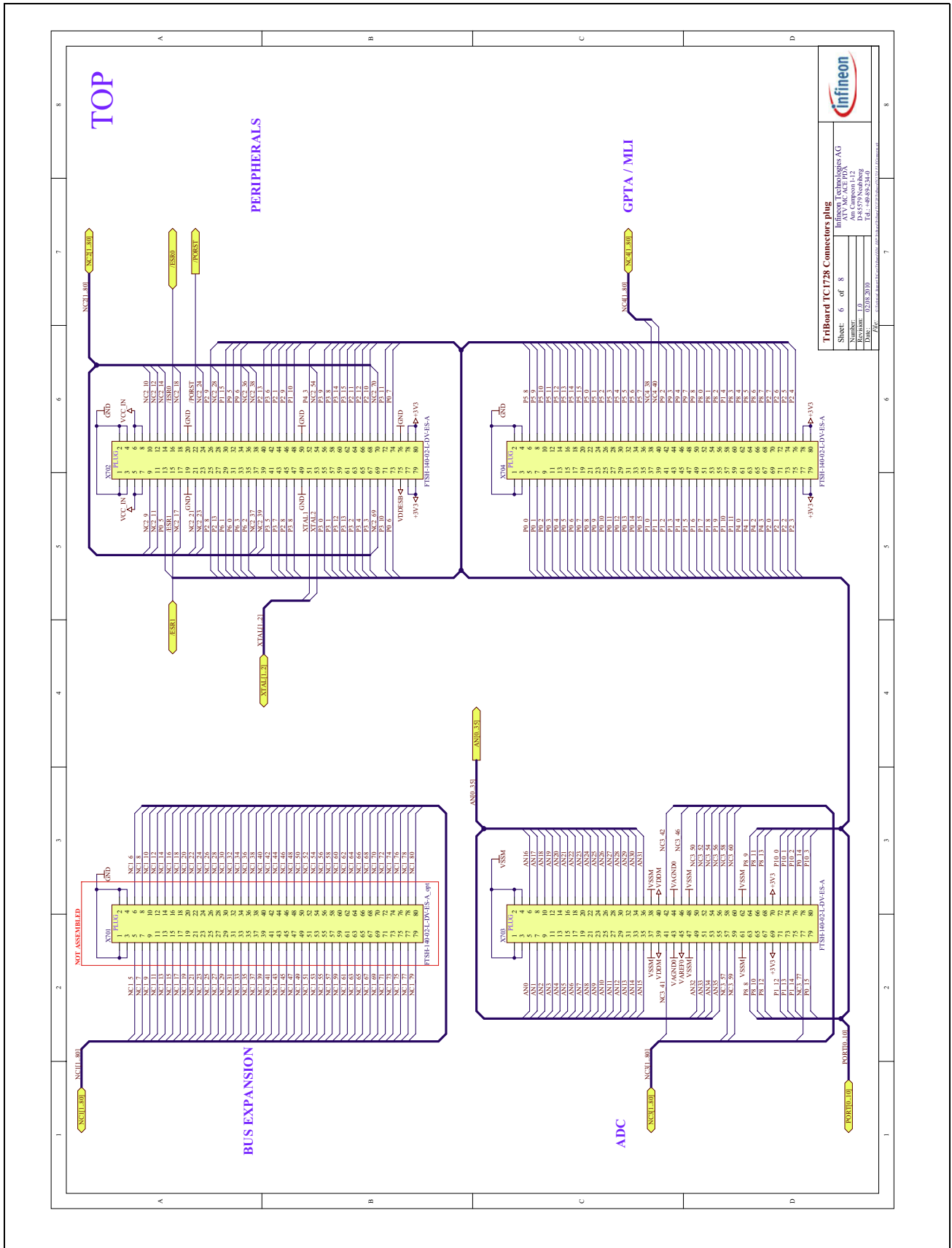

Figure 8-7 Schematic - Connectors (Plug)

8.2 Layout

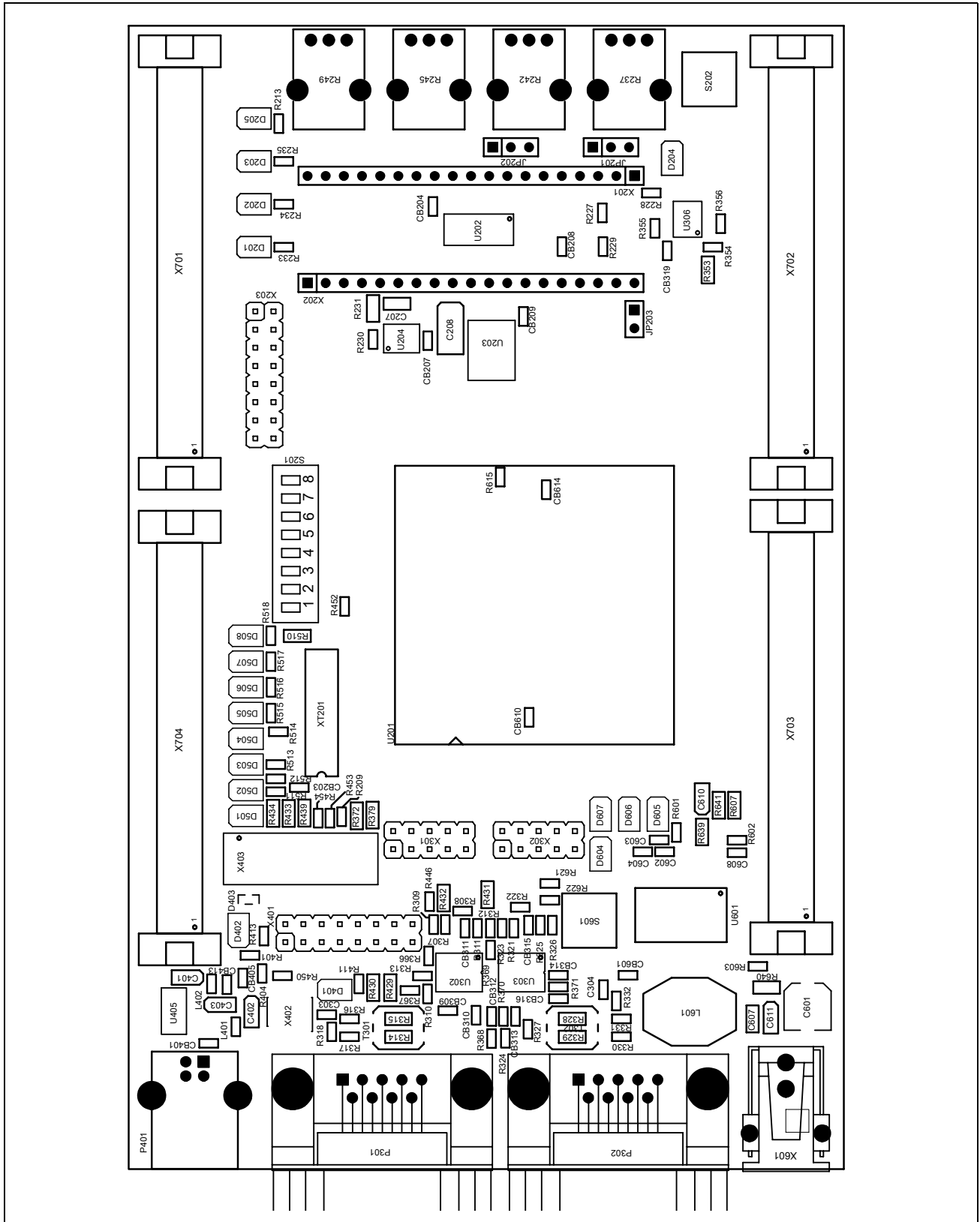

Figure 8-9 Component Plot Top Layer

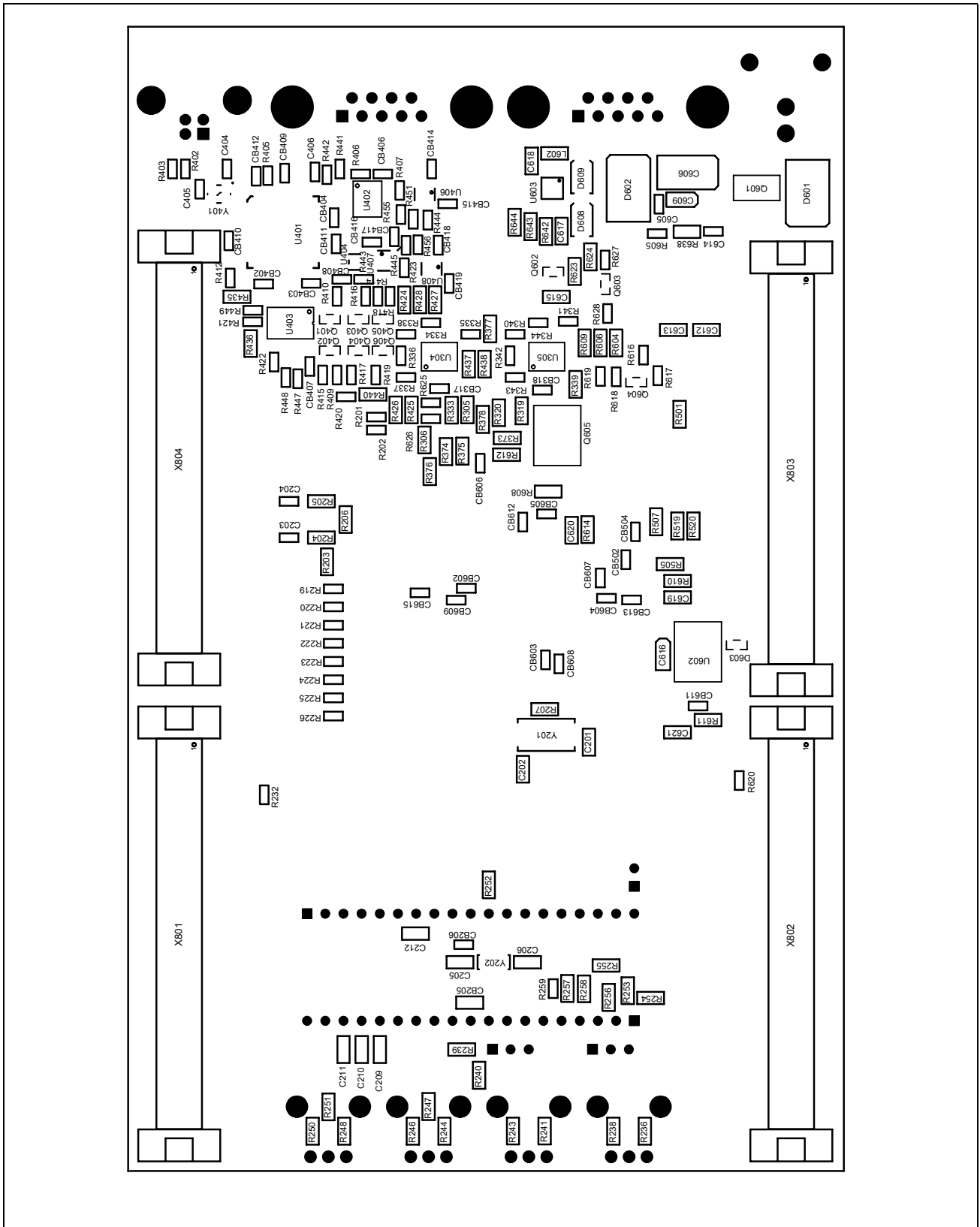
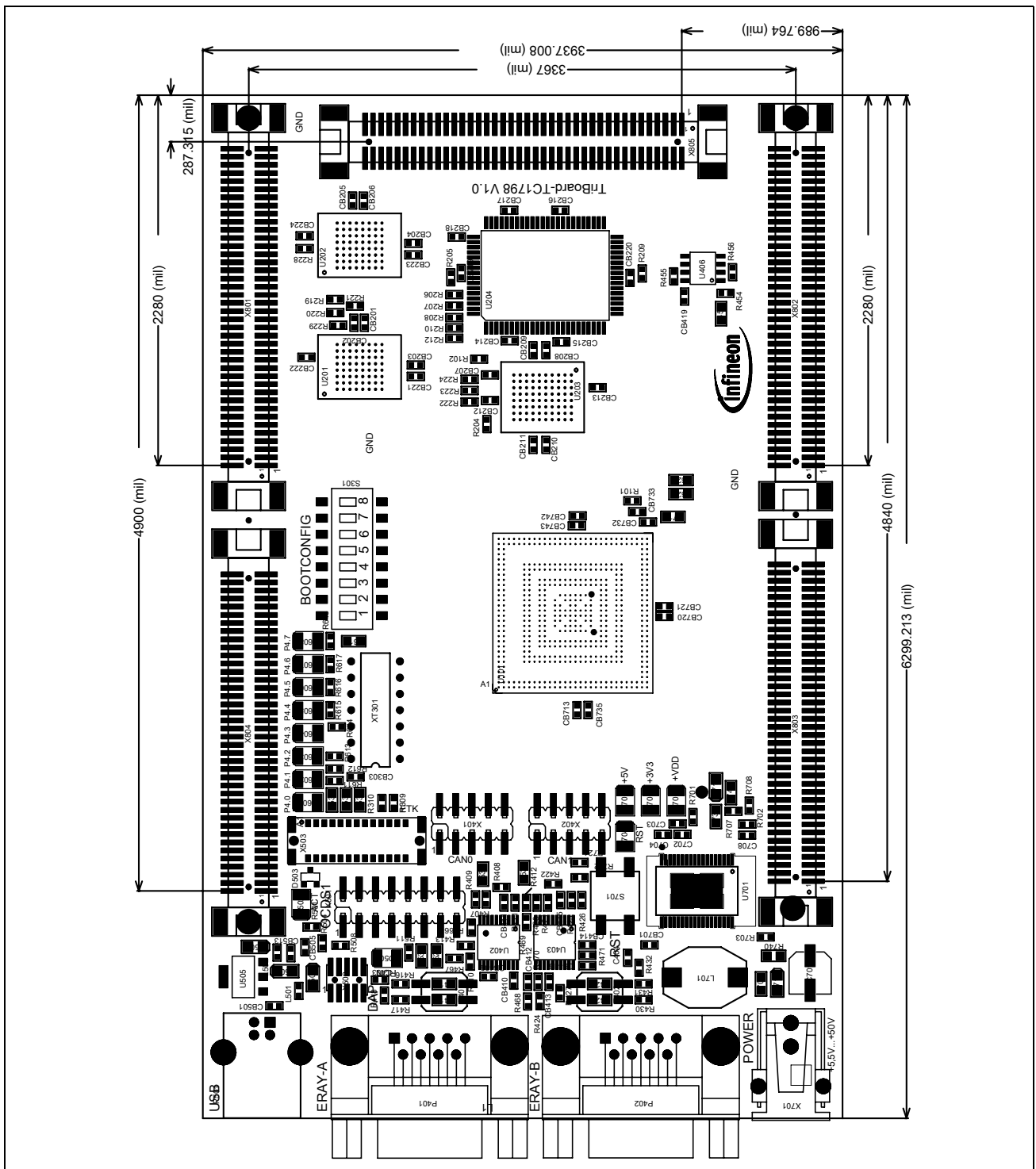

Figure 8-10 Component Plot Bottom Layer

8.3 Layout with Dimensioning

The following dimensions should be used for development of extension boards.

Note: these are the pictures from the TriBoard TC1798. Connectors X801...X804 are on the same place.



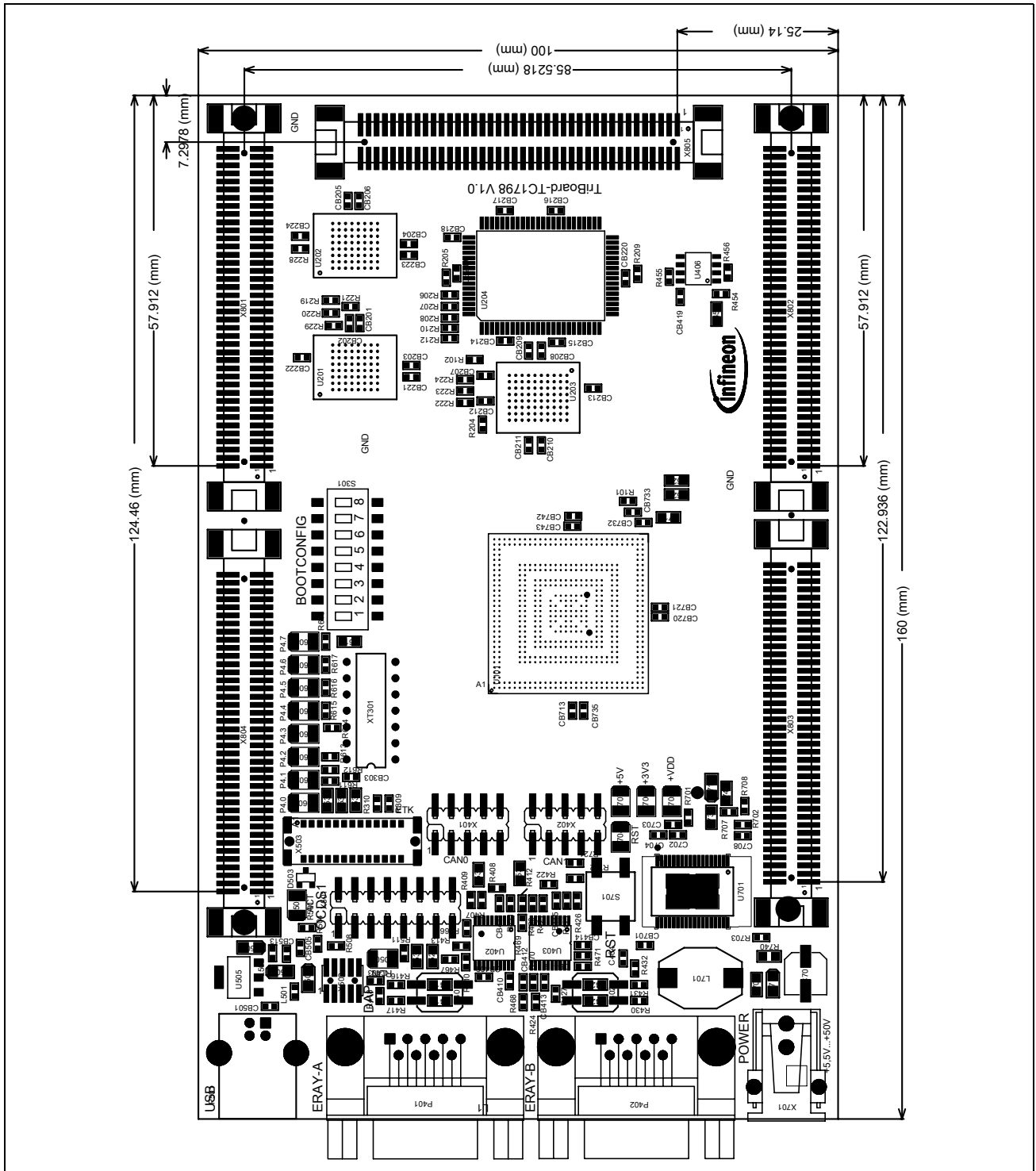

Figure 8-12 Dimensioning (mm)

Keyword Index

A

ACTIV LED 3-2
Assembly Options 4-3

C

CAN connector pinout 7-5
Clock 3-1
Clock Signals 6-2
Connector for TC1728 7-2
Connector Pin Assignment 7-1
CPU clock 3-1
Crystal oscillator 3-1

D

DAP 3-4
DAP connector pinout 7-5
Debug Signals 6-2
Debug System 3-4
Dimensioning 8-12

E

External clock 3-1

F

Flexray Pinout 7-4

G

General optional resistors 4-3

H

HW Boot Configuration 4-1
HWCFG 4-1

I

Interrupt Signals 6-1

L

Layout 8-10
LEDs 3-1
Location of general optional resistors on

Bottom Side 4-4
Location of general optional resistors on
Top Side 4-4
Location of peripheral resistors on Bottom
Side 4-6
Location of peripheral resistors on Top
Side 4-5
Location of resistors for safety device on
Bottom Side 4-7

M

manual reset 3-1
miniWiggler JDS 3-2
MultiCAN 3-3

O

OCDS connector pinout 7-5
OCDS1 3-4
oscillator circuit 3-1
Other peripherals 3-3

P

Peripheral Signals 6-2
Power connector pinout 7-4
Power Signals 6-1
power supply 3-1

R

reset 3-1
Reset Signals 6-1
Resistors for peripherals 4-5
Resistors for safety device 4-6
RUN LED 3-2

S

Safety device Signals 6-4
Safety option 3-3
Samtec 7-1
Schematic 8-1
Schematic and Layout 8-1
Serial Connection to PC 3-2

Serial EEPROM 3-3
Serial Eeprom 3-3
Signal Description 6-1
Software 5-1
status LED 3-4
Supply 3-1

T

Toggle LED's 3-4
TriBoard Software 5-1
TriBoard TC1728 V1.0 Placement 2-4
Type of Boot TC1728 4-1

U

USB Connector 3-2
USB connector pinout 7-4

www.infineon.com

Published by Infineon Technologies AG



Стандарт Электрон Связь

Мы молодая и активно развивающаяся компания в области поставок электронных компонентов. Мы поставляем электронные компоненты отечественного и импортного производства напрямую от производителей и с крупнейших складов мира.

Благодаря сотрудничеству с мировыми поставщиками мы осуществляем комплексные и плановые поставки широчайшего спектра электронных компонентов.

Собственная эффективная логистика и склад в обеспечивает надежную поставку продукции в точно указанные сроки по всей России.

Мы осуществляем техническую поддержку нашим клиентам и предпродажную проверку качества продукции. На все поставляемые продукты мы предоставляем гарантию .

Осуществляем поставки продукции под контролем ВП МО РФ на предприятия военно-промышленного комплекса России , а также работаем в рамках 275 ФЗ с открытием отдельных счетов в уполномоченном банке. Система менеджмента качества компании соответствует требованиям ГОСТ ISO 9001.

Минимальные сроки поставки, гибкие цены, неограниченный ассортимент и индивидуальный подход к клиентам являются основой для выстраивания долгосрочного и эффективного сотрудничества с предприятиями радиоэлектронной промышленности, предприятиями ВПК и научно-исследовательскими институтами России.

С нами вы становитесь еще успешнее!

Наши контакты:

Телефон: +7 812 627 14 35

Электронная почта: sales@st-electron.ru

Адрес: 198099, Санкт-Петербург,
Промышленная ул, дом № 19, литера Н,
помещение 100-Н Офис 331