

**MAXIM**

# SOT23, Single-Cell Li+ Battery Charger for Current-Limited Supply

**MAX1736**

## General Description

The MAX1736 is a simple, low-cost, single-cell lithium-ion (Li+) battery charger for small hand-held applications. When accompanied by a current-limited voltage source (such as a wall cube), the MAX1736 provides simple, accurate charging and termination control for single-cell Li+ batteries. The MAX1736EUT42 is preset to a 4.2V battery regulation voltage, while the MAX1736EUT41 is preset to 4.1V.

The MAX1736 initiates charging in one of four ways: battery insertion, charger power-up, battery voltage threshold, and by external manipulation of the EN pin. The device features an internal precharge current source that safely charges near-dead cells, as well as input-supply detection that shuts down the MAX1736 when the supply is removed to minimize battery current drain.

The MAX1736 accepts input voltages up to 22V, making it compatible with a wide range of input supplies. It has a single control input yet offers stand-alone and microprocessor-controlled operation. The MAX1736 is packaged in a small SOT23-6 package. An evaluation kit (EV kit) is available to reduce design time.

## Applications

Single-Cell Li+ Portable Applications  
Wireless Handsets  
Personal Digital Assistants  
Digital Cameras  
Small Hand-Held Equipment  
Self-Charging Battery Packs  
Cradle Chargers

## Typical Operating Circuit

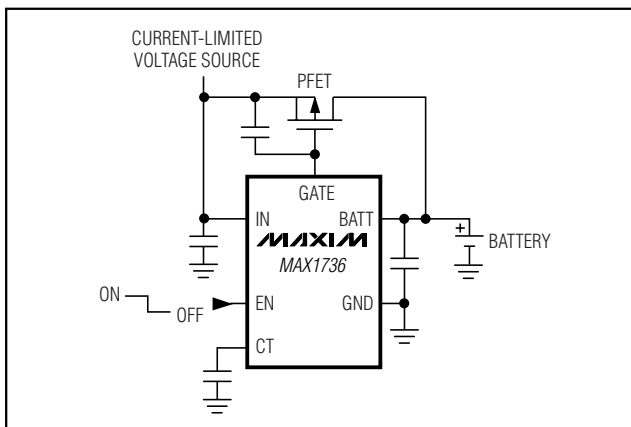

## Features

- ◆ Small 6-Pin SOT23 Package
- ◆ Stand-Alone or  $\mu$ P-Controlled Operation
- ◆ 0.5% Voltage Set-Point Accuracy
- ◆ Lowest Power Dissipation
- ◆ Low 4.7V min Input Voltage
- ◆ Top-Off Charging to Achieve Full Battery Capacity
- ◆ No Inductor Required
- ◆ Safely Precharges Near-Dead Cells
- ◆ Automatic Power-Down when Input Power Removed

## Ordering Information

PART	TEMP. RANGE	PIN-PACKAGE	SOT MARK
MAX1736EUT42-T	-40°C to +85°C	6 SOT23-6	AAHO
MAX1736EUT41-T	-40°C to +85°C	6 SOT23-6	AANC

**Note:** Requires special solder temperature profile described in the Absolute Maximum Ratings Section.

## Pin Configuration

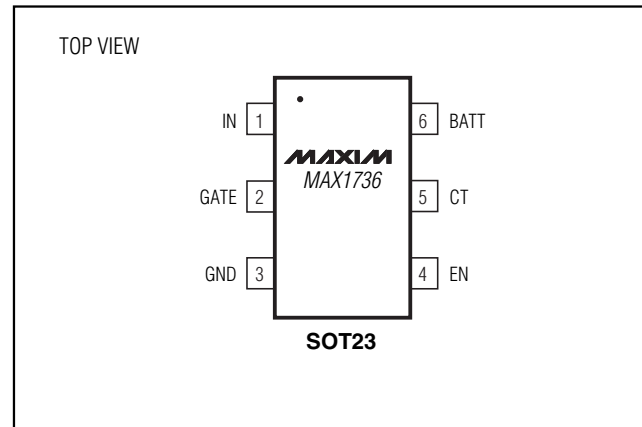
**MAXIM**

Maxim Integrated Products 1

For price, delivery, and to place orders, please contact Maxim Distribution at 1-888-629-4642, or visit Maxim's website at [www.maxim-ic.com](http://www.maxim-ic.com).

# SOT23, Single-Cell Li+ Battery Charger for Current-Limited Supply

## ABSOLUTE MAXIMUM RATINGS

IN, GATE to GND.....-0.3V to +26V  
 BATT, EN, CT to GND .....-0.3V to +6V  
 GATE to IN.....-6V to +0.3V  
 GATE Continuous Current.....-10mA to +10mA  
 Continuous Power Dissipation (T<sub>A</sub> = +70°C) (Note 1)  
 6-Pin SOT23 (derate 8.1mW/°C above +70°C).....0.65W

Operating Temperature Range .....-40°C to +85°C  
 Storage Temperature Range .....-65°C to +150°C  
 Maximum Junction Temperature .....+150°C  
 Lead Temperature (soldering, 10s) (Note 2) .....+300°C

**Note 1:** Thermal properties are specified with product mounted on PC board with one square-inch of copper area and still air.

**Note 2:** This device is constructed using a unique set of packaging techniques that impose a limit on the thermal profile the device can be exposed to during solder attach and rework. This limit permits only the use of the solder profiles recommended in the industry standard specification, IPC/JEDEC J-STD-020A, paragraph 7.6, Table 3 for the IR/VPR and Convection reflow. Pre-heating is required. Hand or wave soldering is not allowed.

Stresses beyond those listed under "Absolute Maximum Ratings" may cause permanent damage to the device. These are stress ratings only, and functional operation of the device at these or any other conditions beyond those indicated in the operational sections of the specifications is not implied. Exposure to absolute maximum rating conditions for extended periods may affect device reliability.

## ELECTRICAL CHARACTERISTICS

(V<sub>IN</sub> = 10V, V<sub>BATT</sub> = 4.2V for MAX1736EUT42 or 4.1V for MAX1736EUT41, T<sub>A</sub> = 0°C to +85°C. Typical values are at T<sub>A</sub> = +25°C, unless otherwise noted.) (Note 3)

PARAMETER	CONDITIONS	MIN	TYP	MAX	UNITS
Input Voltage (Note 4)	External P-MOSFET off	4.7		22	V
Fast-Charge BATT Qualification Threshold	BATT rising, transition from precharge to fast charge	2.4	2.5	2.65	V
Fast-Charge BATT Qualification Threshold Hysteresis			70		mV
BATT Regulation Voltage	MAX1736EUT42	4.179	4.20	4.221	V
	MAX1736EUT41	4.079	4.10	4.121	
BATT Removal Detection Threshold	BATT rising	4.875	5.0	5.1	V
BATT Removal Detection Threshold Hysteresis			125		mV
BATT Input Current, Input Power Removed	V <sub>IN</sub> ≤ V <sub>BATT</sub> - 0.3V		0.1	1	μA
BATT Input Current, Charger Disabled	EN = GND, V <sub>BATT</sub> = 0 to 5V		2	6	μA
BATT Input Current, When Charging			0.4	0.75	mA
Precharge Source Current	V <sub>BATT</sub> = 2V	3.5	6	8	mA
IN Input Current			0.25	1	mA
IN Detection Interval (Note 5)	C <sub>CT</sub> = 0.33μF		20		s
GATE Source/Sink Current		75	100	125	μA
GATE Drive Source Current at Battery Removal	V <sub>BATT</sub> = 5.1V	15	30	60	mA
Minimum BATT Bypass Capacitance (Note 6)		1.5			μF/A
EN Logic High Threshold		2			V
EN Logic Low Threshold				0.7	V
CT Pulldown Current		1.6	2	2.4	μA

# SOT23, Single-Cell Li+ Battery Charger for Current-Limited Supply

MAX1736

## ELECTRICAL CHARACTERISTICS (continued)

( $V_{IN} = 10V$ ,  $V_{BATT} = 4.2V$  for MAX1736EUT42 or 4.1V for MAX1736EUT41,  $T_A = 0^{\circ}C$  to  $+85^{\circ}C$ . Typical values are at  $T_A = +25^{\circ}C$ , unless otherwise noted.)

PARAMETER	CONDITIONS	MIN	TYP	MAX	UNITS
CT Pullup Current		-12	-10	-8	$\mu A$
Minimum On-Time	$C_{CT} = 0.33\mu F$		165		ms
Minimum Off-Time	$C_{CT} = 0.33\mu F$		33		ms
EN Pullup Resistance		175	350	725	$k\Omega$

## ELECTRICAL CHARACTERISTICS

( $V_{IN} = 10V$ ,  $V_{BATT} = 4.2V$  for MAX1736EUT42 or 4.1V for MAX1736EUT41,  $T_A = -40^{\circ}C$  to  $+85^{\circ}C$ , unless otherwise noted.) (Note 3)

PARAMETER	CONDITIONS	MIN	MAX	UNITS
Input Voltage (Note 4)	External P-MOSFET off	4.7	22	V
Fast-Charge BATT Qualification Threshold	BATT rising, transition from precharge to fast charge	2.4	2.65	V
BATT Regulation Voltage	MAX1736EUT42	4.158	4.242	V
	MAX1736EUT41	4.058	4.142	
BATT Removal Detection Threshold	BATT rising	4.85	5.125	V
BATT Input Current, Input Power Removed	$V_{IN} \leq V_{BATT} - 0.3V$		1	$\mu A$
BATT Input Current, Charger Disabled	EN = GND, $V_{BATT} = 0$ to 5V		6	$\mu A$
BATT Input Current, When Charging			0.75	mA
Precharge Source Current	$V_{BATT} = 2V$	3	8	mA
IN Input Current			1	mA
GATE Source/Sink Current		60	140	$\mu A$
GATE Drive Source Current at Battery Removal	$V_{BATT} = 5.1V$	10	90	mA
EN Logic High Threshold		2		V
EN Logic Low Threshold			0.7	V
CT Pulldown Current		1.5	2.5	$\mu A$
CT Pullup Current		-12	-8	$\mu A$
EN Pullup Resistance		170	725	$k\Omega$

**Note 3:** All devices are 100% production tested at  $T_A = +25^{\circ}C$ . Limits over the operating temperature range are guaranteed by design.

**Note 4:** The input voltage range is specified with the external PFET off. When charging, the PFET turns on and the input voltage (the output voltage of the constant-current power source) drops to very near the battery voltage. When the PFET is on,  $I_{IN}$  may be as low as 2.5V.

**Note 5:** Every 20s (for  $C_T = 0.33\mu F$ ) the MAX1736 turns off the external P-channel MOSFET and samples  $I_{IN}$  to determine if input power is present. If input power is removed, the charger shuts down.

**Note 6:** For design guidance, not tested.

# SOT23, Single-Cell Li+ Battery Charger for Current-Limited Supply

## Typical Operating Characteristics

( $T_A = +25^\circ\text{C}$ , unless otherwise noted.)

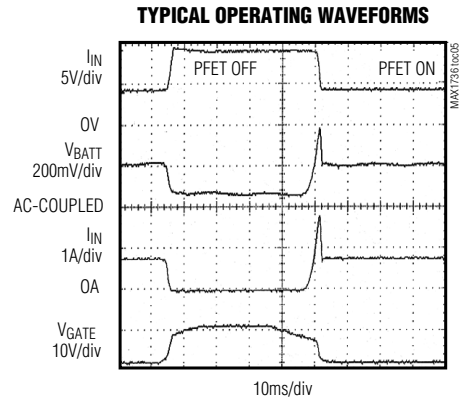
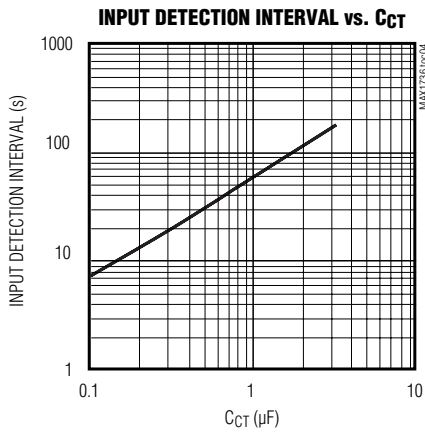
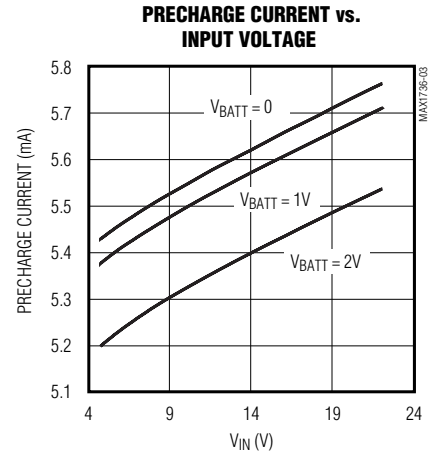
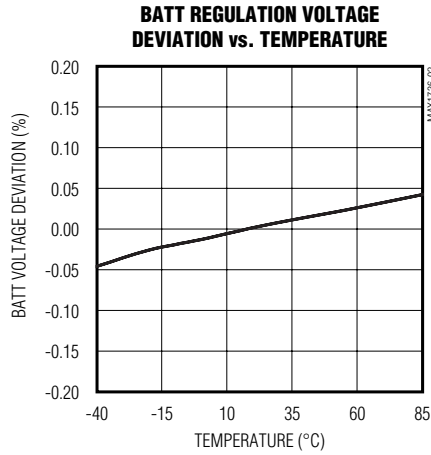
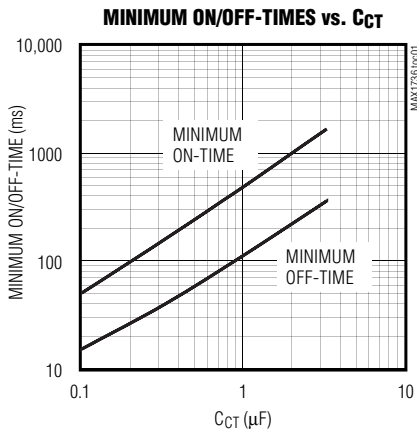

# SOT23, Single-Cell Li+ Battery Charger for Current-Limited Supply

## Pin Description

MAX1736

PIN	NAME	DESCRIPTION
1	IN	Input Voltage from Current-Limited Voltage Source (22V max). Bypass to GND with a 0.1 $\mu$ F capacitor. The charging current is set by the current limit of the external power supply.
2	GATE	Gate Drive for External PMOS Pass Element. The PMOS device should have a $V_{GS}$ threshold of 2.5V or less (see <i>Selecting External Components</i> ).
3	GND	Ground. Connect the battery's negative terminal to GND.
4	EN	Logic-Level Enable Input. Pull low to disable the MAX1736. EN is internally pulled up to $V_{BATT} + 100\text{mV}$ through 350k $\Omega$ , but draws no current from BATT.
5	CT	Charge Time Control. Sets the minimum on-time, minimum off-time, and the IN detection interval. Place a 0.33 $\mu$ F capacitor between CT and GND for most applications (see <i>Selecting External Components</i> ).
6	BATT	Cell Voltage Monitor Input, Precharge Current Output, and MAX1736 Power Source. Connect BATT to the positive terminal of a single Li+ cell. Bypass BATT with a capacitor to GND (1.5 $\mu$ F per amp of charge current).

## Detailed Description

The MAX1736 provides a simple, safe, low-cost method of charging a single-cell Li+ battery with nearly no heat generation. Combined with a current-limited voltage source, the MAX1736 provides precharge, fast-charge, and top-off-charge capabilities. After constant-current fast charge, top-off safely finishes charging the battery by pulse-width modulating charge current. The top-off on-time is kept below the electrochemical time constant of the cell. The key advantage of this method is that the charge circuit is small and generates minimal heat while providing a safe method of charging to ensure maximum cell life. Figure 1 shows the MAX1736 functional diagram.

### Precharge

To protect Li+ cells from damage that may occur if fast charged from a dead state, the MAX1736 precharges the Li+ cell with 6mA at the start of a charging cycle when the cell voltage is below 2.5V. As soon as the cell voltage reaches 2.5V, the MAX1736 begins fast charging.

### Fast Charge

In fast-charge mode, the MAX1736 turns on the external P-channel MOSFET. Charging current is set by the current limit of the external supply; **current is not regulated by the MAX1736**. The P-channel MOSFET is used only as a switch, not as a linear regulator. Therefore, the circuit's power dissipation is minimized, permitting rapid charge cycles with almost no heat generation. The external power supply should have a

specified current limit that matches the desired fast-charge current for the Li+ cell.

With the P-channel MOSFET on,  $V_{IN}$  will be nearly equal to  $V_{BATT}$ . To detect that an input supply is connected, the MAX1736 periodically turns the P-channel MOSFET off and checks the voltage at IN. During fast charge, this occurs once every input detection interval (20s with  $C_{CT} = 0.33\mu\text{F}$ ). During pulsed top-off, input detection occurs more frequently and is continuous when the MOSFET is off (see *Selecting External Components*).

### Pulsed Top-Off

When the battery approaches full charge, its instantaneous voltage reaches the BATT regulation voltage and pulsed top-off begins. The MAX1736 uses a hysteric algorithm with a minimum on- and off-time. Cell voltage is sampled with no charging current to minimize errors due to battery and cell protection resistance.

If the voltage is below the BATT regulation voltage, the P-channel MOSFET switches on for a minimum on-time. If, at the end of the minimum on-time, the cell voltage is still below the BATT regulation voltage, the switch remains on until the cell voltage reaches the BATT regulation voltage. At that point, the P-channel MOSFET then switches off for at least the minimum off-time. The minimum on-time is set by CT and should be set below the electrochemical time constant of the cell. A  $C_{CT}$  value of 0.33 $\mu$ F sets a minimum on-time of 165ms, which is adequate for most Li+ batteries.

# SOT23, Single-Cell Li+ Battery Charger for Current-Limited Supply

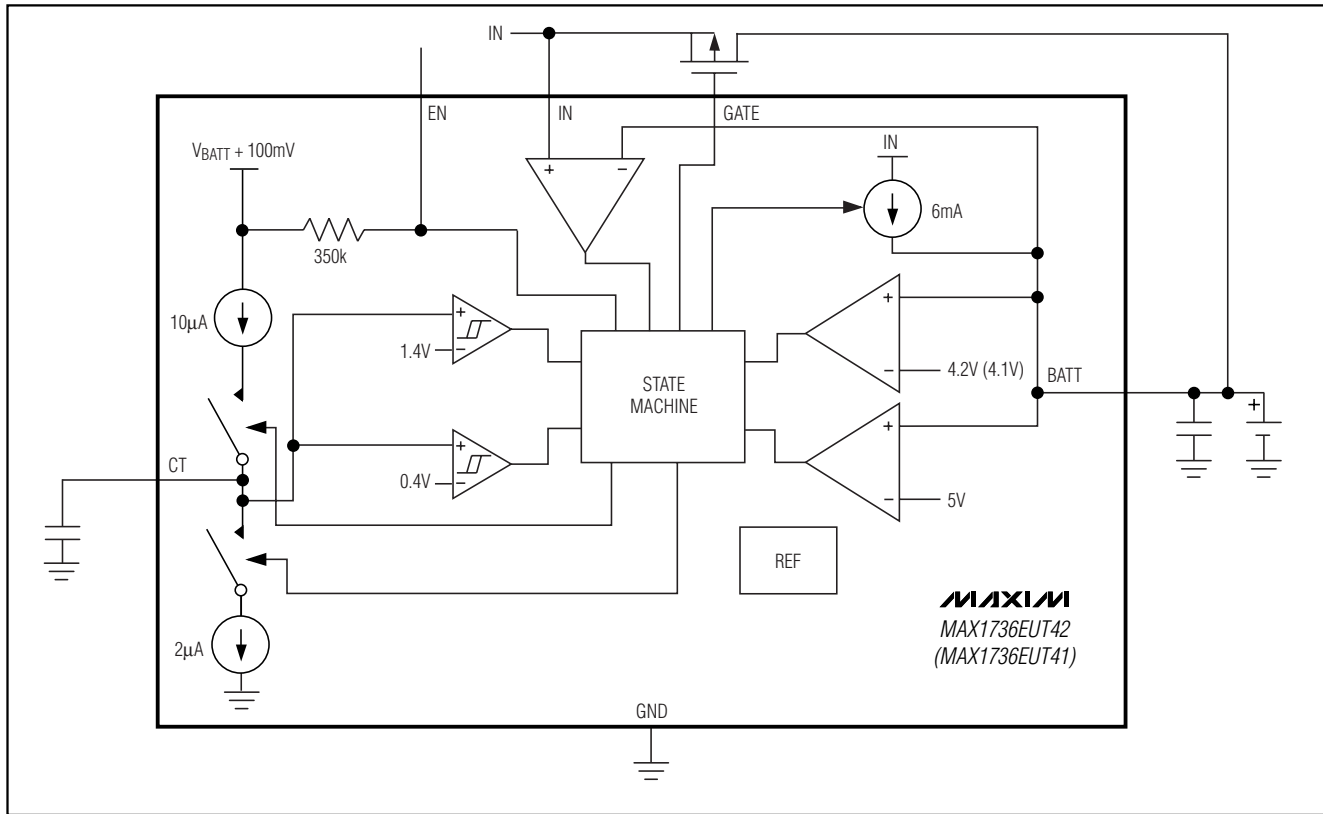

Figure 1. Functional Diagram

Once the switch turns off, it remains off for at least the minimum off-time. After the minimum off-time, the P-channel MOSFET turns on if the cell voltage is lower than the BATT regulation voltage. A  $C_{CT}$  value of 0.33µF sets a minimum off-time of 33ms.

At the beginning of the pulsed top-off state, charge current is modulated at approximately an 83% duty cycle. Toward the end of top-off, charge current stays off for long periods of time between single “on” pulses. During these final pulses, the instantaneous cell voltage may exceed the BATT regulation voltage by several hundred millivolts, but these pulses are orders of magnitude shorter than the electrochemical time constant of the Li+ cell and do no harm. Pulsed top-off charge ends when the cell voltage no longer falls below the BATT regulation voltage. Figure 2 shows the state machine.

## Selecting External Components

### Input Power Supply

One reason the MAX1736 Li+ charger is so compact and simple is that the charging current is set by the

external power source, not by the MAX1736. The P-channel MOSFET in Figure 3’s application circuit is either on or off, allowing the source to be directly connected to the cell or disconnected. Therefore, it is important to choose a power supply with the correct current limit for the cell to be charged. In most applications, this will be a small wall cube with an open-circuit output voltage of 5V to 12V, which is specified as “current limited” or “constant current.”

Some low-cost wall cubes may have poor transient characteristics. For these wall cubes, output current may exceed the specified current limit by several times when the load is quickly connected. The MAX1736 limits this current peak by controlling the slew rate of the P-channel MOSFET. See  $C_{CT}$  and  $C_{GATE}$  for more information.

### PMOS Switch

The P-channel MOSFET switches the current-limited source on and off. Because of the intentionally slow switching times and limited slew rate, the MAX1736 is not particular about the power FET it drives. Specifications to consider when choosing an appropriate

# SOT23, Single-Cell Li+ Battery Charger for Current-Limited Supply

MAX1736

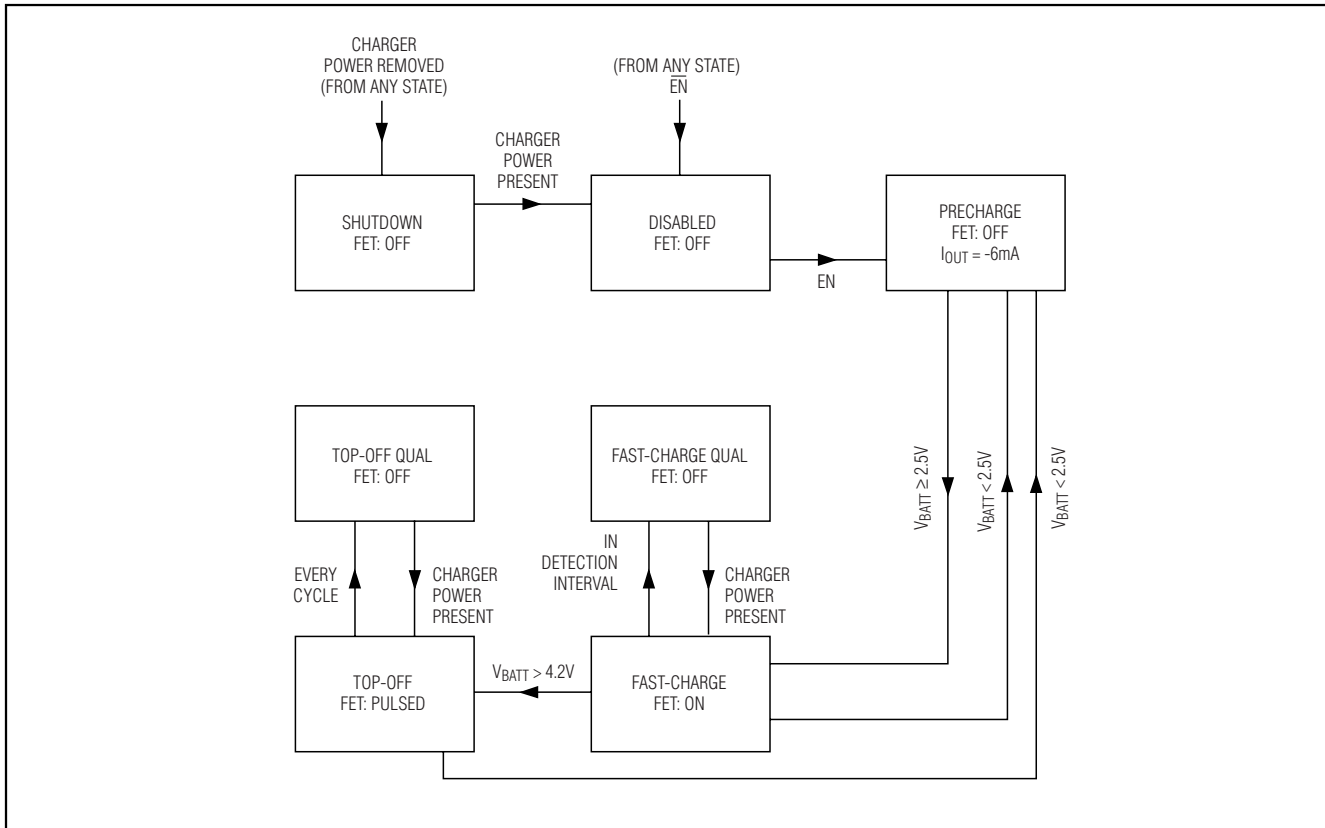

Figure 2. State Machine

FET are the minimum drain-source breakdown voltage and the minimum turn-on threshold voltage ( $V_{GS}$ ). Power dissipation during fast charge is approximately  $R_{DS(on)} \times I_{CHG}^2$ , where  $I_{CHG}$  is the current limit set by the input power source. The minimum breakdown voltage ( $BV_{DS}$ ) must typically be two times the wall cube's open-circuit voltage. An even larger margin may be necessary if the wall adapter has especially poor transient response. The MAX1736 can operate with input voltages up to 22V.

### BATT Capacitor

Bypass BATT with at least 1.5 $\mu$ F per amp of charge current. If the battery is removed while the P-channel MOSFET is on, a BATT voltage over 5V is quickly sensed, and the FET is immediately turned off. In applications where the cell is removable, very large capacitance values may increase transient currents when the cell is replaced. Therefore, BATT capacitance in excess of 100 $\mu$ F should be avoided. For best system performance with large output capacitance, at least

0.47 $\mu$ F of the total capacitance should be low-ESR ceramic.

### CCT and CGATE

Most applications will use the circuit of Figure 3 with  $C_{GATE} = 0.22\mu$ F,  $R_{GATE} = 100k\Omega$ , and  $C_{CT} = 0.33\mu$ F.

$C_{GATE}$ ,  $R_{GATE}$ , and the internal 100 $\mu$ A pull-up and pull-down current sources act to slow the switching of the P-channel MOSFET. This prevents a wall cube with poor transient response from subjecting  $V_{IN}$  to excessive voltage when the P-channel MOSFET turns off, and prevents excessive current into the battery when the P-channel MOSFET turns on. Excessive voltage at  $V_{IN}$  can potentially damage the IC, input capacitor, and the PMOS switch. Excessive current into the battery can cause errors in the termination process of the MAX1736 (by raising the instantaneous battery voltage) and may trip the battery's protection circuitry.

In applications utilizing a wall cube with poor transient response, increase the value of  $C_{GATE}$  as needed to

# SOT23, Single-Cell Li+ Battery Charger for Current-Limited Supply

further slow switching edges and prevent transient spikes.

C<sub>CT</sub> sets the minimum on-time and off-time according to the following equations:

$$t_{ON(MIN)} = 5 \times 10^5 \times C_{CT}$$

$$t_{OFF(MIN)} = 1 \times 10^5 \times C_{CT}$$

### Layout Guidelines

The MAX1736 controls the GATE slew rate; consequently, PC board layout is not as sensitive to noise as a high-frequency switching regulator. In addition, since cell voltage is sensed both during and between high-current pulses, the system is insensitive to ground errors. However, Maxim recommends maintaining large ground area and large traces for high-current paths. Refer to the MAX1736EVKIT for a recommended layout example.

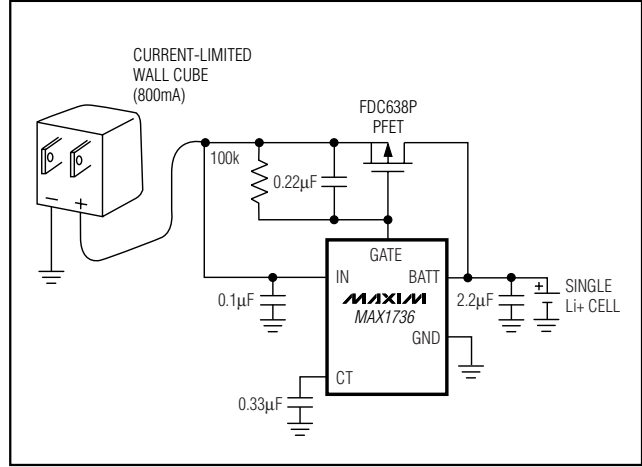
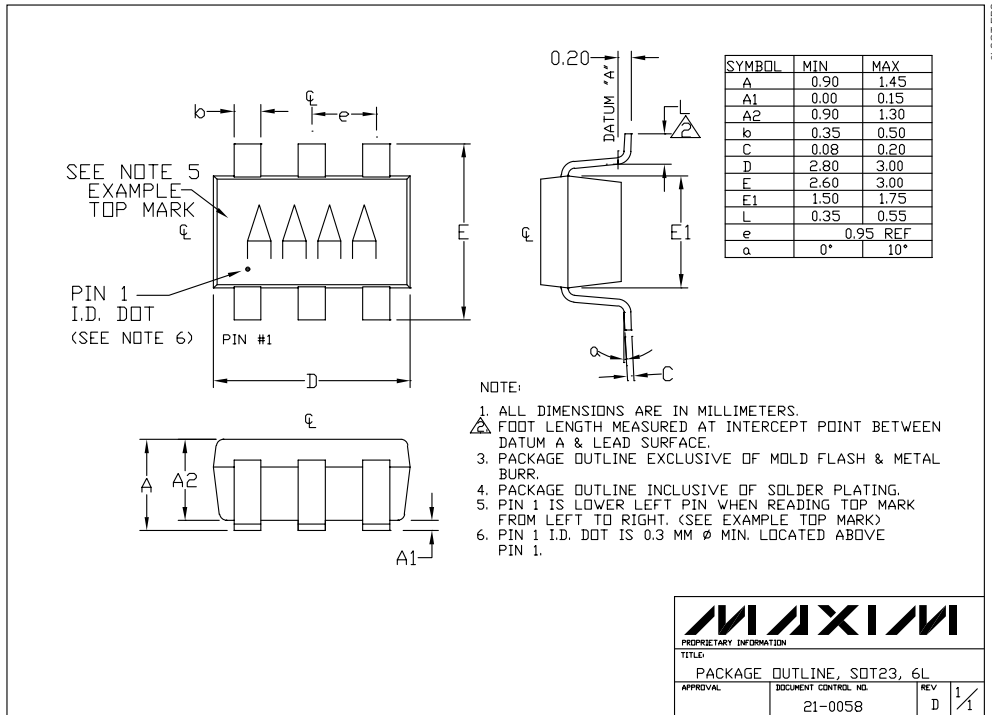

Figure 3. Simple Application Circuit

## Chip Information

TRANSISTOR COUNT: 1622

## Package Information



Maxim cannot assume responsibility for use of any circuitry other than circuitry entirely embodied in a Maxim product. No circuit patent licenses are implied. Maxim reserves the right to change the circuitry and specifications without notice at any time.

8 Maxim Integrated Products, 120 San Gabriel Drive, Sunnyvale, CA 94086 408-737-7600





## Стандарт Электрон Связь

Мы молодая и активно развивающаяся компания в области поставок электронных компонентов. Мы поставляем электронные компоненты отечественного и импортного производства напрямую от производителей и с крупнейших складов мира.

Благодаря сотрудничеству с мировыми поставщиками мы осуществляем комплексные и плановые поставки широчайшего спектра электронных компонентов.

Собственная эффективная логистика и склад в обеспечивает надежную поставку продукции в точно указанные сроки по всей России.

Мы осуществляем техническую поддержку нашим клиентам и предпродажную проверку качества продукции. На все поставляемые продукты мы предоставляем гарантию .

Осуществляем поставки продукции под контролем ВП МО РФ на предприятия военно-промышленного комплекса России , а также работаем в рамках 275 ФЗ с открытием отдельных счетов в уполномоченном банке. Система менеджмента качества компании соответствует требованиям ГОСТ ISO 9001.

Минимальные сроки поставки, гибкие цены, неограниченный ассортимент и индивидуальный подход к клиентам являются основой для выстраивания долгосрочного и эффективного сотрудничества с предприятиями радиоэлектронной промышленности, предприятиями ВПК и научно-исследовательскими институтами России.

С нами вы становитесь еще успешнее!

### Наши контакты:

**Телефон:** +7 812 627 14 35

**Электронная почта:** [sales@st-electron.ru](mailto:sales@st-electron.ru)

**Адрес:** 198099, Санкт-Петербург,  
Промышленная ул, дом № 19, литера Н,  
помещение 100-Н Офис 331