



LEOPARD IMAGING INC

Rev 1.1

LI-TX1-KIT-IMX185CS

Data Sheet

Key Features

- Compatible with Nvidia Jetson TX1
- MIPI interface
- Support up to three IMX185 cameras
- Sony Diagonal 8.58mm Type 1/1.9 CMOS Image Sensor IMX185LQJ
- Active pixels: 1937H x 1217V
- Length of the I-PEX cable: 300mm
- Support CS lens
- Provide customization services
- Weight: 78 g
- Part#: **LI-TX1-KIT-IMX185CS**



BOM

#	Items	QTY
1	LI-JTX1-MIPI-ADPT	1
2	LI-IMX185-MIPI-CS	1
3	FAW-1233-03 cable	1

Lens Spec

- Model: ES0522F.IR
- Focal length: 5.0 mm
- Aperture, F/#: 2.2
- Built in 650nm IR cut filter
- FOV (D/H/V): 102° / 90° / 50°
- TV Distortion: < -8%
- Mount Type: CS

Dimensions (LI-JTX1-MIPI-ADPT)

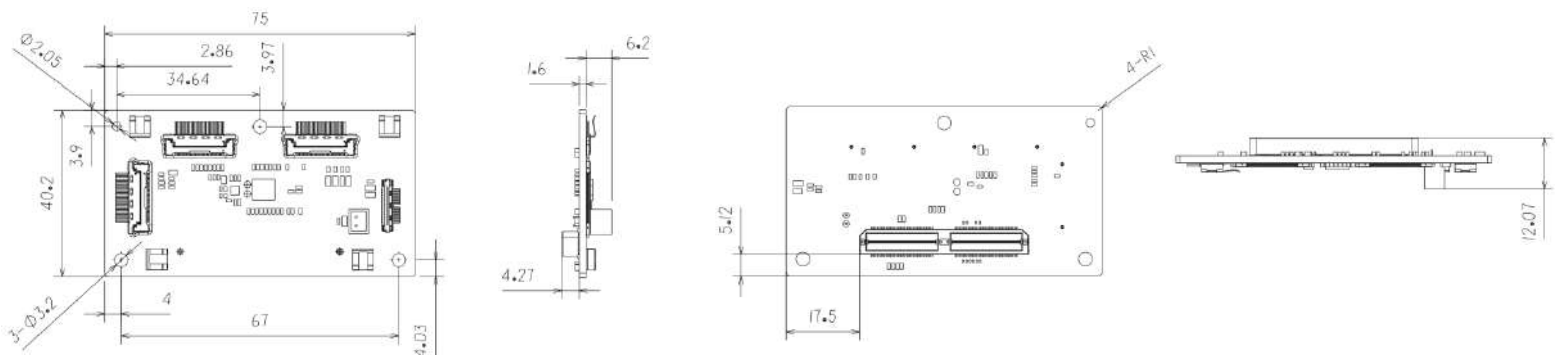

Leopard Imaging Inc.

1130 Cadillac Ct., Milpitas, CA 95035, USA
 Phone: +1-408-263-0988
 Fax: +1-408-217-1960
 Email: sales@leopardimaging.com
 Website: www.leopardimaging.com
 www.leopard-security.com

Dimensions (LI-IMX185-MIPI-CS)

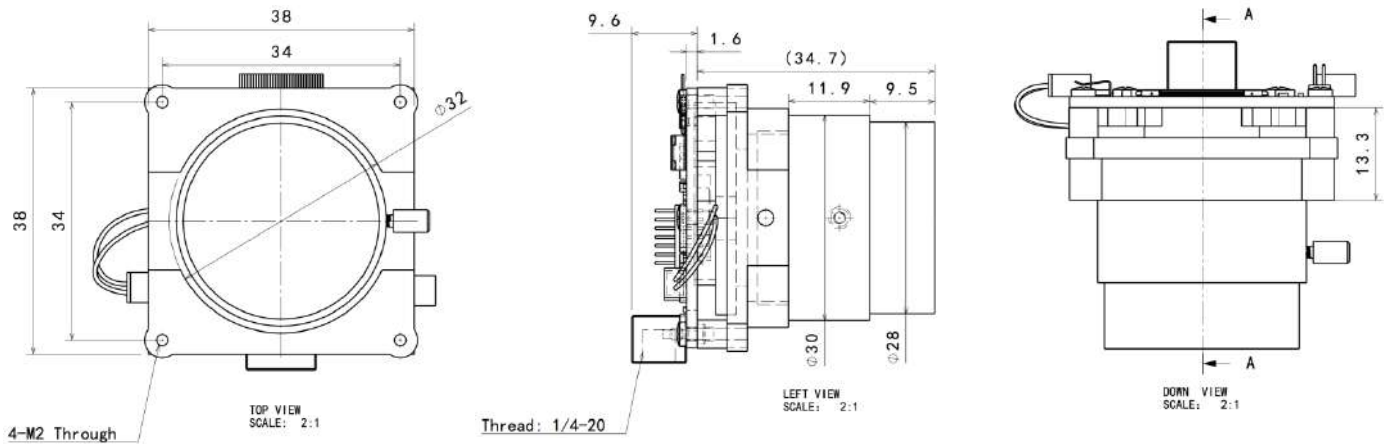

Dimensions (FAW-1233-03)

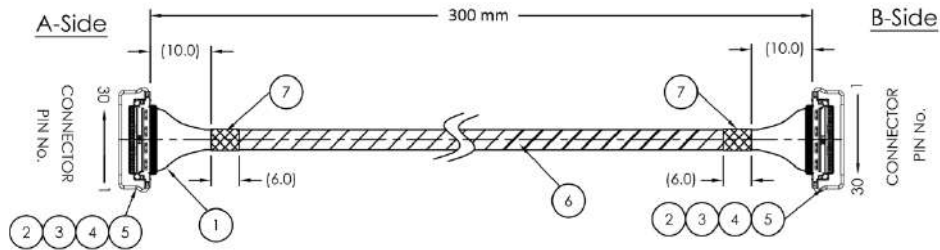

Work on Nvidia Jetson TX1



Leopard Imaging Inc.

1130 Cadillac Ct., Milpitas, CA 95035, USA
 Phone: +1-408-263-0988
 Fax: +1-408-217-1960
 Email: sales@leopardimaging.com
 Website: www.leopardimaging.com
 www.leopard-security.com

LI-JTX1-MIPI-ADPT



Interfaces

Interface J1

- Part#: 20525-030E-02C
- Number of Positions: 30
- Pitch: 0.4mm
- Mating I-PEX cable: FAW-1233-03 (300mm)

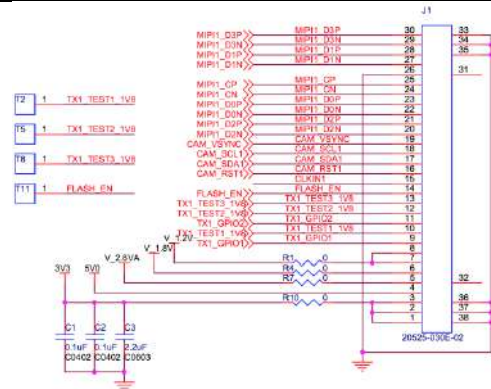

Interface J2

- Part#: 20525-030E-02C
- Number of Positions: 30
- Pitch: 0.4mm
- Mating I-PEX cable: FAW-1233-03 (300mm)

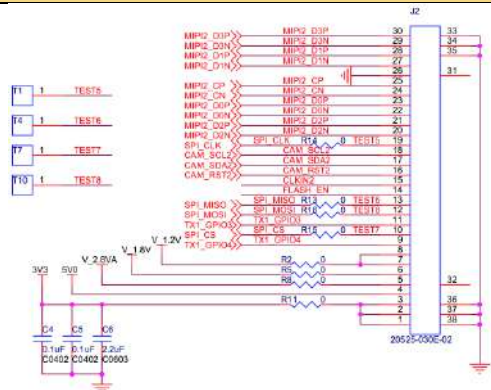

Interface J3

- Part#: 20525-030E-02C
- Number of Positions: 30
- Pitch: 0.4mm
- Mating I-PEX cable: FAW-1233-03 (300mm)

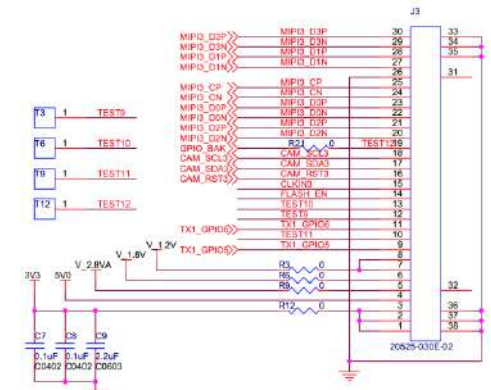

1130 Cadillac Ct., Milpitas, CA 95035, USA
 Phone: +1-408-263-0988
 Fax: +1-408-217-1960
 Email: sales@leopardimaging.com
 Website: www.leopardimaging.com
 www.leopard-security.com



Leopard Imaging Inc.

Interface J10

- Part#: QTH-060-01-L-D-A
- Number of Positions: 120
- Number of Rows: 2
- Pitch: 0.5 mm

Vertical Mating connector of Jetson TX1 J22

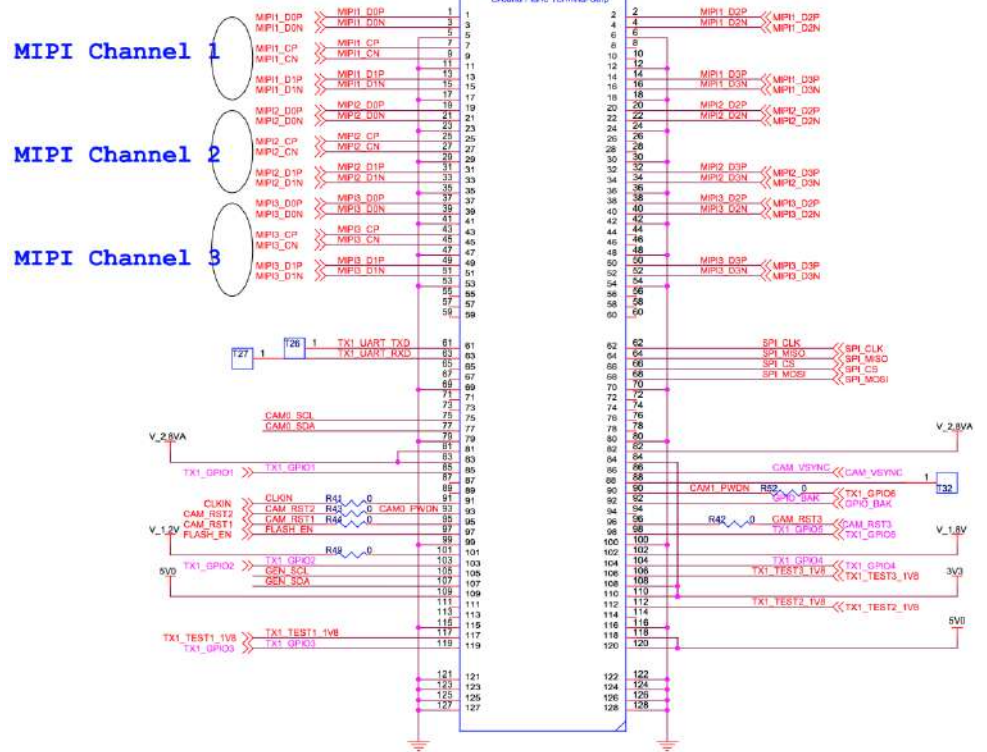

Leopard Imaging Inc.

1130 Cadillac Ct., Milpitas, CA 95035, USA
 Phone: +1-408-263-0988
 Fax: +1-408-217-1960
 Email: sales@leopardimaging.com
 Website: www.leopardimaging.com
 www.leopard-security.com

LI-IMX185-MIPI-CS

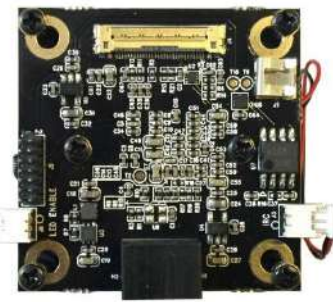

Camera Spec	
Image Sensor	Sony Diagonal 8.58 mm (Type 1/1.9) Solid-state Image Sensor IMX185
Optical format	1/1.9"
Number of active pixels	1952 (H) x 1243 (V)
Pixel size	3.75um (H) x 3.75um (V)
Color or Mono	Color
Interface	MIPI interface
Lens mount	CS
IR switcher	Support
Weight	58 g
Interfaces	
Interface J2:	<ul style="list-style-type: none"> Part#: 20525-030E-02C Number of Positions: 30 Pitch: 0.4mm Mating I-PEX cable: FAW-1233-03 (300mm)
Interface J3:	<ul style="list-style-type: none"> Part#: 1734829-2 Number of Positions: 2 Pitch: 1.25mm
Interface J5:	<ul style="list-style-type: none"> Part#: 1734829-2 Number of Positions: 2 Pitch: 1.25mm



Leopard Imaging Inc.

1130 Cadillac Ct., Milpitas, CA 95035, USA
 Phone: +1-408-263-0988
 Fax: +1-408-217-1960
 Email: sales@leopardimaging.com
 Website: www.leopardimaging.com
 www.leopard-security.com

Absolute Maximum Ratings

Item	Symbol	Min.	Max.	Unit	Remarks
Supply voltage (analog 3.3 V)	AV _{DD}	-0.3	4.0	V	
Supply voltage (digital 1.8 V)	OV _{DD}	-0.3	3.3	V	
Supply voltage (digital 1.2 V)	DV _{DD}	-0.3	2.0	V	
Input voltage	VI	-0.3	OV _{DD} + 0.3	V	Not exceed 3.3 V
Output voltage	VO	-0.3	OV _{DD} + 0.3	V	Not exceed 3.3 V
Guaranteed operating temperature	Topr	-30	+75	°C	
Storage guarantee temperature	Tstg	-40	+80	°C	
Performance guarantee temperature	Tspec	-10	+60	°C	

Recommended Operating Conditions

Item	Symbol	Min.	Typ.	Max.	Unit
Supply voltage (analog 3.3 V)	AV _{DD}	3.15	3.3	3.45	V
Supply voltage (digital 1.8 V)	OV _{DD}	1.7	1.8	1.9	V
Supply voltage (digital 1.2 V)	DV _{DD}	1.1	1.2	1.3	V

Spectral Sensitivity Characteristics

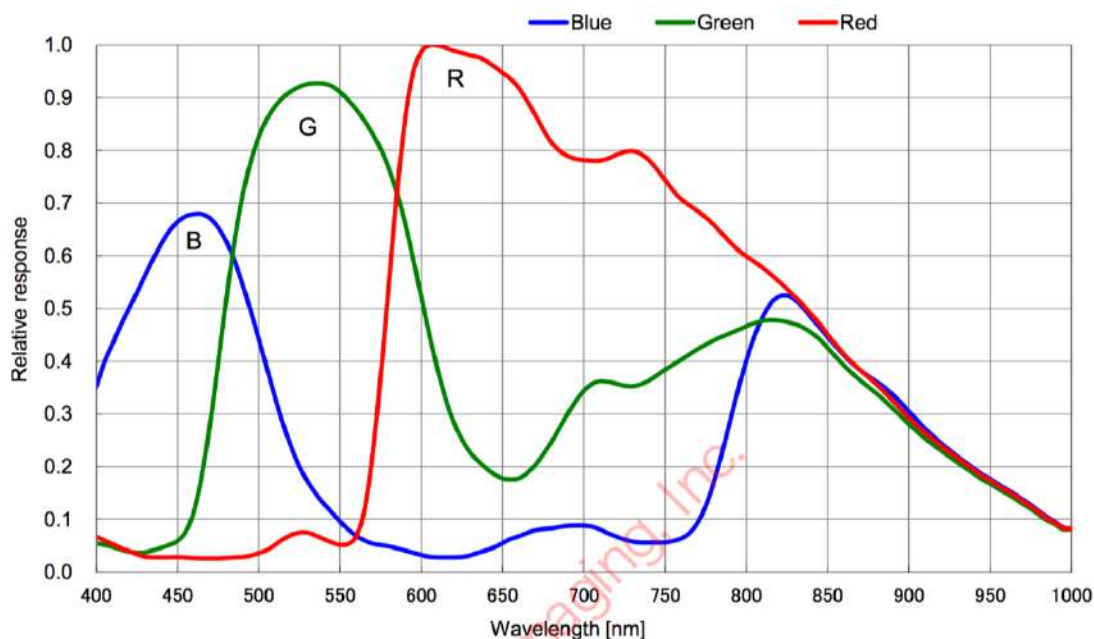

DC Characteristics

Item	Pins	Symbol	Conditions	Min.	Typ.	Max.	Unit
Supply voltage	Analog	V _{DDHx}	AV _{DD}	3.15	3.30	3.45	V
	Digital	V _{DDMx}	OV _{DD}	1.70	1.80	1.90	V
	Digital	V _{DDLx}	DV _{DD}	1.10	1.20	1.30	V
Digital input voltage	XHS XVS XCLR INCK XMASTER OMODE SCK/SCL SDI/SDA XCE	VIH	XVS/XHS in slave mode	0.8 × OV _{DD}	—	—	V
		VIL		—	—	0.2 × OV _{DD}	V
Digital output voltage	DOP [11:0] DOM [11:0] DCKP DCKM	VCM	Low voltage LVDS	—	OV _{DD} /2	—	V
		VOD	Low voltage LVDS (Termination resistance 100 Ω)	100	150	200	mV
	XHS XVS SDO	VOH	XVS/XHS in master mode	OV _{DD} -0.4	—	—	V
		VOL		—	—	0.4	V

Power Consumption

Item	Pins	Symbol	Typ.		Max.		Unit
			Standard luminous intensity	Saturated luminous intensity	Standard luminous intensity	Saturated luminous intensity	
Operating current CSI-2 serial output 4 Lane 12 bit, 60 frame/s 1080p-HD mode	V _{DDH}	IAV _{DD}	88	88	113	113	mA
	V _{DDM}	IOV _{DD}	2	2	4	4	mA
	V _{DDL}	IDV _{DD}	110	130	150	190	mA
Standby current	V _{DDH}	IAV _{DD_STB}	—	—	0.2		mA
	V _{DDM}	IOV _{DD_STB}	—	—	0.1		mA
	V _{DDL}	IDV _{DD_STB}	—	—	7.0		mA

Operating current:

(Typical value condition) : Supply voltage 3.3 V / 1.8 V / 1.2 V, T_j = 25 °C

(Maximum value condition) : Supply voltage 3.45 V / 1.9 V / 1.3 V, worst state of internal circuit operating current consumption, T_j = 60 °C

Standby (Maximum value condition) : Supply voltage 3.45 V / 1.9 V / 1.3 V, T_j = 60 °C, INCK = 0 V

Standard luminous intensity: luminous intensity at standard imaging condition I

Saturated luminous intensity: luminous intensity when the sensor is saturated.



Leopard Imaging Inc.

1130 Cadillac Ct., Milpitas, CA 95035, USA

Phone: +1-408-263-0988

Fax: +1-408-217-1960

Email: sales@leopardimaging.com

Website: www.leopardimaging.com

www.leopard-security.com

AC Specification

INCK

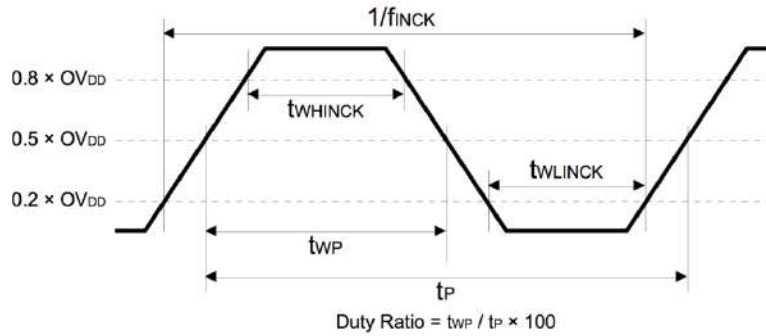

Item	Symbol	Min.	Typ.	Max.	Unit	Remarks
INCK clock frequency	f_{INCK}	$f_{INCK} \times 0.96$	f_{INCK}	$f_{INCK} \times 1.02$	MHz	$f_{INCK} = 27 \text{ MHz}, 54 \text{ MHz}, 37.125 \text{ MHz}, 74.25 \text{ MHz}$
INCK Low level width	t_{WLINCK}	4	—	—	ns	$f_{INCK} = 27 \text{ MHz}, 54 \text{ MHz}, 37.125 \text{ MHz}, 74.25 \text{ MHz}$
INCK High level width	t_{WHINCK}	4	—	—	ns	$f_{INCK} = 27 \text{ MHz}, 54 \text{ MHz}, 37.125 \text{ MHz}, 74.25 \text{ MHz}$
INCK clock duty	—	45.0	50.0	55.0	%	Define with $0.5 \times OV_{DD}$

*The INCK fluctuation affects the frame rate.

XHS, XVS Input Characteristics In Slave Mode (XMASTER pin = High)

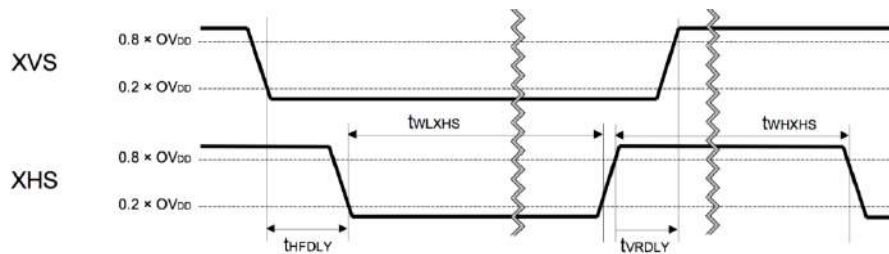

Item	Symbol	Min.	Typ.	Max.	Unit	Remarks
XHS Low level pulse width	t_{WLXHS}	$4 / f_{INCK}$	—	—	ns	
XHS High level pulse width	t_{WHXHS}	$4 / f_{INCK}$	—	—	ns	
XVS-XHS fall width	t_{HFDLY}	$1 / f_{INCK}$	—	—	ns	
XHS-XVS rise width	t_{VRDLY}	$1 / f_{INCK}$	—	—	ns	



Leopard Imaging Inc.

1130 Cadillac Ct., Milpitas, CA 95035, USA
 Phone: +1-408-263-0988
 Fax: +1-408-217-1960
 Email: sales@leopardimaging.com
 Website: www.leopardimaging.com
 www.leopard-security.com

I²C Communication

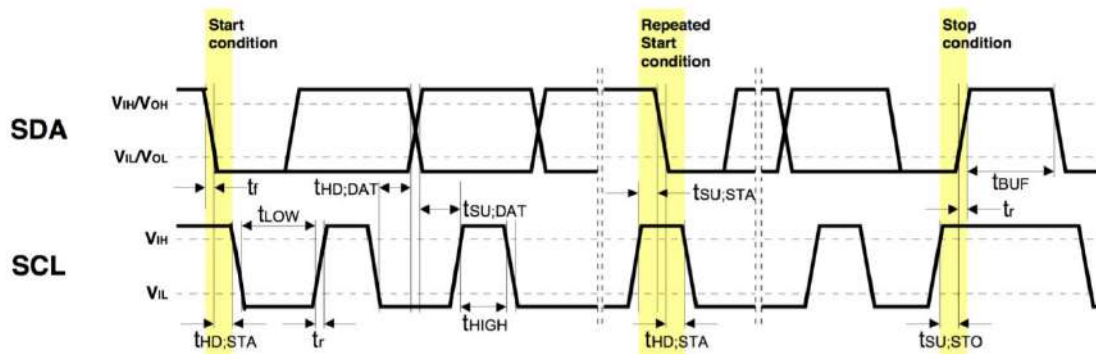

I²C Specification

Item	Symbol	Min.	Typ.	Max.	Unit	Remarks
Low level input voltage	V_{IL}	-0.3	—	$0.3 \times OV_{DD}$	V	
High level input voltage	V_{IH}	$0.7 \times OV_{DD}$	—	1.9	V	
Low level output voltage	V_{OL}	0	—	$0.2 \times OV_{DD}$	V	$OV_{DD} < 2\text{ V}$, Sink 3 mA
High level output voltage	V_{OH}	$0.8 \times OV_{DD}$	—	—	V	
Output fall time	t_{of}	—	—	250	ns	Load 10 pF – 400 pF, $0.7 \times OV_{DD} - 0.3 \times OV_{DD}$
Input current	i_i	-10	—	10	μA	$0.1 \times OV_{DD} - 0.9 \times OV_{DD}$
Capacitance for SCK (/SCL) , SDI (/SDA)	C_i	—	—	10	pF	

I²C AC Characteristics

Item	Symbol	Min.	Typ.	Max.	Unit
SCL clock frequency	f_{SCL}	0	—	400	kHz
Hold time (Start Condition)	t_{HDSTA}	0.6	—	—	μs
Low period of the SCL clock	t_{LOW}	1.3	—	—	μs
High period of the SCL clock	t_{HIGH}	0.6	—	—	μs
Set-up time (Repeated Start Condition)	t_{SUSTA}	0.6	—	—	μs
Data hold time	t_{HDDAT}	0	—	0.9	μs
Data set-up time	t_{SUDAT}	100	—	—	ns
Rise time of both SDA and SCL signals	t_R	—	—	300	ns
Fall time of both SDA and SCL signals	t_F	—	—	300	ns
Set-up time (Stop Condition)	t_{SUSTO}	0.6	—	—	μs
Bus free time between a Stop and Start Condition	t_{BUF}	1.3	—	—	μs



Leopard Imaging Inc.

1130 Cadillac Ct., Milpitas, CA 95035, USA
 Phone: +1-408-263-0988
 Fax: +1-408-217-1960
 Email: sales@leopardimaging.com
 Website: www.leopardimaging.com
 www.leopard-security.com

Power-on Sequence

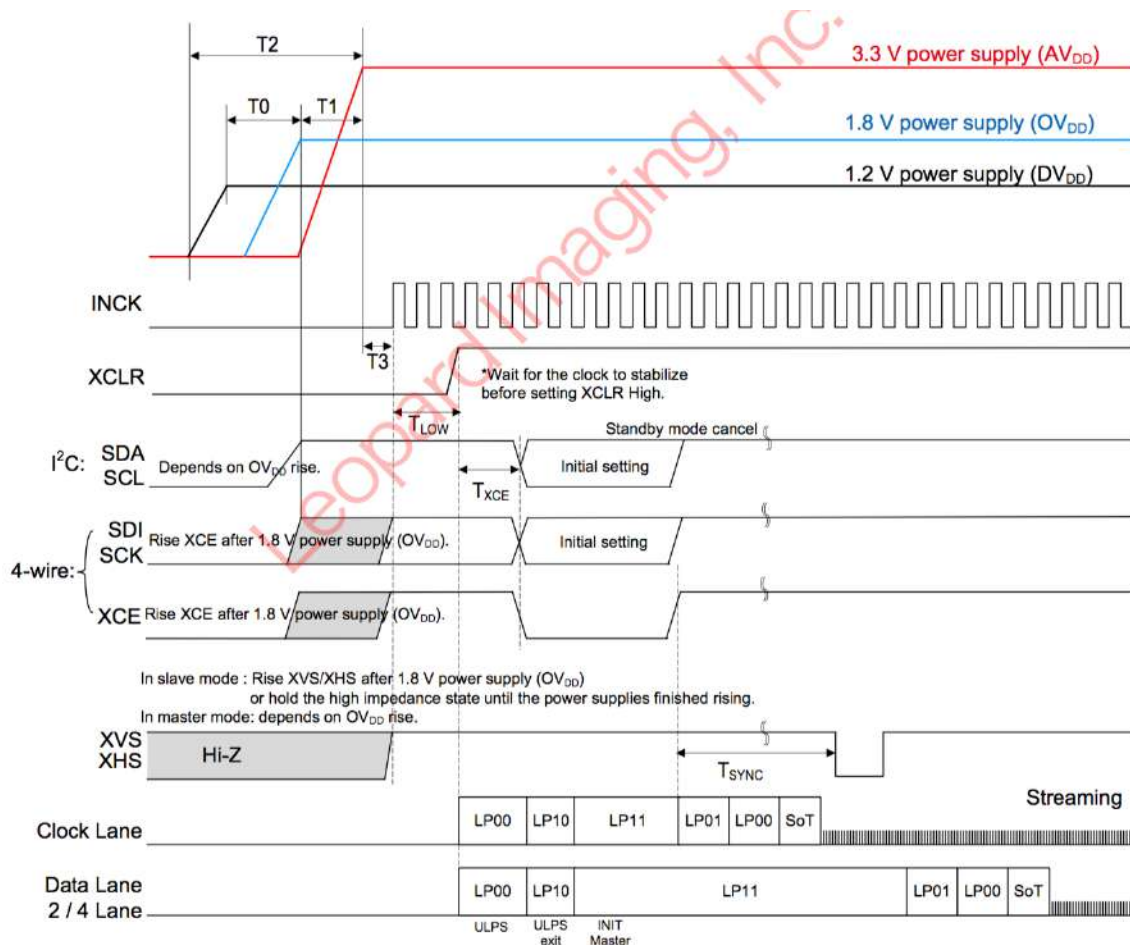

Item	Symbol	Min.	Max.	Unit
1.2 V power supply rising → 1.8 V power supply rising	T ₀	0	—	ns
1.8 V power supply rising → 3.3 V power supply rising	T ₁	0	—	ns
Rising time of all power supply	T ₂	—	200	ms
All power supply rising → External input time of INCK	T ₃	0	—	ns
INCK active → Clear OFF	T _{LOW}	500	—	ns
Clear OFF → Communication start	T _{XCE}	20	—	μs
Standby OFF (communication) → External input XHS, XVS (slave mode only)	T _{SYNC}	20	—	ms



Leopard Imaging Inc.

1130 Cadillac Ct., Milpitas, CA 95035, USA
 Phone: +1-408-263-0988
 Fax: +1-408-217-1960
 Email: sales@leopardimaging.com
 Website: www.leopardimaging.com
 www.leopard-security.com

Power-off Sequence

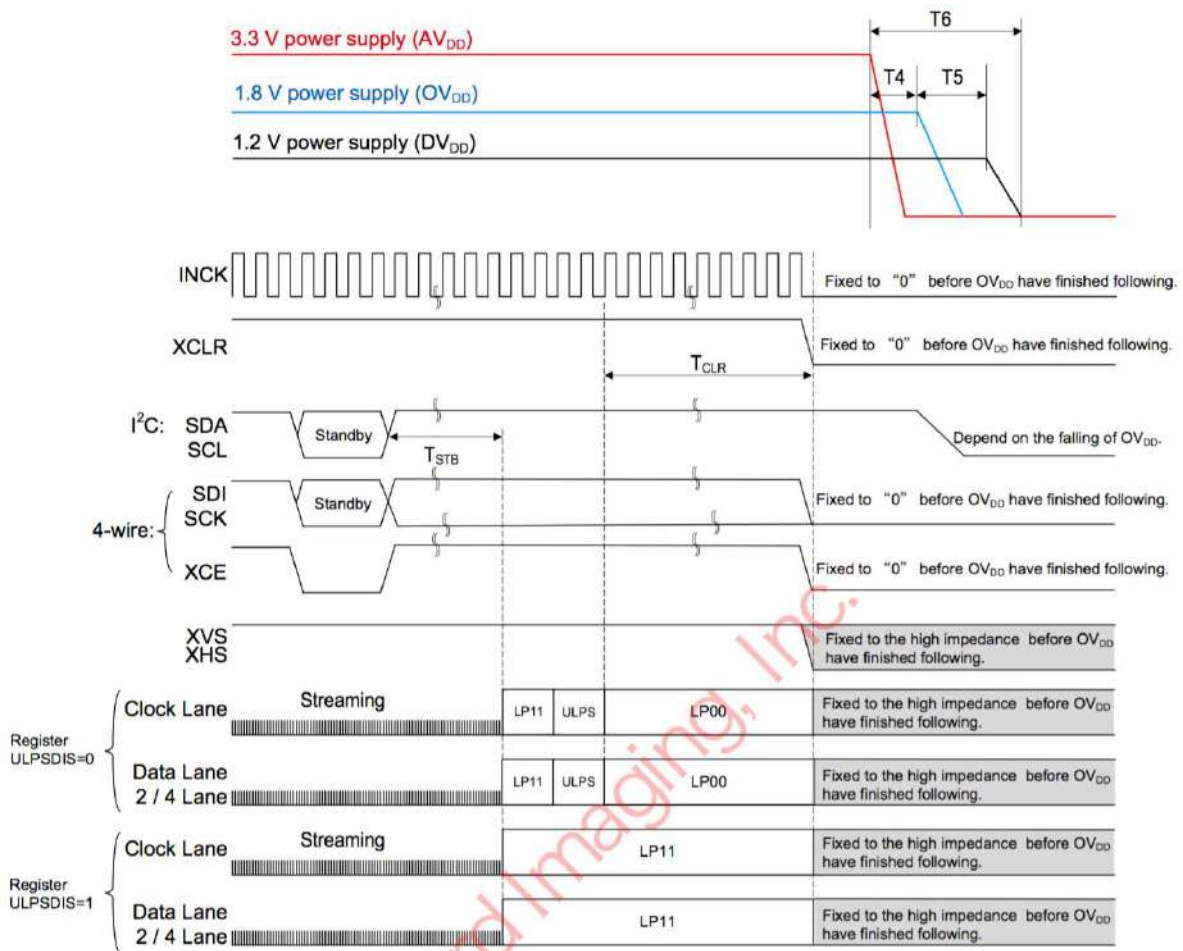

Item	Symbol	Min.	Max.	Unit
Standby ON (communication) → LP11 mode start	T _{STB}	Until FE		—
LP00 → XCLR falling (ULPSDIS = 0)	T _{CLR}	128	—	cycle
3.3 V power shut down → 1.8 V power shut down	T ₄	0	—	ns
1.8 V power shut down → 1.2 V power shut down	T ₅	0	—	ns
Shut down time of all power supply.	T ₆	—	200	ms



Optical dimension

◆ Image size (recommended recording pixels)

All-pixel scan : diagonal 8.49mm (type 1/1.9)

1080p-HD : diagonal 8.26mm (type 1/1.9)

◆ Number of recommended recording pixels

All-pixel scan : 1920 (H) × 1200 (V) approx. 2.31 M pixels

1080p-HD : 1920 (H) × 1080 (V) approx. 2.07 M pixels

◆ Unit cell size

3.75 μm (H) × 3.75 μm (V)

◆ Recommended eye relief compensation distance : - 30mm to -∞

Inc



Leopard Imaging Inc.

1130 Cadillac Ct., Milpitas, CA 95035, USA
Phone: +1-408-263-0988
Fax: +1-408-217-1960
Email: sales@leopardimaging.com
Website: www.leopardimaging.com
www.leopard-security.com



Стандарт Электрон Связь

Мы молодая и активно развивающаяся компания в области поставок электронных компонентов. Мы поставляем электронные компоненты отечественного и импортного производства напрямую от производителей и с крупнейших складов мира.

Благодаря сотрудничеству с мировыми поставщиками мы осуществляем комплексные и плановые поставки широчайшего спектра электронных компонентов.

Собственная эффективная логистика и склад в обеспечивает надежную поставку продукции в точно указанные сроки по всей России.

Мы осуществляем техническую поддержку нашим клиентам и предпродажную проверку качества продукции. На все поставляемые продукты мы предоставляем гарантию .

Осуществляем поставки продукции под контролем ВП МО РФ на предприятия военно-промышленного комплекса России , а также работаем в рамках 275 ФЗ с открытием отдельных счетов в уполномоченном банке. Система менеджмента качества компании соответствует требованиям ГОСТ ISO 9001.

Минимальные сроки поставки, гибкие цены, неограниченный ассортимент и индивидуальный подход к клиентам являются основой для выстраивания долгосрочного и эффективного сотрудничества с предприятиями радиоэлектронной промышленности, предприятиями ВПК и научно-исследовательскими институтами России.

С нами вы становитесь еще успешнее!

Наши контакты:

Телефон: +7 812 627 14 35

Электронная почта: sales@st-electron.ru

Адрес: 198099, Санкт-Петербург,
Промышленная ул, дом № 19, литера Н,
помещение 100-Н Офис 331