



Is Now Part of



**ON Semiconductor®**

To learn more about ON Semiconductor, please visit our website at  
[www.onsemi.com](http://www.onsemi.com)

Please note: As part of the Fairchild Semiconductor integration, some of the Fairchild orderable part numbers will need to change in order to meet ON Semiconductor's system requirements. Since the ON Semiconductor product management systems do not have the ability to manage part nomenclature that utilizes an underscore (\_), the underscore (\_) in the Fairchild part numbers will be changed to a dash (-). This document may contain device numbers with an underscore (\_). Please check the ON Semiconductor website to verify the updated device numbers. The most current and up-to-date ordering information can be found at [www.onsemi.com](http://www.onsemi.com). Please email any questions regarding the system integration to [Fairchild\\_questions@onsemi.com](mailto:Fairchild_questions@onsemi.com).

ON Semiconductor and the ON Semiconductor logo are trademarks of Semiconductor Components Industries, LLC dba ON Semiconductor or its subsidiaries in the United States and/or other countries. ON Semiconductor owns the rights to a number of patents, trademarks, copyrights, trade secrets, and other intellectual property. A listing of ON Semiconductor's product/patent coverage may be accessed at [www.onsemi.com/site/pdf/Patent-Marking.pdf](http://www.onsemi.com/site/pdf/Patent-Marking.pdf). ON Semiconductor reserves the right to make changes without further notice to any products herein. ON Semiconductor makes no warranty, representation or guarantee regarding the suitability of its products for any particular purpose, nor does ON Semiconductor assume any liability arising out of the application or use of any product or circuit, and specifically disclaims any and all liability, including without limitation special, consequential or incidental damages. Buyer is responsible for its products and applications using ON Semiconductor products, including compliance with all laws, regulations and safety requirements or standards, regardless of any support or applications information provided by ON Semiconductor. "Typical" parameters which may be provided in ON Semiconductor data sheets and/or specifications can and do vary in different applications and actual performance may vary over time. All operating parameters, including "Typicals" must be validated for each customer application by customer's technical experts. ON Semiconductor does not convey any license under its patent rights nor the rights of others. ON Semiconductor products are not designed, intended, or authorized for use as a critical component in life support systems or any FDA Class 3 medical devices or medical devices with a same or similar classification in a foreign jurisdiction or any devices intended for implantation in the human body. Should Buyer purchase or use ON Semiconductor products for any such unintended or unauthorized application, Buyer shall indemnify and hold ON Semiconductor and its officers, employees, subsidiaries, affiliates, and distributors harmless against all claims, costs, damages, and expenses, and reasonable attorney fees arising out of, directly or indirectly, any claim of personal injury or death associated with such unintended or unauthorized use, even if such claim alleges that ON Semiconductor was negligent regarding the design or manufacture of the part. ON Semiconductor is an Equal Opportunity/Affirmative Action Employer. This literature is subject to all applicable copyright laws and is not for resale in any manner.

# FSFR2100 — Fairchild Power Switch (FPS™) for Half-Bridge Resonant Converters

## Features

- Variable Frequency Control with 50% Duty Cycle for Half-bridge Resonant Converter Topology
- High Efficiency through Zero Voltage Switching (ZVS)
- Internal SuperFET™s with Fast-Recovery Type Body Diode ( $t_{rr}=120$  ns)
- Fixed Dead Time (350 ns) Optimized for MOSFETs
- Up to 300kHz Operating Frequency
- Pulse Skipping for Frequency Limit (Programmable) at Light-Load Condition
- Remote On/Off Control Using Control Pin
- Protection Functions: Over-Voltage Protection (OVP), Over-Load Protection (OLP), Over-Current Protection (OCP), Abnormal Over-Current Protection (AOCP), Internal Thermal Shutdown (TSD)

## Applications

- PDP and LCD TVs
- Desktop PCs and Servers
- Adapters
- Telecom Power Supplies
- Audio Power Supplies

## Description

The FSFR2100 is a highly integrated power switch designed for high-efficiency half-bridge resonant converters. Offering everything necessary to build a reliable and robust resonant converter, the FSFR2100 simplifies designs and improves productivity, while improving performance. The FSFR2100 combines power MOSFETs with fast-recovery type body diodes, a high-side gate-drive circuit, an accurate current controlled oscillator, frequency limit circuit, soft-start, and built-in protection functions. The high-side gate-drive circuit has a common-mode noise cancellation capability, which guarantees stable operation with excellent noise immunity. The fast-recovery body diode of the MOSFETs improves reliability against abnormal operation conditions, while minimizing the effect of the reverse recovery. Using the zero-voltage-switching (ZVS) technique dramatically reduces the switching losses and efficiency is significantly improved. The ZVS also reduces the switching noise noticeably, which allows a small-sized Electromagnetic Interference (EMI) filter.

The FSFR2100 can be applied to various resonant converter topologies, such as: series resonant, parallel resonant, and LLC resonant converters.

## Related Resources

- [AN-4151 — Half-Bridge LLC Resonant Converter Design Using FSFR2100 Fairchild Power Switch \(FPS™\)](#)
- [Evaluation Board: FEBFSFR2100\\_D015v1](#)

## Ordering Information

Part Number	Package	Operating Junction Temperature	$R_{DS(ON\_MAX)}$	Maximum Output Power without Heatsink ( $V_{IN}=350\sim400$ V) <sup>(1,2)</sup>	Maximum Output Power with Heatsink ( $V_{IN}=350\sim400$ V) <sup>(1,2)</sup>
FSFR2100	9-SIP	-40 to +130°C	0.38 $\Omega$	200 W	450 W

### Notes:

1. The junction temperature can limit the maximum output power.
2. Maximum practical continuous power in an open-frame design at 50°C ambient.

### Application Circuit Diagram

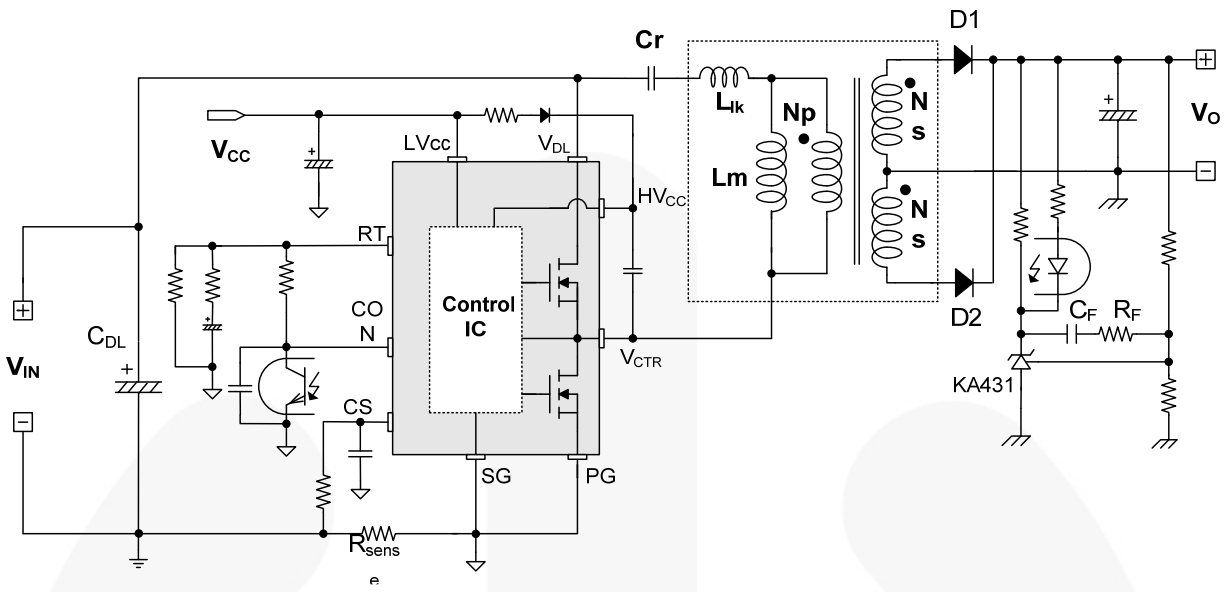

Figure 1. Typical Application Circuit (LLC Resonant Half-Bridge Converter)

### Block Diagram

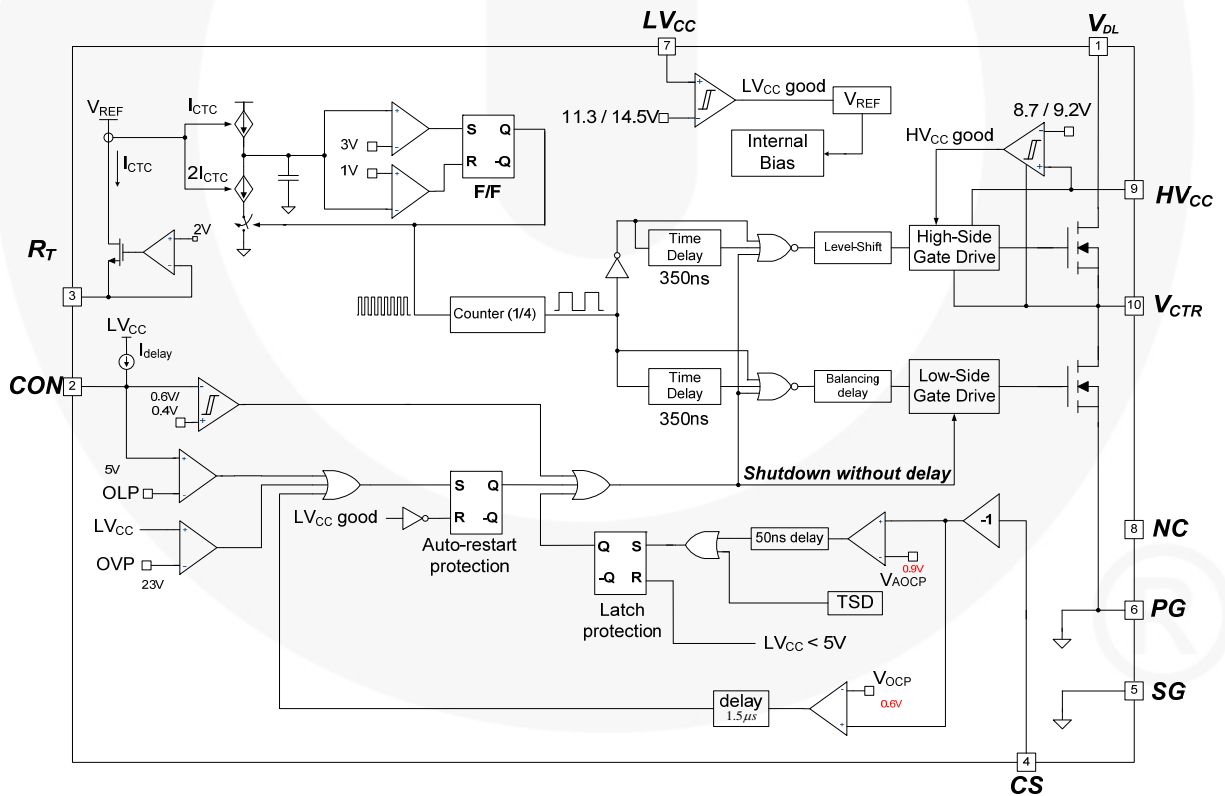

Figure 2. Internal Block Diagram

## Pin Configuration

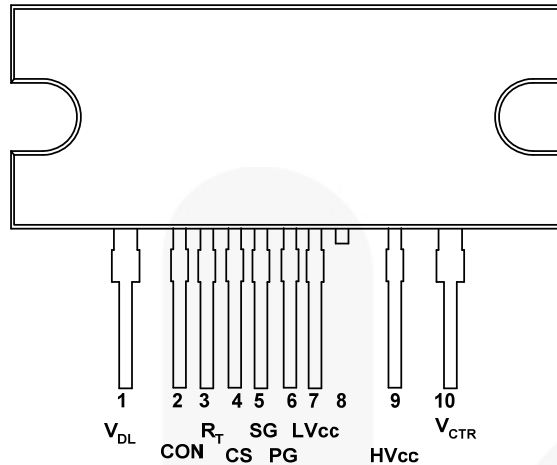

Figure 3. Package Diagram

## Pin Definitions

Pin #	Name	Description
1	V <sub>DL</sub>	This is the drain of the high-side MOSFET, typically connected to the input DC link voltage.
2	CON	This pin is for enable/disable and protection. When the voltage of this pin is above 0.6 V, the IC operation is enabled. When the voltage of this pin drops below 0.4 V, gate drive signals for both MOSFETs are disabled. When the voltage of this pin increases above 5 V, protection is triggered.
3	R <sub>T</sub>	This pin programs the switching frequency. Typically, an opto-coupler is connected to control the switching frequency for the output voltage regulation.
4	CS	This pin senses the current flowing through the low-side MOSFET. Typically, negative voltage is applied on this pin.
5	SG	This pin is the control ground.
6	PG	This pin is the power ground. This pin is connected to the source of the low-side MOSFET.
7	LV <sub>CC</sub>	This pin is the supply voltage of the control IC.
8	NC	No connection.
9	HV <sub>CC</sub>	This is the supply voltage of the high-side gate-drive circuit IC.
10	V <sub>CTR</sub>	This is the drain of the low-side MOSFET. Typically, a transformer is connected to this pin.

## Absolute Maximum Ratings

Stresses exceeding the absolute maximum ratings may damage the device. The device may not function or be operable above the recommended operating conditions and stressing the parts to these levels is not recommended. In addition, extended exposure to stresses above the recommended operating conditions may affect device reliability. The absolute maximum ratings are stress ratings only.  $T_A=25^{\circ}\text{C}$  unless otherwise specified.

Symbol	Parameter	Min.	Max.	Unit
$V_{DS}$	Maximum Drain-to-Source Voltage ( $V_{DL}-V_{CTR}$ and $V_{CTR}-PG$ )	600		V
$LV_{CC}$	Low-Side Supply Voltage	-0.3	25.0	V
$HV_{CC}$ to $V_{CTR}$	High-Side $V_{CC}$ Pin to Low-side Drain Voltage	-0.3	25.0	V
$HV_{CC}$	High-Side Floating Supply Voltage	-0.3	625.0	V
$V_{CON}$	Control Pin Input Voltage	-0.3	$LV_{CC}$	V
$V_{CS}$	Current Sense (CS) Pin Input Voltage	-5.0	1.0	V
$V_{RT}$	$R_T$ Pin Input Voltage	-0.3	5.0	V
$dV_{CTR}/dt$	Allowable Low-Side MOSFET Drain Voltage Slew Rate		50	V/ns
$P_D$	Total Power Dissipation <sup>(3)</sup>		12	W
$T_J$	Maximum Junction Temperature <sup>(4)</sup>		+150	°C
	Recommended Operating Junction Temperature <sup>(4)</sup>	-40	+130	
$T_{STG}$	Storage Temperature Range	-55	+150	°C
<b>MOSFET Section</b>				
$V_{DGR}$	Drain Gate Voltage ( $R_{GS}=1\text{ M}\Omega$ )	600		V
$V_{GS}$	Gate Source (GND) Voltage		$\pm 30$	V
$I_{DM}$	Drain Current Pulsed <sup>(5)</sup>		33	A
$I_D$	Continuous Drain Current	$T_C=25^{\circ}\text{C}$	11	A
		$T_C=100^{\circ}\text{C}$	7	
<b>Package Section</b>				
Torque	Recommended Screw Torque		5~7	kgf·cm

### Notes:

- Per MOSFET when both MOSFETs are conducting.
- The maximum value of the recommended operating junction temperature is limited by thermal shutdown.
- Pulse width is limited by maximum junction temperature.

## Thermal Impedance

$T_A=25^{\circ}\text{C}$  unless otherwise specified.

Symbol	Parameter	Value	Unit
$\theta_{JC}$	Junction-to-Case Center Thermal Impedance (Both MOSFETs Conducting)	10.44	°C/W
$\theta_{JA}$	Junction-to-Ambient Thermal Impedance	80	°C/W

## Electrical Characteristics

T<sub>A</sub>=25°C unless otherwise specified.

Symbol	Parameter	Test Conditions	Min.	Typ.	Max.	Unit
<b>MOSFET Section</b>						
BV <sub>DSS</sub>	Drain-to-Source Breakdown Voltage	I <sub>D</sub> =200 μA, T <sub>A</sub> =25°C	600			V
		I <sub>D</sub> =200 μA, T <sub>A</sub> =125°C		650		
R <sub>DS(ON)</sub>	On-State Resistance	V <sub>GS</sub> =10 V, I <sub>D</sub> =5.5 A		0.32	0.38	Ω
t <sub>rr</sub>	Body Diode Reverse Recovery Time <sup>(6)</sup>	V <sub>GS</sub> =0 V, I <sub>Diode</sub> =11.0 A		120		ns
C <sub>ISS</sub>	Input Capacitance <sup>(6)</sup>	V <sub>DS</sub> =25V, V <sub>GS</sub> =0 V, f=1.0 MHz		1148		pF
C <sub>OSS</sub>	Output Capacitance <sup>(6)</sup>			671		pF
<b>Supply Section</b>						
I <sub>LK</sub>	Offset Supply Leakage Current	H-V <sub>CC</sub> =V <sub>CTR</sub> =600 V/500 V			50	μA
I <sub>QHVCC</sub>	Quiescent HV <sub>CC</sub> Supply Current	(HV <sub>CC</sub> UV+) - 0.1 V		50	120	μA
I <sub>QLVCC</sub>	Quiescent LV <sub>CC</sub> Supply Current	(LV <sub>CC</sub> UV+) - 0.1 V		100	200	μA
I <sub>OHVCC</sub>	Operating HV <sub>CC</sub> Supply Current (RMS Value)	f <sub>OSC</sub> =100 KHz, V <sub>CON</sub> > 0.6 V		6	9	mA
		No Switching, V <sub>CON</sub> < 0.4 V		100	200	μA
I <sub>OLVCC</sub>	Operating LV <sub>CC</sub> Supply Current (RMS Value)	f <sub>OSC</sub> =100KHz, V <sub>CON</sub> > 0.6 V		7	11	mA
		No Switching, V <sub>CON</sub> < 0.4 V		2	4	mA
<b>UVLO Section</b>						
LV <sub>CC</sub> UV+	LV <sub>CC</sub> Supply Under-Voltage Positive-Going Threshold (LV <sub>CC</sub> Start)		13.0	14.5	16.0	V
LV <sub>CC</sub> UV-	LV <sub>CC</sub> Supply Under-Voltage Negative-Going Threshold (LV <sub>CC</sub> Stop)		10.2	11.3	12.4	V
LV <sub>CC</sub> UVH	LV <sub>CC</sub> Supply Under-Voltage Hysteresis			3.2		V
HV <sub>CC</sub> UV+	HV <sub>CC</sub> Supply Under-Voltage Positive-Going Threshold (HV <sub>CC</sub> Start)		8.2	9.2	10.2	V
HV <sub>CC</sub> UV-	HV <sub>CC</sub> Supply Under-Voltage Negative-Going Threshold (HV <sub>CC</sub> Stop)		7.8	8.7	9.6	V
HV <sub>CC</sub> UVH	HV <sub>CC</sub> Supply Under-Voltage Hysteresis			0.5		V
<b>Oscillator &amp; Feedback Section</b>						
V <sub>CONDIS</sub>	Control Pin Disable Threshold Voltage		0.36	0.40	0.44	V
V <sub>CONEN</sub>	Control Pin Enable Threshold Voltage		0.54	0.60	0.66	V
V <sub>RT</sub>	V-I Converter Threshold Voltage		1.5	2.0	2.5	V
f <sub>OSC</sub>	Output Oscillation Frequency	R <sub>T</sub> =5.2 KΩ	94	100	106	KHz
DC	Output Duty Cycle		48	50	52	%
f <sub>SS</sub>	Internal Soft-Start Initial Frequency		f <sub>SS</sub> =f <sub>OSC</sub> +40 kHz, R <sub>T</sub> =5.2 KΩ		140	
t <sub>SS</sub>	Internal Soft-Start Time		2	3	4	ms

Continued on the following page...

**Electrical Characteristics** (Continued)

 $T_A=25^{\circ}\text{C}$  unless otherwise specified.

Symbol	Parameter	Test Conditions	Min.	Typ.	Max.	Unit
<b>Protection Section</b>						
$I_{OLP}$	OLP Delay Current	$V_{CON}=4\text{ V}$	3.6	4.8	6.0	$\mu\text{A}$
$V_{OLP}$	OLP Protection Voltage	$V_{CON} > 3.5\text{ V}$	4.5	5.0	5.5	V
$V_{OVP}$	LV <sub>CC</sub> Over-Voltage Protection	$L-V_{CC} > 21\text{ V}$	21	23	25	V
$V_{AOCP}$	AOCP Threshold Voltage	$\Delta V/\Delta t=-0.1\text{ V}/\mu\text{s}$	-1.0	-0.9	-0.8	V
$t_{BAO}$	AOCP Blanking Time <sup>(6)</sup>	$V_{CS} < V_{AOCP}$ ; $\Delta V/\Delta t=-0.1\text{ V}/\mu\text{s}$		50		ns
$V_{OCP}$	OCP Threshold Voltage	$V/\Delta t=-1\text{ V}/\mu\text{s}$	-0.64	-0.58	-0.52	V
$t_{BO}$	OCP Blanking Time <sup>(6)</sup>	$V_{CS} < V_{OCP}$ ; $\Delta V/\Delta t=-1\text{ V}/\mu\text{s}$	1.0	1.5	2.0	$\mu\text{s}$
$t_{DA}$	Delay Time (Low Side) Detecting from V <sub>AOCP</sub> to Switch Off <sup>(6)</sup>	$\Delta V/\Delta t=-1\text{ V}/\mu\text{s}$		250	400	ns
$T_{SD}$	Thermal Shutdown Temperature <sup>(6)</sup>		110	130	150	$^{\circ}\text{C}$
$I_{SU}$	Protection Latch Sustain LV <sub>CC</sub> Supply Current	$LV_{CC}=7.5\text{ V}$		100	150	$\mu\text{A}$
$V_{PRSET}$	Protection Latch Reset LV <sub>CC</sub> Supply Voltage		5			V
<b>Dead-Time Control Section</b>						
$D_T$	Dead Time <sup>(7)</sup>			350		ns

**Notes:**

6. This parameter, although guaranteed, is not tested in production.
7. These parameters, although guaranteed, are tested only in EDS (wafer test) process.

## Typical Performance Characteristics

These characteristic graphs are normalized at  $T_A=25^\circ\text{C}$ .

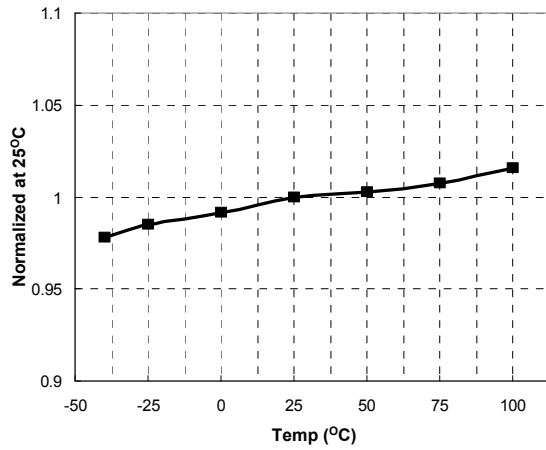

**Figure 4. Low-Side MOSFET Duty Cycle vs. Temperature**

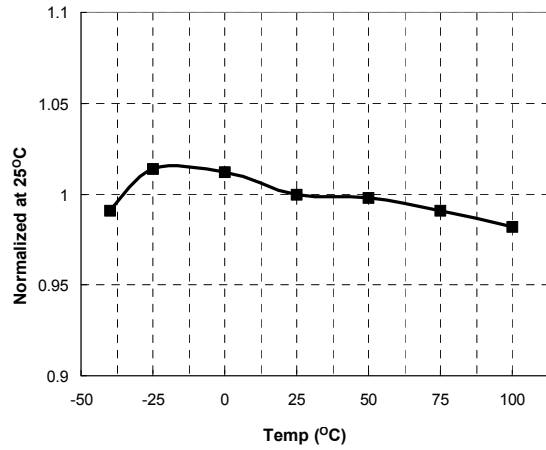

**Figure 5. Switching Frequency vs. Temperature**

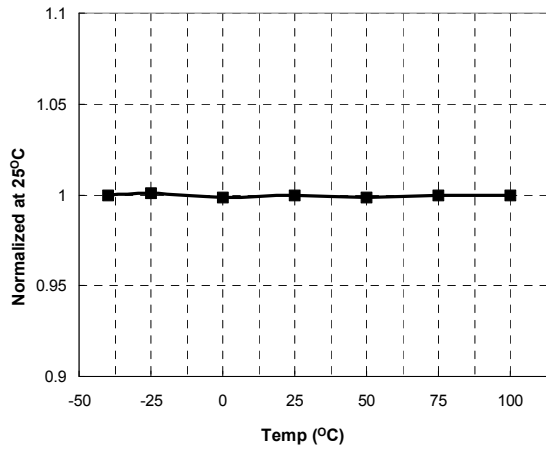

**Figure 6. High-Side  $V_{CC}$  ( $HV_{CC}$ ) Start vs. Temperature**

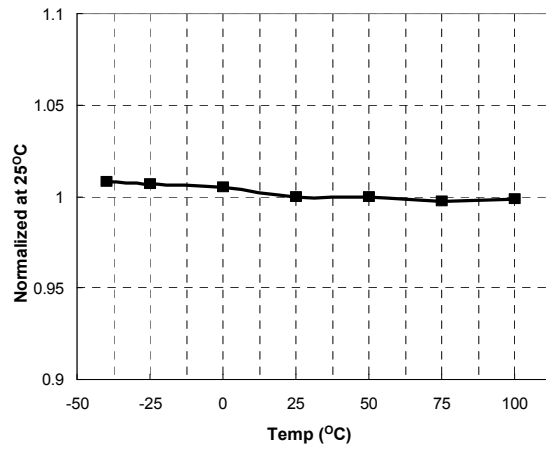

**Figure 7. High-Side  $V_{CC}$  ( $HV_{CC}$ ) Stop vs. Temperature**

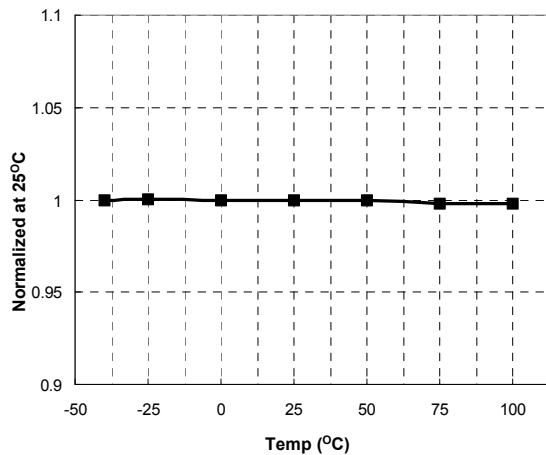

**Figure 8. Low-Side  $V_{CC}$  ( $LV_{CC}$ ) Start vs. Temperature**

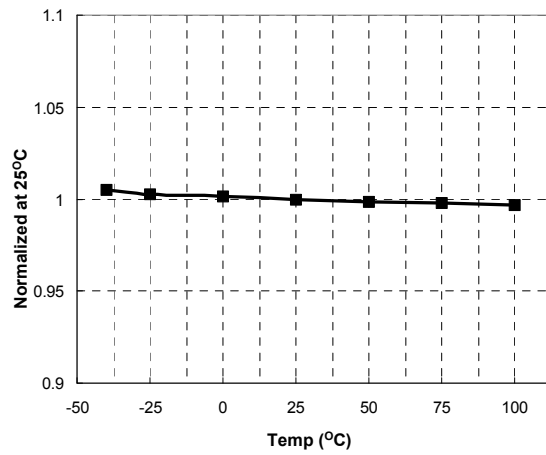
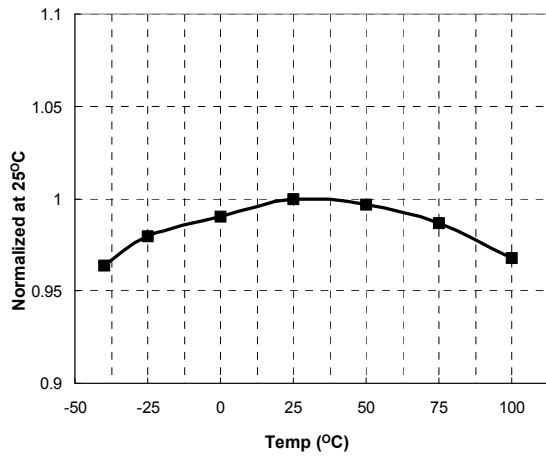

**Figure 9. Low-Side  $V_{CC}$  ( $LV_{CC}$ ) Stop vs. Temperature**



## Typical Performance Characteristics (Continued)

These characteristic graphs are normalized at  $T_A=25^\circ\text{C}$ .



**Figure 10. OLP Delay Current vs. Temperature**

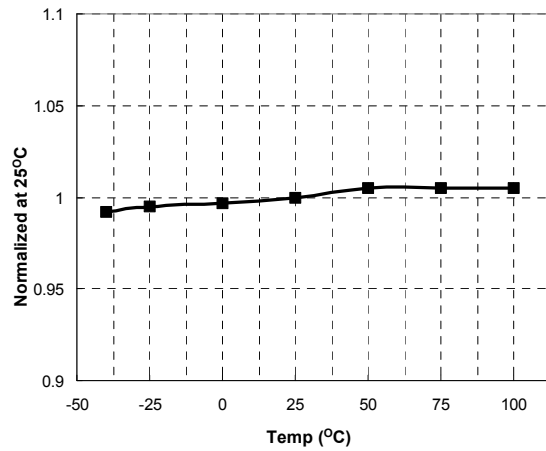

**Figure 11. OLP Protection Voltage vs. Temperature**

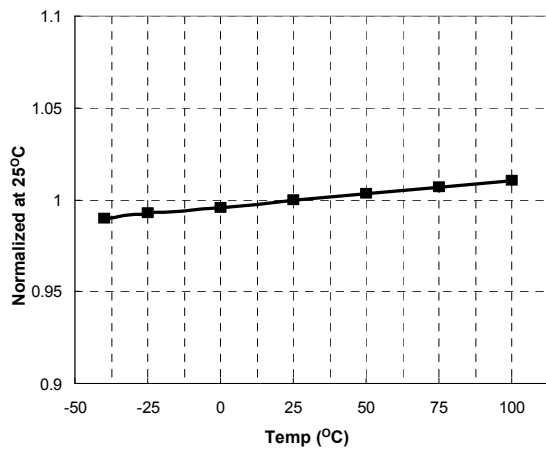

**Figure 12. LV<sub>CC</sub> OVP Voltage vs. Temperature**

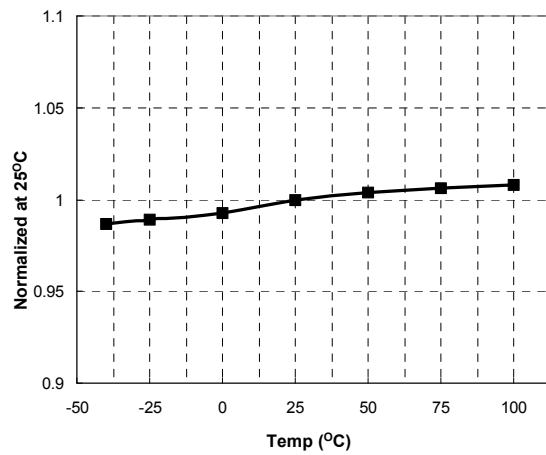

**Figure 13. R<sub>T</sub> Voltage vs. Temperature**

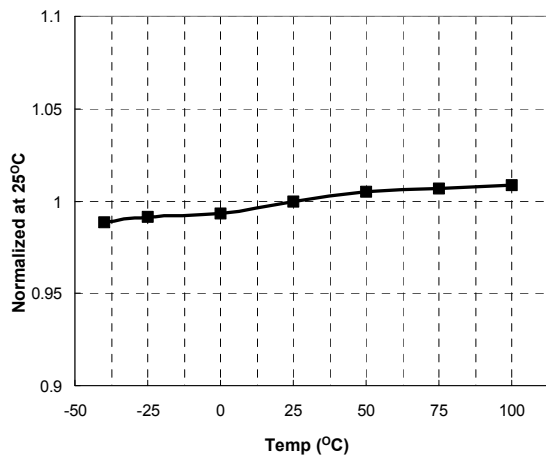

**Figure 14. CON Pin Enable Voltage vs. Temperature**

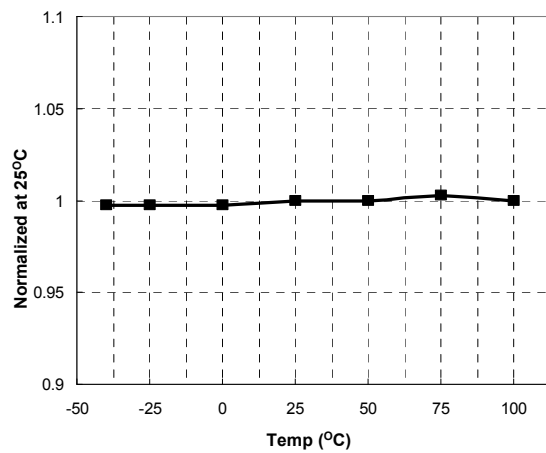

**Figure 15. OCP Voltage vs. Temperature**

## Functional Description

### 1. Basic Operation

FSFR2100 is designed to drive high-side and low-side MOSFETs complementarily with 50% duty cycle. A fixed dead time of 350 ns is introduced between consecutive transitions, as shown in Figure 16.

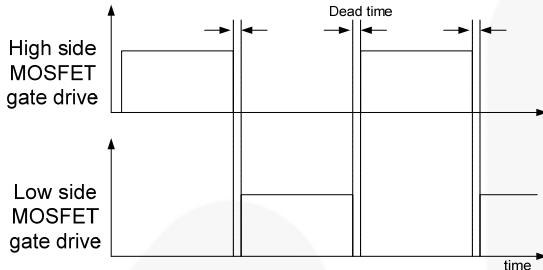

Figure 16. MOSFETs Gate Drive Signal

### 2. Internal Oscillator

FSFR2100 employs a current-controlled oscillator, as shown in Figure 17. Internally, the voltage of  $R_T$  pin is regulated at 2 V and the charging/discharging current for the oscillator capacitor,  $C_T$ , is obtained by copying the current flowing out of  $R_T$  pin ( $I_{CTC}$ ) using a current mirror. Therefore, the switching frequency increases as  $I_{CTC}$  increases.

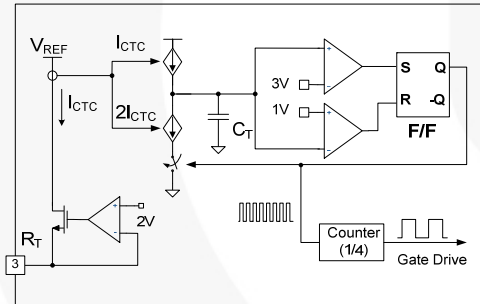

Figure 17. Current Controlled Oscillator

### 3. Frequency Setting

Figure 18 shows a typical voltage gain curve of a resonant converter, where the gain is inversely proportional to the switching frequency in the ZVS region. The output voltage can be regulated by modulating the switching frequency. Figure 19 shows the typical circuit configuration for  $R_T$  pin, where the opto-coupler transistor is connected to the  $R_T$  pin to modulate the switching frequency.

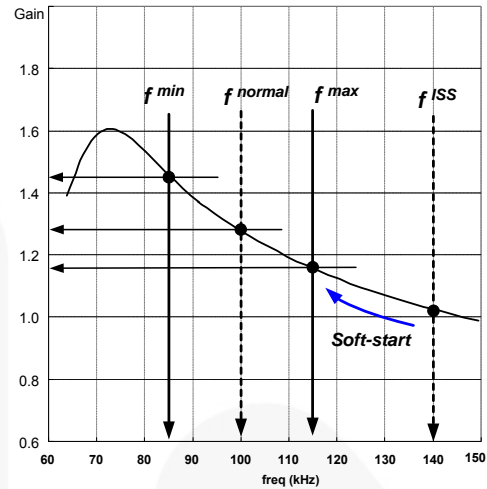

Figure 18. Resonant Converter Typical Gain Curve

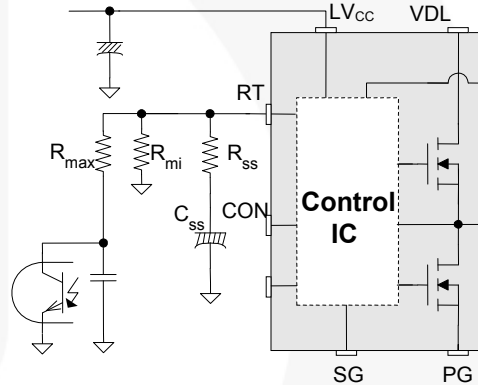

Figure 19. Frequency Control Circuit

The minimum switching frequency is determined as:

$$f^{\min} = \frac{5.2k\Omega}{R_{\min}} \times 100(kHz) \quad (1)$$

Assuming the saturation voltage of opto-coupler transistor is 0.2 V, the maximum switching frequency is determined as:

$$f^{\max} = \left( \frac{5.2k\Omega}{R_{\min}} + \frac{4.68k\Omega}{R_{\max}} \right) \times 100(kHz) \quad (2)$$

To prevent excessive inrush current and overshoot of output voltage during startup, increase the voltage gain of the resonant converter progressively. Since the voltage gain of the resonant converter is inversely proportional to the switching frequency, the soft-start is implemented by sweeping down the switching frequency from an initial high frequency ( $f^{SS}$ ) until the output voltage is established. The soft-start circuit is made by connecting R-C series network on the  $R_T$  pin, as shown in Figure 19. FSFR2100 also has an internal soft-start for

3 ms to reduce the current overshoot during the initial cycles, which adds 40 kHz to the initial frequency of the external soft-start circuit, as shown in Figure 20. The initial frequency of the soft-start is given as:

$$f^{ISS} = \left( \frac{5.2k\Omega}{R_{min}} + \frac{5.2k\Omega}{R_{SS}} \right) \times 100 + 40 \text{ (kHz)} \quad (3)$$

It is typical to set the initial frequency of soft-start two ~ three times the resonant frequency ( $f_0$ ) of the resonant network.

The soft-start time is three to four times of the RC time constant. The RC time constant is as follows:

$$T_{SS} = R_{SS} \cdot C_{SS} \quad (4)$$

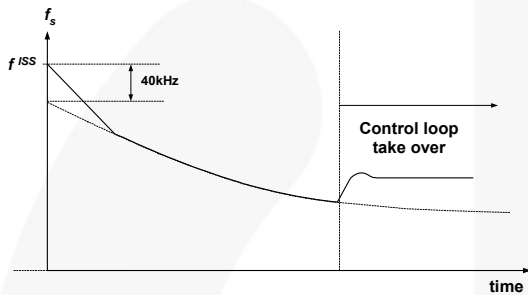

Figure 20. Frequency Sweeping of Soft-start

#### 4. Control Pin

The FSFR2100 has a control pin for protection, cycle skipping, and remote on/off. Figure 21 shows the internal block diagram for control pin.

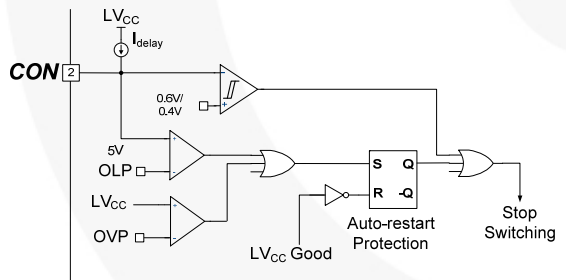

Figure 21. Internal Block of Control Pin

**Protection:** When the control pin voltage exceeds 5V, protection is triggered. Detailed applications are described in the protection section.

**Pulse Skipping:** FSFR2100 stops switching when the control pin voltage drops below 0.4 V and resumes switching when the control pin voltage rises above 0.6 V. To use pulse-skipping, the control pin should be connected to the opto-coupler collector pin. The frequency that causes pulse skipping is given as:

$$f^{SKIP} = \left( \frac{5.2k\Omega}{R_{min}} + \frac{4.16k\Omega}{R_{max}} \right) \times 100 \text{ (kHz)} \quad (5)$$

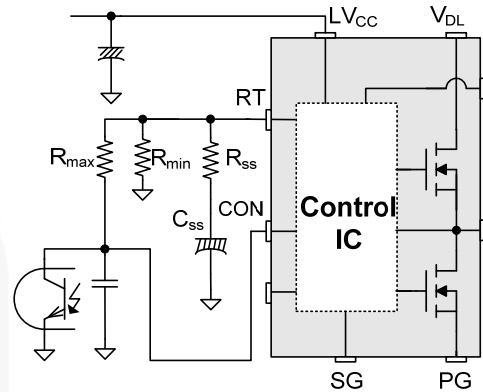

Figure 22. Control Pin Configuration for Pulse Skipping

**Remote On / Off:** When an auxiliary power supply is used for standby, the main power stage using FSFR2100 can be shut down by pulling down the control pin voltage, as shown in Figure 23. R1 and C1 are used to ensure soft-start when switching resumes.

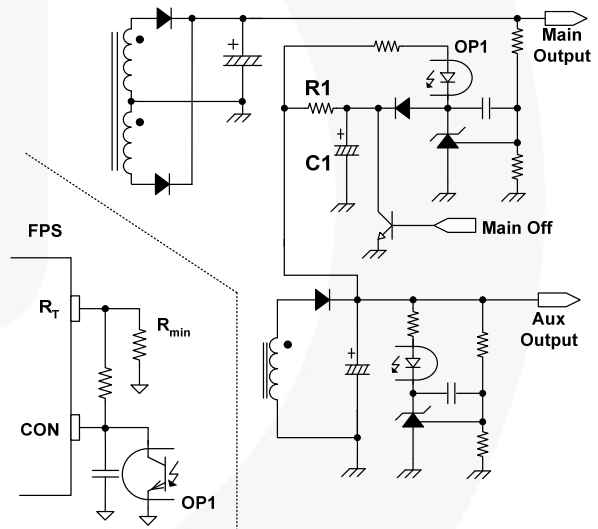

Figure 23. Remote On / Off Circuit

## 5. Current Sensing

**Current Sensing Using Resistor:** FSFR2100 senses drain current as a negative voltage, as shown in Figure 24 and Figure 25. Half-wave sensing allows low power dissipation in the sensing resistor, while full-wave sensing has less switching noise in the sensing signal.

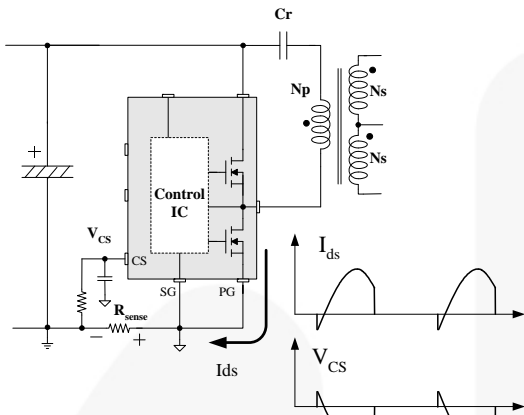

Figure 24. Half-Wave Sensing

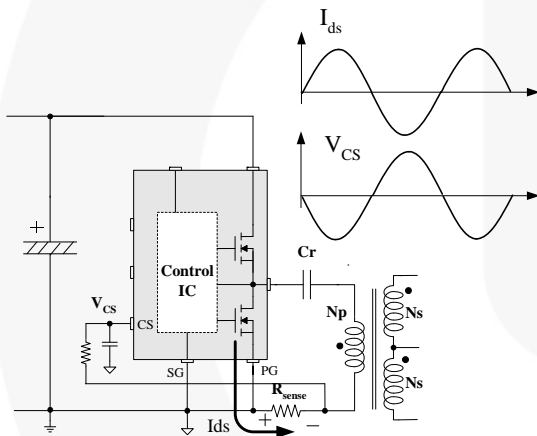

Figure 25. Full-Wave Sensing

### Current Sensing Using Resonant Capacitor Voltage:

For high-power applications, current sensing using a resistor may not be available due to the severe power dissipation in the resistor. In that case, indirect current sensing using the resonant capacitor voltage can be a good alternative because the amplitude of the resonant capacitor voltage ( $V_{Cr}^{p-p}$ ) is proportional to the resonant current in the primary side ( $I_p^{p-p}$ ) as:

$$V_{Cr}^{p-p} = \frac{I_p^{p-p}}{2\pi f_s C_r} \quad (6)$$

To minimize power dissipation, a capacitive voltage divider is generally used for capacitor voltage sensing, as shown in Figure 26.

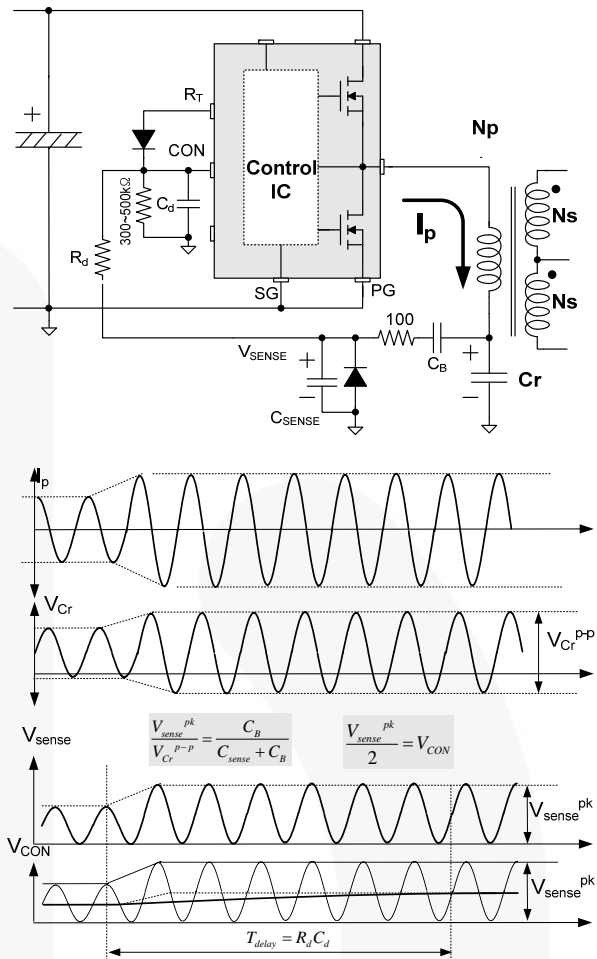

Figure 26. Current Sensing Using Resonant Capacitor Voltage

## 6. Protection Circuits

The FSFR2100 has several self-protective functions, such as Overload Protection (OLP), Over-Current Protection (OCP), Abnormal Over-Current Protection (AOCP), Over-Voltage Protection (OVP), and Thermal Shutdown (TSD). OLP, OCP, and OVP are auto-restart mode protections; while AOCP and TSD are latch-mode protections, as shown in Figure 27.

**6.1 Auto-restart Mode Protection:** Once a fault condition is detected, switching is terminated and the MOSFETs remain off. When  $LV_{CC}$  falls to the  $LV_{CC}$  stop voltage of 11.3 V, the protection is reset. The FPS resumes normal operation when  $LV_{CC}$  reaches the start voltage of 14.5 V.

**6.2 Latch-Mode Protection:** Once this protection is triggered, switching is terminated and the MOSFETs remain off. The latch is reset only when LV<sub>CC</sub> is discharged below 5 V.

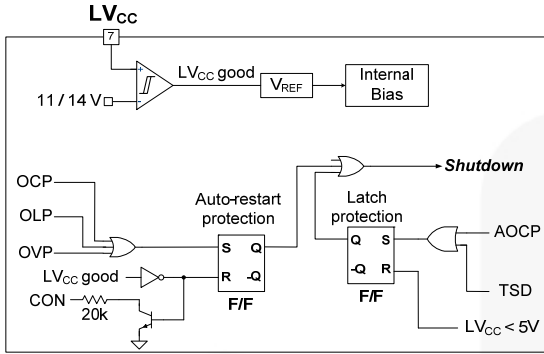

Figure 27. Protection Blocks

**6.3 Over-Current Protection (OCP):** When the sensing pin voltage drops below -0.58 V, OCP is triggered and the MOSFETs remain off. This protection has a shutdown time delay of 1.5 μs to prevent premature shutdown during startup.

**6.4 Abnormal Over-Current Protection (AOCPP):** If the secondary rectifier diodes are shorted, large current with extremely high di/dt can flow through the MOSFET before OCP or OLP is triggered. AOCPP is triggered without shutdown delay when the sensing pin voltage drops below -0.9V. This protection is latch mode and reset when LV<sub>CC</sub> is pulled down below 5 V.

**6.5 Overload Protection (OLP):** Overload is defined as the load current exceeding its normal level due to an unexpected abnormal event. In this situation, the protection circuit should trigger to protect the power supply. However, even when the power supply is in the normal condition, the overload situation can occur during the load transition. To avoid premature triggering of protection, the overload protection circuit should be designed to trigger only after a specified time to determine whether it is a transient situation or a true overload situation. Figure 26 shows a typical overload protection circuit. By sensing the resonant capacitor voltage on the control pin, the overload protection can be implemented. Using RC time constant, shutdown delay can be also introduced. The voltage obtained on the control pin is given as:

$$V_{CON} = \frac{C_B}{2(C_B + C_{sense})} V_{Cr}^{p-p} \quad (7)$$

where V<sub>Cr</sub><sup>p-p</sup> is the amplitude of the resonant capacitor voltage.

**6.6 Over-Voltage Protection (OVP):** When the LV<sub>CC</sub> reaches 23 V, OVP is triggered. This protection is used when auxiliary winding of the transformer to supply V<sub>CC</sub> to FPS™ is utilized.

**6.7 Thermal Shutdown (TSD):** The MOSFETs and the control IC in one package makes it easy for the control IC to detect the abnormal over-temperature of the MOSFETs. If the temperature exceeds approximately 130°C, the thermal shutdown triggers.

## 7. PCB Layout Guidelines

Duty unbalance problems may occur due to the radiated noise from main transformer, the inequality of the secondary side leakage inductances of main transformer, and so on. Among them, it is one of the dominant reasons that the control components in the vicinity of R<sub>T</sub> pin are enclosed by the primary current flow pattern on PCB layout. The direction of the magnetic field on the components caused by the primary current flow is changed when the high and low side MOSFET turns on by turns. The magnetic fields with opposite direction from each other induce a current through, into, or out of the R<sub>T</sub> pin, which makes the turn-on duration of each MOSFET different. It is highly recommended to separate the control components in the vicinity of R<sub>T</sub> pin from the primary current flow pattern on PCB layout. Figure 28 shows an example for the duty balanced case.

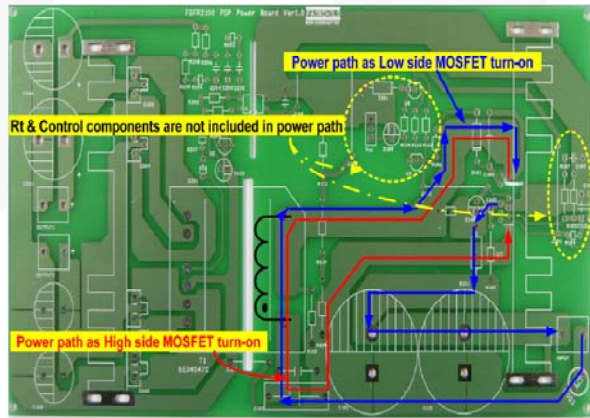

Figure 28. Example for Duty Balancing

### Typical Application Circuit (Half-Bridge LLC Resonant Converter)

Application	FPS™ Device	Input Voltage Range	Rated Output Power	Output Voltage (Rated Current)
LCD TV	FSFR2100	390 V <sub>DC</sub> (340~400 V <sub>DC</sub> )	200 W	24 V-8.3 A

#### Features

- High efficiency ( >94% at 400 V<sub>DC</sub> input)
- Reduced EMI noise through zero-voltage-switching (ZVS)
- Enhanced system reliability with various protection functions

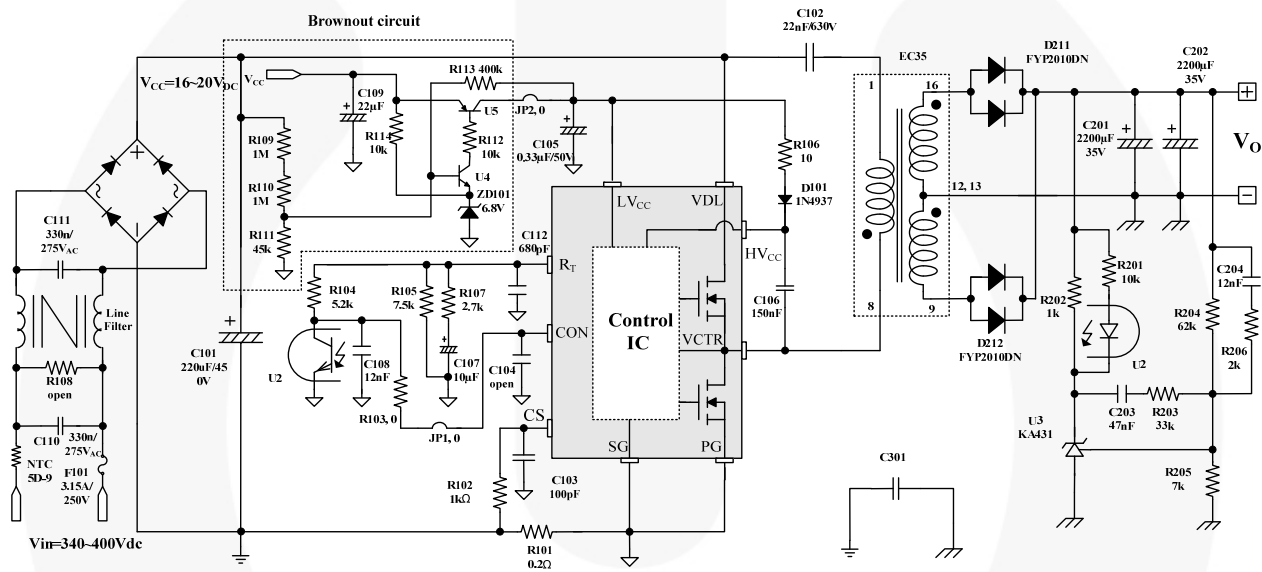

Figure 29. Typical Application Circuit

## Typical Application Circuit (Continued)

Usually, LLC resonant converters require large leakage inductance value. To obtain a large leakage inductance, sectional winding method is used.

- Core: EC35 ( $A_e=106 \text{ mm}^2$ )
- Bobbin: EC35 (Horizontal)
- Transformer Model Number: SNX-2468-1

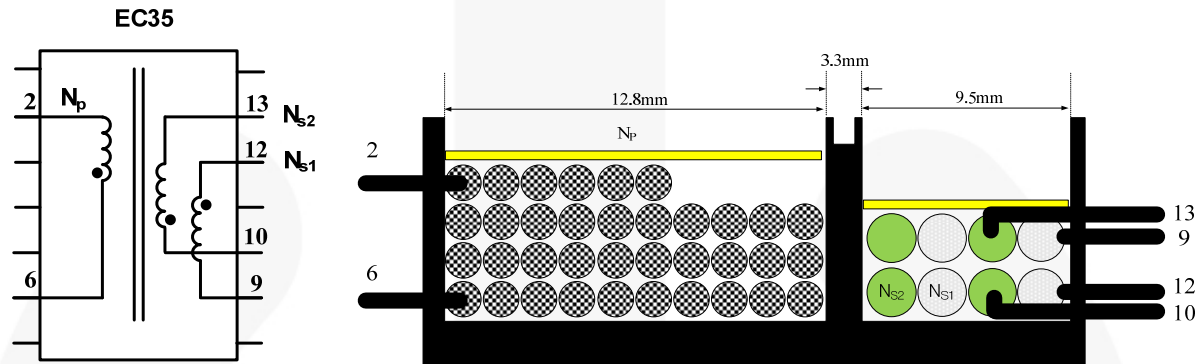
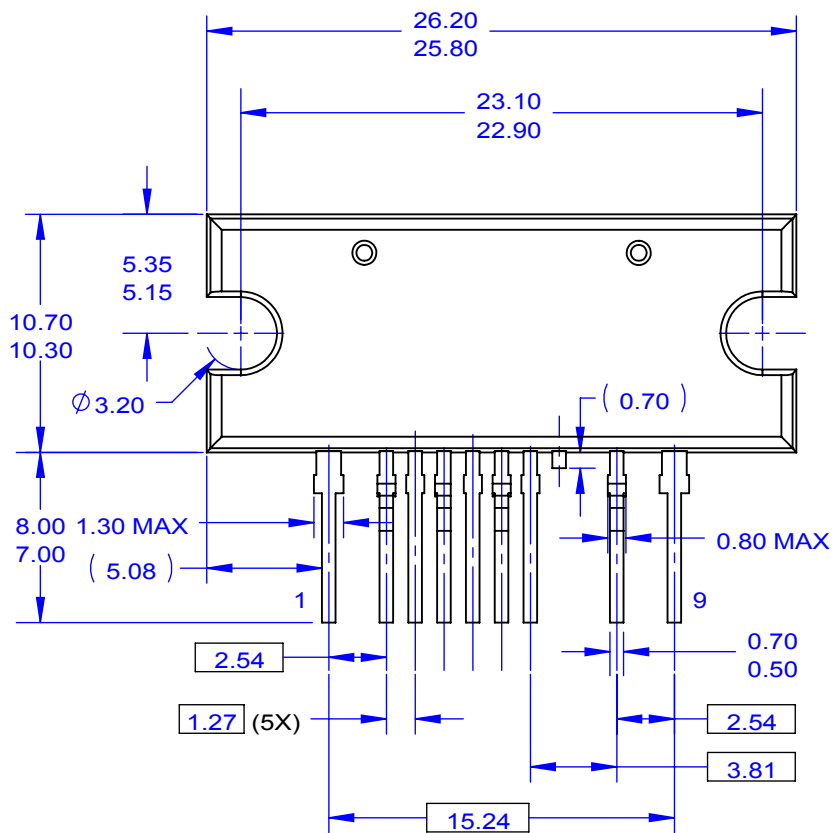

Figure 30. Transformer Construction

	Pin (S → F)	Wire	Turns	Note
$N_p$	6 → 2	0.08 $\phi$ ×88 (Litz Wire)	36	
$N_{s1}$	12 → 9	0.08 $\phi$ ×234 (Litz Wire)	4	Bifilar Winding
$N_{s2}$	10 → 13	0.08 $\phi$ ×234 (Litz Wire)	4	Bifilar Winding

	Pins	Specifications	Remark
Primary-Side Inductance ( $L_p$ )	2 6	550 $\mu$ H $\pm$ 10%	100 kHz, 1 V
Primary-Side Effective Leakage ( $L_r$ )	2 6	110 $\mu$ H $\pm$ 10%	Short one of the Secondary Windings

For more detailed information regarding the transformer, visit <http://www.santronics-usa.com/documents.html> or contact [sales@santronics-usa.com](mailto:sales@santronics-usa.com) or +1-408-734-1878 (Sunnyvale, California USA).



FRONT VIEW

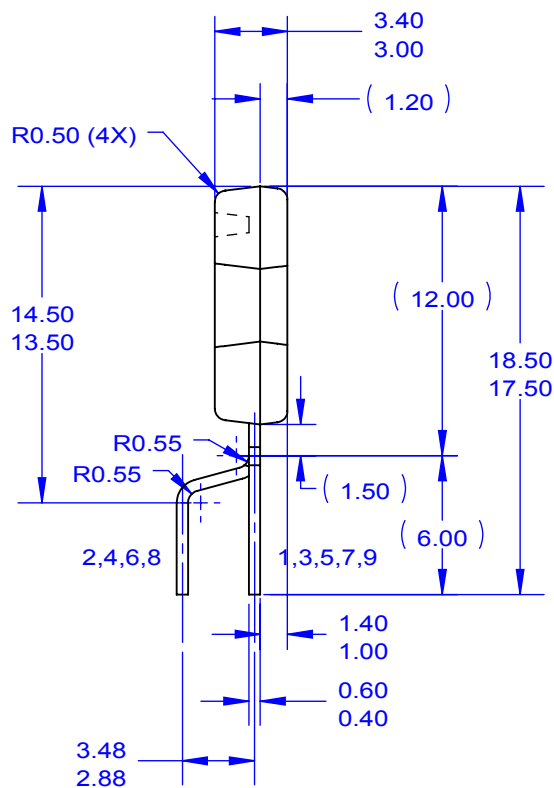

RIGHT SIDE VIEW

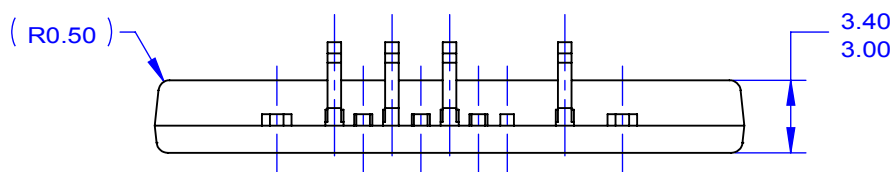

BOTTOM VIEW



NOTES: UNLESS OTHERWISE SPECIFIED

- A. THIS PACKAGE DOES NOT COMPLY TO ANY CURRENT PACKAGING STANDARD.
- B. ALL DIMENSIONS ARE IN MILLIMETERS.
- C. DIMENSIONS ARE EXCLUSIVE OF BURRS, MOLD FLASH AND TIE BAR PROTRUSIONS.
- D. DRAWING FILE NAME: MOD09ACREV3



ON Semiconductor and  are trademarks of Semiconductor Components Industries, LLC dba ON Semiconductor or its subsidiaries in the United States and/or other countries. ON Semiconductor owns the rights to a number of patents, trademarks, copyrights, trade secrets, and other intellectual property. A listing of ON Semiconductor's product/patent coverage may be accessed at [www.onsemi.com/site/pdf/Patent-Marking.pdf](http://www.onsemi.com/site/pdf/Patent-Marking.pdf). ON Semiconductor reserves the right to make changes without further notice to any products herein. ON Semiconductor makes no warranty, representation or guarantee regarding the suitability of its products for any particular purpose, nor does ON Semiconductor assume any liability arising out of the application or use of any product or circuit, and specifically disclaims any and all liability, including without limitation special, consequential or incidental damages. Buyer is responsible for its products and applications using ON Semiconductor products, including compliance with all laws, regulations and safety requirements or standards, regardless of any support or applications information provided by ON Semiconductor. "Typical" parameters which may be provided in ON Semiconductor data sheets and/or specifications can and do vary in different applications and actual performance may vary over time. All operating parameters, including "Typicals" must be validated for each customer application by customer's technical experts. ON Semiconductor does not convey any license under its patent rights nor the rights of others. ON Semiconductor products are not designed, intended, or authorized for use as a critical component in life support systems or any FDA Class 3 medical devices or medical devices with a same or similar classification in a foreign jurisdiction or any devices intended for implantation in the human body. Should Buyer purchase or use ON Semiconductor products for any such unintended or unauthorized application, Buyer shall indemnify and hold ON Semiconductor and its officers, employees, subsidiaries, affiliates, and distributors harmless against all claims, costs, damages, and expenses, and reasonable attorney fees arising out of, directly or indirectly, any claim of personal injury or death associated with such unintended or unauthorized use, even if such claim alleges that ON Semiconductor was negligent regarding the design or manufacture of the part. ON Semiconductor is an Equal Opportunity/Affirmative Action Employer. This literature is subject to all applicable copyright laws and is not for resale in any manner.

## PUBLICATION ORDERING INFORMATION

### LITERATURE FULFILLMENT:

Literature Distribution Center for ON Semiconductor  
19521 E. 32nd Pkwy, Aurora, Colorado 80011 USA  
**Phone:** 303-675-2175 or 800-344-3860 Toll Free USA/Canada  
**Fax:** 303-675-2176 or 800-344-3867 Toll Free USA/Canada  
**Email:** [orderlit@onsemi.com](mailto:orderlit@onsemi.com)

**N. American Technical Support:** 800-282-9855 Toll Free  
USA/Canada  
**Europe, Middle East and Africa Technical Support:**  
Phone: 421 33 790 2910  
**Japan Customer Focus Center**  
Phone: 81-3-5817-1050

**ON Semiconductor Website:** [www.onsemi.com](http://www.onsemi.com)  
**Order Literature:** <http://www.onsemi.com/orderlit>  
For additional information, please contact your local  
Sales Representative

# Mouser Electronics

Authorized Distributor

Click to View Pricing, Inventory, Delivery & Lifecycle Information:

[ON Semiconductor:](#)

[FEBFSFR2100\\_D015v1](#) [FSFR2100](#)



**Стандарт  
Электрон  
Связь**

Мы молодая и активно развивающаяся компания в области поставок электронных компонентов. Мы поставляем электронные компоненты отечественного и импортного производства напрямую от производителей и с крупнейших складов мира.

Благодаря сотрудничеству с мировыми поставщиками мы осуществляем комплексные и плановые поставки широчайшего спектра электронных компонентов.

Собственная эффективная логистика и склад в обеспечивает надежную поставку продукции в точно указанные сроки по всей России.

Мы осуществляем техническую поддержку нашим клиентам и предпродажную проверку качества продукции. На все поставляемые продукты мы предоставляем гарантию .

Осуществляем поставки продукции под контролем ВП МО РФ на предприятия военно-промышленного комплекса России , а также работаем в рамках 275 ФЗ с открытием отдельных счетов в уполномоченном банке. Система менеджмента качества компании соответствует требованиям ГОСТ ISO 9001.

Минимальные сроки поставки, гибкие цены, неограниченный ассортимент и индивидуальный подход к клиентам являются основой для выстраивания долгосрочного и эффективного сотрудничества с предприятиями радиоэлектронной промышленности, предприятиями ВПК и научно-исследовательскими институтами России.

С нами вы становитесь еще успешнее!

**Наши контакты:**

**Телефон:** +7 812 627 14 35

**Электронная почта:** [sales@st-electron.ru](mailto:sales@st-electron.ru)

**Адрес:** 198099, Санкт-Петербург,  
Промышленная ул, дом № 19, литера Н,  
помещение 100-Н Офис 331