

### Product Overview

The QPA9120 is a wideband, high gain, and high linearity driver amplifier in a low-cost, RoHS compliant 3x3 mm QFN package. With Qorvo's E-pHEMT process, this amplifier delivers exceptional performance with 36 dBm output 3<sup>rd</sup> order intercept (OIP3) power and 22 dBm output 1 dB compression (OP1dB) power while consuming less than 100 mA DC current with single 5V supply.

The QPA9120 incorporates on-chip features with fast DC power shutdown, externally configurable device DC operation current, and is internally matched.

The QPA9120 is targeted for use as a pre-driver amplifier for wireless infrastructure where high linearity, medium RF power with efficient DC power operation are required. The device is an excellent choice for 5G dense-array m-MIMO radio applications.

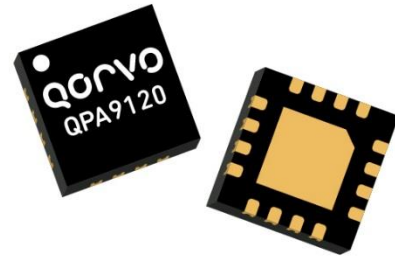

16 Pad 3 x 3 mm QFN Package

### Key Features

- 1.8–5.0 GHz Operational
- 50Ω Matched RF Input and Output
- 1 dB Gain Flatness over 1 GHz Bandwidth
- +22 dBm P1dB
- +35 dBm Output IP3
- 29 dB Gain
- +5 V Single Supply, I<sub>DD</sub> 96 mA
- DC Power Shutdown Feature
- Small 3 x 3 mm QFN Package

### Functional Block Diagram

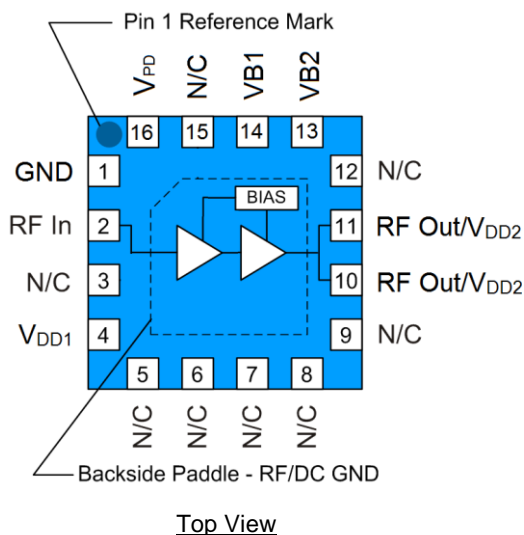

### Applications

- 5G m-MIMO
- Mobile Infrastructure
- Repeater / DAS
- General Purpose Wireless
- TDD / FDD System

### Ordering Information

Part No.	Description
QPA9120TR7	2,500 pieces on a 7" reel (standard)
QPA9120EVB-01	Evaluation Board

## Absolute Maximum Ratings

Parameter	Rating
Storage Temperature	-65 to +150 °C
RF Input Power, CW, 50 Ω, T=25 °C	22 dBm
Device Voltage (V <sub>DD1</sub> , V <sub>DD2</sub> )	+6 V

Exceeding any one or a combination of the Absolute Maximum Rating conditions may cause permanent damage to the device. Extended application of Absolute Maximum Rating conditions to the device may reduce device reliability.

## Recommended Operating Conditions

Parameter	Min	Typ	Max	Units
Device Voltage (V <sub>DD1</sub> , V <sub>DD2</sub> )	+3.3	+5.0	+5.25	V
T <sub>CASE</sub>	-40		+105	°C
T <sub>j</sub> for >10 <sup>6</sup> hours MTTF			+190	°C

Electrical specifications are measured at specified test conditions. Specifications are not guaranteed over all recommended operating conditions.

## Electrical Specifications

Parameter	Conditions <sup>(1)</sup>	Min	Typ	Max	Units
Operational Frequency Range		1800		5000	MHz
Gain	At 3.5 GHz	27	29	33	dB
	At 4.8 GHz	26	28	32.5	dB
Input Return Loss			10		dB
Output Return Loss			12		dB
Output P <sub>1dB</sub>	At 3.5 GHz	20	22		dBm
	At 4.8 GHz	19	21		dBm
Output IP <sub>3</sub>	P <sub>out</sub> = +2 dBm/tone, Δf = 1 MHz, 3.5 GHz	32	35		dBm
	P <sub>out</sub> = +2 dBm/tone, Δf = 1 MHz, 4.8 GHz	30	34		dBm
Noise Figure	At 3.5 GHz or 4.8 GHz		1.5		dB
Device Current, ON	V <sub>DD1</sub> and V <sub>DD2</sub>	70	96	130	mA
Device Current, OFF	V <sub>PD</sub> = 0 V		2		mA
V <sub>PD</sub> , Logic Low		0		0.63	V
V <sub>PD</sub> , Logic High		1.17		V <sub>DD</sub>	V
Device ON or OFF Timing	10%-90% Rising or 90%-10% Falling		0.2		μs
Thermal Resistance, θ <sub>Jc</sub>	Junction to case			50.1	°C/W

Notes:

1. Test conditions unless otherwise noted: V<sub>DD1</sub> and V<sub>DD</sub> on EVB = +5.0 V, V<sub>PD</sub> = +1.8 V, Temp = +25 °C, 50 Ω system.

## Logic Table

Parameter, V <sub>PD</sub>	High	Low
Device State	ON	OFF

### 3300 to 5000MHz Evaluation Board - QPA9120EVB01

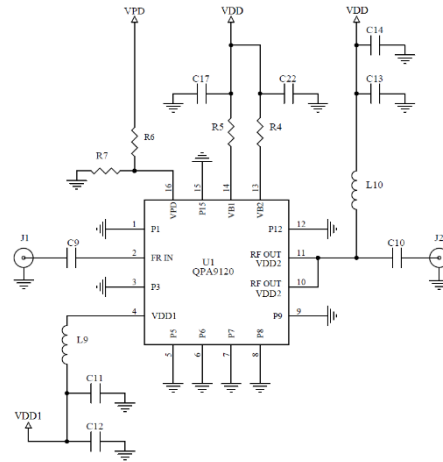
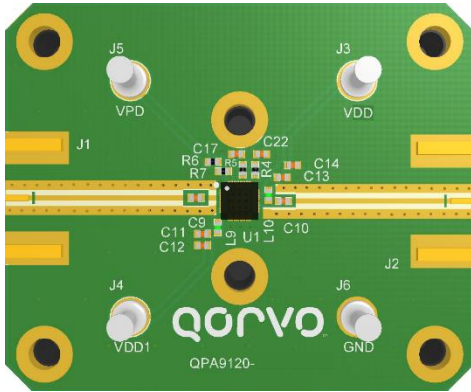

- Notes:
1. See Evaluation Board PCB Information for material and stack up
  2. Total operation current can be adjusted by changing the values of R4 and/or R5

### Bill of Material

Ref. Des.	Value	Description	Manuf.	Part Number
n/a	-	Printed Circuit Board	Qorvo	
U1	-	High Gain High Linearity Amplifier	Qorvo	QPA9120
R4	1.6 KΩ	Res, 1.6 KΩ, 0402, 1%, 1/16W	various	
R5	5.62 KΩ	Res, 5.62 KΩ, 0603, 1%, 1/16W	various	
R6	0 Ω	Res, 0 Ω, 0402, 1/10W	various	
R7	100 KΩ	Res, 100 KΩ, 0402, 5%, 1/16W	various	
C9, C10	18 pF	Cap, 18 pF, 0402, 5%, 50V NPO/C0G	various	
C11, C13, C17, C22	100 pF	Cap, 100 pF, 0402, 5%, 50V NPO/C0G	various	
C12, C14	1.0 μF	Cap, 1.0 μF, 0402, 10%, 10V, X5R	various	
L9, L10 <sup>(1)</sup>	2.2 nH	Inductor, 2.2 nH, 0402, ±0.1nH	muRata	LQP15MN2N2B02D
J1, J2	-	Conn, SMA F STRT .062"	Cinch Connectivity	142-0701-851

- Notes:
1. L10 value needs to be 18 nH for operation frequency < 3 GHz

### Typical Performance on EVB

Parameter	Conditions	Typical Value				Units
		1800	2600	3500	4800	
Frequency		1800	2600	3500	4800	MHz
Gain		32.2	30.5	28.3	27.6	dB
Input Return Loss		6	10	13	11	dB
Output Return Loss		24	14	15	12	dB
Output P1dB		21.5	22.0	21.9	21.3	dBm
Output IP3	Pout = +2 dBm/tone, Δf = 1 MHz	31.9	33.1	35.4	34.4	dBm
Device Current	V <sub>DD</sub> and V <sub>DD1</sub>	96				mA

- Notes:
1. Test Conditions unless otherwise noted: V<sub>DD1</sub> and V<sub>DD</sub> on EVB = +5.0V, V<sub>PD</sub> = +1.8 V, Temp. = +25 °C, L10 = 18 nH on EVB for Freq. < 3 GHz

Performance Plots – QPA9120EVB01

Test conditions unless otherwise noted:  $V_{DD1}$  and  $V_{DD}$  on EVB = +5.0 V,  $I_{DD}$  = 96 mA,  $V_{PD}$  = +1.8 V, Temp. = +25 °C

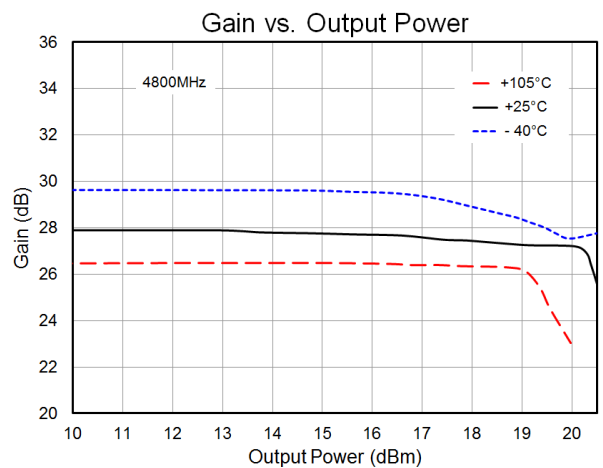
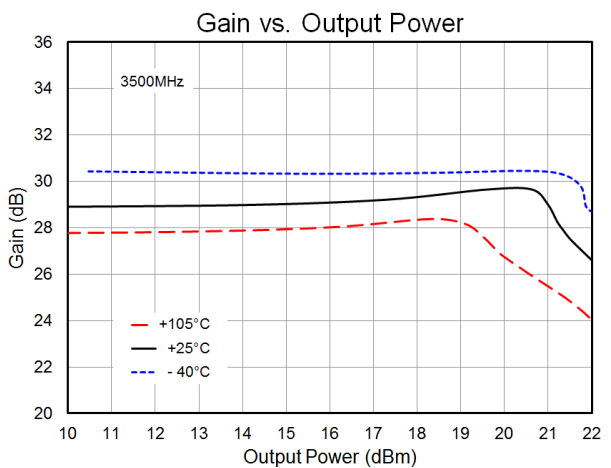
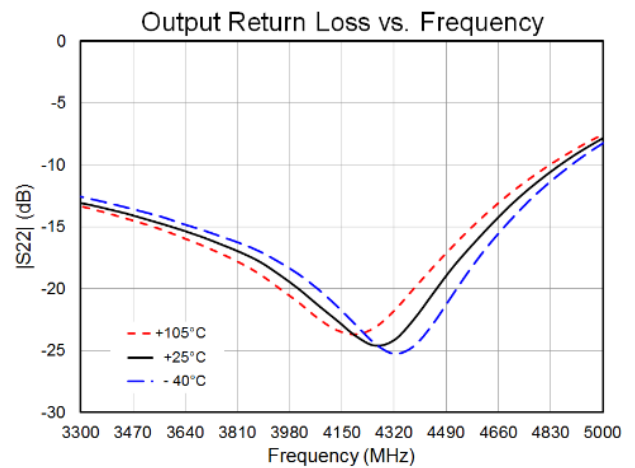
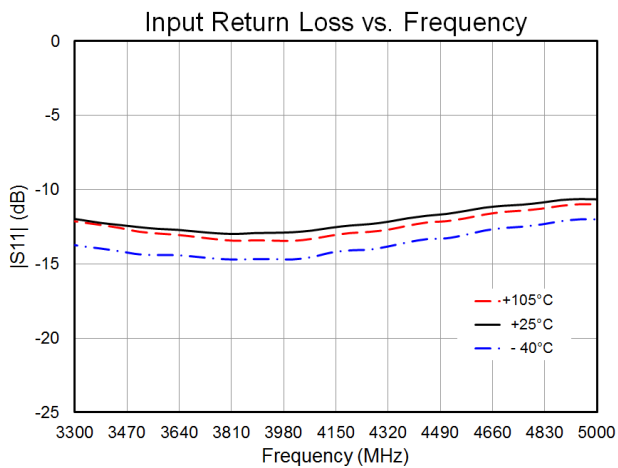
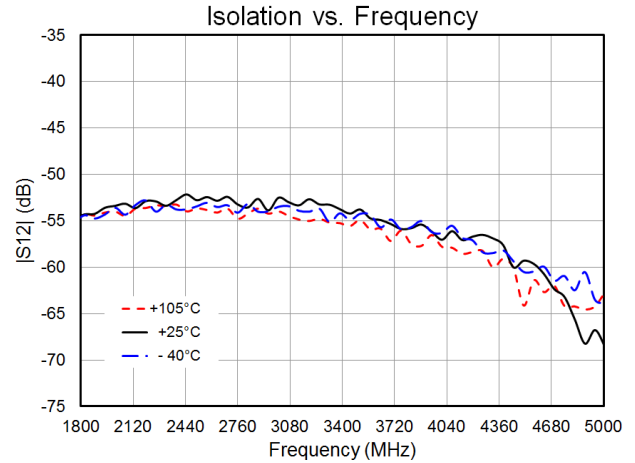
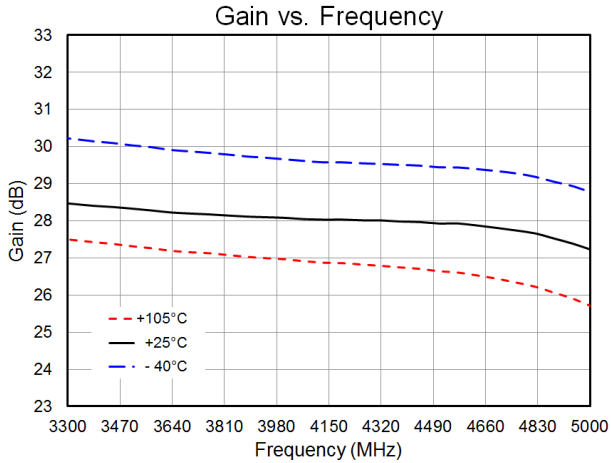

Performance Plots – QPA9120EVB01 (Continue)

Test conditions unless otherwise noted:  $V_{DD1}$  and  $V_{DD} = +5.0V$ ,  $I_{DD} = 96\text{ mA}$ ,  $V_{PD} = +1.8V$ , Temp. =  $+25^\circ\text{C}$

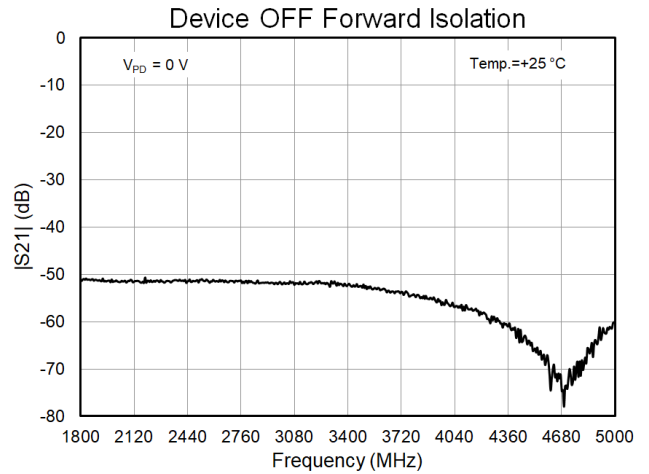
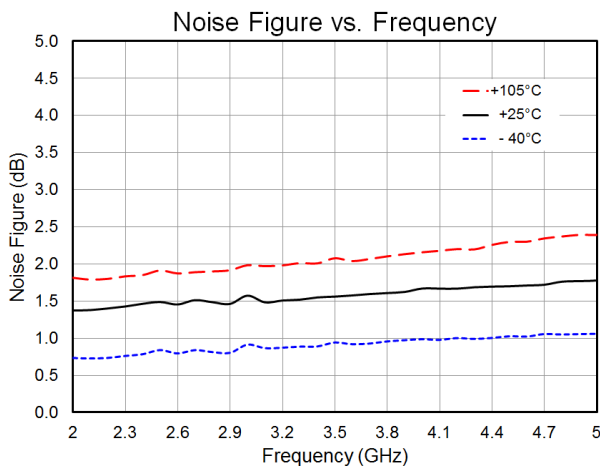
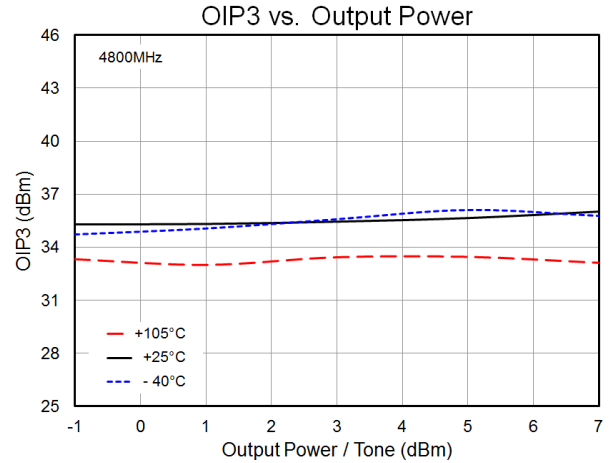
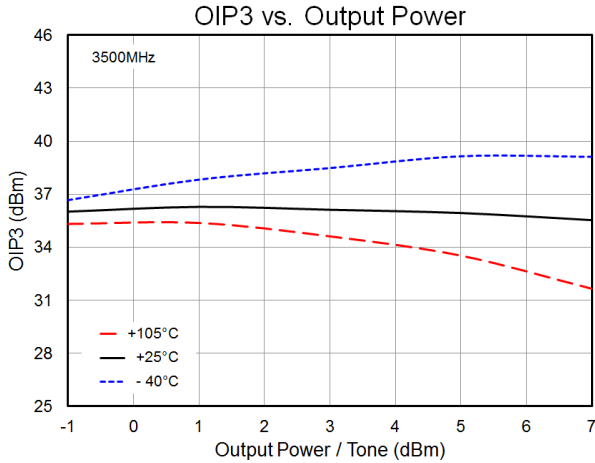

**Performance Plots – 1800 MHz to 2700MHz**

Test conditions unless otherwise noted:  $V_{DD1}$  and  $V_{DD}$  on EVB = +5V,  $I_{DD}$  = 96 mA,  $V_{PD}$  = +1.8 V, Temp.=+25 °C, L10 = 18 nH on QPA9120EVB01

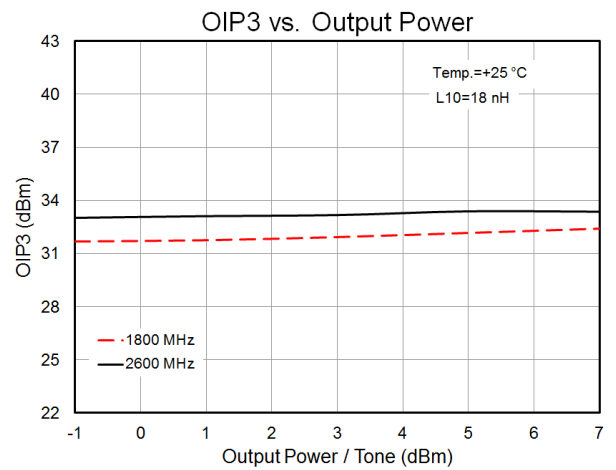
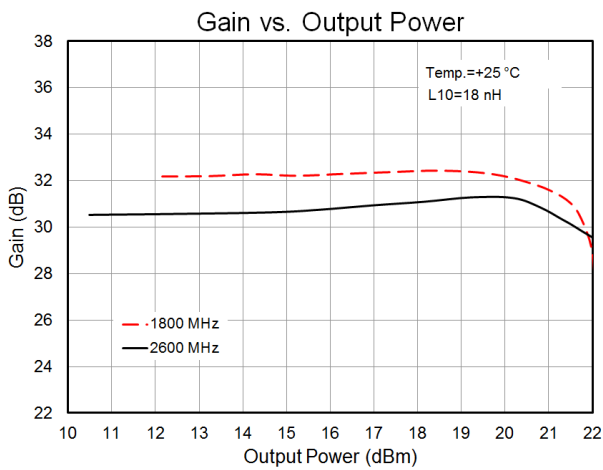
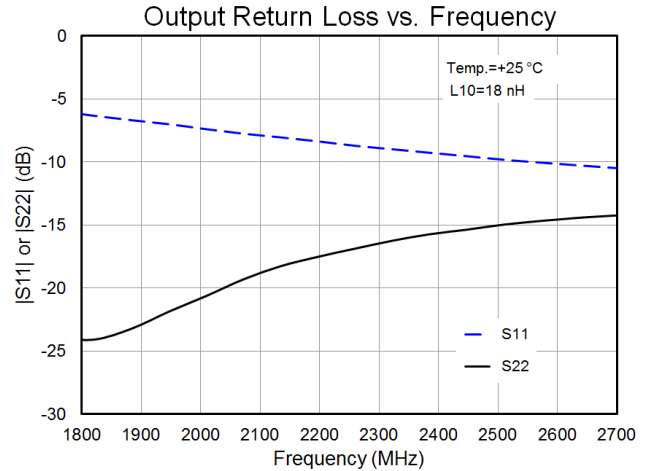
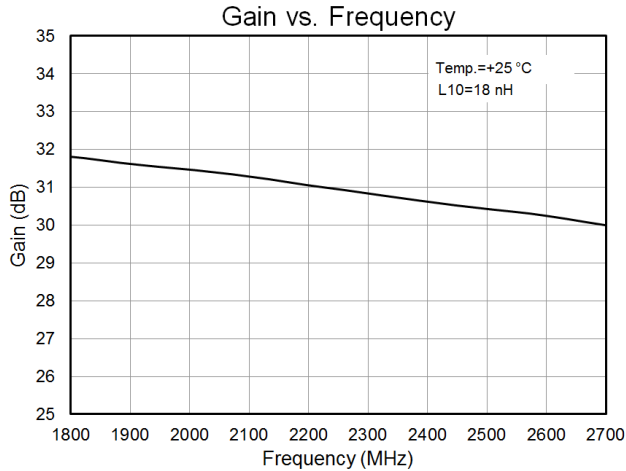

**Evaluation Board PCB Information**

**PC Board Layout**

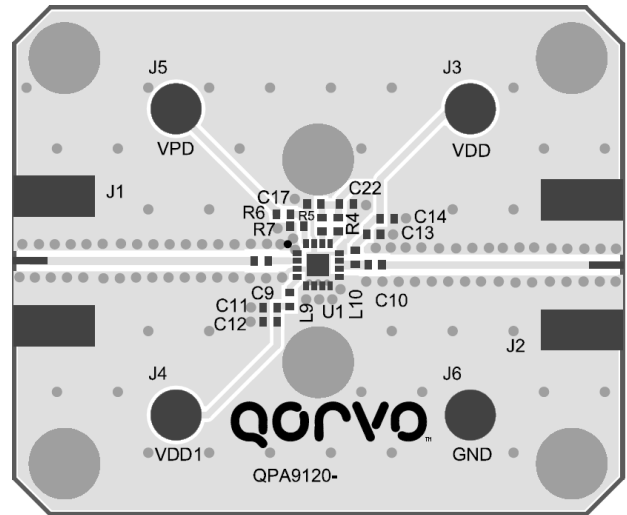
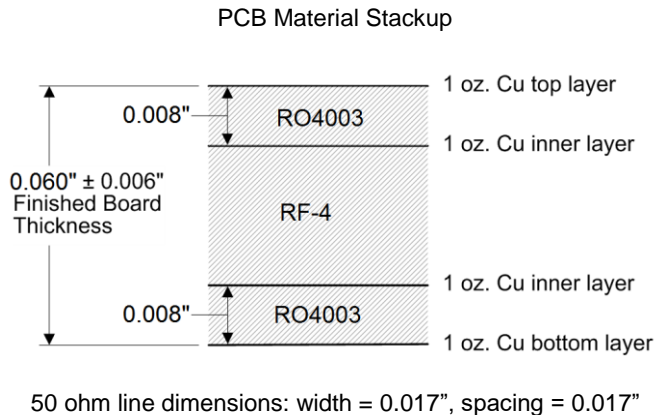

## Pad Configuration and Description

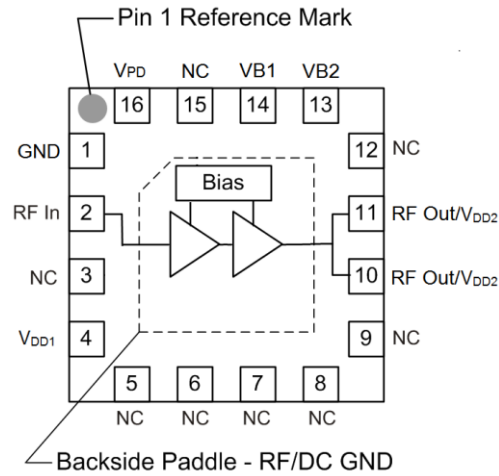

Top View

Pad No.	Label	Description
1	GND	Ground connection
2	RF IN	RF input. External DC Block required
3, 5, 6, 7, 8, 9, 12, 15	NC	No electrical connection internally. It may be left floating or connected to ground. Land pads should be provided for PCB mounting integrity.
4	V <sub>DD1</sub>	The first stage DC supply. External choke required
10, 11	RF OUT / V <sub>DD2</sub>	RF output and the second stage DC supply. External chock and DC Block capacitor required.
13	VB2	Sets the bias current for the second stage of the amplifier
14	VB1	Sets the bias current for the first stage of the amplifier
16	V <sub>PD</sub>	Amplifier ON/OFF logic control
Backside Paddle	GND	RF/DC ground. Use recommended via pattern to minimize inductance and thermal resistance. See PCB Mounting Pattern for suggested footprint.



## Package Marking and Dimensions

Marking: Pin 1 marker – Dot and Logo – Q  
 Part Number – 9120  
 Trace Code – XXXX up to 4 Characters assigned by sub-contractor

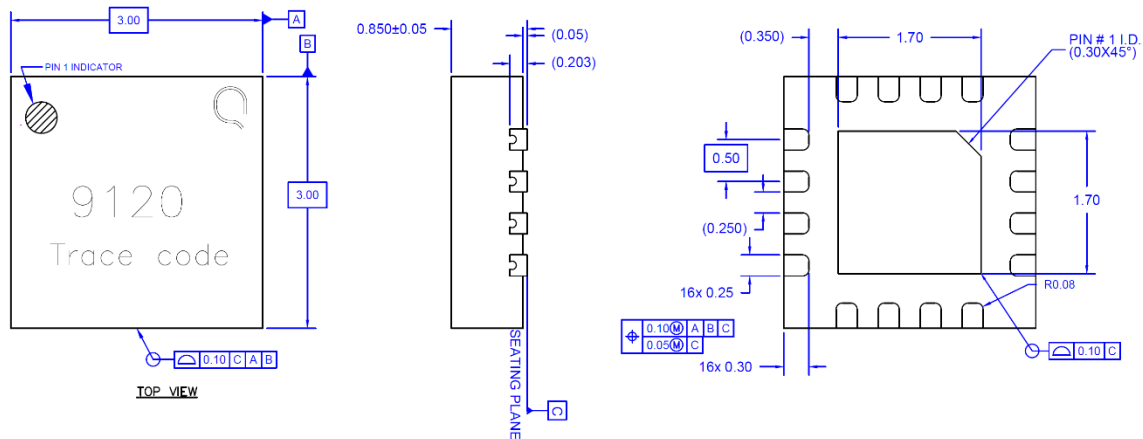

- Notes:
1. All dimensions are in millimeters. Angles are in degrees.
  2. The terminal #1 identifier and terminal numbering conform to JESD 95-1 SPP-012.
  3. Contact plating: NiPdAu

## Recommended PCB Layout Pattern

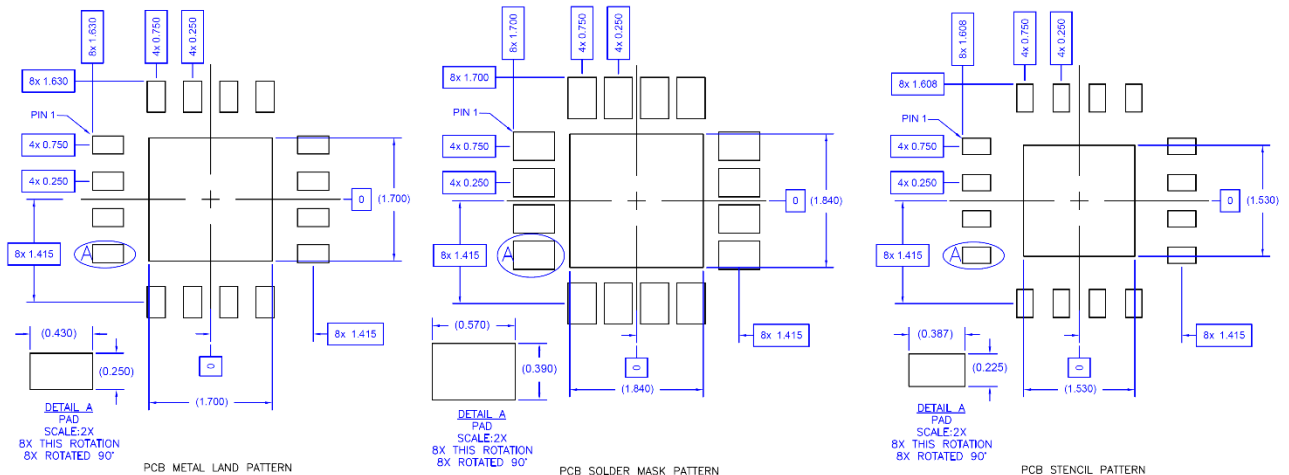

- Notes:
1. All dimensions are in millimeters. Angles are in degrees.
  2. Use 1 oz. copper minimum for top and bottom layer metal.
  3. Via holes are required under the backside paddle of this device for proper RF/DC grounding and thermal dissipation. We recommend a 0.35mm (#80/.0135") diameter bit for drilling via holes and a final plated thru diameter of 0.25 mm (0.01").
  4. Ensure good package backside paddle solder attach for reliable operation and best electrical performance.

**Tape and Reel Information – Carrier and Cover Tape Dimensions**

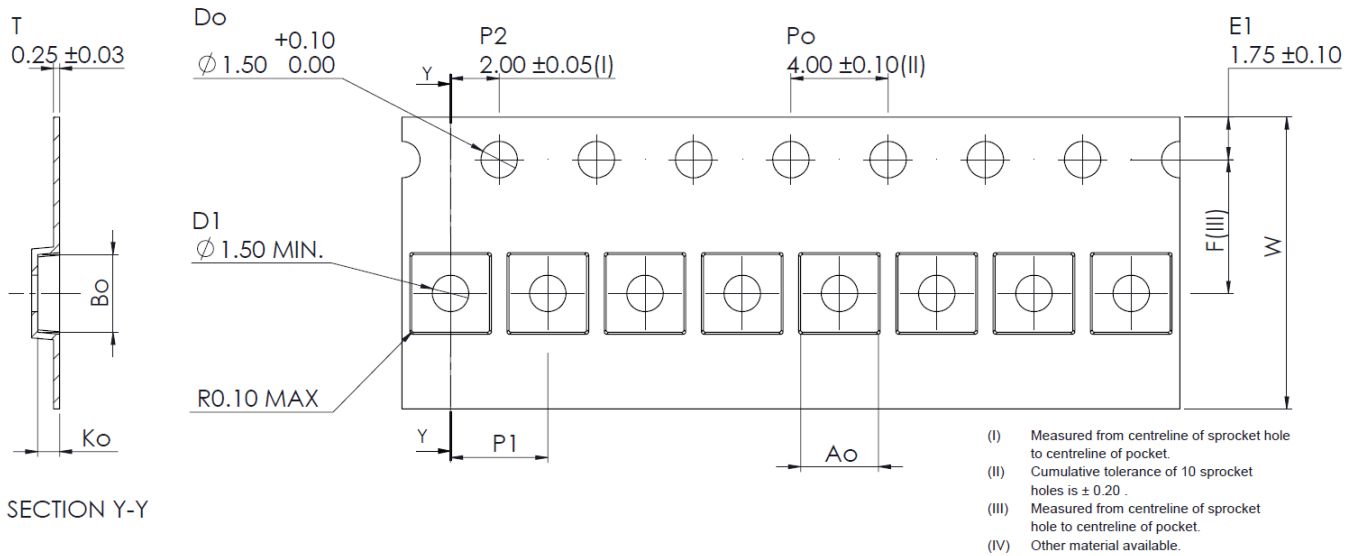
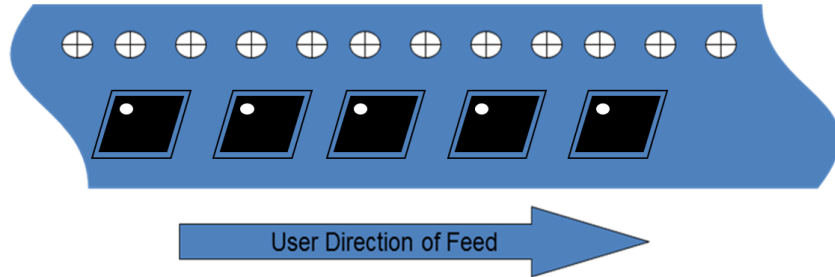

Feature	Measure	Symbol	Size (in)	Size (mm)
Cavity	Length	A0	0.126	3.20
	Width	B0	0.126	3.20
	Depth	K0	0.039	1.00
	Pitch	P1	0.157	4.00
Centerline Distance	Cavity to Perforation - Length Direction	P2	0.079	2.00
	Cavity to Perforation - Width Direction	F	0.217	5.50
Cover Tape	Width	C	0.362	9.20
Carrier Tape	Width	W	0.472	12.00

**Tape and Reel Information – Reel Dimensions**

Standard T/R size = 2,500 pieces on a 7" reel.

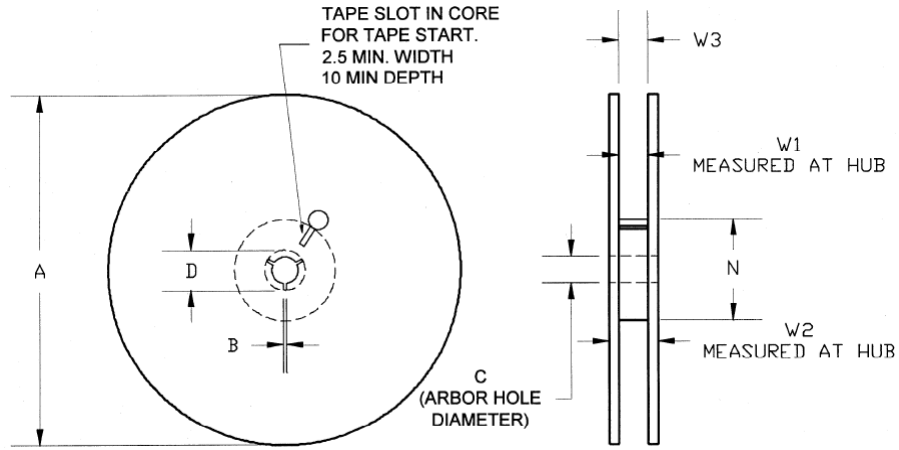

Feature	Measure	Symbol	Size (in)	Size (mm)
Flange	Diameter	A	6.969	177.0
	Thickness	W2	0.717	18.2
	Space Between Flange	W1	0.504	12.8
Hub	Outer Diameter	N	2.283	58.0
	Arbor Hole Diameter	C	0.512	13.0
	Key Slit Width	B	0.079	2.0
	Key Slit Diameter	D	0.787	20.0

**Tape and Reel Information – Tape Length and Label Placement**

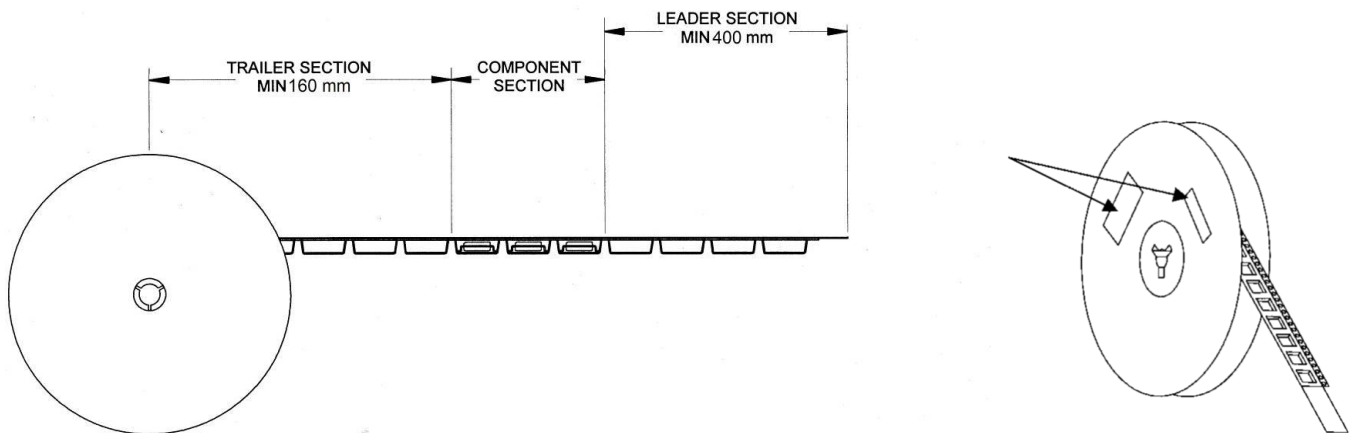

- Notes:
1. Empty part cavities at the trailing and leading ends are sealed with cover tape. See EIA 481-1-A.
  2. Labels are placed on the flange opposite the sprockets in the carrier tape.

## Handling Precautions

Parameter	Rating	Standard
ESD – Human Body Model (HBM)	Class 1A	ESDA / JEDEC JS-001-2012
ESD – Charged Device Model (CDM)	Class C3	JEDEC JESD22-C101F
MSL – Moisture Sensitivity Level	Level 1	IPC/JEDEC J-STD-020



Caution!  
ESD-Sensitive Device

## Solderability

Compatible with both lead-free (260°C max. reflow temperature) and tin/lead (245°C max. reflow temperature) soldering processes. Solder profiles available upon request.

Contact plating: NiPdAu

## RoHS Compliance

This part is compliant with 2011/65/EU RoHS directive (Restrictions on the Use of Certain Hazardous Substances in Electrical and Electronic Equipment) as amended by Directive 2015/863/EU.

This product also has the following attributes:

- Lead Free
- Halogen Free (Chlorine, Bromine)
- Antimony Free
- TBBP-A (C<sub>15</sub>H<sub>12</sub>Br<sub>4</sub>O<sub>2</sub>) Free
- PFOS Free
- SVHC Free



## Contact Information

For the latest specifications, additional product information, worldwide sales and distribution locations:

**Web:** [www.qorvo.com](http://www.qorvo.com)

**Tel:** 1-844-890-8163

**Email:** [customer.support@qorvo.com](mailto:customer.support@qorvo.com)

For technical questions and application information

**Email:** [appsupport@qorvo.com](mailto:appsupport@qorvo.com)

## Important Notice

The information contained herein is believed to be reliable; however, Qorvo makes no warranties regarding the information contained herein and assumes no responsibility or liability whatsoever for the use of the information contained herein. All information contained herein is subject to change without notice. Customers should obtain and verify the latest relevant information before placing orders for Qorvo products. The information contained herein or any use of such information does not grant, explicitly or implicitly, to any party any patent rights, licenses, or any other intellectual property rights, whether with regard to such information itself or anything described by such information. **THIS INFORMATION DOES NOT CONSTITUTE A WARRANTY WITH RESPECT TO THE PRODUCTS DESCRIBED HEREIN, AND QORVO HEREBY DISCLAIMS ANY AND ALL WARRANTIES WITH RESPECT TO SUCH PRODUCTS WHETHER EXPRESS OR IMPLIED BY LAW, COURSE OF DEALING, COURSE OF PERFORMANCE, USAGE OF TRADE OR OTHERWISE, INCLUDING THE IMPLIED WARRANTIES OF MERCHANTABILITY AND FITNESS FOR A PARTICULAR PURPOSE.**

Without limiting the generality of the foregoing, Qorvo products are not warranted or authorized for use as critical components in medical, life-saving, or life-sustaining applications, or other applications where a failure would reasonably be expected to cause severe personal injury or death.

Copyright 2019 © Qorvo, Inc. | Qorvo is a registered trademark of Qorvo, Inc.



## Стандарт Электрон Связь

Мы молодая и активно развивающаяся компания в области поставок электронных компонентов. Мы поставляем электронные компоненты отечественного и импортного производства напрямую от производителей и с крупнейших складов мира.

Благодаря сотрудничеству с мировыми поставщиками мы осуществляем комплексные и плановые поставки широчайшего спектра электронных компонентов.

Собственная эффективная логистика и склад в обеспечивает надежную поставку продукции в точно указанные сроки по всей России.

Мы осуществляем техническую поддержку нашим клиентам и предпродажную проверку качества продукции. На все поставляемые продукты мы предоставляем гарантию .

Осуществляем поставки продукции под контролем ВП МО РФ на предприятия военно-промышленного комплекса России , а также работаем в рамках 275 ФЗ с открытием отдельных счетов в уполномоченном банке. Система менеджмента качества компании соответствует требованиям ГОСТ ISO 9001.

Минимальные сроки поставки, гибкие цены, неограниченный ассортимент и индивидуальный подход к клиентам являются основой для выстраивания долгосрочного и эффективного сотрудничества с предприятиями радиоэлектронной промышленности, предприятиями ВПК и научно-исследовательскими институтами России.

С нами вы становитесь еще успешнее!

### Наши контакты:

**Телефон:** +7 812 627 14 35

**Электронная почта:** [sales@st-electron.ru](mailto:sales@st-electron.ru)

**Адрес:** 198099, Санкт-Петербург,  
Промышленная ул, дом № 19, литера Н,  
помещение 100-Н Офис 331