

RFMD 
RF5521

RF5521
RFMD

Package Style: QFN, 10-pin, 1.75mmx1.75mmx0.5mm



Features

- Single Supply Voltage 3.0V to 4.5V
- Integrated SP3T Switch and LNA with Bypass
- Typical gain is 12dB and 2.0dB NF in RX Mode Pin-to-Pin

Applications

- IEEE802.11b/g/n WiFi Applications
- Portable Battery-Powered Equipment
- WiFi/Bluetooth® Combination Devices

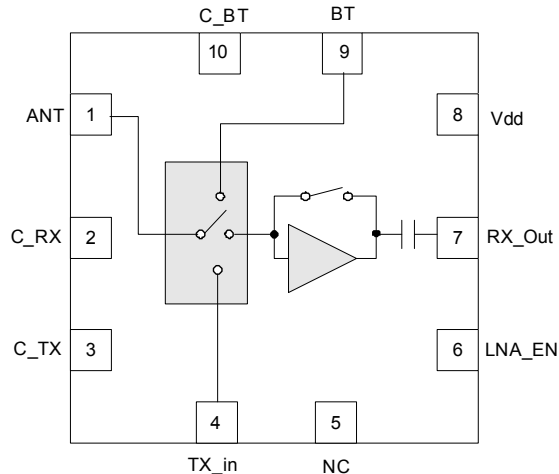

Functional Block Diagram

Product Description

The RF5521 is designed specifically for high-performance WiFi applications in the 2.4GHz to 2.5GHz ISM band, including Personal Media Players (PMPs), digital cameras, and WiFi enabled handsets.

The RF5521 integrates the LNA with bypass and an SP3T switch of a Front-End solution for WiFi and Bluetooth® combination systems. The integrated input and output match reduces the number of external components, keeping cost down and utilizing minimum layout area for implementation. The RF5521 is provided in an ultra small 1.75 mmx1.75mmx0.5mm 10-pin QFN package. This LNA+Switch front-end solution meets or exceeds the specification requirements of IEEE 802.11 b/g/n WiFi RF systems.

Ordering Information

RF5521	Standard 25 piece bag
RF5521SR	Standard 100 piece reel
RF5521TR7	Standard 2500 piece reel
RF5521PCK-410	Fully Assembled Evaluation Board

Absolute Maximum Ratings

Parameter	Rating	Unit
DC Supply Voltage	5.5	V
Stability, Output VSWR	5:1	
Antenna Port Nominal Impedance	50	Ω
Full Spec Compliant Temperature Range	-10 to +75	$^{\circ}\text{C}$
Storage Temperature	-40 to +150	$^{\circ}\text{C}$
Moisture Sensitivity Level	MSL2	
LNA Input Power (no damage)	5	dBm



Caution ESD sensitive device.

Exceeding any one or a combination of the Absolute Maximum Rating conditions may cause permanent damage to the device. Extended application of Absolute Maximum Rating conditions to the device may reduce device reliability. Specified typical performance or functional operation of the device under Absolute Maximum Rating conditions is not implied.

RoHS status based on EU Directive 2011/65/EU (at time of this document revision).

The information in this publication is believed to be accurate and reliable. However, no responsibility is assumed by RF Micro Devices, Inc. ("RFMD") for its use, nor for any infringement of patents, or other rights of third parties, resulting from its use. No license is granted by implication or otherwise under any patent or patent rights of RFMD. RFMD reserves the right to change component, circuitry, recommended application circuitry and specifications at any time without prior notice.

Parameter	Specification			Unit	Condition
	Min.	Typ.	Max.		
Compliance					IEEE802.11b/g/n, FCC CFR 15.247, .205, .209, EN & JDEC. VDD=3.3V, LNA_EN=2.85V, Temp=+25 $^{\circ}\text{C}$, Freq=2.4GHz to 2.5GHz, unless noted otherwise.
Operating Frequency	2.4		2.5	GHz	
LNA Voltage Supply (V_{DD})	3.0	3.3	4.5	V	
LNA Enable Voltage (LNA_En)	2.70	2.85	4.5	V	LNA Enabled
	0		0.2	V	LNA Off.
Switch Control Voltage "HIGH"	2.4		4.5	V	
Switch Control Voltage "LOW"			0.2	V	
LNA Bypass (LNA_EN)	2.7		4.5	V	LNA Bypass Disabled
			0.2	V	LNA Bypass Enabled
LNA Current					
LNA V_{DD}	4.5	7	14	mA	LNA in "On" state.
			5	μA	LNA in "Off" state.
LNA Enable			1	mA	LNA Enabled.
LNA Bypass			1	mA	LNA Bypass Mode.
Gain, WiFi Rx	9	12	14	dB	WiFi ANT-RX, (LNA_EN High)
Bypass Mode	-5.0	-4.0	-3.0	dB	WiFi ANT-RX, (LNA_EN Low)
Noise Figure					VDD > 3.0V, including switch
WiFi Rx		2.0	3.0	dB	WiFi RX Mode.
Bypass Mode		4.0	5.0	dB	LNA Bypass.
Passband Ripple	-0.2		+0.2	dB	WiFi RX Mode.
	-0.2		+0.2	dB	WiFi ANT-BT
Output Return Loss	7.5	12	20	dB	LNA ON
WiFi Input/Output Impedance		50		Ω	No external matching.

Parameter	Specification			Unit	Condition
	Min.	Typ.	Max.		
BT and TX Switch Parameters					
Frequency	2.4		2.5	GHz	
TX Insertion Loss		0.6	1.0	dB	ANT-BT, TX-ANT
		3.8	4.0	dB	C_BT (ANT-BT) and C_RX (ANT-RX) On simultaneously.
BT Insertion Loss		0.9	1.2	dB	ANT-BT
		3.8	4.0	dB	C_BT (ANT-BT) and C_RX (ANT-RX) On simultaneously.
Passband Ripple	-0.2		+0.2	dB	
Input P1dB		28		dBm	Switch ports only.
TX Output Power	21	23		dBm	C_TX>3.0V; 1% composite EVM (note 1)
Input Return Loss	9	10	20	dB	BT input (pin-1) and TX input (pin-4)
Output Return Loss	9	10	20	dB	BT output (pin-9) and TX output (pin-1)
Current Consumption			10	μA	Switch Leakage Current
Port Impedance					All ports.
Input		50		Ω	Receive
Output		50		Ω	Transmit
Isolation	18	20	28	dB	TX-BT (ANT to BT port in TX mode); and TX-RX (ANT to RX port in TX mode)
Switch Control Voltage					
High	2.5		4.5	V	C_TX, C_RX, C_BT
Low			0.2	V	
Switch Control Current			20	μA	Per control line.
Switch Control Speed		50		nsec	
ESD Human Body Model (HBM)	500			V	Class 1B; JESD22-A114
ESD Charge Device Model (CDM)	650			V	Class III; JESD22-C101

Note 1: Assumes system EVM<0.5% for input signal.

Switch Control Logic

MODE	Switch Controls			
	C BT	C RX	C TX	LNA EN
WiFi Receive	LOW	HIGH	LOW	HIGH
WiFi Bypass	LOW	HIGH	LOW	LOW
Bluetooth®	HIGH	LOW	LOW	LOW
WiFi Transmit	LOW	LOW	HIGH	LOW
Simultaneous WiFi/BT Receive	HIGH	HIGH	LOW	HIGH

*The FEM can be placed in receive WiFi and Bluetooth® modes simultaneously with increased insertion loss.

Pin	Function	Description
1	ANT	This is a common port (antenna). It is matched at 50Ω.
2	C_RX	Receive mode control voltage. See switch truth table for proper level.
3	C_TX	Transmit mode control voltage. See switch truth table for proper level.
4	TX IN	RF input for the 802.11 b/g PA. Input is matched to 50Ω.
5	NC	No connect pin.
6	LNA_EN	This pin enables the LNA. A logic HIGH enables the LNA.
7	RX_OUT	Receive port for 802.11 b/g band. Internally matched to 50Ω. DC-block provided internally.
8	VDD	Supply voltage to the LNA.
9	BT	RF bi-directional ports for Bluetooth™. Input is matched to 50Ω.
10	C_BT	Bluetooth™ mode control voltage. See switch truth table for proper level.

Package Drawing

Top View

Note: Pads are NiPdAu plated.

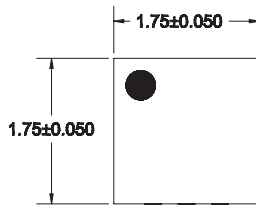

TOP VIEW

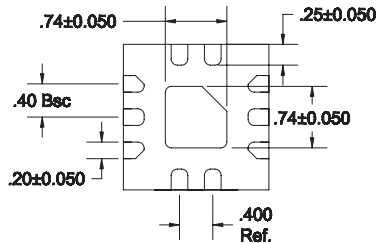

BOTTOM VIEW

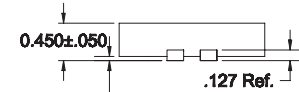

SIDE VIEW

PCB Metal Land Pattern

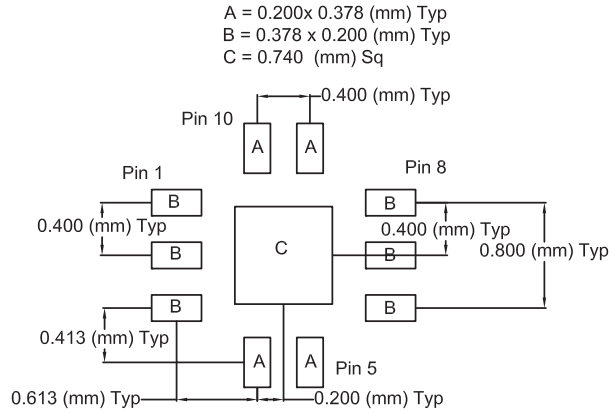

PCB Solder Mask Pattern

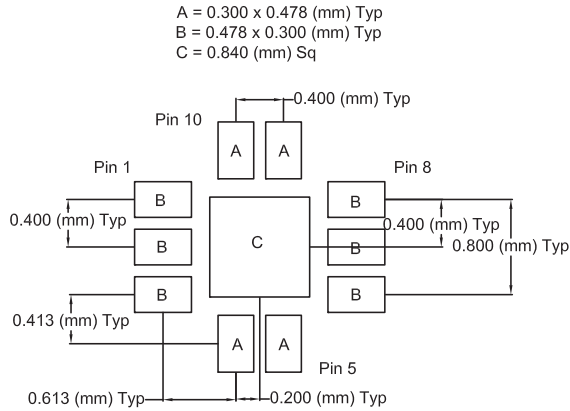

PCB Stencil Pattern

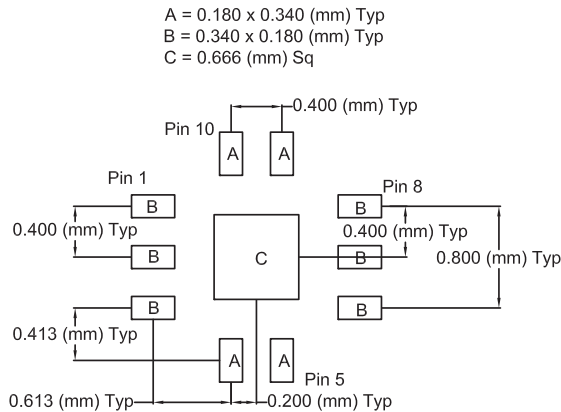

Pin Out Top View

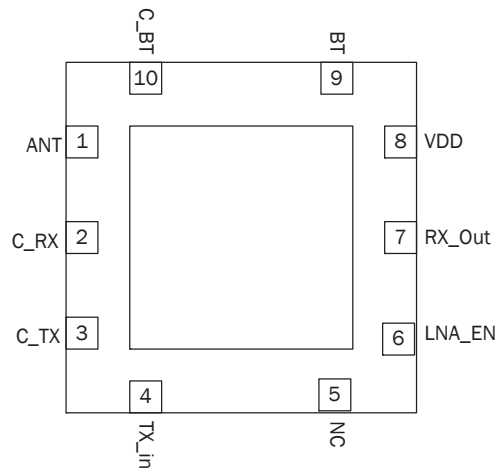

Evaluation Board Schematic

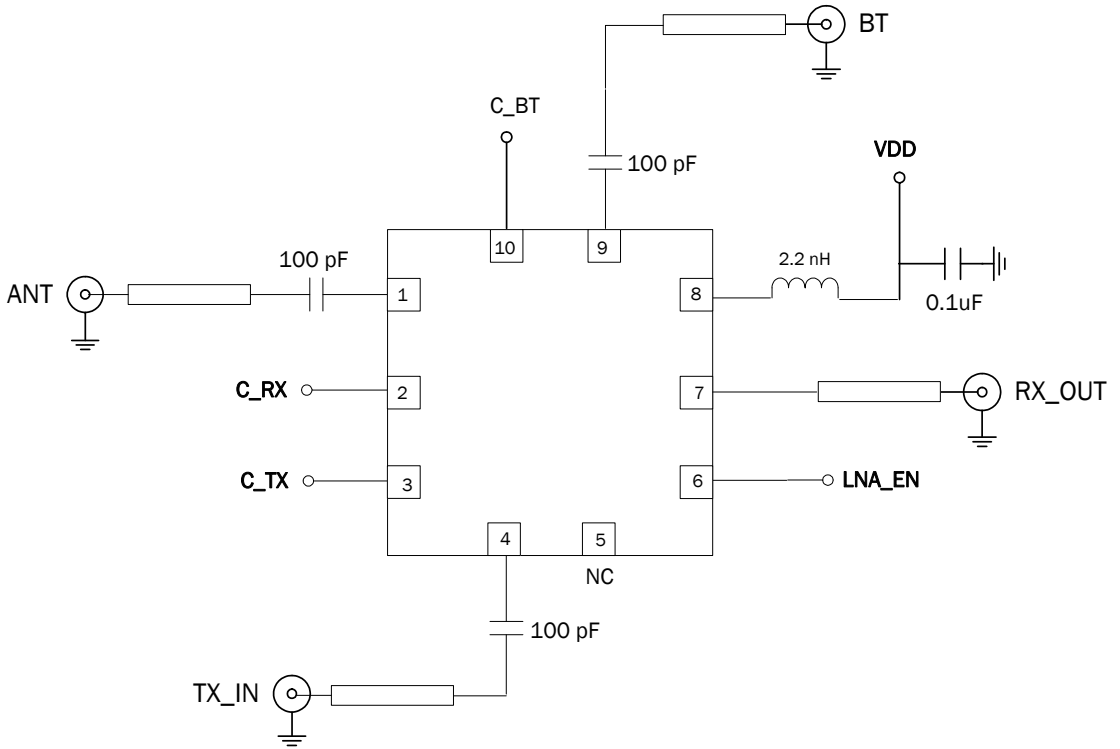

Evaluation Board Layout

Board size: 1.5" x 1.5", Board thickness: 0.032", Board Material FR-4, Multi-Layer

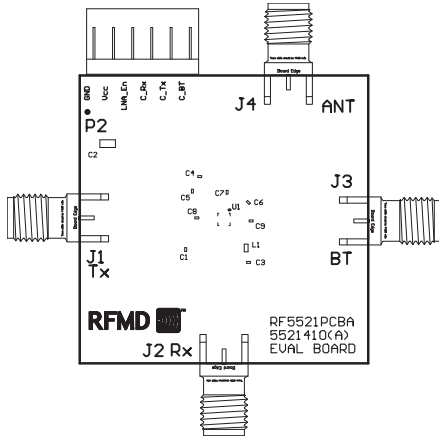

Top Silk

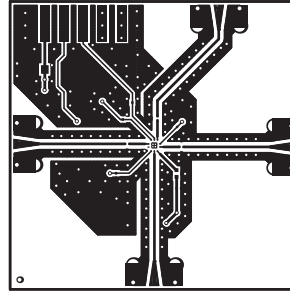

Top Signal

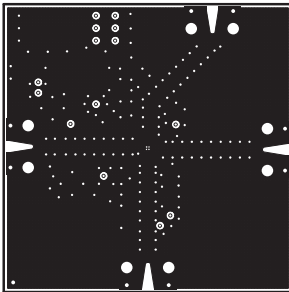

Mid-1

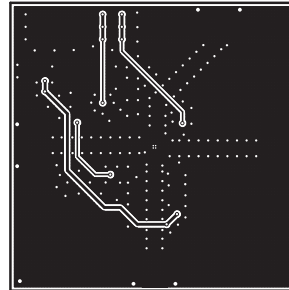

Bottom

RF5521: GAIN versus FREQUENCY and TEMPERATURE
(Vdd=3.3v, LNA_EN=2.8v, C_RX=2.8v, C_TX=0v, C_BT=0v)

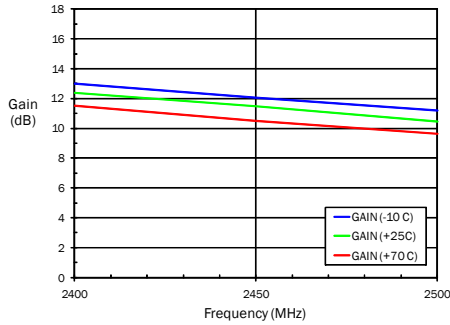

RF5521: NF versus FREQUENCY and TEMPERATURE
(Vdd=3.3v, LNA_EN=2.8v, C_RX=2.8v, C_TX=0v, C_BT=0v)

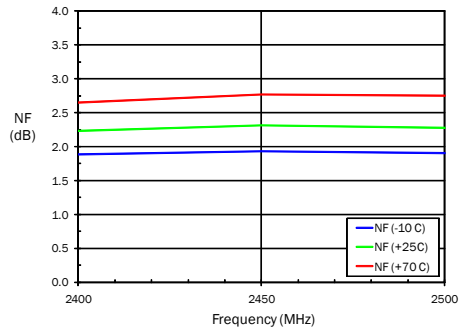

RF5521: INPUT IP3 versus FREQUENCY and TEMPERATURE
(Vdd=3.3v, LNA_EN=2.8v, C_RX=2.8v, C_TX=0v, C_BT=0v)

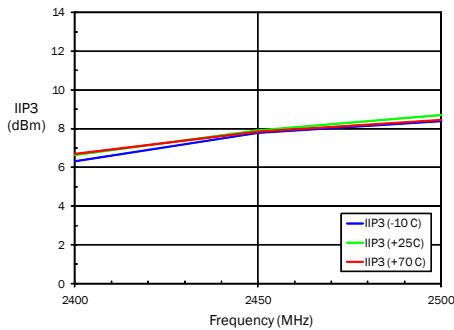

RF5521: CURRENT versus FREQUENCY and TEMPERATURE
(Vdd=3.3v, LNA_EN=2.8v, C_RX=2.8v, C_TX=0v, C_BT=0v)

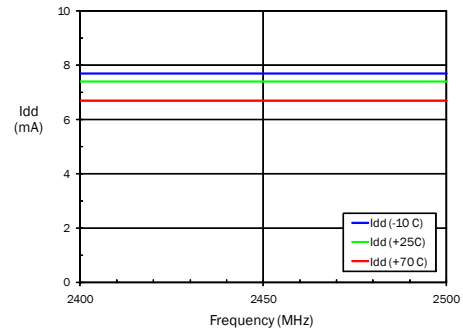

RF5521: BYPASS MODE INSERTION LOSS versus FREQUENCY and TEMPERATURE
(Vdd=3.3v, C_RX=2.8v, LNA_EN=0v, C_TX=0v, C_BT=0v)

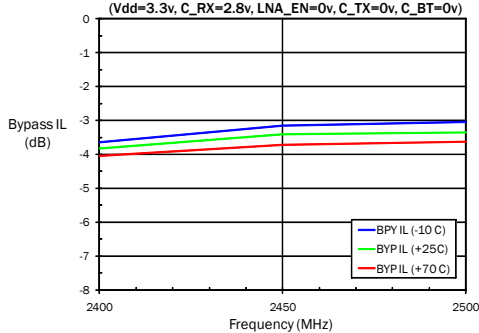

RF5521: TRANSMIT MODE INSERTION LOSS versus FREQUENCY and TEMPERATURE
(Vdd=3.3v, C_TX=2.8v, C_RX=0v, C_BT=0v)

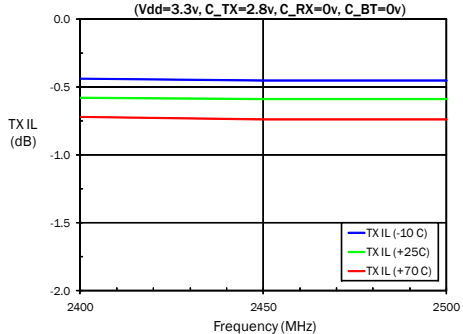

RF5521: BLUETOOTH MODE INSERTION LOSS versus FREQUENCY and TEMPERATURE
(Vdd=3.3v, C_BT=2.8v, C_RX=0v, C_TX=0v)

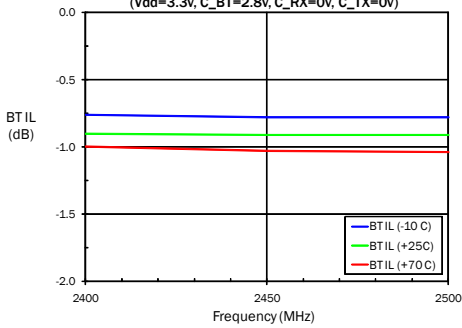

RF5521: TRANSMIT TO RECEIVE ISOLATION versus FREQUENCY and TEMPERATURE
(Vdd=3.3v, C_TX=2.8v, LNA_EN=0v, C_RX=0v, C_BT=0v)

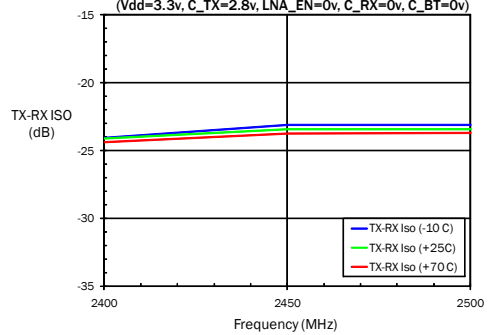

RF5521: TRANSMIT TO BLUETOOTH ISOLATION versus FREQUENCY and TEMPERATURE
(Vdd=3.3v, C_TX=2.8v, C_RX=0v, C_BT=0v)

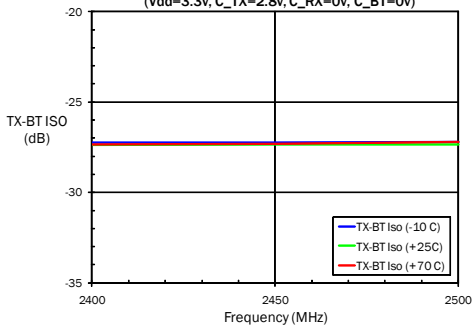



Стандарт Электрон Связь

Мы молодая и активно развивающаяся компания в области поставок электронных компонентов. Мы поставляем электронные компоненты отечественного и импортного производства напрямую от производителей и с крупнейших складов мира.

Благодаря сотрудничеству с мировыми поставщиками мы осуществляем комплексные и плановые поставки широчайшего спектра электронных компонентов.

Собственная эффективная логистика и склад в обеспечивает надежную поставку продукции в точно указанные сроки по всей России.

Мы осуществляем техническую поддержку нашим клиентам и предпродажную проверку качества продукции. На все поставляемые продукты мы предоставляем гарантию .

Осуществляем поставки продукции под контролем ВП МО РФ на предприятия военно-промышленного комплекса России , а также работаем в рамках 275 ФЗ с открытием отдельных счетов в уполномоченном банке. Система менеджмента качества компании соответствует требованиям ГОСТ ISO 9001.

Минимальные сроки поставки, гибкие цены, неограниченный ассортимент и индивидуальный подход к клиентам являются основой для выстраивания долгосрочного и эффективного сотрудничества с предприятиями радиоэлектронной промышленности, предприятиями ВПК и научно-исследовательскими институтами России.

С нами вы становитесь еще успешнее!

Наши контакты:

Телефон: +7 812 627 14 35

Электронная почта: sales@st-electron.ru

Адрес: 198099, Санкт-Петербург,
Промышленная ул, дом № 19, литера Н,
помещение 100-Н Офис 331