

PRECISION, LOW POWER INSTRUMENTATION AMPLIFIERS

Check for Samples: [INA128-HT](#), [INA129-HT](#)

FEATURES ⁽¹⁾

- Low Offset Voltage
- Low Input Bias Current: 50 nA Typ
- High CMR: 95 dB Typ
- Inputs Protected to ± 40 V
- Wide Supply Range: ± 2.25 V to ± 18 V
- Low Quiescent Current: 2 mA Typ

APPLICATIONS

- Bridge Amplifier
- Thermocouple Amplifier
- RTD Sensor Amplifier
- Medical Instrumentation
- Data Acquisition

(1) Typical values for 210°C application

SUPPORTS EXTREME TEMPERATURE APPLICATIONS

- Controlled Baseline
- One Assembly/Test Site
- One Fabrication Site
- Available in Extreme ($-55^{\circ}\text{C}/210^{\circ}\text{C}$) Temperature Range ⁽²⁾
- Extended Product Life Cycle
- Extended Product-Change Notification
- Product Traceability
- Texas Instruments' high temperature products utilize highly optimized silicon (die) solutions with design and process enhancements to maximize performance over extended temperatures.

(2) Custom temperature ranges available

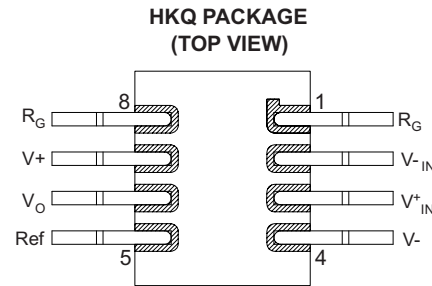
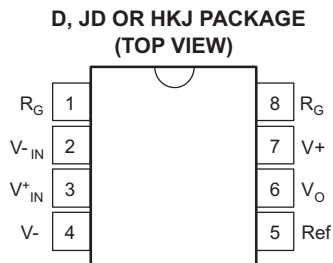

HKQ as formed or HKJ mounted dead bug

DESCRIPTION

The INA128 and INA129 are low power, general purpose instrumentation amplifiers offering excellent accuracy. The versatile three operational amplifier design and small size make them ideal for a wide range of applications. Current-feedback input circuitry provides wide bandwidth even at high gain.

A single external resistor sets any gain from 1 to 10,000. The INA128 provides an industry-standard gain equation; the INA129 gain equation is compatible with the AD620.

The INA128/INA129 is laser trimmed for very low offset voltage (50 μV) and high common-mode rejection (93 dB at $G \geq 100$). It operates with power supplies as low as ± 2.25 V, and quiescent current of 2 mA - typically. Internal input protection can withstand up to ± 40 V without damage.

The INA129 is available in 8-pin ceramic DIP and 8-pin ceramic surface-mount packages, specified for the -55°C to 210°C temperature range. The INA128 is available in an 8-pin SO-8 surface-mount package, specified for the -55°C to 175°C temperature range.



Please be aware that an important notice concerning availability, standard warranty, and use in critical applications of Texas Instruments semiconductor products and disclaimers thereto appears at the end of this data sheet.

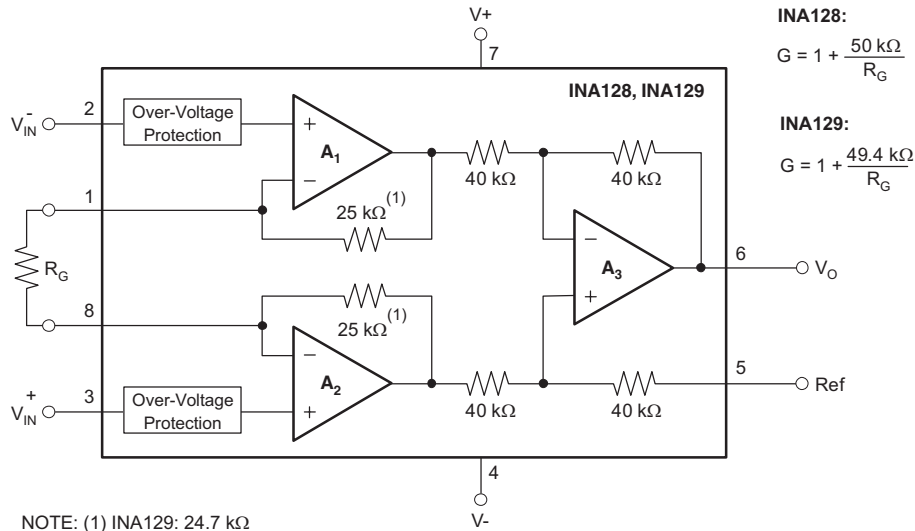

ORDERING INFORMATION

| T _A | PACKAGE | ORDERABLE PART NUMBER | TOP-SIDE MARKING |
|----------------|---------|-----------------------|------------------|
| -55°C to 210°C | HKJ | INA129SHKJ | INA129SHKJ |
| | HKQ | INA129SHKQ | INA129SHKQ |
| | KGD | INA129SKGD1 | NA |
| | JD | INA129SJD | INA129SJD |
| -55°C to 175°C | D | INA128HD | 128HD |

BARE DIE INFORMATION

| DIE THICKNESS | BACKSIDE FINISH | BACKSIDE POTENTIAL | BOND PAD METALLIZATION COMPOSITION |
|---------------|------------------------|--------------------|------------------------------------|
| 15 mils | Silicon with backgrind | GND | Al-Si-Cu (0.5%) |

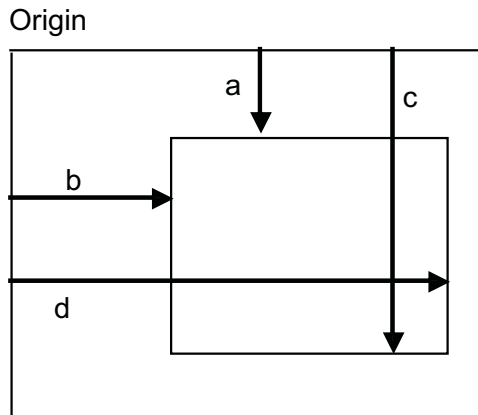
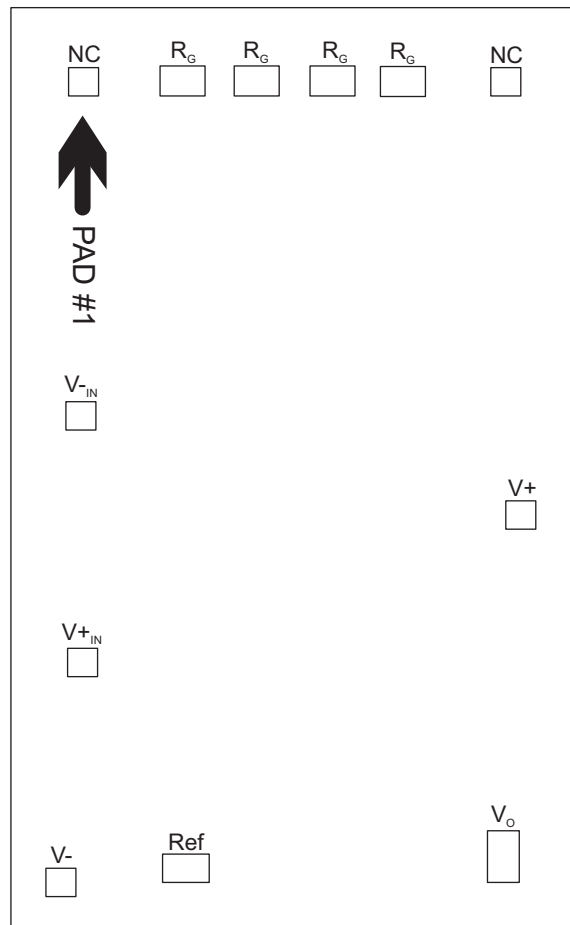

Table 1. Bond Pad Coordinates in Microns

| DISCRIPTION | PAD NUMBER | a | b | c | d |
|------------------|------------|-------|-------|-------|-------|
| NC | 1 | -57.4 | -31.1 | -53.3 | -27 |
| V _{-IN} | 2 | -9.85 | -31.4 | -5.75 | -27.3 |
| V _{+IN} | 3 | 25.05 | -31.4 | 29.15 | -27.3 |
| V ₋ | 4 | 56.2 | -34.3 | 60.3 | -30.2 |
| Ref | 5 | 53.75 | -17.6 | 57.85 | -11 |
| V _O | 6 | 50.35 | 27.8 | 56.95 | 31.9 |
| V ₊ | 7 | 7.75 | 30.2 | 11.85 | 34.3 |
| NC | 8 | -57.4 | 28.4 | -53.3 | 32.5 |
| R _G | 9 | -57.4 | 13.4 | -53.3 | 20 |
| R _G | 10 | -57.5 | 2.7 | -53.4 | 9.3 |
| R _G | 11 | -57.5 | -7.9 | -53.4 | -1.3 |
| R _G | 12 | -57.4 | -18.6 | -53.3 | -12 |



ABSOLUTE MAXIMUM RATINGS⁽¹⁾

over operating free-air temperature range (unless otherwise noted)

| | | VALUE | UNIT |
|------------------|-----------------------------------|-------------------------------|------|
| V _S | Supply voltage | ±18 | V |
| | Analog input voltage range | ±40 | V |
| | Output short-circuit (to ground) | Continuous | |
| T _A | Operating temperature | HKJ, HKQ, KGD and JD packages | °C |
| | | D package | |
| T _{STG} | Storage temperature range | HKJ, HKQ, KGD and JD packages | °C |
| | | D package | |
| | Lead temperature (soldering, 10s) | 300 | °C |

- (1) Stresses above these ratings may cause permanent damage. Exposure to absolute maximum conditions for extended periods may degrade device reliability. These are stress ratings only, and functional operation of the device at these or any other conditions beyond those specified is not implied.

THERMAL CHARACTERISTICS FOR D PACKAGE

| THERMAL METRIC ⁽¹⁾ | | INA128 | UNITS |
|-------------------------------|---|--------|-------|
| | | D | |
| | | 8 PINS | |
| θ _{JA} | Junction-to-ambient thermal resistance ⁽²⁾ | 110 | °C/W |
| θ _{JCtop} | Junction-to-case (top) thermal resistance ⁽³⁾ | 57 | |
| θ _{JB} | Junction-to-board thermal resistance ⁽⁴⁾ | 54 | |
| ψ _{JT} | Junction-to-top characterization parameter ⁽⁵⁾ | 11 | |
| ψ _{JB} | Junction-to-board characterization parameter ⁽⁶⁾ | 53 | |
| θ _{JCbot} | Junction-to-case (bottom) thermal resistance ⁽⁷⁾ | N/A | |

- (1) For more information about traditional and new thermal metrics, see the *IC Package Thermal Metrics* application report, [SPRA953](#).
 (2) The junction-to-ambient thermal resistance under natural convection is obtained in a simulation on a JEDEC-standard, high-K board, as specified in JESD51-7, in an environment described in JESD51-2a.
 (3) The junction-to-case (top) thermal resistance is obtained by simulating a cold plate test on the package top. No specific JEDEC-standard test exists, but a close description can be found in the ANSI SEMI standard G30-88.
 (4) The junction-to-board thermal resistance is obtained by simulating in an environment with a ring cold plate fixture to control the PCB temperature, as described in JESD51-8.
 (5) The junction-to-top characterization parameter, ψ_{JT}, estimates the junction temperature of a device in a real system and is extracted from the simulation data for obtaining θ_{JA}, using a procedure described in JESD51-2a (sections 6 and 7).
 (6) The junction-to-board characterization parameter, ψ_{JB}, estimates the junction temperature of a device in a real system and is extracted from the simulation data for obtaining θ_{JA}, using a procedure described in JESD51-2a (sections 6 and 7).
 (7) The junction-to-case (bottom) thermal resistance is obtained by simulating a cold plate test on the exposed (power) pad. No specific JEDEC standard test exists, but a close description can be found in the ANSI SEMI standard G30-88.

THERMAL CHARACTERISTICS FOR JD PACKAGE

over operating free-air temperature range (unless otherwise noted)

| PARAMETER | | TEST CONDITIONS | MIN | TYP | MAX | UNIT |
|-----------------|---|--|-----|------|-----|------|
| θ _{JA} | Junction-to-ambient thermal resistance ⁽¹⁾ | High-K board ⁽²⁾ , no airflow | | 64.9 | | °C/W |
| | | No airflow | | 83.4 | | |
| θ _{JB} | Junction-to-board thermal resistance | High-K board without underfill | | 27.9 | | °C/W |
| θ _{JC} | Junction-to-case thermal resistance | | | 6.49 | | °C/W |

- (1) The intent of θ_{JA} specification is solely for a thermal performance comparison of one package to another in a standardized environment. This methodology is not meant to and will not predict the performance of a package in an application-specific environment.
 (2) JED51-7, high effective thermal conductivity test board for leaded surface mount packages

THERMAL CHARACTERISTICS FOR HKJ OR HKQ PACKAGE

over operating free-air temperature range (unless otherwise noted)

| PARAMETER | | MIN | TYP | MAX | UNIT |
|---------------|-------------------------------------|---|-----|------|------|
| θ_{JC} | Junction-to-case thermal resistance | to ceramic side of case | | 5.7 | °C/W |
| | | to top of case lid (metal side of case) | | 13.7 | |

ELECTRICAL CHARACTERISTICS FOR INA128
 $T_A = 25^\circ\text{C}$, $V_S = \pm 15\text{ V}$, $R_L = 10\text{ k}\Omega$ (unless otherwise noted)

| PARAMETER | TEST CONDITIONS | $T_A = -55^\circ\text{C to } 125^\circ\text{C}$ | | | $T_A = 175^\circ\text{C}^{(1)}$ | | | UNIT |
|--|--|---|--------------------------------|----------------------------------|---------------------------------|------------------------|--------------------------------|------------------------------|
| | | MIN | TYP | MAX | MIN | TYP | MAX | |
| INPUT | | | | | | | | |
| OFFSET VOLTAGE, RTI | | | | | | | | |
| Initial | $T_A = 25^\circ\text{C}$ | | ± 25 $\pm 100/\text{G}$ | ± 125 $\pm 1000/\text{G}$ | | | | μV |
| vs temperature | $T_A = T_{\text{MIN}} \text{ to } T_{\text{MAX}}$ | | ± 0.2 $\pm 5/\text{G}$ | ± 1 $\pm 20/\text{G}$ | | | ± 3.5 $\pm 80/\text{G}$ | $\mu\text{V}/^\circ\text{C}$ |
| vs power supply | $V_S = \pm 2.25\text{ V to } \pm 18\text{ V}$ | | | ± 2 $\pm 200/\text{G}$ | | | ± 5 $\pm 500/\text{G}$ | $\mu\text{V}/\text{V}$ |
| Long-term stability | | | $\pm 1 \pm 3/\text{G}$ | | | $\pm 1 \pm 3/\text{G}$ | | $\mu\text{V}/\text{mo}$ |
| Impedance, differential | | | $10^{10} \parallel 2$ | | | $10^{10} \parallel 2$ | | $\Omega \parallel \text{pF}$ |
| Common mode | | | $10^{11} \parallel 9$ | | | $10^{11} \parallel 9$ | | $\Omega \parallel \text{pF}$ |
| Common mode voltage range ⁽²⁾ | $V_O = 0\text{ V}$ | (V+) – 2 | (V+) – 1.4 | | (V+) – 2 | (V+) – 1.4 | | V |
| | | (V-) + 2 | (V-) + 1.7 | | (V-) + 2 | (V-) + 1.7 | | V |
| Safe input voltage | | | | ± 40 | | | ± 40 | V |
| Common-mode rejection | $V_{\text{CM}} = \pm 13\text{ V}$, $\Delta R_S = 1\text{ k}\Omega$ | | | | | | | dB |
| | G = 1 | 58 | 86 | | 58 | 75 | | |
| | G = 10 | 78 | 106 | | 78 | 85 | | |
| | G = 100 | 99 | 125 | | 99 | 110 | | |
| | | G = 1000 | 113 | 130 | | 113 | 120 | |
| CURRENT | | | | | | | | |
| Bias current | | | ± 2 | ± 10 | | | ± 45 | nA |
| vs temperature | | | ± 30 | | | ± 550 | | $\text{pA}/^\circ\text{C}$ |
| Offset Current | | | ± 1 | ± 10 | | | ± 45 | nA |
| vs temperature | | | ± 30 | | | ± 550 | | $\text{pA}/^\circ\text{C}$ |
| NOISE | | | | | | | | |
| Noise voltage, RTI | G = 1000, $R_S = 0\ \Omega$ | | | | | | | |
| f = 10 Hz | | | 10 | | | 10 | | $\text{nV}/\sqrt{\text{Hz}}$ |
| f = 100 Hz | | | 8 | | | 8 | | $\text{nV}/\sqrt{\text{Hz}}$ |
| f = 1 kHz | | | 8 | | | 8 | | $\text{nV}/\sqrt{\text{Hz}}$ |
| $f_B = 0.1\text{ Hz to } 10\text{ Hz}$ | | | 0.2 | | | 0.8 | | μV_{PP} |
| Noise current | | | | | | | | |
| f = 10 Hz | | | 0.9 | | | | | $\text{pA}/\sqrt{\text{Hz}}$ |
| f = 1 kHz | | | 0.3 | | | | | $\text{pA}/\sqrt{\text{Hz}}$ |
| $f_B = 0.1\text{ Hz to } 10\text{ Hz}$ | | | 30 | | | | | pA_{PP} |

- (1) Minimum and maximum parameters are characterized for operation at $T_A = 175^\circ\text{C}$, but may not be production tested at that temperature. Production test limits with statistical guardbands are used to ensure high temperature performance.
- (2) Input common-mode range varies with output voltage — see typical curves.

ELECTRICAL CHARACTERISTICS FOR INA128 (continued)

T_A = 25°C, V_S = ±15 V, R_L = 10 kΩ (unless otherwise noted)

| PARAMETER | TEST CONDITIONS | T _A = -55°C to 125°C | | | T _A = 175°C ⁽¹⁾ | | | UNIT | |
|------------------------------------|------------------------------------|---------------------------------|------------|--------------------|---------------------------------------|------------|--------------------|----------|----|
| | | MIN | TYP | MAX | MIN | TYP | MAX | | |
| GAIN | | | | | | | | | |
| Gain equation | | 1 + (50 kΩ/R _G) | | | 1 + (50 kΩ/R _G) | | | V/V | |
| Range of gain | | 1 | | 10000 | 1 | | 10000 | V/V | |
| Gain error | G = 1 | | ±0.01 | ±0.1 | | ±0.1 | ±0.5 | % | |
| | G = 10 | | ±0.02 | ±0.5 | | ±0.5 | ±1 | | |
| | G = 100 | | ±0.05 | ±0.7 | | ±0.7 | ±1.5 | | |
| | G = 1000 | | ±0.5 | ±2.5 | | ±2 | ±4 | | |
| Gain vs temperature ⁽³⁾ | G = 1 | | ±1 | ±10 | | ±75 | | ppm/°C | |
| 50-kΩ resistance ⁽³⁾⁽⁴⁾ | | | ±25 | ±100 | | ±75 | | ppm/°C | |
| Nonlinearity | V _O = ±13.6 V, G = 1 | | ±0.0001 | ±0.001 | | | ±0.008 | % of FSR | |
| | G = 10 | | ±0.0003 | ±0.002 | | | ±0.010 | | |
| | G = 100 | | ±0.0005 | ±0.002 | | | ±0.010 | | |
| | G = 1000 | | ±0.001 | See ⁽⁵⁾ | | ±0.6 | See ⁽⁵⁾ | | |
| OUTPUT | | | | | | | | | |
| Voltage | Positive | R _L = 10kΩ | (V+) - 1.4 | (V+) - 0.9 | (V+) - 1.4 | (V+) - 0.9 | | V | |
| | Negative | R _L = 10kΩ | (V-) + 1.4 | (V-) + 0.8 | (V-) + 1.4 | (V-) + 0.8 | | | |
| Load capacitance stability | | | | 1000 | | 1000 | | pF | |
| Short-circuit current | | | | +6/-15 | | +6/-15 | | mA | |
| FREQUENCY RESPONSE | | | | | | | | | |
| Bandwidth, -3 dB | G = 1 | | | 1300 | | | 1100 | kHz | |
| | G = 10 | | | 700 | | | 700 | | |
| | G = 100 | | | 200 | | | 190 | | |
| | G = 1000 | | | 20 | | | 17.5 | | |
| Slew rate | V _O = ±10 V, G = 10 | | | 4 | | | 4 | V/μs | |
| Settling time, 0.01% | G = 1 | | | 7 | | | 7 | μs | |
| | G = 10 | | | 7 | | | 7 | | |
| | G = 100 | | | 9 | | | 9 | | |
| | G = 1000 | | | 80 | | | 80 | | |
| Overload recovery | 50% overdrive | | | 4 | | | 4 | μs | |
| POWER SUPPLY | | | | | | | | | |
| Voltage range | | | ±2.25 | ±15 | ±18 | ±2.25 | ±15 | ±18 | V |
| Current, total | V _{IN} = 0 V | | | ±0.7 | ±1 | | | ±1 | mA |
| TEMPERATURE RANGE | | | | | | | | | |
| Specification | | | -55 | | 125 | | | 175 | °C |
| Operating | | | -55 | | 125 | | | 175 | °C |

(3) Specified by wafer test.

(4) Temperature coefficient of the 50-kΩ term in the gain equation.

(5) Nonlinearity measurements in G = 1000 are dominated by noise. Typical nonlinearity is ±0.001%.

ELECTRICAL CHARACTERISTICS FOR INA129

over operating free-air temperature range (unless otherwise noted)

| PARAMETER | TEST CONDITIONS | $T_A = -55^{\circ}\text{C to } 125^{\circ}\text{C}$ | | | $T_A = 210^{\circ}\text{C}^{(1)}$ | | | UNIT |
|--|---|---|--------------------------------|----------------------------------|-----------------------------------|---------------------------------|----------|--------------------------------|
| | | MIN | TYP | MAX | MIN | TYP | MAX | |
| INPUT | | | | | | | | |
| OFFSET VOLTAGE, RTI | | | | | | | | |
| Initial | $T_A = 25^{\circ}\text{C}$ | | ± 25 $\pm 100/\text{G}$ | ± 125 $\pm 1000/\text{G}$ | | | | μV |
| vs temperature | $T_A = T_{\text{MIN}} \text{ to } T_{\text{MAX}}$ | | ± 0.2 $\pm 5/\text{G}$ | ± 1 $\pm 20/\text{G}$ | | ± 1 $\pm 850/\text{G}$ | | $\mu\text{V}/^{\circ}\text{C}$ |
| vs power supply | $V_S = \pm 2.25 \text{ V to } \pm 18 \text{ V}$ | | ± 0.2 $\pm 20/\text{G}$ | ± 2 $\pm 200/\text{G}$ | | ± 20 $\pm 1000/\text{G}$ | | $\mu\text{V}/\text{V}$ |
| Long-term stability | | | ± 1 $\pm 3/\text{G}$ | | | ± 1 $\pm 3/\text{G}$ | | $\mu\text{V}/\text{mo}$ |
| Impedance, differential | | | $10^{10} \parallel 2$ | | | $10^{10} \parallel 2$ | | $\Omega \parallel \text{pF}$ |
| Common mode | | | $10^{11} \parallel 9$ | | | $10^{11} \parallel 9$ | | $\Omega \parallel \text{pF}$ |
| Common mode voltage range ⁽²⁾ | $V_O = 0 \text{ V}$ | $(V+) - 2$ | $(V+) - 1.4$ | | $(V+) - 2$ | $(V+) - 1.4$ | | V |
| | | $(V-) + 2$ | $(V-) + 1.7$ | | $(V-) + 2$ | $(V-) + 1.7$ | | V |
| Safe input voltage | | | | ± 40 | | | ± 40 | V |
| Common-mode rejection | $V_{\text{CM}} = \pm 13 \text{ V},$ $\Delta R_S = 1 \text{ k}\Omega$ | | | | | | | dB |
| | $G = 1$ | 58 | 86 | | 53 | | | |
| | $G = 10$ | 78 | 106 | | 69 | | | |
| | $G = 100$ | 99 | 125 | | 89 | | | |
| | $G = 1000$ | 113 | 130 | | 95 | | | |
| CURRENT | | | | | | | | |
| Bias current | | | ± 2 | ± 10 | | ± 50 | | nA |
| vs temperature | | | ± 30 | | | ± 600 | | $\text{pA}/^{\circ}\text{C}$ |
| Offset Current | | | ± 1 | ± 10 | | ± 50 | | nA |
| vs temperature | | | ± 30 | | | ± 600 | | $\text{pA}/^{\circ}\text{C}$ |
| NOISE | | | | | | | | |
| Noise voltage, RTI | $G = 1000,$ $R_S = 0 \Omega$ | | | | | | | |
| $f = 10 \text{ Hz}$ | | | 10 | | 25 | | | $\text{nV}/\sqrt{\text{Hz}}$ |
| $f = 100 \text{ Hz}$ | | | 8 | | 20 | | | $\text{nV}/\sqrt{\text{Hz}}$ |
| $f = 1 \text{ kHz}$ | | | 8 | | 20 | | | $\text{nV}/\sqrt{\text{Hz}}$ |
| $f_B = 0.1 \text{ Hz to } 10 \text{ Hz}$ | | | 0.2 | | 2 | | | μV_{PP} |
| Noise current | | | | | | | | |
| $f = 10 \text{ Hz}$ | | | 0.9 | | | | | $\text{pA}/\sqrt{\text{Hz}}$ |
| $f = 1 \text{ kHz}$ | | | 0.3 | | | | | $\text{pA}/\sqrt{\text{Hz}}$ |
| $f_B = 0.1 \text{ Hz to } 10 \text{ Hz}$ | | | 30 | | | | | pA_{PP} |

(1) Minimum and maximum parameters are characterized for operation at $T_A = 210^{\circ}\text{C}$, but may not be production tested at that temperature. Production test limits with statistical guardbands are used to ensure high temperature performance.

(2) Input common-mode range varies with output voltage — see typical curves.

ELECTRICAL CHARACTERISTICS FOR INA129 (continued)

over operating free-air temperature range (unless otherwise noted)

| PARAMETER | TEST CONDITIONS | T _A = -55°C to 125°C | | | T _A = 210°C ⁽¹⁾ | | | UNIT |
|--------------------------------------|------------------------------------|----------------------------------|------------|--------------------|---------------------------------------|------------|--------------------|----------|
| | | MIN | TYP | MAX | MIN | TYP | MAX | |
| GAIN | | | | | | | | |
| Gain equation | | $1 + (49.4 \text{ k}\Omega/R_G)$ | | | $1 + (49.4 \text{ k}\Omega/R_G)$ | | | V/V |
| Range of gain | | 1 | | 10000 | 1 | | 10000 | V/V |
| Gain error | G = 1 | | ±0.01 | ±0.1 | | ±1.1 | | % |
| | G = 10 | | ±0.02 | ±0.5 | | ±2.6 | | |
| | G = 100 | | ±0.05 | ±0.7 | | ±13.5 | | |
| | G = 1000 | | ±0.5 | ±2.5 | | ±65.5 | | |
| Gain vs temperature ⁽³⁾ | G = 1 | | ±1 | ±10 | | ±100 | | ppm/°C |
| 49.4-kΩ resistance ⁽³⁾⁽⁴⁾ | | | ±25 | ±100 | | ±100 | | ppm/°C |
| Nonlinearity | V _O = ±13.6 V, G = 1 | | ±0.0001 | ±0.001 | | ±0.1 | | % of FSR |
| | G = 10 | | ±0.0003 | ±0.002 | | ±0.2 | | |
| | G = 100 | | ±0.0005 | ±0.002 | | ±0.7 | | |
| | G = 1000 | | ±0.001 | See ⁽⁵⁾ | | ±2.4 | See ⁽⁵⁾ | |
| OUTPUT | | | | | | | | |
| Voltage | Positive | R _L = 10kΩ | (V+) - 1.4 | (V+) - 0.9 | (V+) - 1.4 | (V+) - 0.9 | | V |
| | Negative | R _L = 10kΩ | (V-) + 1.4 | (V-) + 0.8 | (V-) + 1.4 | (V-) + 0.8 | | |
| Load capacitance stability | | | 1000 | | 1000 | | | pF |
| Short-circuit current | | | +6/-15 | | +12/-5 | | | mA |
| FREQUENCY RESPONSE | | | | | | | | |
| Bandwidth, -3 dB | G = 1 | | 1300 | | 850 | | | kHz |
| | G = 10 | | 700 | | 400 | | | |
| | G = 100 | | 200 | | 50 | | | |
| | G = 1000 | | 20 | | 7.5 | | | |
| Slew rate | V _O = ±10 V, G = 10 | | 4 | | 4 | | | V/μs |
| Settling time, 0.01% | G = 1 | | 7 | | 10 | | | μs |
| | G = 10 | | 7 | | 10 | | | |
| | G = 100 | | 9 | | 30 | | | |
| | G = 1000 | | 80 | | 150 | | | |
| Overload recovery | 50% overdrive | | 4 | | 4 | | | μs |
| POWER SUPPLY | | | | | | | | |
| Voltage range | | ±2.25 | ±15 | ±18 | ±2.25 | ±15 | ±18 | V |
| Current, total | V _{IN} = 0 V | | ±0.7 | ±1 | | ±2 | | mA |
| TEMPERATURE RANGE | | | | | | | | |
| Specification | | -55 | | 125 | | 210 | | °C |
| Operating | | -55 | | 125 | | 210 | | °C |

(3) Specified by wafer test.

(4) Temperature coefficient of the 49.4-kΩ term in the gain equation.

(5) Nonlinearity measurements in G = 1000 are dominated by noise. Typical nonlinearity is ±0.001%.

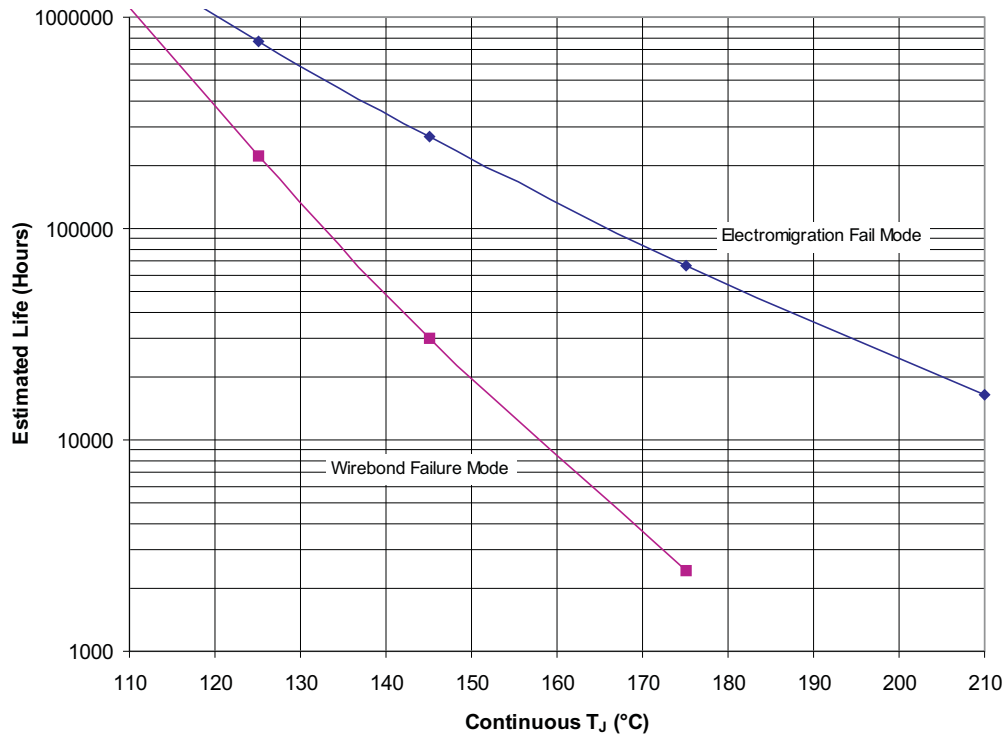

- (1) See the data sheet for absolute maximum and minimum recommended operating conditions.
- (2) The predicted operating lifetime vs. junction temperature is based on reliability modeling using electromigration as the dominant failure mechanism affecting device wearout for the specific device process and design characteristics.
- (3) Wirebond lifetime is only applicable for D package.

Figure 1. INA128HD/INA129SKGD1 Operating Life Derating Chart

TYPICAL CHARACTERISTICS

At $T_A = 25^\circ\text{C}$, $V_S = \pm 15\text{ V}$, unless otherwise noted.

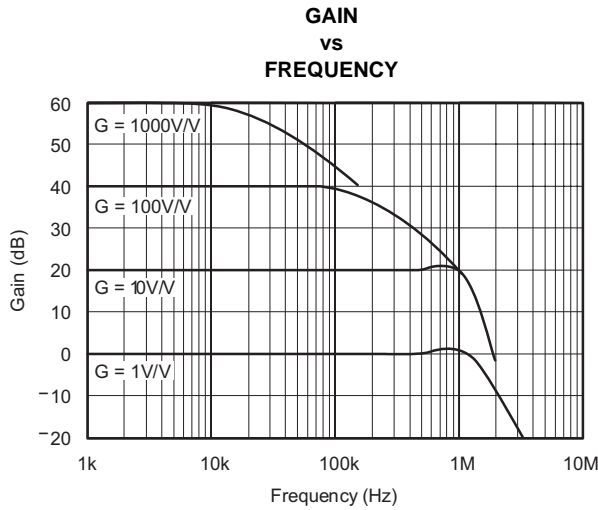

Figure 2.

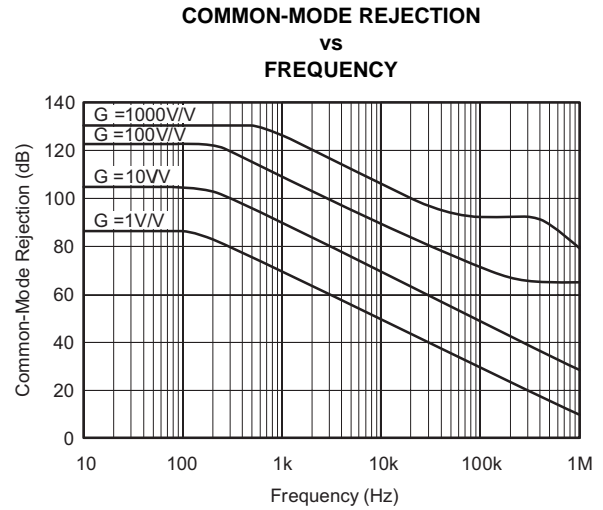

Figure 3.

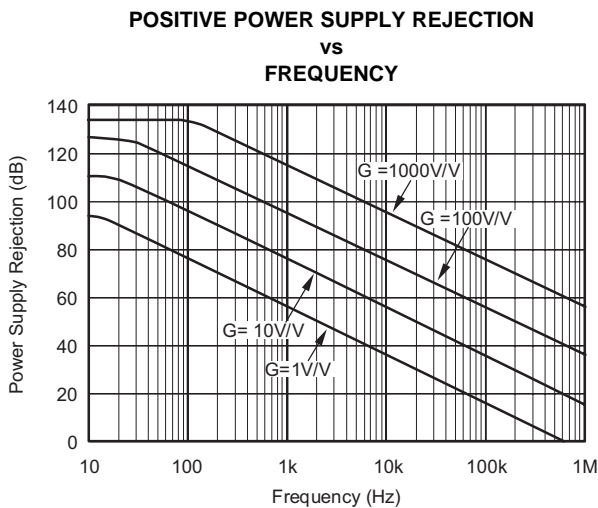

Figure 4.

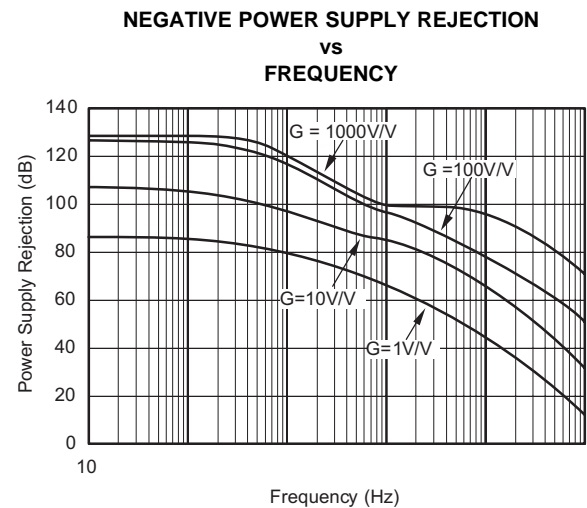

Figure 5.

TYPICAL CHARACTERISTICS (continued)

At $T_A = 25^\circ\text{C}$, $V_S = \pm 15\text{ V}$, unless otherwise noted.

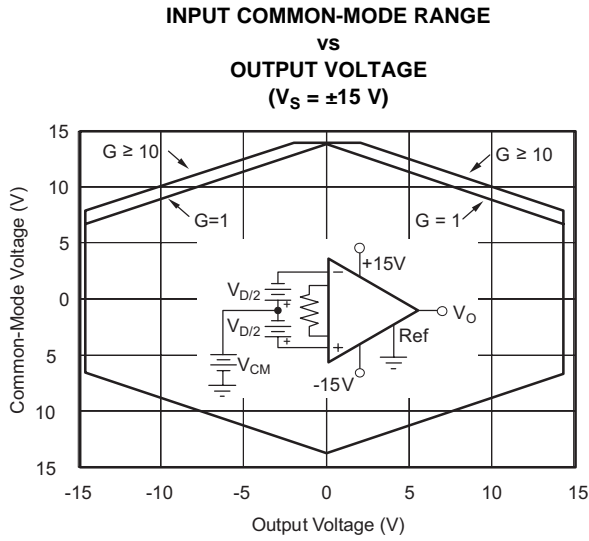

Figure 6.

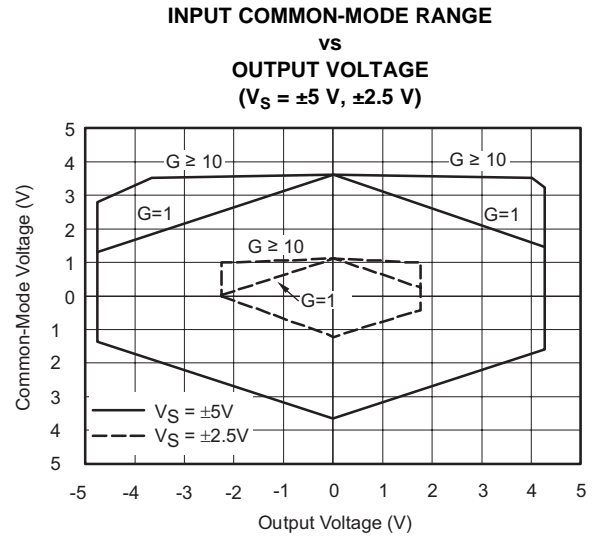

Figure 7.

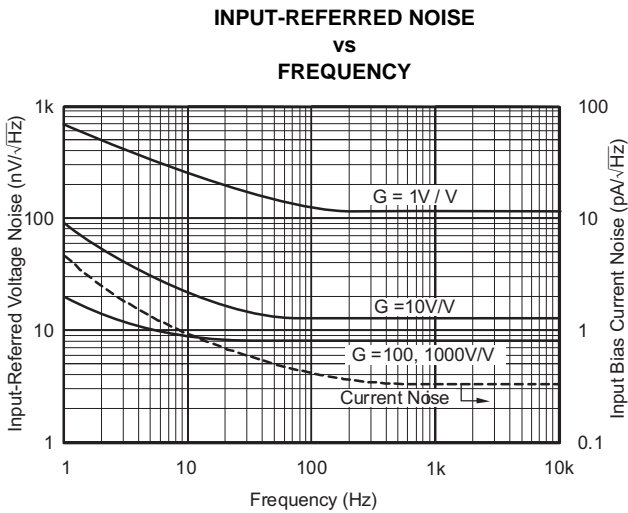

Figure 8.

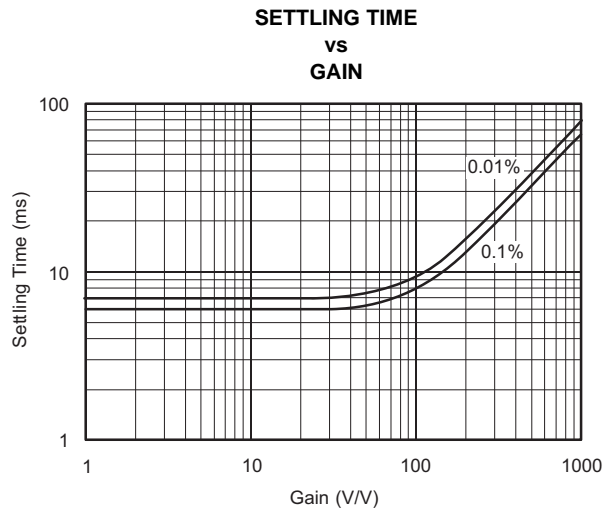

Figure 9.

TYPICAL CHARACTERISTICS (continued)

At $T_A = 25^\circ\text{C}$, $V_S = \pm 15\text{ V}$, unless otherwise noted.

**QUIESCENT CURRENT AND SLEW RATE
vs
TEMPERATURE**

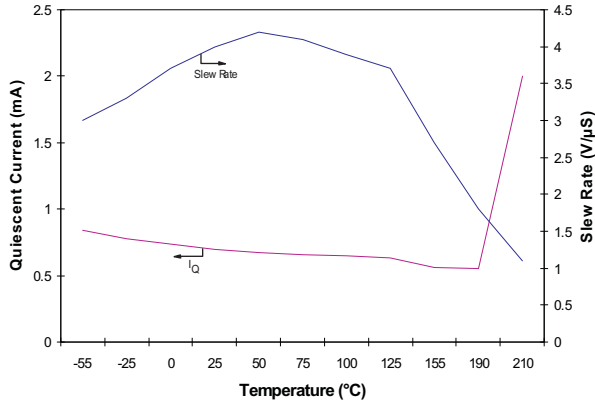

Figure 10.

INPUT OVER-VOLTAGE VI CHARACTERISTICS

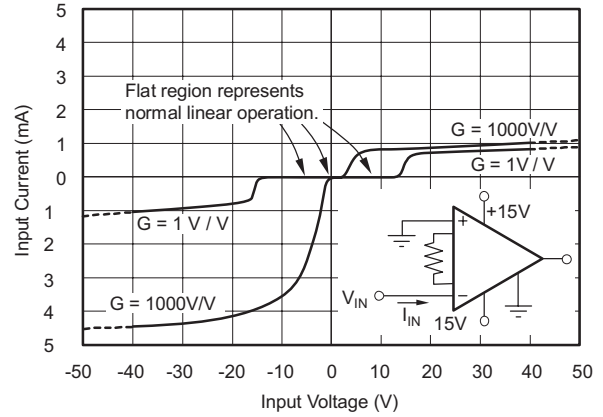

Figure 11.

INPUT OFFSET VOLTAGE WARM-UP

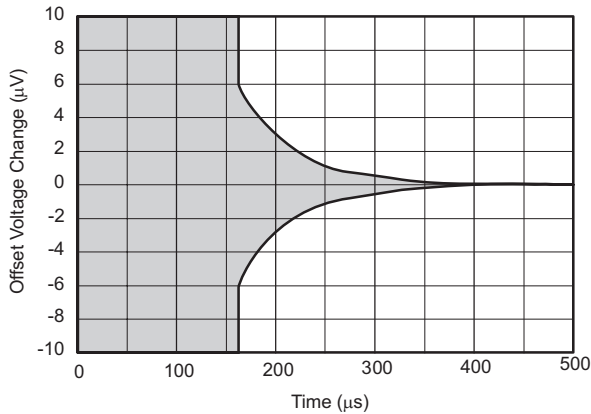

Figure 12.

**INPUT BIAS CURRENT
vs
TEMPERATURE**

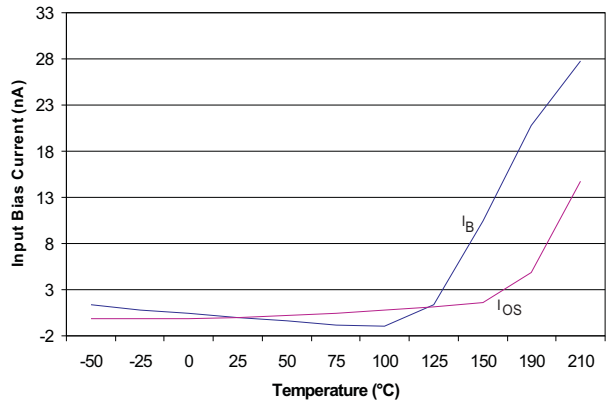

Figure 13.

TYPICAL CHARACTERISTICS (continued)

At $T_A = 25^\circ\text{C}$, $V_S = \pm 15\text{ V}$, unless otherwise noted.

**OUTPUT VOLTAGE SWING
vs
OUTPUT CURRENT**

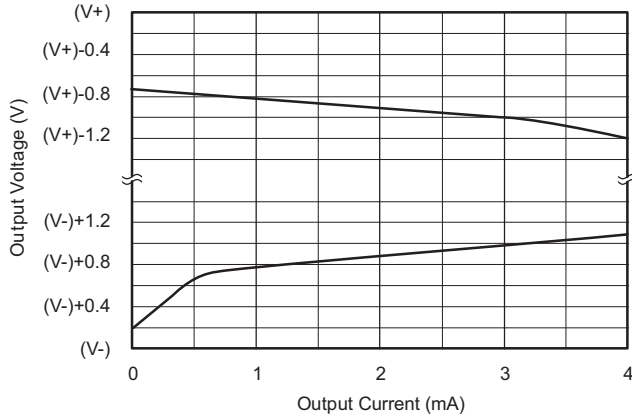

Figure 14.

**OUTPUT VOLTAGE SWING
vs
POWER SUPPLY VOLTAGE**

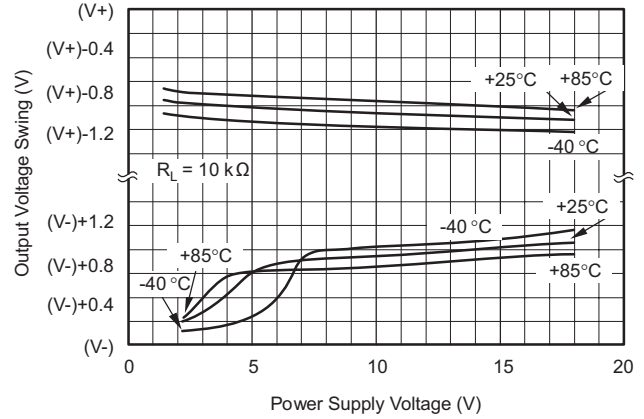

Figure 15.

**SHORT-CIRCUIT OUTPUT CURRENT
vs
TEMPERATURE**

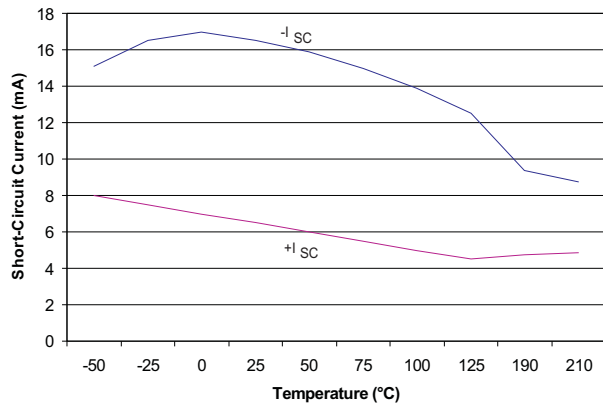

Figure 16.

**MAXIMUM OUTPUT VOLTAGE
vs
FREQUENCY**

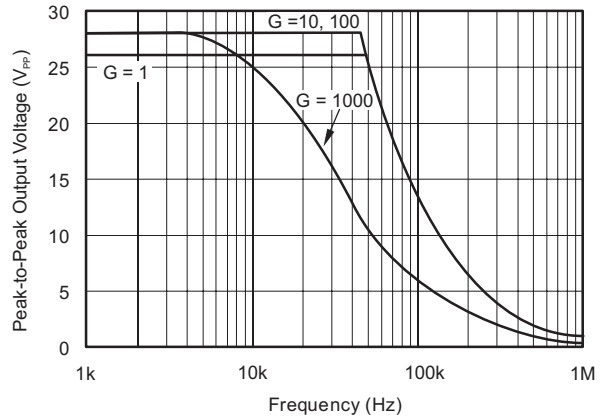

Figure 17.

TYPICAL CHARACTERISTICS (continued)

At $T_A = 25^\circ\text{C}$, $V_S = \pm 15\text{ V}$, unless otherwise noted.

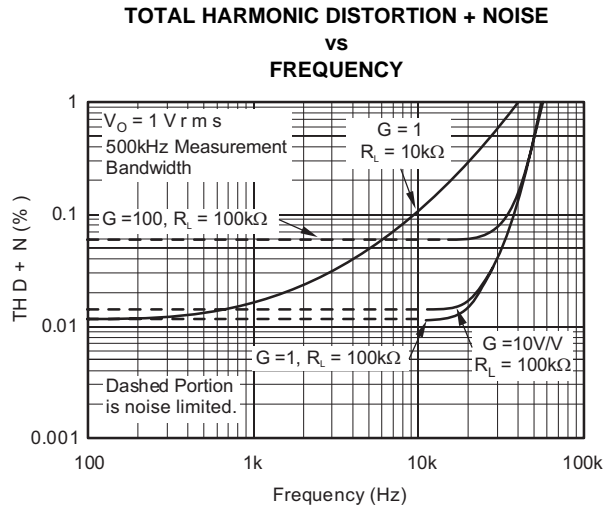

Figure 18.

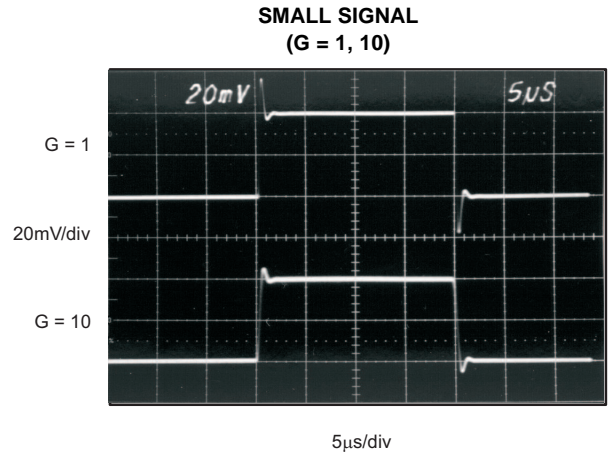

Figure 19.

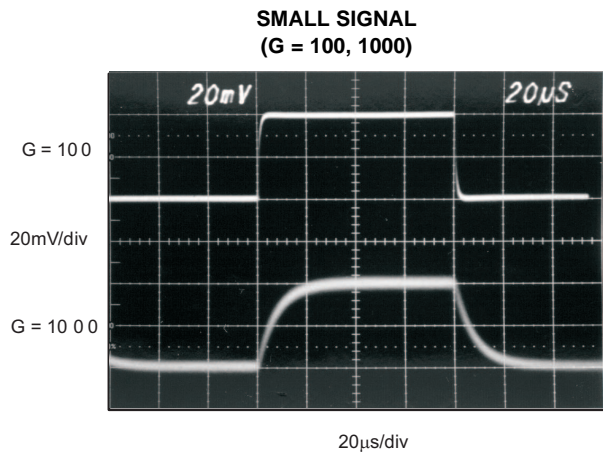

Figure 20.

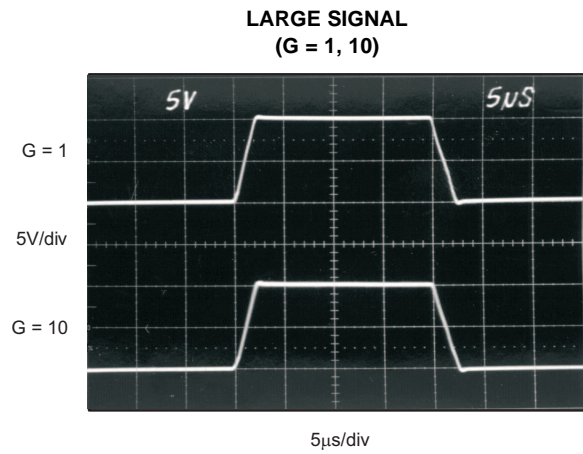

Figure 21.

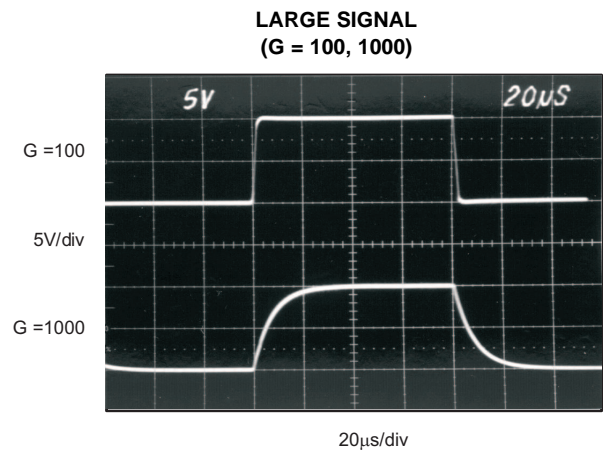

Figure 22.

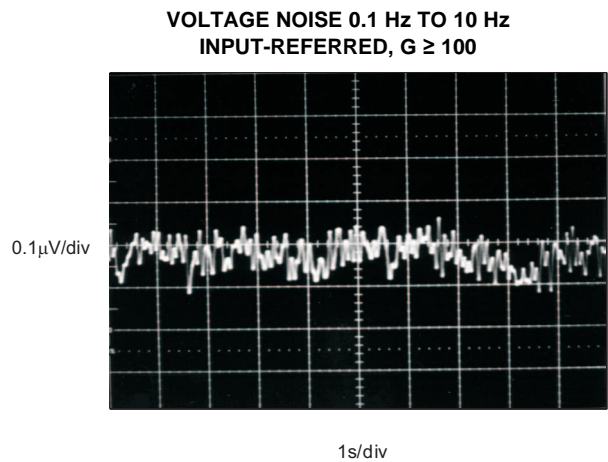

Figure 23.

APPLICATION INFORMATION

Figure 24 shows the basic connections required for operation of the INA128/INA129. Applications with noisy or high impedance power supplies may require decoupling capacitors close to the device pins as shown.

The output is referred to the output reference (Ref) terminal which is normally grounded. This must be a low-impedance connection to assure good common-mode rejection. A resistance of 8 Ω in series with the Ref pin will cause a typical device to degrade.

Setting the Gain

Gain is set by connecting a single external resistor, R_G , between pins 1 and 8.

INA128:

$$G = 1 + \frac{50 \text{ k}\Omega}{R_G} \quad (1)$$

INA129:

$$G = 1 + \frac{49.4 \text{ k}\Omega}{R_G} \quad (2)$$

Commonly used gains and resistor values are shown in Figure 24.

The 50-kΩ term in Equation 1 (49.4-kΩ in Equation 2) comes from the sum of the two internal feedback resistors of A1 and A2. These on-chip metal film resistors are laser trimmed to accurate absolute values. The accuracy and temperature coefficient of these internal resistors are included in the gain accuracy and drift specifications of the INA128/INA129.

The stability and temperature drift of the external gain setting resistor, R_G , also affects gain. R_G 's contribution to gain accuracy and drift can be directly inferred from Equation 2. Low resistor values required for high gain can make wiring resistance important. Sockets add to the wiring resistance which will contribute additional gain error (possibly an unstable gain error) in gains of approximately 100 or greater.

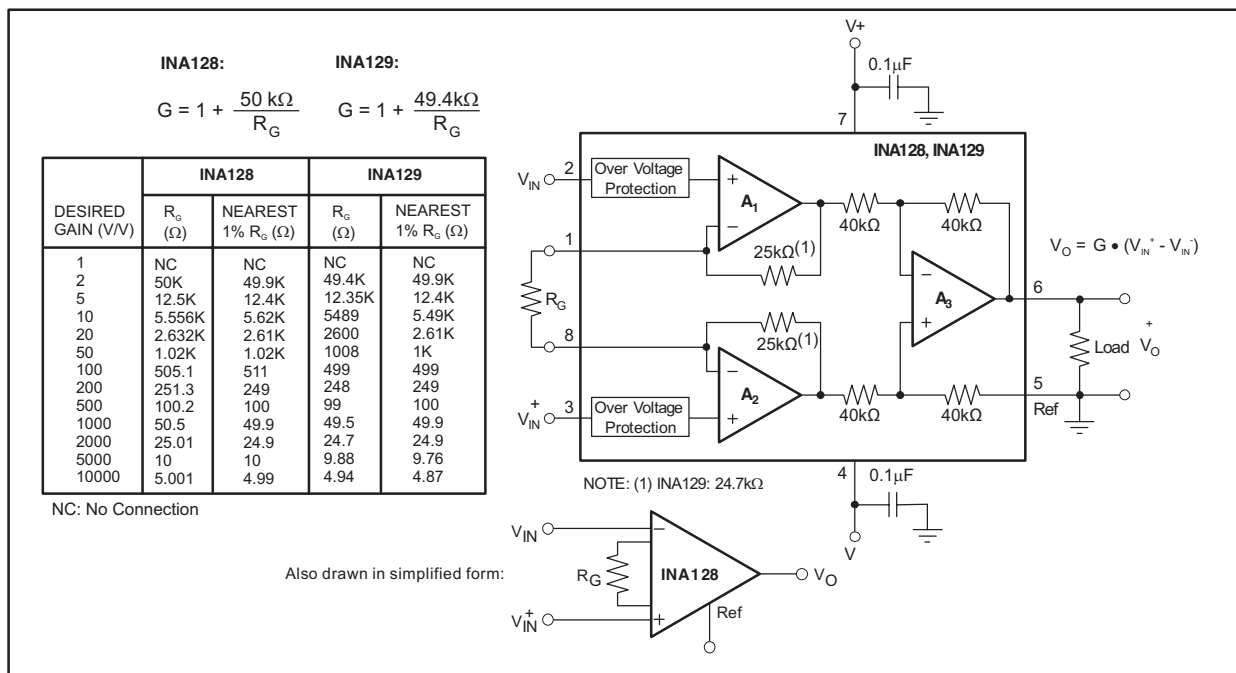

Figure 24. Basic Connections

Dynamic Performance

Figure 2 shows that, despite its low quiescent current, the INA128/INA129 achieves wide bandwidth, even at high gain. This is due to the current-feedback topology of the input stage circuitry. Settling time also remains excellent at high gain.

Noise Performance

The INA128/INA129 provides very low noise in most applications. Low frequency noise is approximately 2 μ VPP measured from 0.1 Hz to 10 Hz ($G \geq 100$). This provides dramatically improved noise when compared to state-of-the-art chopper-stabilized amplifiers.

Offset Trimming

The INA128/INA129 is laser trimmed for low offset voltage and offset voltage drift. Most applications require no external offset adjustment. Figure 25 shows an optional circuit for trimming the output offset voltage. The voltage applied to Ref terminal is summed with the output. The operational amplifier buffer provides low impedance at the Ref terminal to preserve good common-mode rejection.

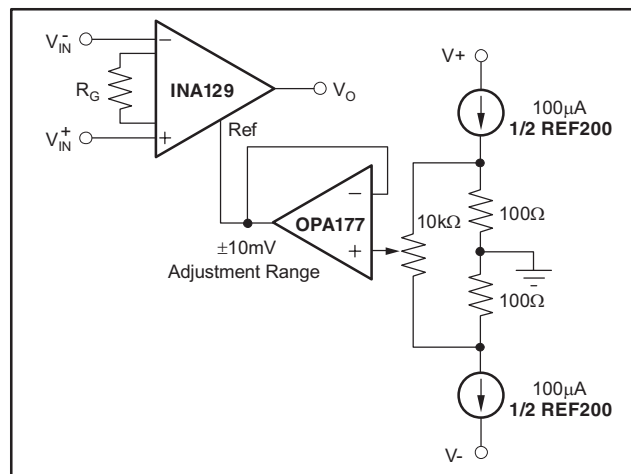

(1) OPA177 and REF200 are not tested or characterized at 210°C.

Figure 25. Optional Trimming of Output Offset Voltage

Input Bias Current Return Path

The input impedance of the INA128/INA129 is extremely high (approximately $10^{10} \Omega$). However, a path must be provided for the input bias current of both inputs. This input bias current is approximately ± 50 nA. High input impedance means that this input bias current changes very little with varying input voltage.

Input circuitry must provide a path for this input bias current for proper operation. Figure 26 shows various provisions for an input bias current path. Without a bias current path, the inputs will float to a potential which exceeds the common-mode range, and the input amplifiers will saturate.

If the differential source resistance is low, the bias current return path can be connected to one input (see the thermocouple example in Figure 26). With higher source impedance, using two equal resistors provides a balanced input with possible advantages of lower input offset voltage due to bias current and better high-frequency common-mode rejection.

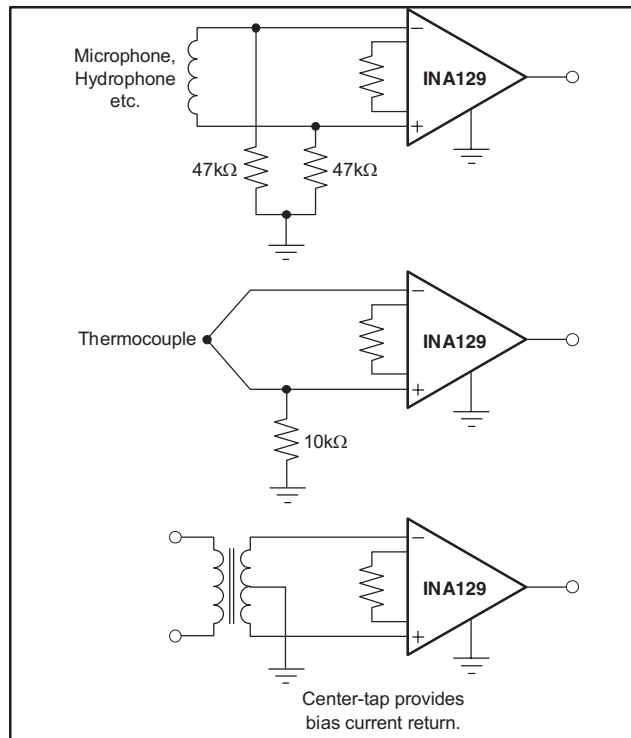

Figure 26. Providing an Input Common-Mode Current Path

Input Common-Mode Range

The linear input voltage range of the input circuitry of the INA128/INA129 is from approximately 1.4 V below the positive supply voltage to 1.7 V above the negative supply. As a differential input voltage causes the output voltage increase, however, the linear input range will be limited by the output voltage swing of amplifiers A1 and A2. So the linear common-mode input range is related to the output voltage of the complete amplifier. This behavior also depends on supply voltage (see [Figure 6](#) and [Figure 7](#)).

Input-overload can produce an output voltage that appears normal. For example, if an input overload condition drives both input amplifiers to their positive output swing limit, the difference voltage measured by the output amplifier will be near zero. The output of A3 will be near 0 V even though both inputs are overloaded.

Low Voltage Operation

The INA128/INA129 can be operated on power supplies as low as ± 2.25 V. Performance remains excellent with power supplies ranging from ± 2.25 V to ± 18 V. Most parameters vary only slightly throughout this supply voltage range.

Operation at very low supply voltage requires careful attention to assure that the input voltages remain within their linear range. Voltage swing requirements of internal nodes limit the input common-mode range with low power supply voltage. [Figure 6](#) and [Figure 7](#) show the range of linear operation for ± 15 V, ± 5 V, and ± 2.5 V supplies.

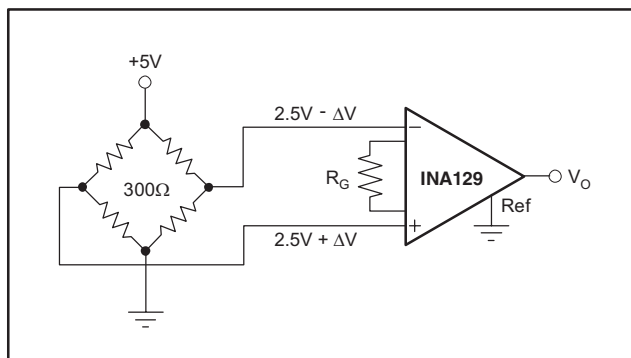
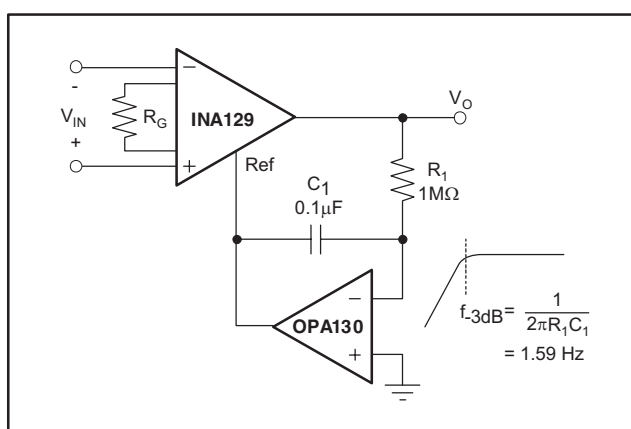
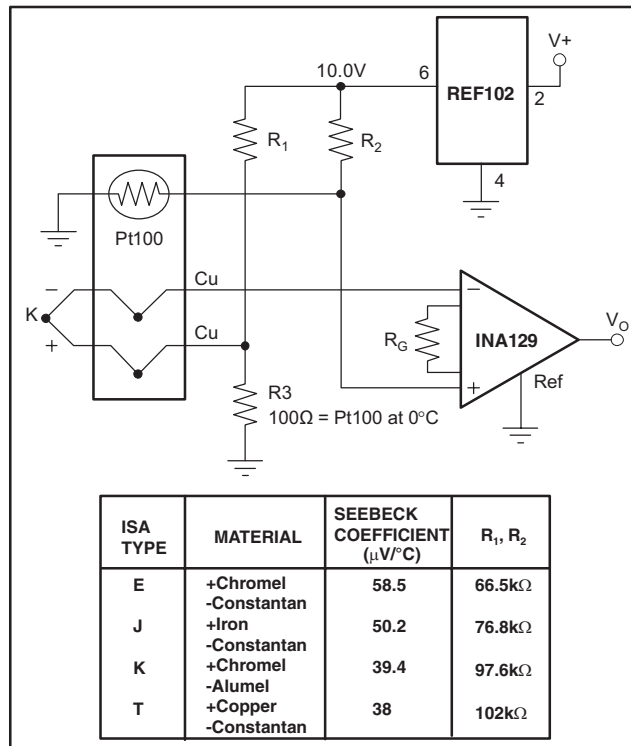

Figure 27. Bridge Amplifier



(1) OPA130 is not tested or characterized at 210°C.

Figure 28. AC-Coupled Instrumentation Amplifier



(1) REF102 is not tested or characterized at 210°C.

Figure 29. Thermocouple Amplifier With RTD Cold-Junction Compensation

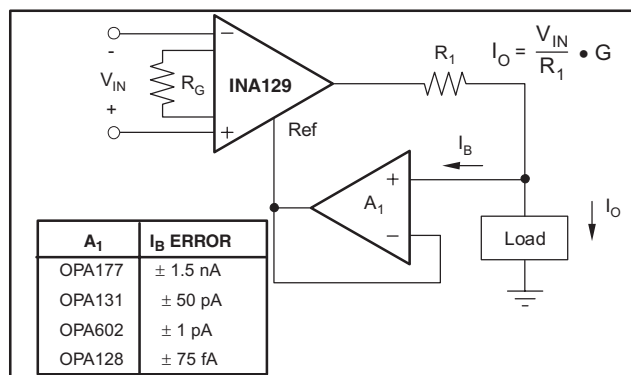

(1) OPA177, OPA131, OPA602 and OPA128 are not tested or characterized at 210°C.

Figure 30. Differential Voltage to Current Converter

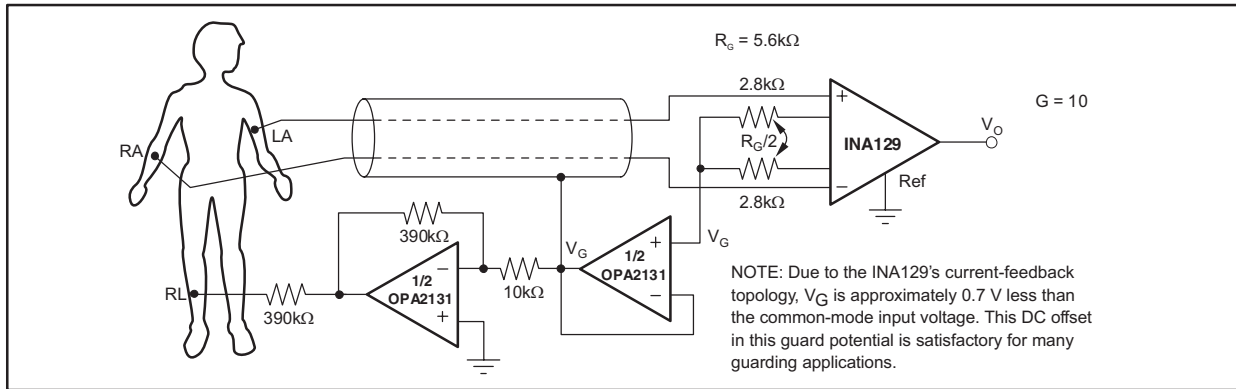

(1) OPA2131 is not tested or characterized at 210°C.

Figure 31. ECG Amplifier With Right-Leg Drive

PACKAGING INFORMATION

| Orderable Device | Status ⁽¹⁾ | Package Type | Package Drawing | Pins | Package Qty | Eco Plan ⁽²⁾ | Lead/ Ball Finish | MSL Peak Temp ⁽³⁾ | Samples (Requires Login) |
|------------------|-----------------------|--------------|-----------------|------|-------------|----------------------------|----------------------|------------------------------|-----------------------------|
| INA128HD | ACTIVE | SOIC | D | 8 | 50 | Green (RoHS & no Sb/Br) | CU NIPDAU | Level-3-260C-168 HR | |
| INA129SHKJ | ACTIVE | CFP | HKJ | 8 | 1 | TBD | Call TI | N / A for Pkg Type | |
| INA129SHKQ | ACTIVE | CFP | HKQ | 8 | 1 | TBD | AU | N / A for Pkg Type | |
| INA129SJD | ACTIVE | CDIP SB | JDJ | 8 | 1 | TBD | POST-PLATE | N / A for Pkg Type | |
| INA129SKGD1 | ACTIVE | XCEPT | KGD | 0 | 180 | TBD | Call TI | N / A for Pkg Type | |

⁽¹⁾ The marketing status values are defined as follows:

ACTIVE: Product device recommended for new designs.

LIFEBUY: TI has announced that the device will be discontinued, and a lifetime-buy period is in effect.

NRND: Not recommended for new designs. Device is in production to support existing customers, but TI does not recommend using this part in a new design.

PREVIEW: Device has been announced but is not in production. Samples may or may not be available.

OBSOLETE: TI has discontinued the production of the device.

⁽²⁾ Eco Plan - The planned eco-friendly classification: Pb-Free (RoHS), Pb-Free (RoHS Exempt), or Green (RoHS & no Sb/Br) - please check <http://www.ti.com/productcontent> for the latest availability information and additional product content details.

TBD: The Pb-Free/Green conversion plan has not been defined.

Pb-Free (RoHS): TI's terms "Lead-Free" or "Pb-Free" mean semiconductor products that are compatible with the current RoHS requirements for all 6 substances, including the requirement that lead not exceed 0.1% by weight in homogeneous materials. Where designed to be soldered at high temperatures, TI Pb-Free products are suitable for use in specified lead-free processes.

Pb-Free (RoHS Exempt): This component has a RoHS exemption for either 1) lead-based flip-chip solder bumps used between the die and package, or 2) lead-based die adhesive used between the die and leadframe. The component is otherwise considered Pb-Free (RoHS compatible) as defined above.

Green (RoHS & no Sb/Br): TI defines "Green" to mean Pb-Free (RoHS compatible), and free of Bromine (Br) and Antimony (Sb) based flame retardants (Br or Sb do not exceed 0.1% by weight in homogeneous material)

⁽³⁾ MSL, Peak Temp. -- The Moisture Sensitivity Level rating according to the JEDEC industry standard classifications, and peak solder temperature.

Important Information and Disclaimer: The information provided on this page represents TI's knowledge and belief as of the date that it is provided. TI bases its knowledge and belief on information provided by third parties, and makes no representation or warranty as to the accuracy of such information. Efforts are underway to better integrate information from third parties. TI has taken and continues to take reasonable steps to provide representative and accurate information but may not have conducted destructive testing or chemical analysis on incoming materials and chemicals. TI and TI suppliers consider certain information to be proprietary, and thus CAS numbers and other limited information may not be available for release.

In no event shall TI's liability arising out of such information exceed the total purchase price of the TI part(s) at issue in this document sold by TI to Customer on an annual basis.

OTHER QUALIFIED VERSIONS OF INA128-HT, INA129-HT :

- Catalog: [INA128](#), [INA129](#)
- Enhanced Product: [INA129-EP](#)

NOTE: Qualified Version Definitions:

- Catalog - TI's standard catalog product
- Enhanced Product - Supports Defense, Aerospace and Medical Applications

MECHANICAL DATA

HKJ (R-CDFP-F8)

CERAMIC DUAL FLATPACK

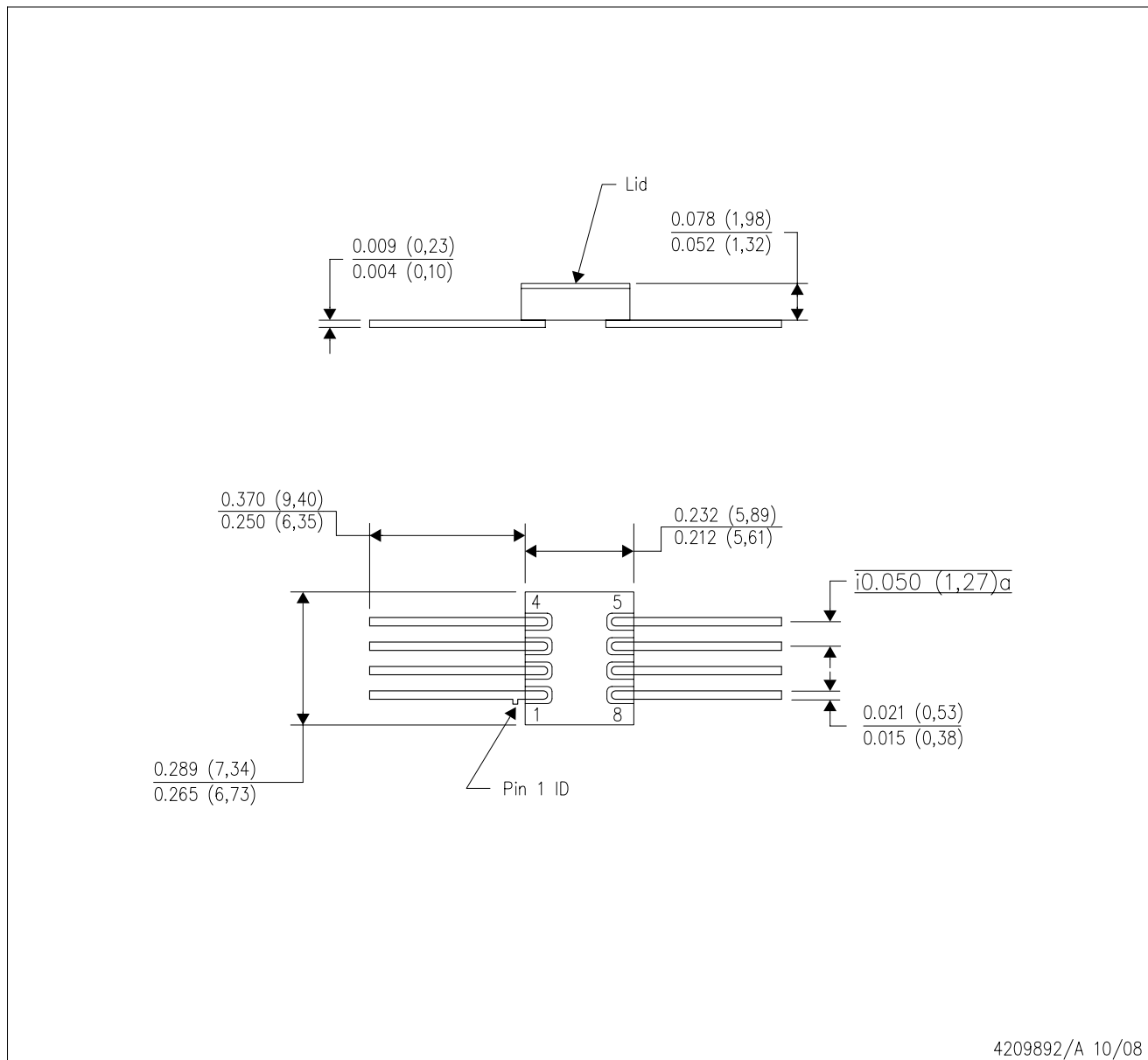

4209892/A 10/08

- NOTES:
- A. All linear dimensions are in inches (millimeters).
 - B. This drawing is subject to change without notice.
 - C. This package can be hermetically sealed with a metal lid.
 - D. The terminals will be gold plated.

MECHANICAL DATA

HKQ (R-CDFP-G8)

CERAMIC GULL WING

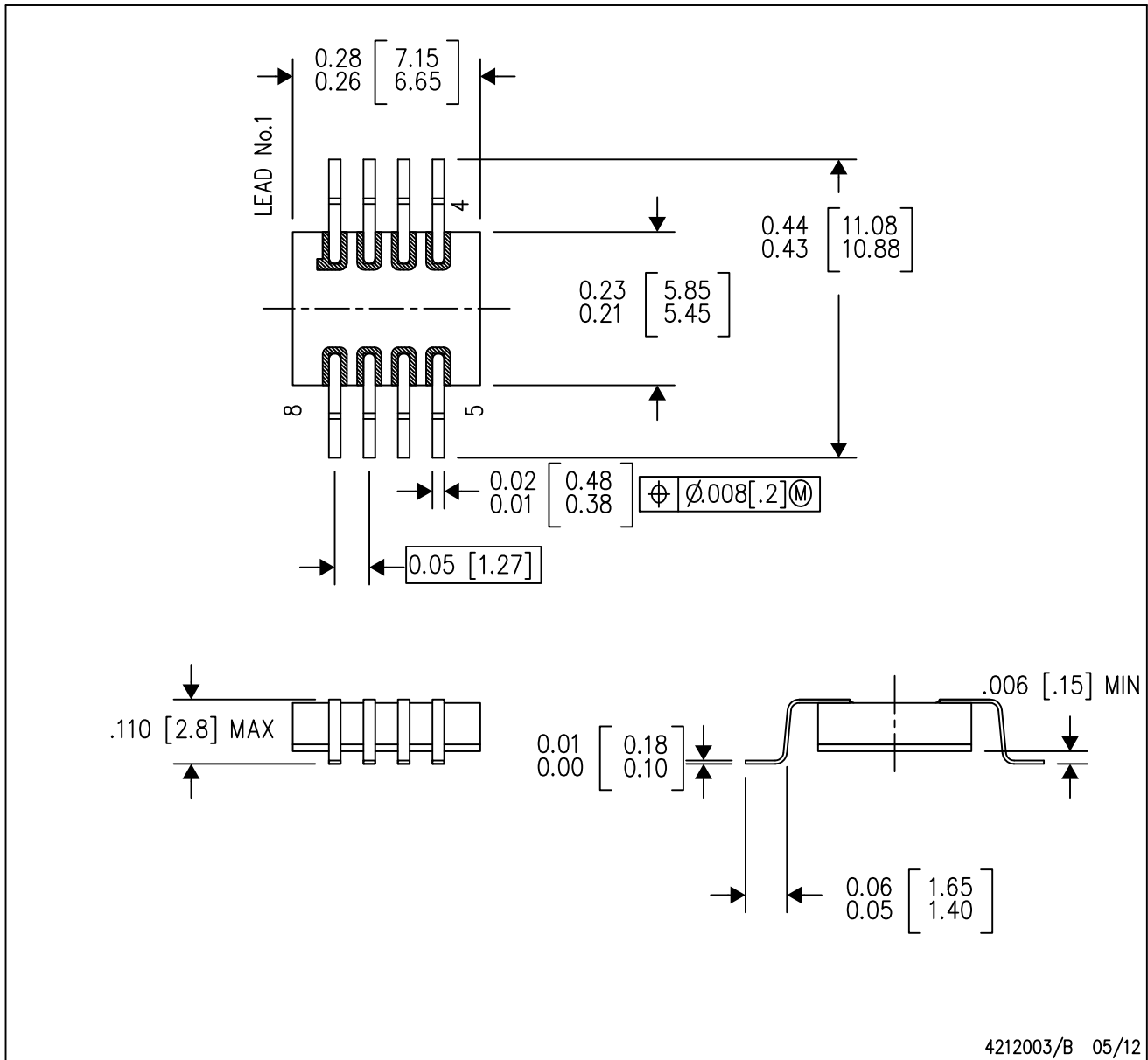

- NOTES:
- A. All linear dimensions are in inches (millimeters).
 - B. This drawing is subject to change without notice.
 - C. This package can be hermetically sealed with a metal lid.
 - D. The terminals will be gold plated.
 - E. Lid is not connected to any lead.

JDJ (R-CDIP-T8)

CERAMIC DUAL IN-LINE PACKAGE

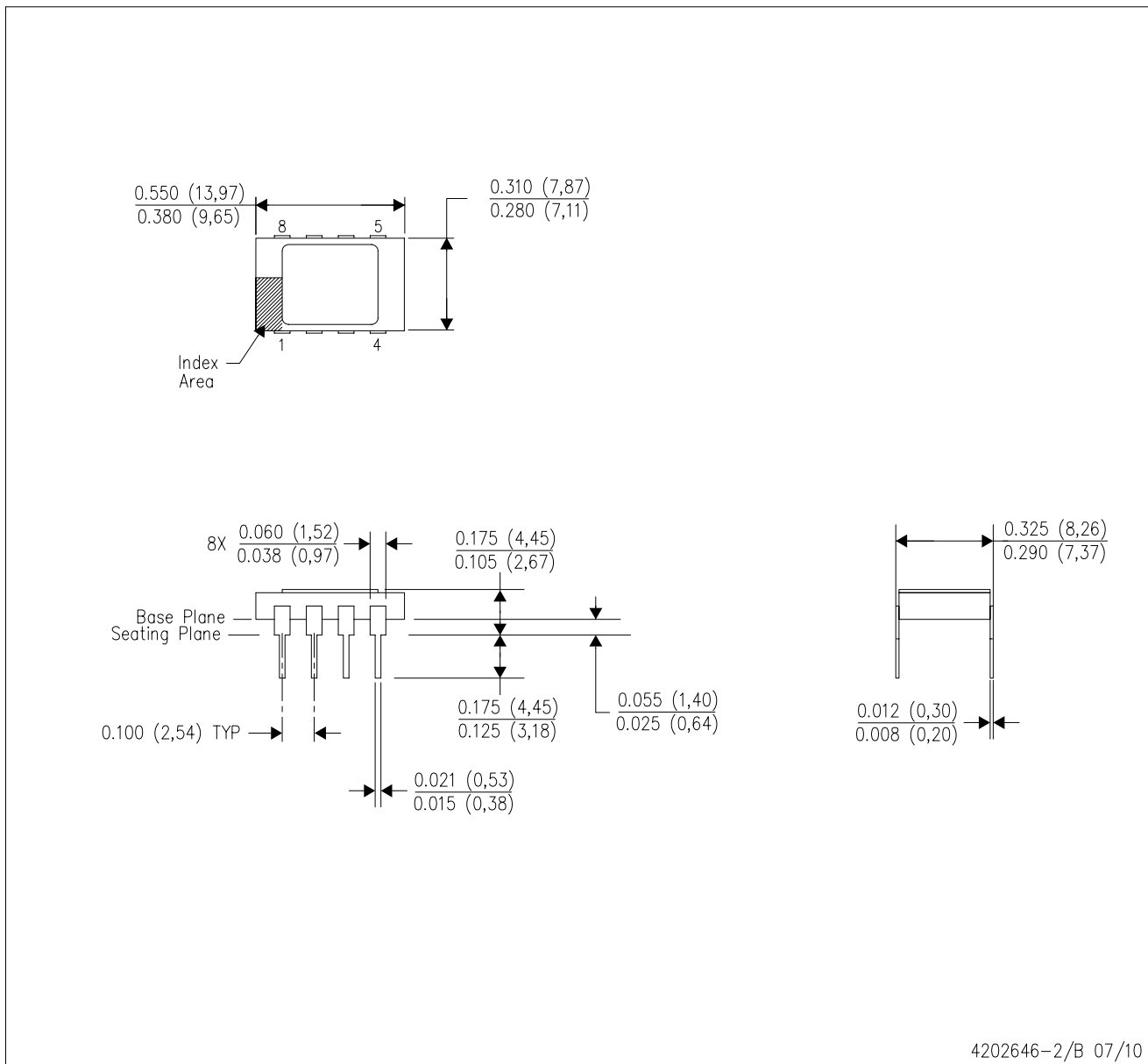

- NOTES:
- All linear dimensions are in inches (millimeters).
 - This drawing is subject to change without notice.
 - Ceramic quad flatpack with flat leads brazed to non-conductive tie bar carrier.
 - This package is hermetically sealed with a metal lid.
 - The leads are gold plated and can be solderdipped.
 - Leads not shown for clarity purposes.
 - Lid and heat sink are connected to GND leads.

D (R-PDSO-G8)

PLASTIC SMALL OUTLINE

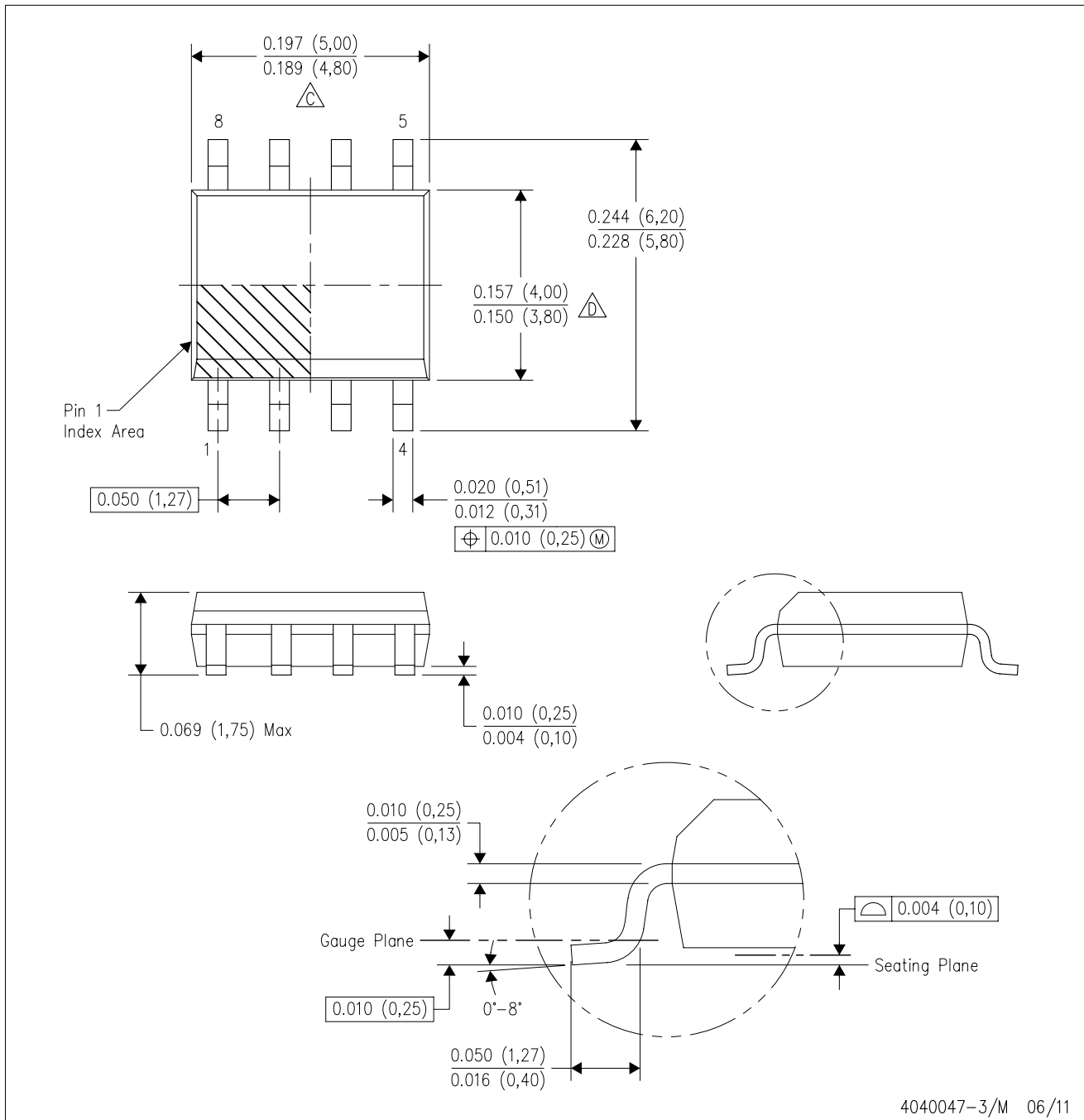

- NOTES:
- A. All linear dimensions are in inches (millimeters).
 - B. This drawing is subject to change without notice.
 - $\triangle C$ Body length does not include mold flash, protrusions, or gate burrs. Mold flash, protrusions, or gate burrs shall not exceed 0.006 (0,15) each side.
 - $\triangle D$ Body width does not include interlead flash. Interlead flash shall not exceed 0.017 (0,43) each side.
 - E. Reference JEDEC MS-012 variation AA.

D (R-PDSO-G8)

PLASTIC SMALL OUTLINE

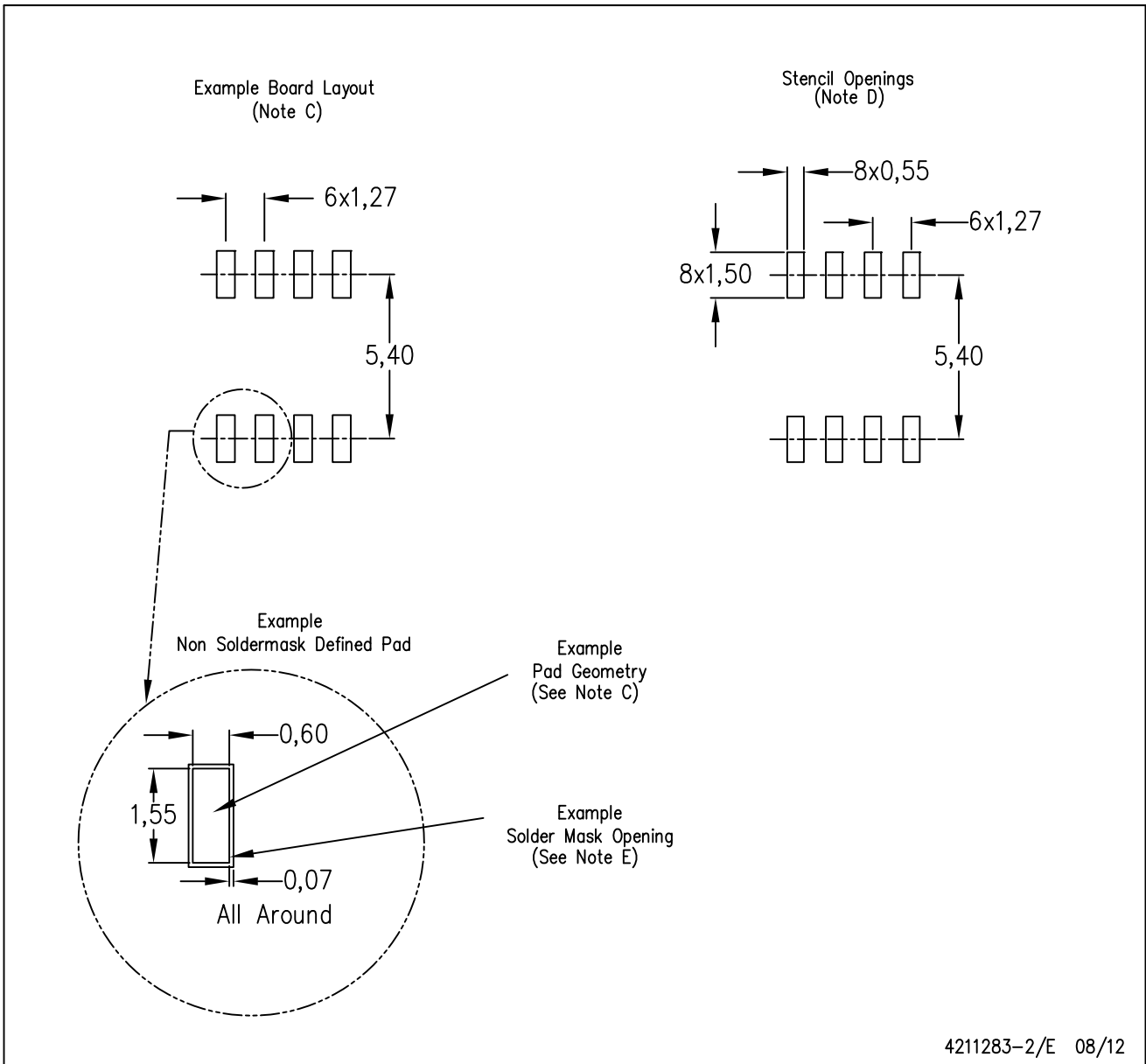

- NOTES:
- A. All linear dimensions are in millimeters.
 - B. This drawing is subject to change without notice.
 - C. Publication IPC-7351 is recommended for alternate designs.
 - D. Laser cutting apertures with trapezoidal walls and also rounding corners will offer better paste release. Customers should contact their board assembly site for stencil design recommendations. Refer to IPC-7525 for other stencil recommendations.
 - E. Customers should contact their board fabrication site for solder mask tolerances between and around signal pads.

IMPORTANT NOTICE

Texas Instruments Incorporated and its subsidiaries (TI) reserve the right to make corrections, enhancements, improvements and other changes to its semiconductor products and services per JESD46, latest issue, and to discontinue any product or service per JESD48, latest issue. Buyers should obtain the latest relevant information before placing orders and should verify that such information is current and complete. All semiconductor products (also referred to herein as "components") are sold subject to TI's terms and conditions of sale supplied at the time of order acknowledgment.

TI warrants performance of its components to the specifications applicable at the time of sale, in accordance with the warranty in TI's terms and conditions of sale of semiconductor products. Testing and other quality control techniques are used to the extent TI deems necessary to support this warranty. Except where mandated by applicable law, testing of all parameters of each component is not necessarily performed.

TI assumes no liability for applications assistance or the design of Buyers' products. Buyers are responsible for their products and applications using TI components. To minimize the risks associated with Buyers' products and applications, Buyers should provide adequate design and operating safeguards.

TI does not warrant or represent that any license, either express or implied, is granted under any patent right, copyright, mask work right, or other intellectual property right relating to any combination, machine, or process in which TI components or services are used. Information published by TI regarding third-party products or services does not constitute a license to use such products or services or a warranty or endorsement thereof. Use of such information may require a license from a third party under the patents or other intellectual property of the third party, or a license from TI under the patents or other intellectual property of TI.

Reproduction of significant portions of TI information in TI data books or data sheets is permissible only if reproduction is without alteration and is accompanied by all associated warranties, conditions, limitations, and notices. TI is not responsible or liable for such altered documentation. Information of third parties may be subject to additional restrictions.

Resale of TI components or services with statements different from or beyond the parameters stated by TI for that component or service voids all express and any implied warranties for the associated TI component or service and is an unfair and deceptive business practice. TI is not responsible or liable for any such statements.

Buyer acknowledges and agrees that it is solely responsible for compliance with all legal, regulatory and safety-related requirements concerning its products, and any use of TI components in its applications, notwithstanding any applications-related information or support that may be provided by TI. Buyer represents and agrees that it has all the necessary expertise to create and implement safeguards which anticipate dangerous consequences of failures, monitor failures and their consequences, lessen the likelihood of failures that might cause harm and take appropriate remedial actions. Buyer will fully indemnify TI and its representatives against any damages arising out of the use of any TI components in safety-critical applications.

In some cases, TI components may be promoted specifically to facilitate safety-related applications. With such components, TI's goal is to help enable customers to design and create their own end-product solutions that meet applicable functional safety standards and requirements. Nonetheless, such components are subject to these terms.

No TI components are authorized for use in FDA Class III (or similar life-critical medical equipment) unless authorized officers of the parties have executed a special agreement specifically governing such use.

Only those TI components which TI has specifically designated as military grade or "enhanced plastic" are designed and intended for use in military/aerospace applications or environments. Buyer acknowledges and agrees that any military or aerospace use of TI components which have **not** been so designated is solely at the Buyer's risk, and that Buyer is solely responsible for compliance with all legal and regulatory requirements in connection with such use.

TI has specifically designated certain components which meet ISO/TS16949 requirements, mainly for automotive use. Components which have not been so designated are neither designed nor intended for automotive use; and TI will not be responsible for any failure of such components to meet such requirements.

Products

| | |
|------------------------------|--|
| Audio | www.ti.com/audio |
| Amplifiers | amplifier.ti.com |
| Data Converters | dataconverter.ti.com |
| DLP® Products | www.dlp.com |
| DSP | dsp.ti.com |
| Clocks and Timers | www.ti.com/clocks |
| Interface | interface.ti.com |
| Logic | logic.ti.com |
| Power Mgmt | power.ti.com |
| Microcontrollers | microcontroller.ti.com |
| RFID | www.ti-rfid.com |
| OMAP Applications Processors | www.ti.com/omap |
| Wireless Connectivity | www.ti.com/wirelessconnectivity |

Applications

| | |
|-------------------------------|--|
| Automotive and Transportation | www.ti.com/automotive |
| Communications and Telecom | www.ti.com/communications |
| Computers and Peripherals | www.ti.com/computers |
| Consumer Electronics | www.ti.com/consumer-apps |
| Energy and Lighting | www.ti.com/energy |
| Industrial | www.ti.com/industrial |
| Medical | www.ti.com/medical |
| Security | www.ti.com/security |
| Space, Avionics and Defense | www.ti.com/space-avionics-defense |
| Video and Imaging | www.ti.com/video |

TI E2E Community

e2e.ti.com



Стандарт Электрон Связь

Мы молодая и активно развивающаяся компания в области поставок электронных компонентов. Мы поставляем электронные компоненты отечественного и импортного производства напрямую от производителей и с крупнейших складов мира.

Благодаря сотрудничеству с мировыми поставщиками мы осуществляем комплексные и плановые поставки широчайшего спектра электронных компонентов.

Собственная эффективная логистика и склад в обеспечивает надежную поставку продукции в точно указанные сроки по всей России.

Мы осуществляем техническую поддержку нашим клиентам и предпродажную проверку качества продукции. На все поставляемые продукты мы предоставляем гарантию .

Осуществляем поставки продукции под контролем ВП МО РФ на предприятия военно-промышленного комплекса России , а также работаем в рамках 275 ФЗ с открытием отдельных счетов в уполномоченном банке. Система менеджмента качества компании соответствует требованиям ГОСТ ISO 9001.

Минимальные сроки поставки, гибкие цены, неограниченный ассортимент и индивидуальный подход к клиентам являются основой для выстраивания долгосрочного и эффективного сотрудничества с предприятиями радиоэлектронной промышленности, предприятиями ВПК и научно-исследовательскими институтами России.

С нами вы становитесь еще успешнее!

Наши контакты:

Телефон: +7 812 627 14 35

Электронная почта: sales@st-electron.ru

Адрес: 198099, Санкт-Петербург,
Промышленная ул, дом № 19, литера Н,
помещение 100-Н Офис 331