

## EVALUATION BOARD FOR Si53x/55x/59x XO's/VCXOs

### Description

This document describes the operation of the Silicon Laboratories Si5xx5x7-EVB evaluation board to evaluate both Silicon Laboratories' Si55x and Si595 VCXOs and Si53x and Si590/591 XO's. The Si53x/55x/59x devices use Silicon Laboratories' advanced DSPLL<sup>®</sup> circuitry to provide a low-jitter clock at high frequencies. The Si55x/Si53x/59x IC-based device is factory configurable for a wide variety of user specifications including frequency, supply voltage, output, and tuning slope. Specific configurations are factory programmed into the Si55x/Si53x/59x at time of shipment, thereby eliminating the long lead times associated with custom oscillators. Si55x/Si53x/59x samples should be ordered at the same time as the Si5xx5x7-EVB since the EVB does not come with the device. This allows end users maximum flexibility. Silicon Laboratories can solder down samples when ordering an EVB; please specify when ordering.

### Features

- Evaluation of Silicon Laboratories' Si55x/53x/59x family
- AC-coupled differential output clocks
- Voltage control ( $V_C$ ) input port (for Si55x/595 devices)
- Jumper selection for multi-frequency outputs
- Jumper selection for output enable

### Functional Block Diagram

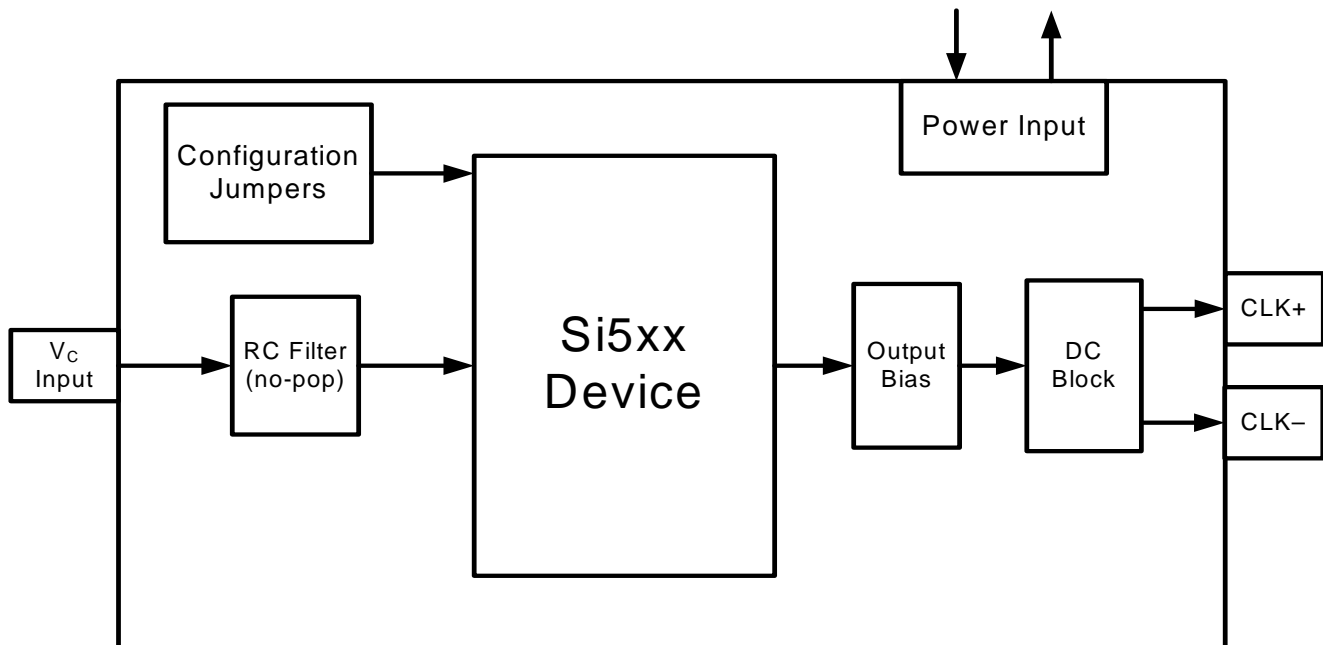

# Si5xx5x7-EVB

## 1. Functional Description

The Si5xx5x7-EVB provides access to all signals for configuring and operating the device. This board allows evaluation of the Si55x/595 VCXO device either by itself (open-loop) or within a prototype PLL (closed-loop). The performance of the Si53x/590/591 XO device can also be evaluated on this board (the V<sub>C</sub> port is not used for XO devices).

**Table 1. Jumper Control**

Part Type	JP1	JP2	JP3	JP4
Si530	N/A	N/A	OE	N/A
Si531	N/A	N/A	N/A	OE
Si532	N/A	N/A	OE	Freq Sel
Si533	N/A	N/A	Freq Sel	OE
Si534	Freq Sel1	Freq Sel2	OE	N/A
Si550	N/A	N/A	OE	V <sub>C</sub>
Si552	N/A	N/A	Freq Sel	V <sub>C</sub>
Si554	Freq Sel1	Freq Sel2	OE	V <sub>C</sub>
Si590	N/A	N/A	OE	N/A
Si591	N/A	N/A	N/A	OE
Si595	N/A	N/A	OE	V <sub>C</sub>

**Notes:**

1. With jumper(s) installed, signal(s) are driven low.
2. With jumper(s) not installed, signal(s) are pulled high.

### 1.1. Power Supply

The Si55x/Si53x/59x devices support operation from nominal voltages of 1.8, 2.5, and 3.3 V. Review the device data sheet and part number for allowed configurations of output buffer type and device power supply.

### 1.2. Voltage Control for VCXOs

The voltage control (V<sub>C</sub>) input of the Si55x/595 device is conveniently accessible through an SMA jack (J3) but can also be driven (and observed) through 100 mil-centered posts (JP4). For prototyping purposes, two 0603 solder pads are located near the device V<sub>C</sub> input (R3 and C3). A traditional PLL might use these as a single-time-constant low-pass filter (RC filter). The EVB is shipped with a 0 Ω resistor soldered at R3; C3 is left open. The voltage control input is not used for XO devices.

### 1.3. Output Clock

Because the Si55x/Si53x/59x devices can support an LVPECL buffer type (in addition to LVDS and CMOS), pulldown resistors (R1 and R2) are available for proper output biasing. For LVPECL buffers, biasing can be achieved through a variety of equivalent circuits; the Si5xx5x7-EVB allows for 130 Ω pulldown resistors. After the output biasing, the high-speed outputs are dc-blocked for connection to differently biased inputs, such as standard test equipment or a phase detector EVB. Please review “1.4. Preparing the EVB” for non-LVPECL devices.

### 1.4. Preparing the EVB

By default, the evaluation board is set up to accept LVPECL configured devices. This configuration uses 130 Ω pull-down resistors to bias the LVPECL output stage. If an LVDS, CMOS, or CML based device is to be installed, the output biasing resistors, R1 and R2, should be removed.

## 2. Schematics

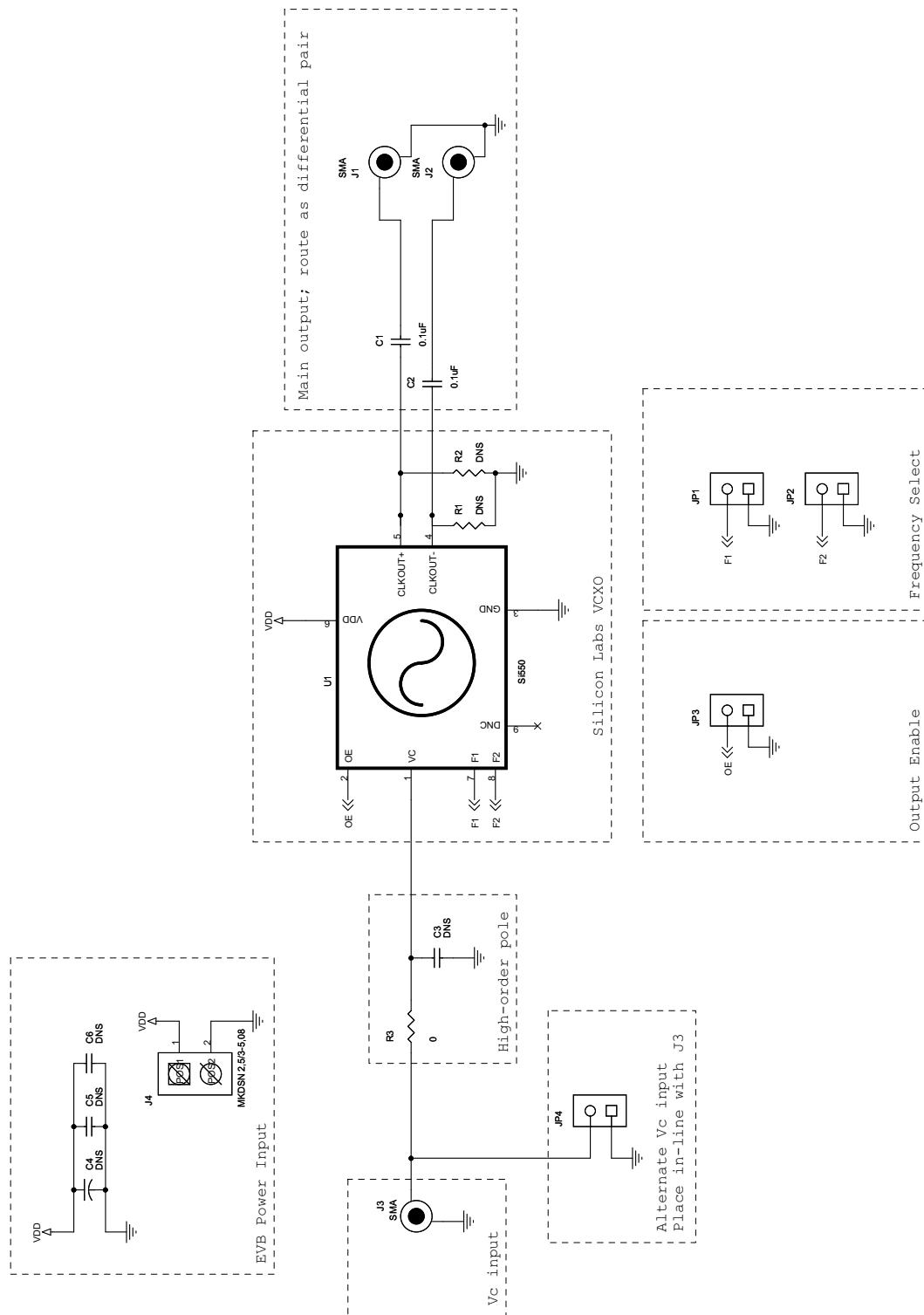

Figure 1. Si5xx5x7-EVB Schematic

# Si5xx5x7-EVB

## 3. Bill of Materials

Table 2. Si5xx5x7-EVB Bill of Materials

Item	Qty	Ref	Description	Mfr #	Mfr
1	2	C1,C2	CAP,SM,0.1 $\mu$ F, 16 V,20%,X7R,0402	C0402X7R160-104KNE	Venkel
2	2	C5	CAP,SM,0.1 $\mu$ F, 16 V,20%,X7R,0603	C0603X7R160-104KNE	Venkel
3	1	C4	CAP,SM,10 $\mu$ F, 10 V,10%,TANTALUM,3216	TA010TCM106KAR	Venkel
4	1	C6	CAP,SM,100 pF, 50 V,10%,C0G,0603	C0603C0G500-101KNE	Venkel
5	4	JP1,JP2, JP3,JP4	CONN,HEADER,2X1	TSW-150-07-T-D or TSW-150-07-T-S	Samtec
6	3	J1,J2,J3	CONN,SMA SIDE MOUNT	901-10003	Amphenol
7	1	J4	CONN,POWER, 2 POSITION	1729018	Phoenix Contact
8	1	R3	RES,SM,0 $\Omega$ ,0603	CR0603-16W-000T	Venkel
9	2	R1,R2	RES,SM,150,1%,0603	CR0603-16W-1500FT	Venkel
<b>No Load</b>					
11	1	C3	CAP,SM,0.1 $\mu$ F, 16 V,20%,X7R,0603	C0603X7R160-104KNE	Venkel
10	1	U1	Si5xx - Not populated	Si5xx	Silicon Laboratories

4. Layout

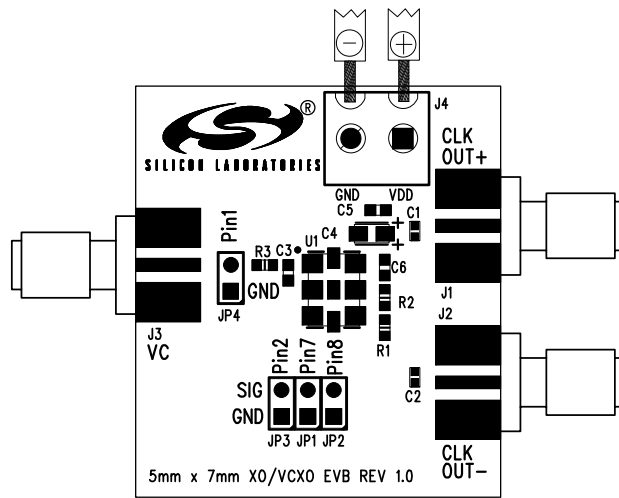

Figure 2. Assembly Drawing

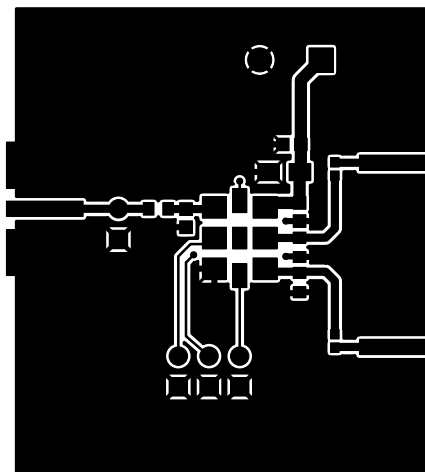

Figure 3. Layer 1 Primary

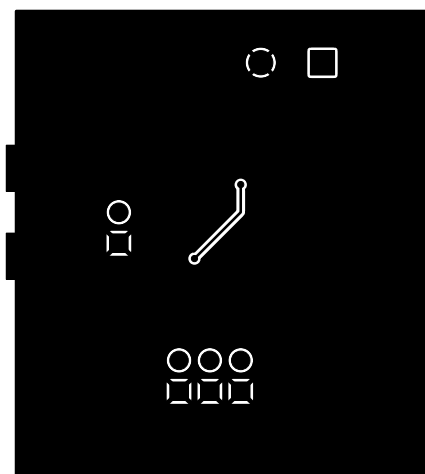

Figure 4. Layer 2 Secondary

# Si5xx5x7-EVB

---

## DOCUMENT CHANGE LIST

### Revision 0.13 to Revision 0.14

- Updated "Bill of Materials," on page 4.
- Updated Figure 2, "Assembly Drawing," on page 5.

### Revision 0.14 to Revision 0.2

- Changed Si5xx-EVB to Si5xx5x7-EVB.

### Revision 0.2 to Revision 0.3

- Changed instances of Si53x/590/591, Si55x, and Si53x to Si53x/55x/59x throughout.
- Updated Table 1, "Jumper Control," on page 2.



## ClockBuilder Pro

One-click access to Timing tools, documentation, software, source code libraries & more. Available for Windows and iOS (CBGo only).

[www.silabs.com/CBPro](http://www.silabs.com/CBPro)



**Timing Portfolio**  
[www.silabs.com/timing](http://www.silabs.com/timing)



**SW/HW**  
[www.silabs.com/CBPro](http://www.silabs.com/CBPro)



**Quality**  
[www.silabs.com/quality](http://www.silabs.com/quality)



**Support and Community**  
[community.silabs.com](http://community.silabs.com)

### Disclaimer

Silicon Labs intends to provide customers with the latest, accurate, and in-depth documentation of all peripherals and modules available for system and software implementers using or intending to use the Silicon Labs products. Characterization data, available modules and peripherals, memory sizes and memory addresses refer to each specific device, and "Typical" parameters provided can and do vary in different applications. Application examples described herein are for illustrative purposes only. Silicon Labs reserves the right to make changes without further notice to the product information, specifications, and descriptions herein, and does not give warranties as to the accuracy or completeness of the included information. Without prior notification, Silicon Labs may update product firmware during the manufacturing process for security or reliability reasons. Such changes will not alter the specifications or the performance of the product. Silicon Labs shall have no liability for the consequences of use of the information supplied in this document. This document does not imply or expressly grant any license to design or fabricate any integrated circuits. The products are not designed or authorized to be used within any FDA Class III devices, applications for which FDA premarket approval is required or Life Support Systems without the specific written consent of Silicon Labs. A "Life Support System" is any product or system intended to support or sustain life and/or health, which, if it fails, can be reasonably expected to result in significant personal injury or death. Silicon Labs products are not designed or authorized for military applications. Silicon Labs products shall under no circumstances be used in weapons of mass destruction including (but not limited to) nuclear, biological or chemical weapons, or missiles capable of delivering such weapons. Silicon Labs disclaims all express and implied warranties and shall not be responsible or liable for any injuries or damages related to use of a Silicon Labs product in such unauthorized applications.

### Trademark Information

Silicon Laboratories Inc.®, Silicon Laboratories®, Silicon Labs®, SiLabs® and the Silicon Labs logo®, Bluegiga®, Bluegiga Logo®, ClockBuilder®, CMEMS®, DSPLL®, EFM®, EFM32®, EFR®, Ember®, Energy Micro, Energy Micro logo and combinations thereof, "the world's most energy friendly microcontrollers", Ember®, EZLink®, EZRadio®, EZRadioPRO®, Gecko®, Gecko OS, Gecko OS Studio, ISOModem®, Precision32®, ProSLIC®, Simplicity Studio®, SiPHY®, Telegesis, the Telegesis Logo®, USBXpress®, Zentri, the Zentri logo and Zentri DMS, Z-Wave®, and others are trademarks or registered trademarks of Silicon Labs. ARM, CORTEX, Cortex-M3 and THUMB are trademarks or registered trademarks of ARM Holdings. Keil is a registered trademark of ARM Limited. Wi-Fi is a registered trademark of the Wi-Fi Alliance. All other products or brand names mentioned herein are trademarks of their respective holders.



Silicon Laboratories Inc.  
400 West Cesar Chavez  
Austin, TX 78701  
USA

<http://www.silabs.com>



**Стандарт  
Электрон  
Связь**

Мы молодая и активно развивающаяся компания в области поставок электронных компонентов. Мы поставляем электронные компоненты отечественного и импортного производства напрямую от производителей и с крупнейших складов мира.

Благодаря сотрудничеству с мировыми поставщиками мы осуществляем комплексные и плановые поставки широчайшего спектра электронных компонентов.

Собственная эффективная логистика и склад в обеспечивает надежную поставку продукции в точно указанные сроки по всей России.

Мы осуществляем техническую поддержку нашим клиентам и предпродажную проверку качества продукции. На все поставляемые продукты мы предоставляем гарантию .

Осуществляем поставки продукции под контролем ВП МО РФ на предприятия военно-промышленного комплекса России , а также работаем в рамках 275 ФЗ с открытием отдельных счетов в уполномоченном банке. Система менеджмента качества компании соответствует требованиям ГОСТ ISO 9001.

Минимальные сроки поставки, гибкие цены, неограниченный ассортимент и индивидуальный подход к клиентам являются основой для выстраивания долгосрочного и эффективного сотрудничества с предприятиями радиоэлектронной промышленности, предприятиями ВПК и научно-исследовательскими институтами России.

С нами вы становитесь еще успешнее!

**Наши контакты:**

**Телефон:** +7 812 627 14 35

**Электронная почта:** [sales@st-electron.ru](mailto:sales@st-electron.ru)

**Адрес:** 198099, Санкт-Петербург,  
Промышленная ул, дом № 19, литера Н,  
помещение 100-Н Офис 331