

Gladius G1050 Series

10.4" Intel® Atom™ Z530P Rugged Tablet PC



Features

- 10.4" AFFS+ TFT Active Matrix with Resistive Touch Panel
- Ultra Low Power Consumption
- Fully Rugged for Mobile POS or Warehousing Application
- Meet MIL-STD-810F, IP54, 4 ft. Drop Resistance
- High Mobility, Multiple Connectivity (Bluetooth/WLAN/3.75G)
- Identification Devices (Barcode Scanner, RFID Reader and MSR)
- Hot-swappable external battery w/ redundant internal battery
- 23-key Keypad with Numeric Keys and Function Keys
- I.P.A. (Isopropyl) Alcohol Clearing Allowed

System

CPU	Intel® Atom™ Z530P 1.6GHz processor
Graphics Controller	Intel® GMA 500
Memory	2GB DDR2 SO-DIMM memory module installed
Chipset	Intel® System Controller Hub US15WPT
BIOS	AMI BIOS
	1 x Integrated microphone
Audio	1 x Integrated 2W speaker
	1 x Earphone jack
Storage	1 x 32GB 1.8" SSD

Peripherals and Devices

Camera	1 x 2.0 megapixels Auto Focus CMOS camera
RFID	Integrated 13.56MHz, ISO 15693/14443A/14443B RFID Reader (distance: 3~5cm; speed: 5 cards/sec) (optional)
Wi-Fi	Integrated WLAN 802.11 b/g/n
Bluetooth	Integrated Bluetooth 2.1 + EDR
GSM/UMTS	Optional HSUPA module (3.75G) for GSM/GPRS/EDGE, EV-DO networks
Barcode Scanner	1 x 1D/2D Barcode scanner (optional)
MSR	Integrated Magnetic Stripe Reader (optional)

I/O Interface

USB Port	1 x USB 2.0 port
SD Card	1 x SD/SDHC slot
Docking Port	1 x 35-pin pogo connector for docking connection
Expansion	1 x ExpressCard/34 or USB 2.0

Button & Indicator

Function Key	10 x Numeric keys (0 ~ 9); 1 x Enter key; 1 x 4-way arrow keys; 4 x Function keys; 1 x ESC key; 1 x Backspace key; 1 x Dot (.) key; 1 x Brightness control key;
Power Button	1 x Power on/off button
	1 x Battery LED
LED Indicator	1 x RFID (optional)/HSUPA (optional) LED
	1 x Bluetooth (optional) LED

LCD Display

Size/Type	10.4" AFFS+ TFT Active Matrix Panel
Max. Resolution	1024 x 768 (XGA) w/ 262,144 colors
	340 cd/m ² (typ.)
Luminance	800 cd/m ² (typ.) for G1050S
Contrast Ratio	600 :1
View Angle (U/D/R/L)	89°/89°/89°/89°
Backlight Type	LED

Touch Screen

Type	Analog Resistive Touch for G1050/G1050S
	Projected Capacitive Touch for G1050C
Light Transparency	80% (typ.)
Controller Interface	USB Interface

Power Supply

Adapter Input	100 ~ 240VAC (Full Range)
Adapter Output	19VDC, 3.42A, 65W
Battery Type	Li-battery pack
Battery Capacity	1 x 1880mAh 3-cell internal battery pack
	1 x 2500mAh 4-cell external battery pack
Battery Operating Time	8 hours (typ.)

Mechanical & Environmental

Operating Temp.	-20 ~ 45°C (-4 ~ 113°F)
Storage Temp.	-20 ~ 60°C (-4 ~ 140°F)
Discharging Temp.	-20 ~ 45°C (-4 ~ 113°F)
Charging Temp.	0 ~ 40°C (32 ~ 104°F)
Operating Humidity	10 ~ 95% @ 45°C (non-condensing)
Dimensions (W x D x H)	205 x 294 x 25 mm (8.07" x 11.57" x 0.98")
Gross Weight	1.1 kg (2.2 lb) for G1050-Lite
Vibration	3 Grms/ 5 ~ 500Hz/ random operation
Shock	40G peak acceleration (11 ms duration)
Transit Drop	4 ft., except the front side
IP Rating	IP54 (whole unit)
Regulatory	CE/FCC Class B

OS Support

Windows 7 Embedded / Windows 7 Professional
Windows XP Embedded / Windows XP Professional

Ordering Information

G1050-Full	10.4" Intel® Atom™ Z530P rugged tablet PC with dual battery packs, camera, Bluetooth, WiFi, HSUPA, RFID reader and barcode scanner
G1050-Lite	10.4" Intel® Atom™ Z530P rugged tablet PC with external battery pack and WiFi
G1050S-Full	10.4" Intel® Atom™ Z530P rugged tablet PC with dual battery packs, camera, Bluetooth, WiFi, HSUPA, RFID reader, barcode scanner and sunlight readable display
G1050S-Lite	10.4" Intel® Atom™ Z530P rugged tablet PC with external battery pack, WiFi and sunlight readable display
G1050C	10.4" Intel® Atom™ Z530P rugged tablet PC with projected capacitive touch screen, dual battery packs, camera, WiFi and Bluetooth

All specifications are subject to change without notice.

Dimensions

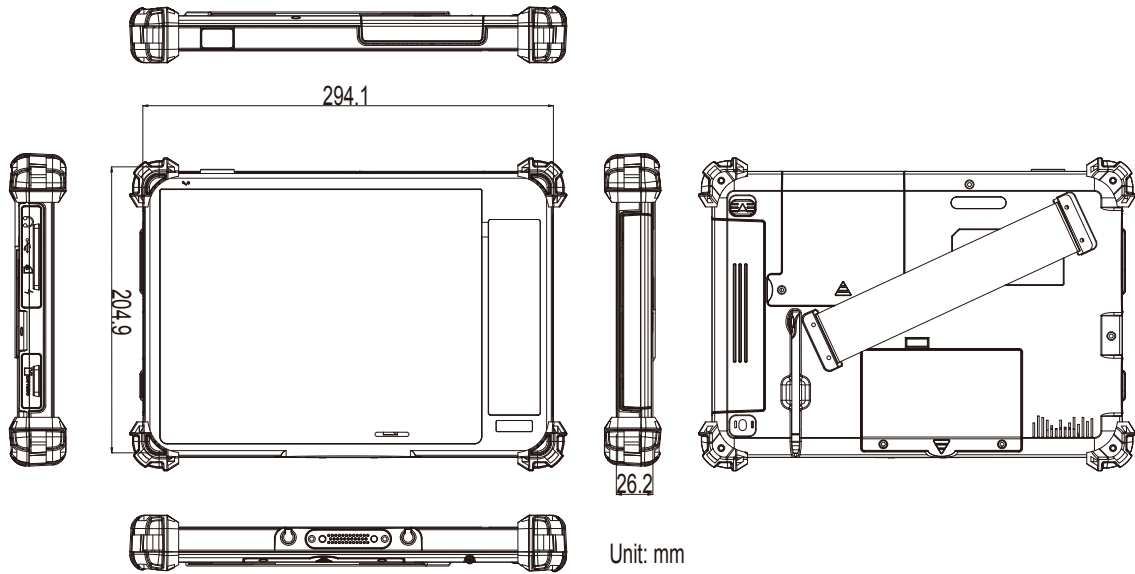

Standard Accessories

Power Adapter 19V/3.42A 65W AC/DC Adapter Kit



Hand Strap 212mm Black Elastic Hand Strap



Stylus For Touch Screen



eBAT-1050 2500mAh External Battery Pack



Optional Accessories

Power Adapter 19V/3.42A 65W AC/DC Adapter Kit



SST-0720 Shoulder Strap, 128 x 3.7cm



eBAT-1050 2500mAh External Battery Pack



iBAT-1040 3-Cell 1880mAh Internal Battery kit



NST-1050 Neck Strap, 120 x 4 x 0.6 cm



VSB-100 VESA-75 to VESA-100 Adapter Bracket



VMB-1050 VESA Mount Bracket for G1050



DTC-1050 Desktop Cradle for G1050/G1050S



CHR-1050 Dual-Bay External Battery Charger



Optional Configuration (CTOS* Kit)

UDG-1050 USB Dongle Kit



RFID-1050 13.56MHz RFID Kit



BarC-1050 1D/2D Barcode Scanner Kit



HSUPA-1050 3.75G HSUPA Wireless Kit



GRS-1050 GPS and RS-232 2in1 Kit



SRS-1050 Smart Card Reader and RS-232 2in1 Kit



MSR-1050 MSR Module Kit



*CTOS means Configure-to-Order Service.

*The GRS, SRS and MSR cannot co-exist on the computer as they occupy the same installation position. Please select any one of them.

All specifications are subject to change without notice.



Стандарт Электрон Связь

Мы молодая и активно развивающаяся компания в области поставок электронных компонентов. Мы поставляем электронные компоненты отечественного и импортного производства напрямую от производителей и с крупнейших складов мира.

Благодаря сотрудничеству с мировыми поставщиками мы осуществляем комплексные и плановые поставки широчайшего спектра электронных компонентов.

Собственная эффективная логистика и склад в обеспечивает надежную поставку продукции в точно указанные сроки по всей России.

Мы осуществляем техническую поддержку нашим клиентам и предпродажную проверку качества продукции. На все поставляемые продукты мы предоставляем гарантию .

Осуществляем поставки продукции под контролем ВП МО РФ на предприятия военно-промышленного комплекса России , а также работаем в рамках 275 ФЗ с открытием отдельных счетов в уполномоченном банке. Система менеджмента качества компании соответствует требованиям ГОСТ ISO 9001.

Минимальные сроки поставки, гибкие цены, неограниченный ассортимент и индивидуальный подход к клиентам являются основой для выстраивания долгосрочного и эффективного сотрудничества с предприятиями радиоэлектронной промышленности, предприятиями ВПК и научно-исследовательскими институтами России.

С нами вы становитесь еще успешнее!

Наши контакты:

Телефон: +7 812 627 14 35

Электронная почта: sales@st-electron.ru

Адрес: 198099, Санкт-Петербург,
Промышленная ул, дом № 19, литера Н,
помещение 100-Н Офис 331