

# PLC-OS...

## PLC INTERFACE With Solid-State Relay, Universal Version

### INTERFACE

Data Sheet  
103148\_en\_02

© PHOENIX CONTACT - 03/2008



## 1 Description

PLC-OS... relay modules, which can be used universally, comprise 6.2 mm basic terminal blocks and plug-in miniature solid-state relays with screw or spring-cage connection.

### 1.1 Input Voltages From 24 V to 230 V

The PLC-OS... is available on the control side in all common industrial voltages from 24 V to 230 V. A further advantage is the ready-integrated input circuit. It consists of a status indicator and polarity reversal protection function, and ensures that the operating state is displayed clearly, also preventing destruction of the optical electronics should the polarity be accidentally reversed.

### 1.2 Plug-In Bridges Save Wiring

The PLC INTERFACE module achieves maximum efficiency with the user-friendly FBST plug-in bridge system. The PLC-OS... makes effective use of the bridging options for the A1/A2 connection on the control side and for the power supply at connection 13 on the load side. Especially effective here are the 500 mm long color-insulated continuous plug-in bridges that can easily be cut to the required length and quickly inserted in the bridge shafts. They eliminate the need for complicated and time-consuming loop bridges.

### 1.3 Additional Advantages

- Switching power of up to 24 V DC/3 A, depending on the type
- IP67-protected fully encapsulated optical electronics
- Available with input or power solid-state relays as an option
- Integrated input circuit
- Solid-state relay can be replaced using an engagement lever
- Wear-resistant switching
- Resistant to vibrations and shocks
- Inflammability class V0 according to UL94



Make sure you always use the latest documentation.  
It can be downloaded at [www.download.phoenixcontact.com](http://www.download.phoenixcontact.com).



A conversion table is available on the Internet at  
[www.download.phoenixcontact.com/general/7000\\_en\\_00.pdf](http://www.download.phoenixcontact.com/general/7000_en_00.pdf).



This data sheet is valid for all products listed on the following page:



## 2 Ordering Data

### PLC INTERFACE With Screw Connection

Description	Type	Order No.	Pcs./Pck.
<b>PLC INTERFACE With Input Solid-State Relay, Universal Version</b>			
PLC INTERFACE, comprising PLC-BSC... basic terminal block and plug-in miniature solid-state relay (see INTERFACE catalog), for mounting on  . Other input voltages on request.	24 V DC	PLCOSC- 24DC/48DC/100	2966728
	120 V AC/110 V DC	PLCOSC-120UC/48DC/100	2966744
	230 V AC/220 V DC <sup>1</sup>	PLCOSC-230UC/48DC/100	2966757
<b>PLC INTERFACE With Power Solid-State Relay, Universal Version</b>			
PLC INTERFACE, comprising PLC-BSC.../21 basic terminal block and plug-in miniature solid-state relay (see INTERFACE catalog), for mounting on  . Other input voltages on request.	24 V DC	PLCOSC- 24DC/24DC/2	2966634
	120 V AC/110 V DC	PLCOSC-120UC/24DC/2	2966650
	230 V AC/220 V DC <sup>1</sup>	PLCOSC-230UC/24DC/2	2966663

<sup>1</sup> The PLC-ATP BK insulating plate must be installed for voltages greater than 250 V (L1, L2, L3) between the same terminal points on adjacent modules (see "Accessories"). FBST 8-PLC... or FBST 500... is then used for potential bridging.

### PLC INTERFACE With Spring-Cage Connection

Description	Type	Order No.	Pcs./Pck.
<b>PLC INTERFACE With Input Solid-State Relay, Universal Version</b>			
PLC INTERFACE, comprising PLC-BSC... basic terminal block and plug-in miniature solid-state relay (see INTERFACE catalog), for mounting on  . Other input voltages on request.	24 V DC	PLCOSP- 24DC/48DC/100	2967549
	120 V AC/110 V DC	PLCOSP-120UC/48DC/100	2967552
	230 V AC/220 V DC <sup>1</sup>	PLCOSP-230UC/48DC/100	2967565
<b>PLC INTERFACE With Power Solid-State Relay, Universal Version</b>			
PLC INTERFACE, comprising PLC-BSC.../21 basic terminal block and plug-in miniature solid-state relay (see INTERFACE catalog), for mounting on  . Other input voltages on request.	24 V DC	PLCOSP- 24DC/24DC/2	2967471
	120 V AC/110 V DC	PLCOSP-120UC/24DC/2	2967484
	230 V AC/220 V DC <sup>1</sup>	PLCOSP-230UC/24DC/2	2967497

<sup>1</sup> The PLC-ATP BK insulating plate must be installed for voltages greater than 250 V (L1, L2, L3) between the same terminal points on adjacent modules (see "Accessories"). FBST 8-PLC... or FBST 500... is then used for potential bridging.



With the 120 V and 230 V modules, an OPT-60DC/... 60 V solid-state relay is normally used due to the input circuit integrated in the basic terminal block.

For the protection of input and output, inductive loads must be dampened with an effective protective circuit.

### Accessories

Description	Type	Order No.	Pcs./Pck.
Insulating plate	PLC-ATP BK	2966841	25



The PLC-ATP BK insulating plate should be used in the following cases: always fit at the start and end of a PLC terminal strip for voltages greater than 250 V (L1, L2, L3) between the same terminal points on adjacent modules (FBST 8-PLC... or FBST 500... can be used for potential bridging) and for safe isolation between adjacent modules.

For additional accessories such as power terminal blocks and plug-in bridges, please refer to the INTERFACE catalog or [www.phoenixcontact.com](http://www.phoenixcontact.com).

### 3 Technical Data

Input Data	PLCOS...48DC/100		PLCOS...24DC/2	
Nominal input voltage <sup>1</sup>	24 V DC	120 V AC/110 V DC 230 V AC/220 V DC	24 V DC	120 V AC/110 V DC 230 V AC/220 V DC
Permissible range (with reference to $U_N$ )	0.8 ... 1.2 x $U_N$	0.8 ... 1.1 x $U_N$	0.8 ... 1.2 x $U_N$	0.8 ... 1.1 x $U_N$
Switching level				
1 signal ("H")	0.8 x $U_N$	0.8 x $U_N$	0.8 x $U_N$	0.8 x $U_N$
0 signal ("L")	0.4 x $U_N$	0.3 x $U_N$	0.4 x $U_N$	0.25 x $U_N$
Typical input current at $U_N$	8 mA	4 mA	9 mA	4 mA
Typical response time at $U_N$	20 $\mu$ s	6 ms	20 $\mu$ s	6 ms
Typical release time at $U_N$	300 $\mu$ s	10 ms	300 $\mu$ s	10 ms
Transmission frequency $f_{limit}$	300 Hz	10 Hz	300 Hz	10 Hz
Input circuit	Yellow LED, protection against polarity reversal, free-wheeling diode	Yellow LED, bridge rectifier	Yellow LED, protection against polarity reversal, free-wheeling diode	Yellow LED, bridge rectifier

<sup>1</sup> The PLC-ATP BK insulating plate must be installed for voltages greater than 250 V (L1, L2, L3) between the same terminal points on adjacent modules (see "Accessories"). FBST 8-PLC... or FBST 500... is then used for potential bridging.

Output Data	PLCOS...48DC/100	PLCOS...24DC/2
Maximum switching voltage	48 V DC	33 V DC
Minimum switching voltage	3 V DC	
Limiting continuous current	100 mA	3 A (see "Derating Curve")
Maximum inrush current	–	15 A (10 ms)
Output configuration	2-wire floating	
Output circuit	Protection against polarity reversal, surge protection	
Voltage drop at maximum limiting continuous current	$\leq 1$ V	$\leq 200$ mV

General Data	
Impulse voltage withstand level	2.5 kV, 50 Hz, 1 min.
Ambient temperature range	
Operation	-25°C ... 60°C
Storage/transport	-40°C ... 85°C
Nominal operating mode	100% operating factor
Inflammability class according to UL 94 (housing)	V0
Standards/specifications <sup>1</sup>	IEC 60664, IEC 60664 A, DIN VDE 0110 (basic insulation)
Pollution degree	2
Surge voltage category	III
Mounting position	Any
Mounting	Can be aligned without spacing
Conductor cross-section	
Solid, with screw connection	0.14 mm <sup>2</sup> ... 2.5 mm <sup>2</sup> (26 - 14 AWG)
Stranded, with screw connection	0.14 mm <sup>2</sup> ... 1.5 mm <sup>2</sup> (26 - 14 AWG)
Solid, with spring-cage connection	0.2 mm <sup>2</sup> ... 2.5 mm <sup>2</sup> (24 - 14 AWG)
Stranded, with spring-cage connection	0.2 mm <sup>2</sup> ... 1.5 mm <sup>2</sup> (24 - 14 AWG)
Stripping length	
Screw connection	10 mm
Spring-cage connection	8 mm
Dimensions (W x H x D)	6.2 mm x 94 mm x 80 mm
Housing material	Polyamide PA, green

<sup>1</sup> The PLC-ATP BK insulating plate must be installed for safe isolation between adjacent modules (see "Accessories"). FBST 8-PLC... or FBST 500... is then used for potential bridging.

**Tests/Approvals**

CE

CE

UL



GL



**4 Block Diagram**

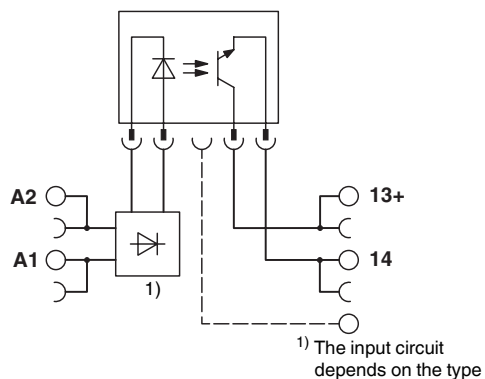

**5 Derating Curve**

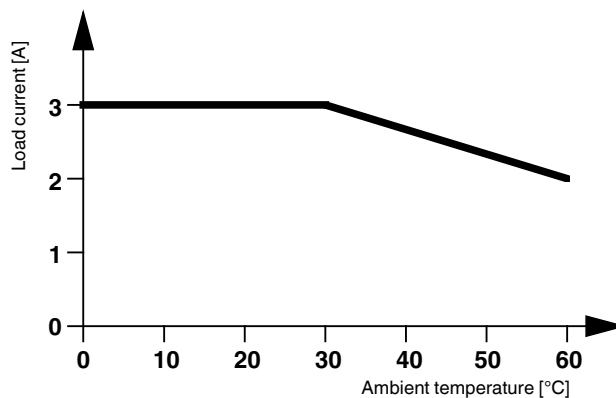



## Стандарт Электрон Связь

Мы молодая и активно развивающаяся компания в области поставок электронных компонентов. Мы поставляем электронные компоненты отечественного и импортного производства напрямую от производителей и с крупнейших складов мира.

Благодаря сотрудничеству с мировыми поставщиками мы осуществляем комплексные и плановые поставки широчайшего спектра электронных компонентов.

Собственная эффективная логистика и склад в обеспечивает надежную поставку продукции в точно указанные сроки по всей России.

Мы осуществляем техническую поддержку нашим клиентам и предпродажную проверку качества продукции. На все поставляемые продукты мы предоставляем гарантию .

Осуществляем поставки продукции под контролем ВП МО РФ на предприятия военно-промышленного комплекса России , а также работаем в рамках 275 ФЗ с открытием отдельных счетов в уполномоченном банке. Система менеджмента качества компании соответствует требованиям ГОСТ ISO 9001.

Минимальные сроки поставки, гибкие цены, неограниченный ассортимент и индивидуальный подход к клиентам являются основой для выстраивания долгосрочного и эффективного сотрудничества с предприятиями радиоэлектронной промышленности, предприятиями ВПК и научно-исследовательскими институтами России.

С нами вы становитесь еще успешнее!

### Наши контакты:

**Телефон:** +7 812 627 14 35

**Электронная почта:** [sales@st-electron.ru](mailto:sales@st-electron.ru)

**Адрес:** 198099, Санкт-Петербург,  
Промышленная ул, дом № 19, литера Н,  
помещение 100-Н Офис 331