

***RoHS Compliant***

## **USB Flash Drive**

***AH321 Product Specifications***

**March 23, 2017**

***Version 2.5***



**Apacer**  
*Access the best*

***Apacer Technology Inc.***

1F, No.32, Zhongcheng Rd., Tucheng Dist., New Taipei City, Taiwan, R.O.C

Tel: +886-2-2267-8000 Fax: +886-2-2267-2261

[www.apacer.com](http://www.apacer.com)

## FEATURES:

- **USB2.0 High-Speed and USB1.1 Full-Speed Compatible Interface**
- **Capacity**
  - For SLC: 256, 512 MB  
1, 2, 4, 8, 16, 32 GB
  - For MLC: 4, 8, 16, 32, 64 GB
- **NAND Flash Type: MLC & SLC**
- **Performance\***
  - Sustained read: up to 34 MB/s
  - Sustained write: up to 22 MB/s
- **Flash Management**
  - Implements advanced wear-leveling algorithms to substantially increase longevity of flash media
  - BCH (24 bit) Error Detection Code/Error Correction Code (EDC/ECC)
  - S.M.A.R.T.
- **MTBF**
  - SLC: 2,000,000 hours
  - MLC: 2,000,000 hours
- **Temperature Range**
  - Operating:  
Standard: 0°C to 70°C  
Extended: -40°C to 85°C
  - Storage: -40°C to 100°C
- **Power Consumption**
  - Active mode: 185 mA
  - Idle mode: 65 mA
  - Operating voltage: 5V
- **Support Non-Removable Setting**
- **LED Indicators for Drive Behavior**
- **OS Support**
  - Windows: WinXP/7 or later
  - Mac: 10.2.8 or later
  - Linux: 2.4.10 or later
- **Dimensions:** 53.60 x 19.00 x 8.00, unit: mm
- **EMC:** FCC, CE
- **RoHS Compliant**

\*Varies from capacities. The results for performance and power consumption addressed here are typical and may vary in real world platforms.

---

## Table of Contents

<b>1. General Description .....</b>	<b>3</b>
1.1 Functional Block .....	3
1.2 Error Correction Code (ECC) .....	3
1.3 Wear-Leveling .....	3
1.4 S.M.A.R.T. ....	3
<b>2. General Specifications.....</b>	<b>4</b>
2.1 General Specifications.....	4
2.2 Performance Specifications – SLC.....	4
2.3 Performance Specifications – MLC .....	4
<b>3. Electrical Specifications .....</b>	<b>5</b>
<b>4. Physical Dimensions .....</b>	<b>6</b>
<b>5. Product Ordering Information.....</b>	<b>7</b>
5.1 Product Code Designations.....	7
5.2 Valid Combinations.....	8
5.2.1 AH321 (SLC).....	8
5.2.2 AH321 (MLC).....	8

## 1. General Description

Apacer's USB FLASH Drive (UFD) is a high performance flash disk drive designed offering portable storage solutions. UFDs can be plugged into a standard USB 2.0 connector commonly found in desktops, portable computers and even enterprise PC systems. Apacer's UFDs have an efficient built-in microcontroller and file management firmware that ensures ideal performance, functionality and reliability. This product is well suited for portable flash storage applications while operating at minimal power consumption.

### 1.1 Functional Block



Figure 1-1 Functional Block Diagram

### 1.2 Error Correction Code (ECC)

Apacer's USB FLASH Drive (UFD) uses BCH Error Detection Code (EDC) and Error Correction Code (ECC) algorithms which correct up to 24 random single-bit errors for each 1024-byte block of data.

### 1.3 Wear-Leveling

Flash memory can be erased a limited number of times. In a typical application, and especially if a file system is used, specific pages are constantly updated (e.g., the page that contains the FAT, registry, etc.). Without any special handling, these pages would wear out more rapidly than other pages, reducing the lifetime of the entire flash. To overcome this inherent deficiency, Apacer's USB FLASH Drive (UFD) uses wear-leveling algorithm. This wear-leveling algorithm ensures that consecutive writes of a specific sector are not written physically to the same page in the flash. This distributes flash media usage evenly across all pages, thereby maximizing flash lifetime. The wear-leveling mechanism provides write/erase cycles for reliable data storage over an extended period.

### 1.4 S.M.A.R.T.

S.M.A.R.T. is an abbreviation for Self-Monitoring, Analysis and Reporting Technology, a self-monitoring system that provides indicators of drive health as well as potential disk problems. It serves as a warning for users from unscheduled downtime by monitoring and displaying critical drive information. Ideally, this should allow taking proactive actions to prevent drive failure and make use of S.M.A.R.T. information for future product development reference.

## 2. General Specifications

### 2.1 General Specifications

Table 2-1 General Specifications

Item	Description
Interface	High-speed USB2.0 compliant; backward compatible with USB 1.1
Performance*	SLC: up to 34 MB/s (read); 22 MB/s (write) MLC: up to 33 MB/s (read); 16 MB/s (write)
Temperature	0°C to 70°C (Standard); -40°C to 85°C (Extended)
EMC	FCC, CE
MTBF	2,000,000 hours (SLC); 2,000,000 (MLC)
Shock	Operation: 50G, 11ms Non-operation: 1,500G, 0.5ms
Vibration	Operation: 7.69 Grms, 20~2000 Hz/random (complies with MIL-STD-810G) Non-operation: 15 G, 10 ~ 2000 Hz/sine

Note: Results may vary from flash configurations or host system settings.

### 2.2 Performance Specifications – SLC

Table 2-2 Performance Specifications (SLC)

Capacity \ Performance	256 MB	512 MB	1 GB	2 GB	4 GB	8 GB	16 GB	32 GB
Sustained Read (MB/s)	31	31	32	34	28	32	34	31
Sustained Write (MB/s)	10	15	19	19	21	15	22	21

Note: Results may vary depending on flash configurations or host system settings.

### 2.3 Performance Specifications – MLC

Table 2-3 Performance Specifications (MLC)

Capacity \ Performance	4 GB	8 GB	16 GB	32 GB	64 GB
Sustained Read (MB/s)	32	32	33	33	29
Sustained Write (MB/s)	10	10	14	16	10

Note: Results may vary depending on flash configurations or host system settings.

---

## 3. Electrical Specifications

**Caution: Absolute Maximum Stress Ratings** – Applied conditions greater than those listed under “Absolute Maximum Stress Ratings” may cause permanent damage to the device. This is a stress rating only and functional operation of the device at these conditions or conditions greater than those defined in the operational sections of this data sheet is not implied. Exposure to absolute maximum stress rating conditions may affect device reliability.

**Table 3-1** Absolute Stress Rating

Parameters	Conditions
Ambient temperature	0°C to 70°C (Standard); -40°C to 85°C (Extended)
Storage temperature	-40°C to 100°C
Required power supply	4.5-5.5V
Input power (VDD )	-0.3V (min.) to 5.5V (max.)
Voltage on any pin except VDD with respect to GND	-0.3V (min.) to VDD + 0.3V (max.)

## 4. Physical Dimensions

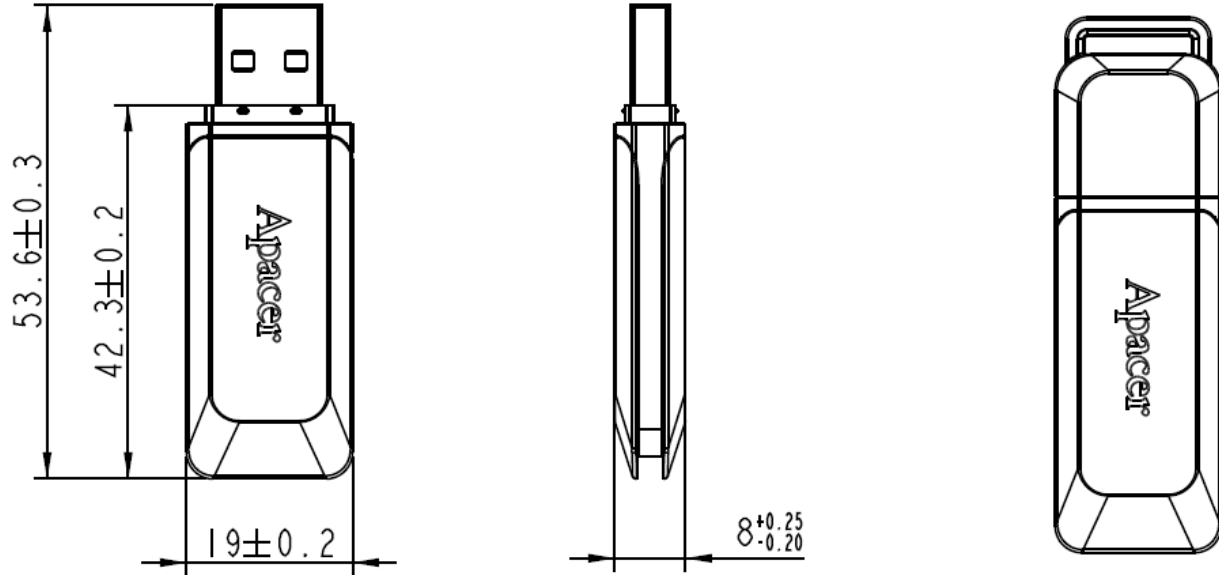

## 5. Product Ordering Information

### 5.1 Product Code Designations





---

## 5.2 Valid Combinations

---

### 5.2.1 AH321 (SLC)

Capacity	Standard Temperature	Extended Temperature
256 MB	APHA256MR13CG-6T	APHA256MT13EG-6T
512 MB	APHA512MR13CG-6T	APHA512MT13EG-6T
1 GB	APHA001GR13CG-6T	APHA001GT13EG-6T
2 GB	APHA002GR13CG-6T	APHA002GT13EG-6T
4 GB	APHA004GR13CG-6T	APHA004GT13EG-6T
8 GB	APHA008GR13CG-6T	APHA008GT13EG-6T
16 GB	APHA016GR13CG-6T	APHA016GT13EG-6T
32 GB	APHA032GR13CG-6T	APHA032GT13EG-6T

### 5.2.2 AH321 (MLC)

Capacity	Standard Temperature	Extended Temperature
4 GB	APHA004GR13CG-2CM	APHA004GT13EG-2CM
8 GB	APHA008GR13CG-2CM	APHA008GT13EG-2CM
16 GB	APHA016GR13CG-2CM	APHA016GT13EG-2CM
32 GB	APHA032GR13CG-2CM	APHA032GT13EG-2CM
64 GB	APHA064GR13CG-2CM	APHA064GT13EG-2CM

## Revision History

Revision	Description	Date
1.0	Official Release	August 11 <sup>th</sup> , 2011
1.1	Updated Product Ordering Information	June 20 <sup>th</sup> , 2012
1.2	Updated Product Ordering Information - contents relating to extended temperature are removed	July 2 <sup>nd</sup> , 2012
1.3	Updated read/write performance due to change in NAND flash use Updated addresses of Taiwan headquarter and the office in India	July 30 <sup>th</sup> , 2013
1.4	Added performance tables	June 4 <sup>th</sup> , 2014
1.5	Added SLC extended temperature models	October 17 <sup>th</sup> , 2014
1.6	Updated Product Ordering Information	November 17 <sup>th</sup> , 2014
1.7	Updated Product Ordering Information	February 17 <sup>th</sup> , 2015
1.8	Added storage temperature	November 11 <sup>th</sup> , 2015
1.9	Added 64GB support	November 26 <sup>th</sup> , 2015
2.0	- Revised mechanical specifications - Added non-removable setting and OS support on Features page - Added block diagram - Added shock and vibration specifications - Revised product ordering information	June 7 <sup>th</sup> , 2016
2.1	Added SLC&MLC to file name	October 3 <sup>rd</sup> , 2016
2.2	Revised storage temperature	December 13 <sup>th</sup> , 2016
2.3	- Updated MTBF hours for MLC and shock specifications - Updated product ordering information	February 16 <sup>th</sup> , 2017
2.4	- Updated mechanical specifications - Added S.M.A.R.T to Flash Management and LED Indicators for Drive Behavior on Features page - Added 1.4 S.M.A.R.T. - Updated product ordering information for SLC except 128MB	March 20 <sup>th</sup> , 2017
2.5	- Removed 128GB support - Updated ECC description on Features page - Removed flash types including Samsung SLC and Micron SLC from product code designations	March 23 <sup>rd</sup> , 2017

---

## Global Presence

<b>Taiwan (Headquarters)</b>	<b>Apacer Technology Inc.</b> Apacer Technology Inc. 1F., No.32, Zhongcheng Rd., Tucheng Dist., New Taipei City 236, Taiwan R.O.C. Tel: 886-2-2267-8000 Fax: 886-2-2267-2261 <a href="mailto:amtsales@apacer.com">amtsales@apacer.com</a>
<b>U.S.A.</b>	<b>Apacer Memory America, Inc.</b> 46732 Lakeview Blvd., Fremont, CA 94538 Tel: 1-408-518-8699 Fax: 1-510-249-9551 <a href="mailto:sa@apacerus.com">sa@apacerus.com</a>
<b>Japan</b>	<b>Apacer Technology Corp.</b> 5F, Matsura Bldg., Shiba, Minato-Ku Tokyo, 105-0014, Japan Tel: 81-3-5419-2668 Fax: 81-3-5419-0018 <a href="mailto:jpservices@apacer.com">jpservices@apacer.com</a>
<b>Europe</b>	<b>Apacer Technology B.V.</b> Science Park Eindhoven 5051 5692 EB Son, The Netherlands Tel: 31-40-267-0000 Fax: 31-40-290-0686 <a href="mailto:sales@apacer.nl">sales@apacer.nl</a>
<b>China</b>	<b>Apacer Electronic (Shanghai) Co., Ltd</b> Room D, 22/FL, No.2, Lane 600, JieyunPlaza, Tianshan RD, Shanghai, 200051, China Tel: 86-21-6228-9939 Fax: 86-21-6228-9936 <a href="mailto:sales@apacer.com.cn">sales@apacer.com.cn</a>
<b>India</b>	<b>Apacer Technologies Pvt Ltd,</b> Unit No.201, "Brigade Corner", 7 <sup>th</sup> Block Jayanagar, Yediyur Circle, Bangalore – 560082, India Tel: 91-80-4152-9061 Fax: 91-80-4170-0215 <a href="mailto:sales_india@apacer.com">sales_india@apacer.com</a>



## Стандарт Электрон Связь

Мы молодая и активно развивающаяся компания в области поставок электронных компонентов. Мы поставляем электронные компоненты отечественного и импортного производства напрямую от производителей и с крупнейших складов мира.

Благодаря сотрудничеству с мировыми поставщиками мы осуществляем комплексные и плановые поставки широчайшего спектра электронных компонентов.

Собственная эффективная логистика и склад в обеспечивает надежную поставку продукции в точно указанные сроки по всей России.

Мы осуществляем техническую поддержку нашим клиентам и предпродажную проверку качества продукции. На все поставляемые продукты мы предоставляем гарантию .

Осуществляем поставки продукции под контролем ВП МО РФ на предприятия военно-промышленного комплекса России , а также работаем в рамках 275 ФЗ с открытием отдельных счетов в уполномоченном банке. Система менеджмента качества компании соответствует требованиям ГОСТ ISO 9001.

Минимальные сроки поставки, гибкие цены, неограниченный ассортимент и индивидуальный подход к клиентам являются основой для выстраивания долгосрочного и эффективного сотрудничества с предприятиями радиоэлектронной промышленности, предприятиями ВПК и научно-исследовательскими институтами России.

С нами вы становитесь еще успешнее!

### Наши контакты:

**Телефон:** +7 812 627 14 35

**Электронная почта:** [sales@st-electron.ru](mailto:sales@st-electron.ru)

**Адрес:** 198099, Санкт-Петербург,  
Промышленная ул, дом № 19, литера Н,  
помещение 100-Н Офис 331