

# Optocoupler with Phototransistor Output

## Description

The CNY65Exi consists of a phototransistor optically coupled to a gallium arsenide infrared-emitting diode in a 4-lead plastic package.

The single components are mounted in opposite one-another, providing a distance between input and output for highest safety requirements of > 3 mm.

## Applications

Galvanically separated circuits, suitable for intrinsic safety circuits

Electrical apparatus used in a potentially explosive atmosphere:

EN 50014-1977/VDE 0171 Part 1/5.78

General instructions

EN 50020-1977/VDE 0171 Part 7/5.78

Intrinsic safety 'i' section: 5.5, 5.5.4, 5.7

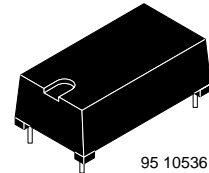

95 10536

## Features

- Suitable for intrinsic safety circuits according to test certificate No. Ex-81/2158 of PTB
- Isolation material according to UL94 – VO – flammability class
- Low temperature coefficient of CTR
- Creepage current resistance of isolation material according to VDE 0303/DIN 53480:  $KC \geq 475$
- Isolation test voltage 11.6 kV
- Test class 25/100/21 DIN 40045
- Very low coupling capacity of typical 0.3 pF therefore high noise voltage resistant
- Current Transfer Ratio (CTR) = 50 to 300%
- Coupling System J

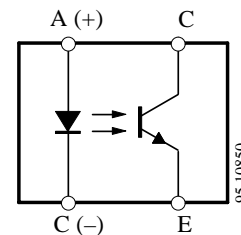

95 10850



## Order Instruction

Ordering Code	CTR Ranking	Remarks
CNY65Exi	50 to 300%	Exi = Intrinsic safety



## Absolute Maximum Ratings

### Input (Emitter)

Parameter	Test Conditions	Symbol	Value	Unit
Reverse voltage		$V_R$	5	V
Forward Current		$I_F$	75	mA
Forward surge current	$t_p \leq 10 \mu s$	$I_{FSM}$	1.5	A
Power dissipation	$T_{amb} \leq 25^\circ C$	$P_V$	120	mW
Junction temperature		$T_j$	100	$^\circ C$

### Output (Detector)

Parameter	Test Conditions	Symbol	Value	Unit
Collector emitter voltage		$V_{CEO}$	32	V
Emitter collector voltage		$V_{ECO}$	7	V
Collector current		$I_C$	50	mA
Collector peak current	$t_p/T = 0.5, t_p \leq 10 ms$	$I_{CM}$	100	mA
Power dissipation	$T_{amb} \leq 25^\circ C$	$P_V$	130	mW
Junction temperature		$T_j$	100	$^\circ C$

### Coupler

Parameter	Test Conditions	Symbol	Value	Unit
DC isolation test voltage	$t = 1 min$	$V_{IO}$	11.6	kV
Total power dissipation	$T_{amb} \leq 25^\circ C$	$P_{tot}$	250	mW
Ambient temperature range		$T_{amb}$	-55 to +85	$^\circ C$
Storage temperature range		$T_{stg}$	-55 to +100	$^\circ C$
Soldering temperature	2 mm from case, $t \leq 10 s$	$T_{sd}$	260	$^\circ C$



### Electrical Characteristics ( $T_{amb} = 25^{\circ}\text{C}$ )

#### Input (Emitter)

Parameter	Test Conditions	Symbol	Min.	Typ.	Max.	Unit
Forward voltage	$I_F = 50 \text{ mA}$	$V_F$		1.25	1.6	V

#### Output (Detector)

Parameter	Test Conditions	Symbol	Min.	Typ.	Max.	Unit
Collector emitter voltage	$I_C = 1 \text{ mA}$	$V_{CEO}$	32			V
Emitter collector voltage	$I_E = 100 \mu\text{A}$	$V_{ECO}$	7			V
Collector dark current	$V_{CE} = 20 \text{ V}, I_f = 0, E = 0$	$I_{CEO}$			200	nA

#### Coupler

Parameter	Test Conditions	Symbol	Min.	Typ.	Max.	Unit
DC isolation test voltage	$t = 1 \text{ min}$	$V_{IO}^{1)}$	11.6			kV
Isolation resistance	$V_{IO} = 1 \text{ kV}$ , 40% relative humidity	$R_{IO}^{1)}$		$10^{12}$		$\Omega$
Collector saturation voltage	$I_F = 10 \text{ mA}, I_C = 1 \text{ mA}$	$V_{CEsat}$			0.3	V
Cut-off frequency	$V_{CE} = 5 \text{ V}, I_F = 10 \text{ mA}$ , $R_L = 100 \Omega$	$f_c$	110			kHz
Coupling capacitance	$f = 1 \text{ MHz}$	$C_k$		0.3		pF

<sup>1)</sup> Related to standard climate 23/50 DIN 50014

#### Current Transfer Ratio (CTR)

Parameter	Test Conditions	Type	Symbol	Min.	Typ.	Max.	Unit
$I_C/I_F$	$V_{CE} = 5 \text{ V}, I_F = 10 \text{ mA}$	CNY65Exi	CTR	0.5	1	3	

## Switching Characteristics

Parameter	Test Conditions	Symbol	Typ.	Unit
Delay time	$V_S = 5\text{ V}$ , $I_C = 5\text{ mA}$ , $R_L = 100\ \Omega$ (see figure 1)	$t_d$	2.6	$\mu\text{s}$
Rise time		$t_r$	2.4	$\mu\text{s}$
Fall time		$t_f$	2.4	$\mu\text{s}$
Storage time		$t_s$	0.3	$\mu\text{s}$
Turn-on time		$t_{on}$	5.0	$\mu\text{s}$
Turn-off time		$t_{off}$	3.0	$\mu\text{s}$
Turn-on time	$V_S = 5\text{ V}$ , $I_F = 10\text{ mA}$ , $R_L = 1\text{ k}\Omega$ (see figure 2)	$t_{on}$	25.0	$\mu\text{s}$
Turn-off time		$t_{off}$	42.5	$\mu\text{s}$

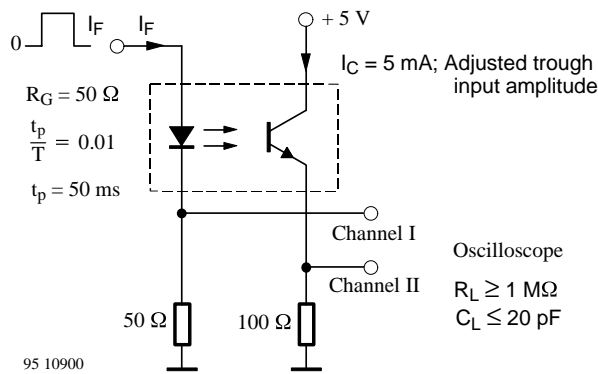

Figure 1. Test circuit, non-saturated operation

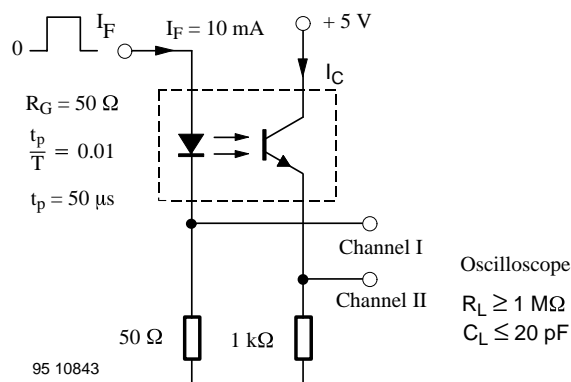

Figure 2. Test circuit, saturated operation

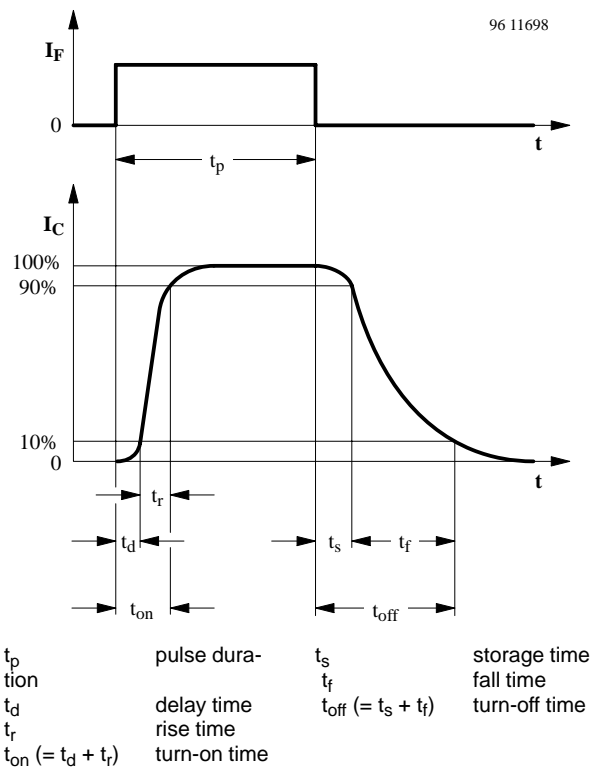

Figure 3. Switching times

### Typical Characteristics ( $T_{amb} = 25^{\circ}\text{C}$ , unless otherwise specified)

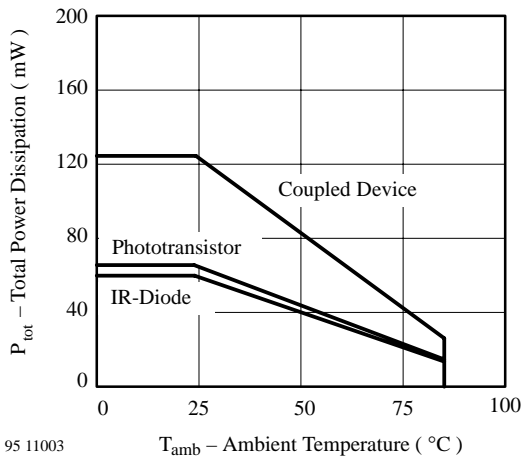

Figure 4. Total Power Dissipation vs. Ambient Temperature

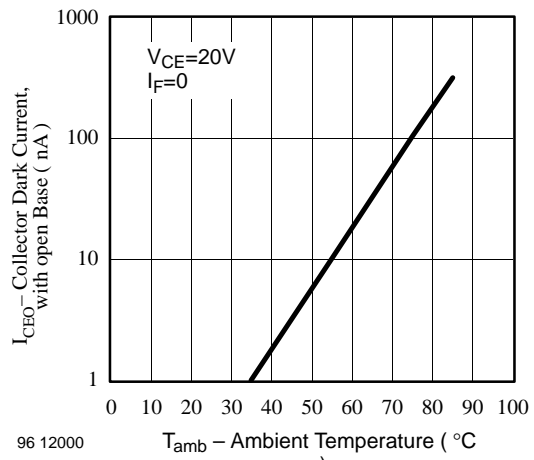

Figure 7. Collector Dark Current vs. Ambient Temperature

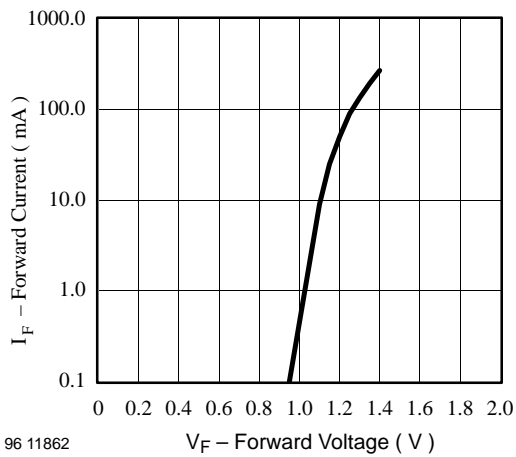

Figure 5. Forward Current vs. Forward Voltage

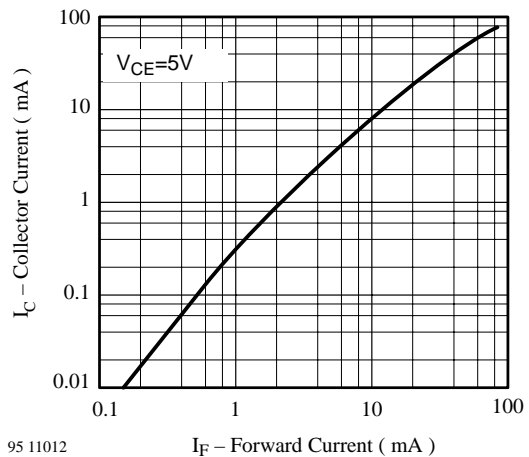

Figure 8. Collector Current vs. Forward Current

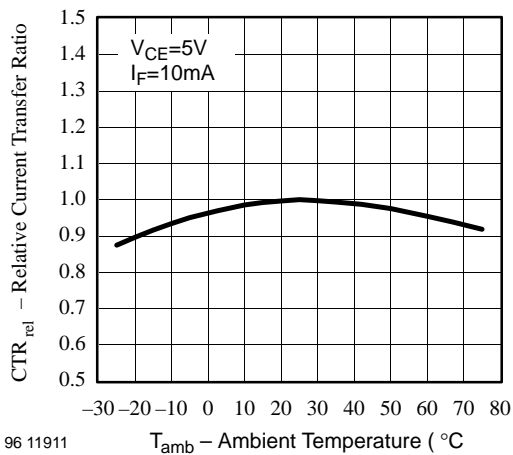

Figure 6. Relative Current Transfer Ratio vs. Ambient Temperature

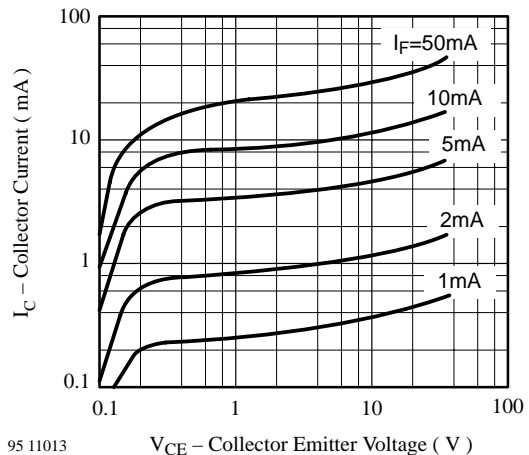
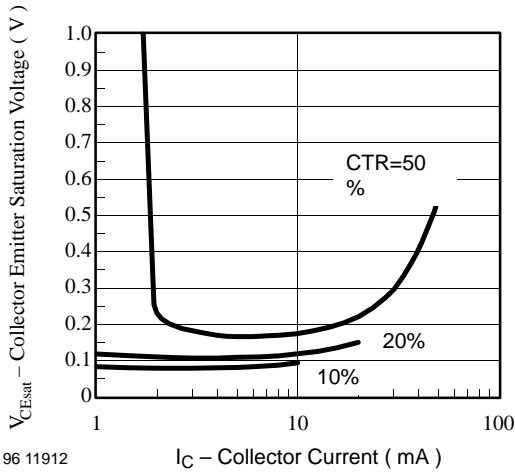
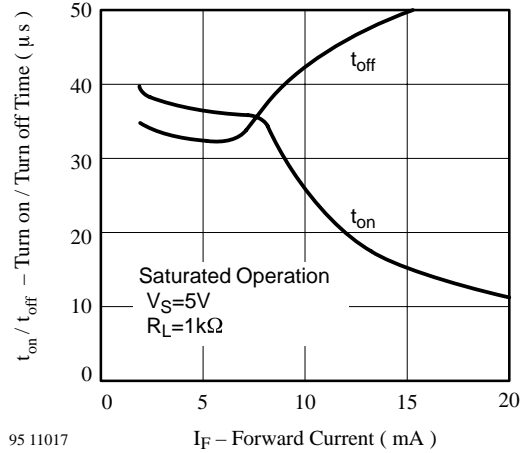

Figure 9. Collector Current vs. Collector Emitter Voltage



96 11912  $I_C$  – Collector Current ( mA )

Figure 10. Collector Emitter Saturation Voltage vs. Collector Current



95 11017  $I_F$  – Forward Current ( mA )

Figure 12. Turn on / off Time vs. Forward Current

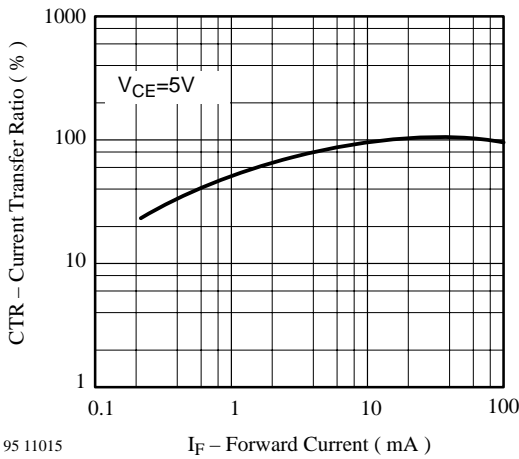

95 11015  $I_F$  – Forward Current ( mA )

Figure 11. Current Transfer Ratio vs. Forward Current

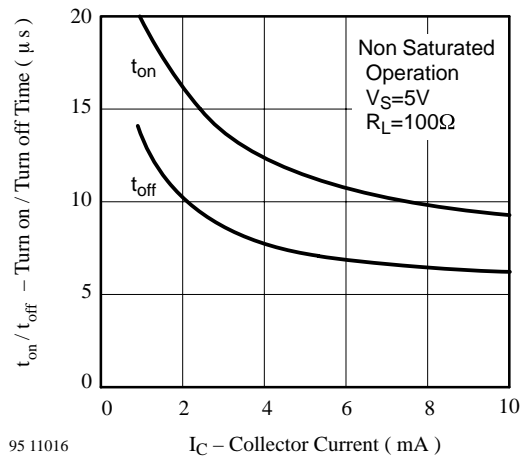

95 11016  $I_C$  – Collector Current ( mA )

Figure 13. Turn on / off Time vs. Collector Current

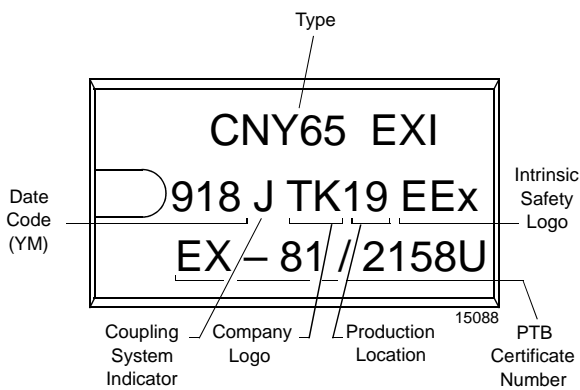
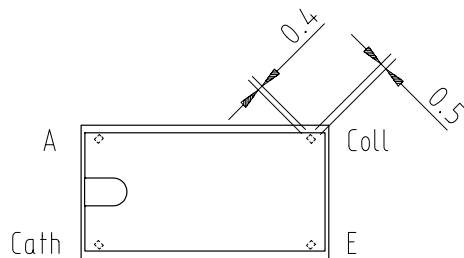
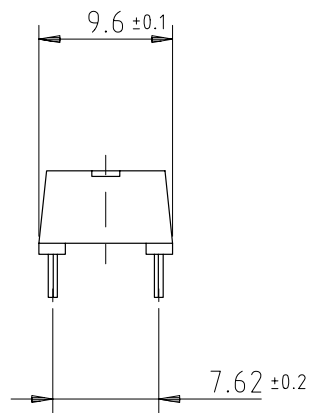
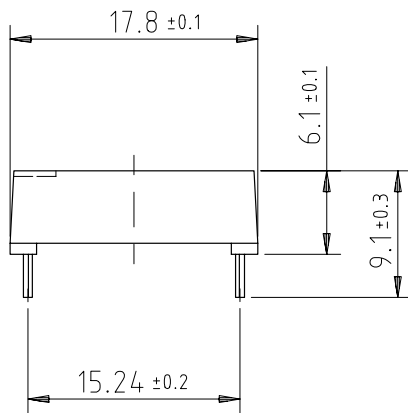

Figure 14. Marking example

## Dimensions of CNY65Exi in mm



weight: ca. 1.40 g  
 creepage distance:  $\geq 14$  mm  
 air path:  $\geq 14$  mm

after mounting on PC board

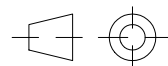

technical drawings  
 according to DIN  
 specifications

14763



## Стандарт Электрон Связь

Мы молодая и активно развивающаяся компания в области поставок электронных компонентов. Мы поставляем электронные компоненты отечественного и импортного производства напрямую от производителей и с крупнейших складов мира.

Благодаря сотрудничеству с мировыми поставщиками мы осуществляем комплексные и плановые поставки широчайшего спектра электронных компонентов.

Собственная эффективная логистика и склад в обеспечивает надежную поставку продукции в точно указанные сроки по всей России.

Мы осуществляем техническую поддержку нашим клиентам и предпродажную проверку качества продукции. На все поставляемые продукты мы предоставляем гарантию .

Осуществляем поставки продукции под контролем ВП МО РФ на предприятия военно-промышленного комплекса России , а также работаем в рамках 275 ФЗ с открытием отдельных счетов в уполномоченном банке. Система менеджмента качества компании соответствует требованиям ГОСТ ISO 9001.

Минимальные сроки поставки, гибкие цены, неограниченный ассортимент и индивидуальный подход к клиентам являются основой для выстраивания долгосрочного и эффективного сотрудничества с предприятиями радиоэлектронной промышленности, предприятиями ВПК и научно-исследовательскими институтами России.

С нами вы становитесь еще успешнее!

### Наши контакты:

**Телефон:** +7 812 627 14 35

**Электронная почта:** [sales@st-electron.ru](mailto:sales@st-electron.ru)

**Адрес:** 198099, Санкт-Петербург,  
Промышленная ул, дом № 19, литера Н,  
помещение 100-Н Офис 331